

0311-70441-C-A-01-00-Service (0152-15MY-MP)

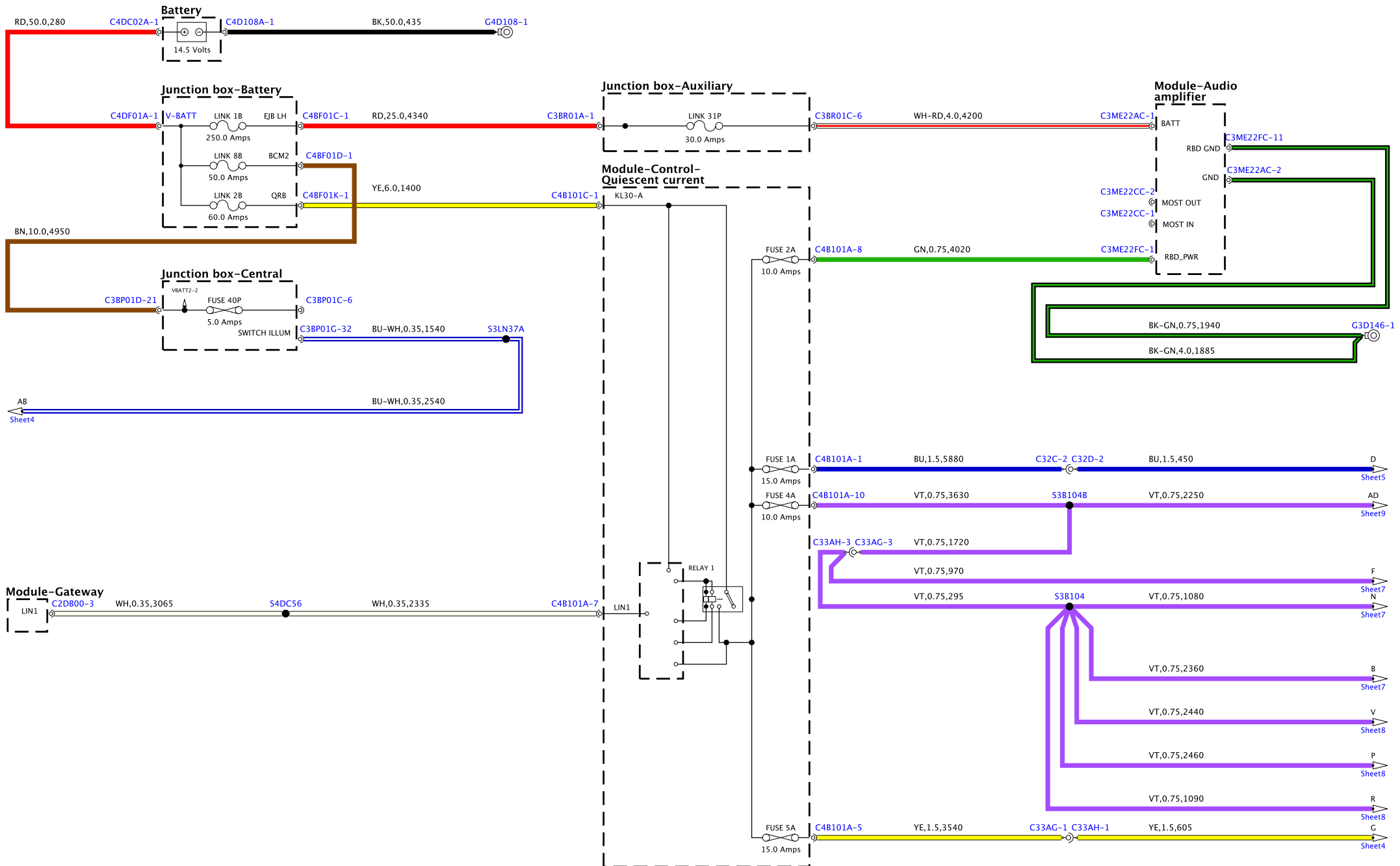

AB  
Sheet4

D  
Sheet5

AD  
Sheet9

F  
Sheet7

N  
Sheet7

B  
Sheet7

V  
Sheet8

P  
Sheet8

R  
Sheet8

G  
Sheet4

053-70441-C-A-02-09-Service (K152-150Y-MP3)

**Module-Audio amplifier**



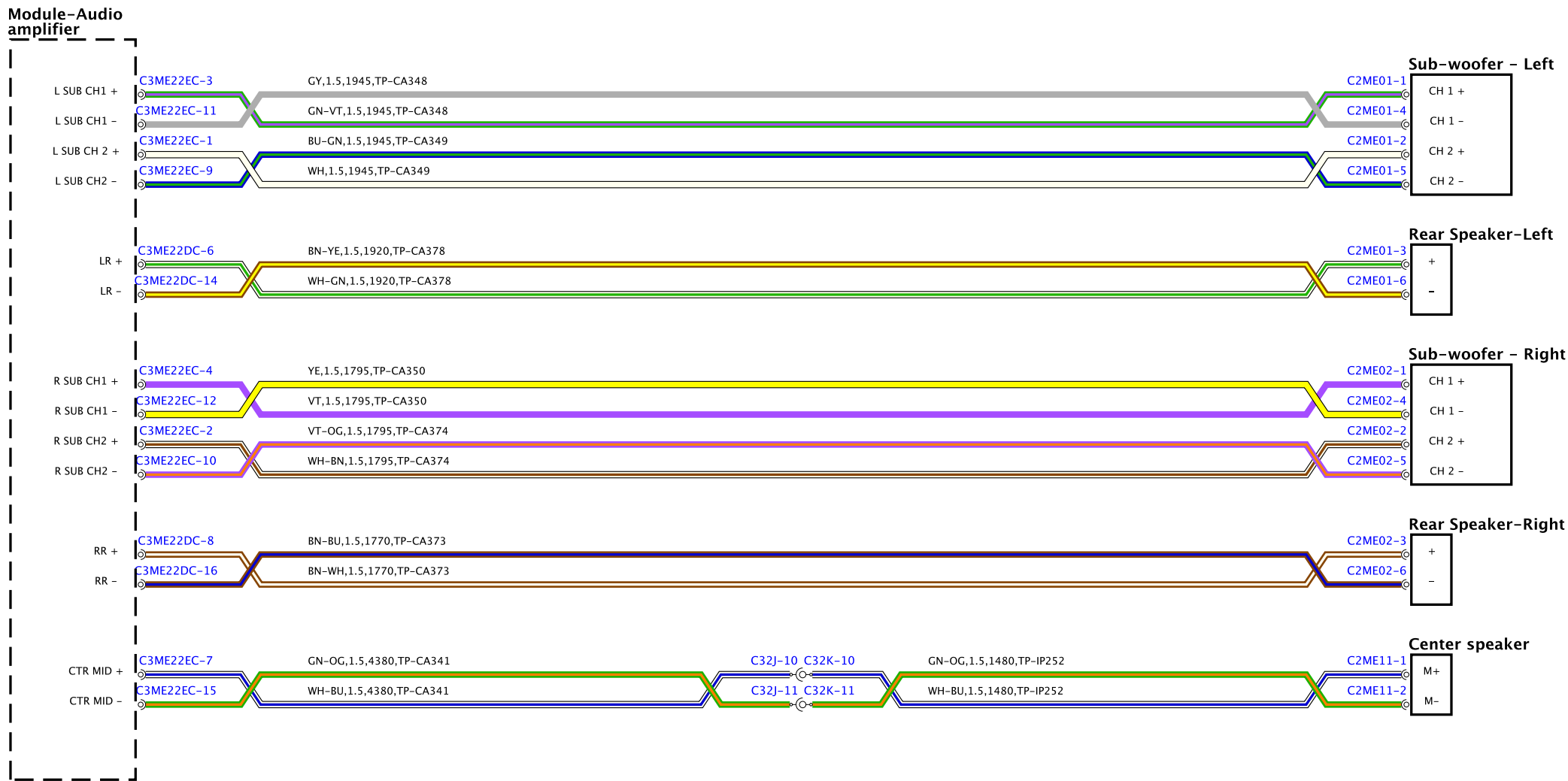

### Head Unit-Audio-System

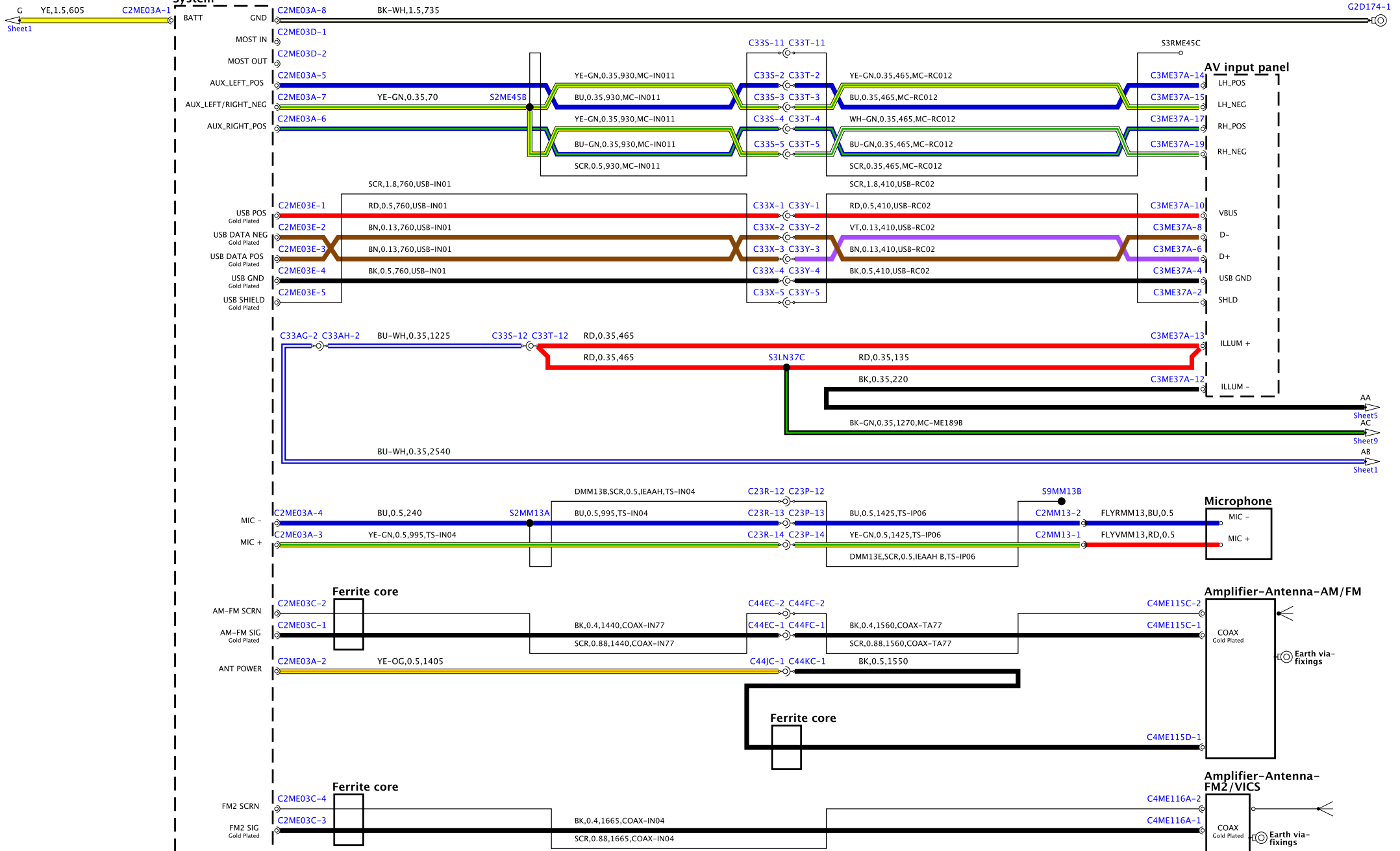

G  
Sheet1

G2D174-1

AA  
Sheet5  
AC  
Sheet9  
AB  
Sheet1

AV input panel

Microphone

Amplifier-Antenna-AM/FM

Amplifier-Antenna-FM2/VICS

Ferrite core

Ferrite core

Earth via-fixings

Earth via-fixings

D531-20441-C-A-05-09-Service (0152-15M-ME1)

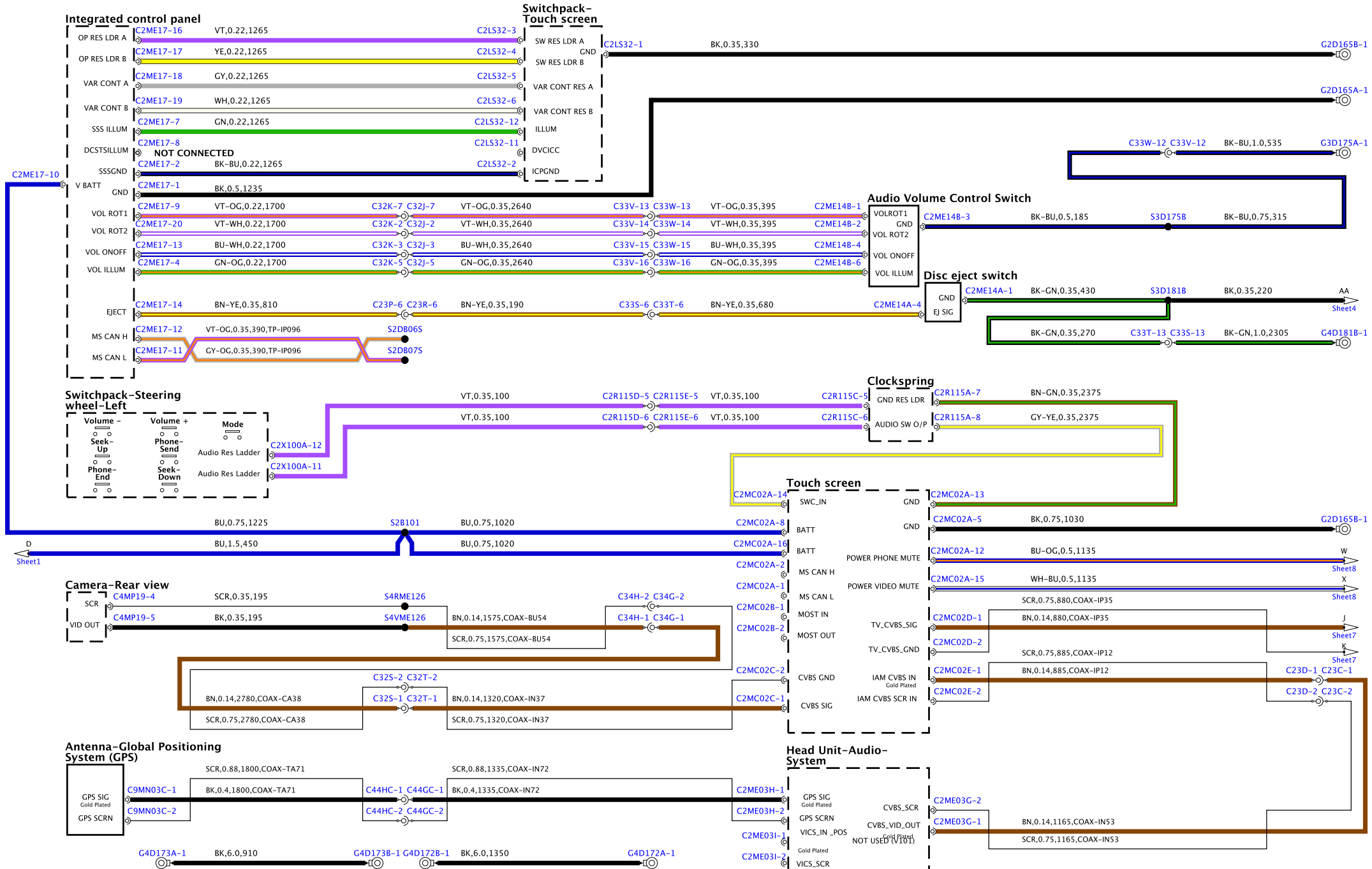

033-70441-C/A-00-00-Service (0332-13MY-MP1)

**Module-Telephone**

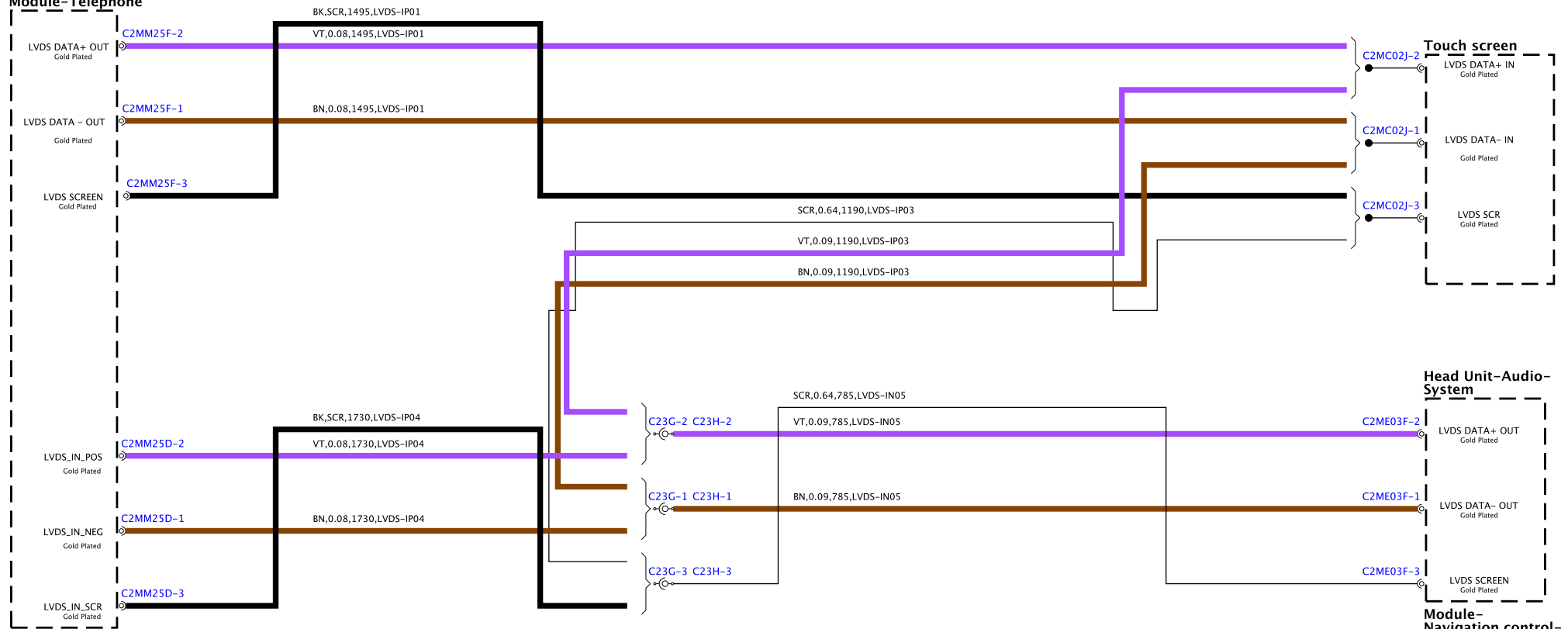

**Touch screen**

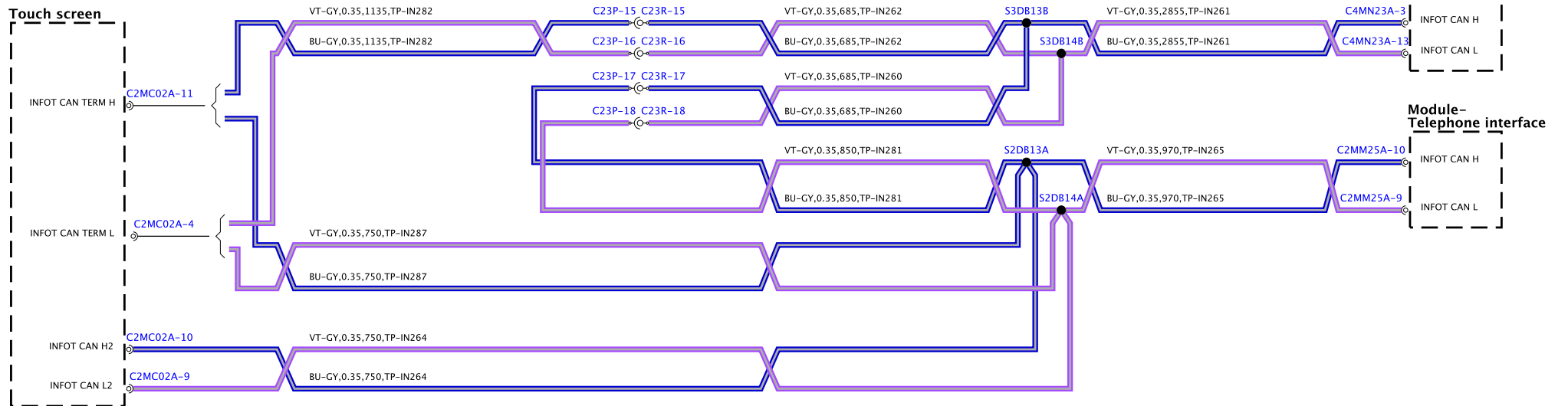

D511-70441-C-A-07-00-Service (0512-15M-IMP)

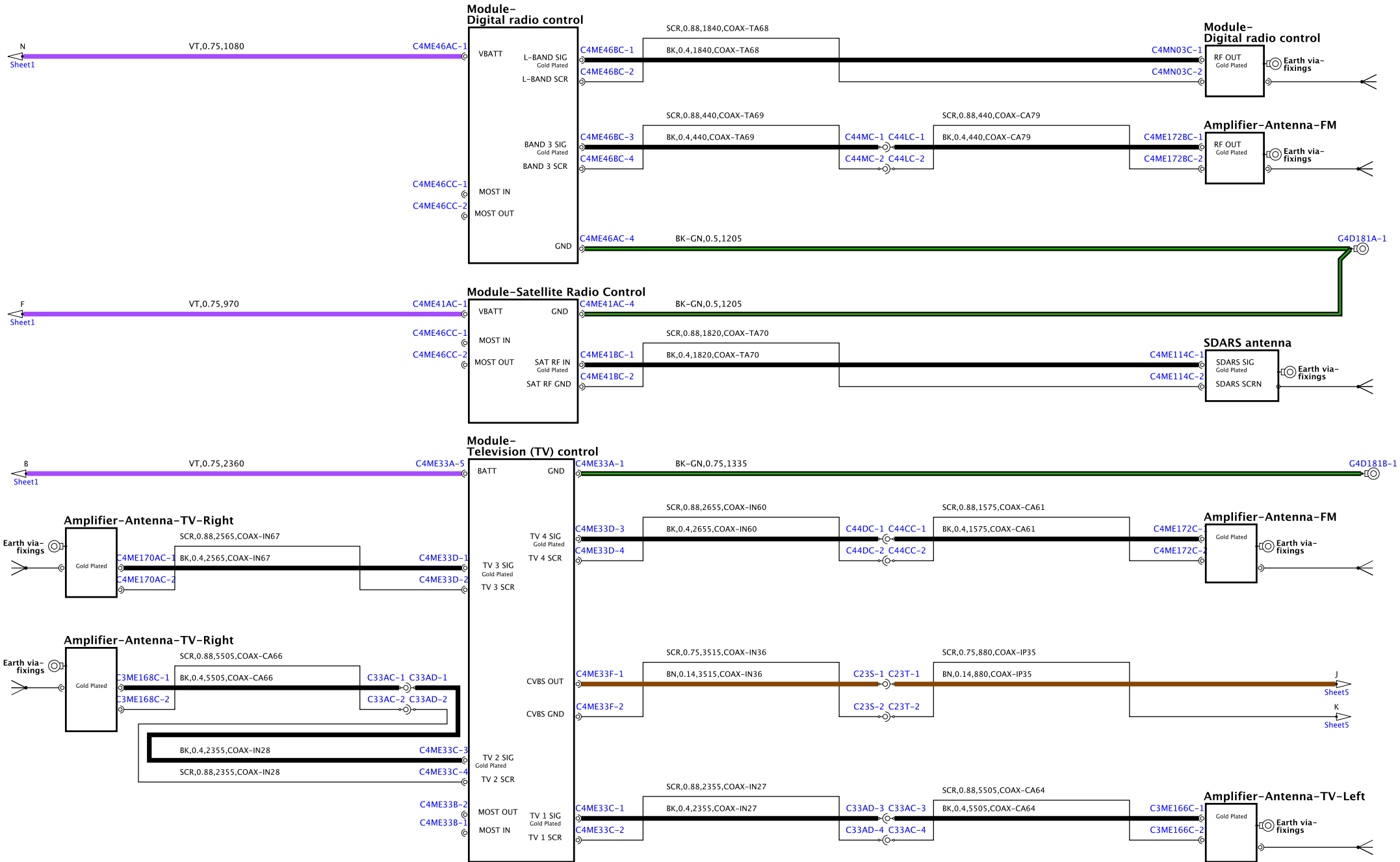

D51-70441-C-A-08-09-Service (0152-15M-MF)

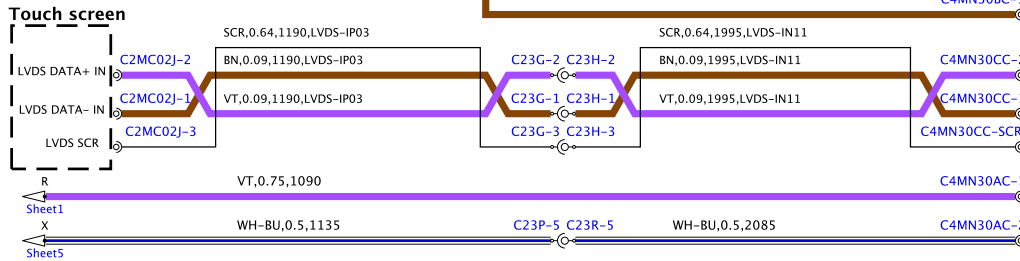
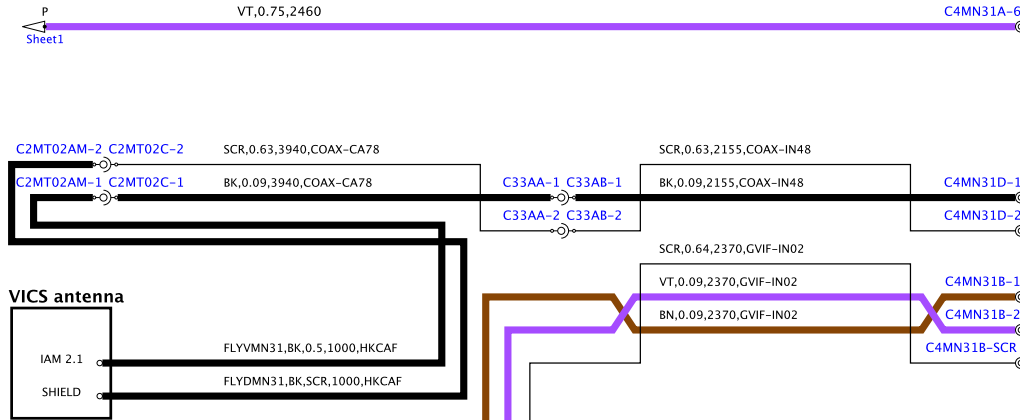
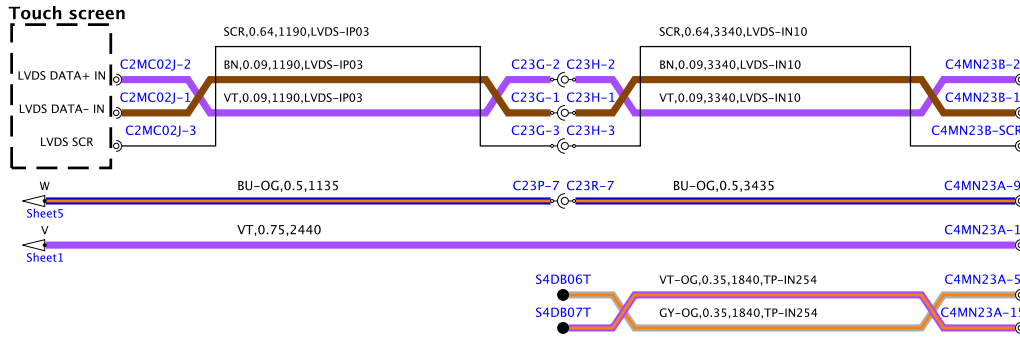

**Head Unit-Audio-System**

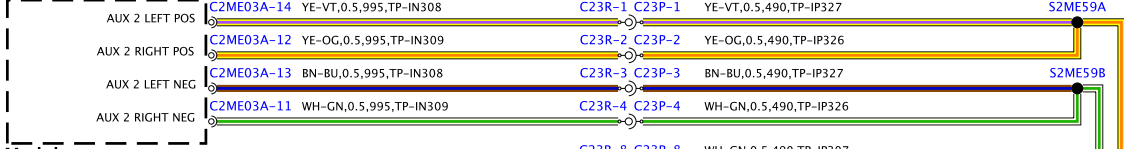

**Module-Navigation control-Asia**

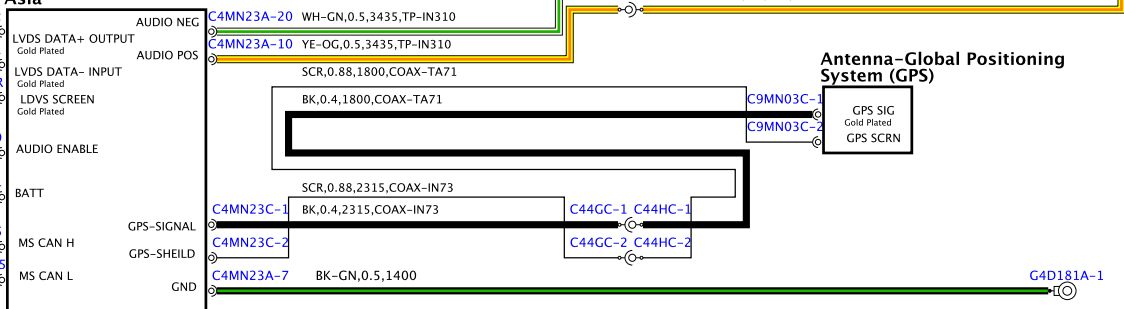

**Module-Navigation control-Japan**

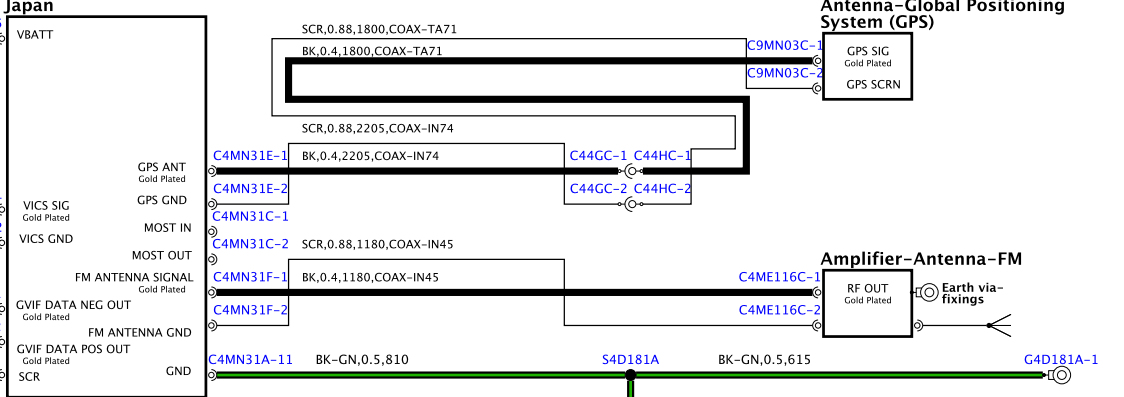

**Module-Video interface-Japan**

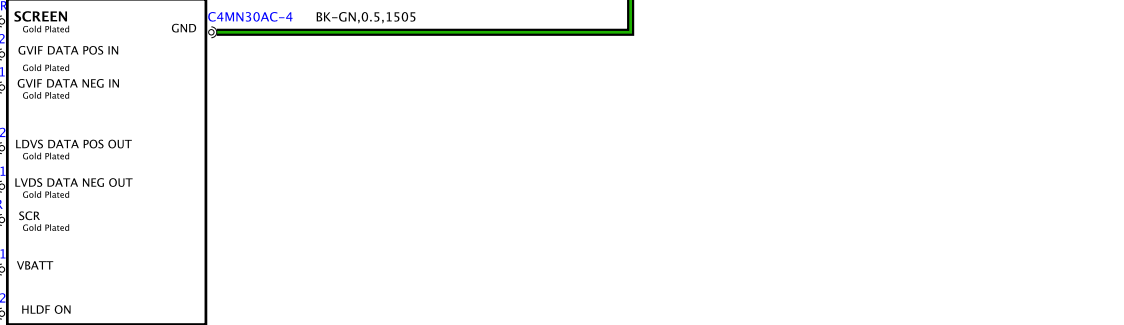



DS3-70441-C-A-09-09-Service (K152-15MY-MP)

