

PUBLISHED: 30-SEP-2019
2016.0 F-TYPE (X152), 303-03C

ENGINE COOLING - V8 S/C 5.0L PETROL [G1557291]

COMPONENT LOCATION

Rest Of World Vehicles

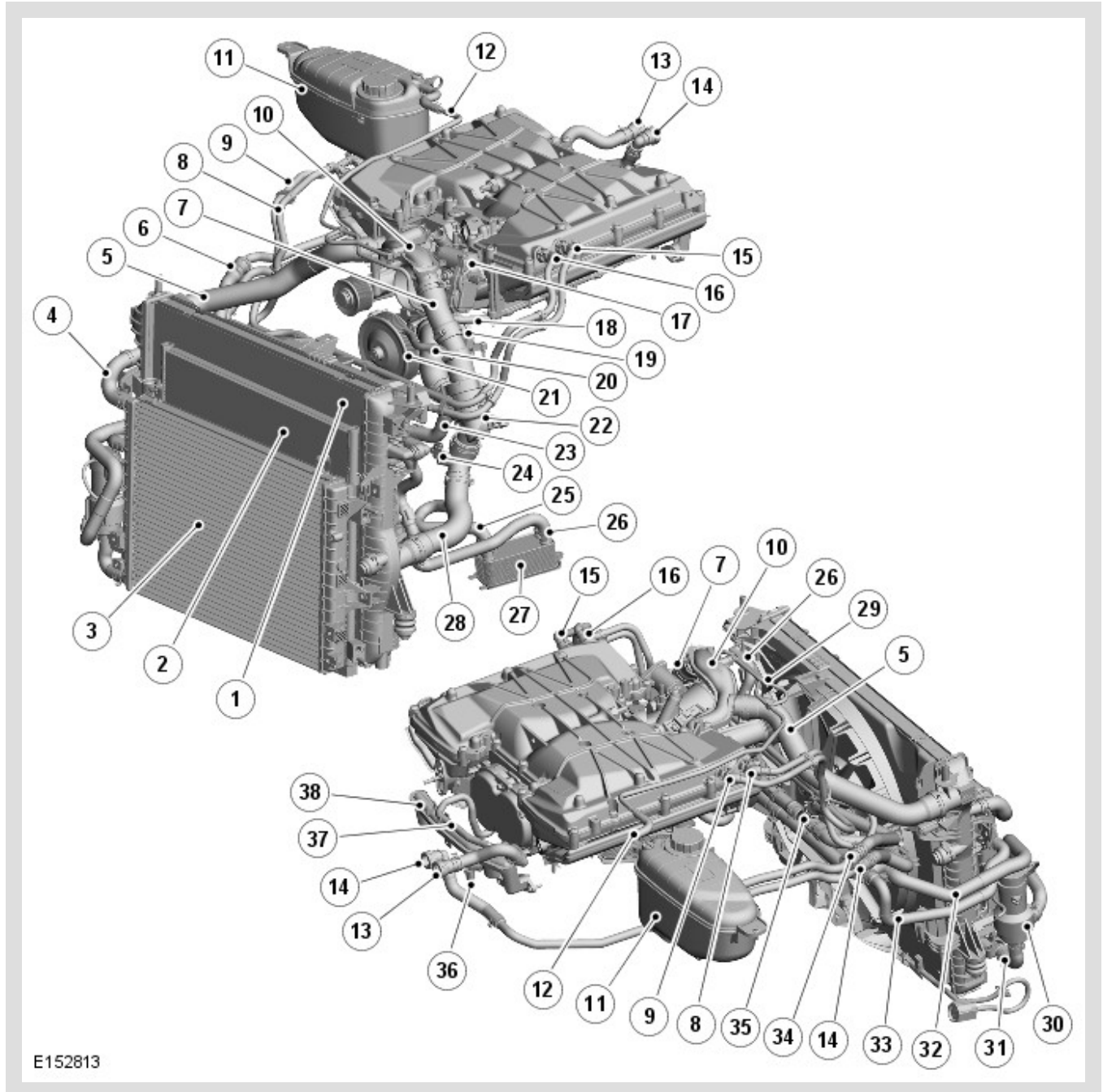

ITEM	DESCRIPTION
1	Radiator
2	Air Conditioning Condenser (reference only)

ITEM	DESCRIPTION
3	Charge Air Radiator (reference only)
4	Hose - Charge Air Radiator to Radiator - Supply
5	Radiator Upper Hose
6	Engine Coolant Return Hose
7	Hose - Thermostat Housing to Water Supply Tube
8	Hose - Supercharger to Charge Air Radiator - Return
9	Hose - Charge Air Radiator to Supercharger - Supply
10	Water Supply Tube
11	Coolant Expansion Tank
12	Air Bleed Hose Connection to Coolant Expansion Tank
13	Hose - Heater Core Supply
14	Hose - Heater Core Return
15	Hose - Charge Air Radiator to Supercharger - Supply
16	Hose - Supercharger to Charge Air Radiator - Return
17	Throttle Body
18	Hose - Throttle Body Heater Return
19	Water Outlet Tube
20	Hose - Throttle Body Heater Supply
21	Coolant Pump
22	Thermostat Housing
23	Hose Coolant Return
24	Engine Coolant Temperature (ECT) Sensor 2
25	Hose - Automatic Transmission Fluid (ATF) Cooler Outlet
26	Hose - Automatic Transmission Fluid (ATF) Cooler Inlet
27	Automatic Transmission Fluid (ATF) Cooler
28	Radiator - Lower Hose
29	Hose - Air Bleed
30	Charge Air Coolant Pump
31	Hose - Charge Air Radiator Inlet
32	Hose - Charge Air Cooler to Supercharger - Supply

ITEM	DESCRIPTION
33	Hose - Charge Air Radiator to Radiator - Return
34	Hose - Heater Core Return
35	Coolant Return 'Y' Connector
36	Engine Coolant Temperature (ECT) Sensor 1
37	Hose - Throttle Body Heater Return
38	Heater Supply Manifold

Hot Climate Markets

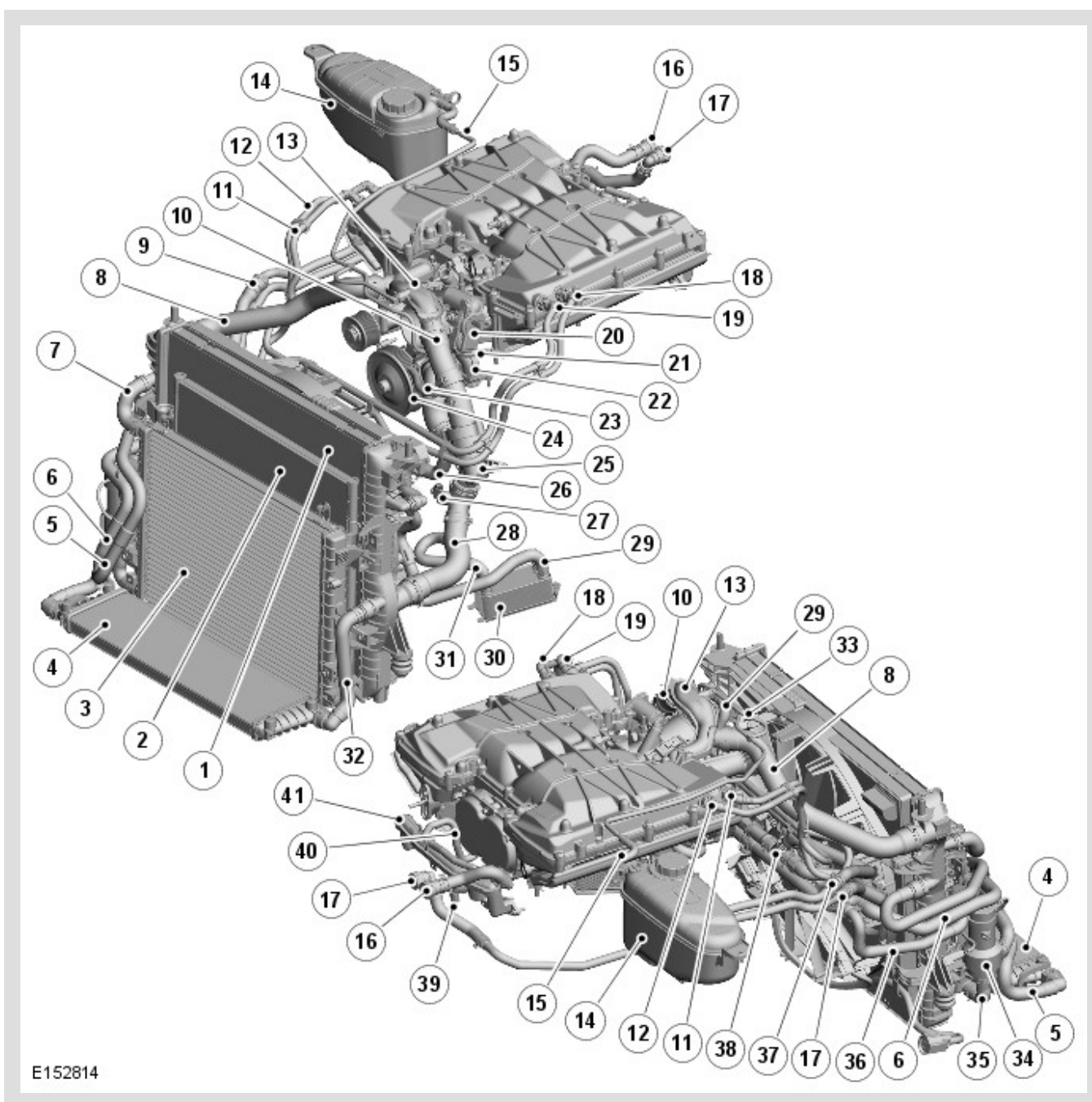

ITEM	DESCRIPTION
1	Radiator
2	Air Conditioning Condenser (reference only)
3	Charge Air Radiator (reference only)
4	Auxiliary Radiator
5	Auxiliary Radiator Inlet Hose
6	Hose - Charge Air Radiator to Supercharger - Supply
7	Hose - Charge Air Radiator to Radiator - Supply
8	Radiator Upper Hose
9	Engine Coolant Return Hose
10	Hose - Thermostat Housing to Water Supply Tube
11	Hose - Supercharger to Charge Air Radiator - Return
12	Hose - Charge Air Radiator to Supercharger - Supply
13	Water Supply Tube
14	Coolant Expansion Tank
15	Hose - Air Bleed Connection to Coolant Expansion Tank
16	Hose - Heater Core Supply
17	Hose - Heater Core Return
18	Hose - Charge Air Radiator to Supercharger - Supply
19	Hose - Supercharger to Charge Air Radiator - Return
20	Throttle Body
21	Hose - Throttle Body Heater Return
22	Water Outlet Tube
23	Hose - Throttle Body Heater Supply
24	Coolant Pump
25	Thermostat Housing
26	Hose - Coolant Return
27	Engine Coolant Temperature (ECT) Sensor 2
28	Radiator - Lower Hose
29	Hose - Automatic Transmission Fluid (ATF) Cooler Inlet
30	Automatic Transmission Fluid (ATF) Cooler

ITEM	DESCRIPTION
31	Hose - Automatic Transmission Fluid (ATF) Cooler Outlet
32	Hose - Auxiliary Radiator Outlet
33	Hose - Air Bleed
34	Charge Air Coolant Pump
35	Hose - Charge Air Radiator Inlet
36	Hose - Charge Air Radiator to Radiator - Return
37	Hose - Heater Core Return
38	Coolant Return 'Y' Connector
39	Engine Coolant Temperature (ECT) Sensor 1
40	Hose - Throttle Body Heater Return
41	Heater Supply Manifold

Engine Cylinder Block Heater

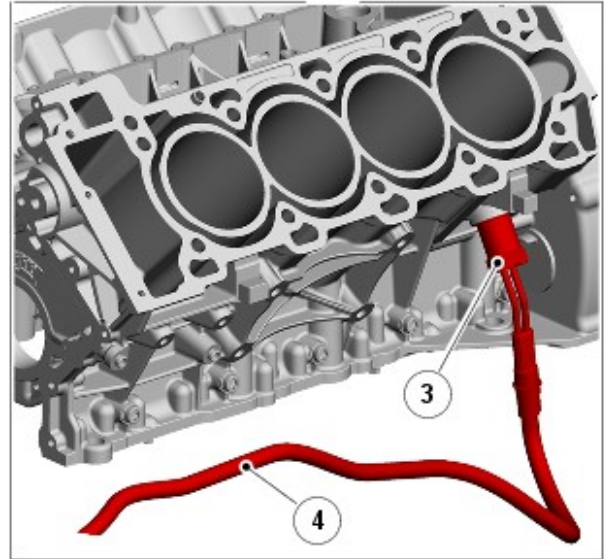
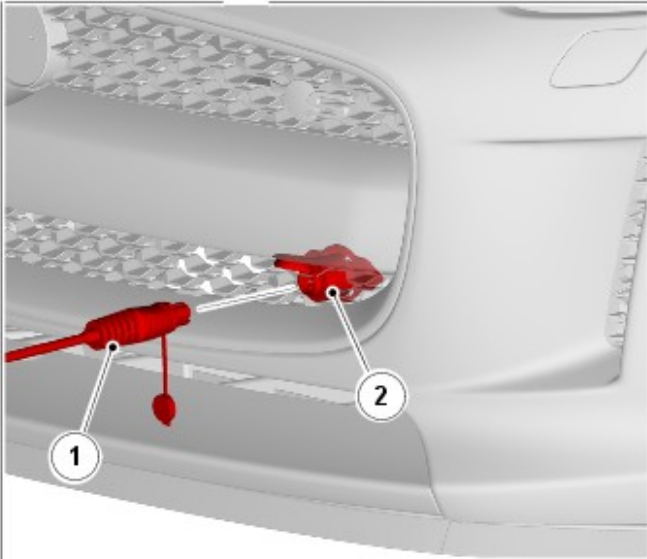
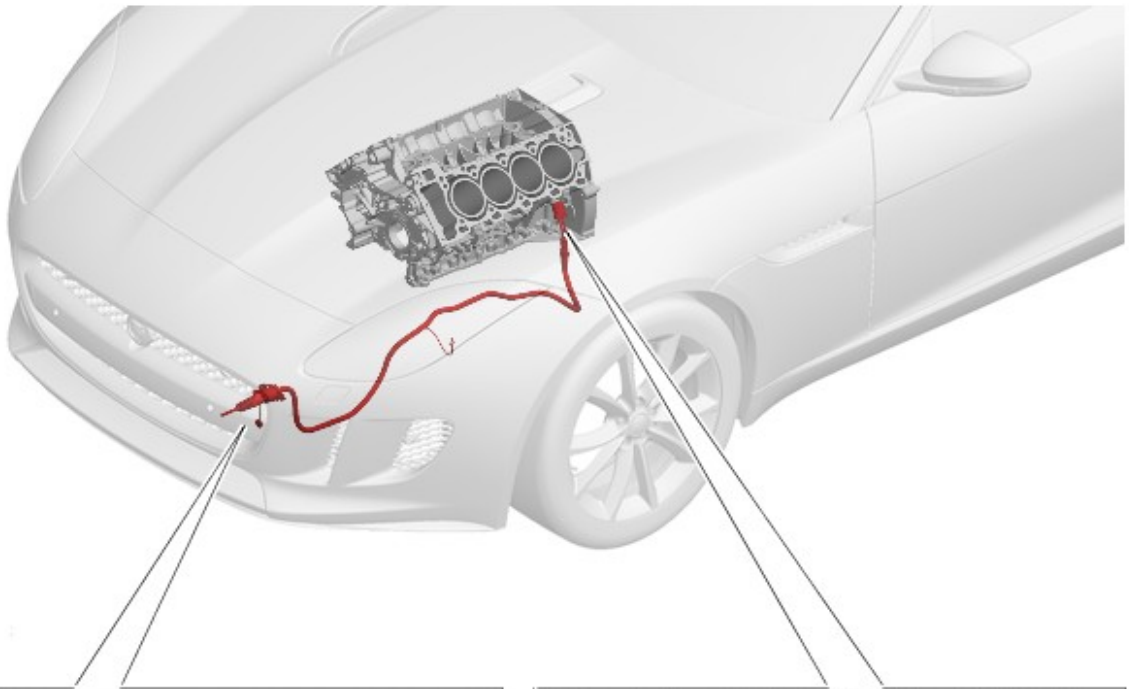

E152815

ITEM	DESCRIPTION
1	Power Supply Connector
2	Vehicle Connector
3	Block Heater
4	Harness

The engine cooling system maintains the engine within an optimum temperature range under changing ambient and engine operating conditions. The system is a pressurized expansion tank system with continuous bleeds to separate air from the coolant and prevent the formation of air locks. The engine cooling system also provides:

- Heating for:
 - The Passenger Compartment
 - The Throttle Body
- Cooling for:
 - The Engine Oil Cooler
 - The Engine
 - The Automatic Transmission Fluid (ATF) Cooler

The primary components of the engine cooling system are the:

- Coolant Pump
- Thermostat
- Radiator
- Electric Cooling Fan
- Coolant Expansion Tank
- Engine Oil Cooler
- Outlet Tube and Heater Manifold
- Connecting Hoses and Pipes

An auxiliary cooler is installed on vehicles in some hot climate markets. The auxiliary cooler is located in front of the radiator.

In vehicle markets subject to very cold climatic conditions, a cylinder block heater can be installed.

COMPONENT DESCRIPTION

COOLANT PUMP

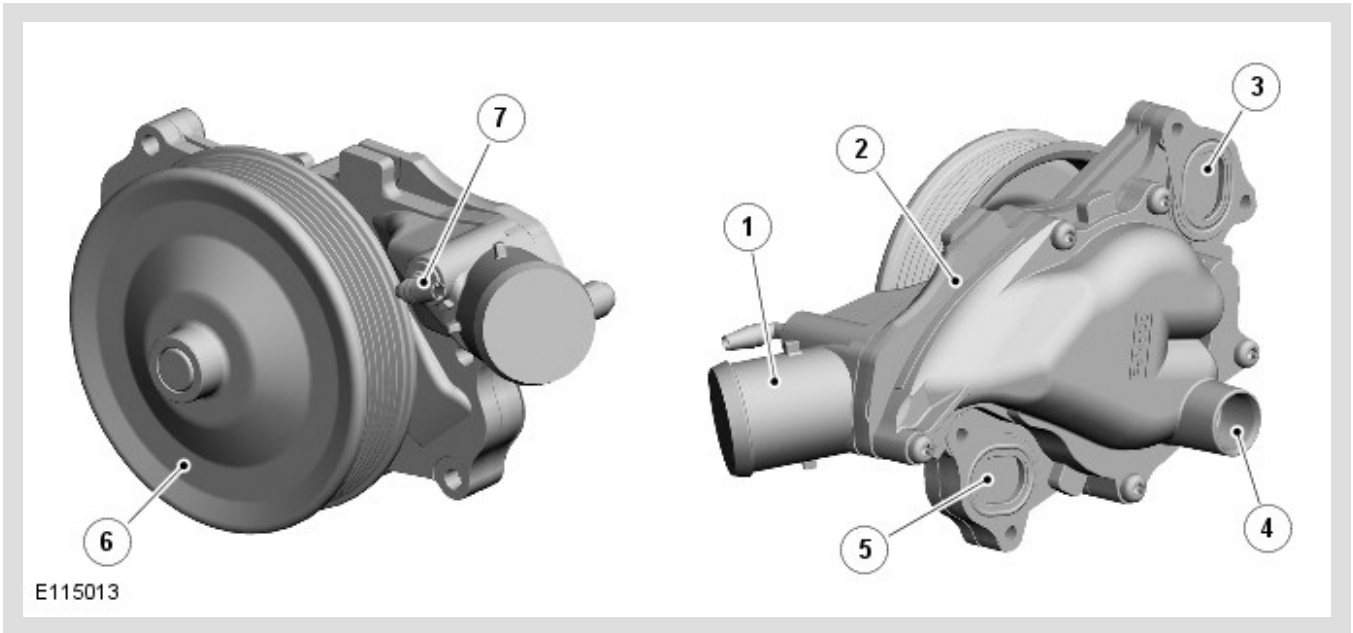

ITEM	DESCRIPTION
1	Inlet Connection
2	Pump Body
3	Outlet Flange to Right Cylinder Head
4	Outlet to Engine Oil Cooler
5	Outlet Flange to Left Cylinder Head
6	Pulley
7	Bleed Pipe Connection (including check valve)

The body of the coolant pump contains an impeller attached to a shaft supported in a bearing assembly. The impeller is driven by a pulley, pressed on to the front of the shaft, which is driven by the accessory drive belt.

Two coolant outlet flanges attach the coolant pump to the front of the cylinder heads. A bleed connector is installed in the front of the coolant pump, adjacent to the coolant inlet connection from the thermostat. A check valve is incorporated into the bleed connection.

THERMOSTAT HOUSING

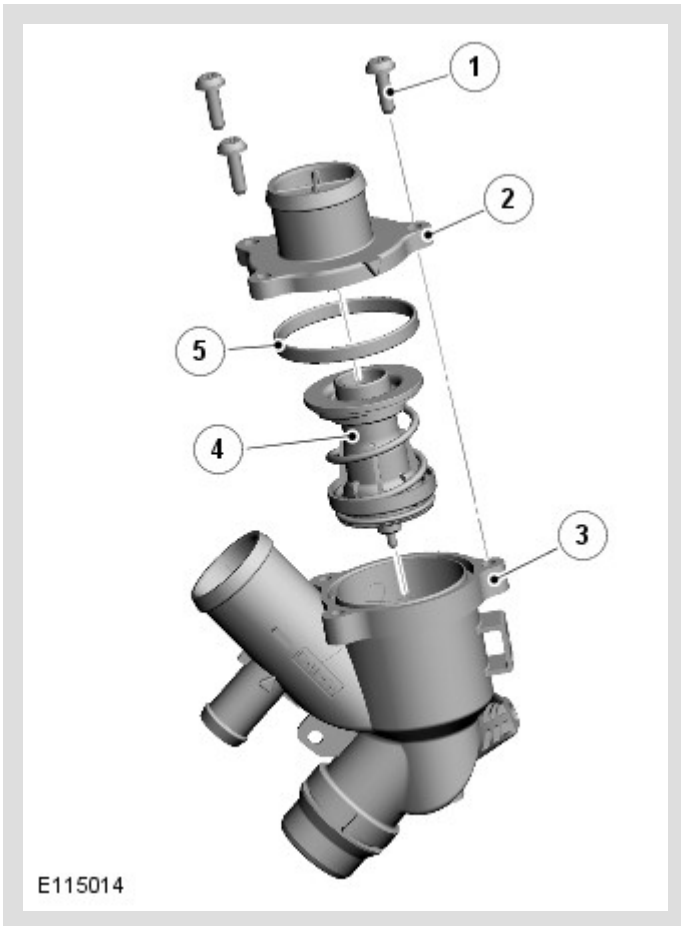

ITEM	DESCRIPTION
1	Screw (3 Off)
2	Upper Body
3	Lower Body
4	Thermostat
5	Seal

The thermostat is a multi-stage device located in the coolant pump inlet to provide fast response and control of the engine outlet temperature.

The thermostat housing has 4 connections. The lower connection receives a quick fit connector which receives coolant from the radiator lower hose and the automatic transmission fluid cooler. The larger upper connection is connected through a hose, water supply tube and water outlet to the cylinder block. The flow from this connection is governed by the thermostat. A connection at the side provides flow to the coolant pump and a smaller connection from this receives coolant return from the heater core and the coolant expansion tank.

The thermostat allows rapid engine warm-up by preventing coolant flow through the radiator and by limiting coolant flow through the cylinder block when the engine is cold. During warm-up and at engines speeds above approximately

3,500 Revolutions Per Minute (RPM), a by-pass valve opens to control the coolant flow and pressure, to protect the engine components. When the thermostat opening reaches 6 mm (0.24 in.), the by-pass flow is shut-off. When the thermostat opening exceeds 6 mm (0.24 in.), the radiator coolant flow is further controlled up to the point where the thermostat is fully open. At this point maximum radiator coolant flow is achieved to provide maximum cooling.

The thermostat begins to open at 88 - 90 °C (190 - 194 °F) and is fully open at 102 °C (216 °F).

RADIATOR

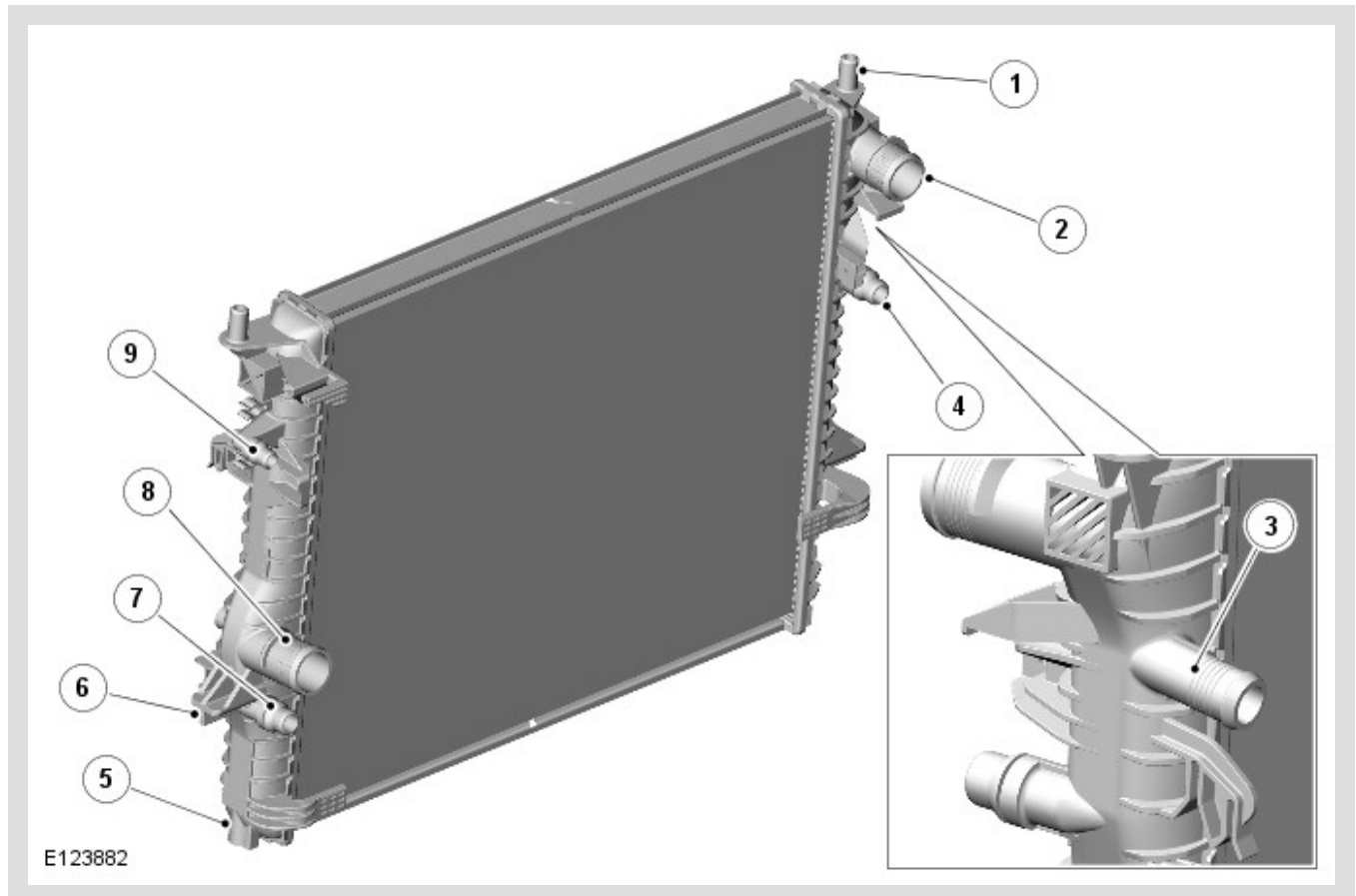

ITEM	DESCRIPTION
1	Locating Spigot (2 Off)
2	Upper Hose Connection
3	Supercharger Cooling System Connection
4	Auxiliary Radiator Inlet Hose Connection
5	Drain Plug
6	Support (2 Off)
7	Auxiliary Radiator Outlet Hose Connection
8	Lower Hose Connection
9	Automatic Transmission Fluid (ATF) Cooler Outlet Hose Connection

The radiator is a cross flow type with an aluminum core and plastic end tanks. The radiator is part of the cooling module and is attached to the vehicle by locating spigots and supports integrated into the end tanks. The supports are installed in rubber bushes located in mounting brackets on the front subframe. The locating spigots are installed in rubber bushes located in mounting brackets on the front cross member.

The two end tanks incorporate connections for the upper and lower hoses, the coolant supply hose of the transmission fluid cooler and the supply and return hoses of the auxiliary radiator(s). A drain plug is installed in the bottom of the left end tank.

The upper section of the radiator is separated to supply only the automatic transmission fluid (ATF) cooler. The left end tank of the radiator is partitioned and coolant from this part of the radiator is directed to the ATF cooler.

AUXILIARY RADIATOR - IF EQUIPPED

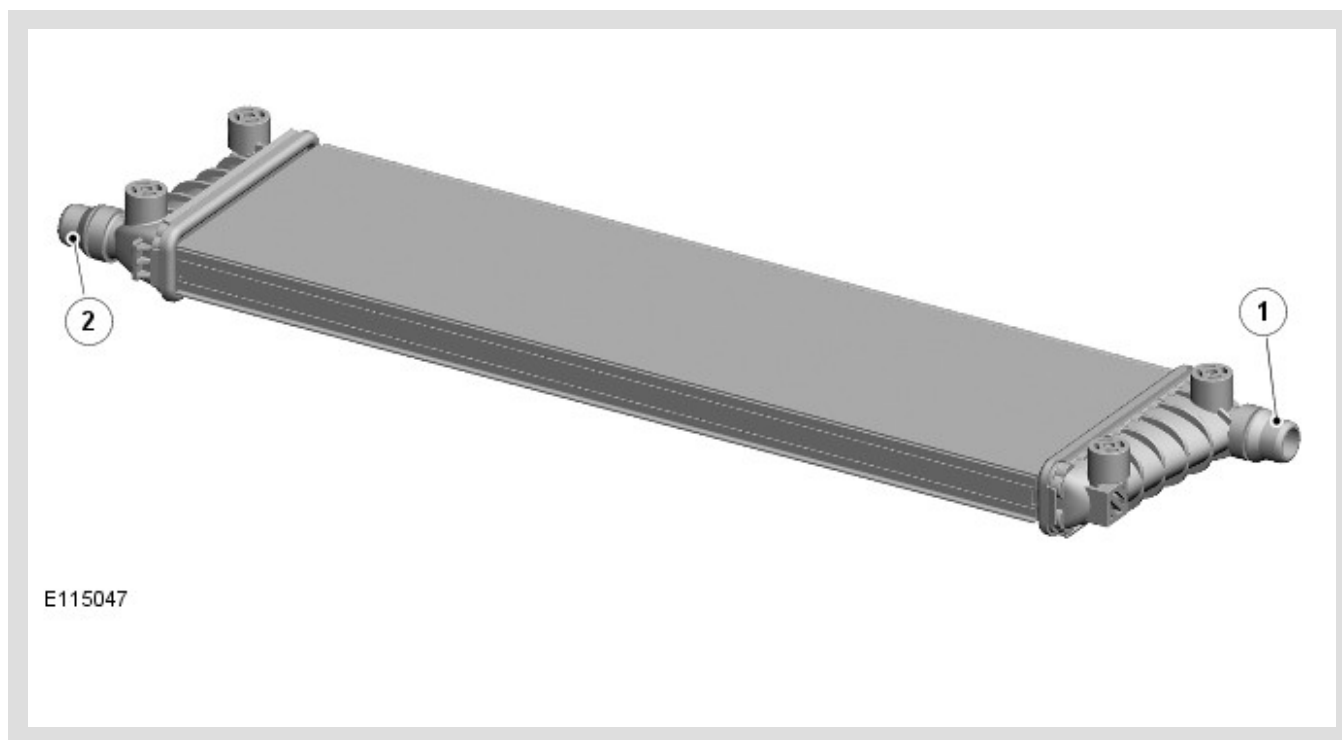

ITEM	DESCRIPTION
1	Supply Hose Connection
2	Return Hose Connection

The auxiliary radiator is connected in parallel with the (main) radiator to increase the engine cooling capacity on hot climate market vehicles.

The auxiliary radiator is mounted horizontally in an air deflector attached to the front of the charge air radiator. The two end tanks of the auxiliary radiator incorporate connections for the supply and return hoses that connect it to the main radiator.

The auxiliary radiator is attached to the air deflector with four flange head bolts. The air deflector is attached to the radiator.

ELECTRIC COOLING FAN

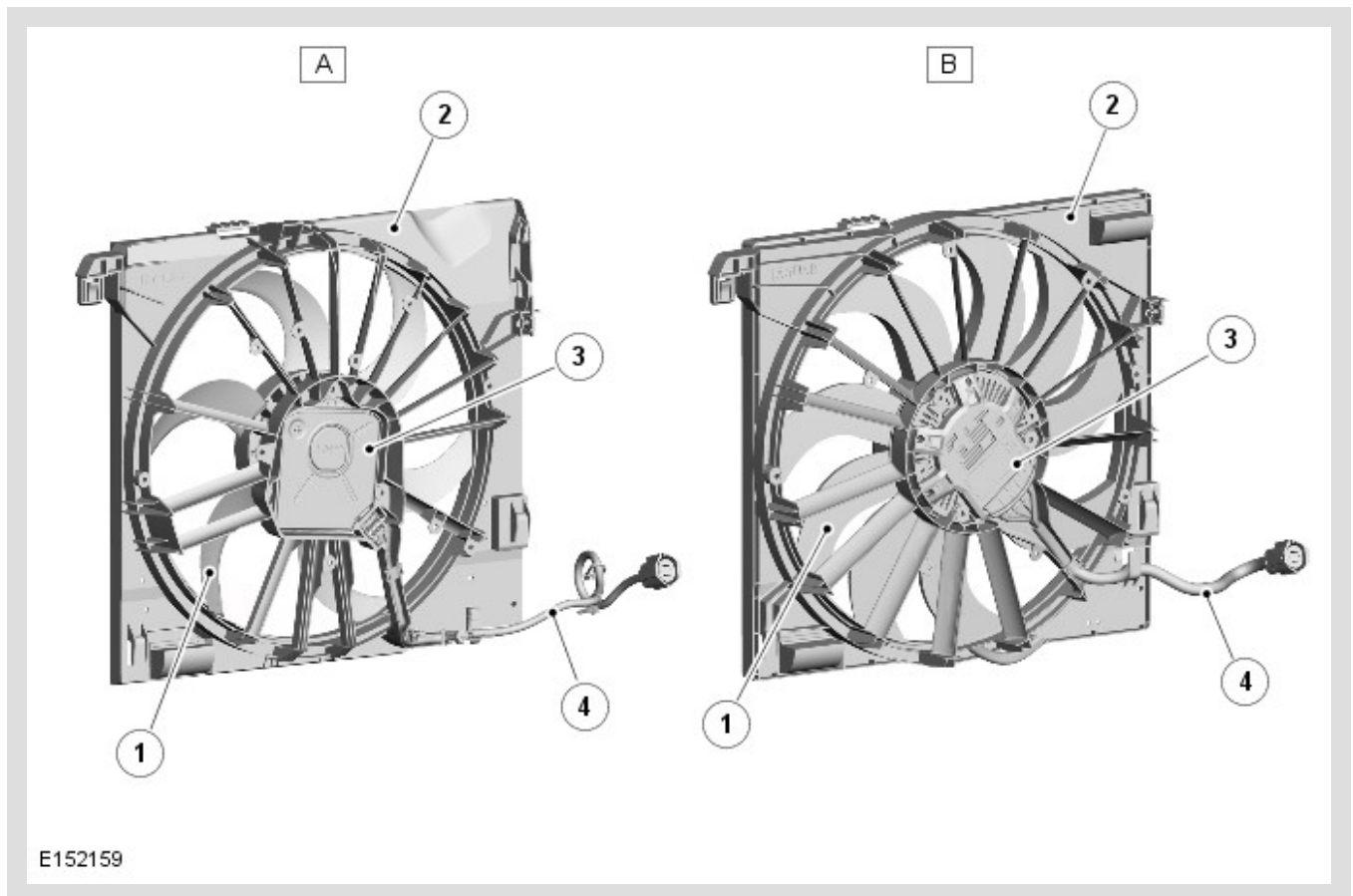

ITEM	DESCRIPTION
A	500W Rest Of World (ROW)
B	850W Hot Climate Markets
1	Fan
2	Shroud
3	Engine Cooling Fan Control Module
4	Harness

A variable speed electric cooling fan is installed in a shroud attached to the rear of the radiator.

Two variants of the cooling fan are available; ROW markets have a 500W cooling fan. Hot climate markets are equipped with an 850W cooling fan. The fan in these markets have more blades than the ROW fan and the shroud has an additional air vent in the top right of the shroud to allow additional air flow into the engine compartment.

The cooling fan is operated by the engine cooling fan control module which, is integrated into the electric motor. The control module is controlled by the engine control module (ECM) which outputs a pulse width modulation (PWM) signal to control the fan operating speed. An electrical connector at the right side of the shroud provides the interface between the electric cooling fan harness and the vehicle wiring.

ENGINE COOLANT EXPANSION TANK

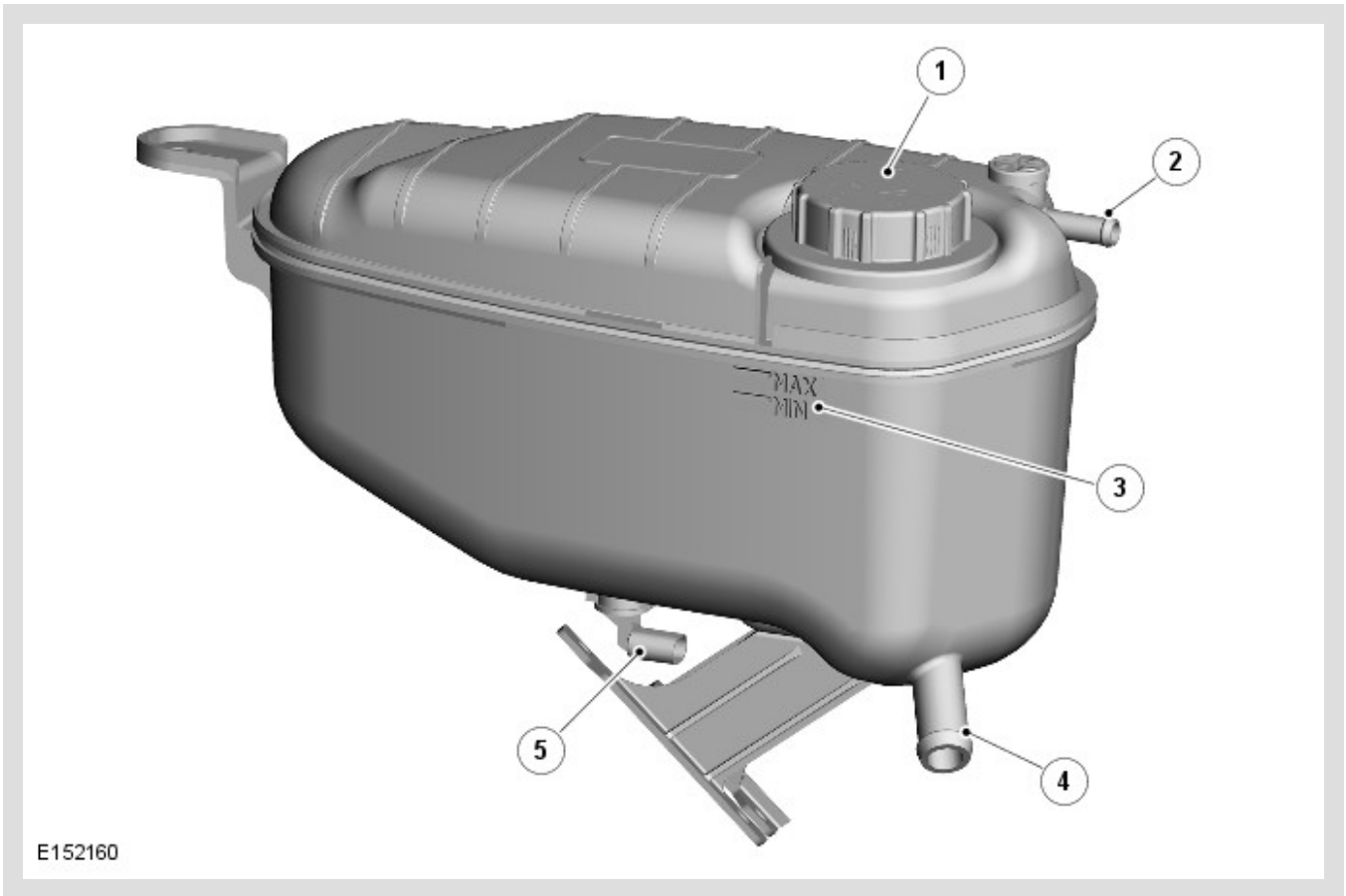

ITEM	DESCRIPTION
1	Filler cap
2	Air bleed hose connection
3	Minimum and maximum level markings
4	Expansion hose connection
5	Engine coolant level sensor

The engine coolant expansion tank is installed in the rear right of the engine compartment.

A filler cap and level sensor are incorporated into the expansion tank. A 'MAX' and 'MIN' cold fill level markings are molded into the exterior of the tank below the filler cap.

The coolant expansion tank provides the following functions:

- The service fill.
- Engine coolant expansion during warm up.
- Air separation during operation.
- System pressurization by the filler cap.

- Coolant level sensing.

The engine coolant expansion tank has an air space of approximately 0.5 liter (1.06 US pints), above the MAX level, to allow for coolant expansion.

The engine coolant level sensor locates in a sealed cavity at the bottom of the coolant expansion tank body. A float with an integral magnet is located inside the coolant expansion tank. The coolant level sensor contains a switch that reacts to the position of the magnetic float. The coolant level sensor is hardwired to the Body Control Module/Gateway Module (BCM/GWM).

The magnetic float is designed to float very close to the bottom of the tank, significantly below the MIN cold fill coolant level. The magnetic float in this position does not indicate float failure, for example sinking or sticking. The float has a travel distance of approximately 15 mm (0.59 in) from the bottom of the tank.

ENGINE COOLANT OUTLET TUBE AND HEATER MANIFOLD

Engine Coolant Outlet Tube

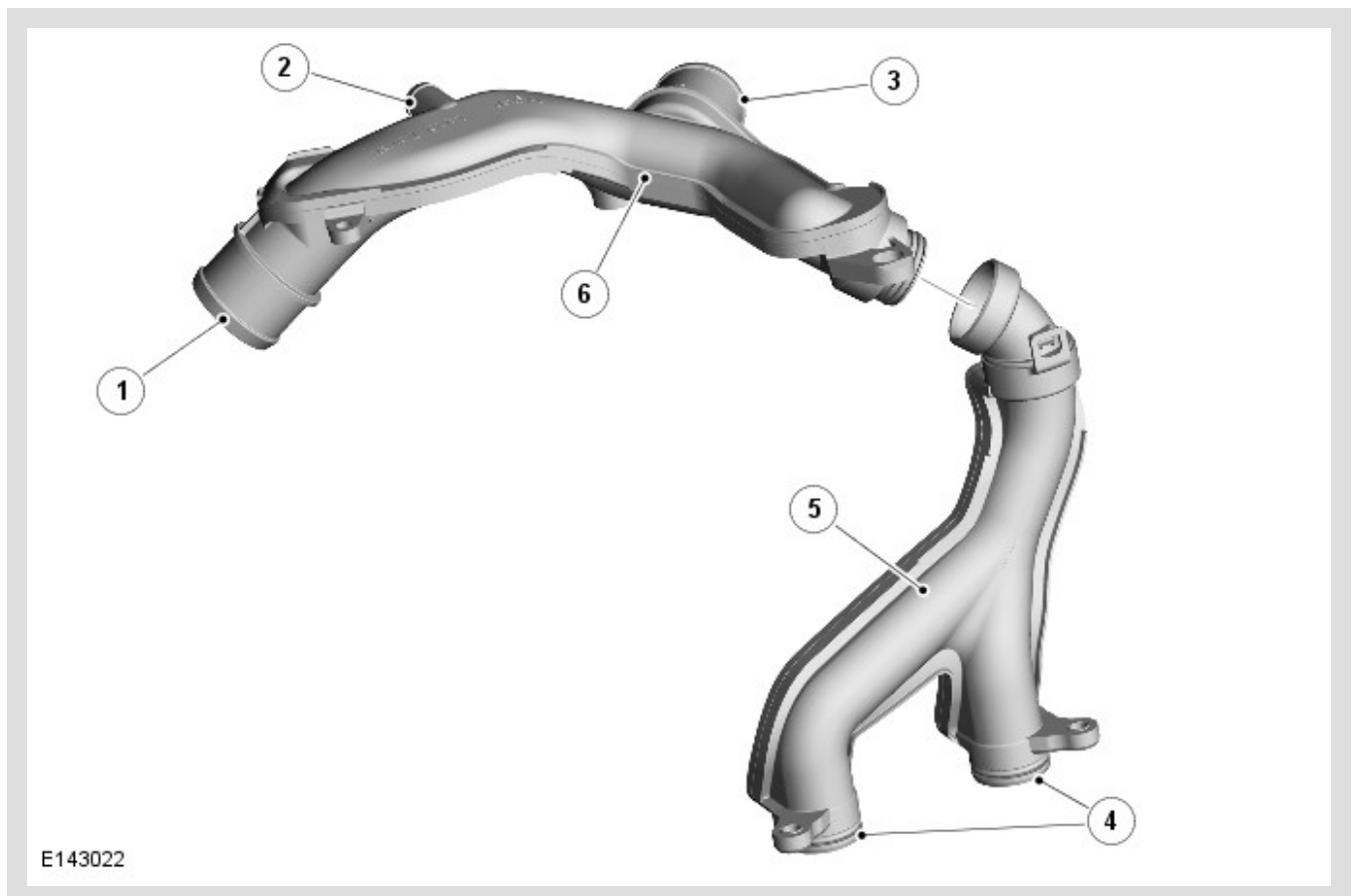

ITEM	DESCRIPTION
1	Thermostat Hose Connection
2	Air Bleed Hose Connection
3	Radiator Upper Hose Connection
4	Cylinder Block Connections

ITEM	DESCRIPTION
5	Water Outlet Tube
6	Water Supply Tube

Heater Manifold

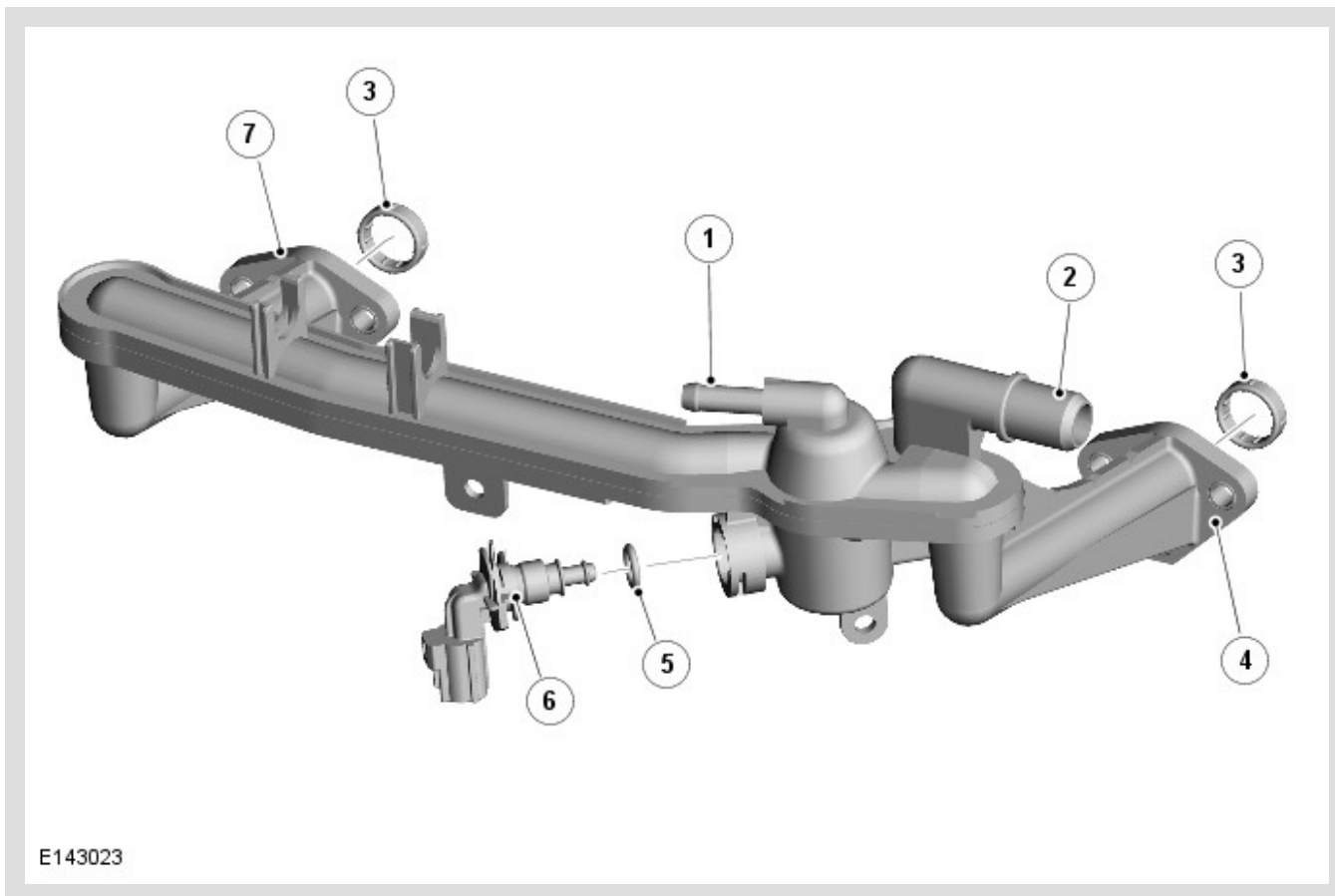

ITEM	DESCRIPTION
1	Throttle Body Heater Hose Connection
2	Heater Core Supply Hose Connection
3	Seal (2 Off)
4	Right Cylinder Head Connection
5	O-Ring Seal
6	Engine Coolant Temperature (ECT) Sensor 1
7	Left Cylinder Head Connection

The engine coolant outlet tube routes hot engine coolant from the engine to the radiator top hose when the thermostat is open.

The heater manifold is connected to the rear of each cylinder head. Hot coolant from the engine is routed through the manifold into the heater core.

ENGINE COOLANT

The engine coolant is formulated to last for ten years or 240,000 km (150,000 miles). The coolant is silicate free and must not be mixed with conventional engine coolant.

CYLINDER BLOCK HEATER



For vehicle markets subject to very cold climatic conditions, a cylinder block heater is installed in place of the cylinder block drain plug. The cylinder block heater is either a 110 V ac or 240 V ac electric heater element, depending on the market, which can be connected to a domestic power supply through a connector in the lower part of the radiator grille of the front bumper.

SYSTEM OPERATION

Engine Cooling Flow Operation – Rest Of World

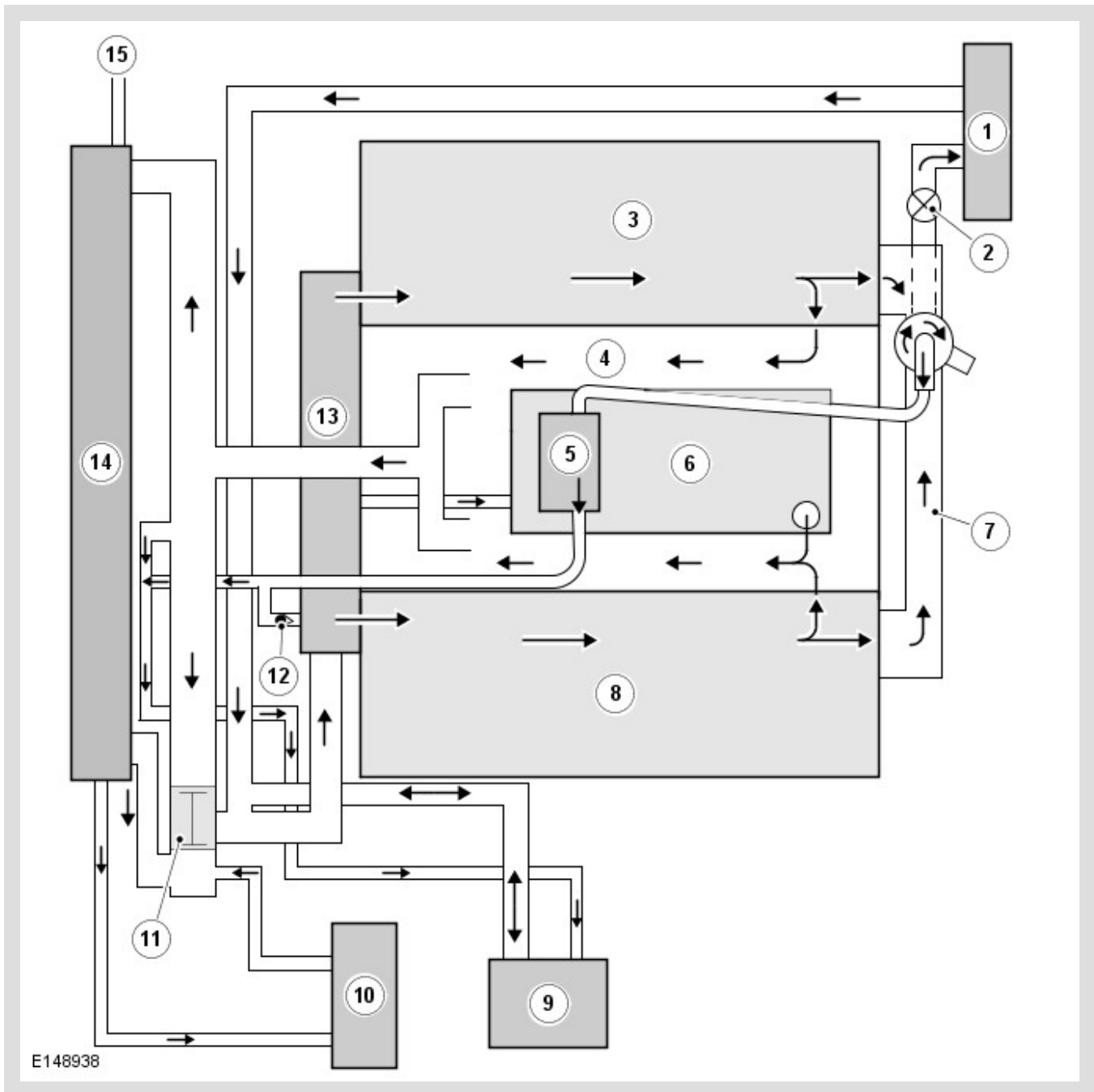

ITEM	DESCRIPTION
1	Heater Core
2	Air Bleed Screw
3	Right Cylinder Head
4	Cylinder Block
5	Throttle Housing
6	Engine Oil Cooler
7	Heater Manifold
8	Left Cylinder Head

ITEM	DESCRIPTION
9	Expansion Tank
10	Automatic Transmission Fluid (ATF) Cooler
11	Thermostat
12	Check Valve
13	Coolant Pump
14	Radiator
15	15 Connection with Supercharger Cooling System

Engine Cooling Flow Diagram - Hot Climate Markets

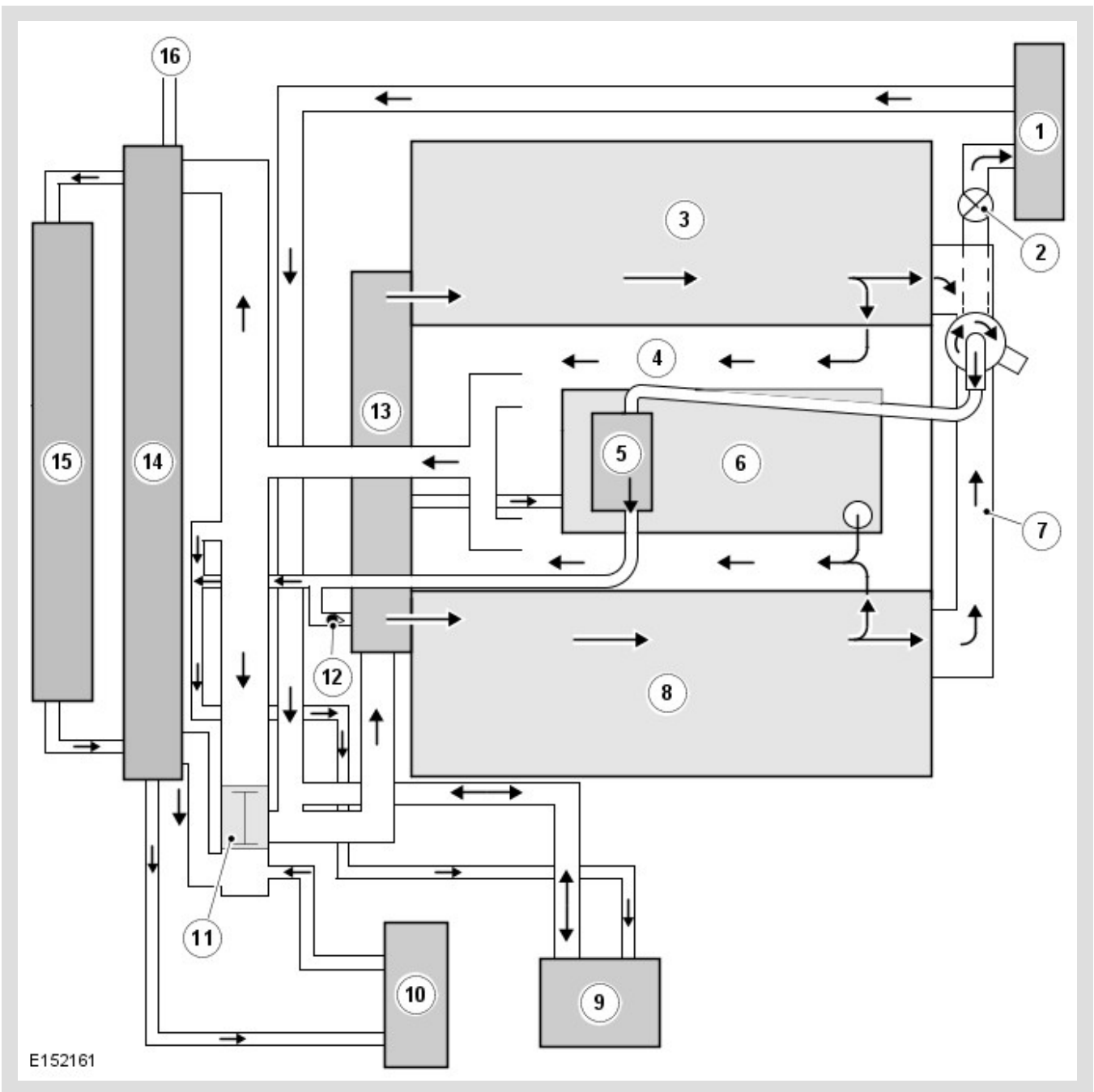

E152161

ITEM	DESCRIPTION
1	Heater Core
2	Air Bleed Screw
3	Right Cylinder Head
4	Cylinder Block
5	Throttle Housing
6	Engine Oil Cooler
7	Heater Manifold
8	Left Cylinder Head
9	Expansion Tank
10	Automatic Transmission Fluid (ATF) Cooler
11	Thermostat
12	Check Valve
13	Coolant Pump
14	Radiator
15	Auxiliary Radiator
16	Connection with Supercharger Cooling System

When the engine is running, the coolant is circulated around the engine cooling system by the coolant pump. From the coolant pump, coolant flows through the cylinder heads and the engine oil cooler into the cylinder block and the heater manifold.

In the cylinder block, the coolant flows forward to the outlet tube. When the coolant is cold the thermostat is closed, coolant flows direct from the outlet tube back to the coolant pump. When the coolant reaches operating temperature, the thermostat begins to open to control the system temperature, coolant flows from the outlet tube to the coolant pump through the radiator and, if equipped, the auxiliary radiator. When the thermostat is open, the coolant flow through the radiator(s) also generates a coolant flow through the transmission fluid cooler.

From the heater manifold the coolant flows through the electronic throttle and the heater core, in parallel circuits that are unaffected by the position of the thermostat. From the electronic throttle, the coolant merges with bleed coolant from the coolant pump and the outlet tube and flows to the expansion tank. From the heater core, the coolant flows back to the inlet of the coolant pump.

Expansion and contraction of the coolant is accommodated by an air space in the expansion tank and the compliance of the flexible hoses.

When the coolant level in the coolant expansion tank is sufficient, the magnetic float is in the top position. In this position the magnetic field closes the switch contacts in the coolant level sensor. When the coolant level drops significantly below the MIN cold fill coolant level, the magnetic float descends, thus the switch contacts disconnected. The open circuit is sensed by the Body Control Module/Gateway Module (BCM/GWM), which sends a signal to the Instrument Cluster (IC) to display the "Coolant Level Low" warning message. The message is sent on the High Speed (HS) Controller Area Network (CAN) comfort systems bus.

For additional information, refer to: [Instrument Cluster](#) (413-01 Instrument Cluster, Description and Operation).

The cooling fan is operated by a fan control module integrated into the cooling fan motor. The fan control module regulates the voltage, and thus speed, of the cooling fan motor in response to a PWM signal from the ECM. The cooling fan motor also provides a diagnostic feedback to the ECM through the PWM connection.

The electric cooling fan receives a battery feed and an ignition feed from the engine junction box (EJB). The ignition feed is supplied from the ignition relay in the EJB, which is controlled by the ECM.

The ECM calculates the required fan speed from the engine temperature, air conditioning (A/C) system pressure and automatic transmission fluid temperature. Under hot operating conditions, the fan may continue to operate for 4 minutes after the engine has been switched off.

The supercharger cooling system also uses the engine cooling system for charge air cooling.

INPUT AND OUTPUT CONTROL DIAGRAM



NOTE:

A = Hardwired; **AJ** = PWM

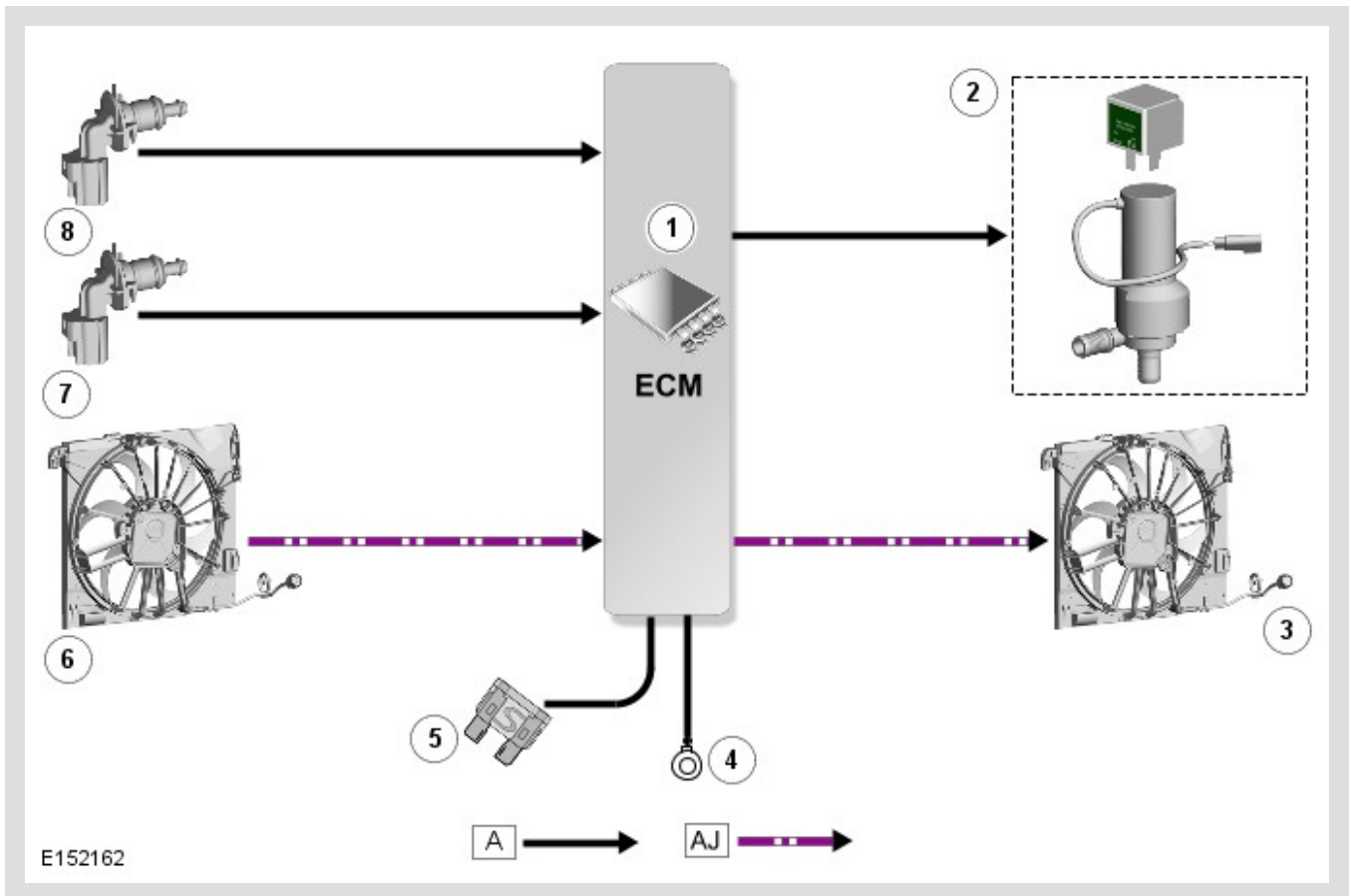

E152162

ITEM	DESCRIPTION
1	Engine Control Module
2	Charge Air Coolant Pump
3	Radiator Fan
4	Ground
5	Power Supply
6	Radiator Fan
7	Engine Coolant Temperature Sensor 1
8	Engine Coolant Temperature Sensor 2