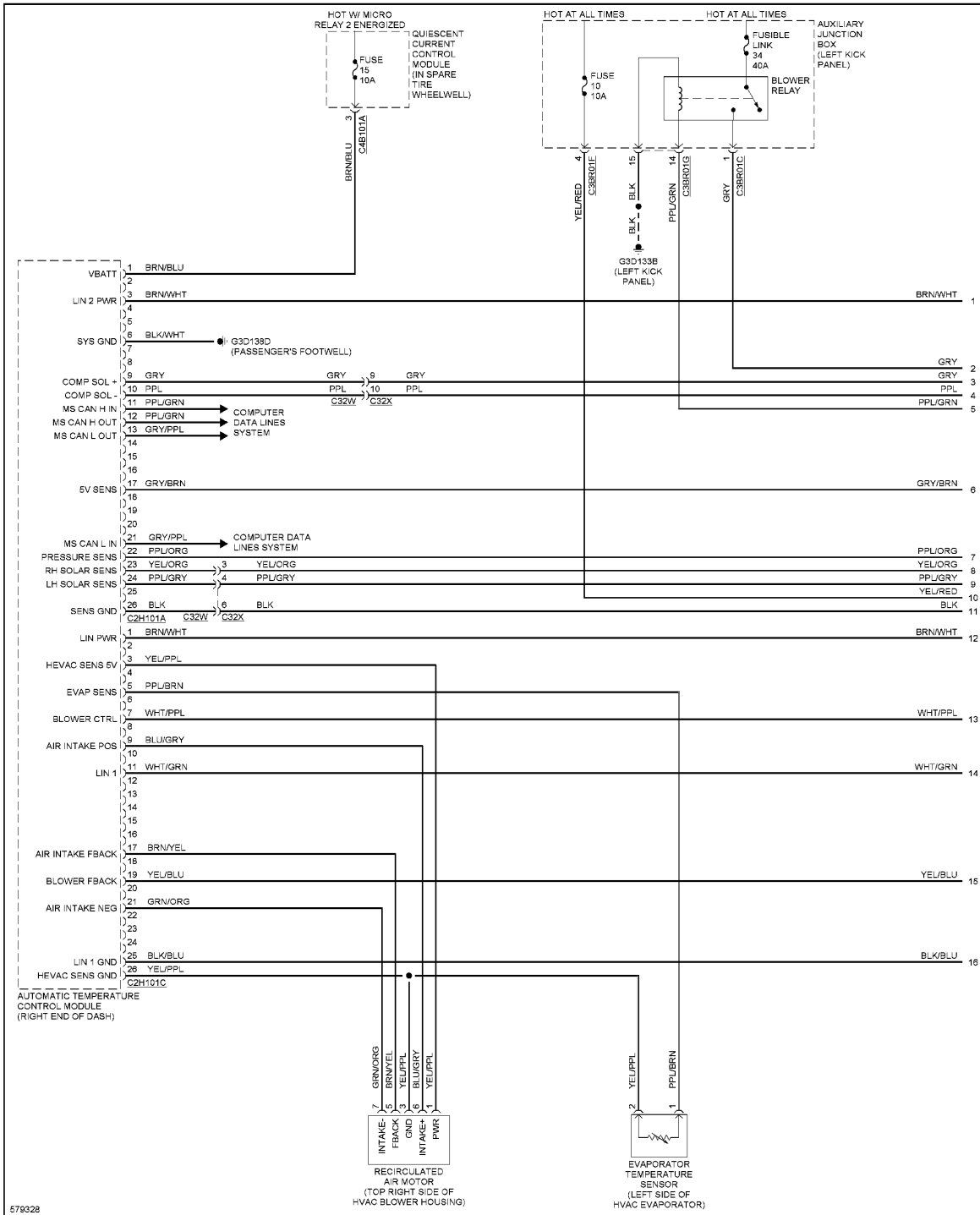


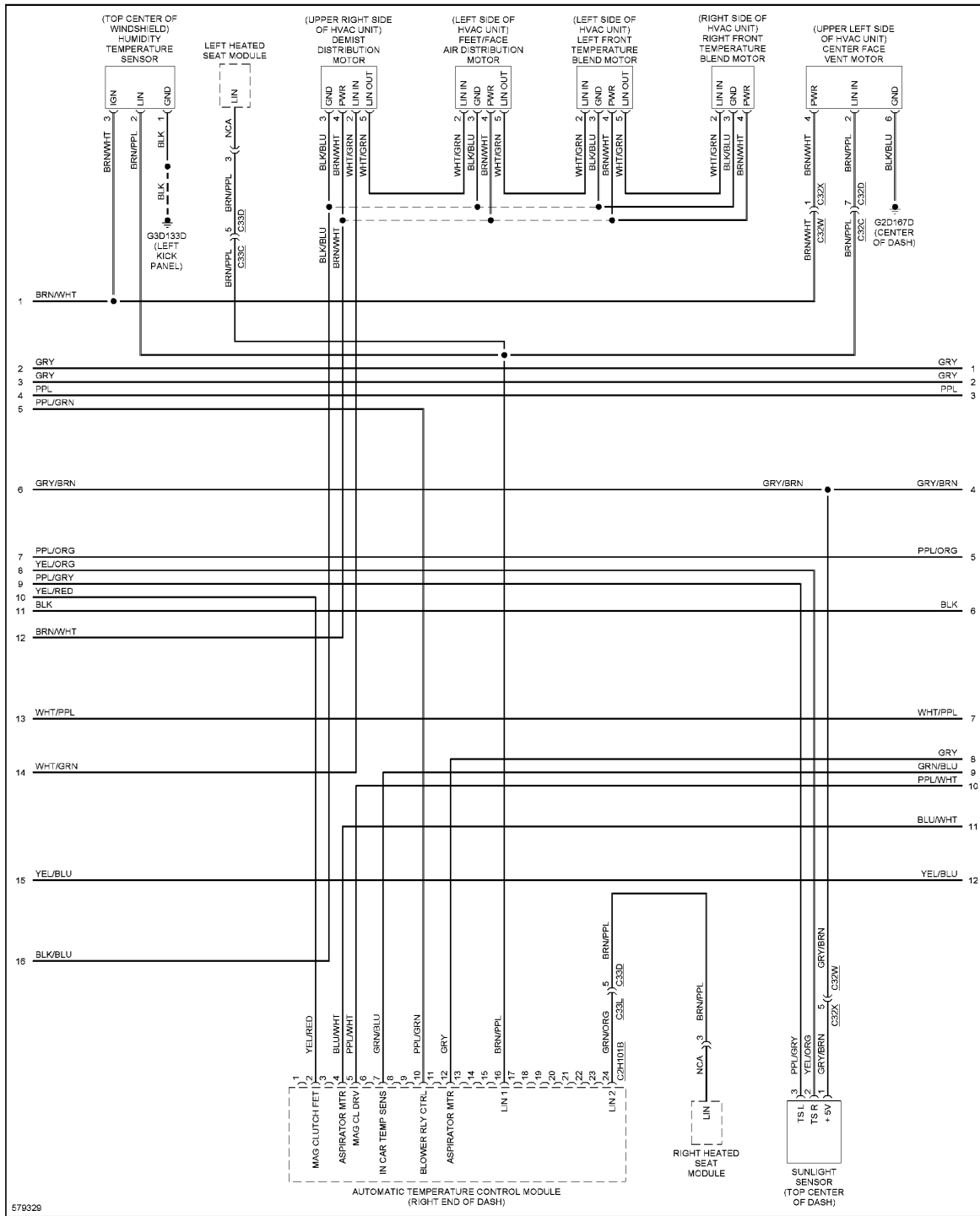
# 2017 SYSTEM WIRING DIAGRAMS

## Jaguar - F-Type

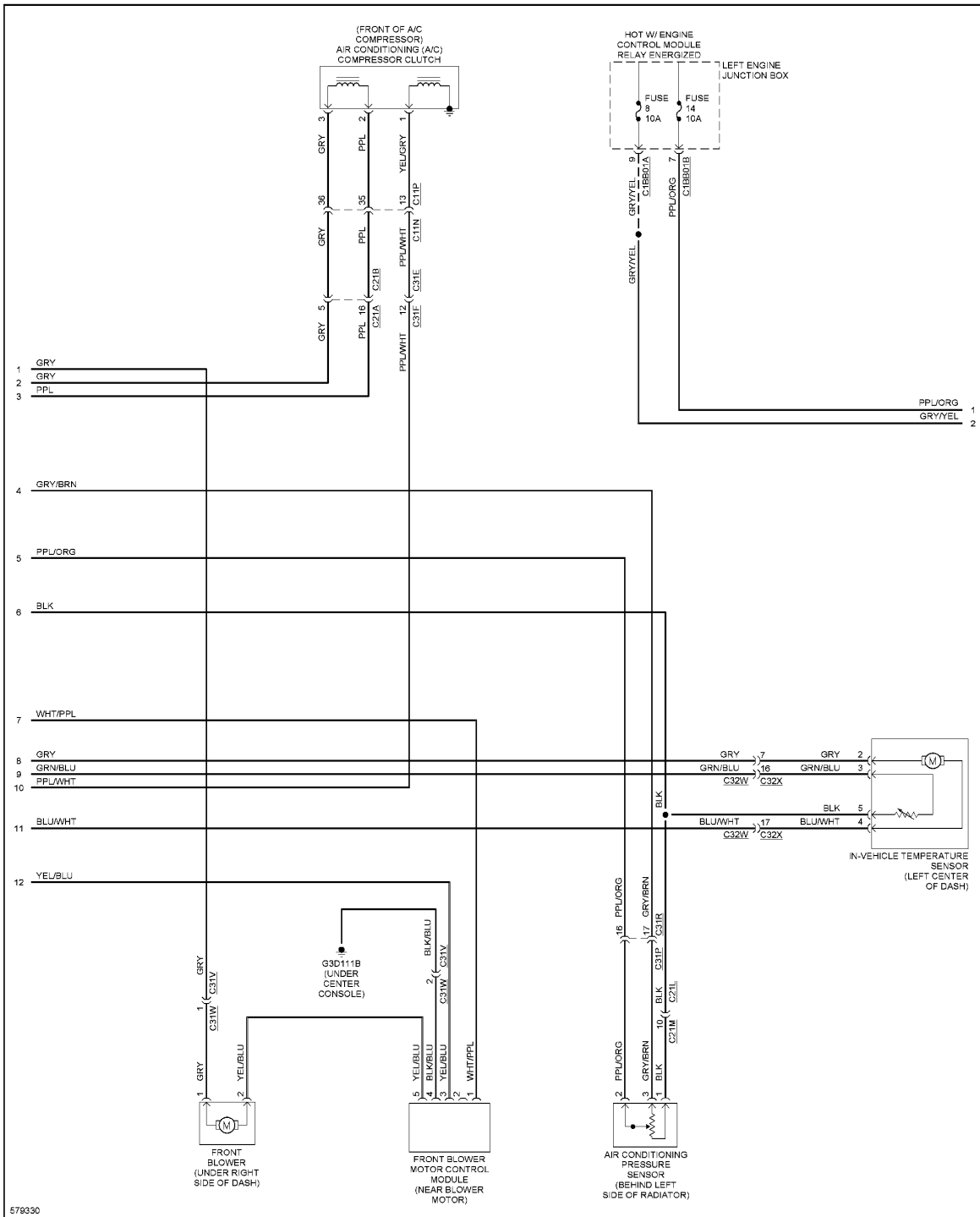
### AIR CONDITIONING



**Fig. 1: Automatic A/C Circuit (1 of 4)**



**Fig. 2: Automatic A/C Circuit (2 of 4)**



**Fig. 3: Automatic A/C Circuit (3 of 4)**

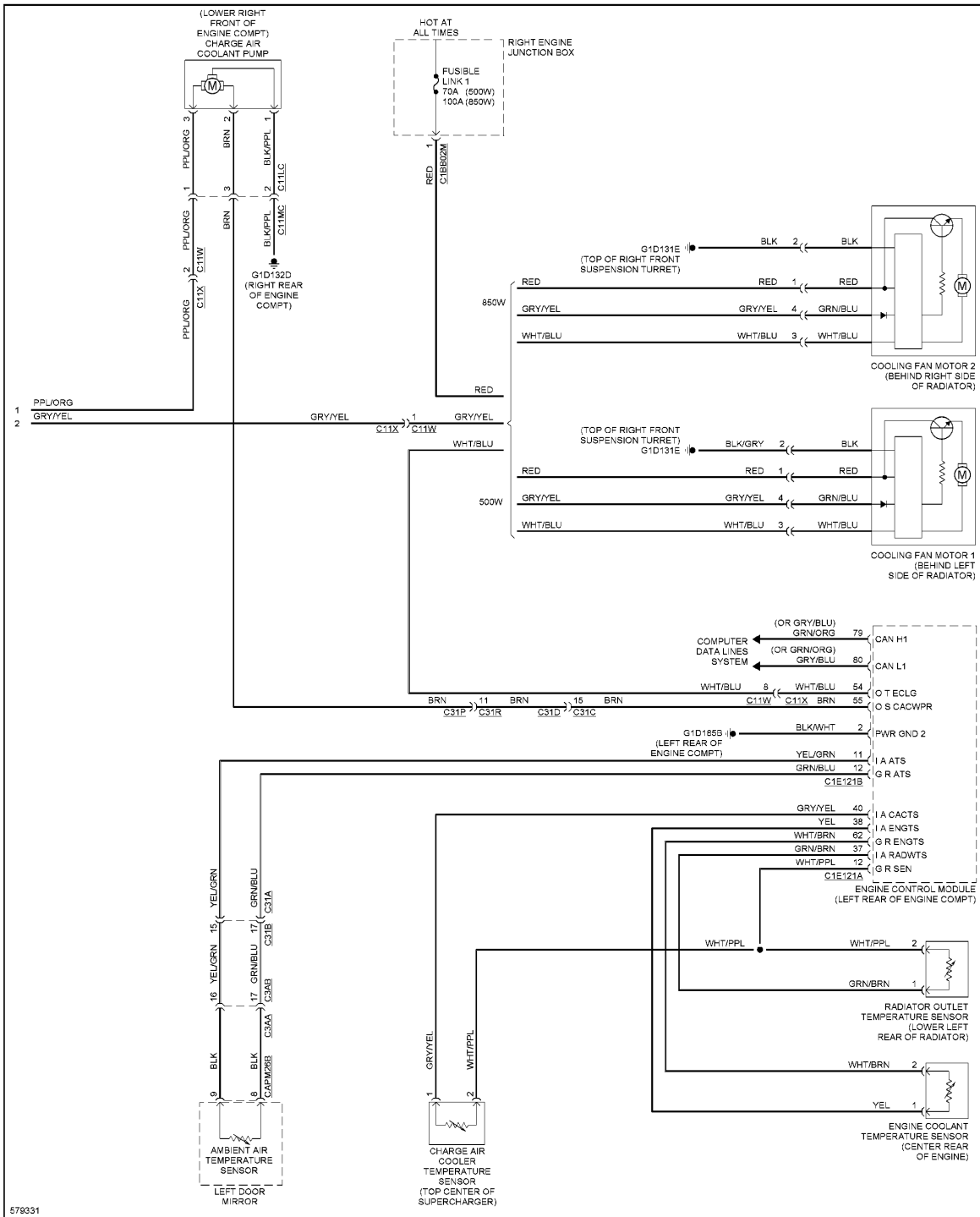


Fig. 4: Automatic A/C Circuit (4 of 4)

## ANTI-LOCK BRAKES



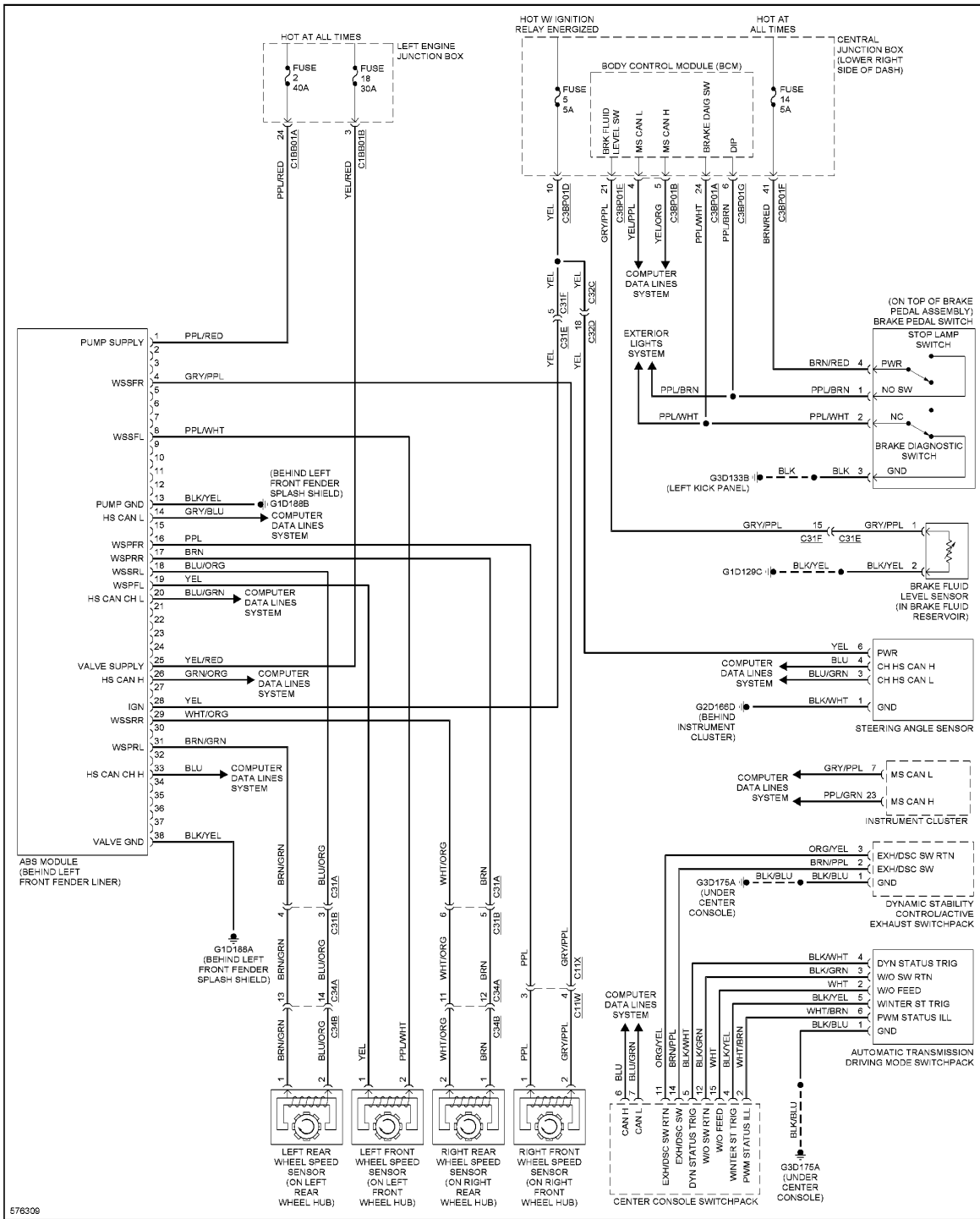


Fig. 5: Anti-lock Brakes Circuit

## ANTI-THEFT

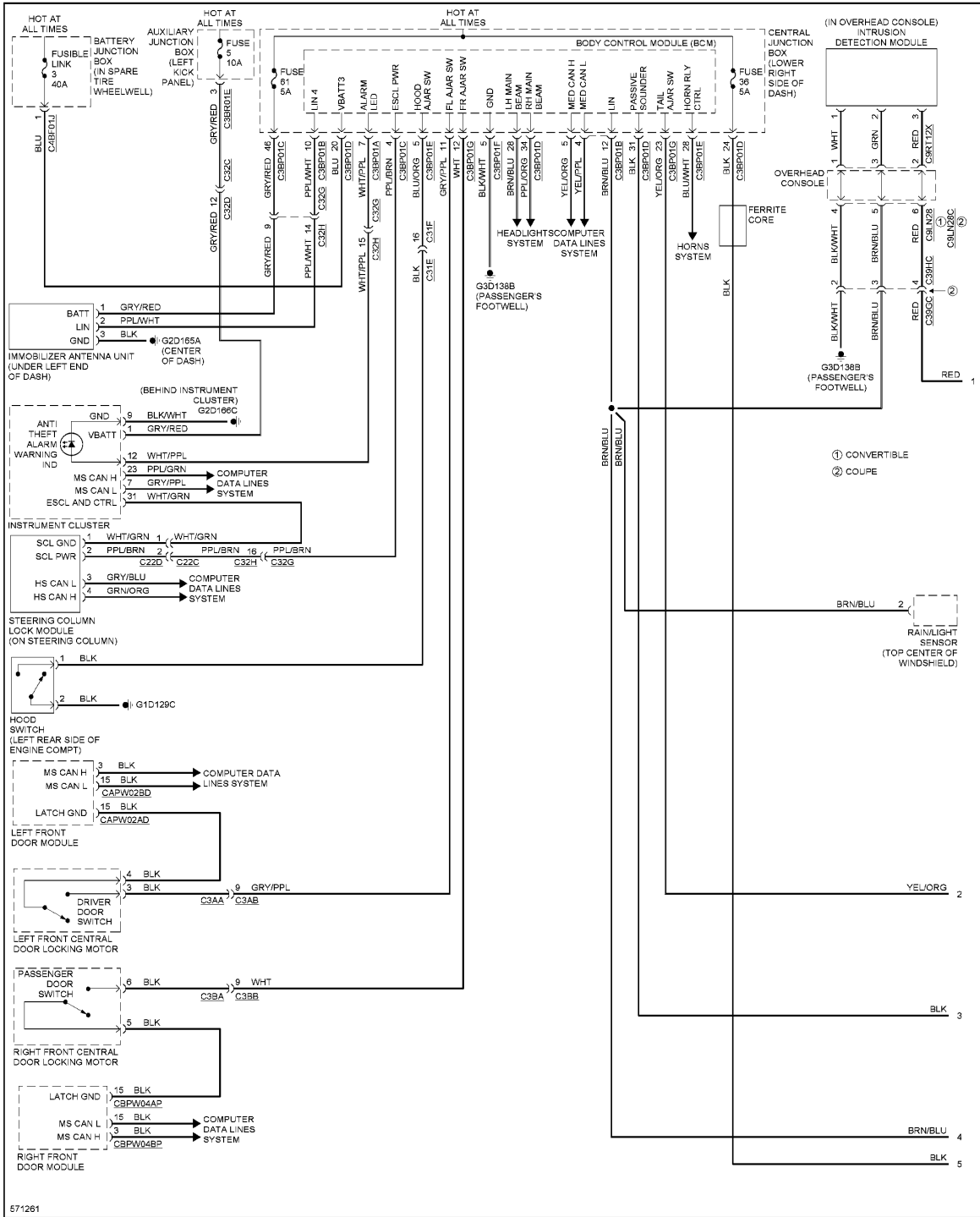


Fig. 6: Anti-theft Circuit (1 of 2)

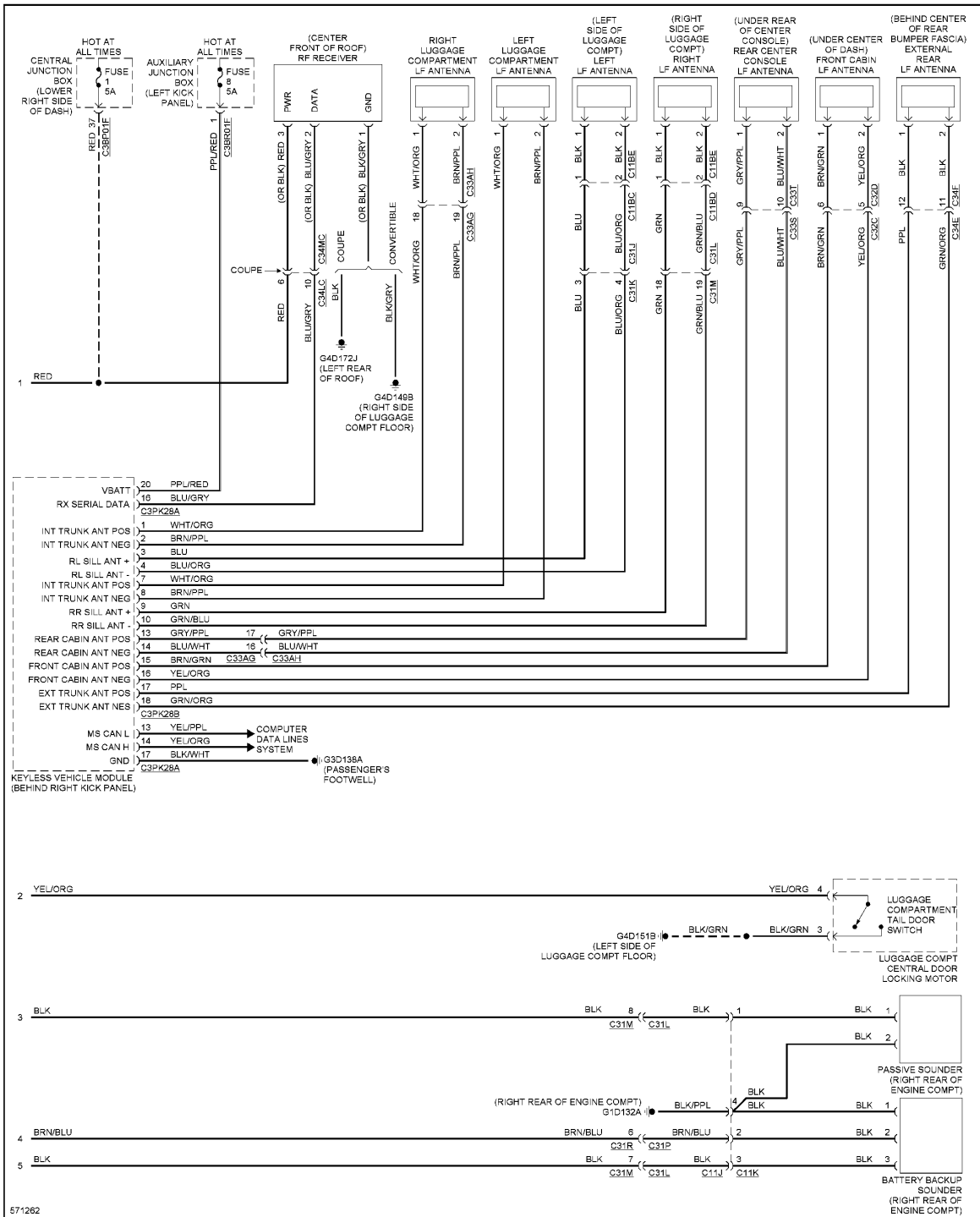
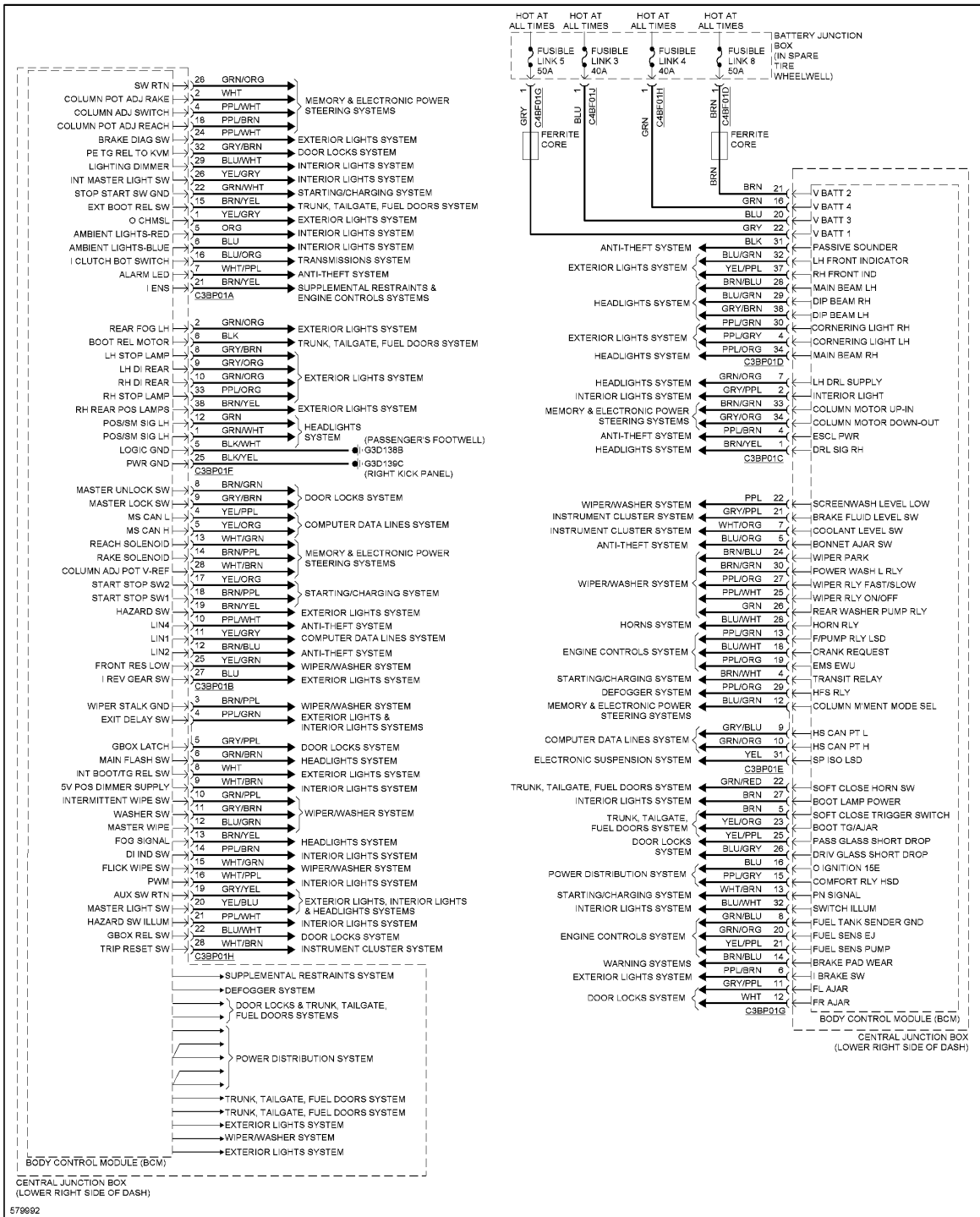


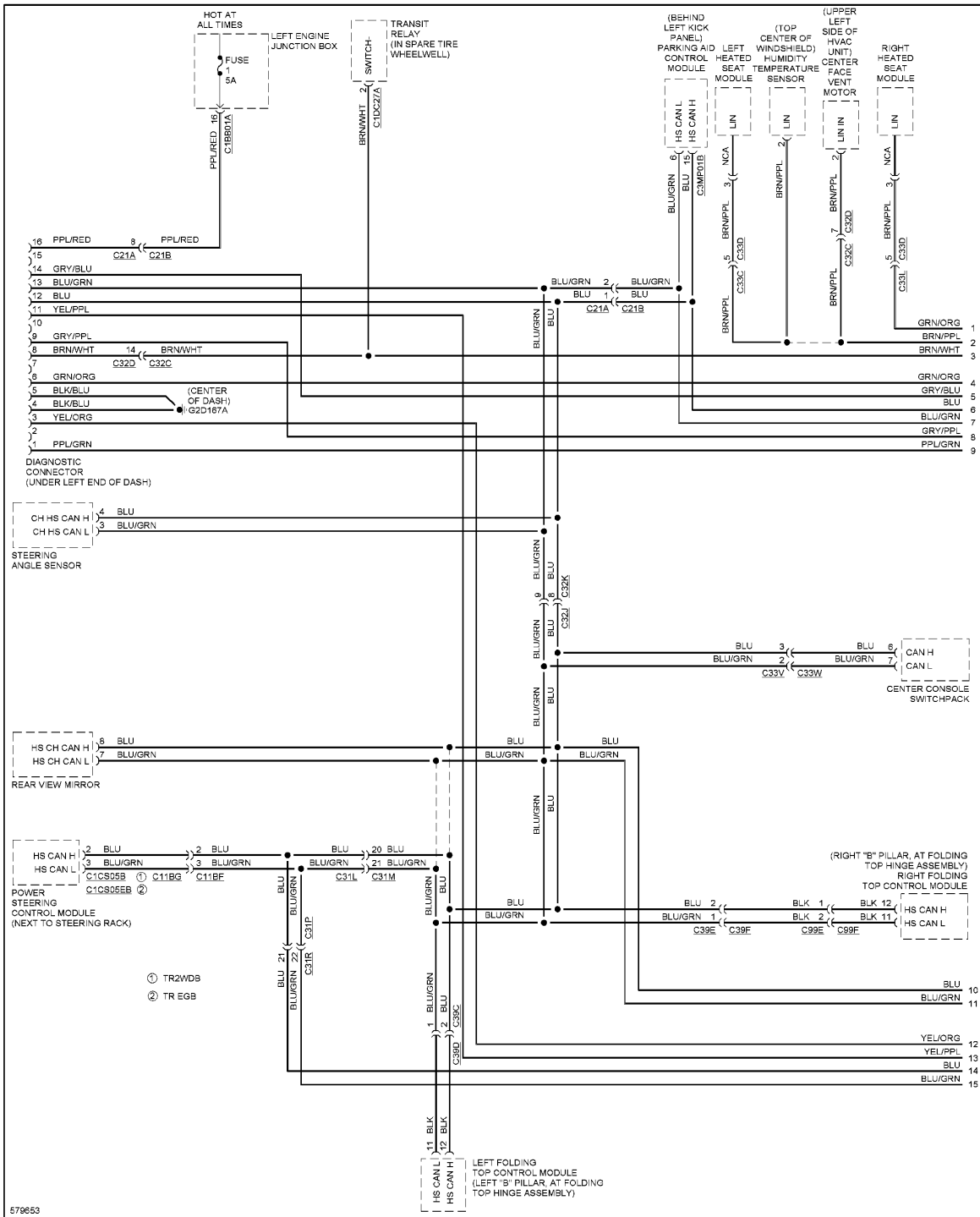
Fig. 7: Anti-theft Circuit (2 of 2)

## BODY CONTROL MODULES

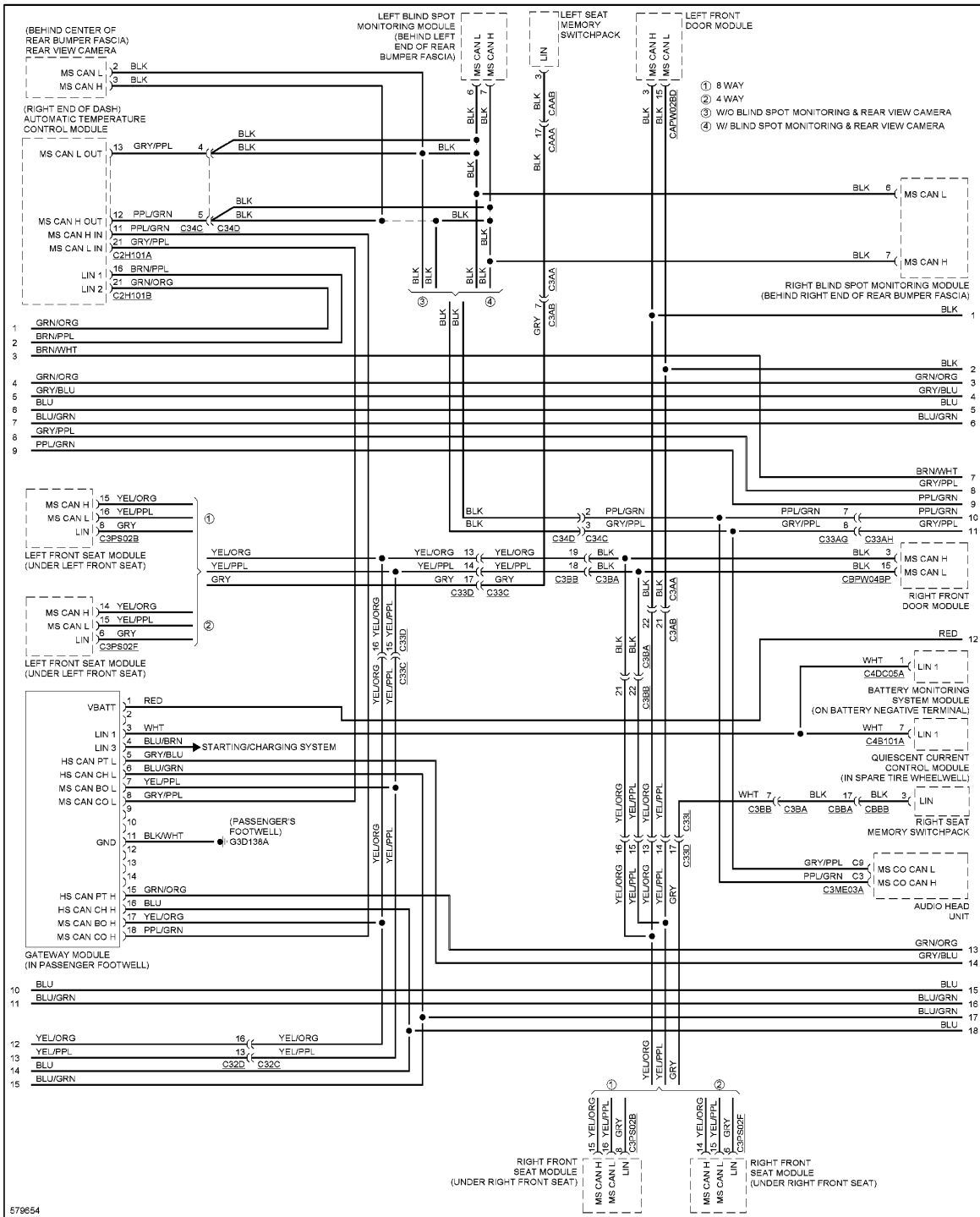


**Fig. 8: Body Control Modules Circuit**

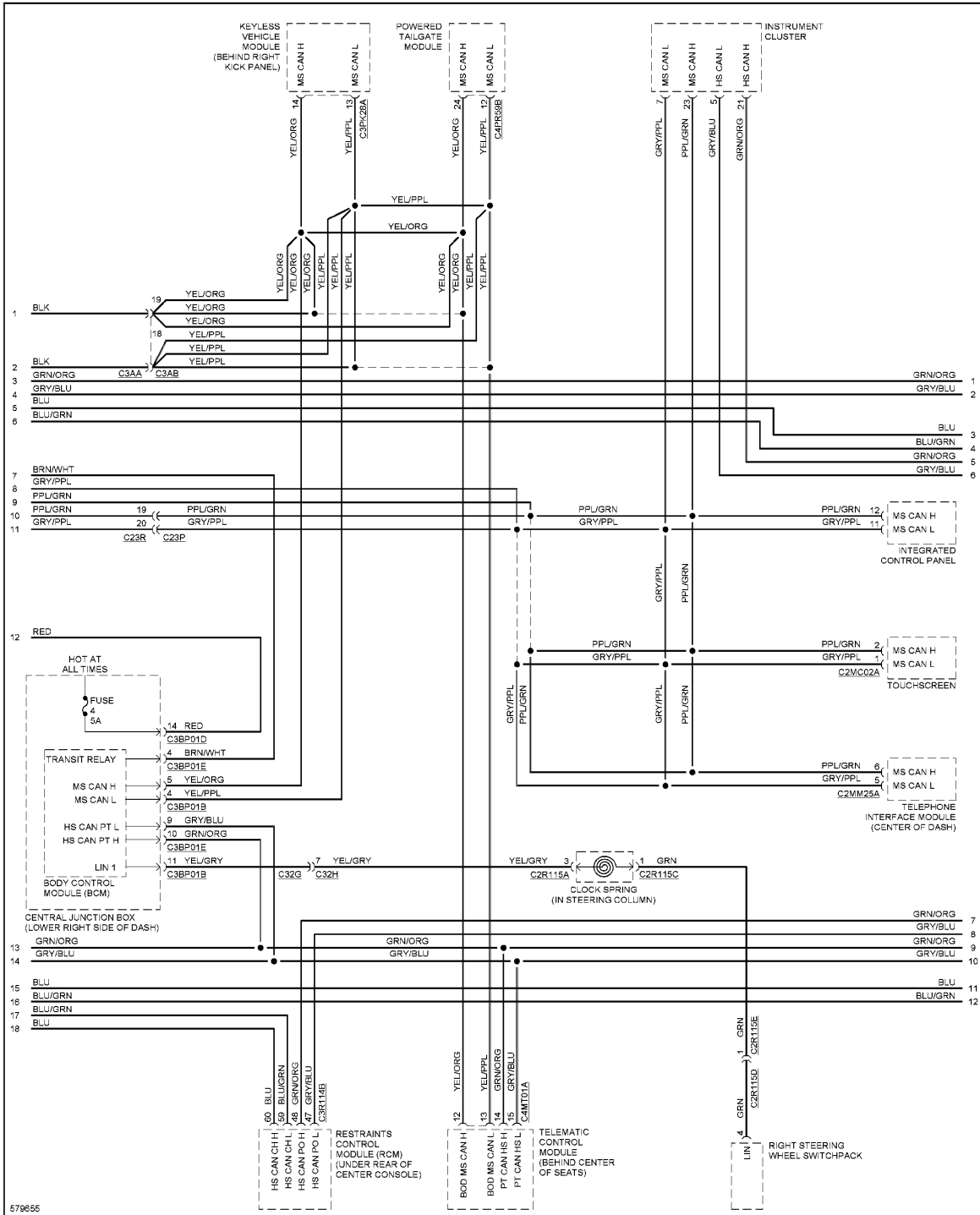
**COMPUTER DATA LINES**



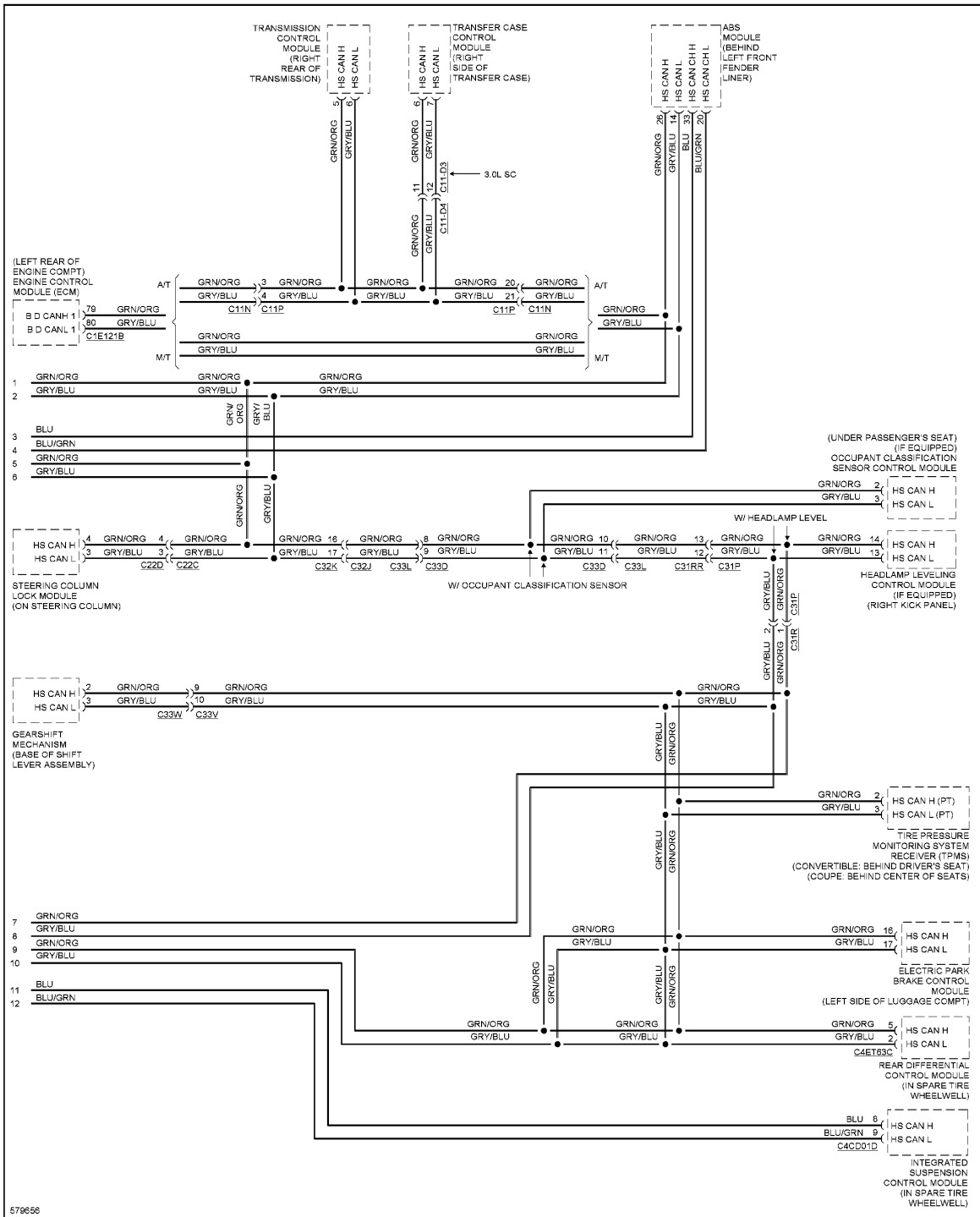
**Fig. 9: Diagnostic Socket Circuit (1 of 4)**



**Fig. 10: Diagnostic Socket Circuit (2 of 4)**

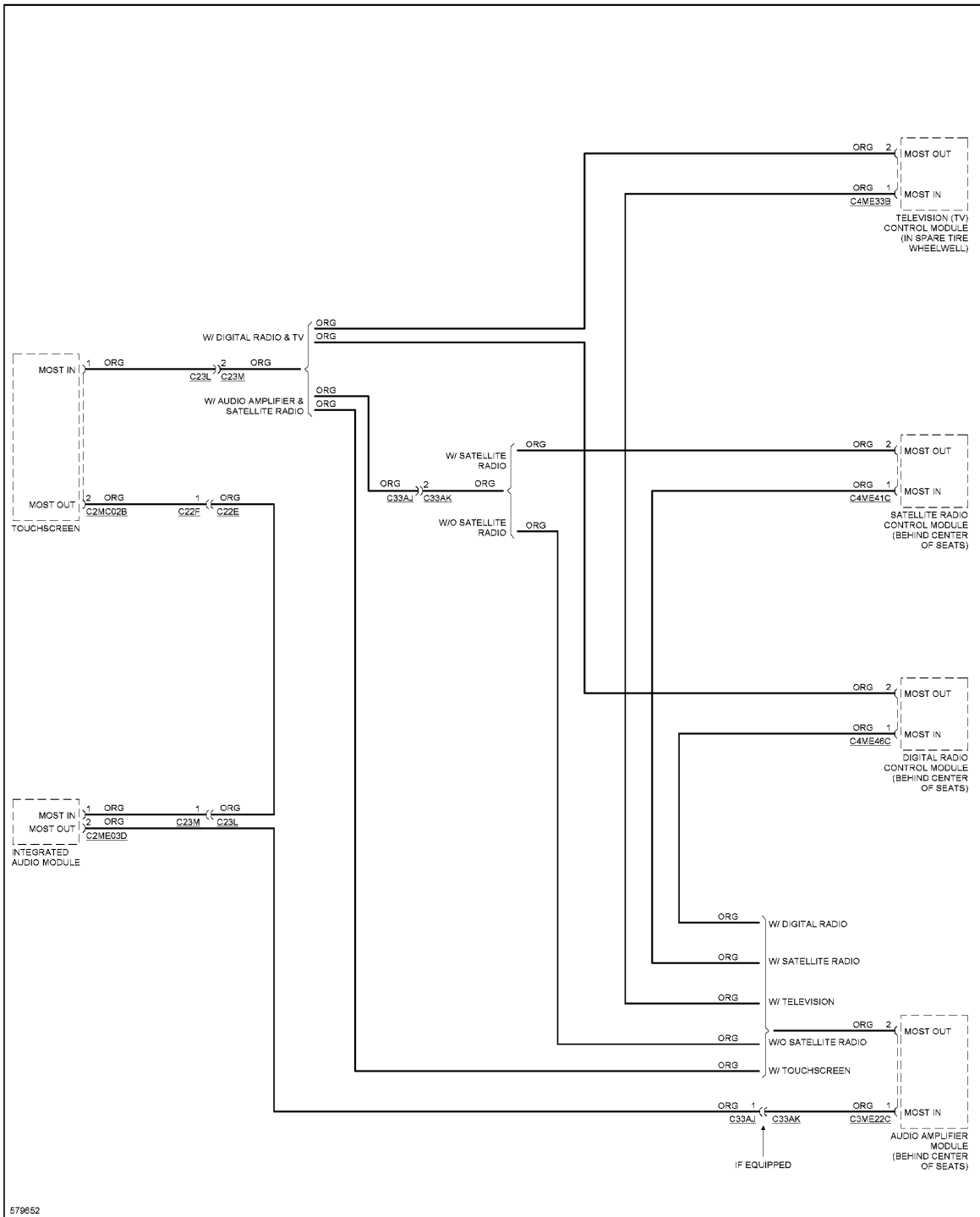


**Fig. 11: Diagnostic Socket Circuit (3 of 4)**

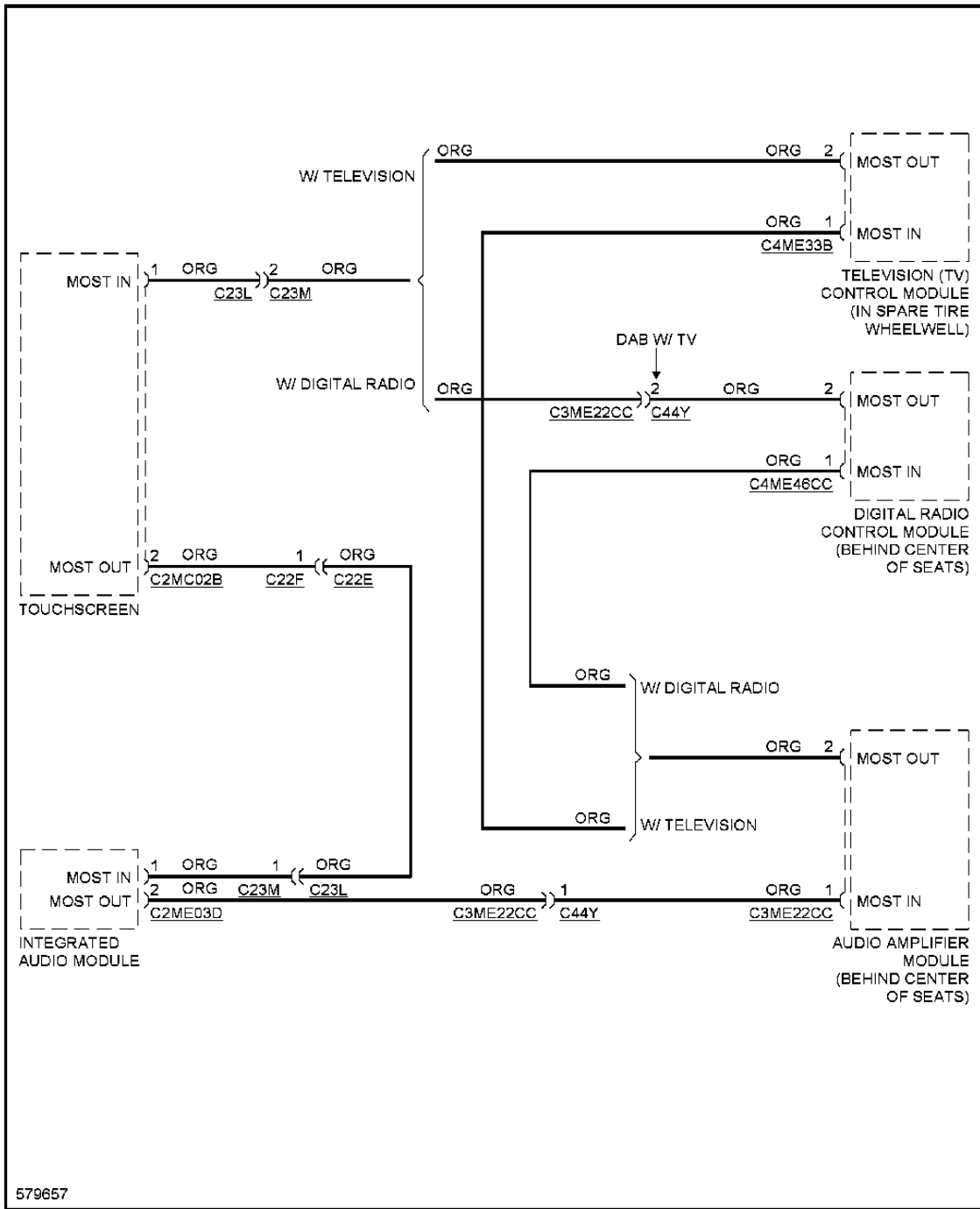


**Fig. 12: Diagnostic Socket Circuit (4 of 4)**



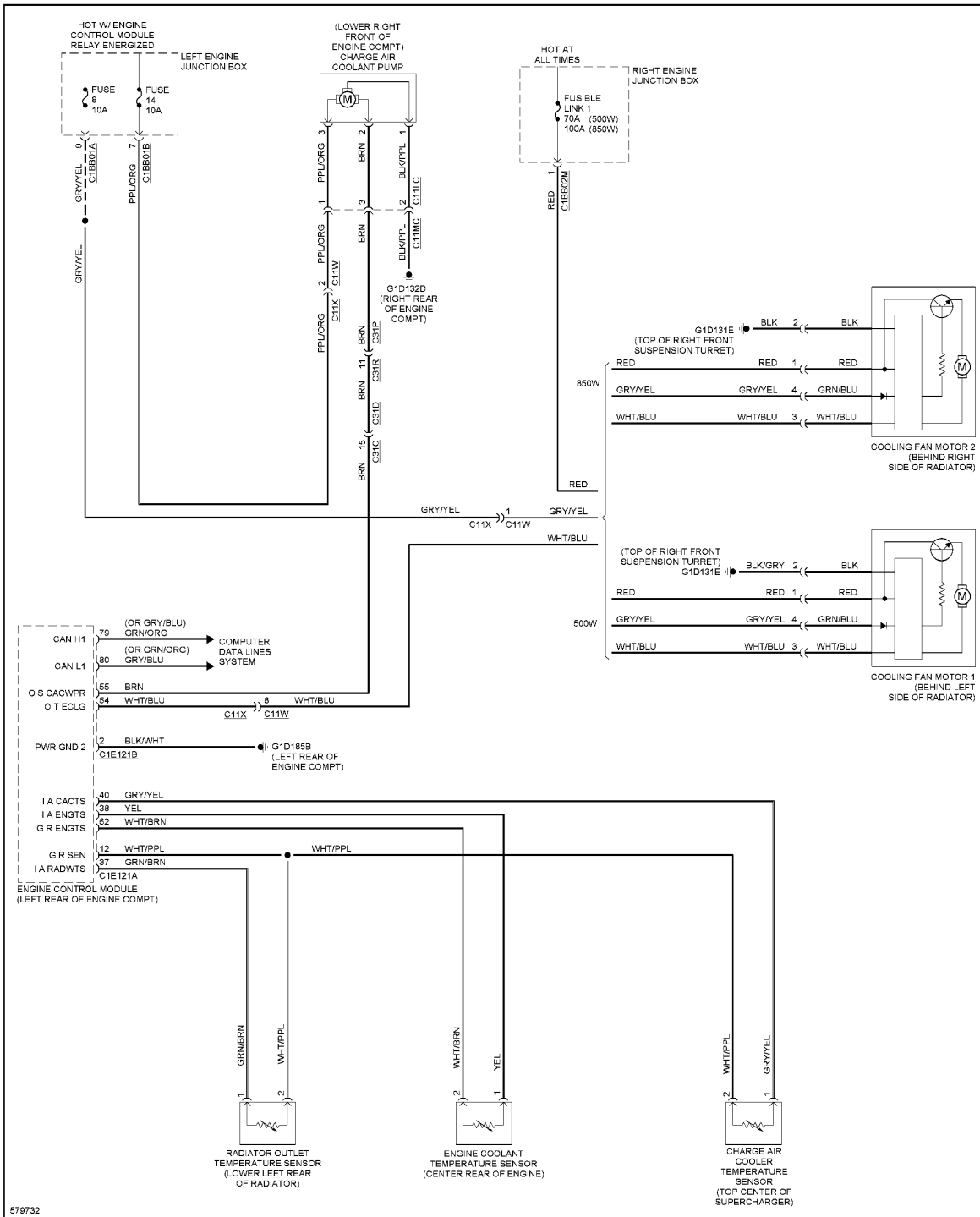


**Fig. 13: Fibre Optic Network Circuit, Convertible**



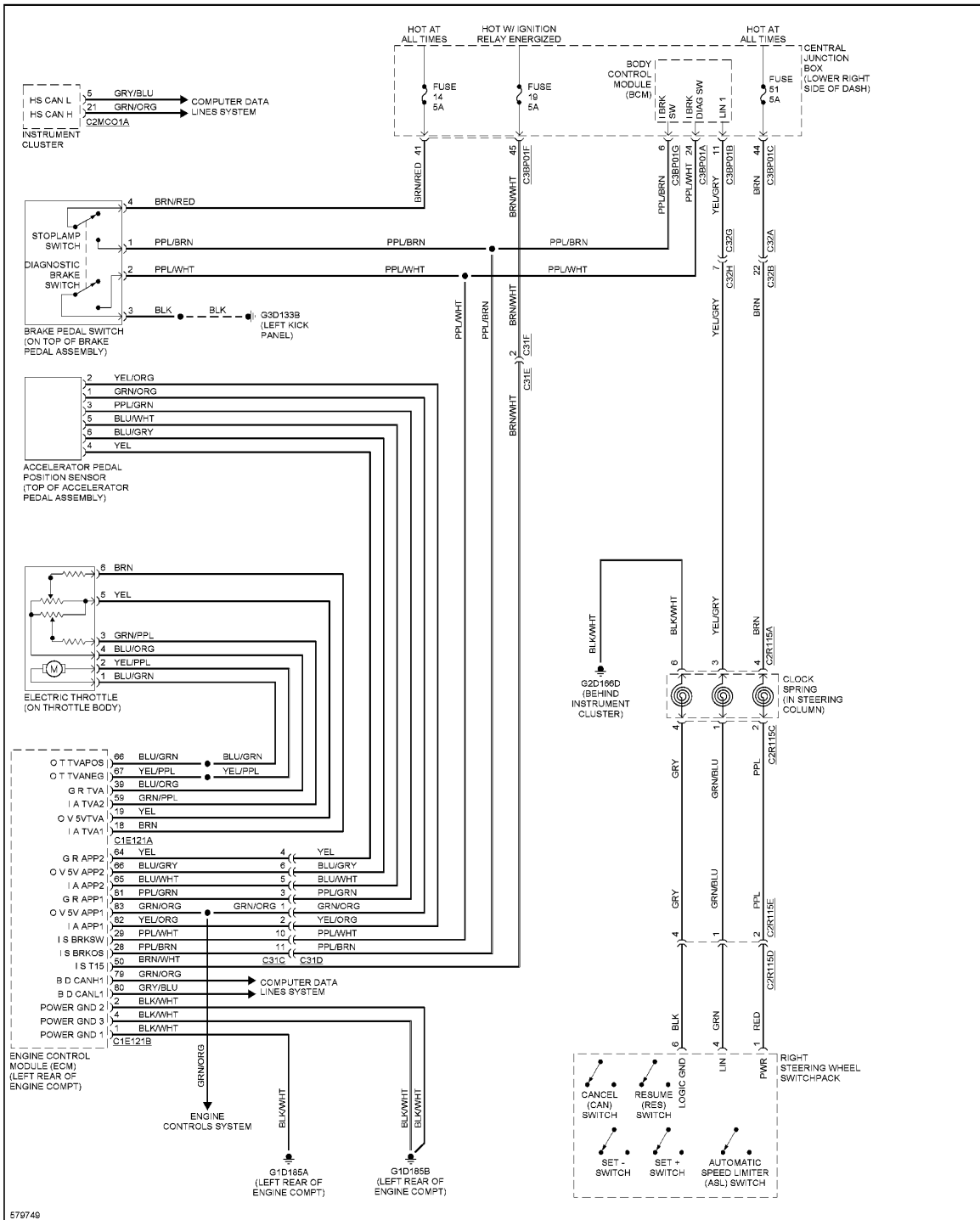
**Fig. 14: Fibre Optic Network Circuit, Coupe**

**COOLING FAN**



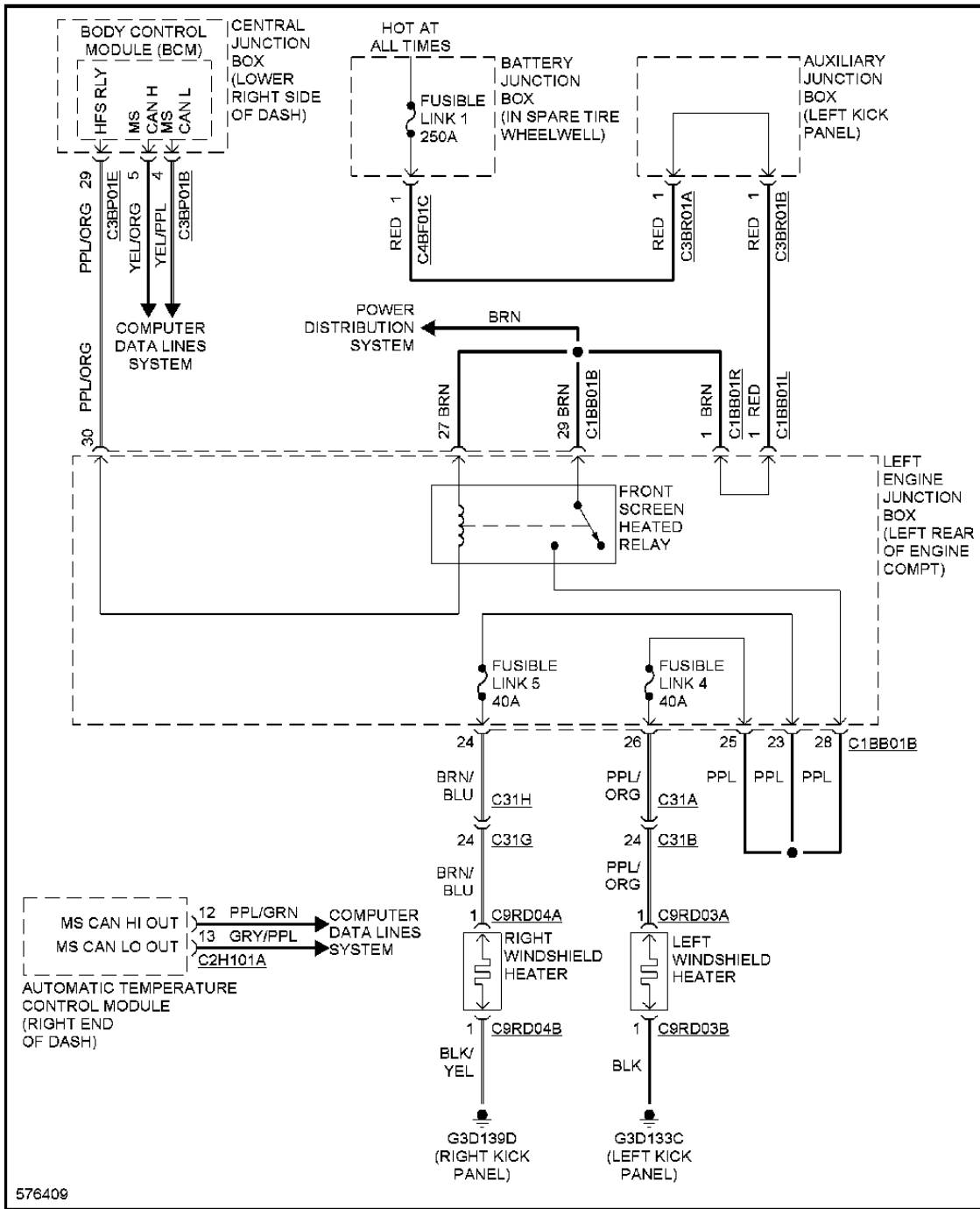
**Fig. 15: Cooling Fan Circuit**

## CRUISE CONTROL



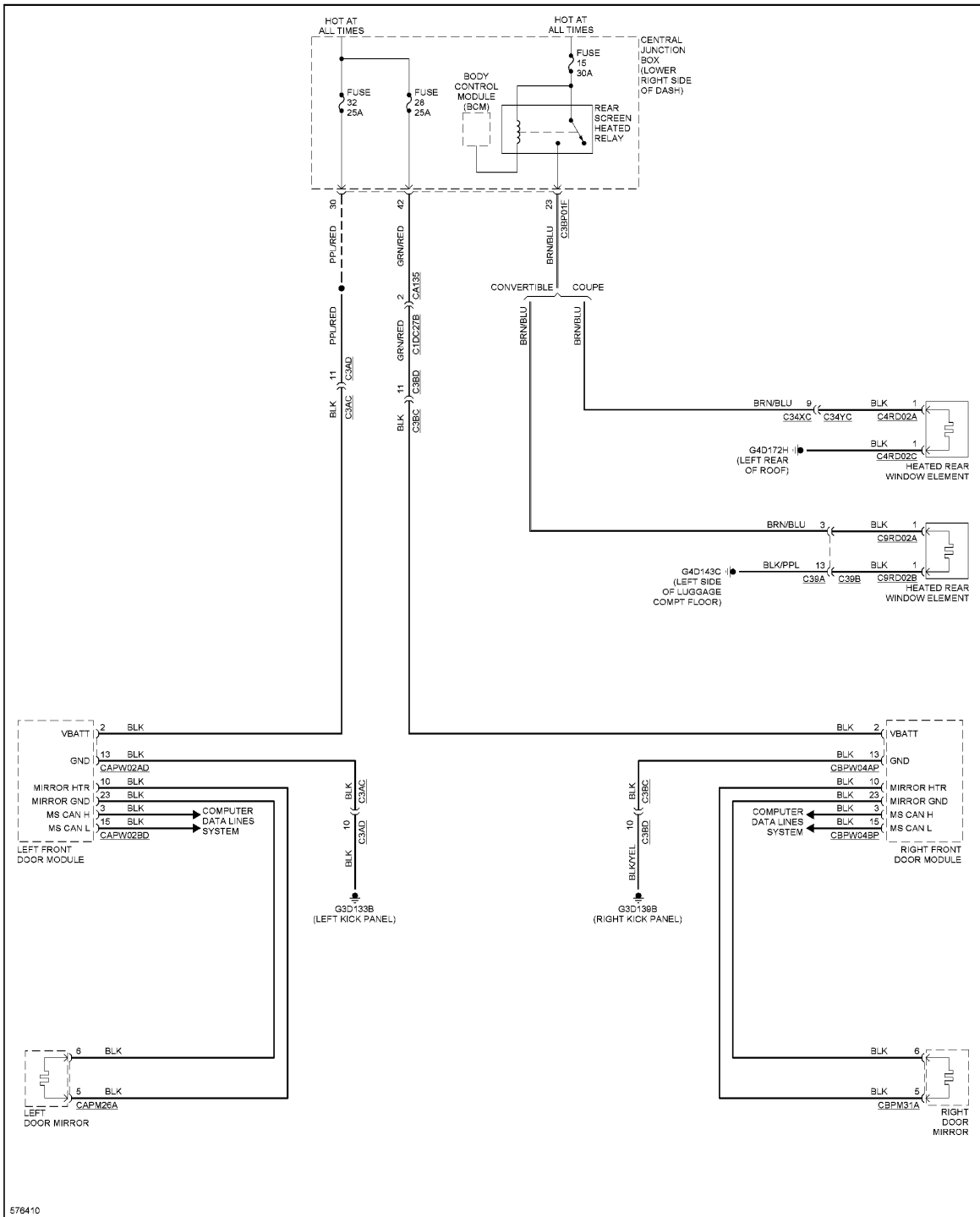
**Fig. 16: Cruise Control Circuit**

## DEFOGGERS



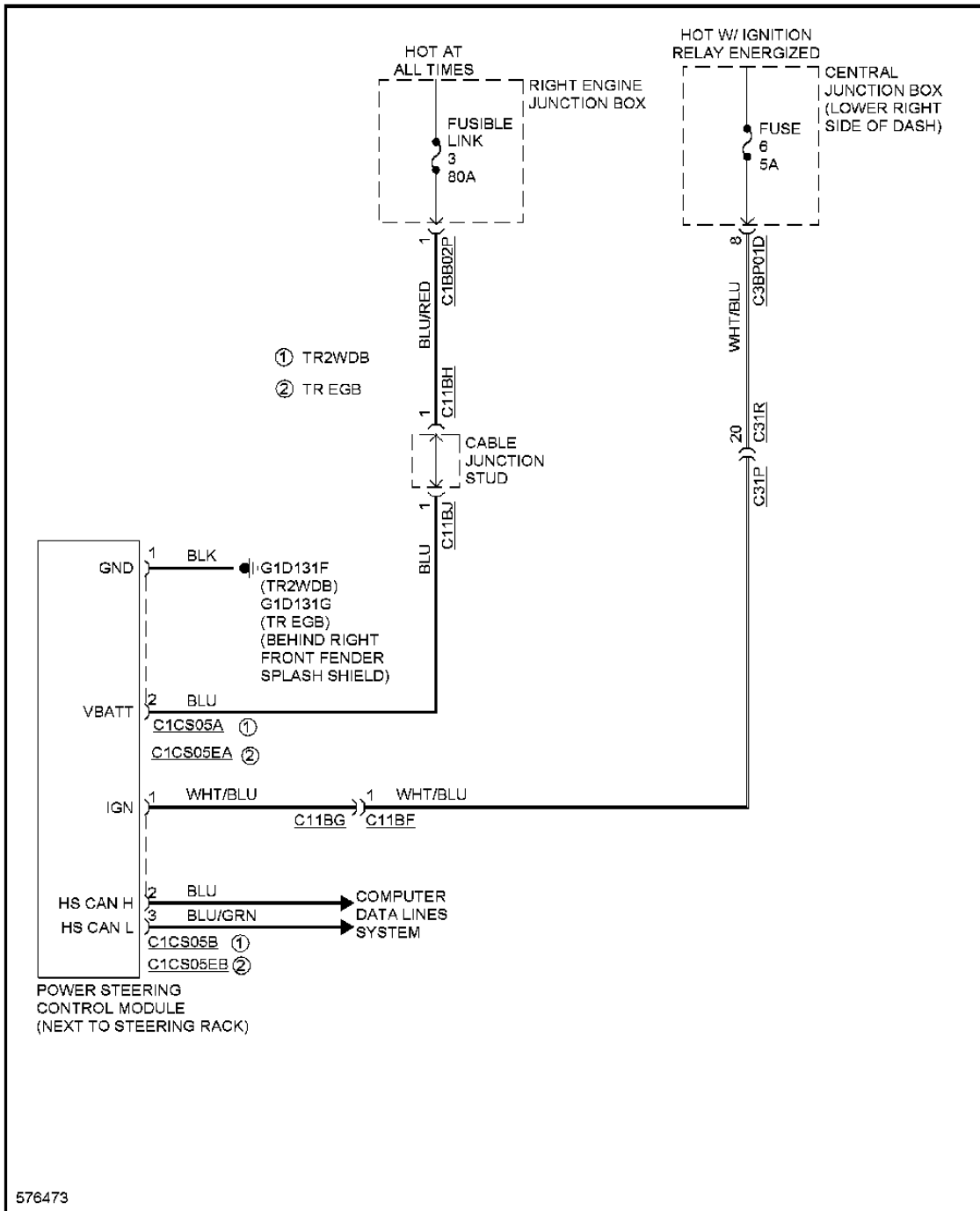
576409

**Fig. 17: Heated Windshield Circuit**

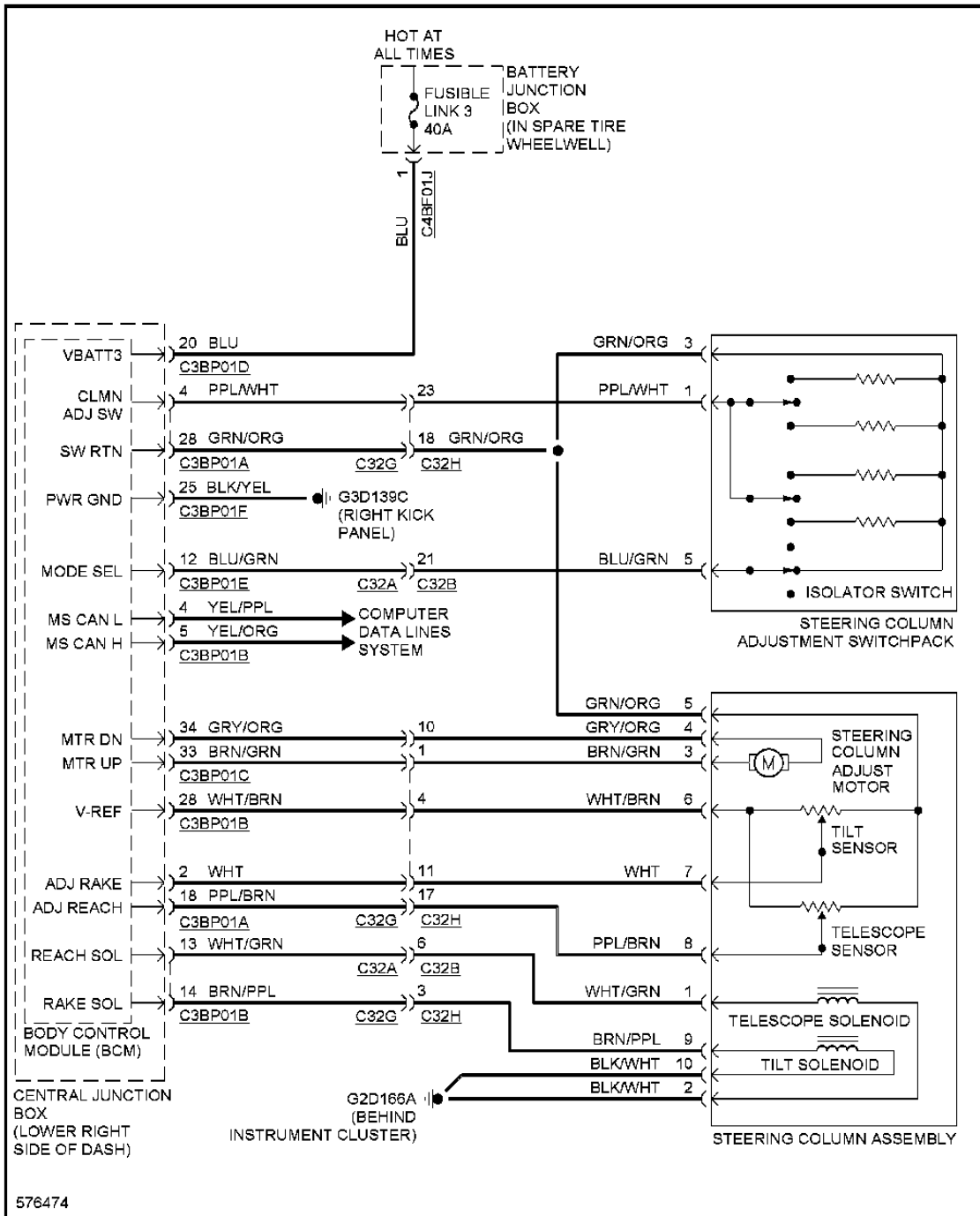


**Fig. 18: Rear Defogger & Heated Mirrors Circuit**

## **ELECTRONIC POWER STEERING**



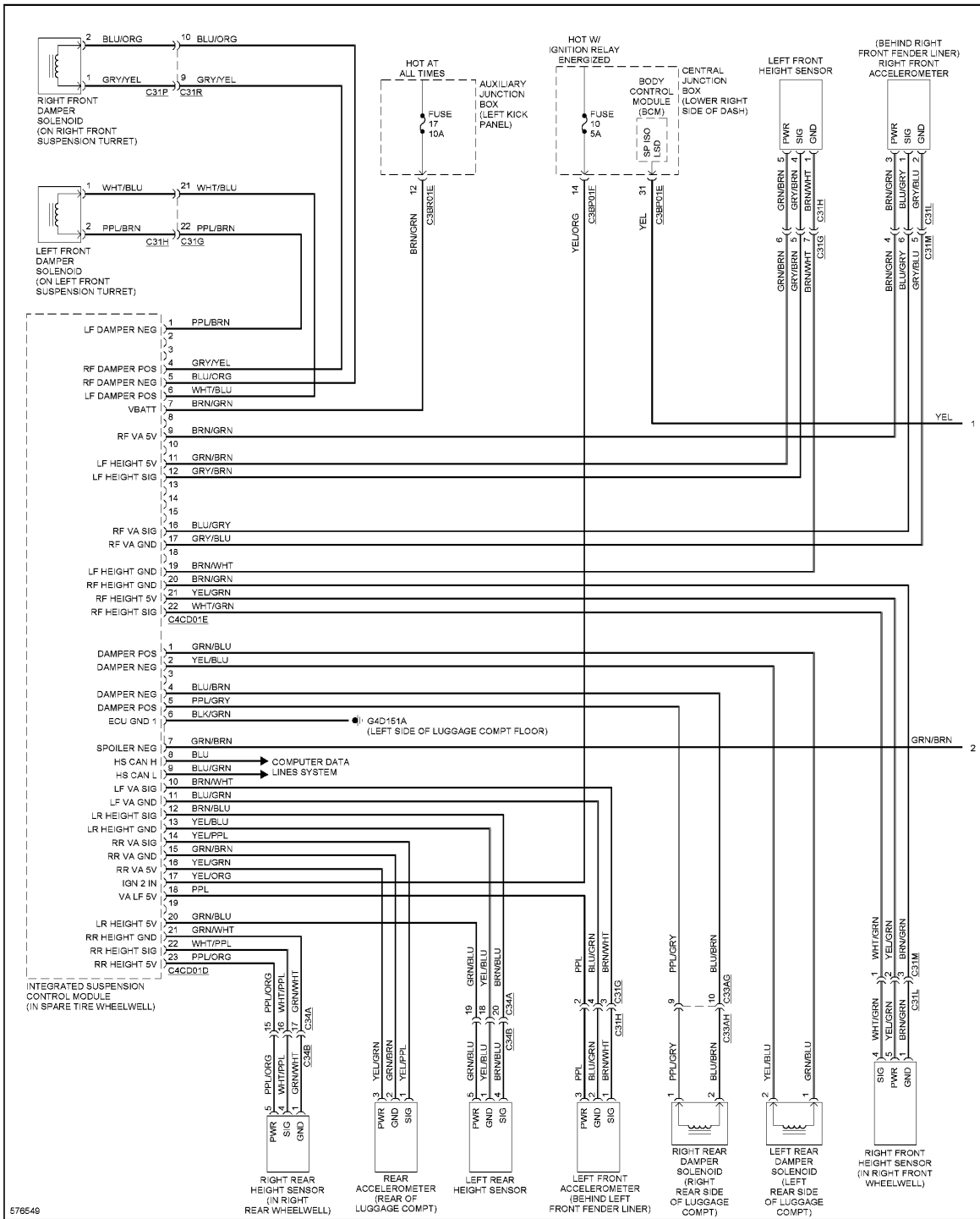
**Fig. 19: Electronic Power Steering Circuit**



**Fig. 20: Steering Column Adjustment Circuit**

**ELECTRONIC SUSPENSION**





**Fig. 21: Electronic Suspension Circuit (1 of 2)**

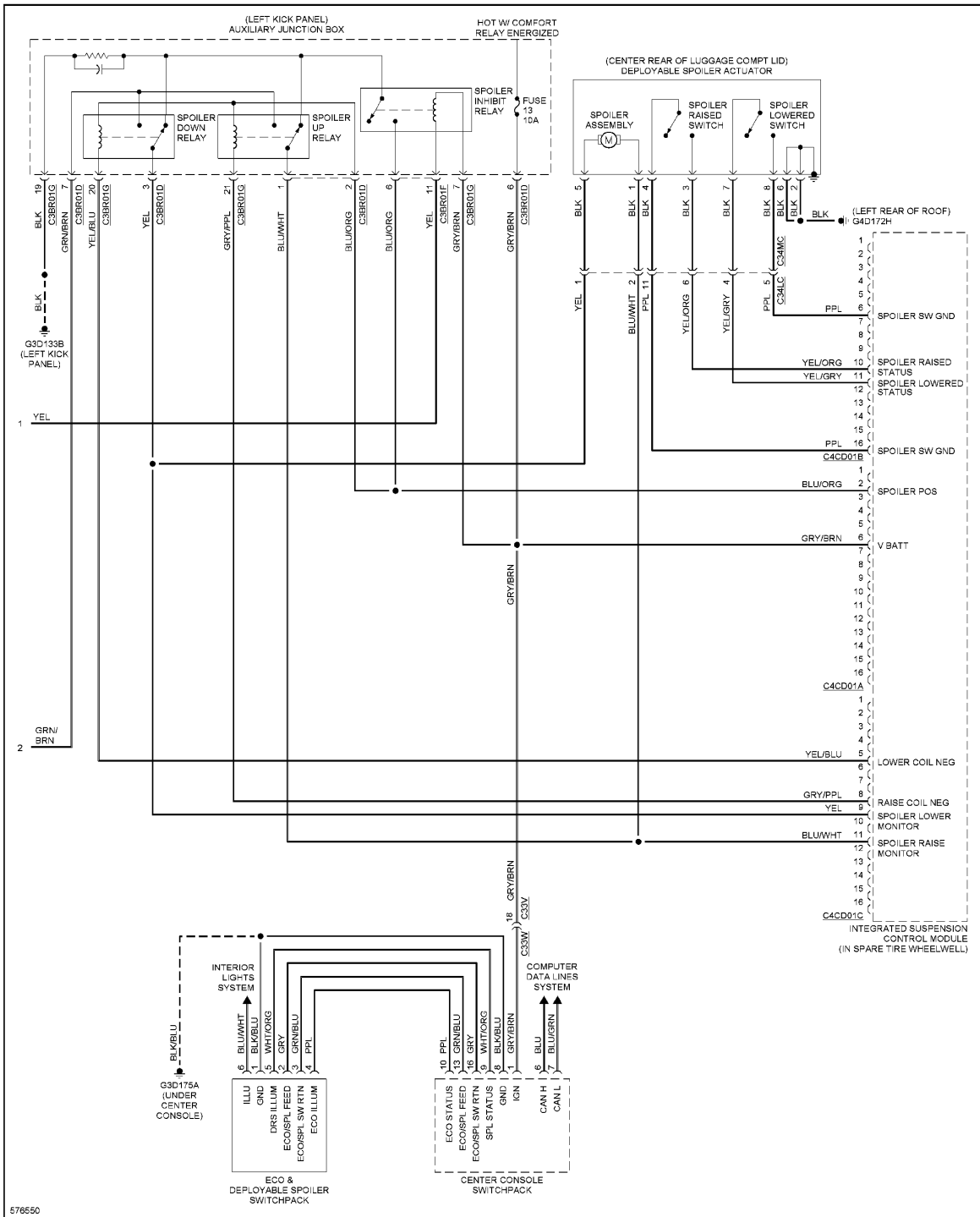
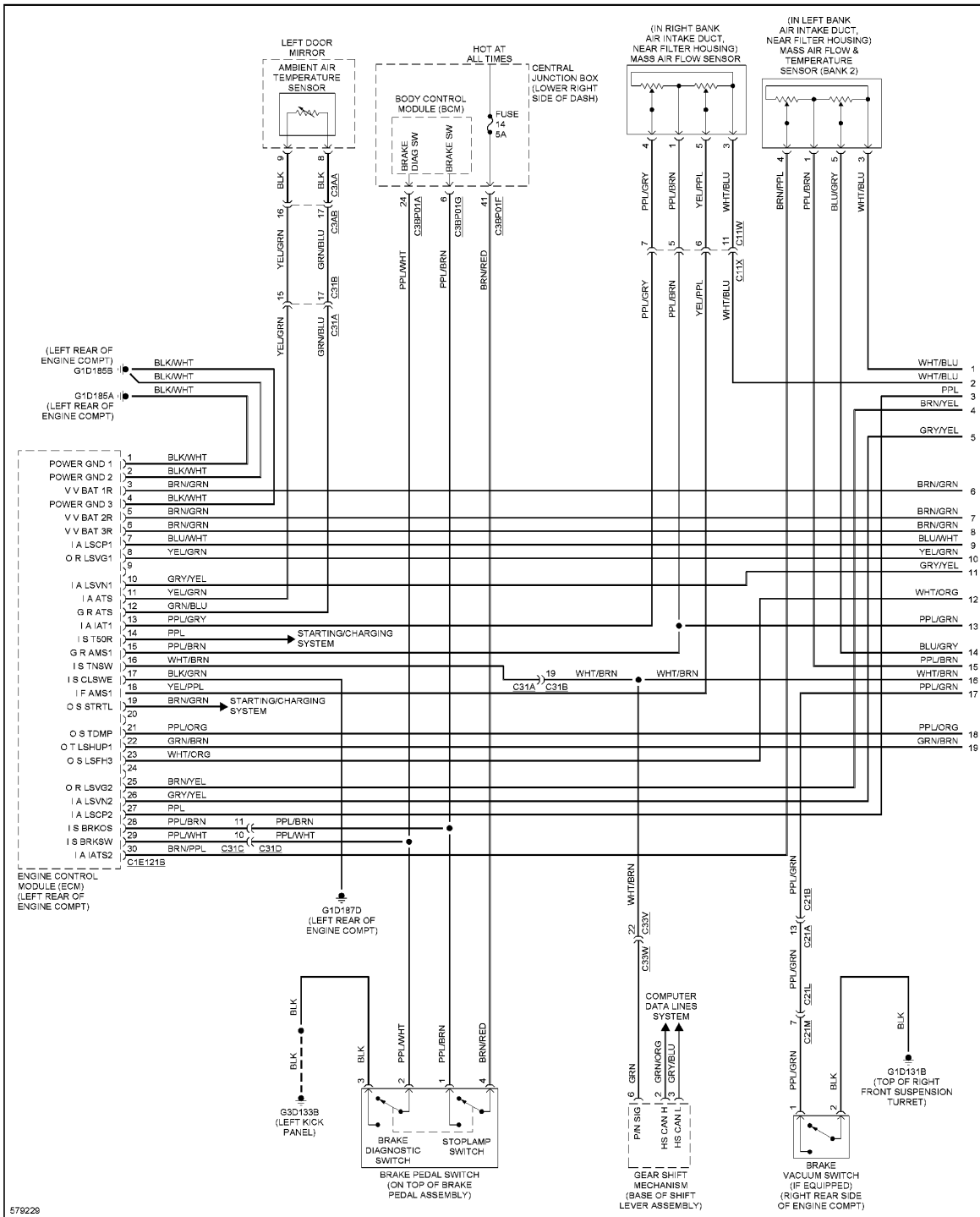


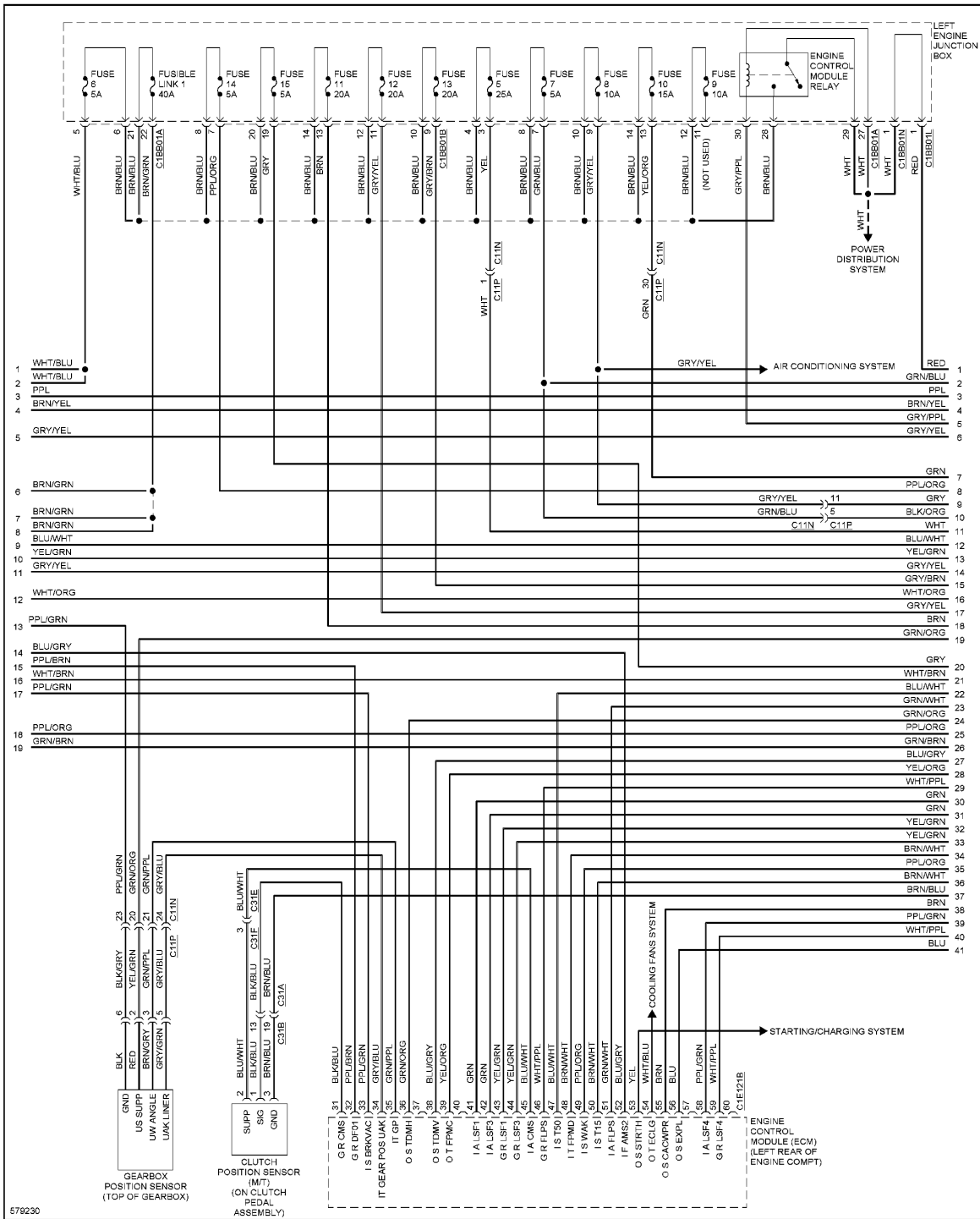
Fig. 22: Electronic Suspension Circuit (2 of 2)

## ENGINE PERFORMANCE

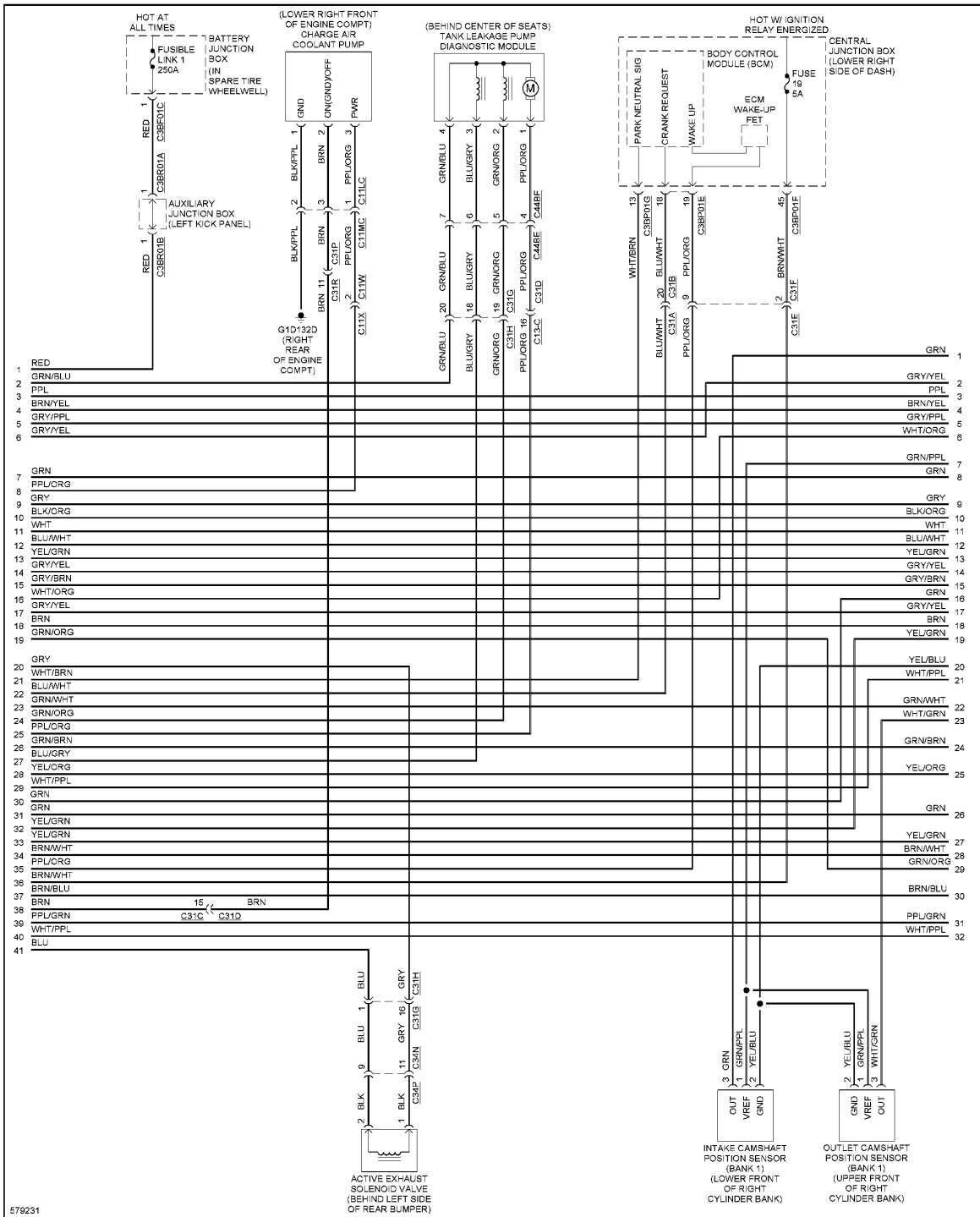
3.0L SC



**Fig. 23: 3.0L SC, Engine Performance Circuit (1 of 9)**

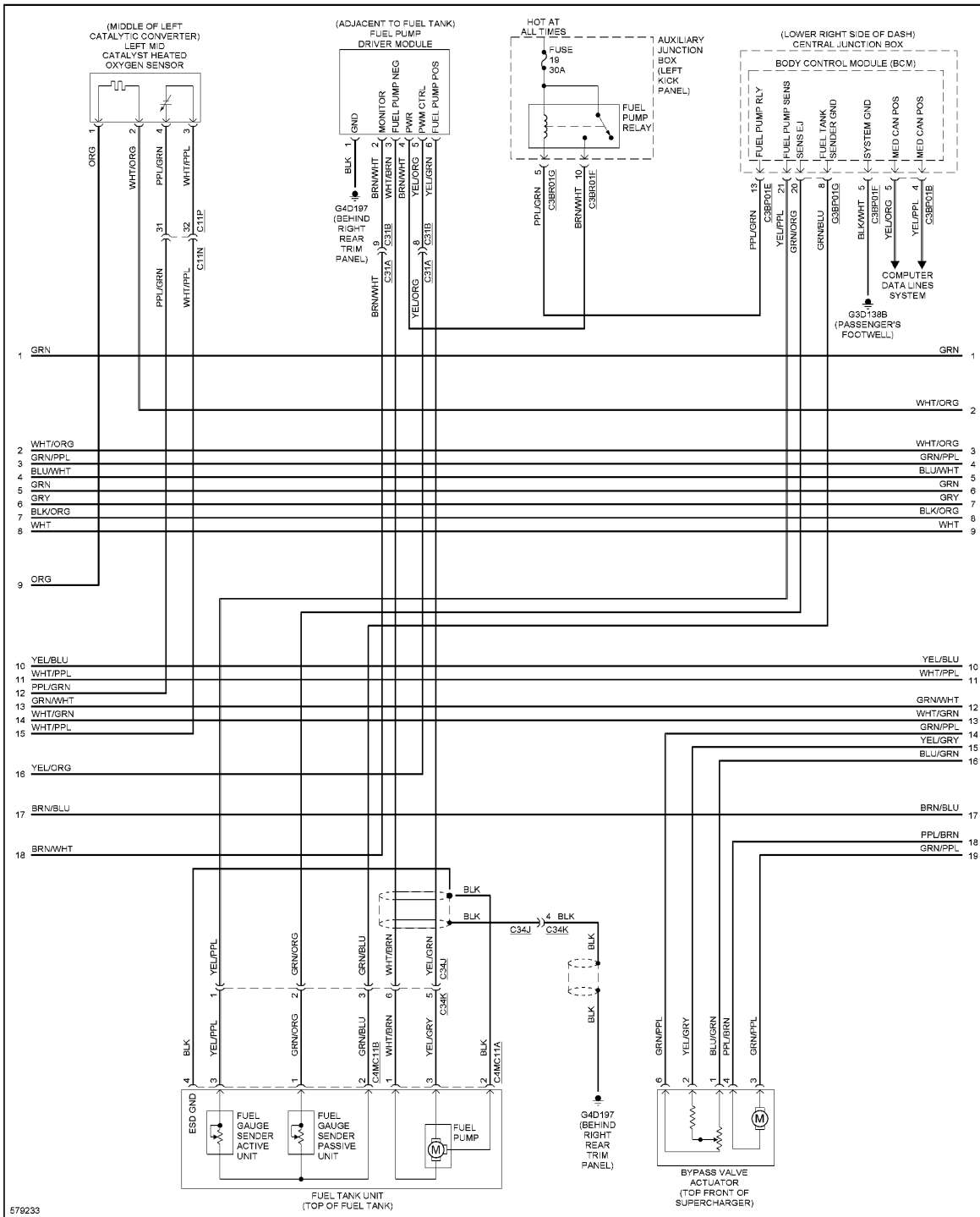


**Fig. 24: 3.0L SC, Engine Performance Circuit (2 of 9)**

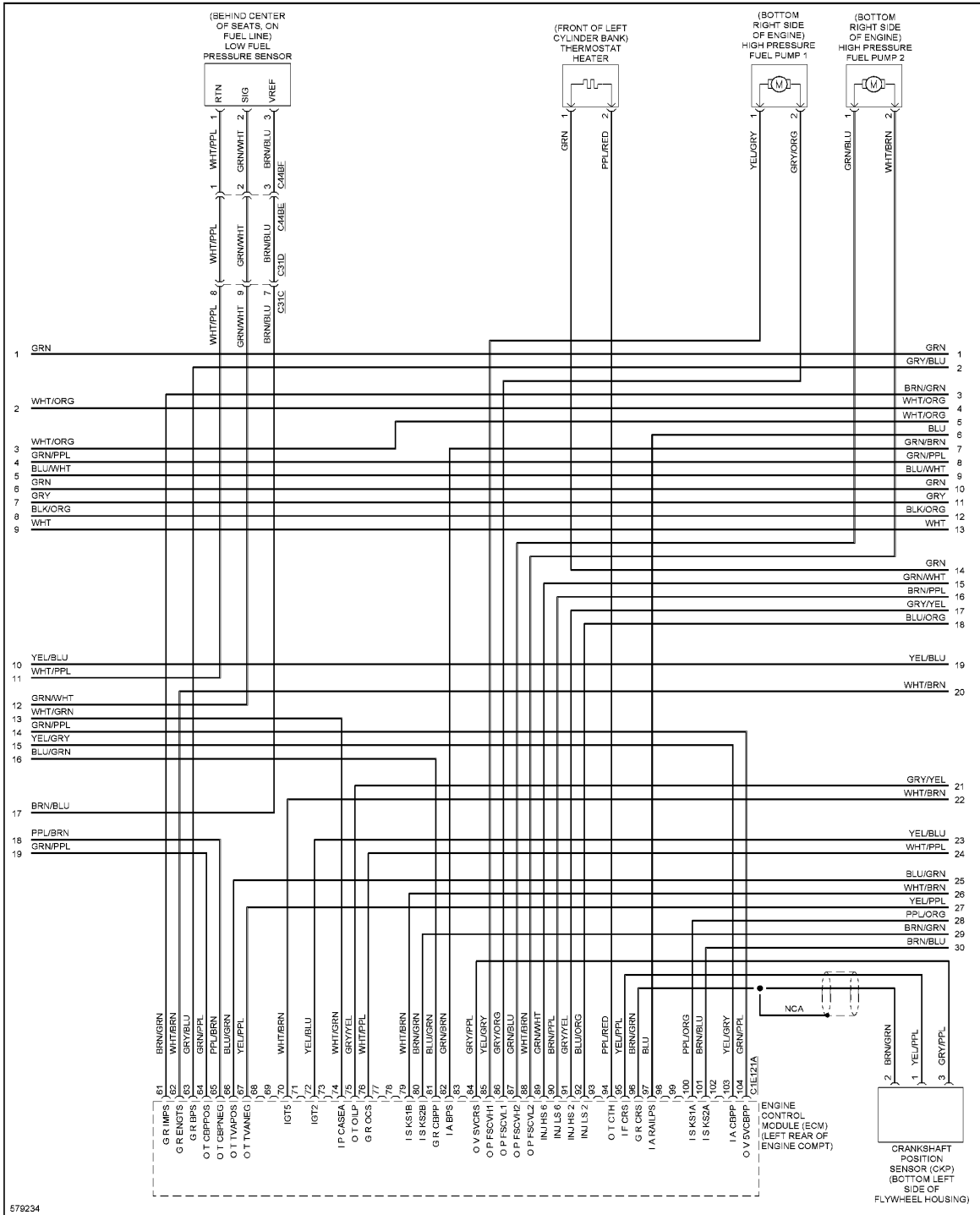


**Fig. 25: 3.0L SC, Engine Performance Circuit (3 of 9)**



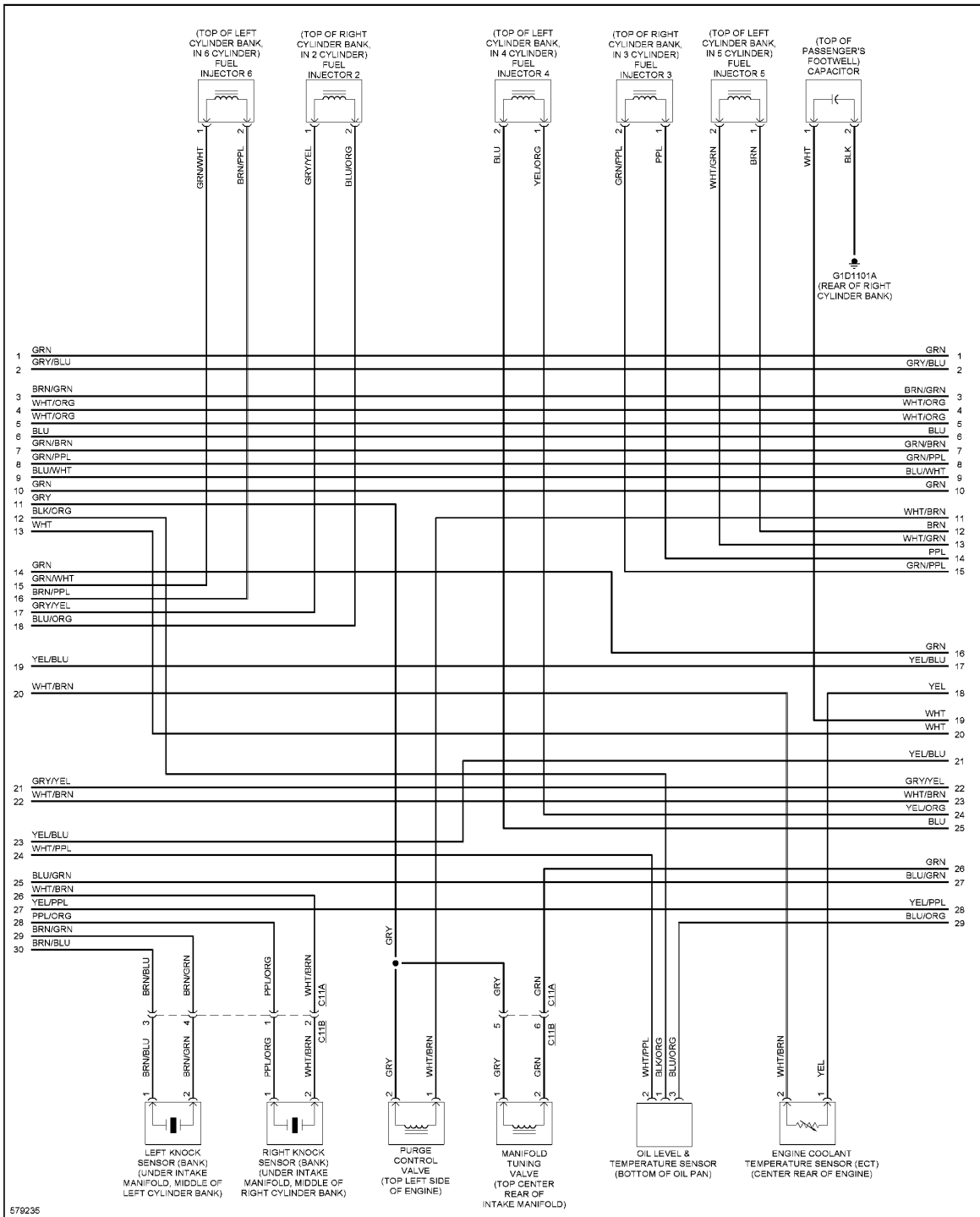


**Fig. 27: 3.0L SC, Engine Performance Circuit (5 of 9)**

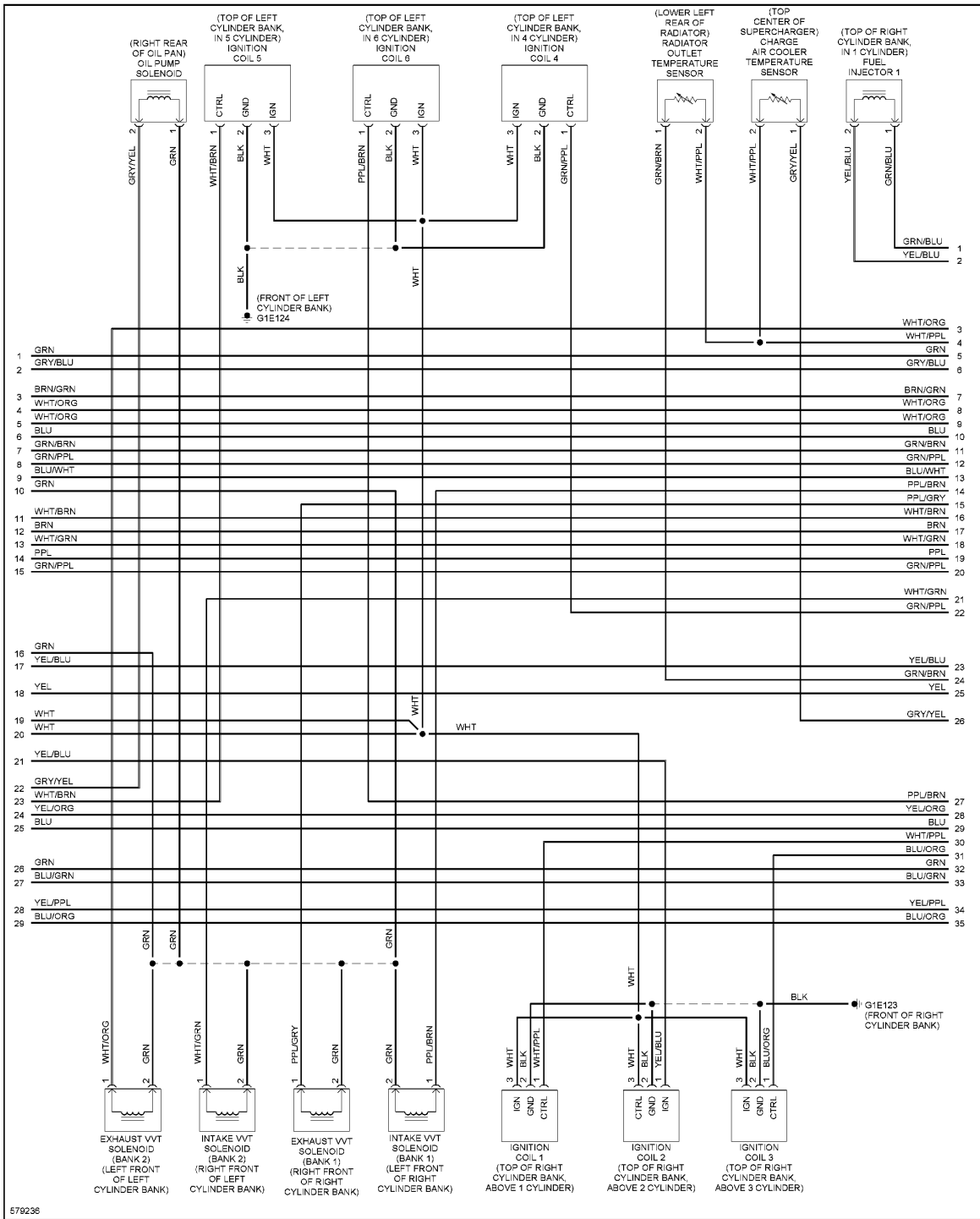


**Fig. 28: 3.0L SC, Engine Performance Circuit (6 of 9)**

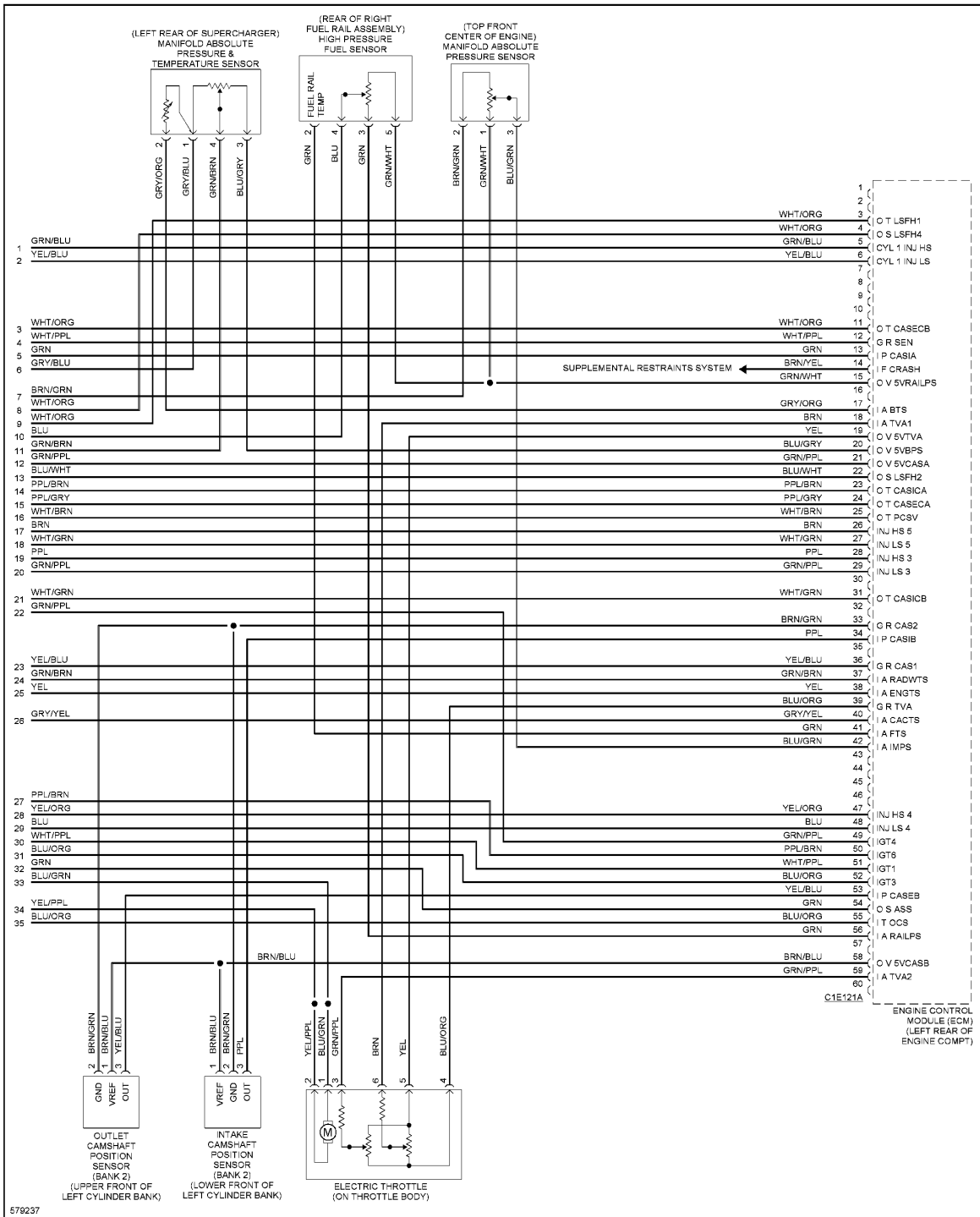




**Fig. 29: 3.0L SC, Engine Performance Circuit (7 of 9)**

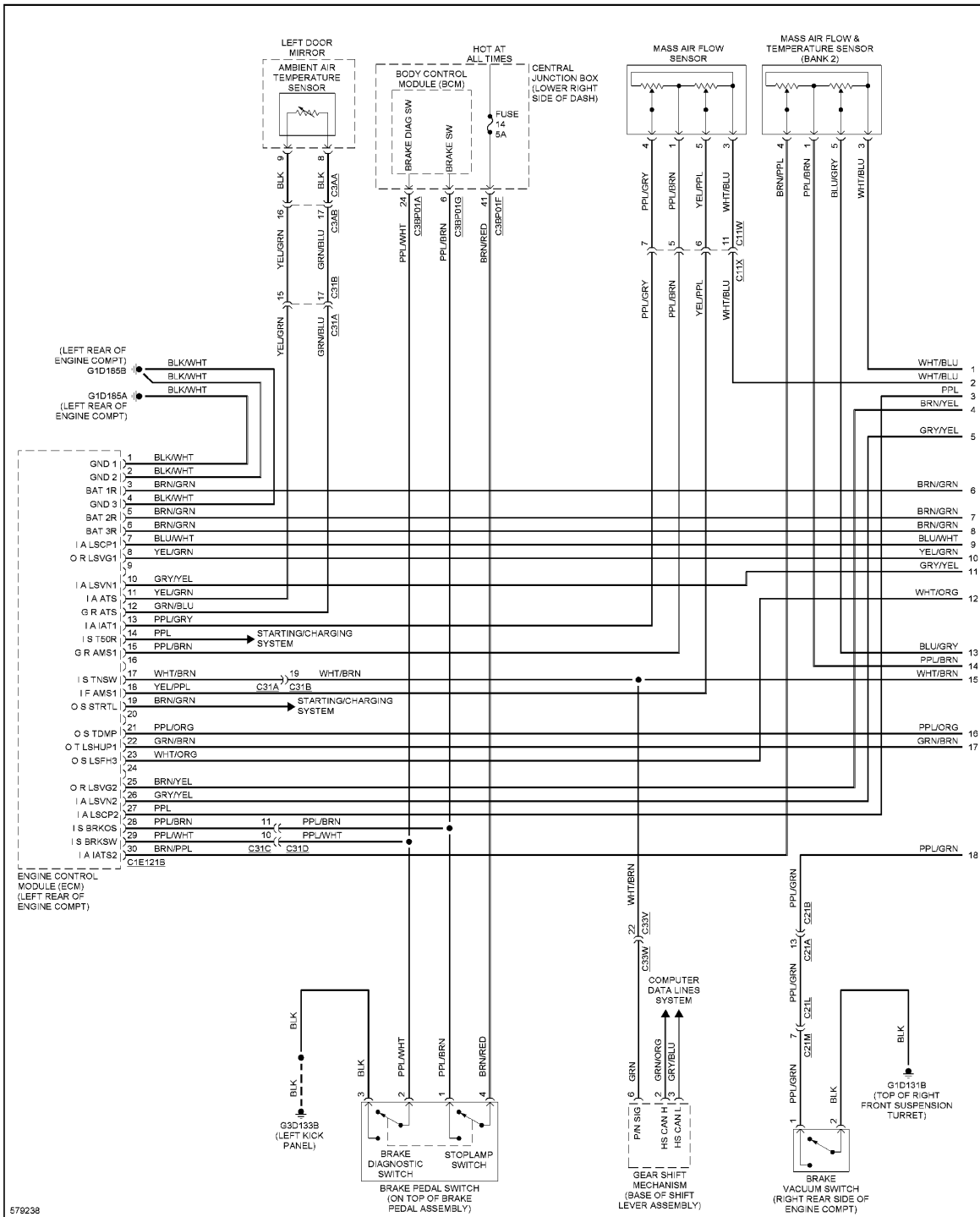


**Fig. 30: 3.0L SC, Engine Performance Circuit (8 of 9)**



**Fig. 31: 3.0L SC, Engine Performance Circuit (9 of 9)**

**5.0L SC**



**Fig. 32: 5.0L SC, Engine Performance Circuit (1 of 9)**

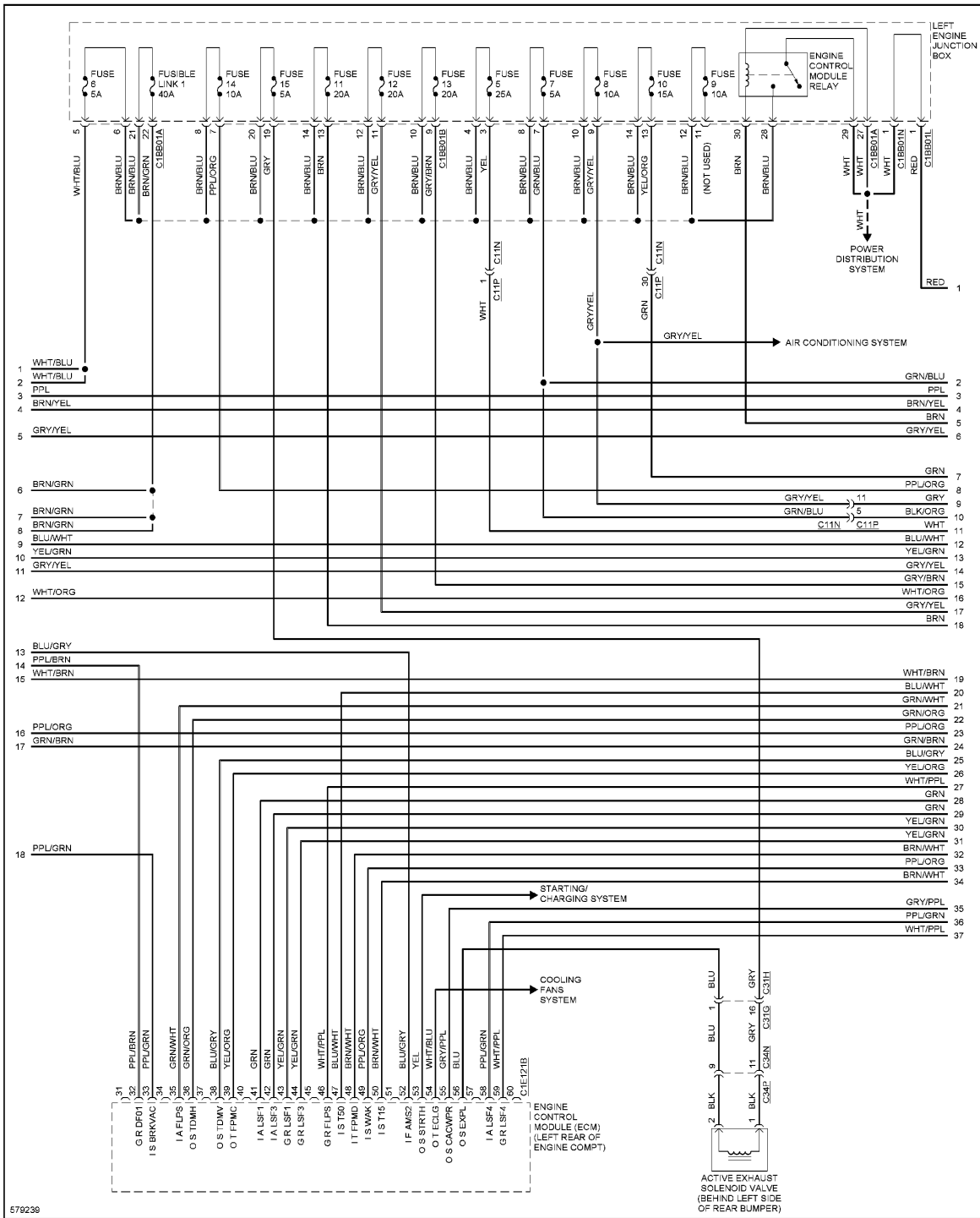


Fig. 33: 5.0L SC, Engine Performance Circuit (2 of 9)

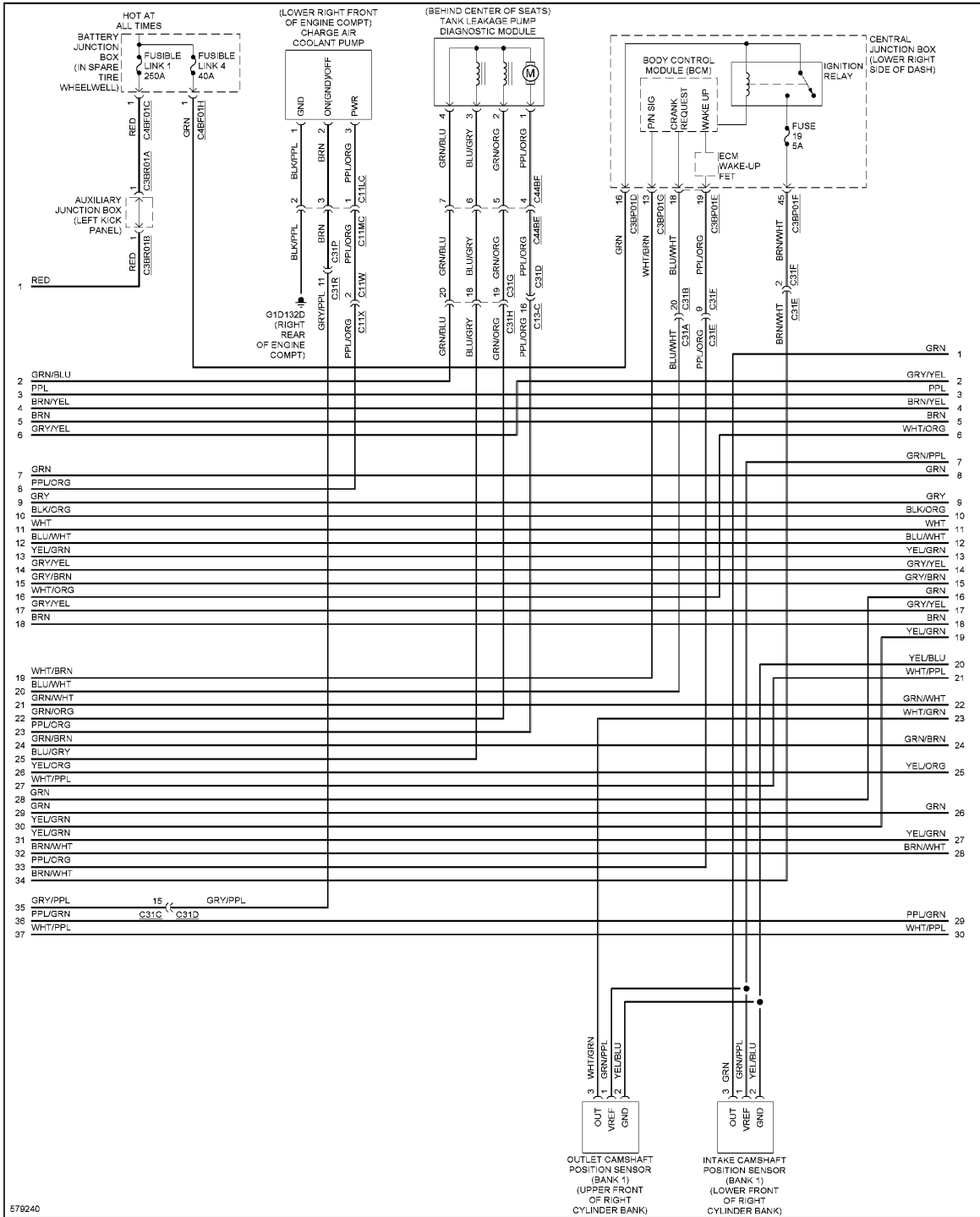
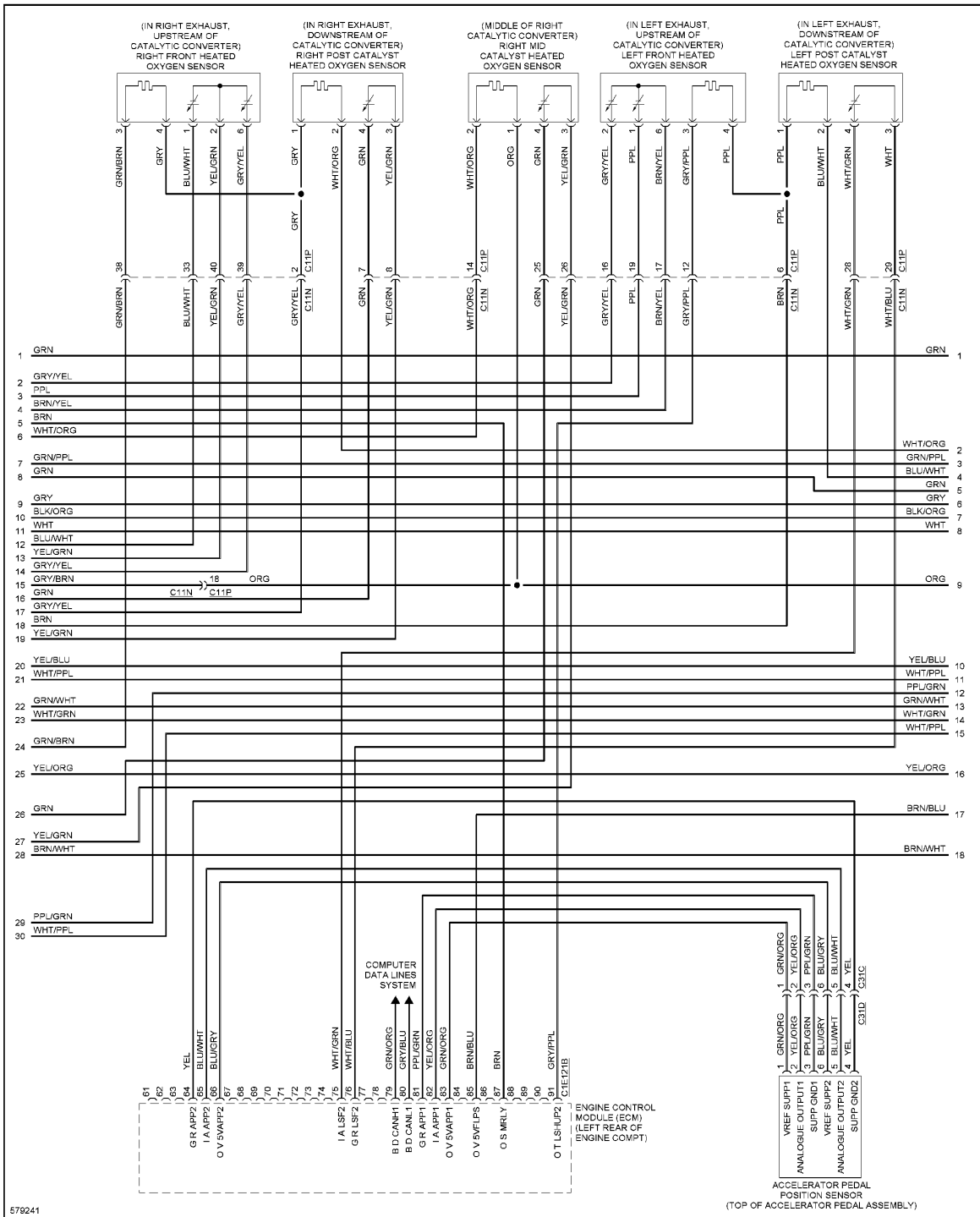
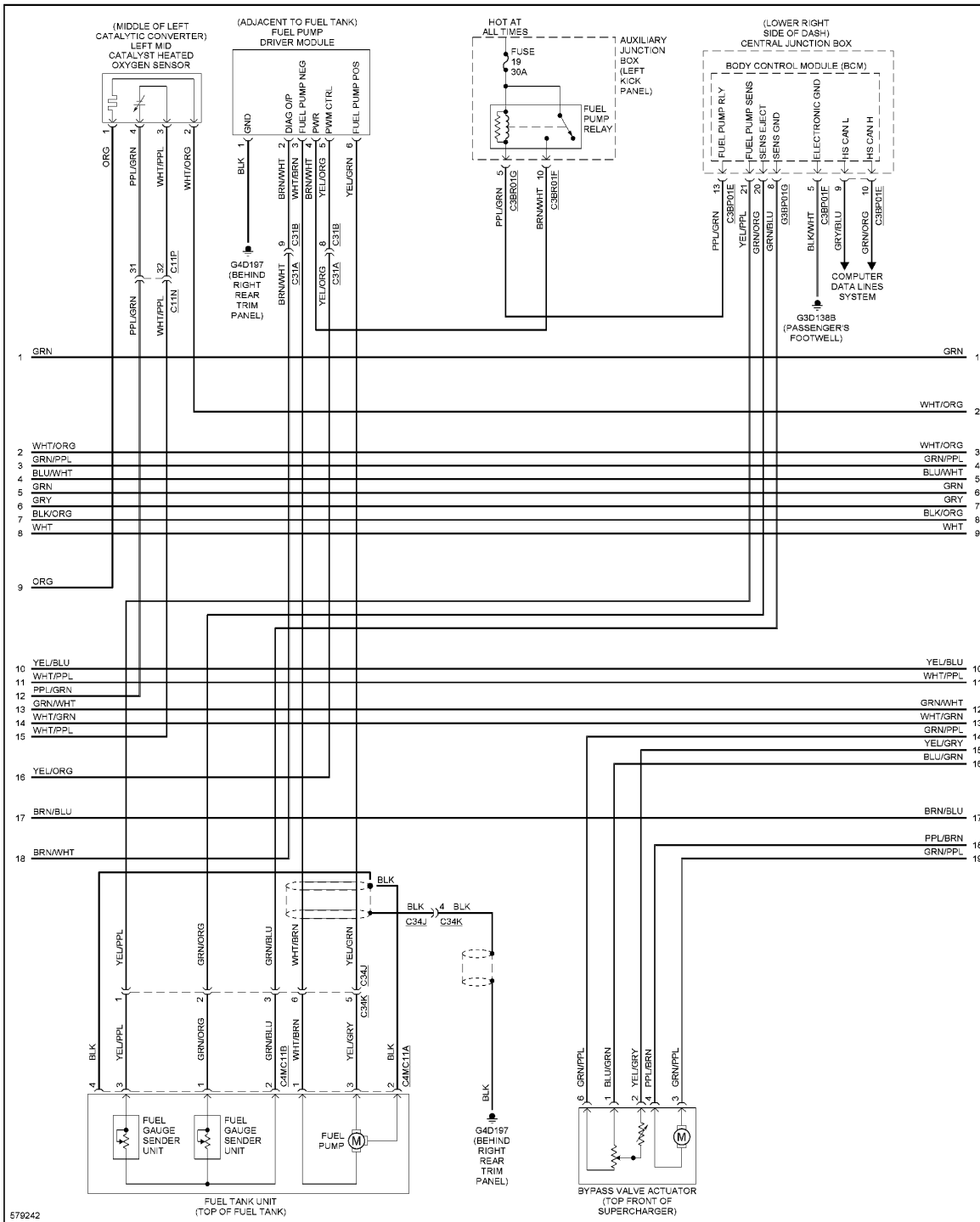


Fig. 34: 5.0L SC, Engine Performance Circuit (3 of 9)

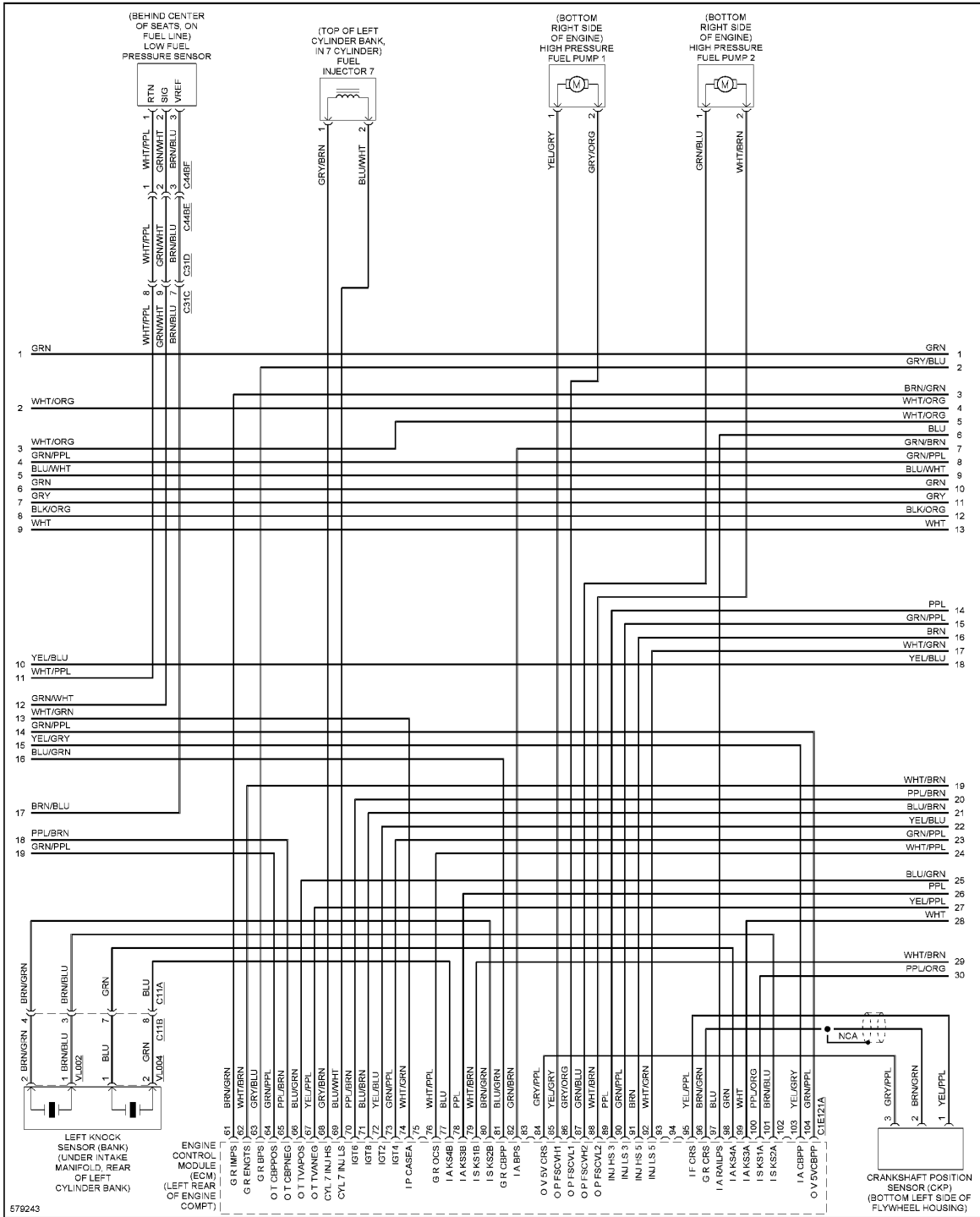


**Fig. 35: 5.0L SC, Engine Performance Circuit (4 of 9)**

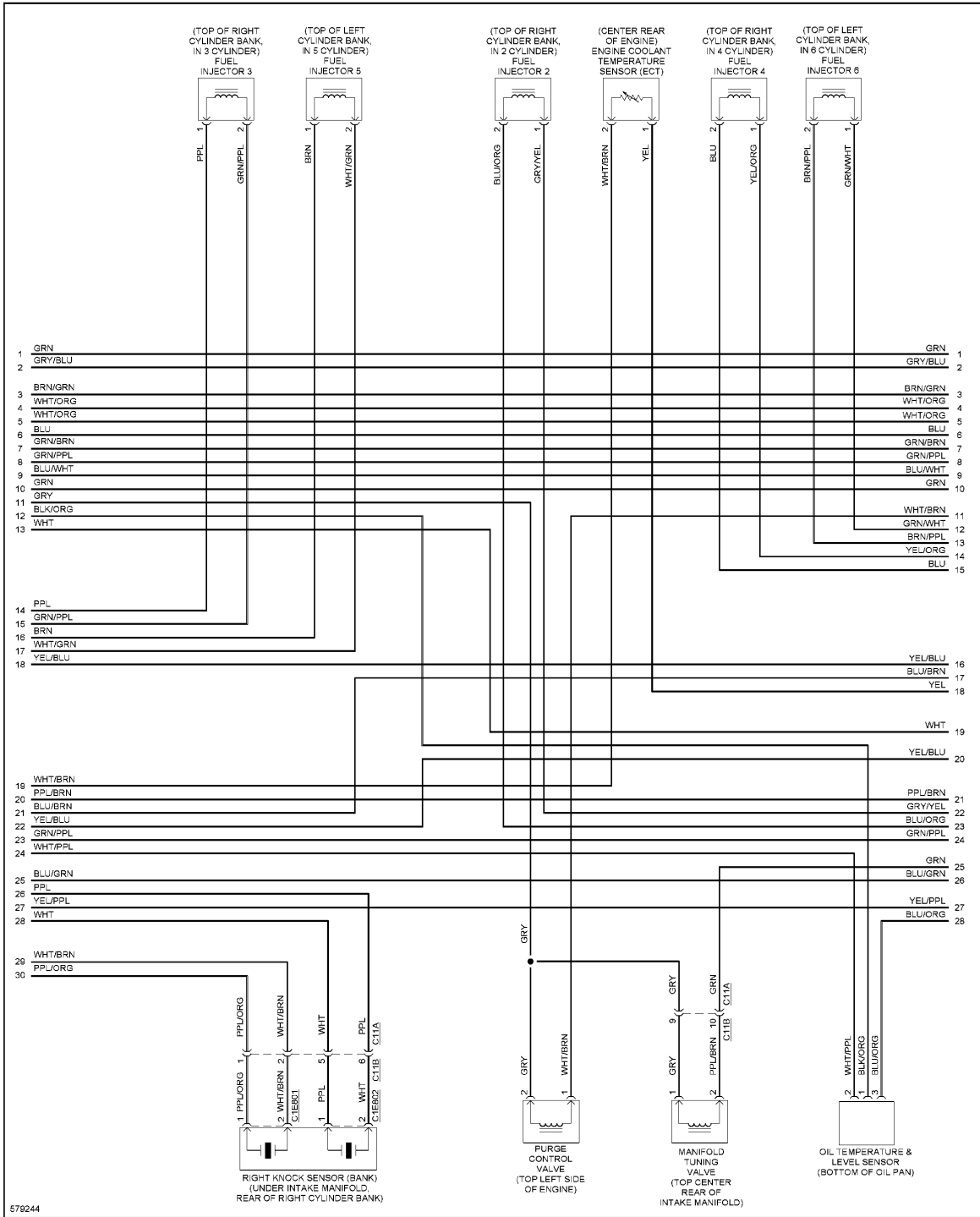


**Fig. 36: 5.0L SC, Engine Performance Circuit (5 of 9)**

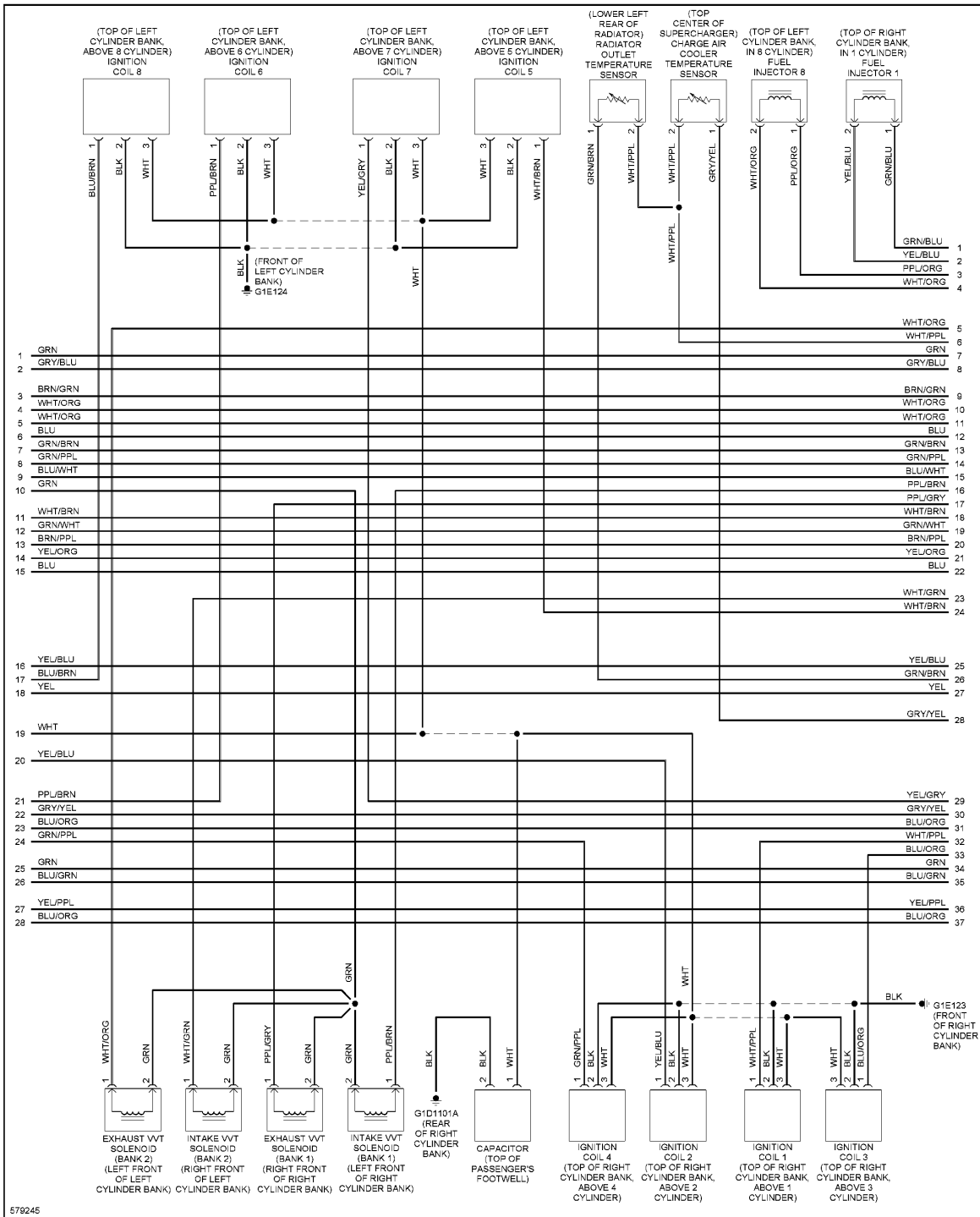




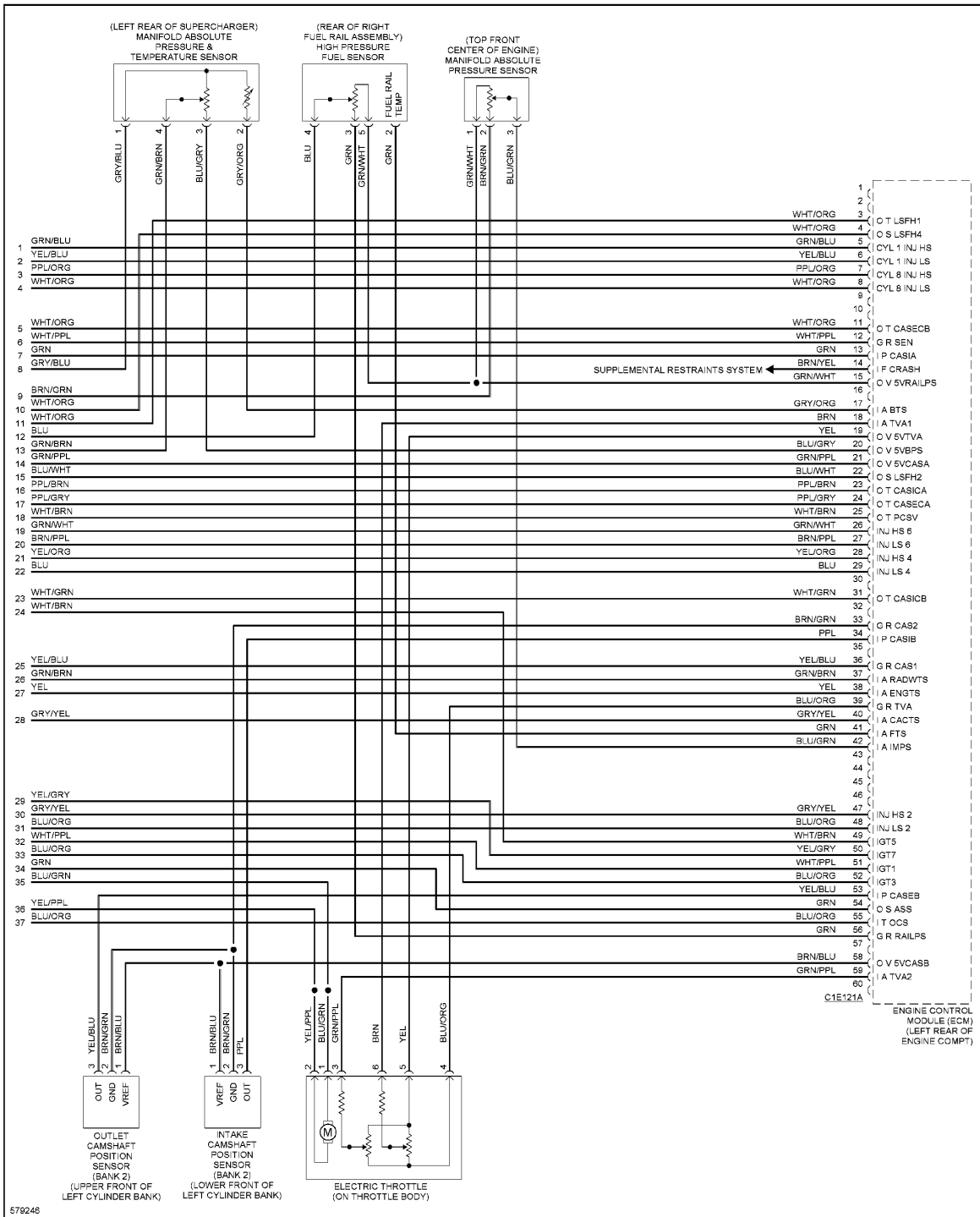
**Fig. 37: 5.0L SC, Engine Performance Circuit (6 of 9)**



**Fig. 38: 5.0L SC, Engine Performance Circuit (7 of 9)**

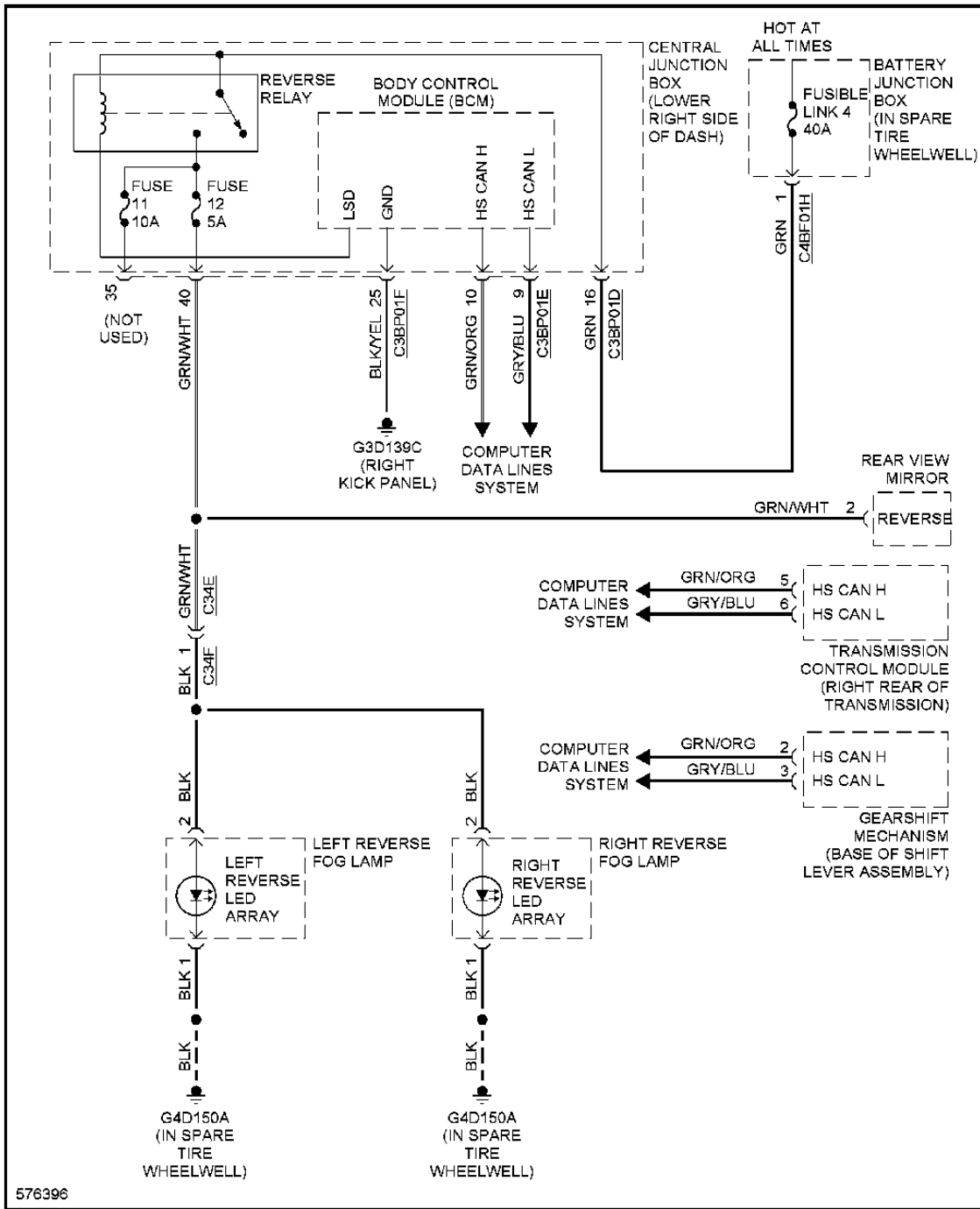


**Fig. 39: 5.0L SC, Engine Performance Circuit (8 of 9)**



**Fig. 40: 5.0L SC, Engine Performance Circuit (9 of 9)**

## EXTERIOR LIGHTS



**Fig. 41: Backup Lamps Circuit**

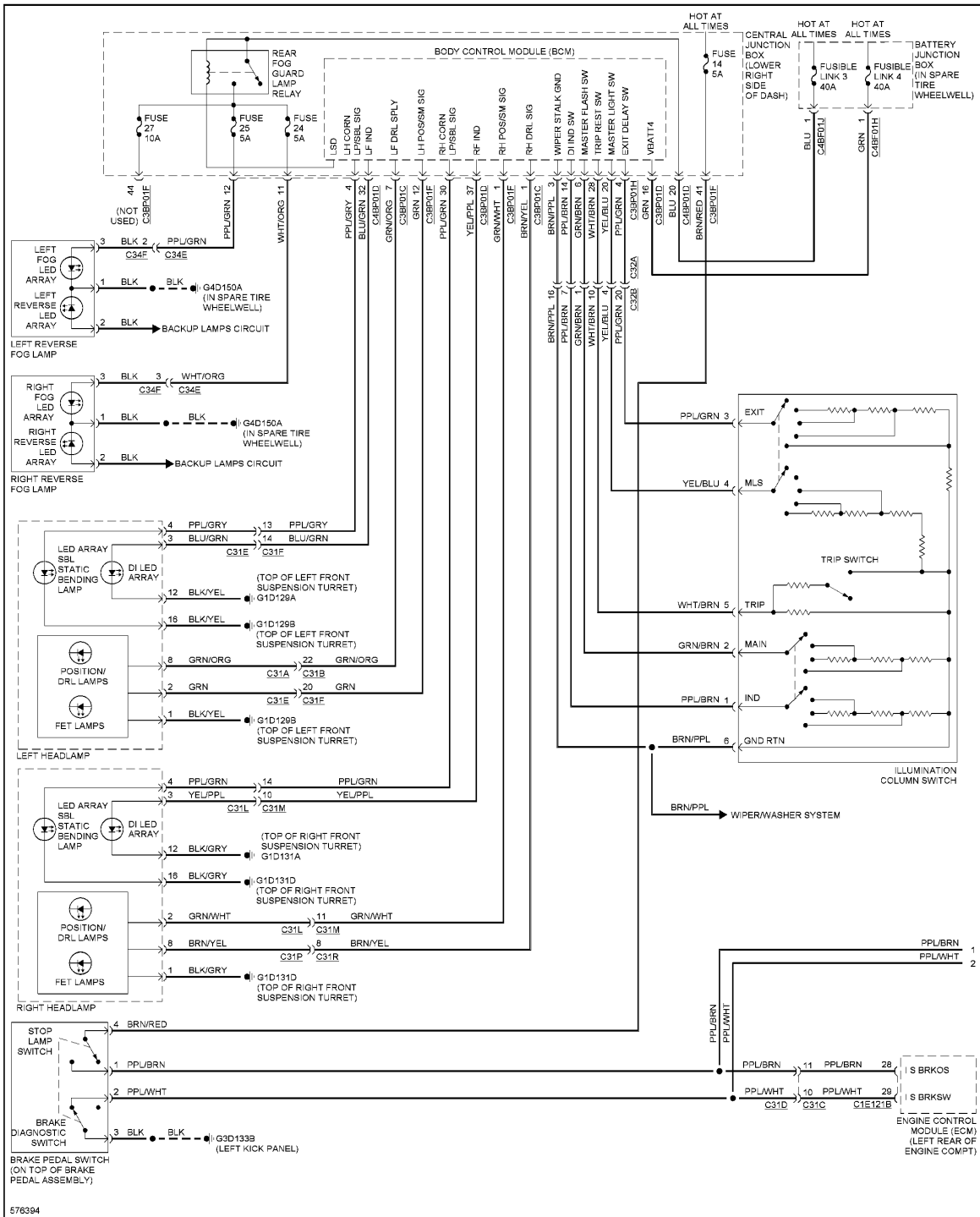
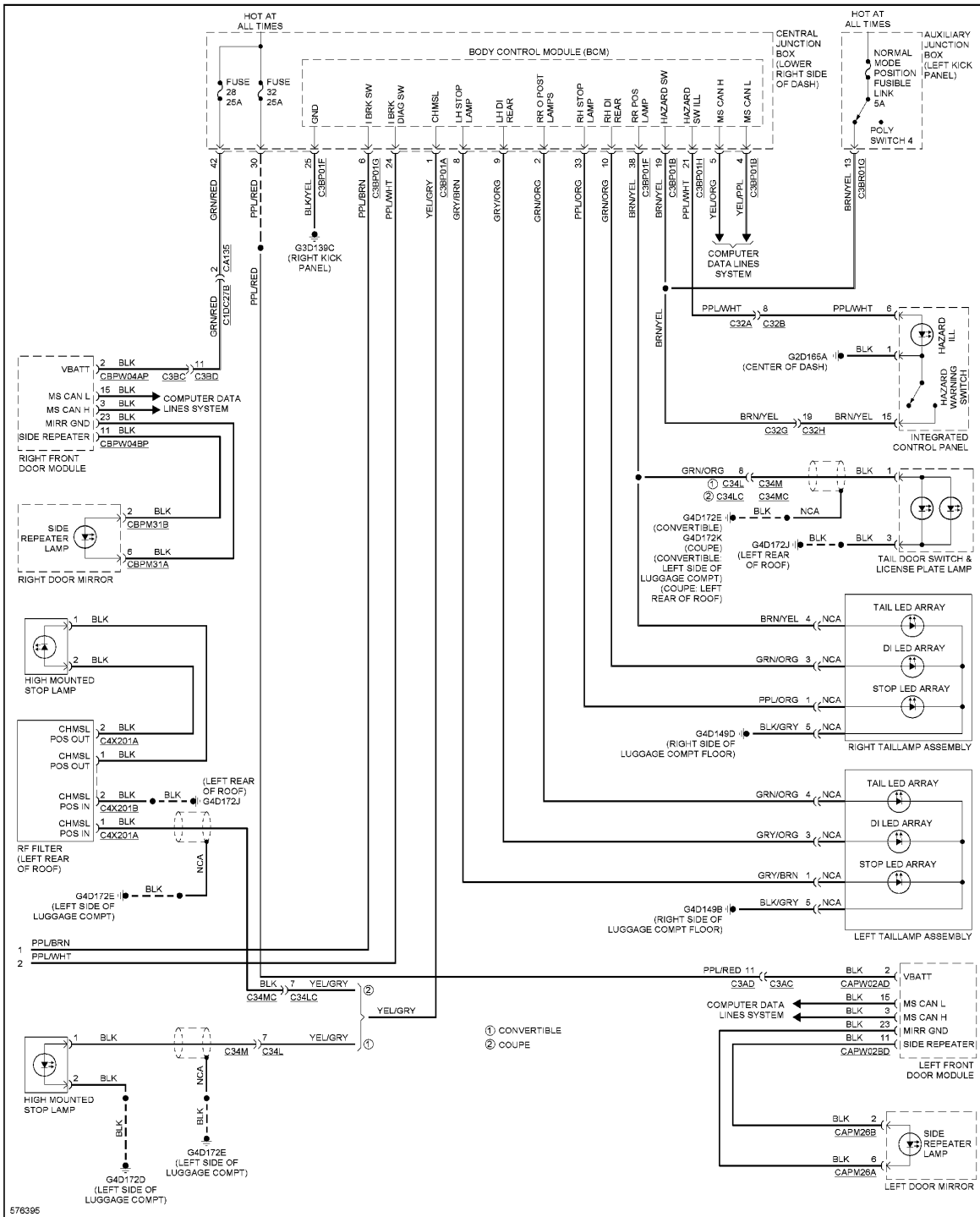
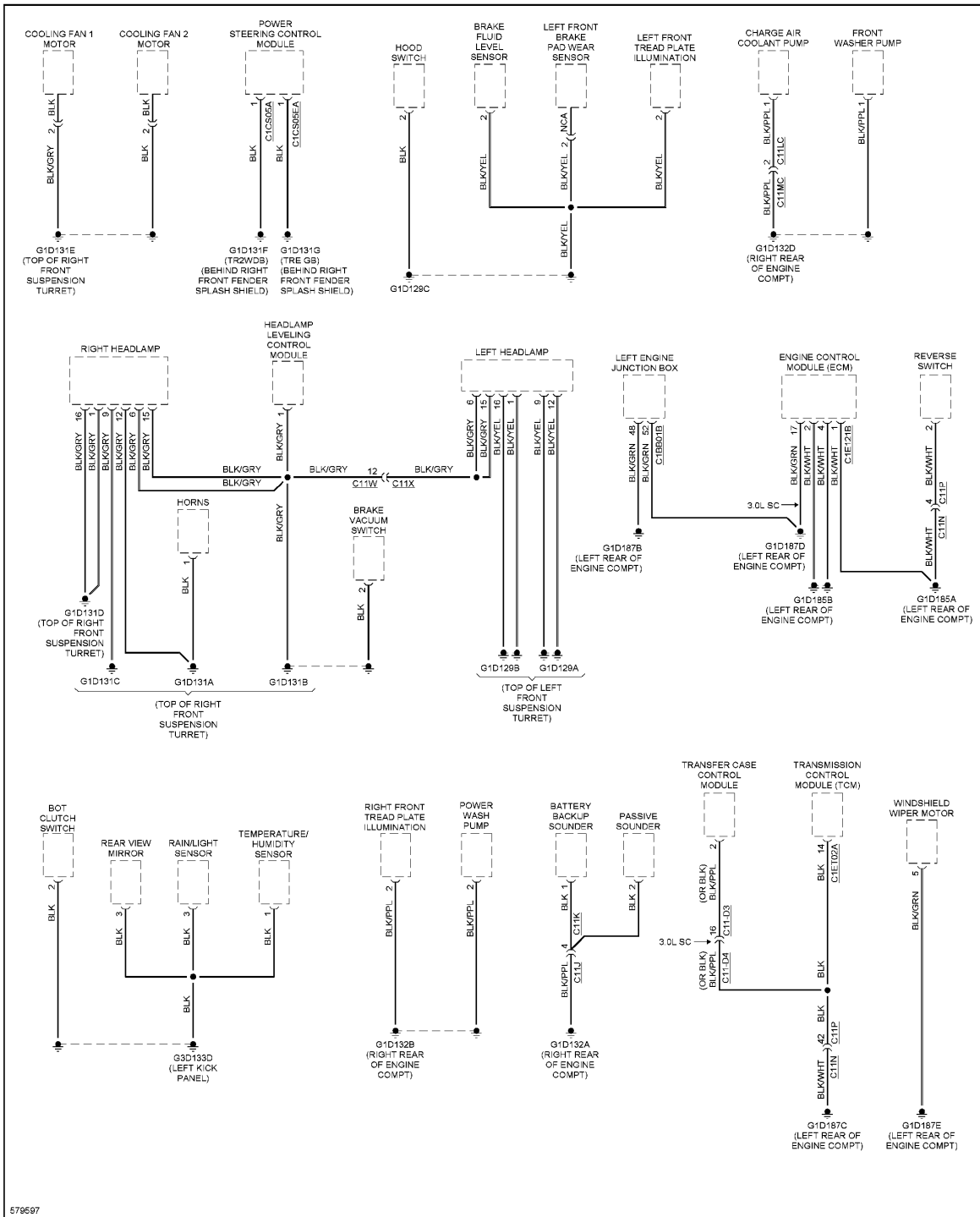


Fig. 42: Exterior Lamps Circuit (1 of 2)



**Fig. 43: Exterior Lamps Circuit (2 of 2)**

**GROUND DISTRIBUTION**



**Fig. 44: Ground Distribution Circuit (1 of 6)**



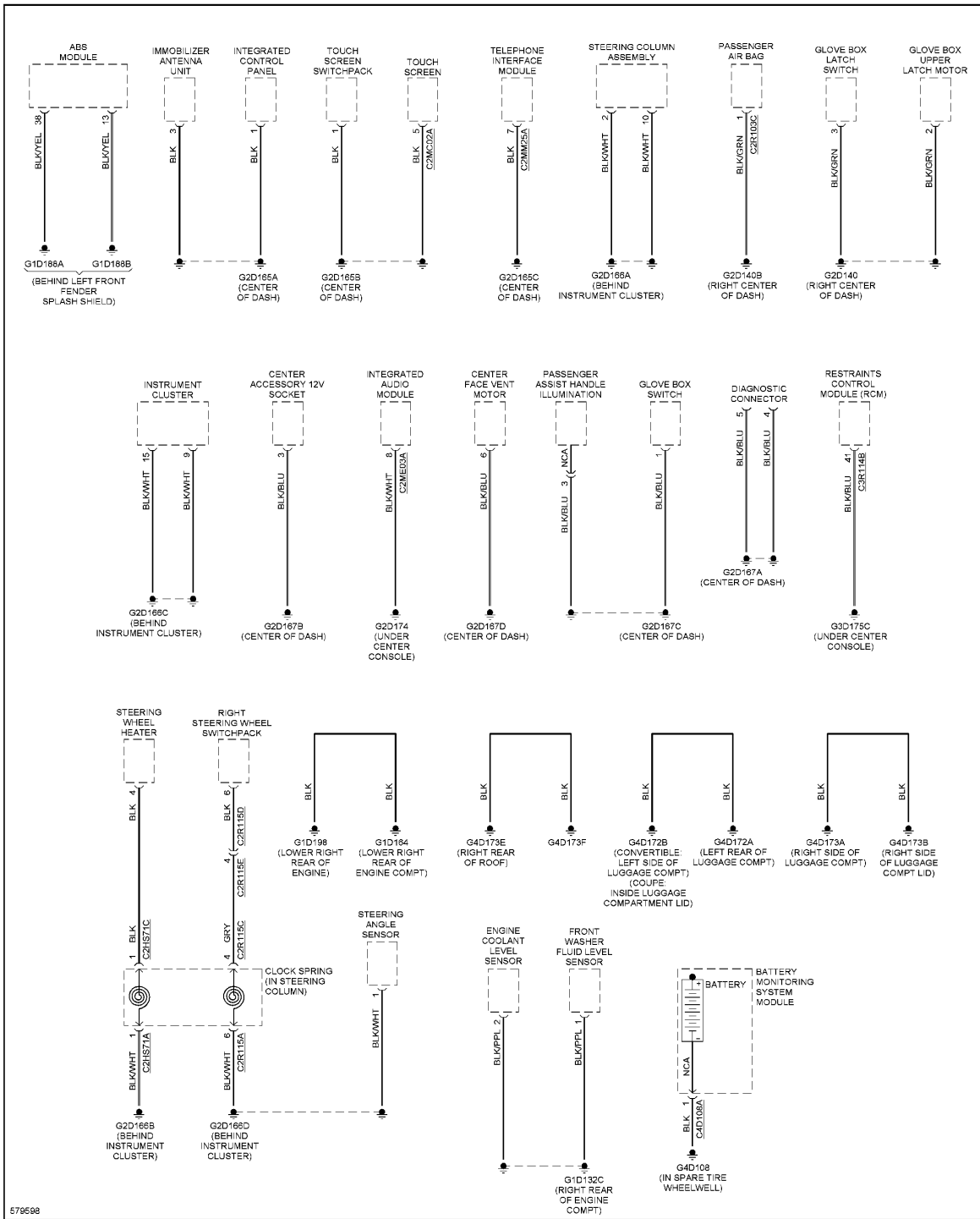


Fig. 45: Ground Distribution Circuit (2 of 6)

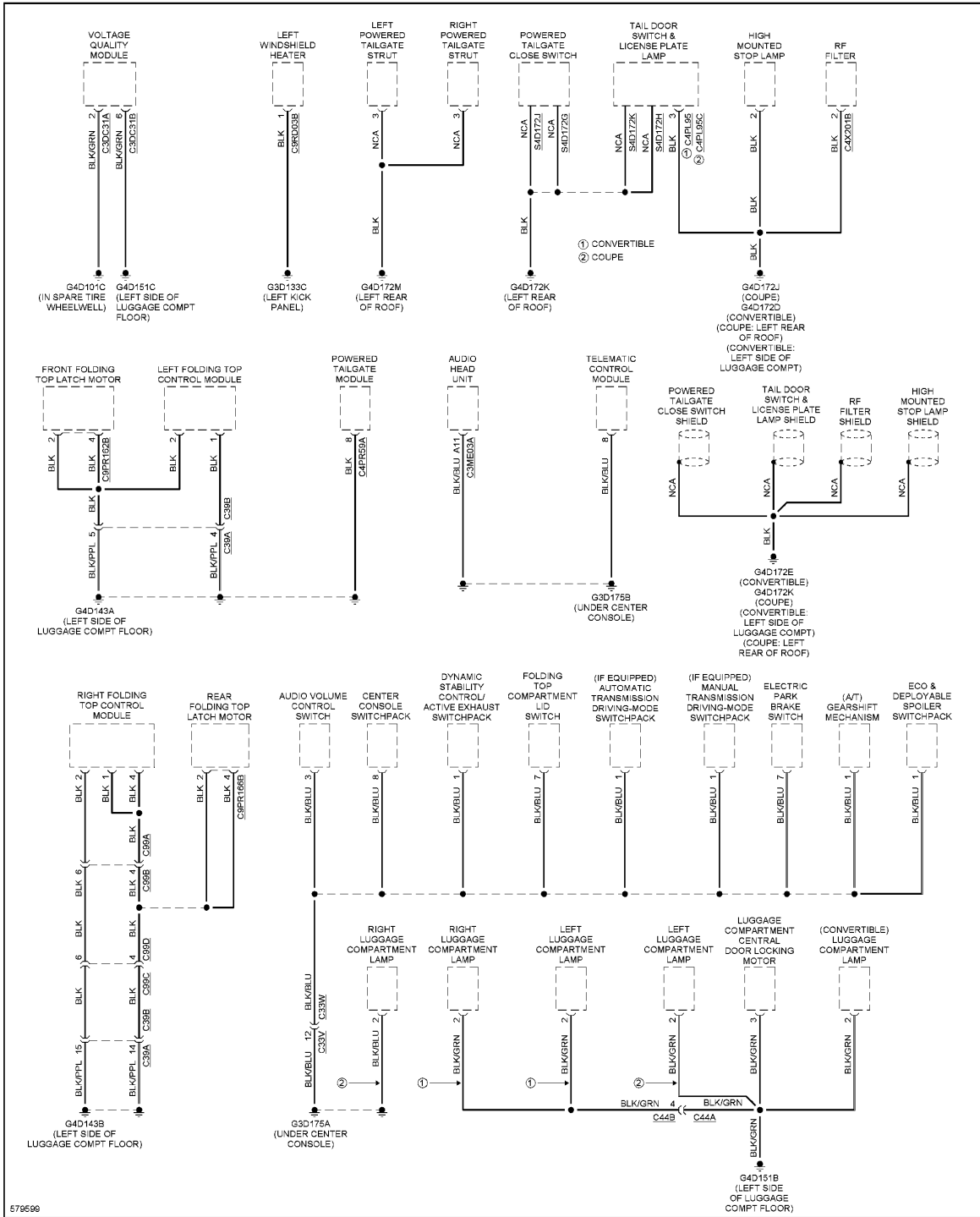
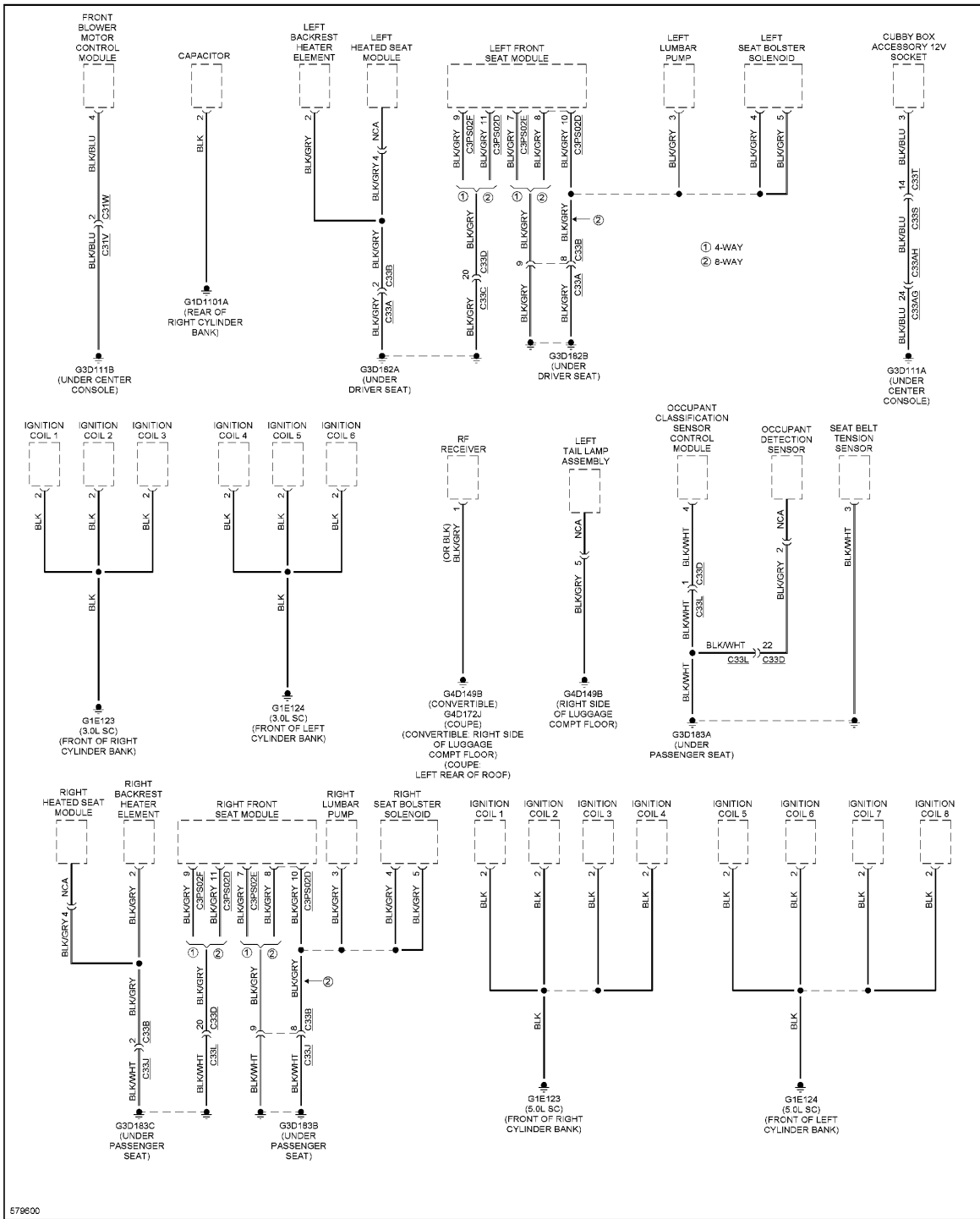
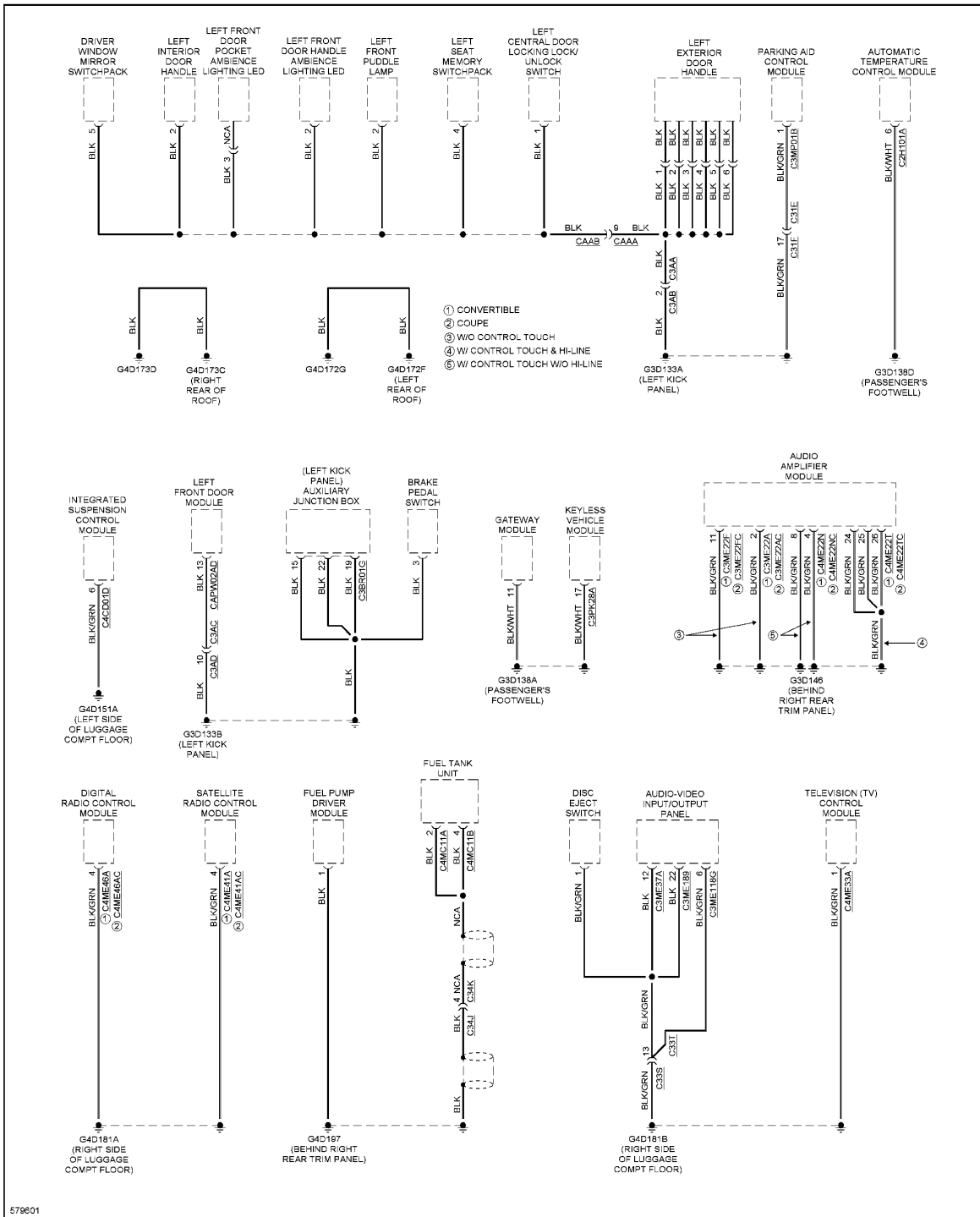


Fig. 46: Ground Distribution Circuit (3 of 6)



**Fig. 47: Ground Distribution Circuit (4 of 6)**



**Fig. 48: Ground Distribution Circuit (5 of 6)**

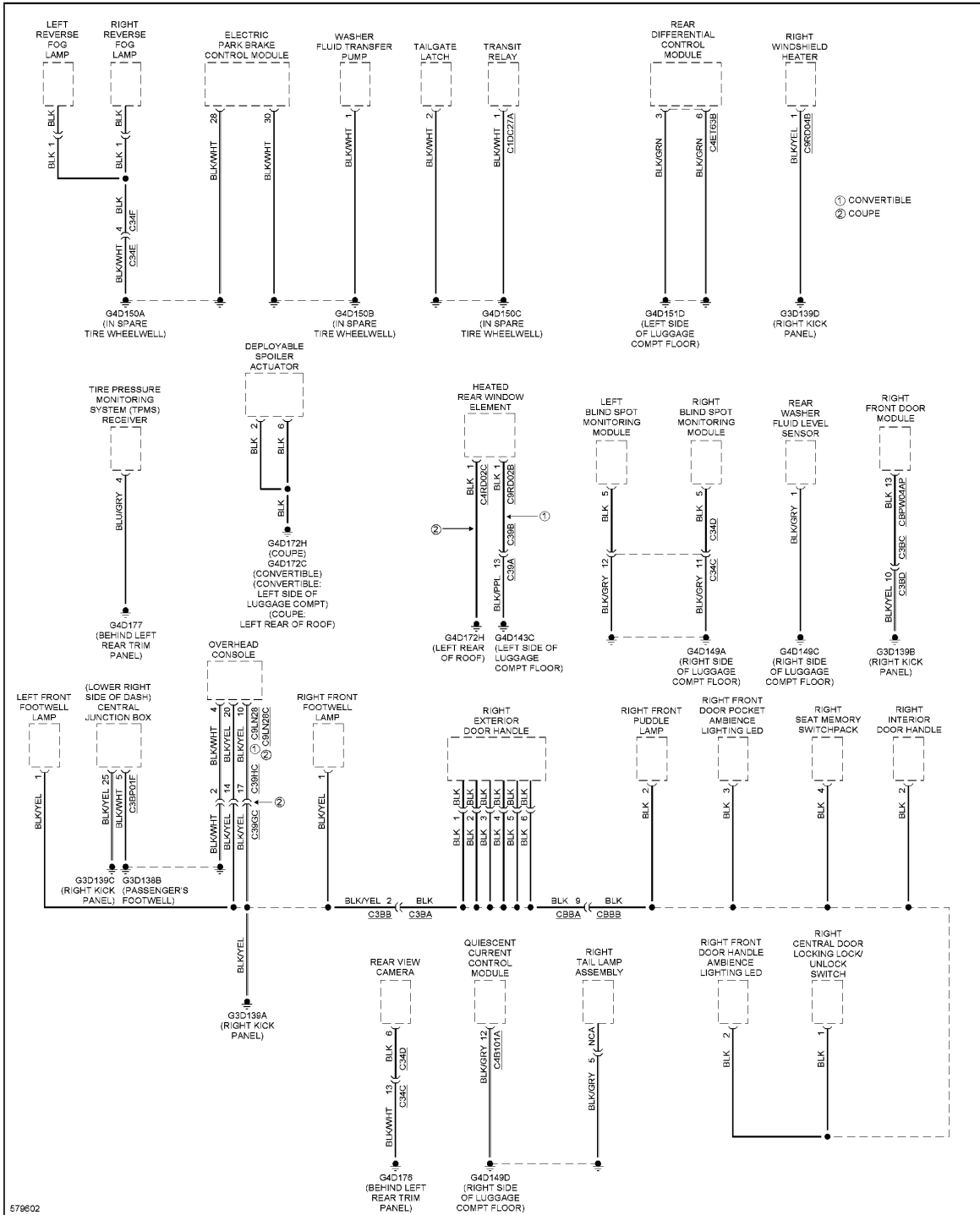
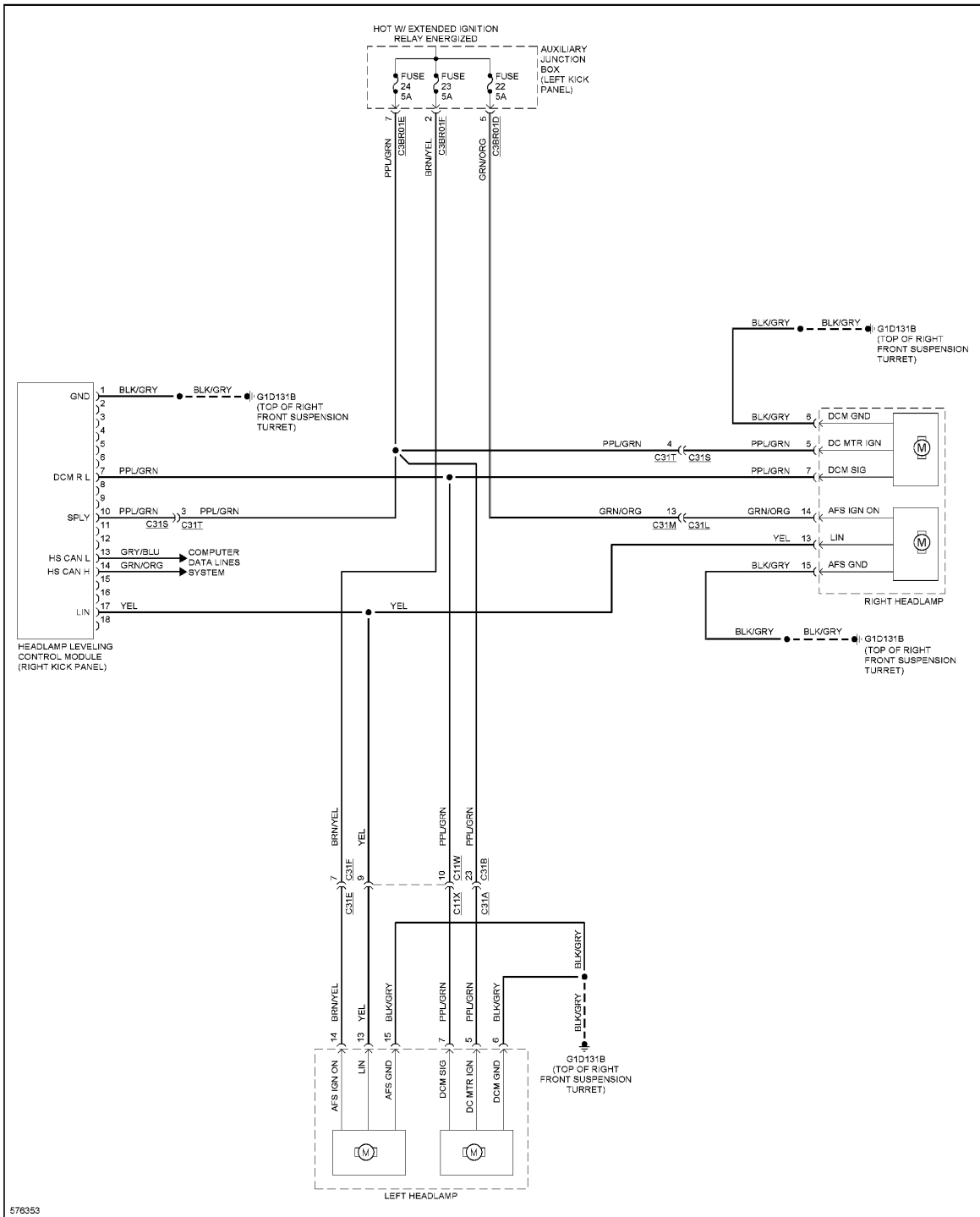
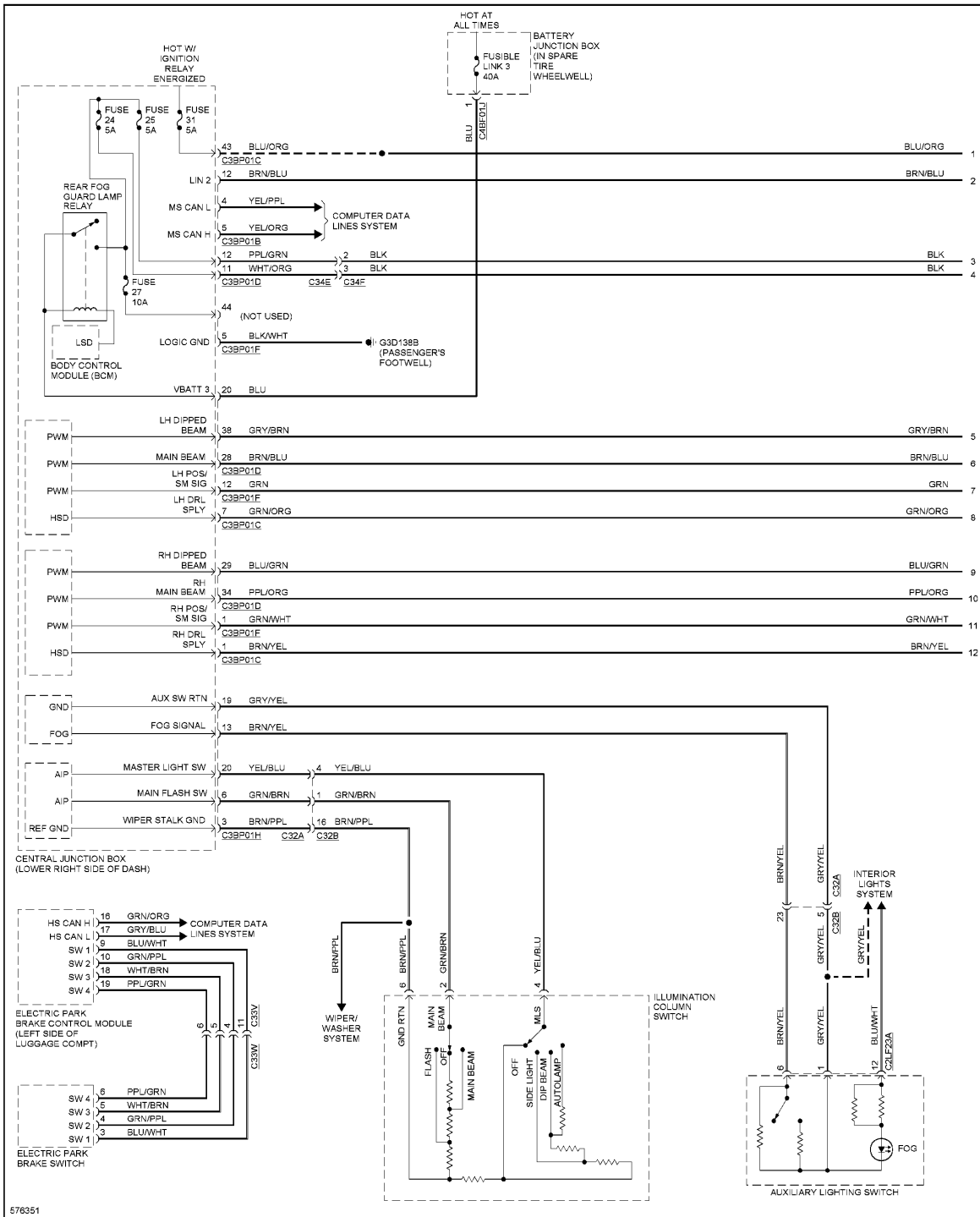


Fig. 49: Ground Distribution Circuit (6 of 6)

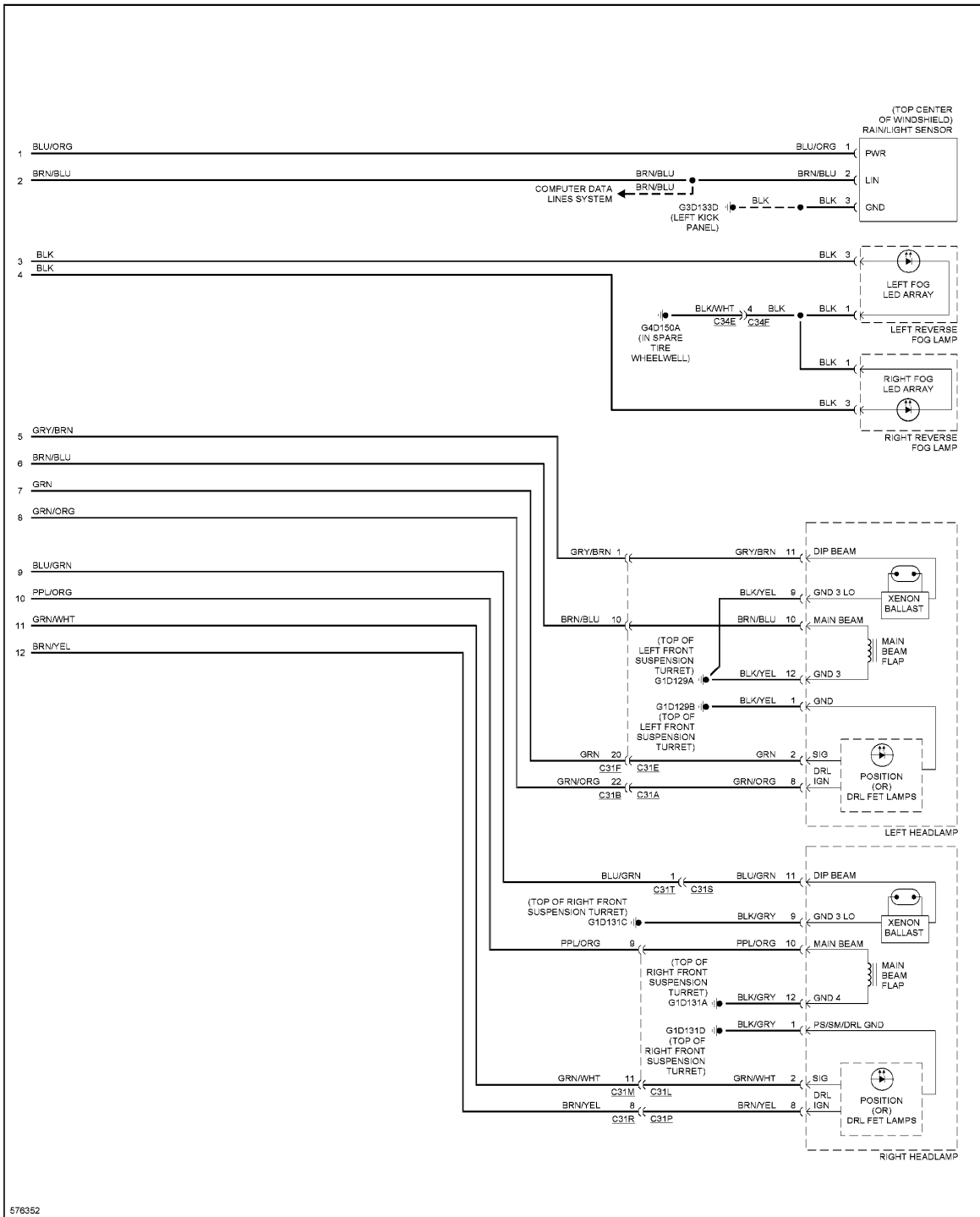
## HEADLIGHTS



**Fig. 50: Adaptive Front Lighting Circuit**



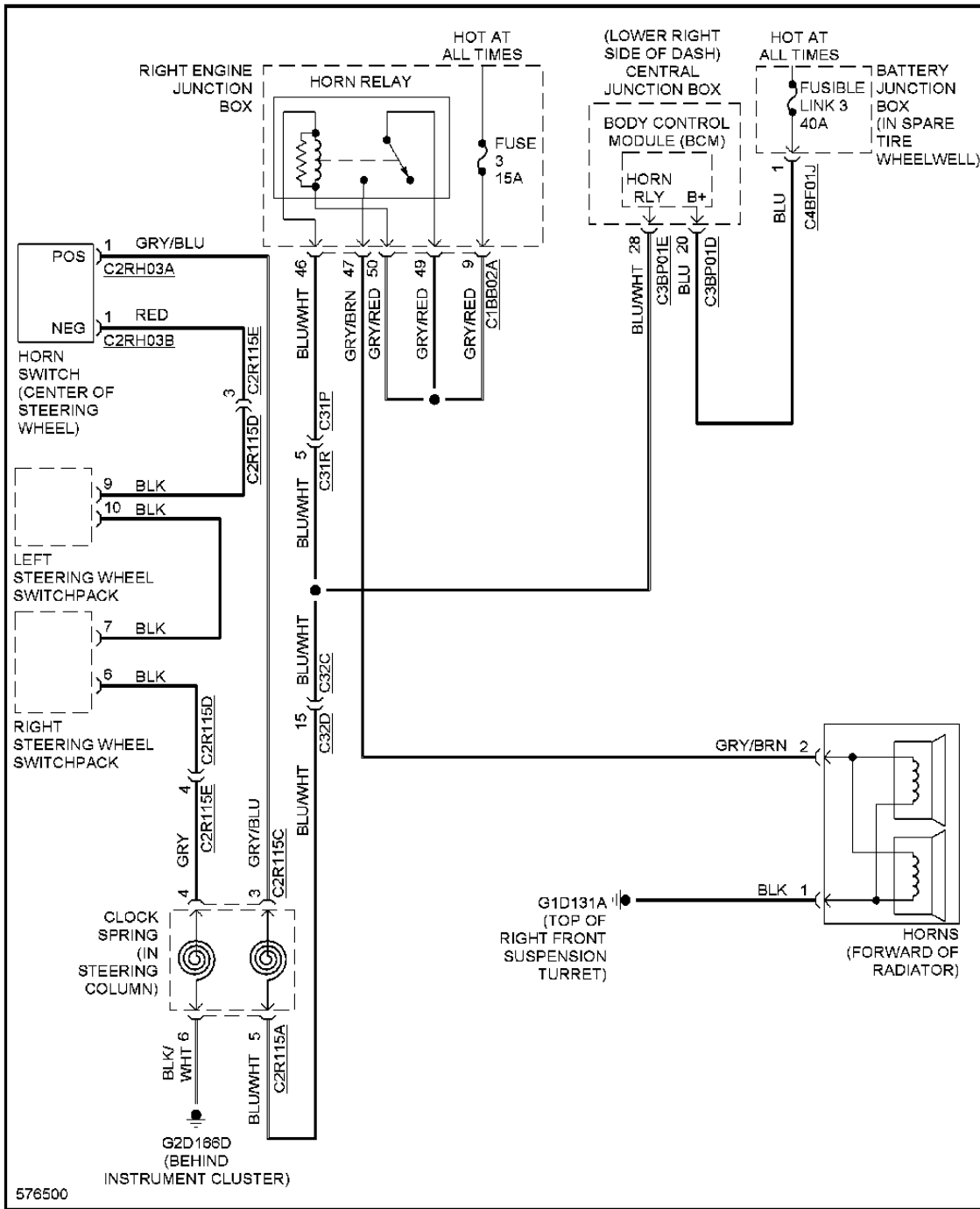
**Fig. 51: Headlamps Circuit (1 of 2)**



**Fig. 52: Headlamps Circuit (2 of 2)**

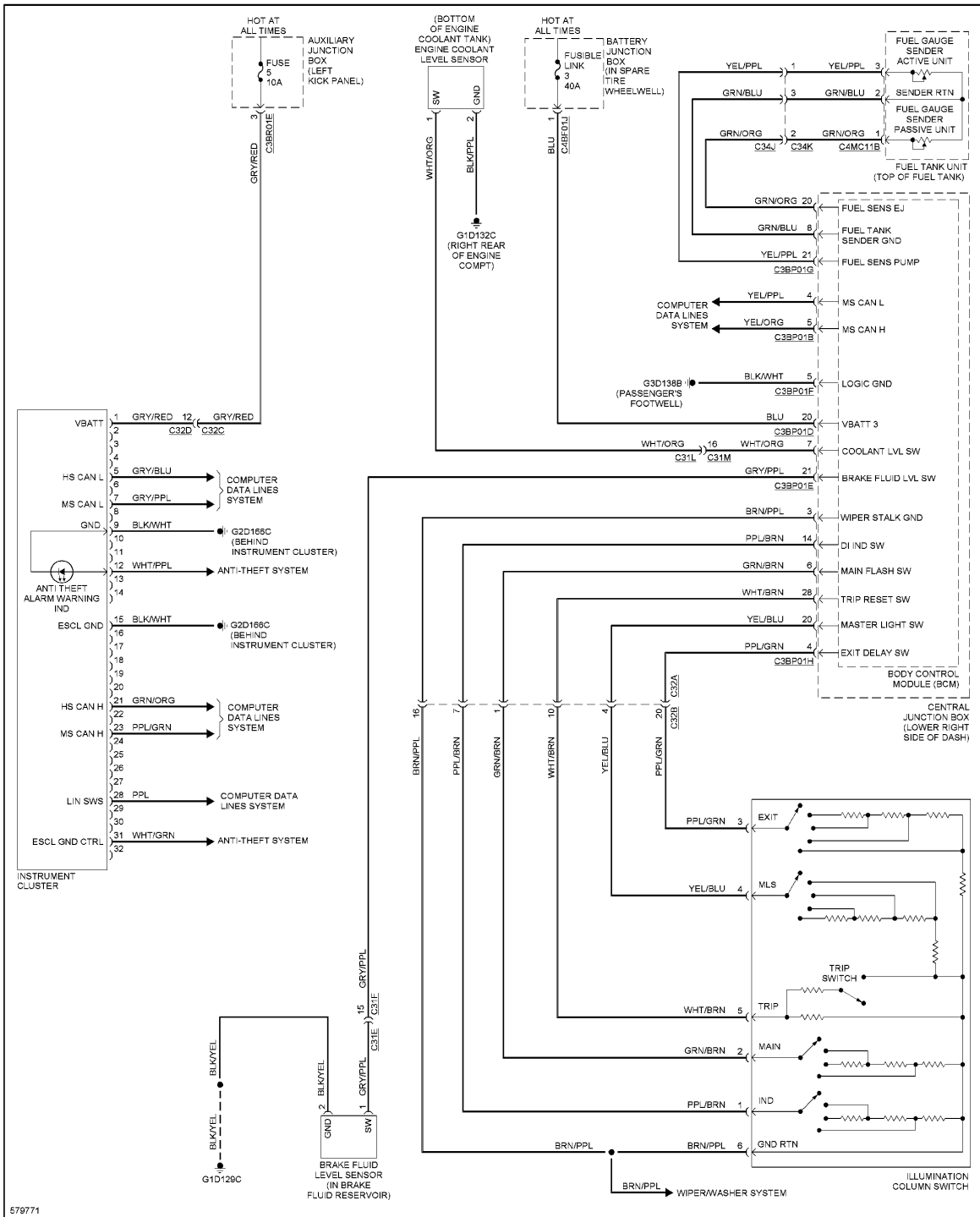
**HORN**





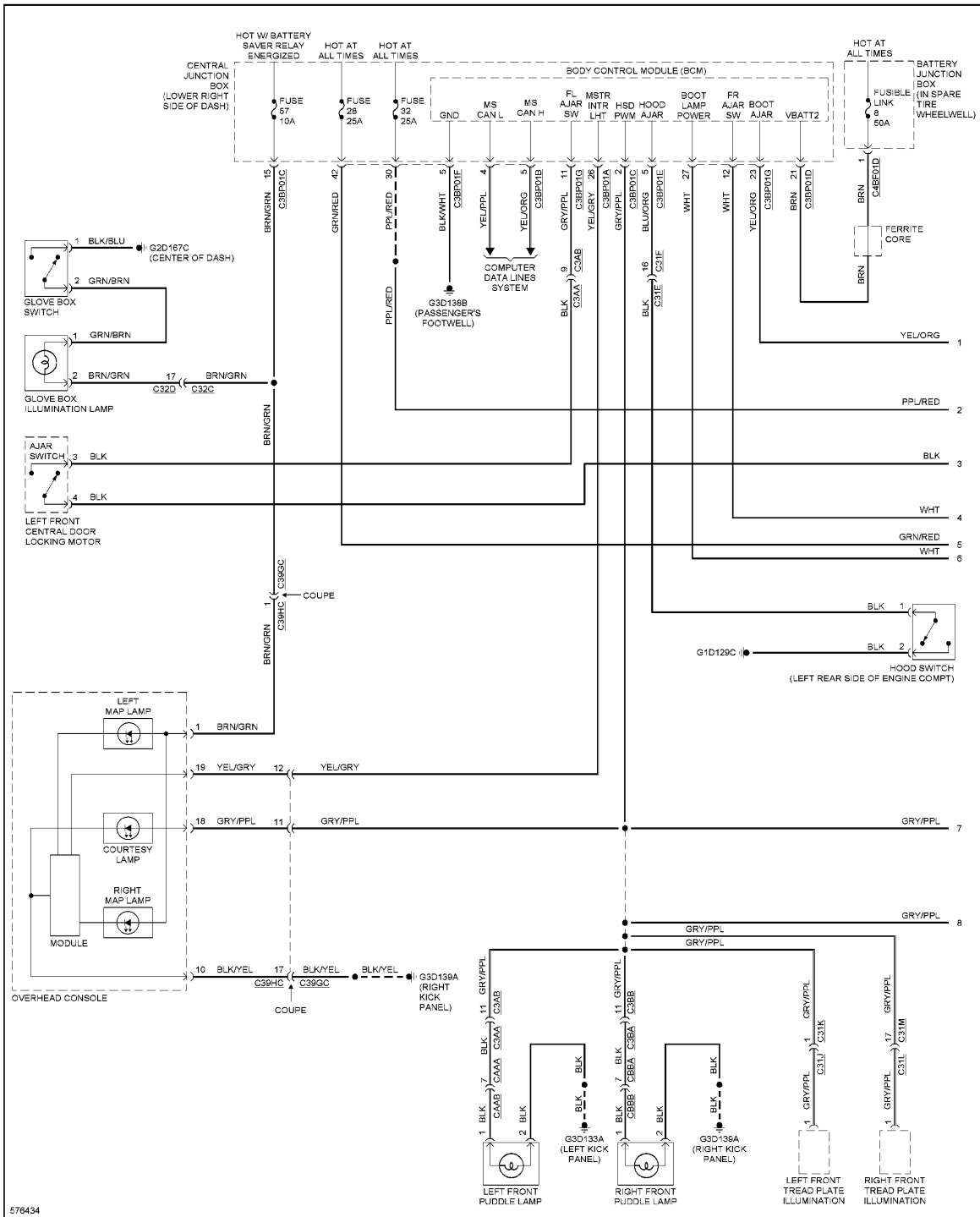
**Fig. 53: Horn Circuit**

**INSTRUMENT CLUSTER**

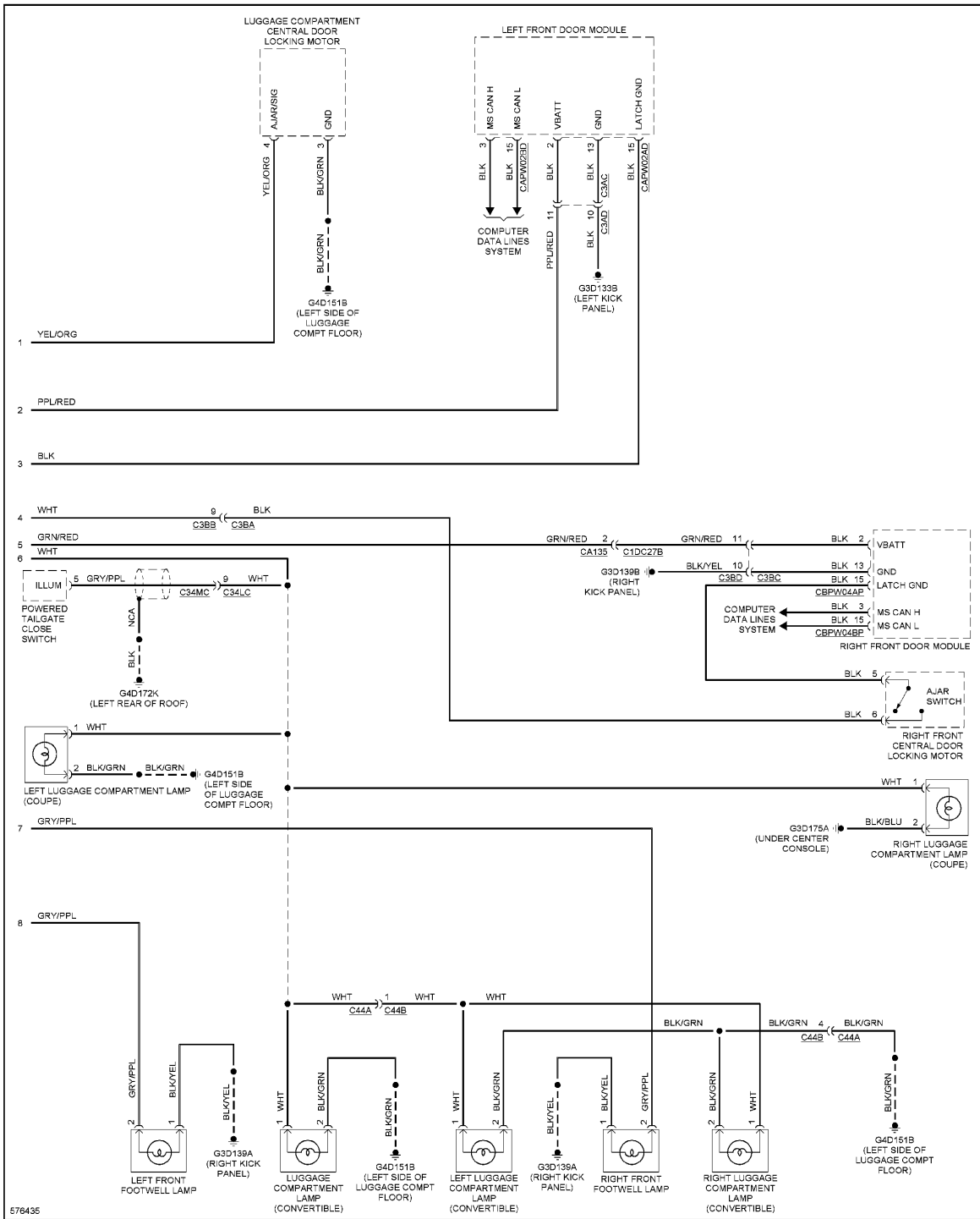


**Fig. 54: Instrument Cluster Circuit**

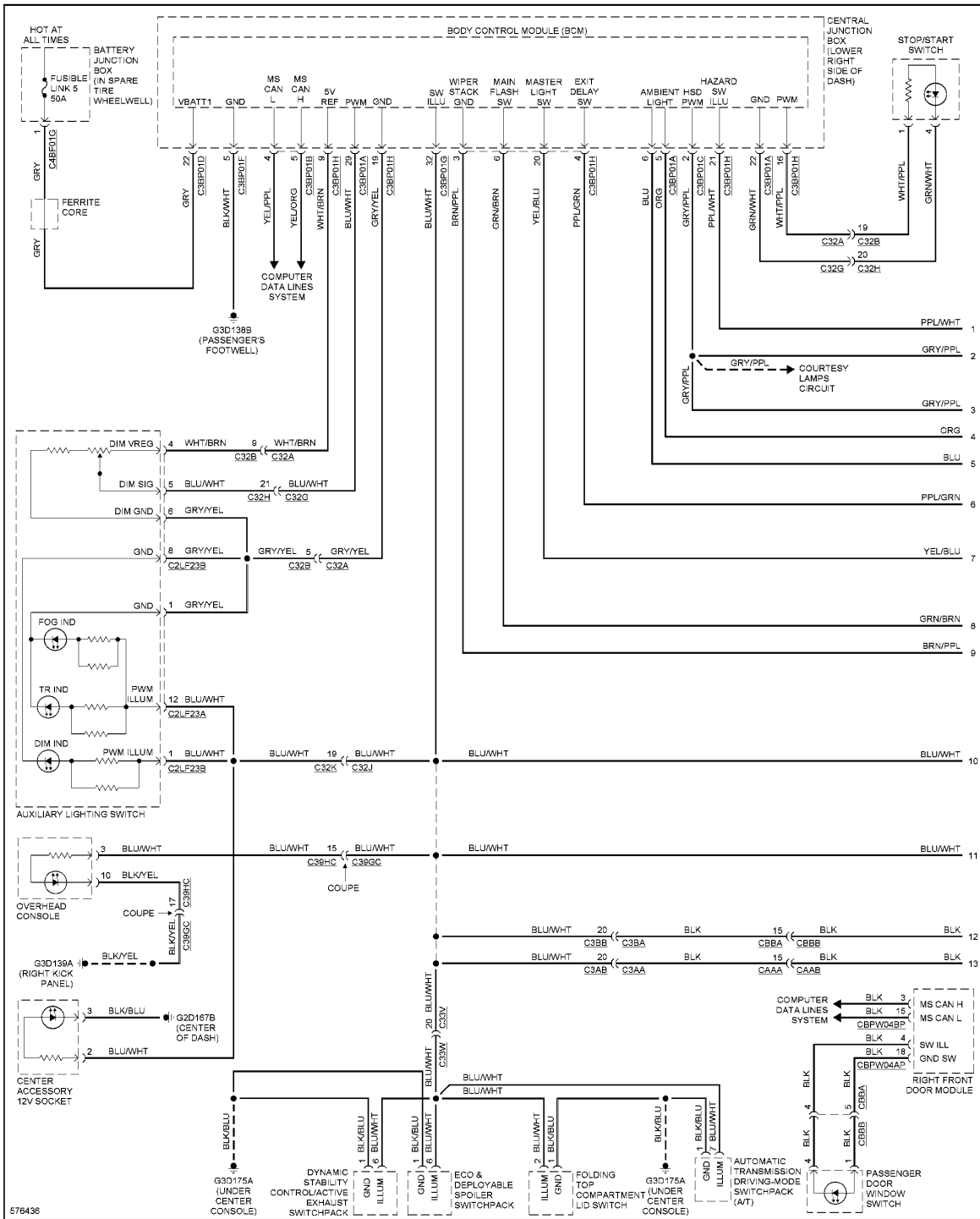
## INTERIOR LIGHTS



**Fig. 55: Courtesy Lamps Circuit (1 of 2)**



**Fig. 56: Courtesy Lamps Circuit (2 of 2)**



**Fig. 57: Instrument Illumination Circuit (1 of 2)**

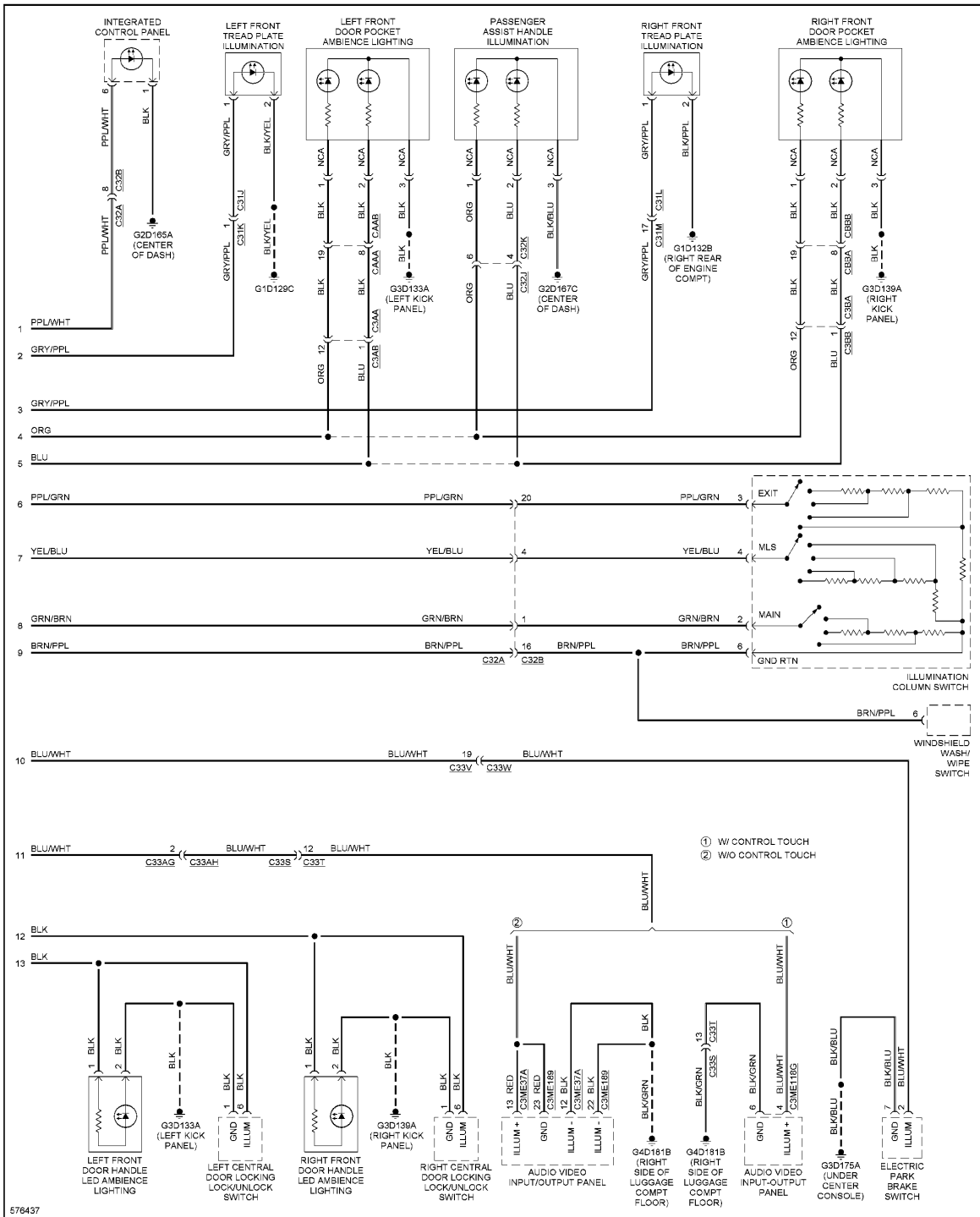
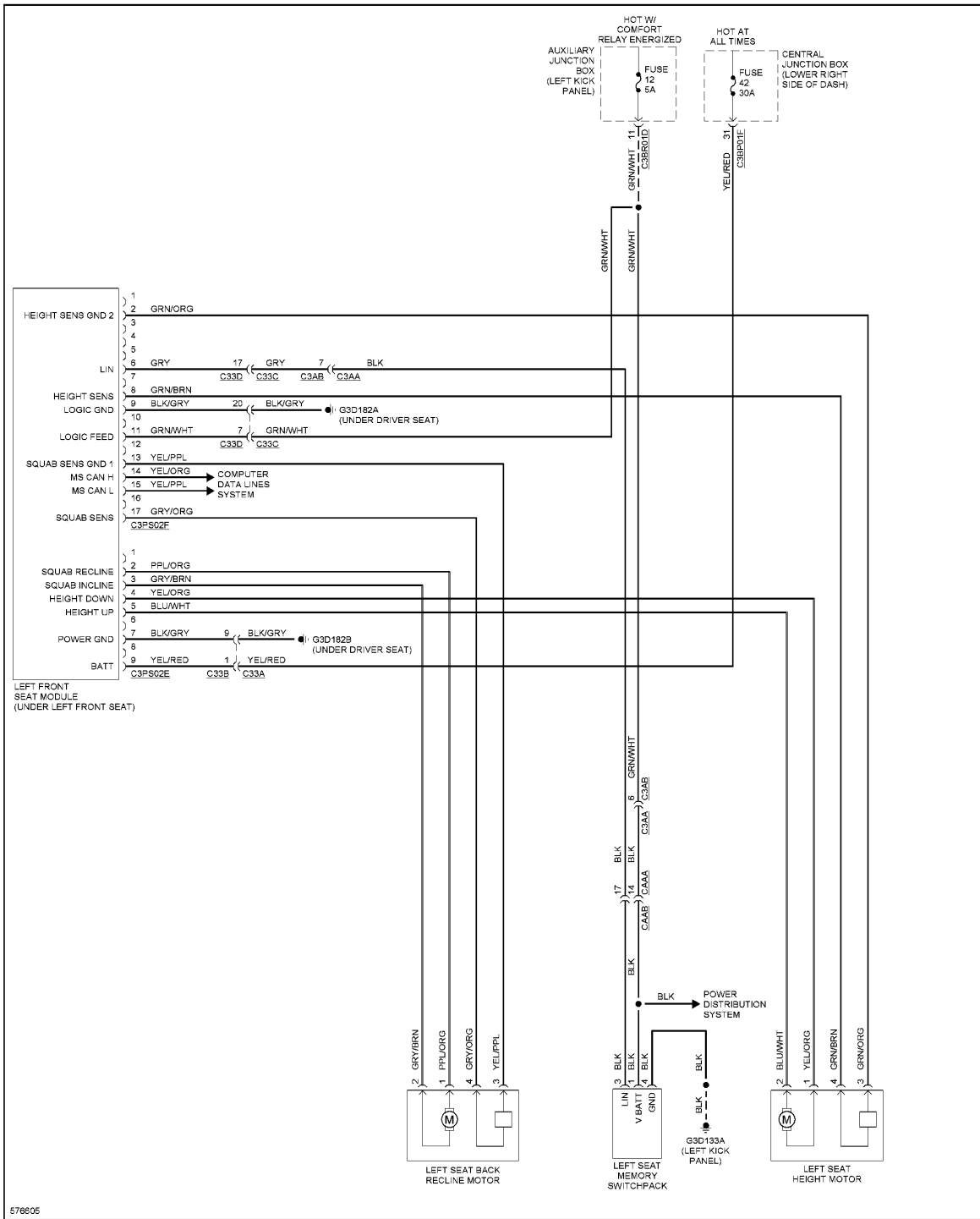
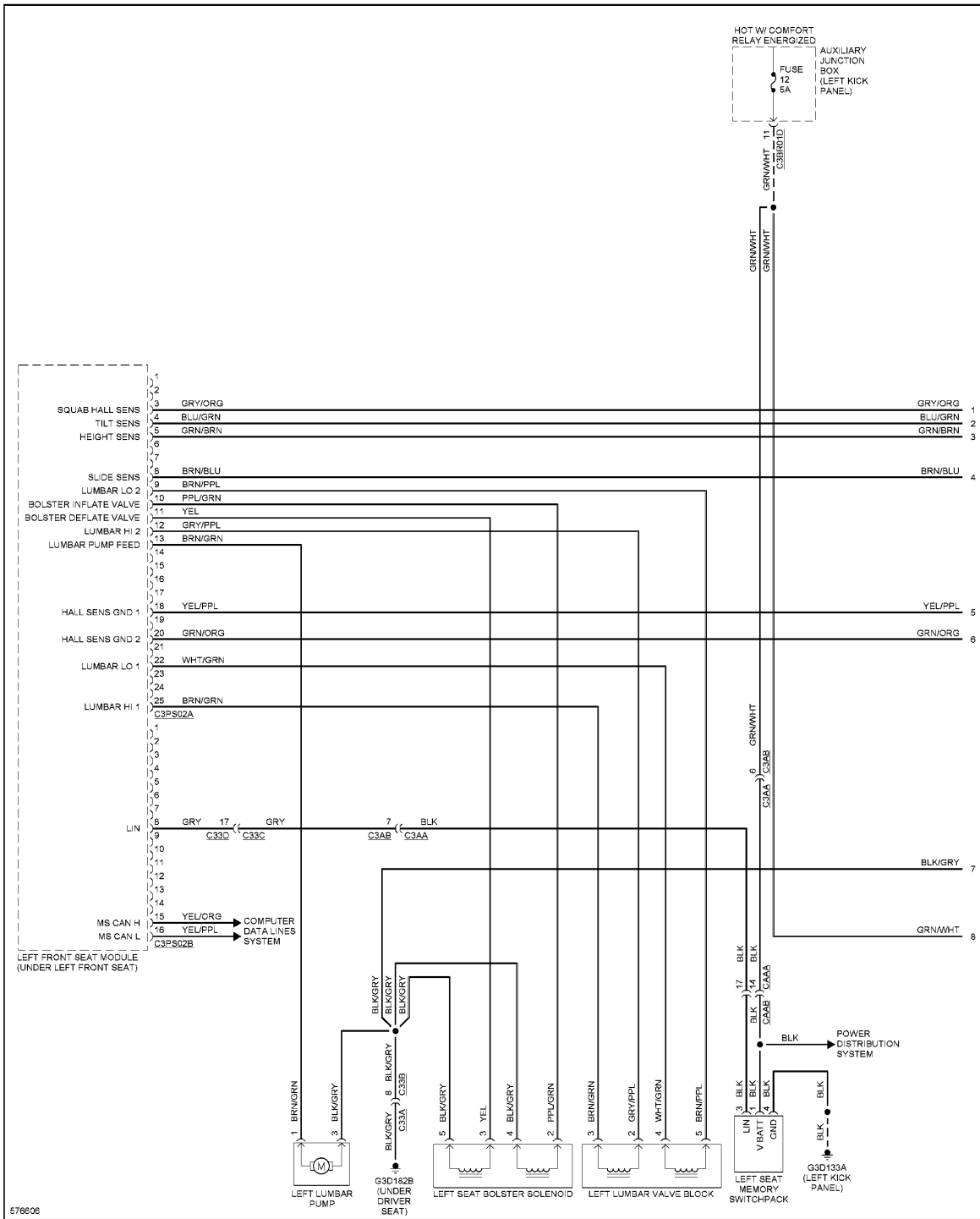


Fig. 58: Instrument Illumination Circuit (2 of 2)

## MEMORY SYSTEMS

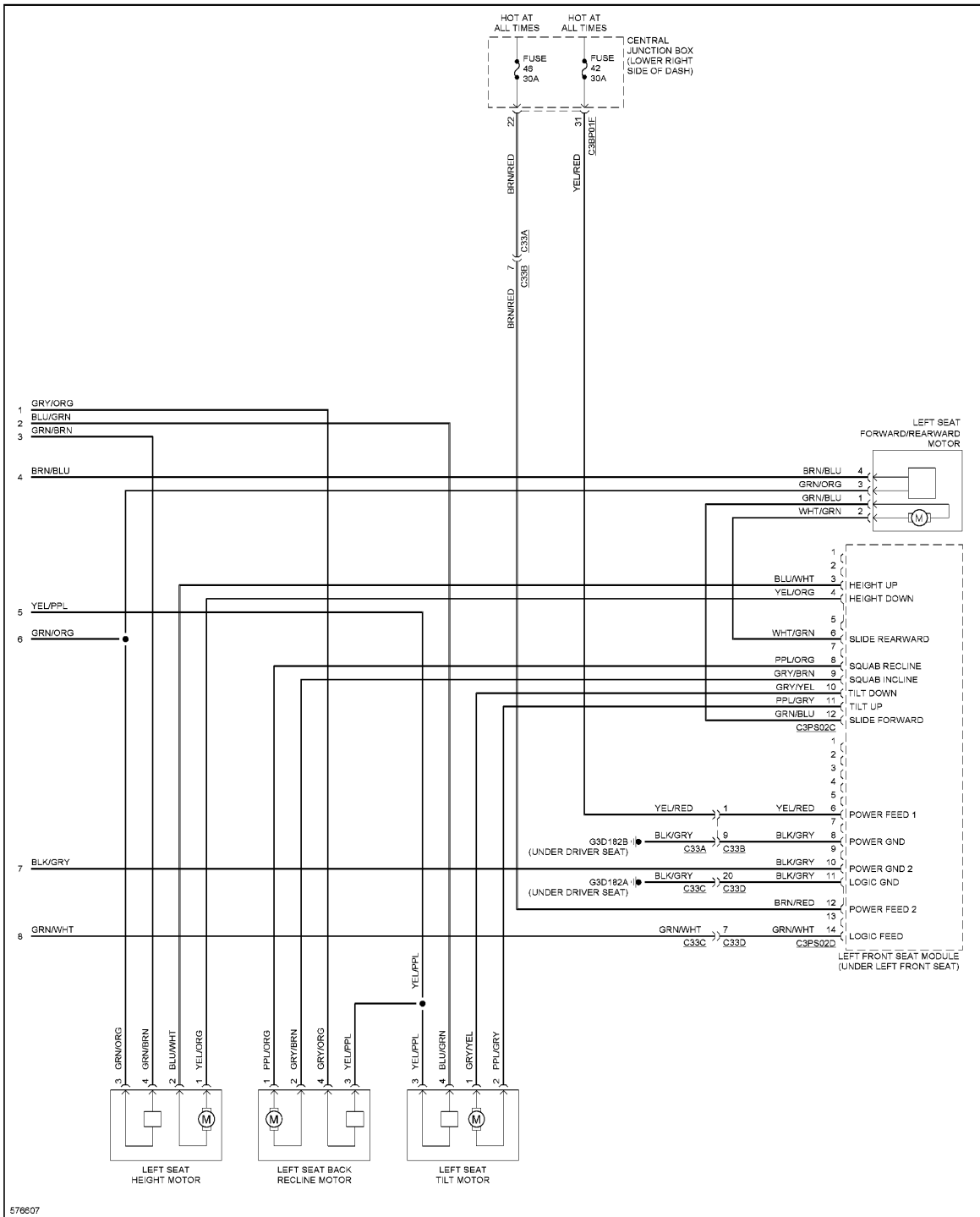


**Fig. 59: Driver's Memory Seat Circuit, 4-Way**

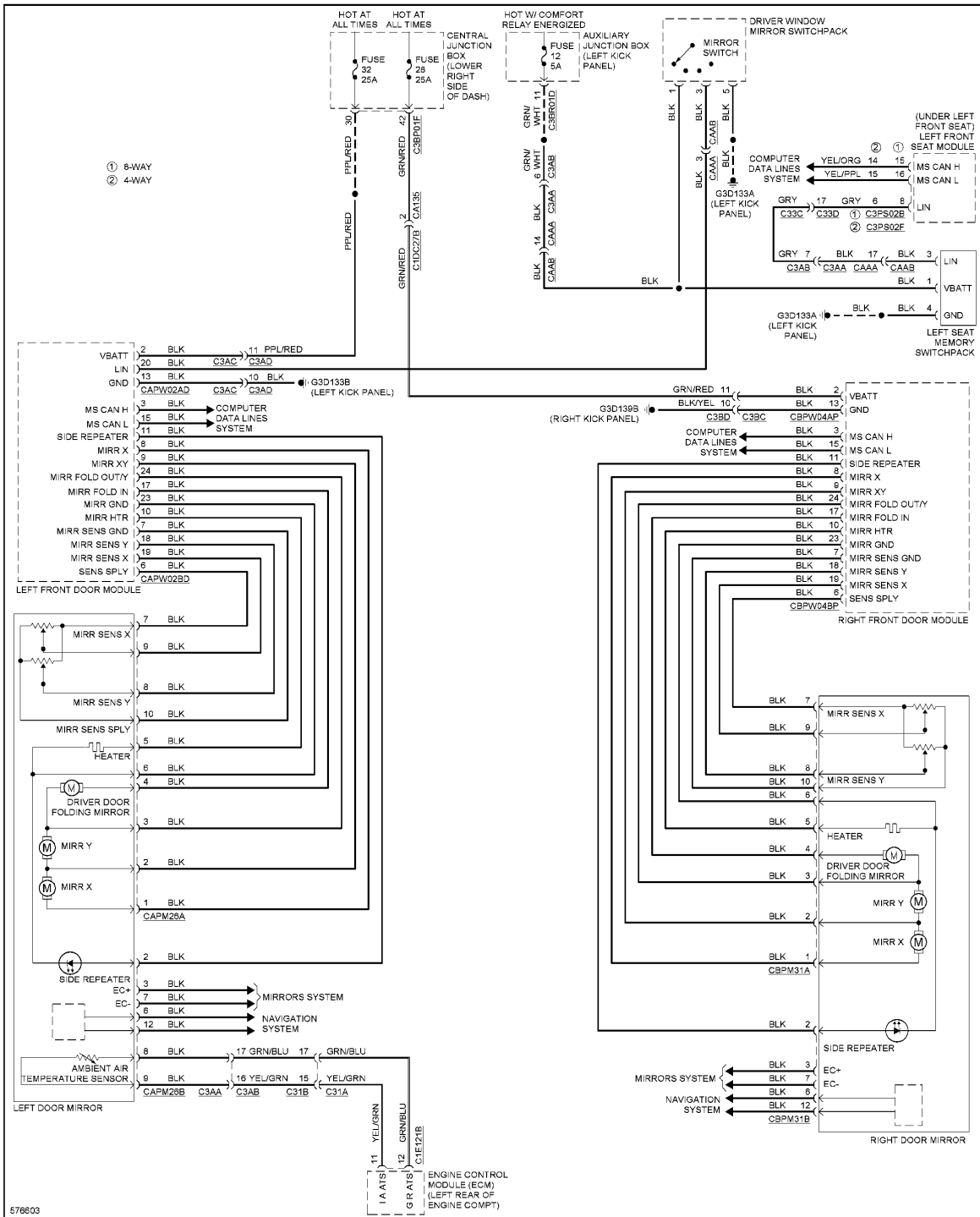


**Fig. 60: Driver's Memory Seat Circuit, 8-Way (1 of 2)**

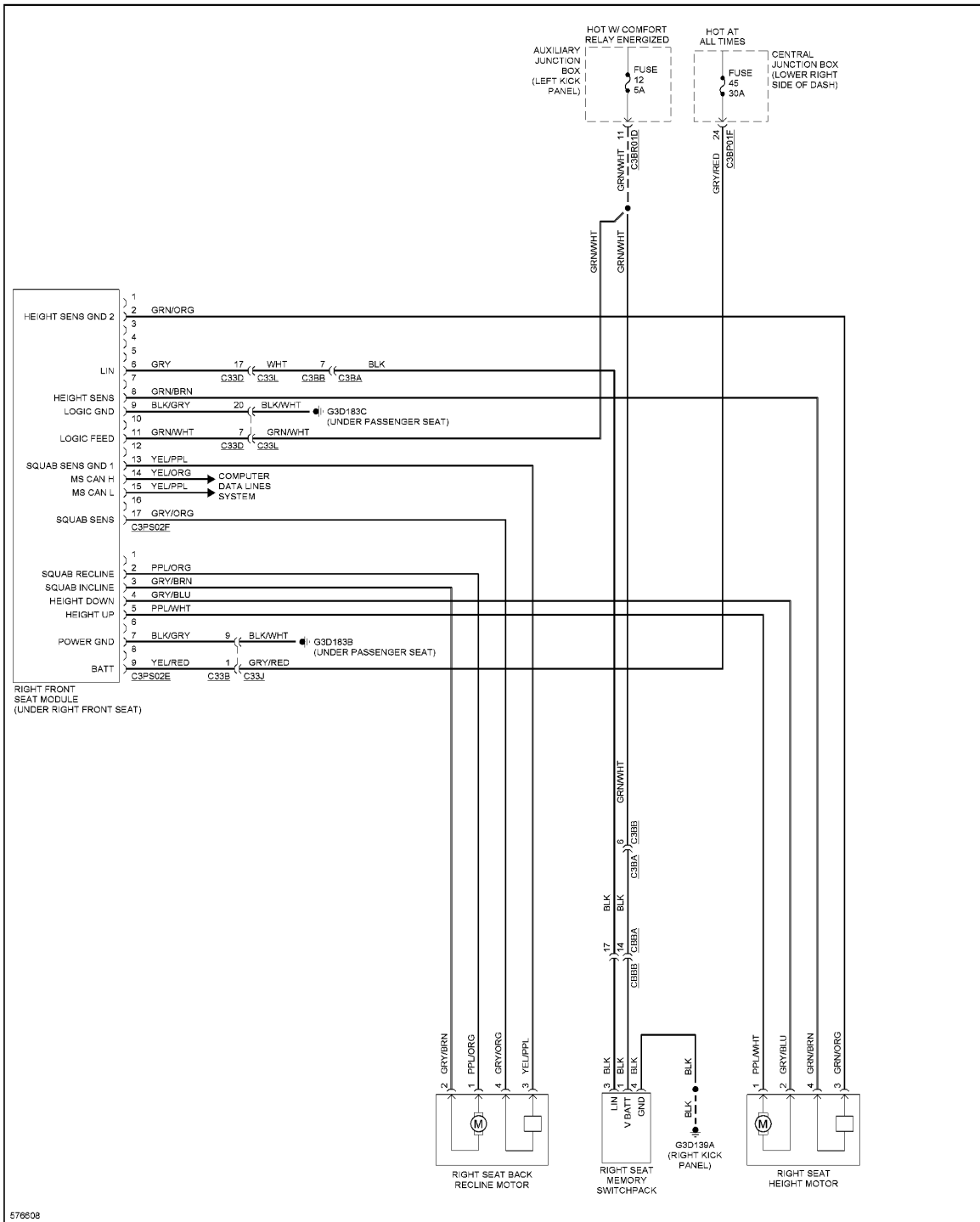




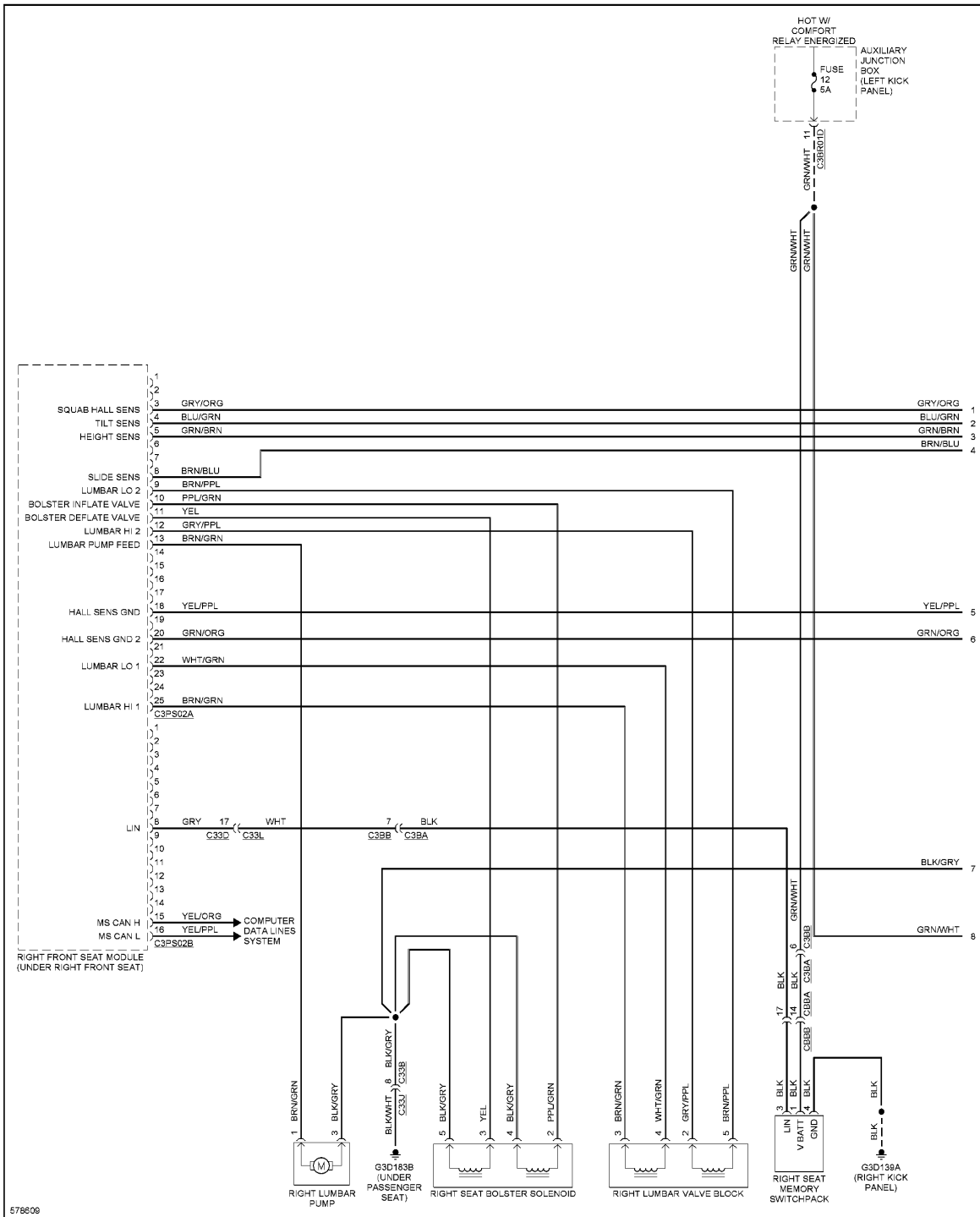
**Fig. 61: Driver's Memory Seat Circuit, 8-Way (2 of 2)**



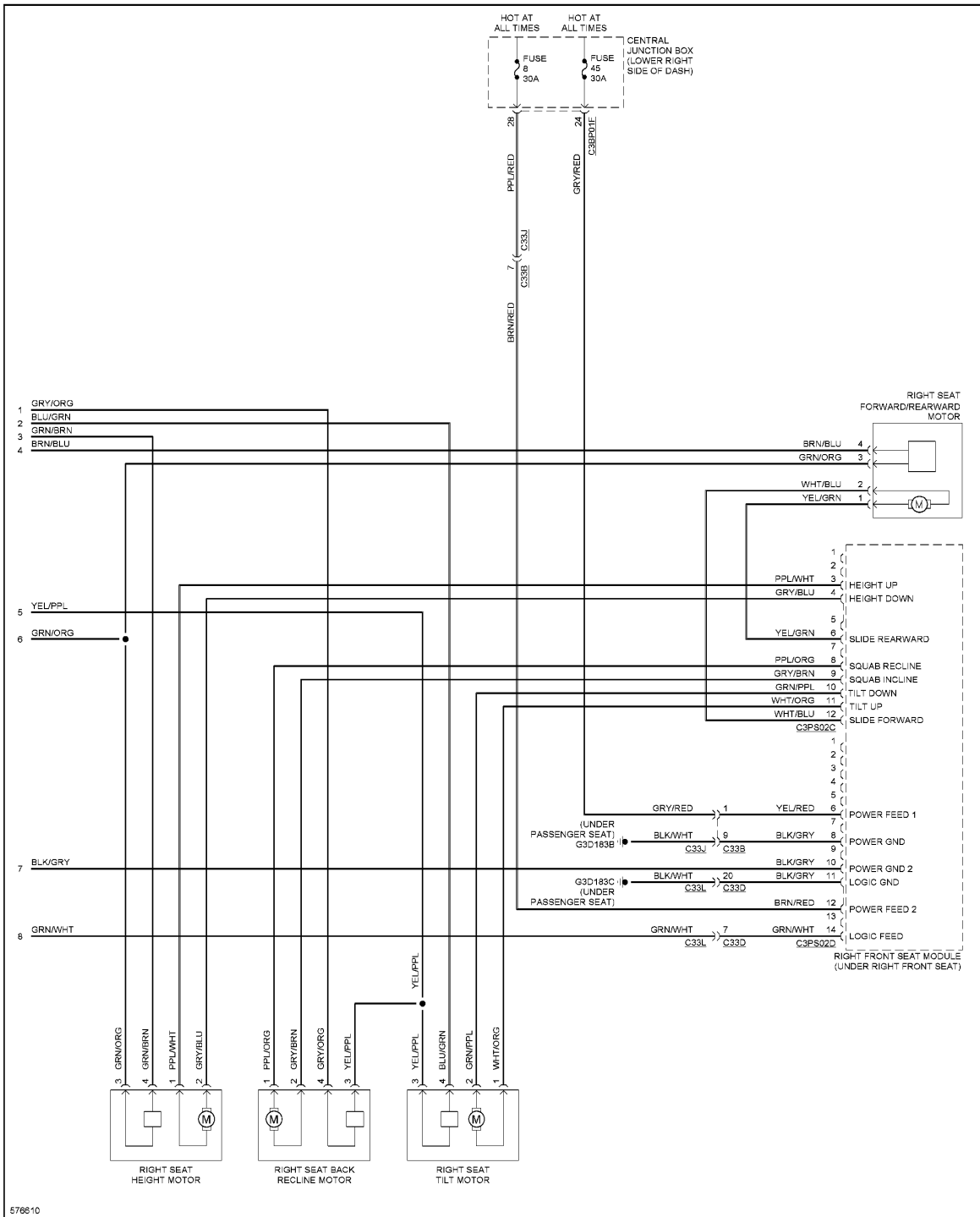
**Fig. 62: Memory Mirrors Circuit**



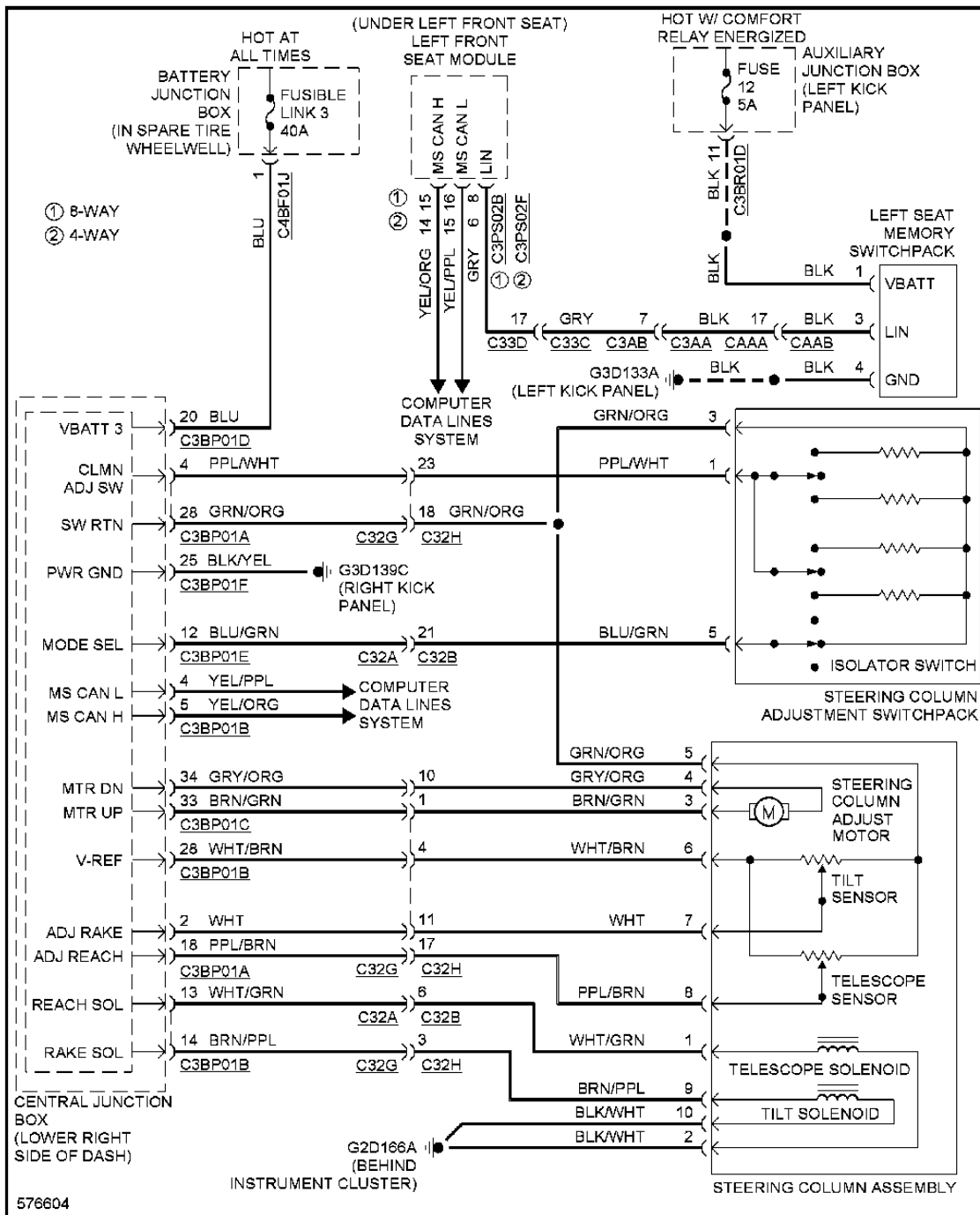
**Fig. 63: Passenger's Memory Seat Circuit, 4-Way**



**Fig. 64: Passenger's Memory Seat Circuit, 8-Way (1 of 2)**

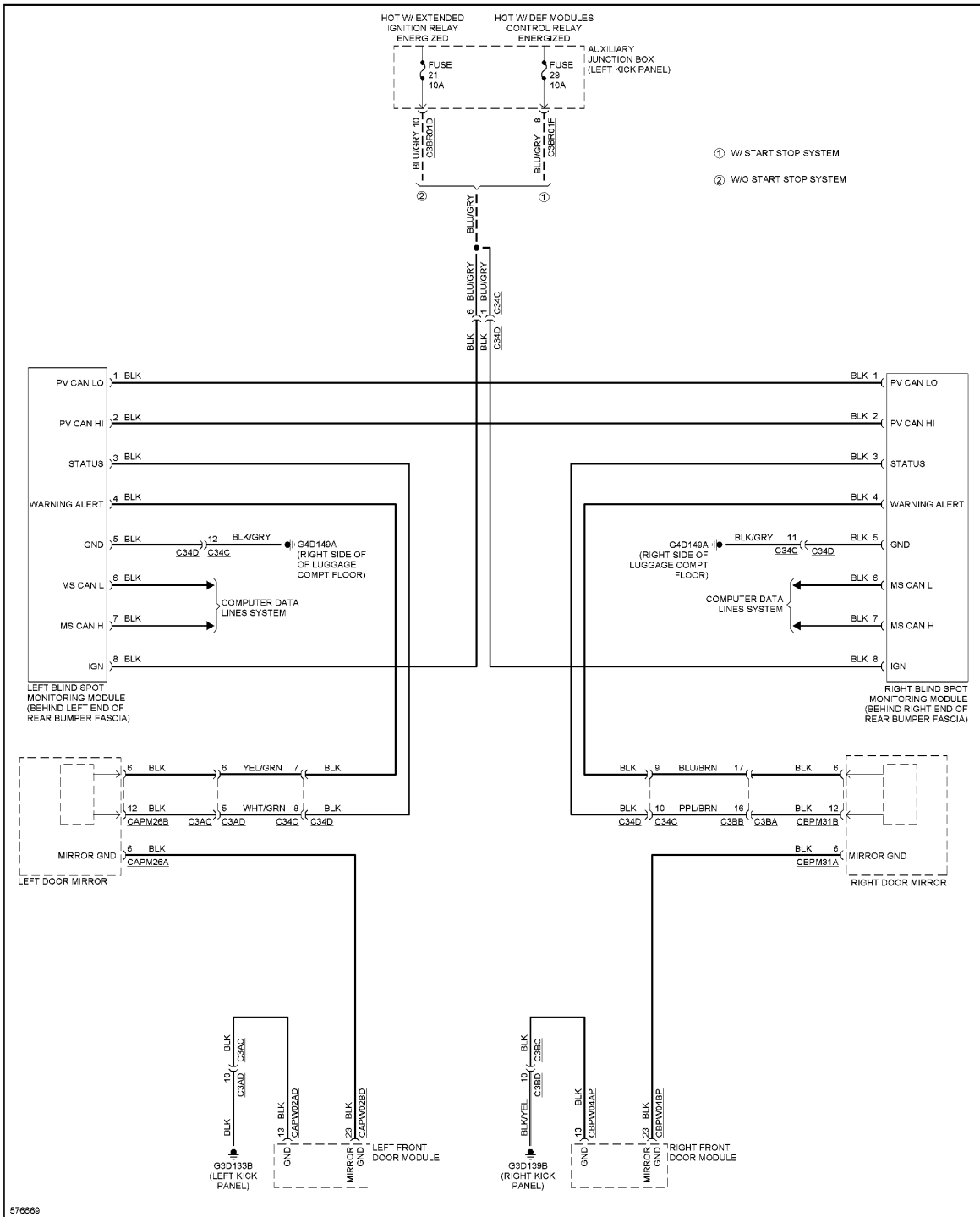


**Fig. 65: Passenger's Memory Seat Circuit, 8-Way (2 of 2)**

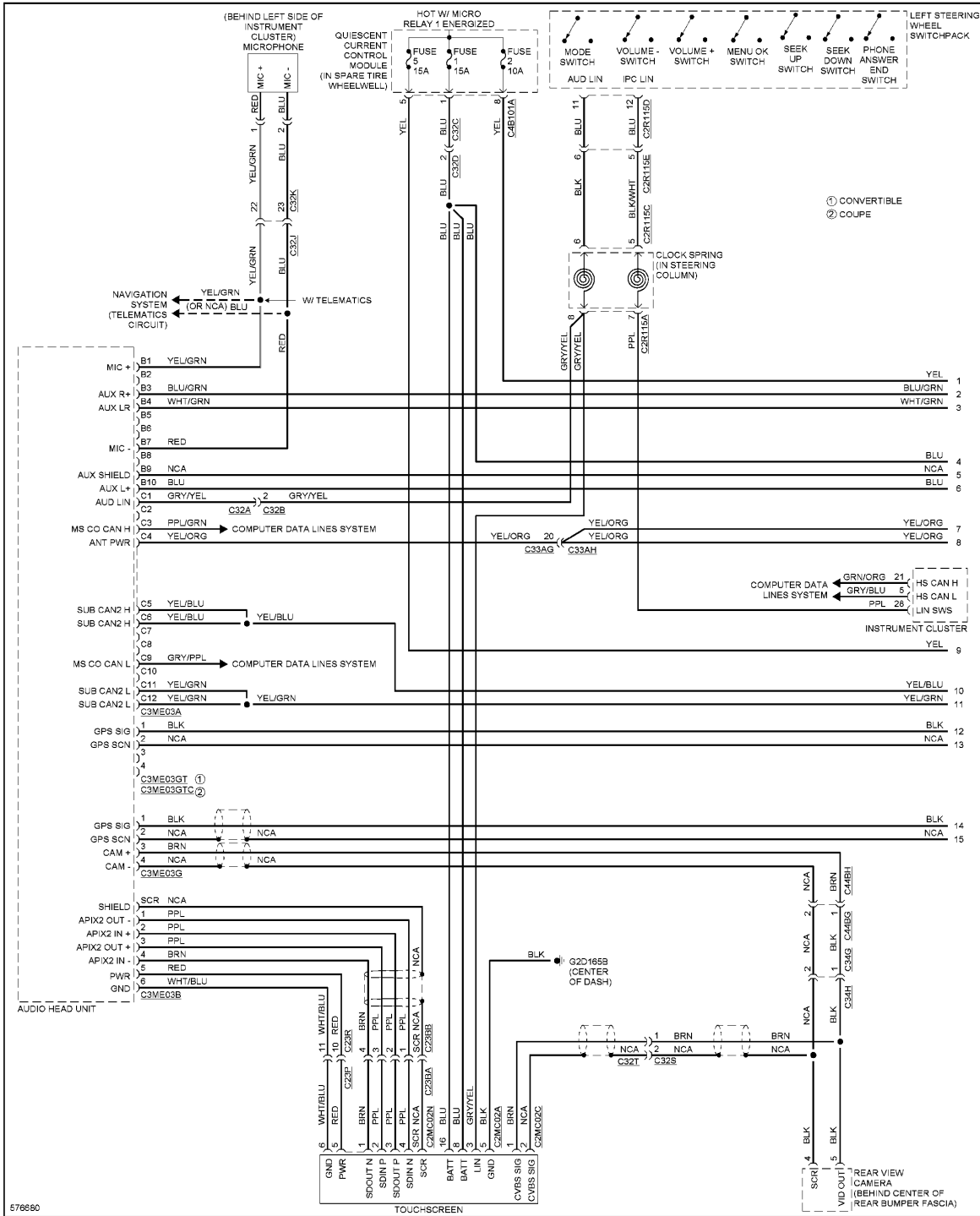


**Fig. 66: Steering Column Memory Circuit**

**NAVIGATION**

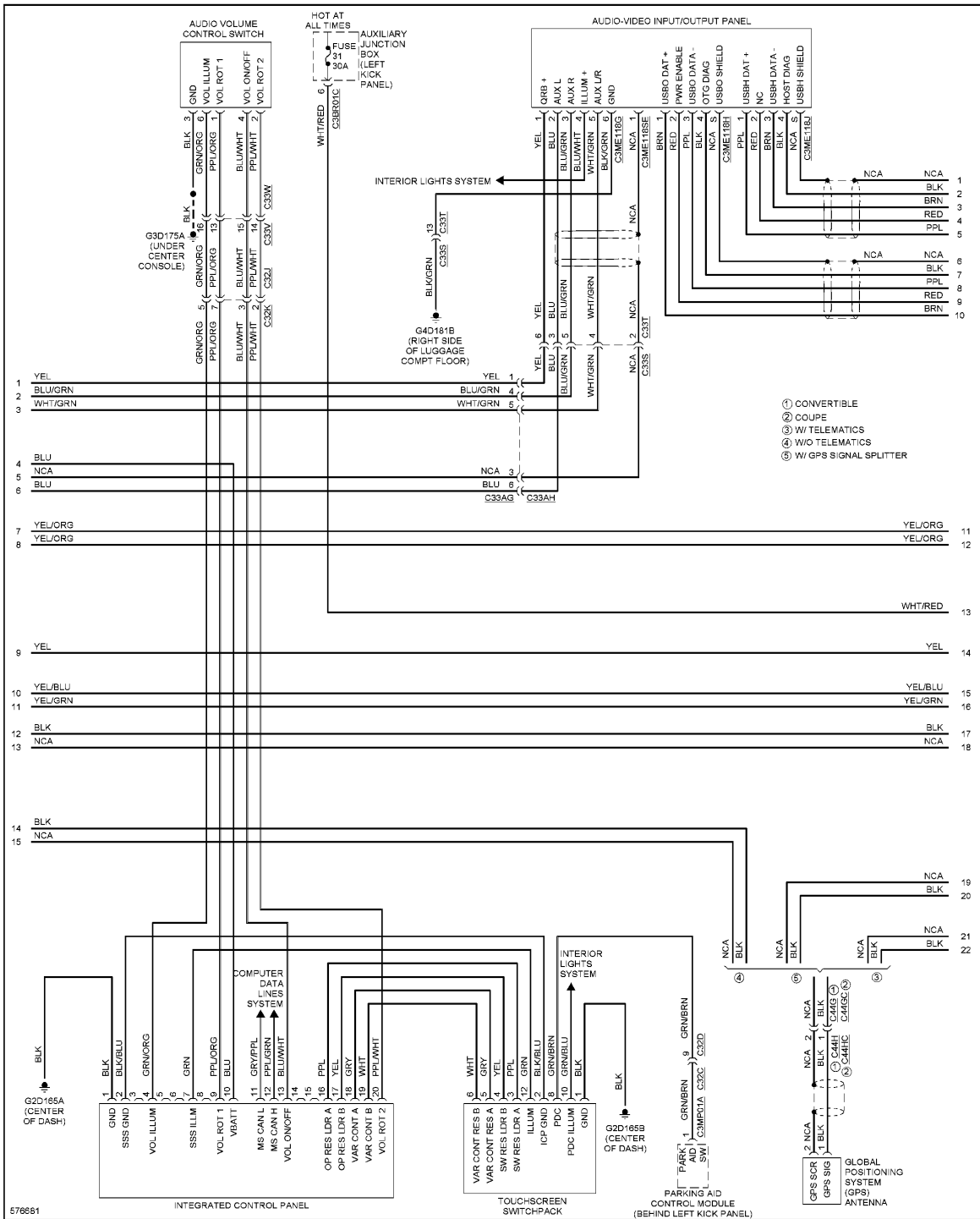


**Fig. 67: Blind Spot Monitoring Circuit**

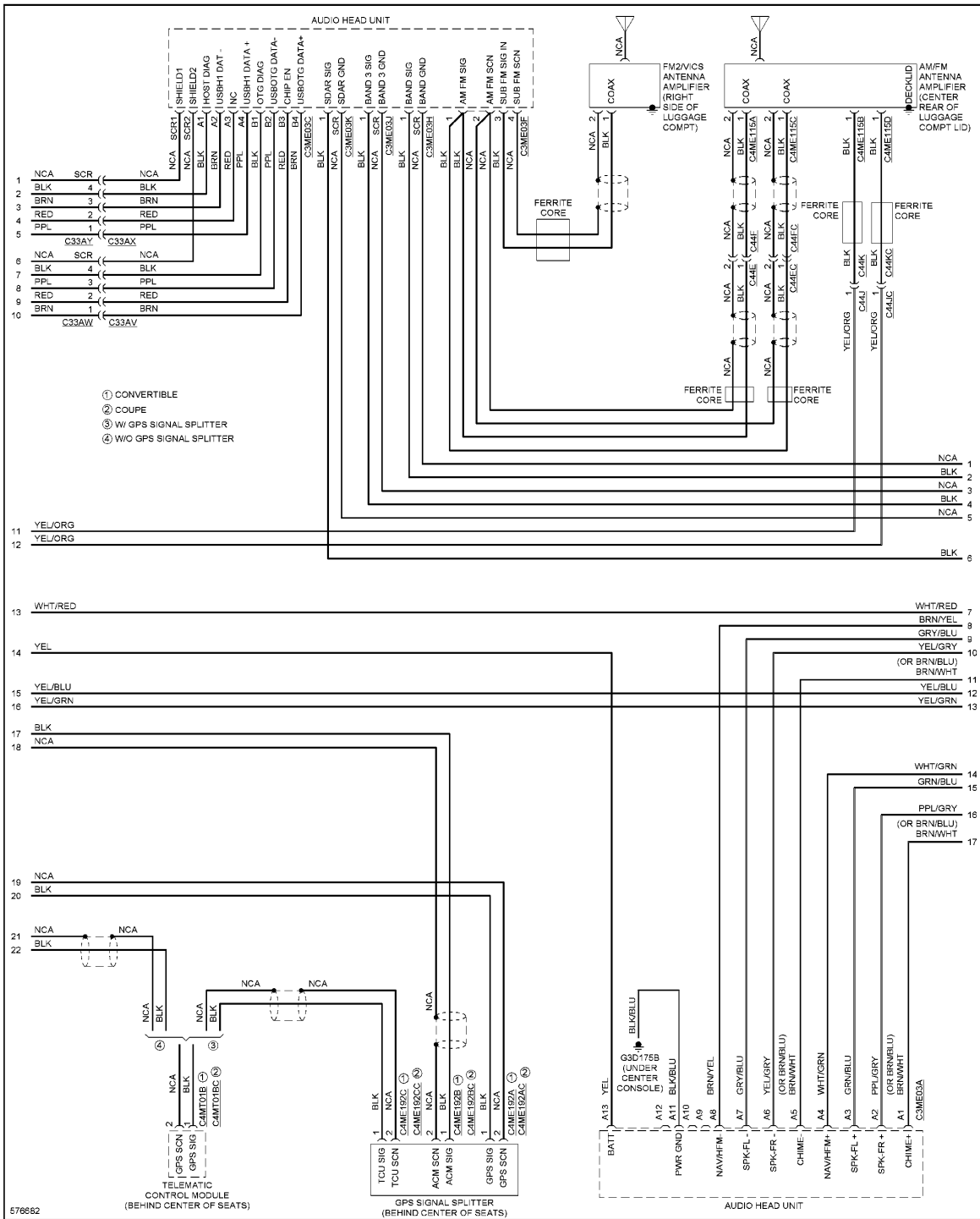


**Fig. 68: Navigation Circuit, W/ Control Touch & Hi-line Audio (1 of 5)**

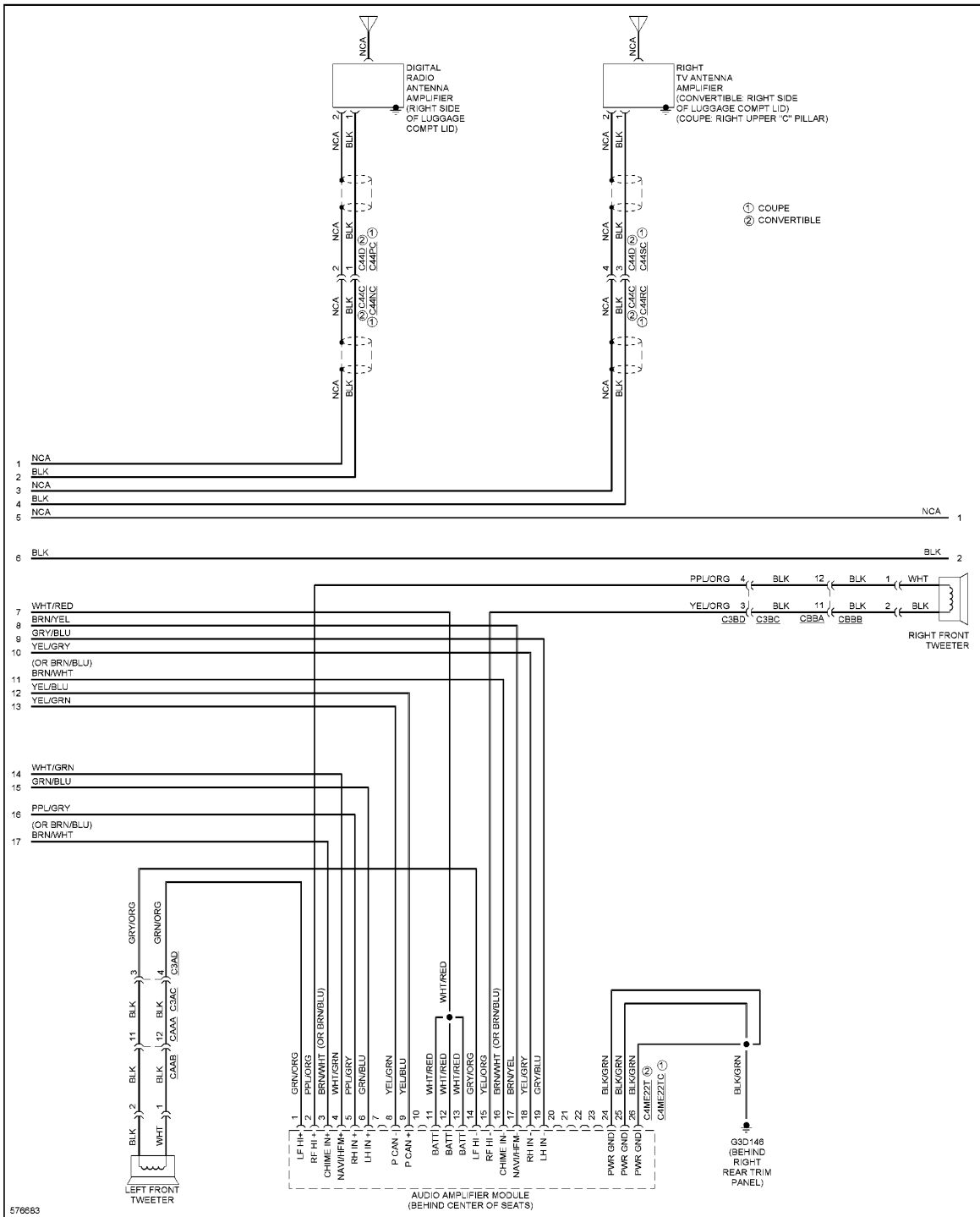




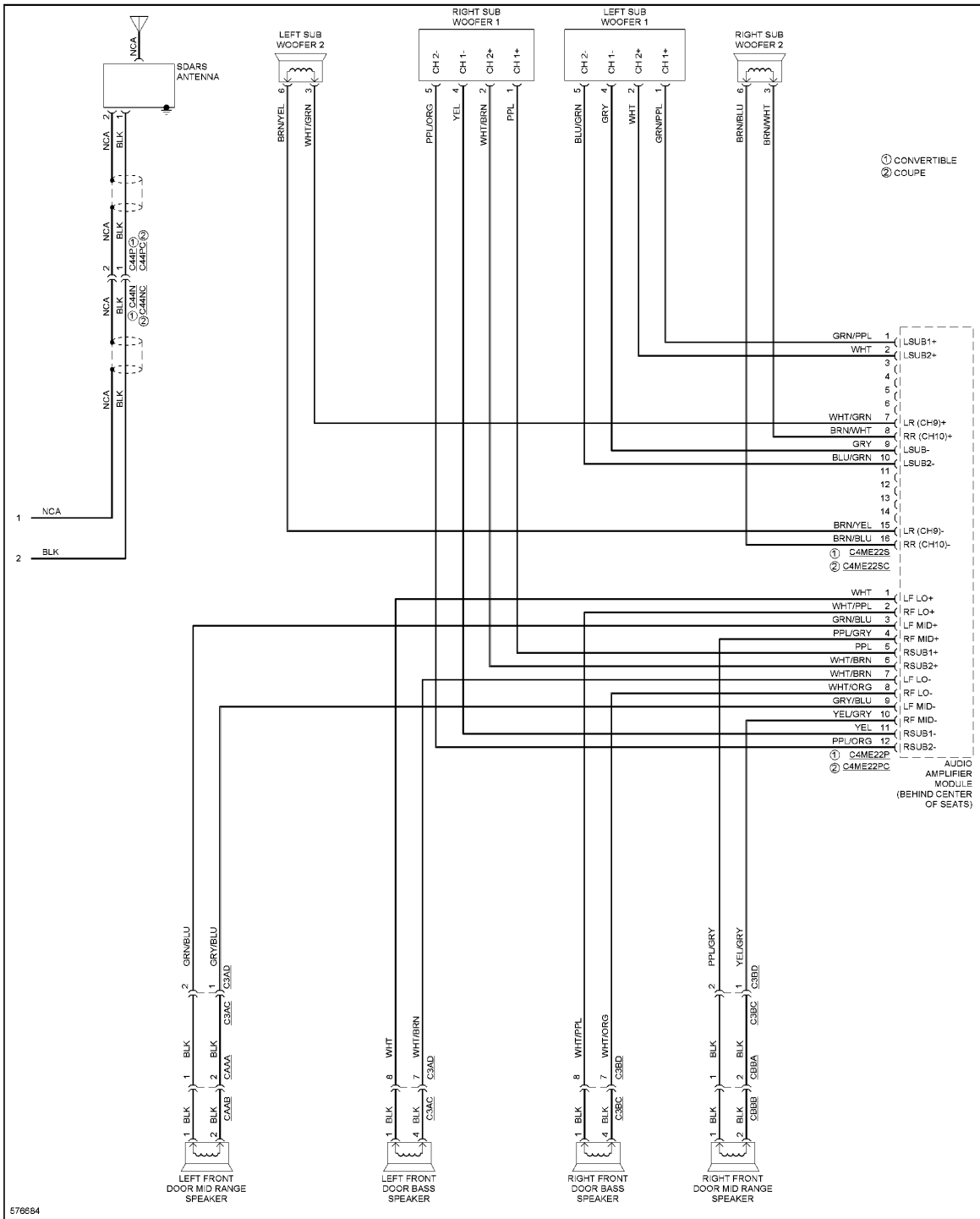
**Fig. 69: Navigation Circuit, W/ Control Touch & Hi-line Audio (2 of 5)**



**Fig. 70: Navigation Circuit, W/ Control Touch & Hi-line Audio (3 of 5)**



**Fig. 71: Navigation Circuit, W/ Control Touch & Hi-line Audio (4 of 5)**



**Fig. 72: Navigation Circuit, W/ Control Touch & Hi-line Audio (5 of 5)**

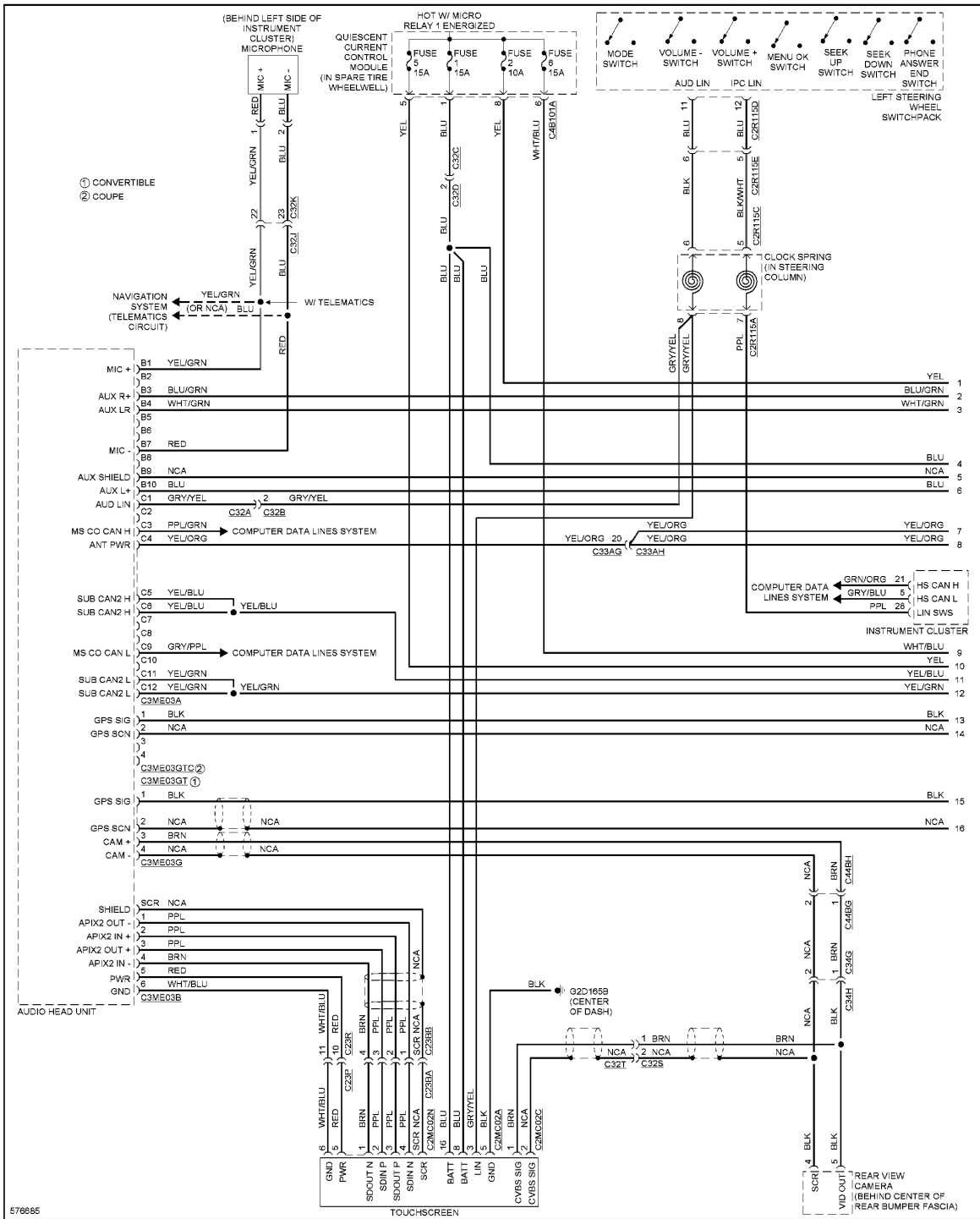
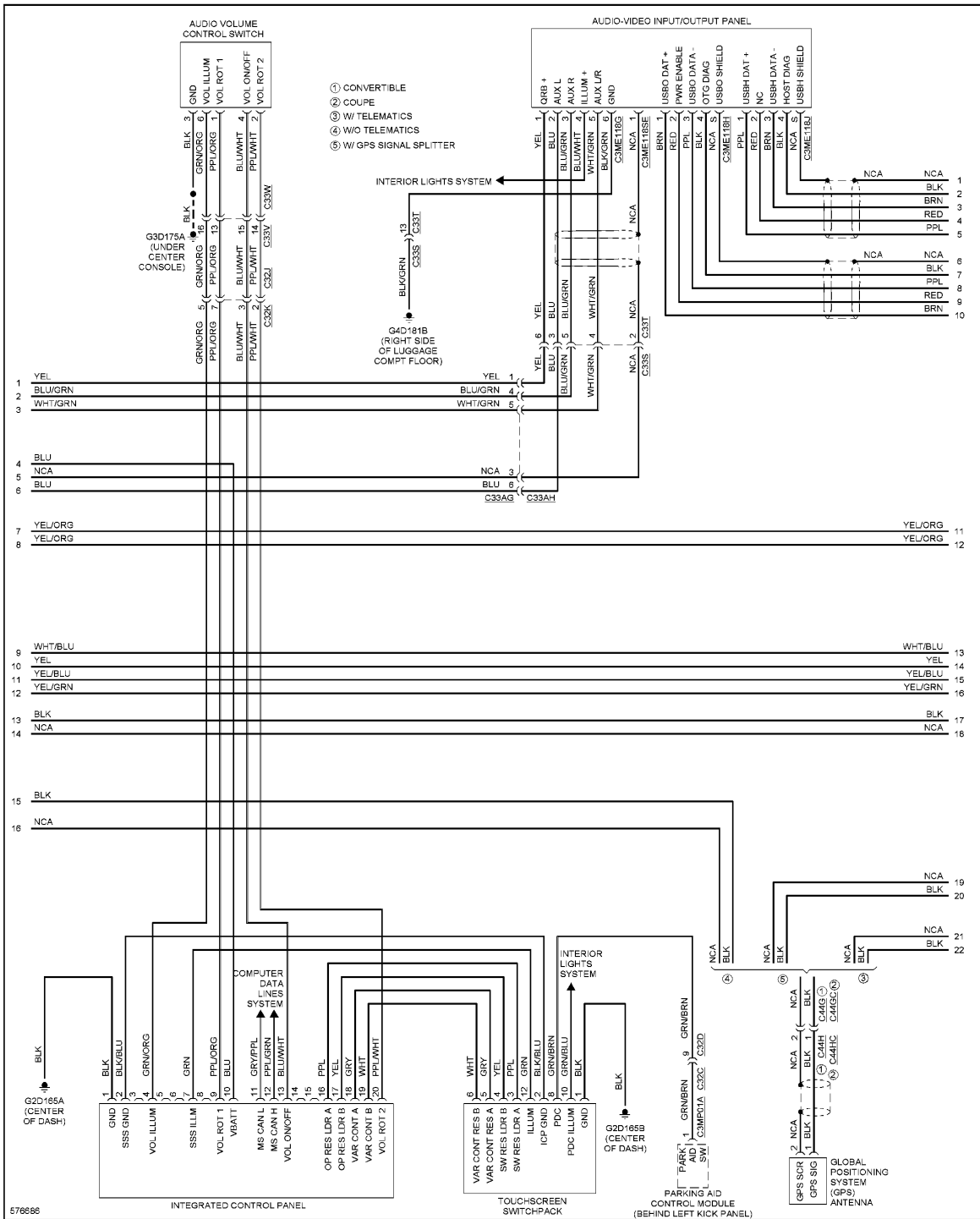
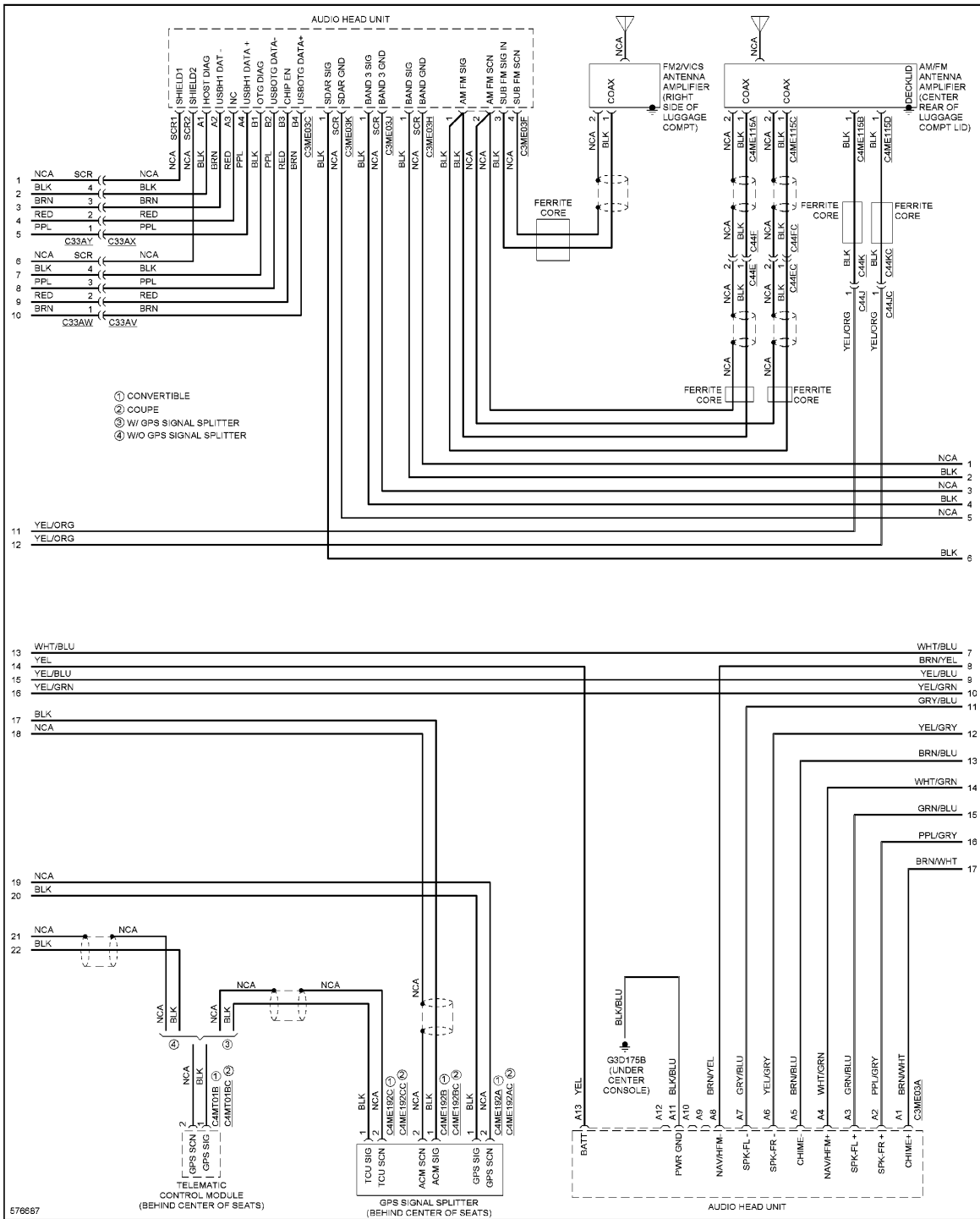


Fig. 73: Navigation Circuit, W/ Control Touch W/O Hi-line Audio (1 of 5)



**Fig. 74: Navigation Circuit, W/ Control Touch W/O Hi-line Audio (2 of 5)**



**Fig. 75: Navigation Circuit, W/ Control Touch W/O Hi-line Audio (3 of 5)**

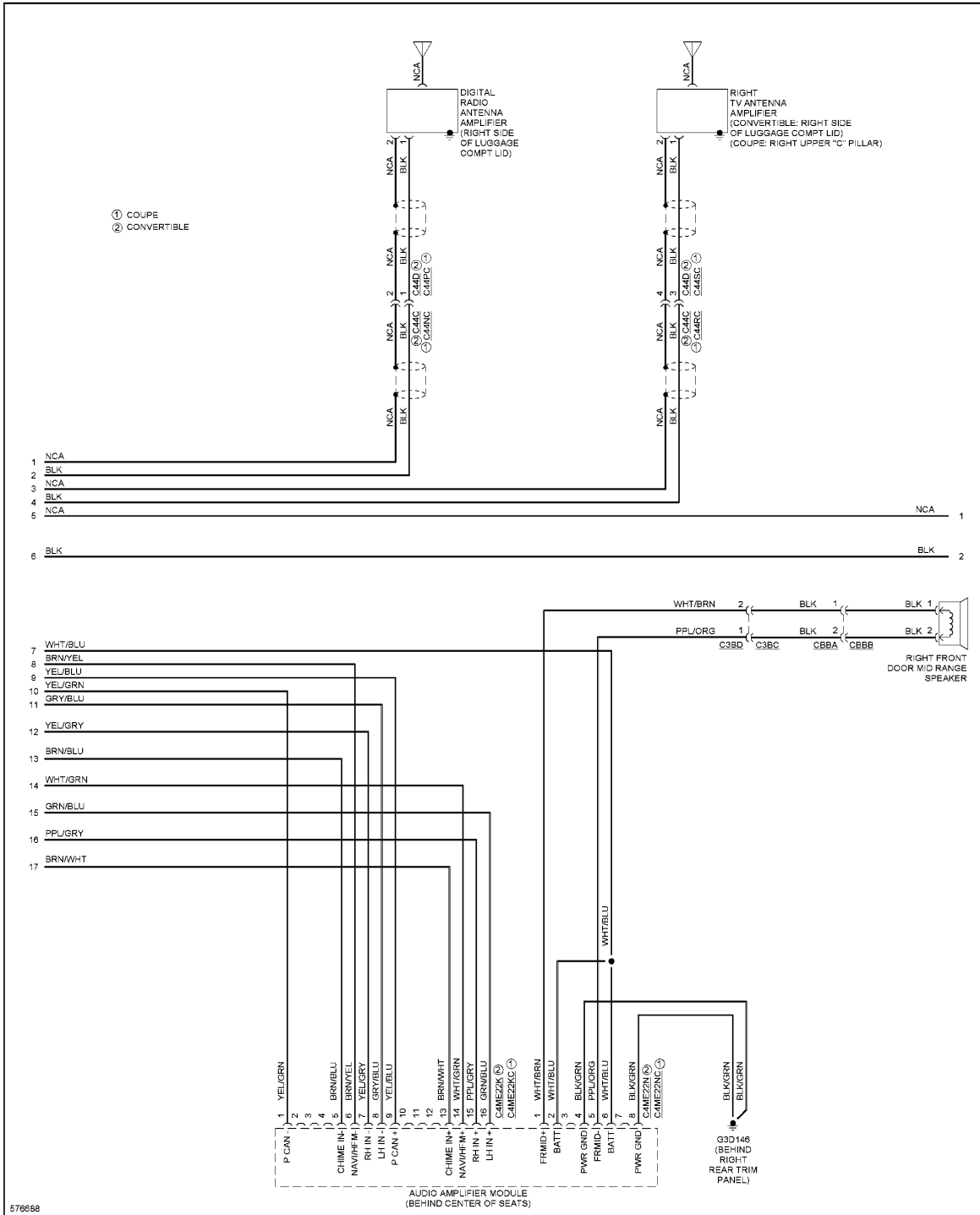
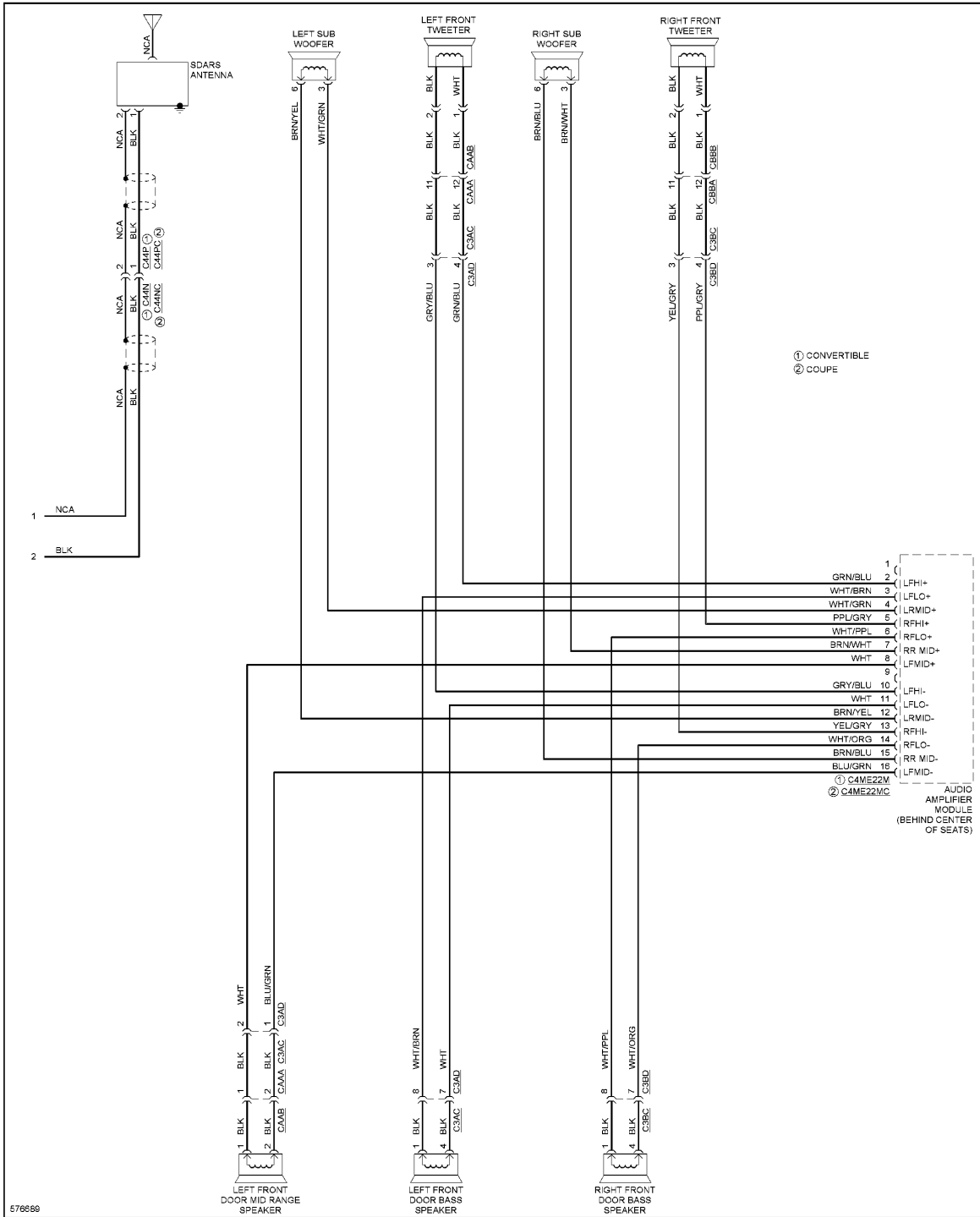
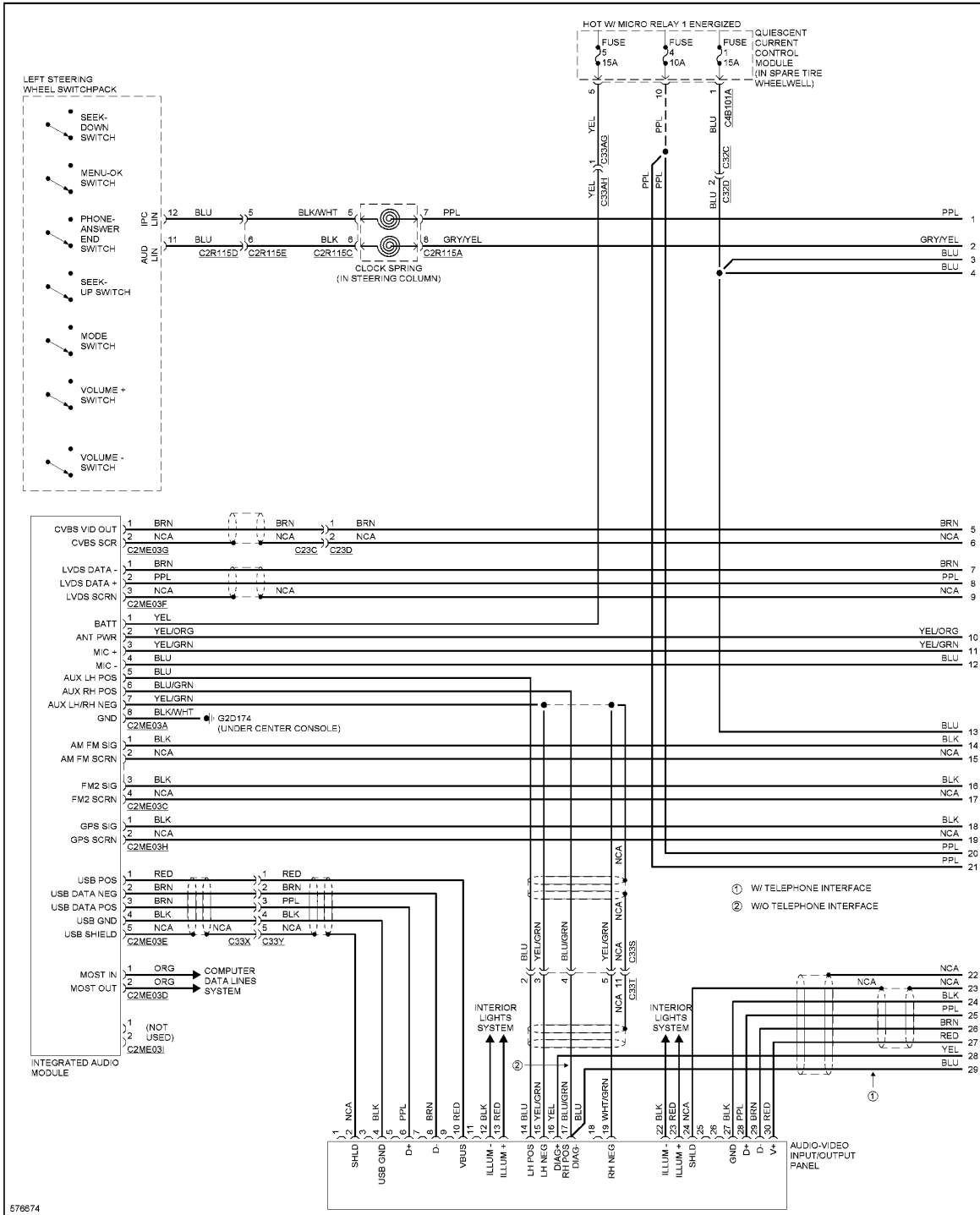


Fig. 76: Navigation Circuit, W/ Control Touch W/O Hi-line Audio (4 of 5)

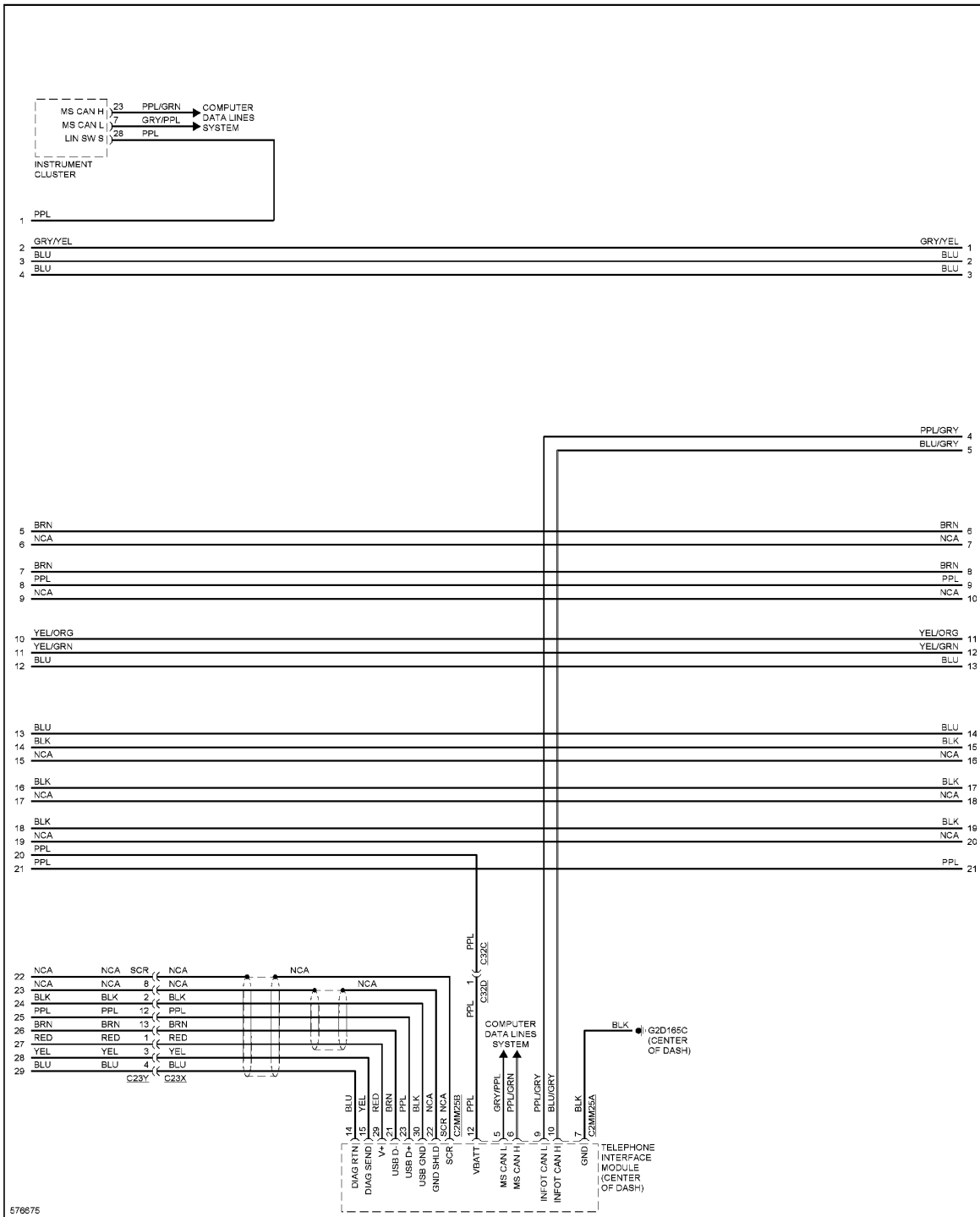




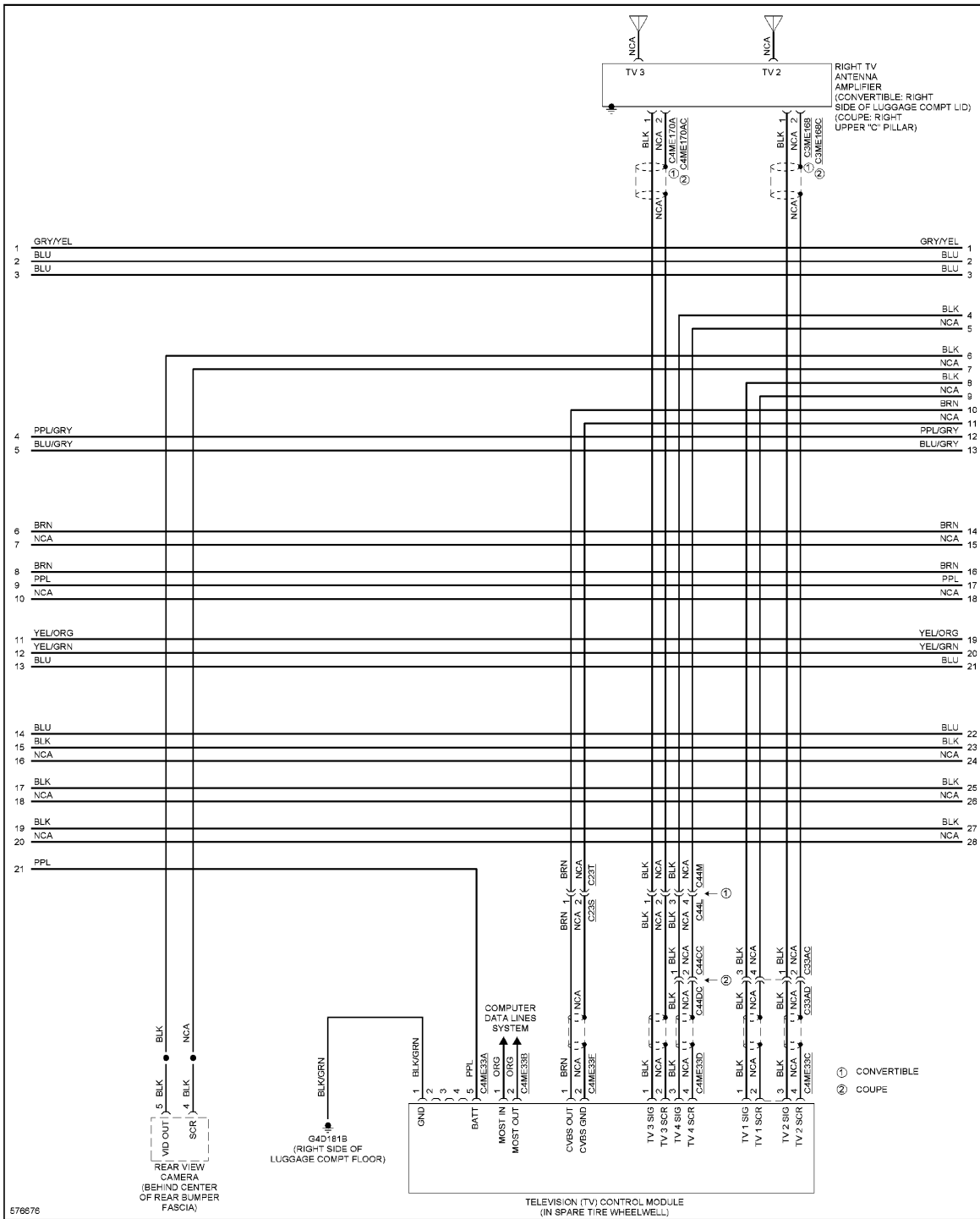
**Fig. 77: Navigation Circuit, W/ Control Touch W/O Hi-line Audio (5 of 5)**



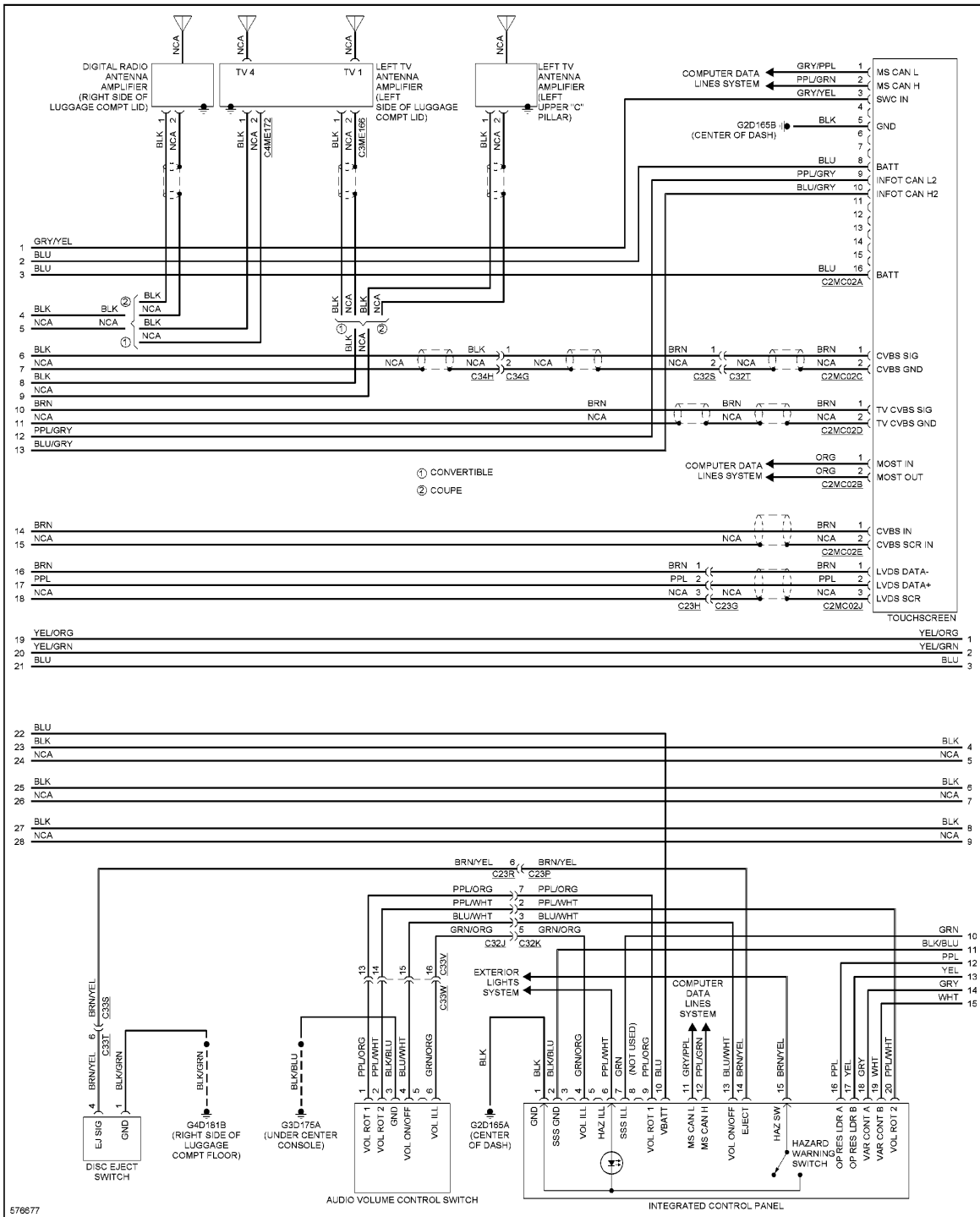
**Fig. 78: Navigation Circuit, W/O Control Touch (1 of 6)**



**Fig. 79: Navigation Circuit, W/O Control Touch (2 of 6)**



**Fig. 80: Navigation Circuit, W/O Control Touch (3 of 6)**



**Fig. 81: Navigation Circuit, W/O Control Touch (4 of 6)**

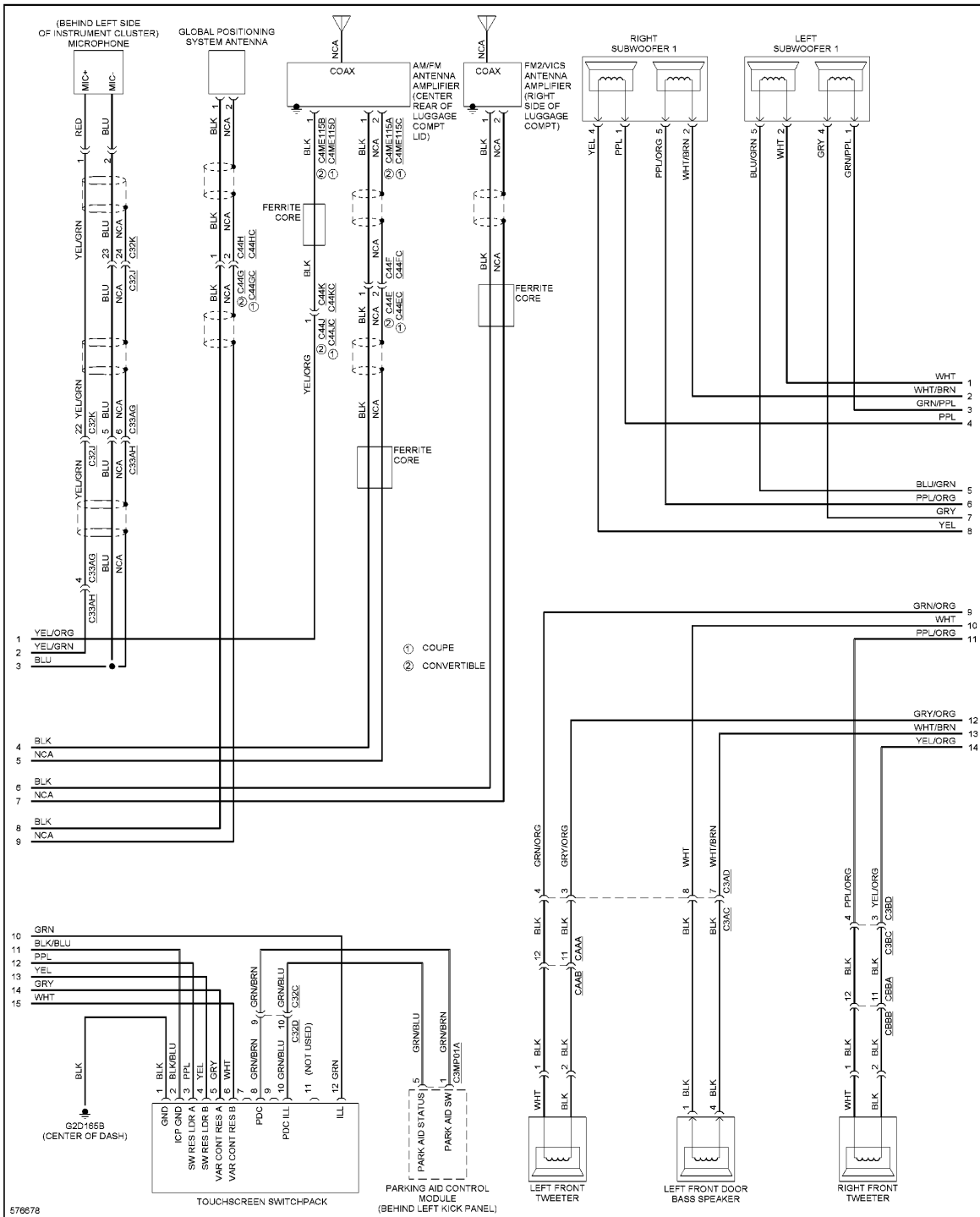
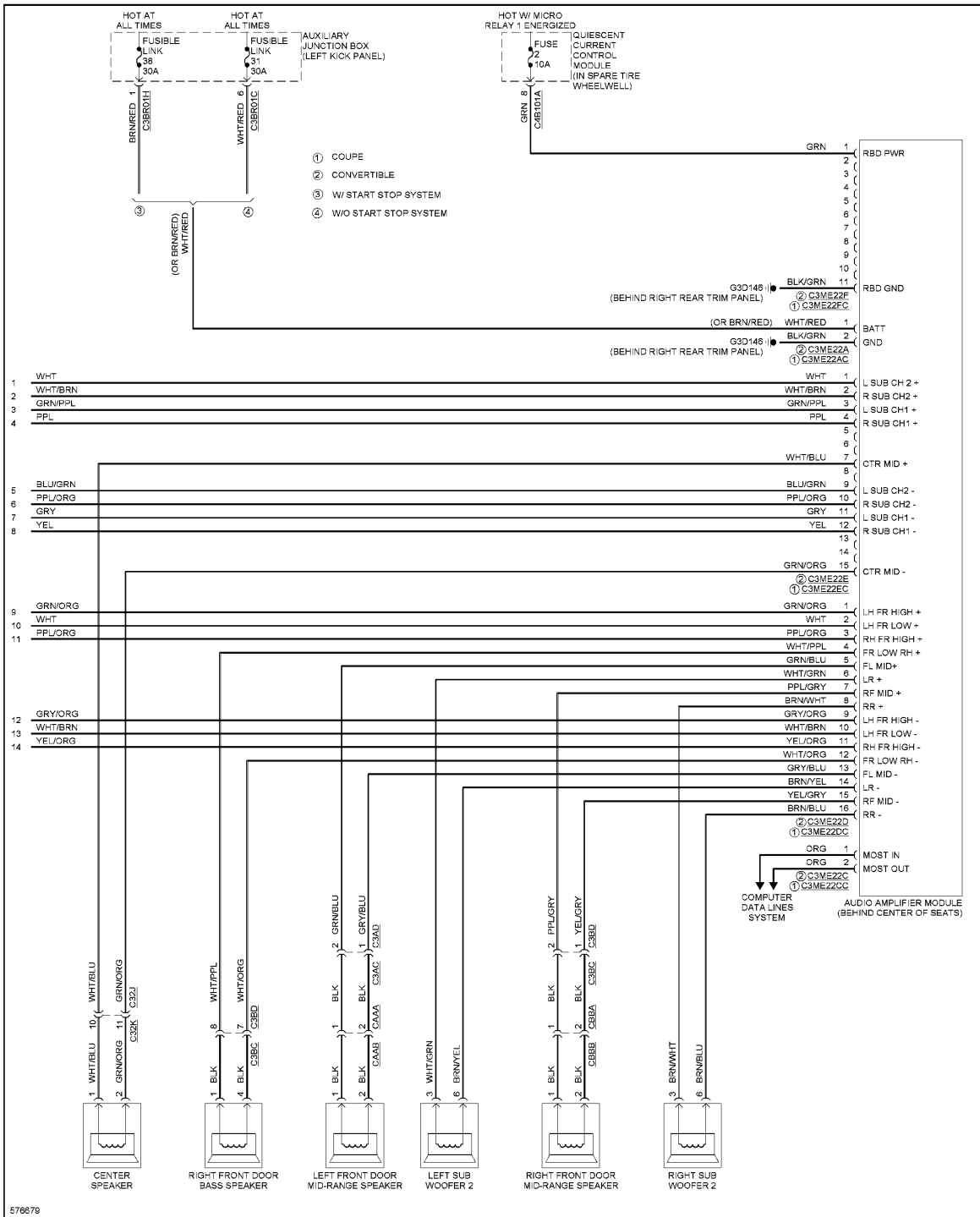
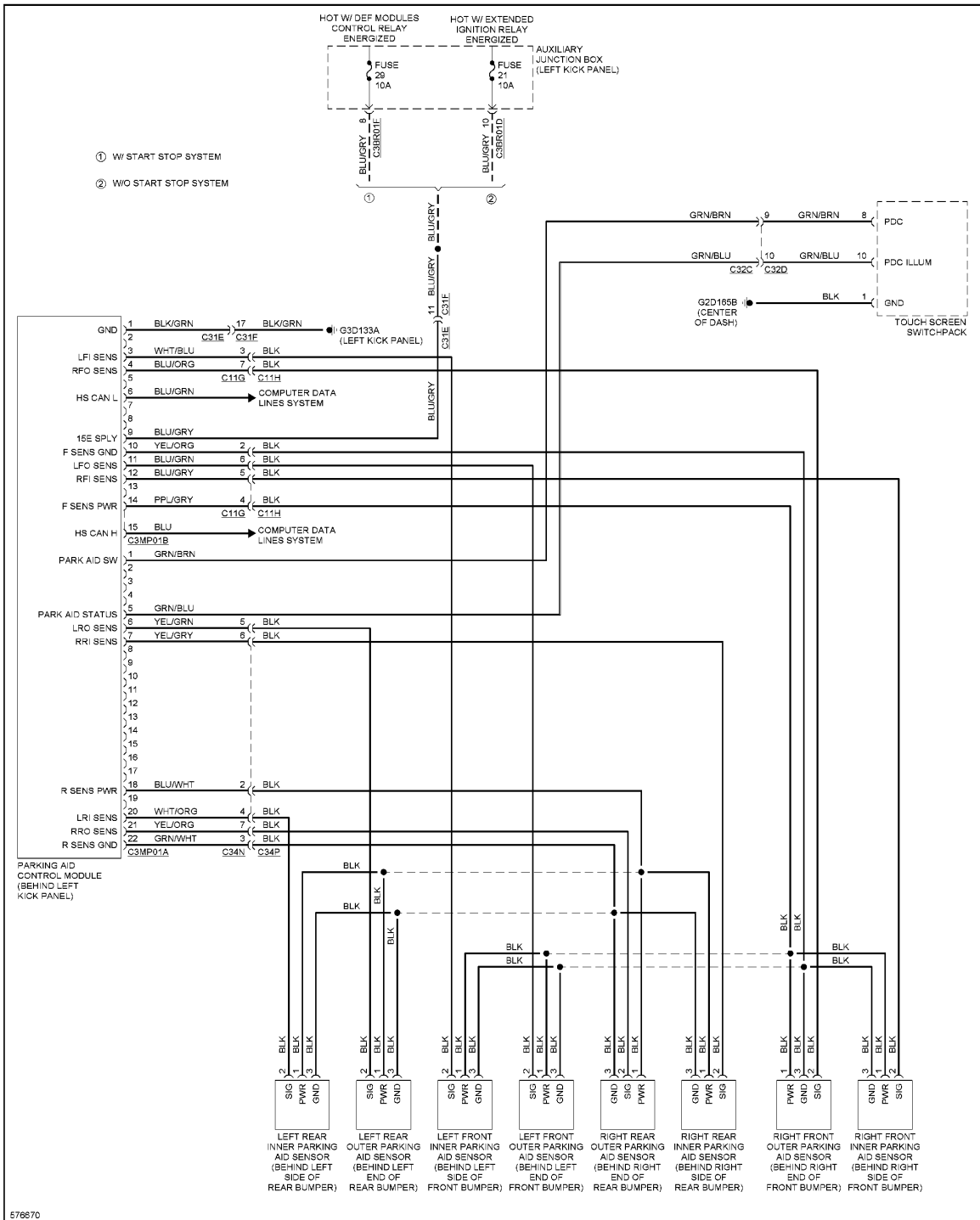


Fig. 82: Navigation Circuit, W/O Control Touch (5 of 6)

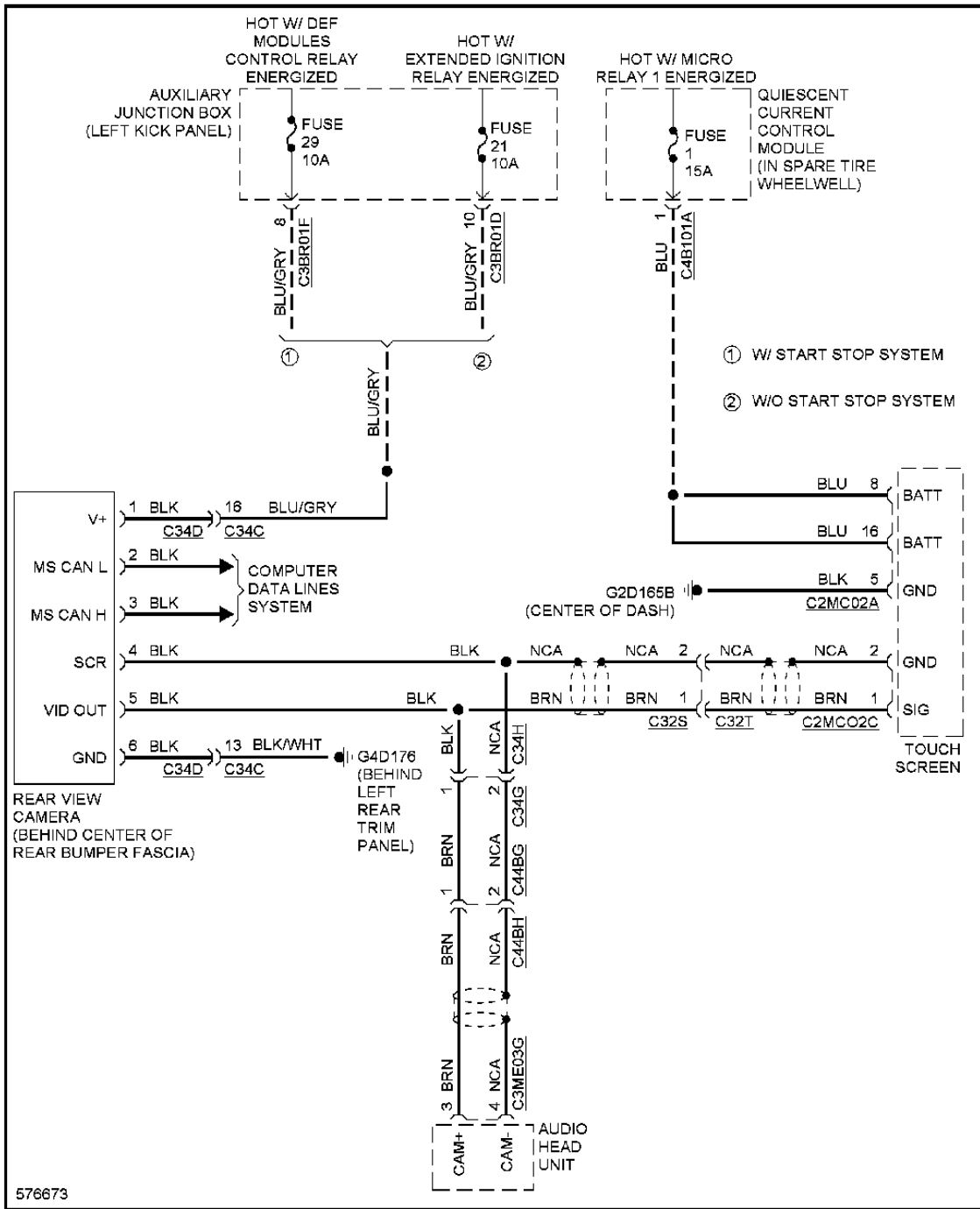


**Fig. 83: Navigation Circuit, W/O Control Touch (6 of 6)**

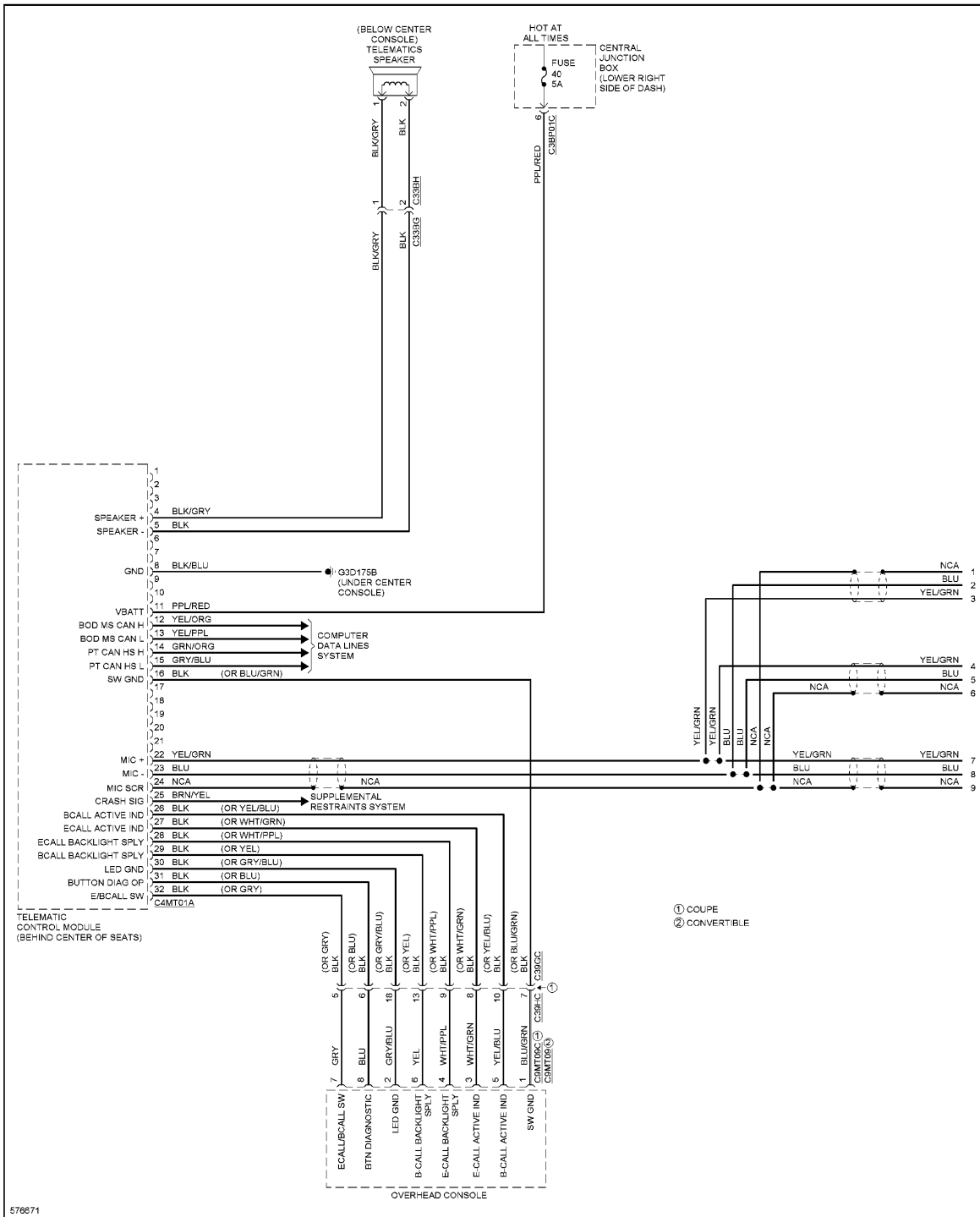


**Fig. 84: Parking Assistant Circuit**

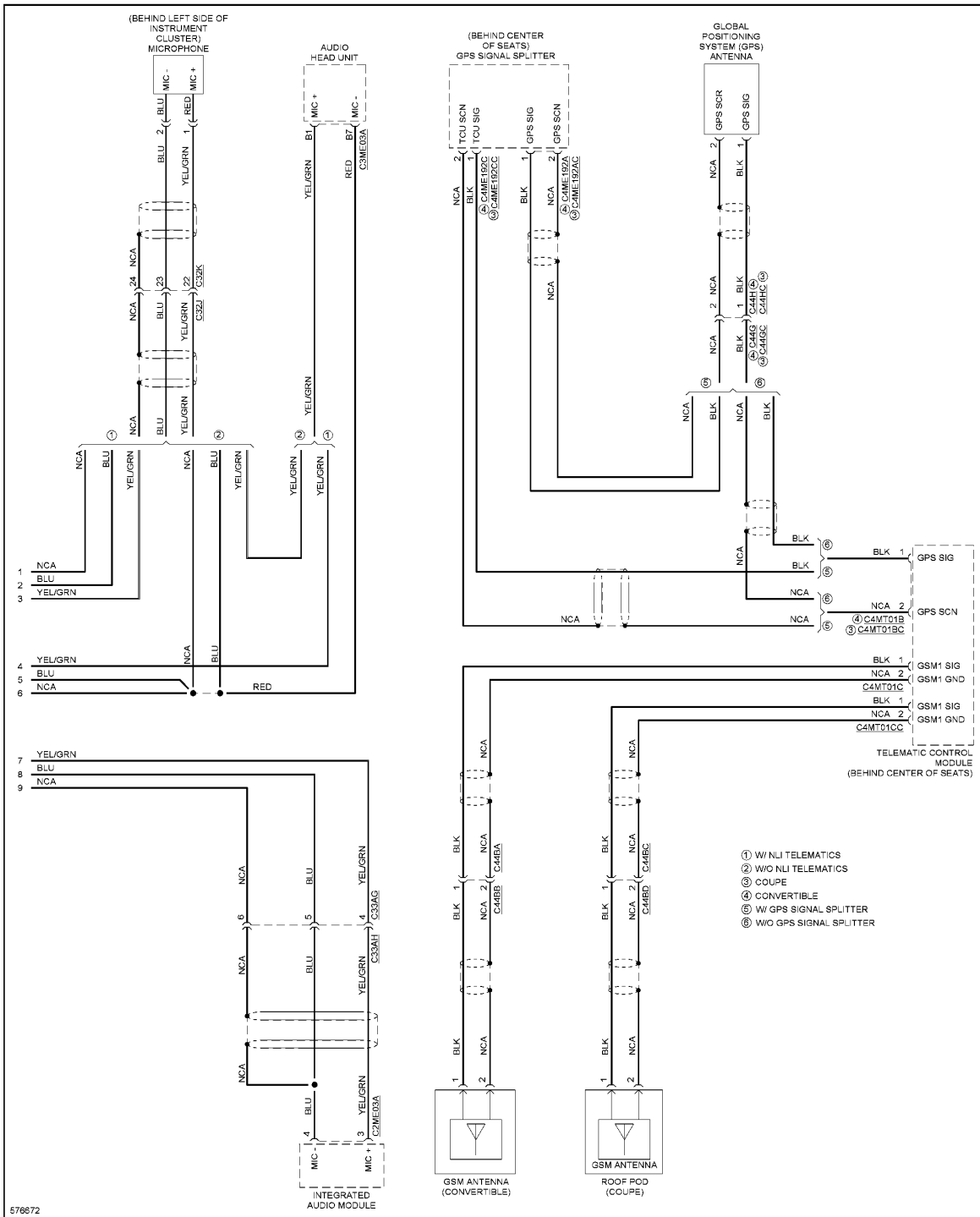




**Fig. 85: Rear View Camera Circuit**

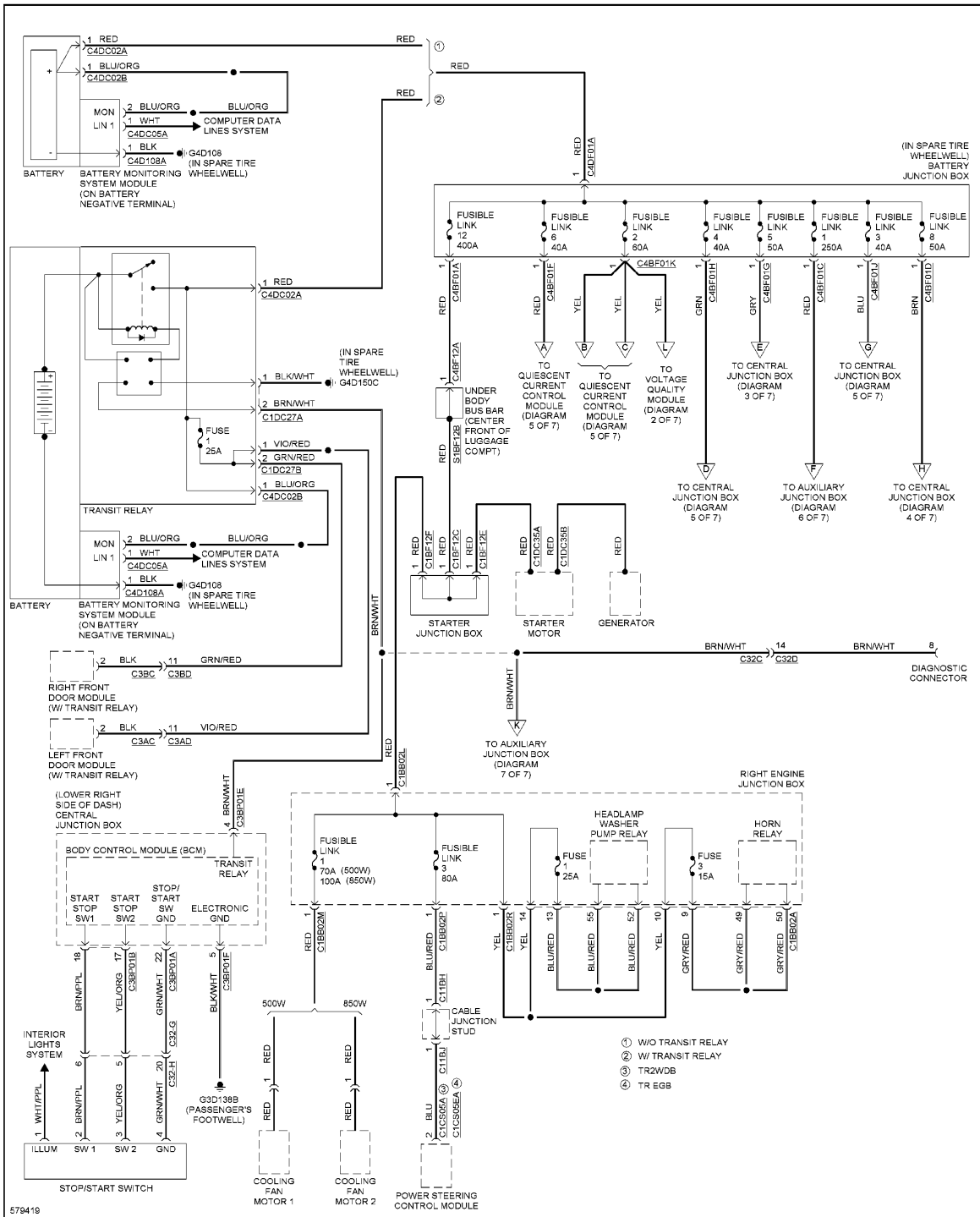


**Fig. 86: Telematics Circuit (1 of 2)**

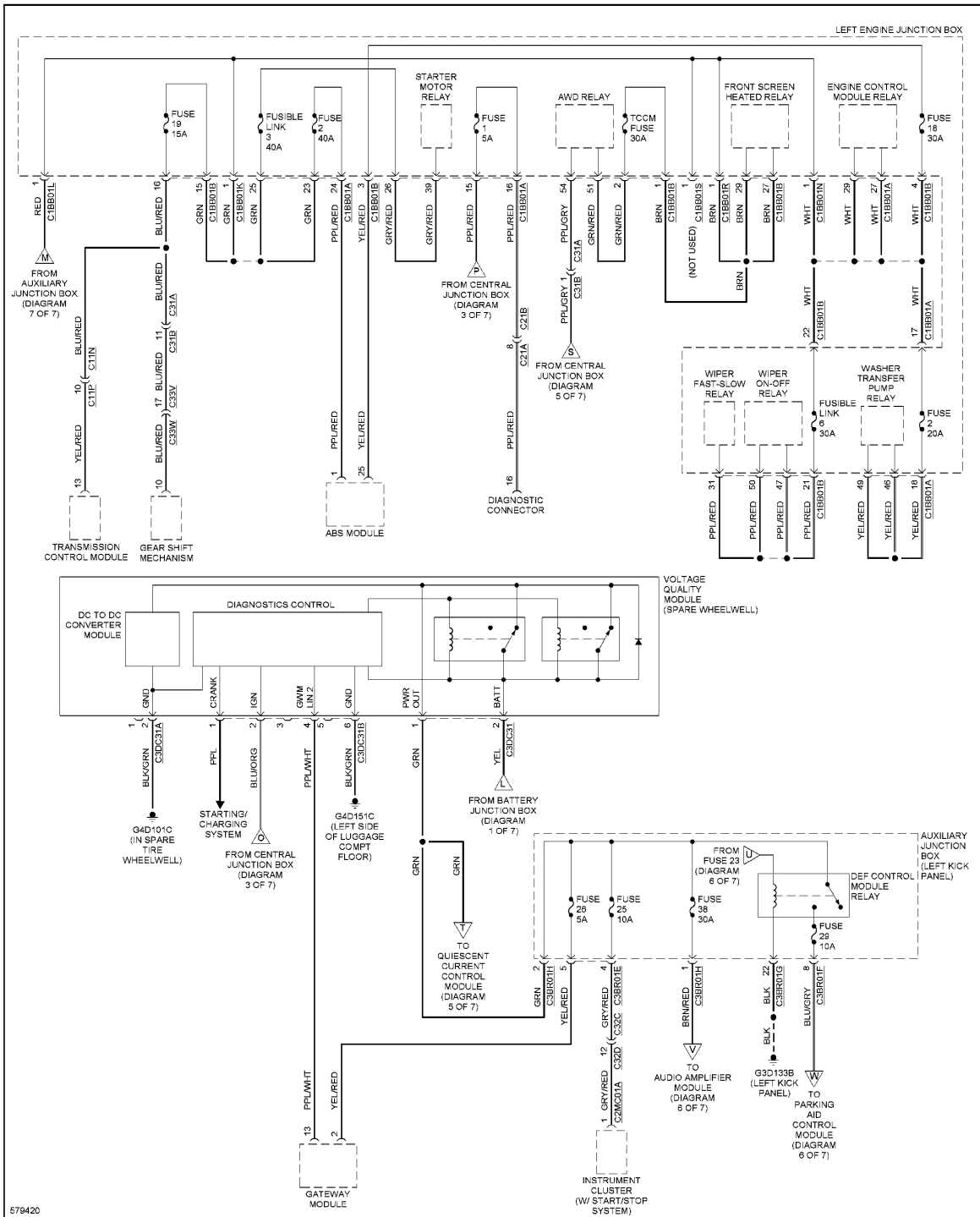


**Fig. 87: Telematics Circuit (2 of 2)**

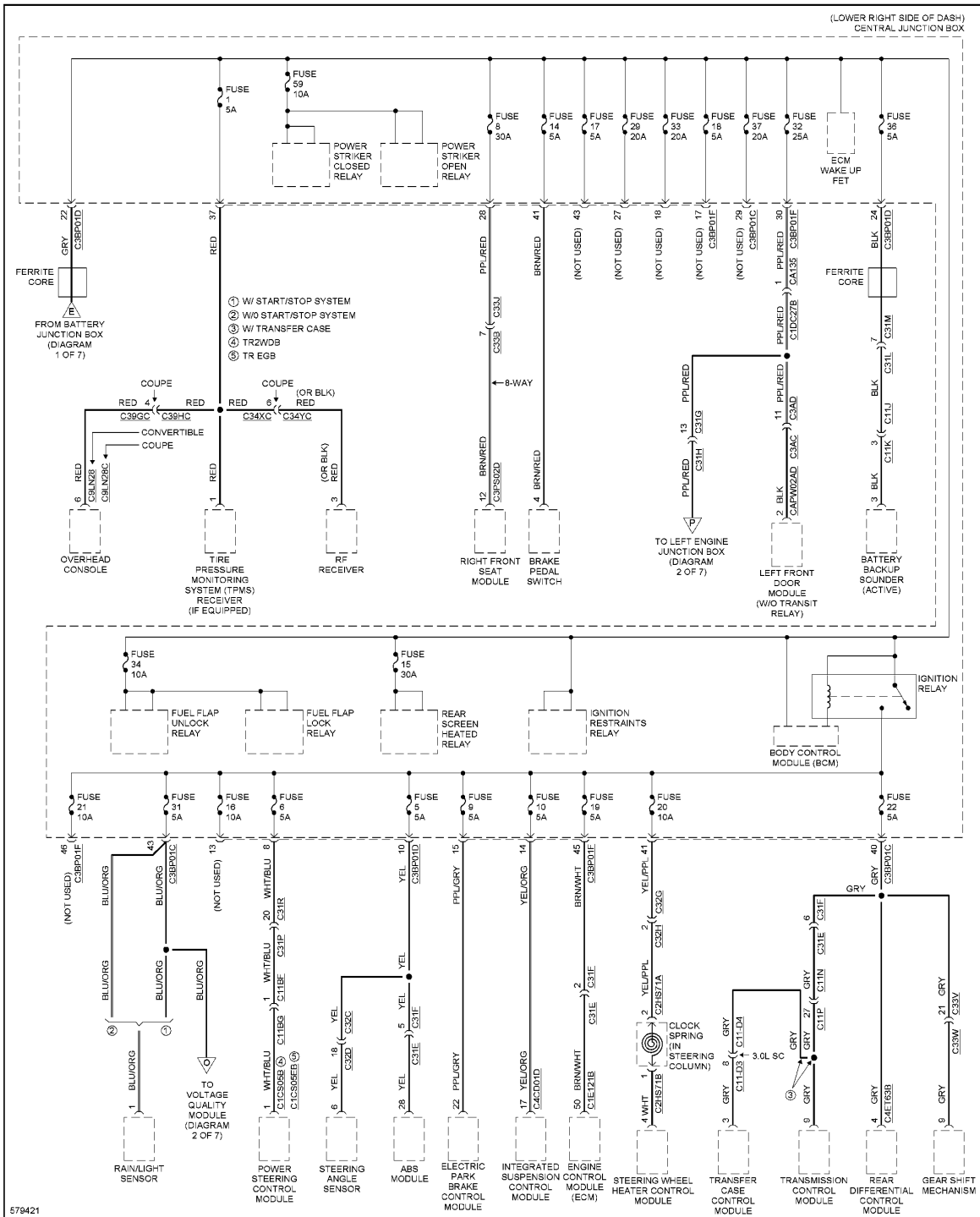
**POWER DISTRIBUTION**



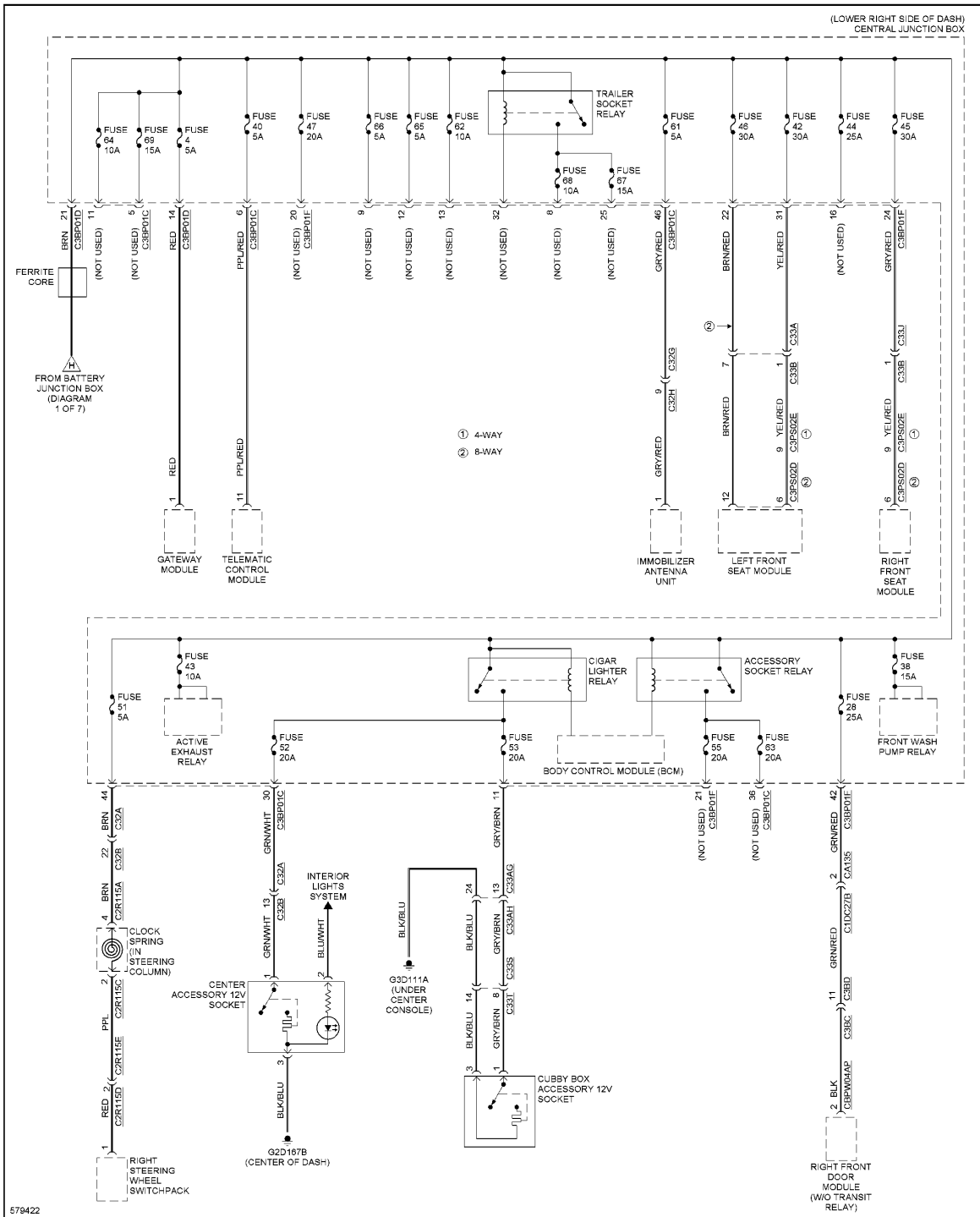
**Fig. 88: Power Distribution Circuit (1 of 7)**



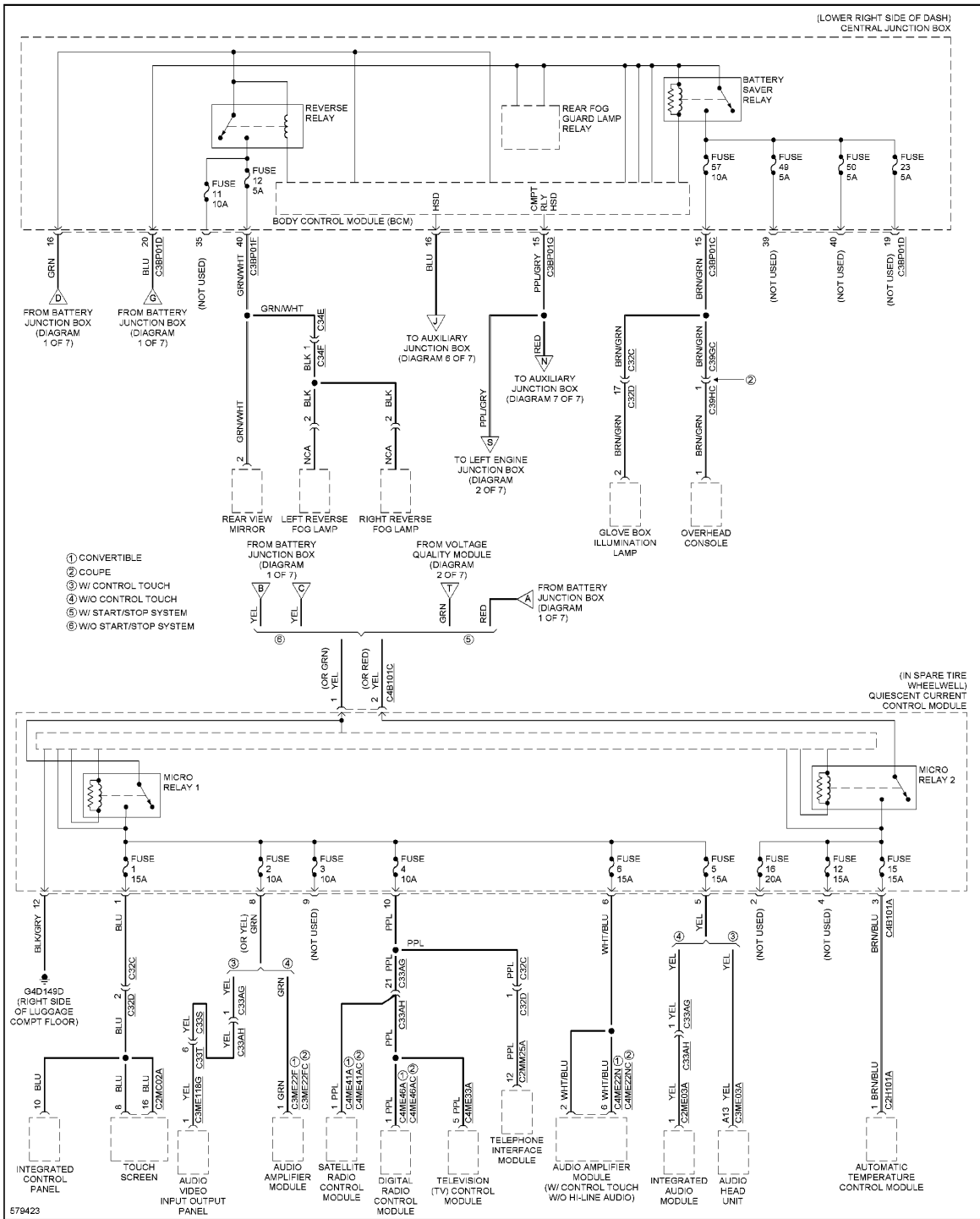
**Fig. 89: Power Distribution Circuit (2 of 7)**



**Fig. 90: Power Distribution Circuit (3 of 7)**



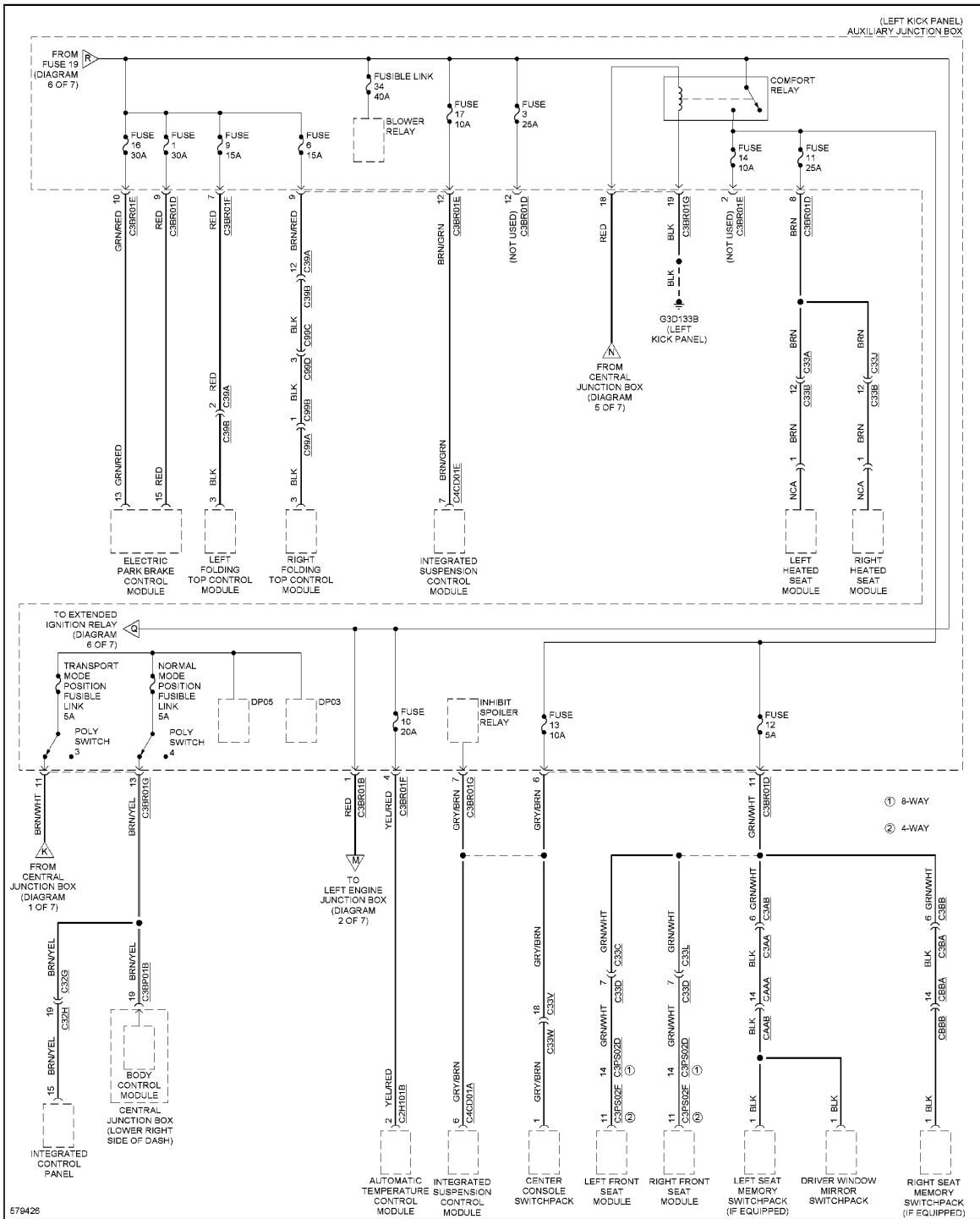
**Fig. 91: Power Distribution Circuit (4 of 7)**



**Fig. 92: Power Distribution Circuit (5 of 7)**



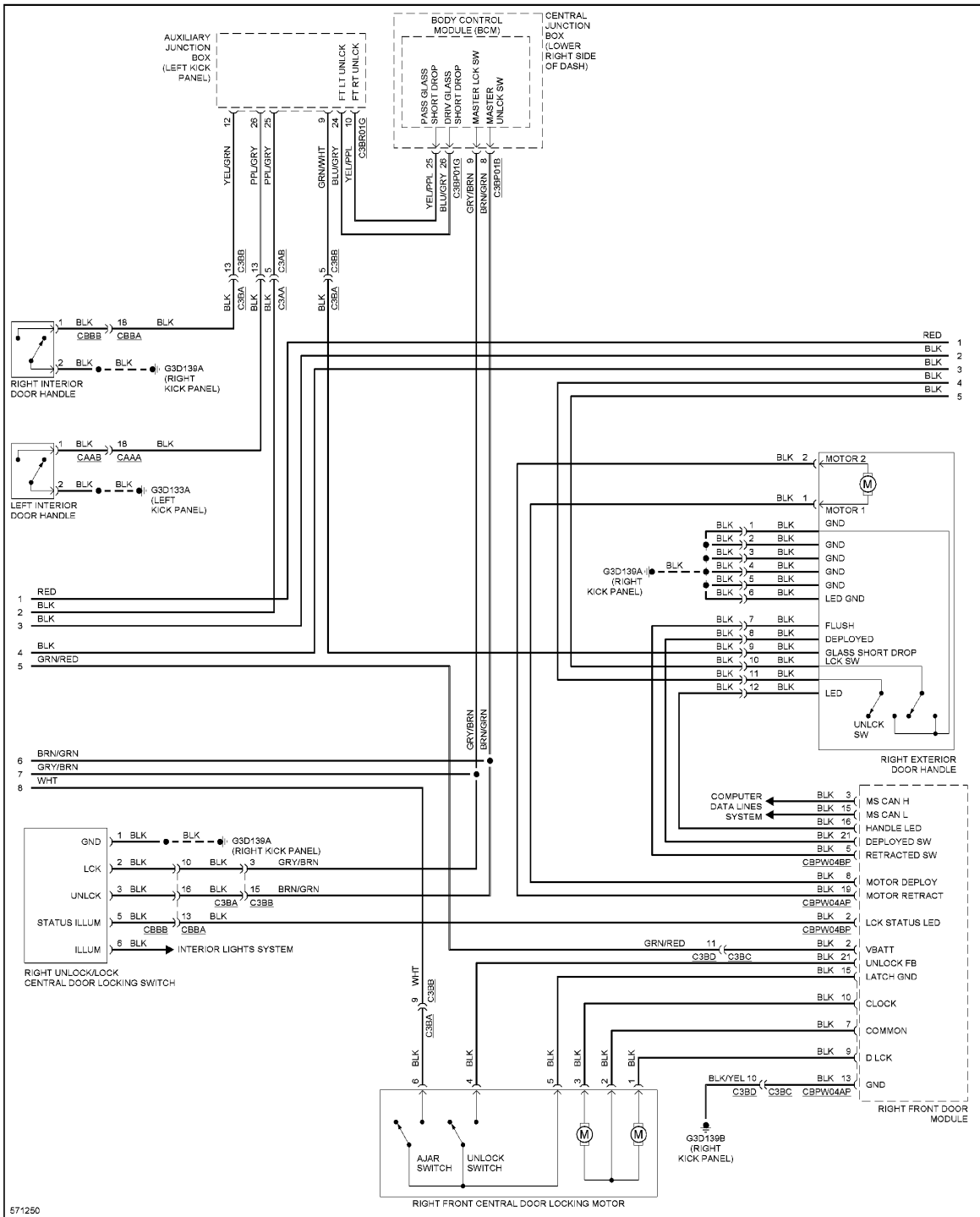




**Fig. 94: Power Distribution Circuit (7 of 7)**

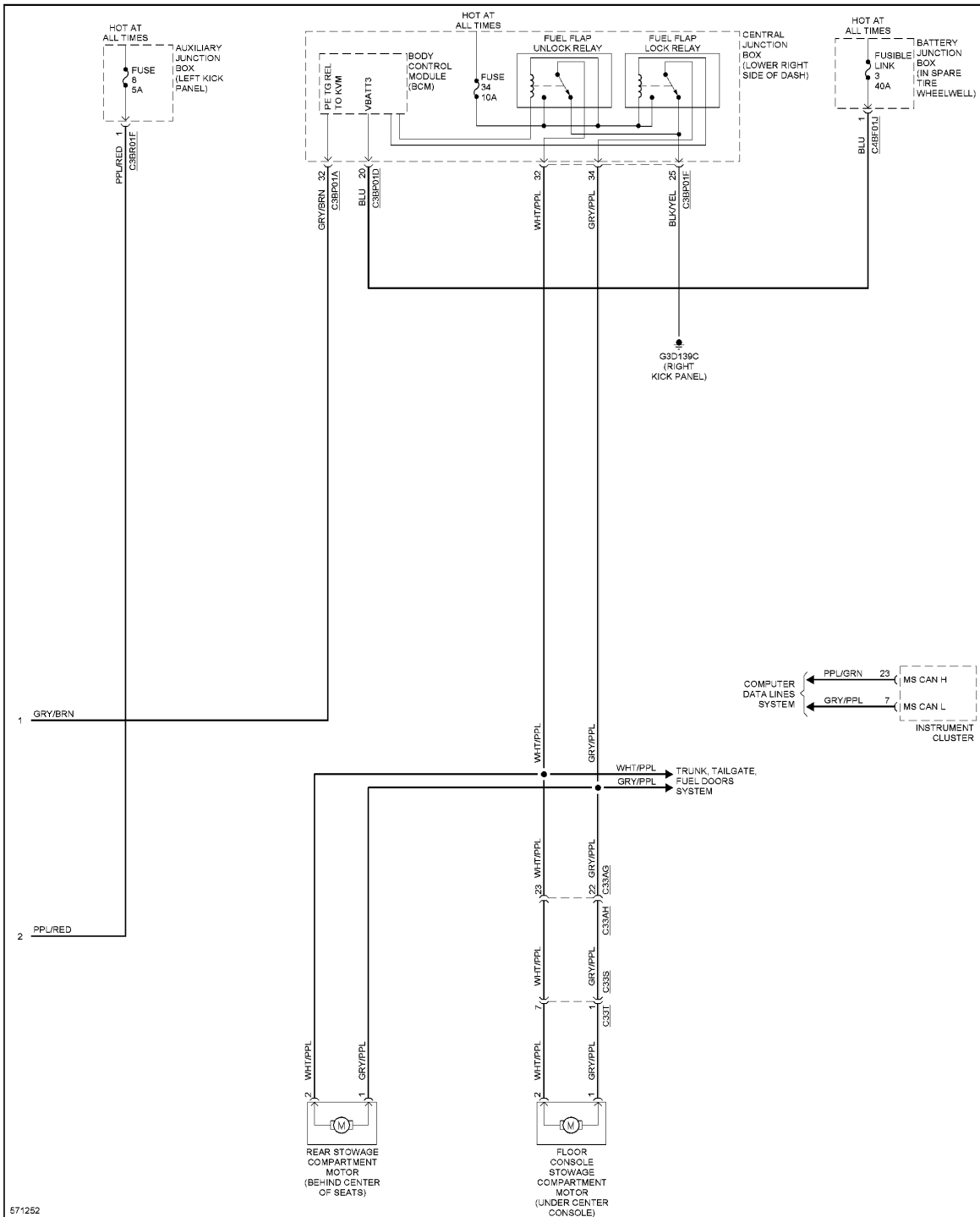
## POWER DOOR LOCKS





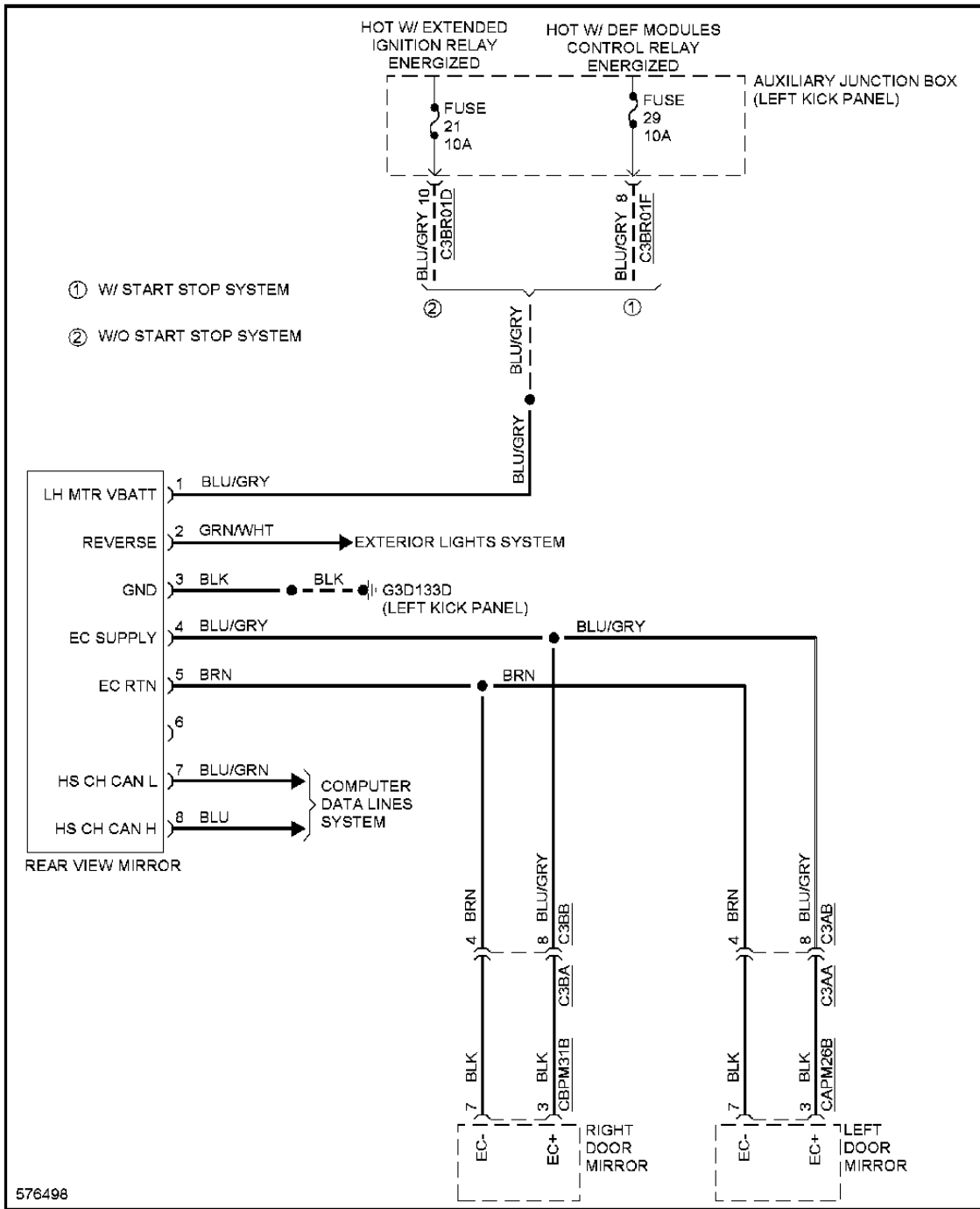
**Fig. 96: Power Door Locks Circuit (2 of 4)**



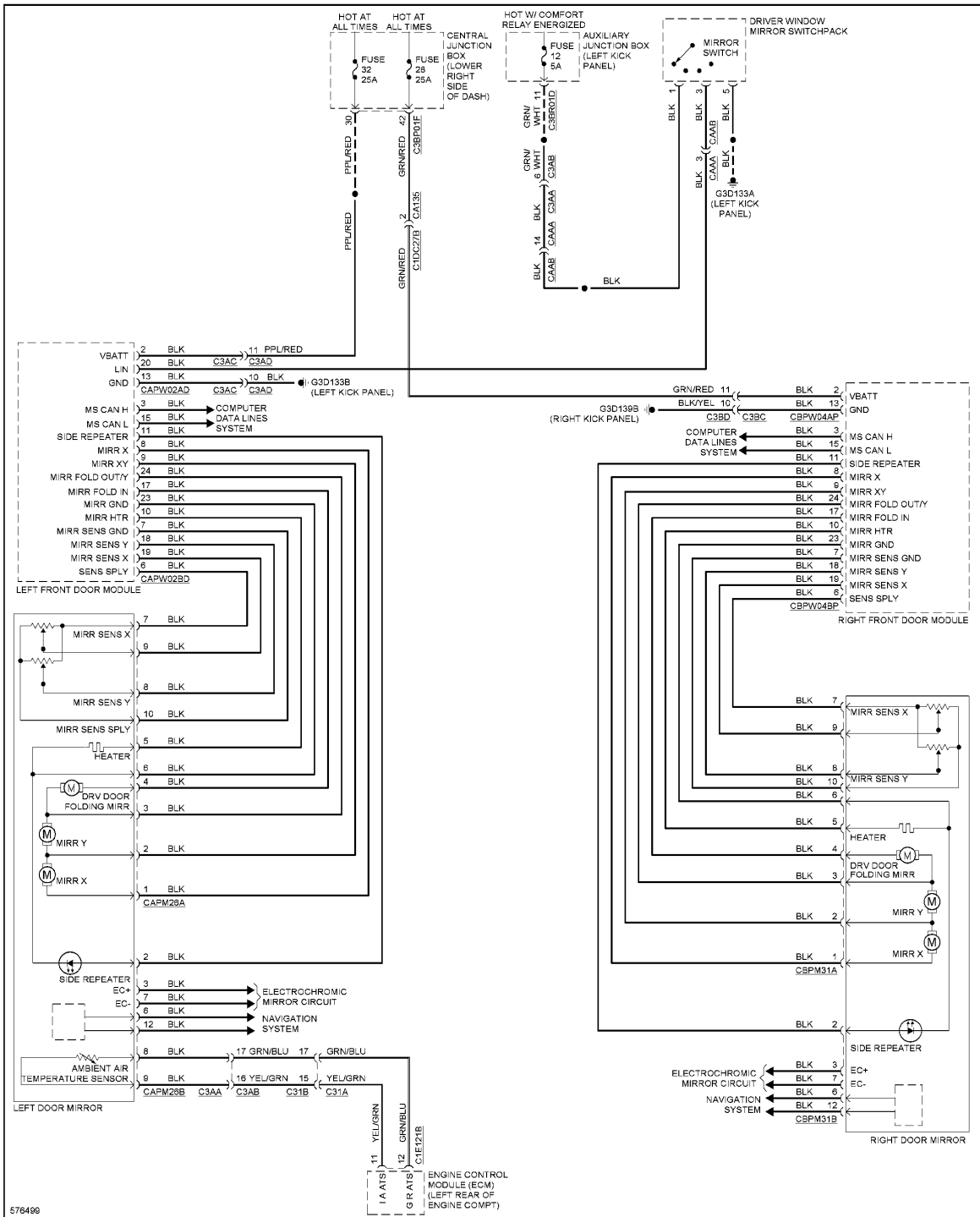


**Fig. 98: Power Door Locks Circuit (4 of 4)**

## POWER MIRRORS



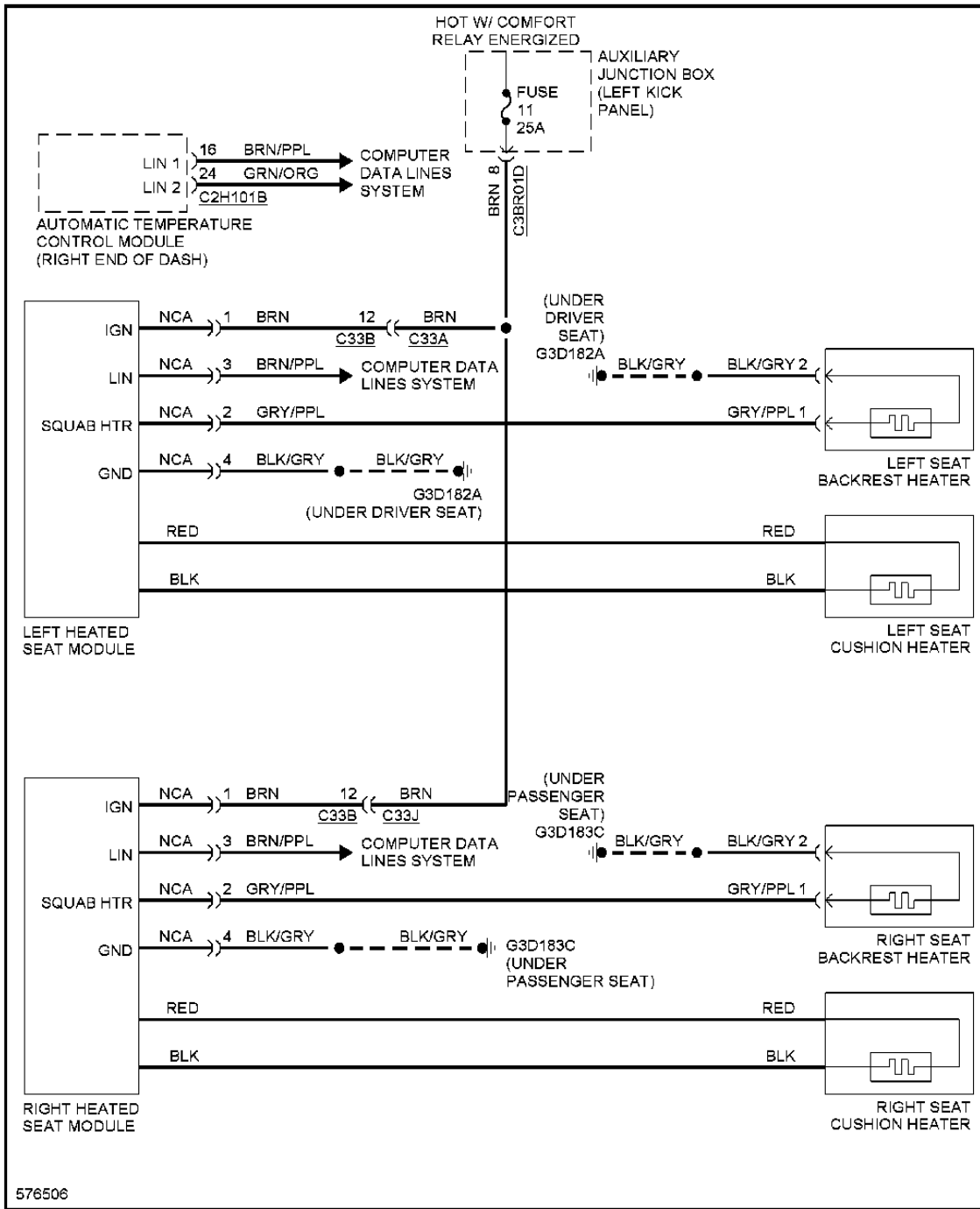
**Fig. 99: Electrochromic Mirror Circuit**



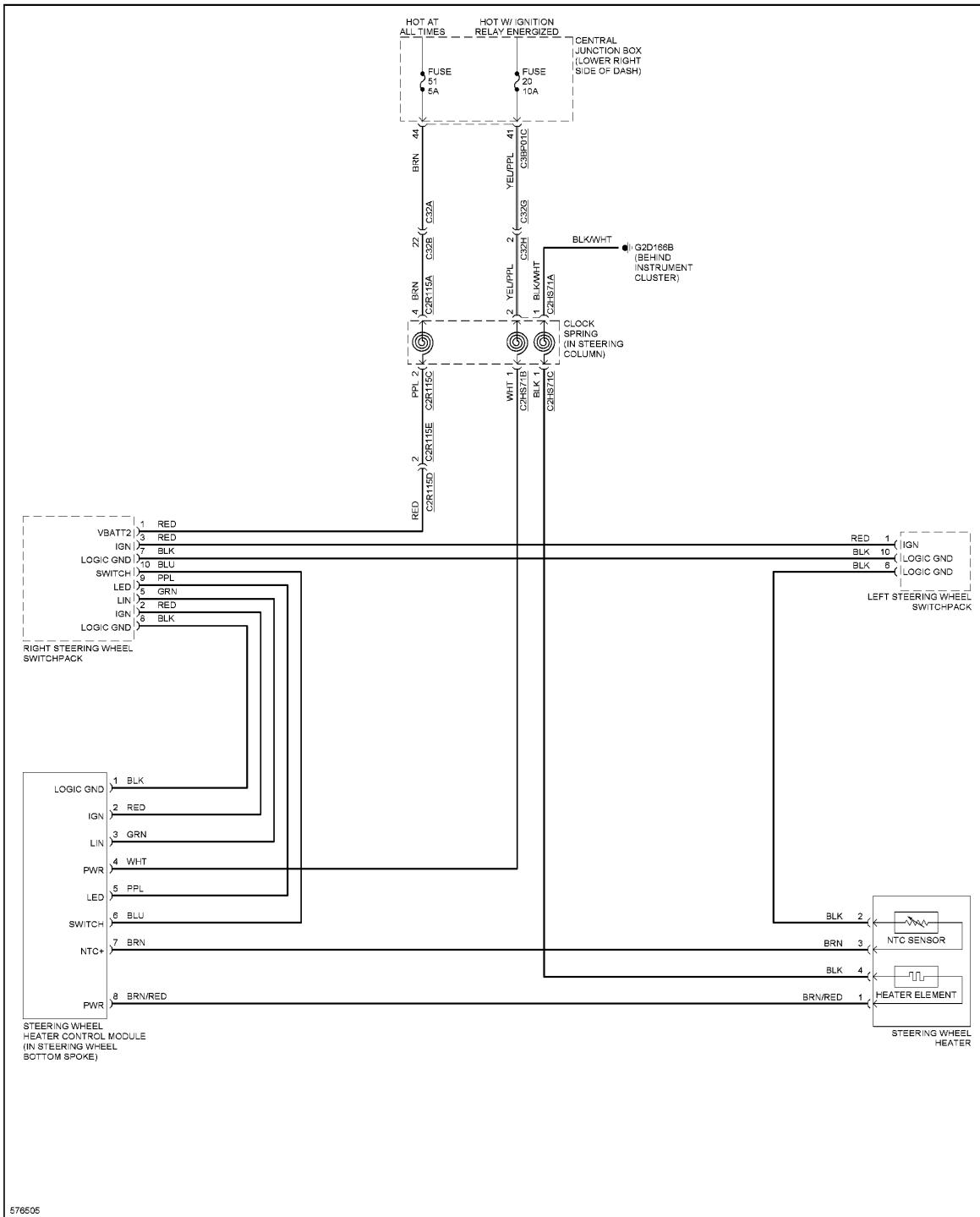
**Fig. 100: Power Mirrors Circuit**

## POWER SEATS



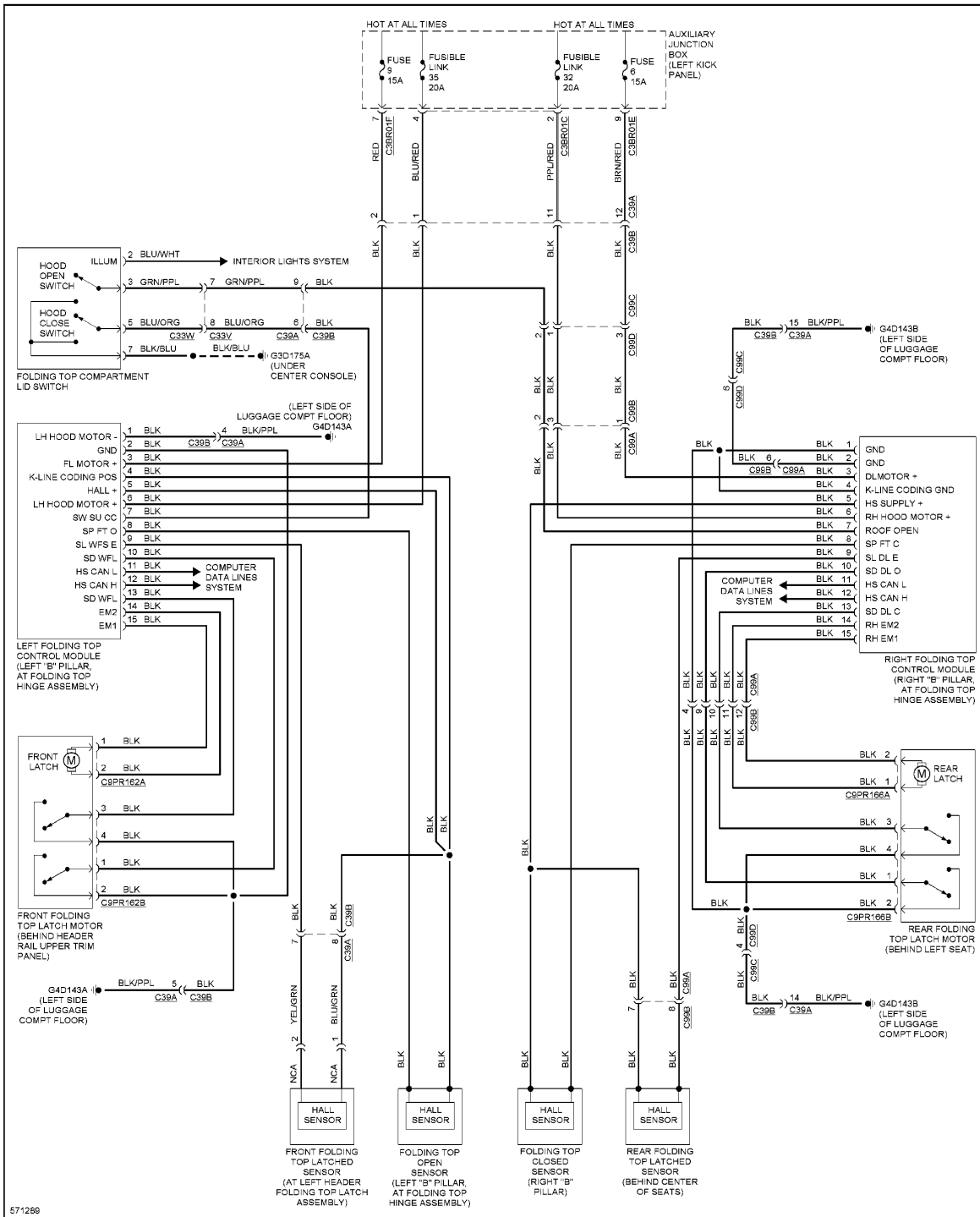


**Fig. 101: Heated Seats Circuit**



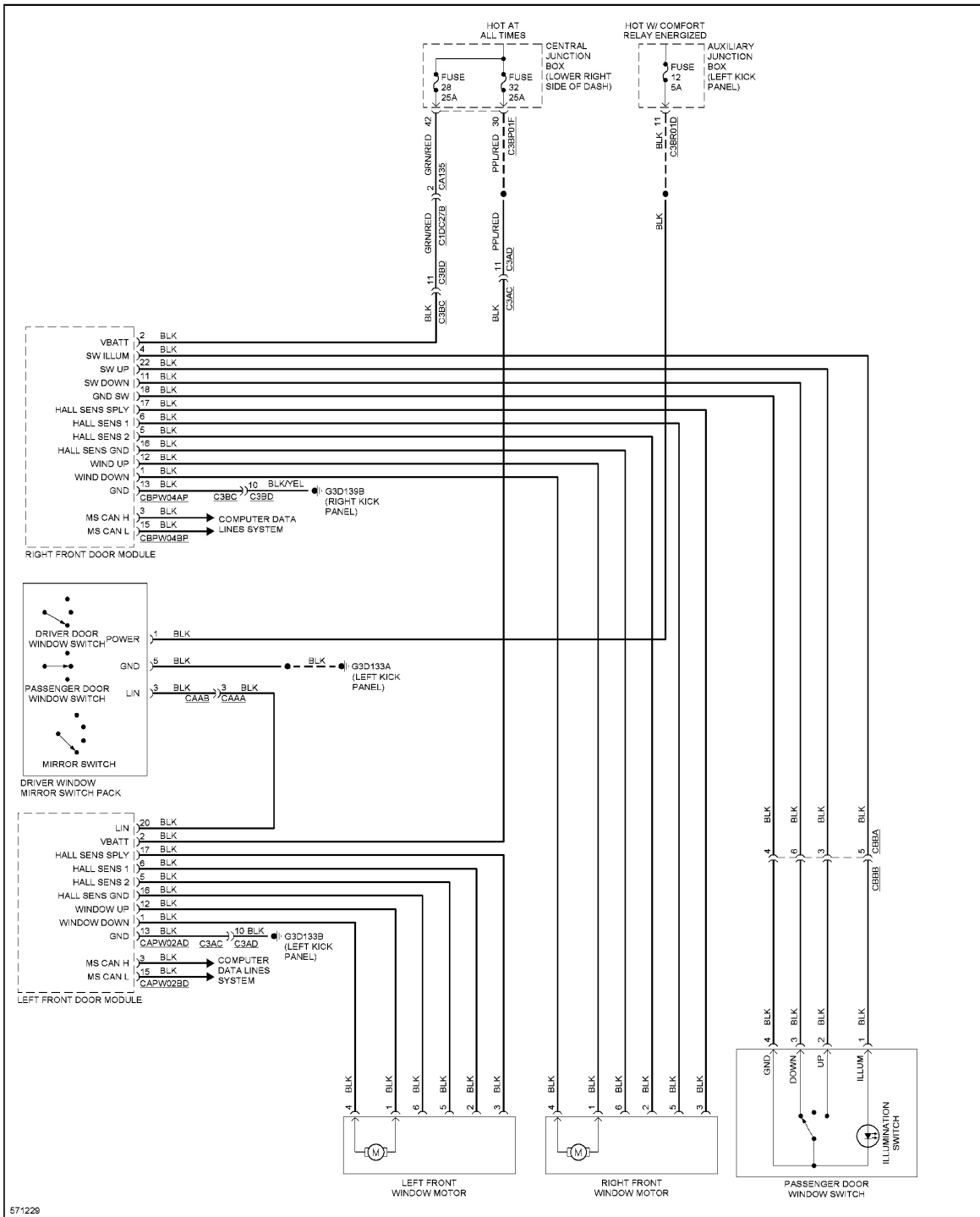
**Fig. 102: Heated Steering Wheel Circuit**

**POWER TOP/SUNROOF**



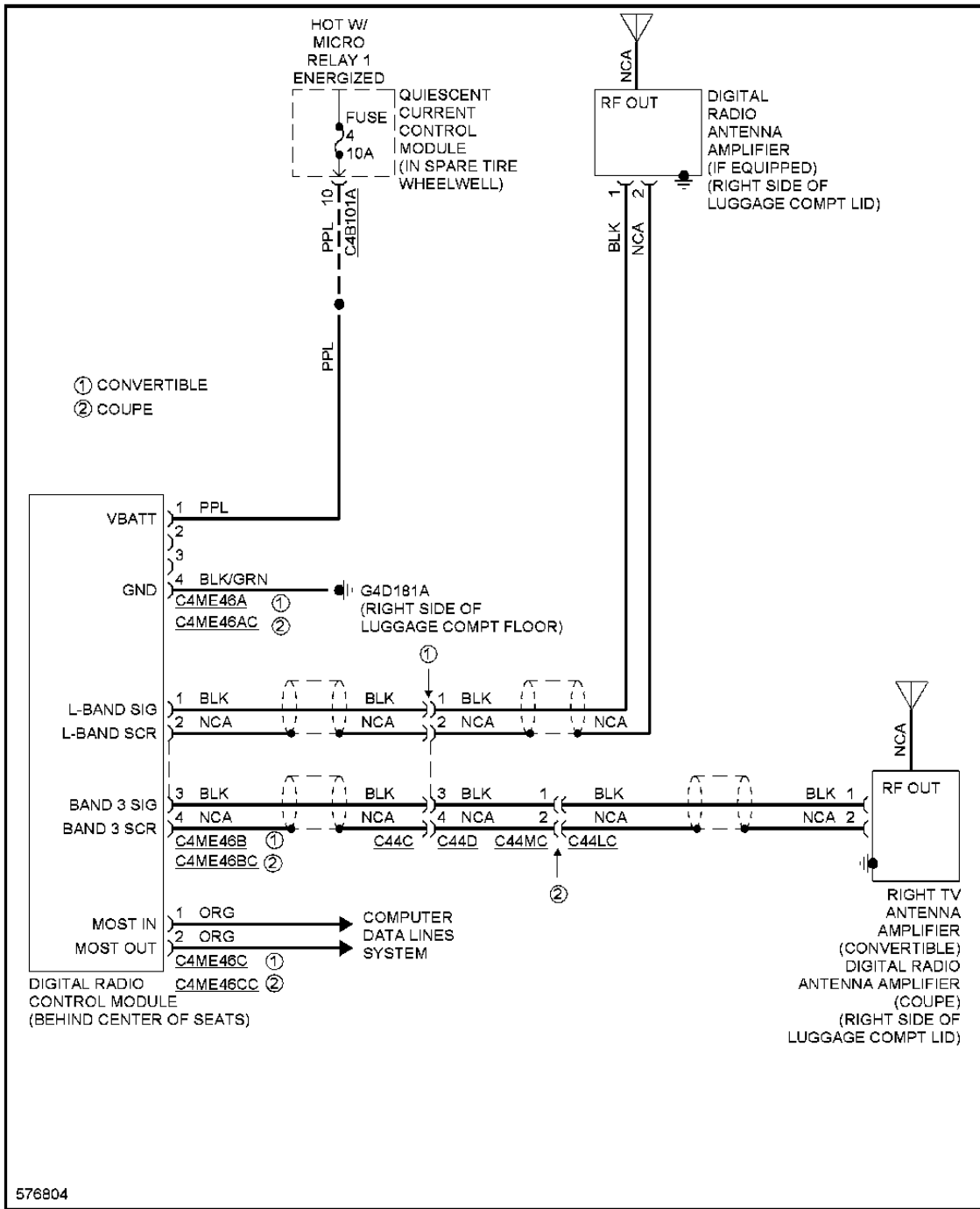
**Fig. 103: Power Top/Sunroof Circuit**

**POWER WINDOWS**



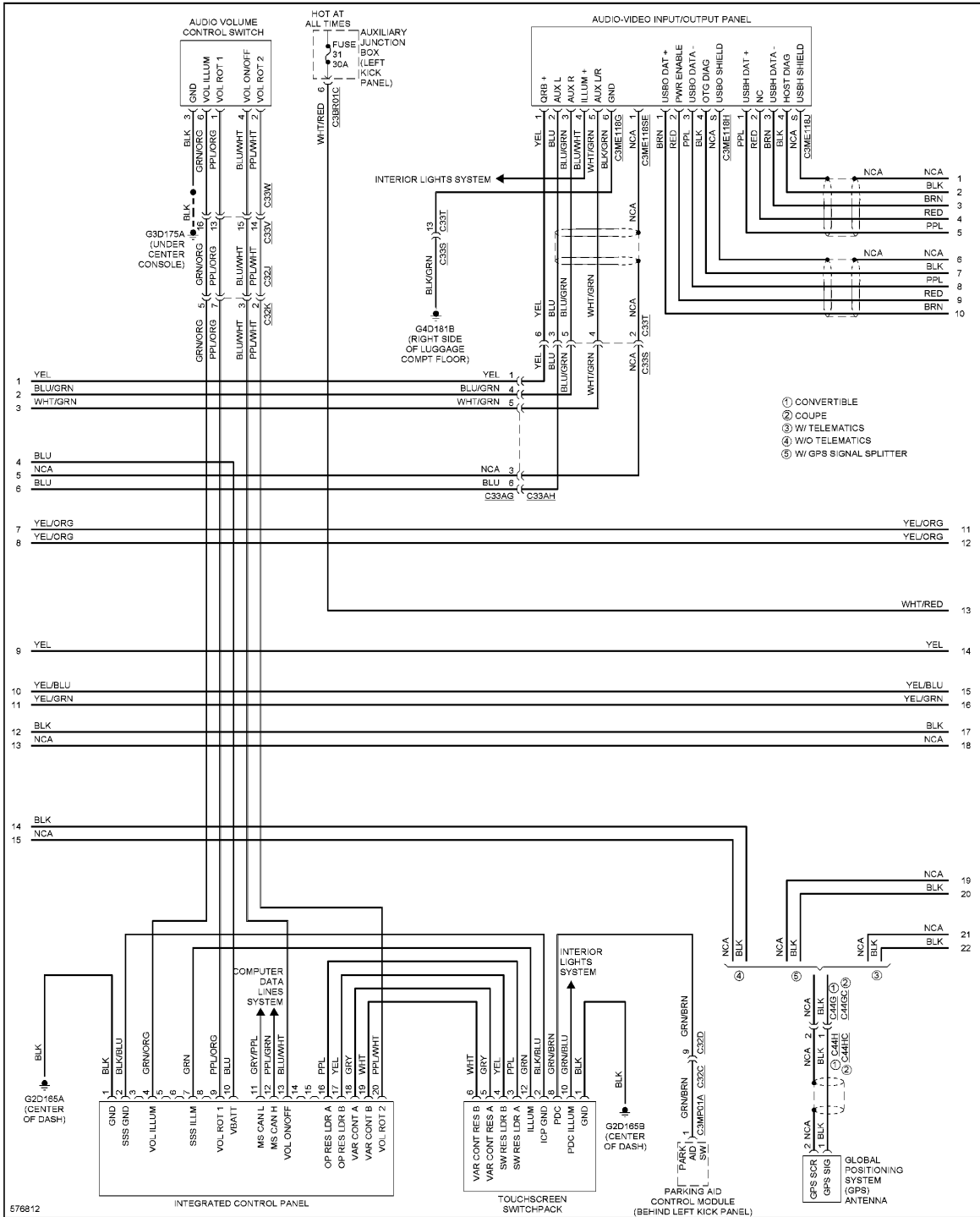
**Fig. 104: Power Windows Circuit**

**RADIO**

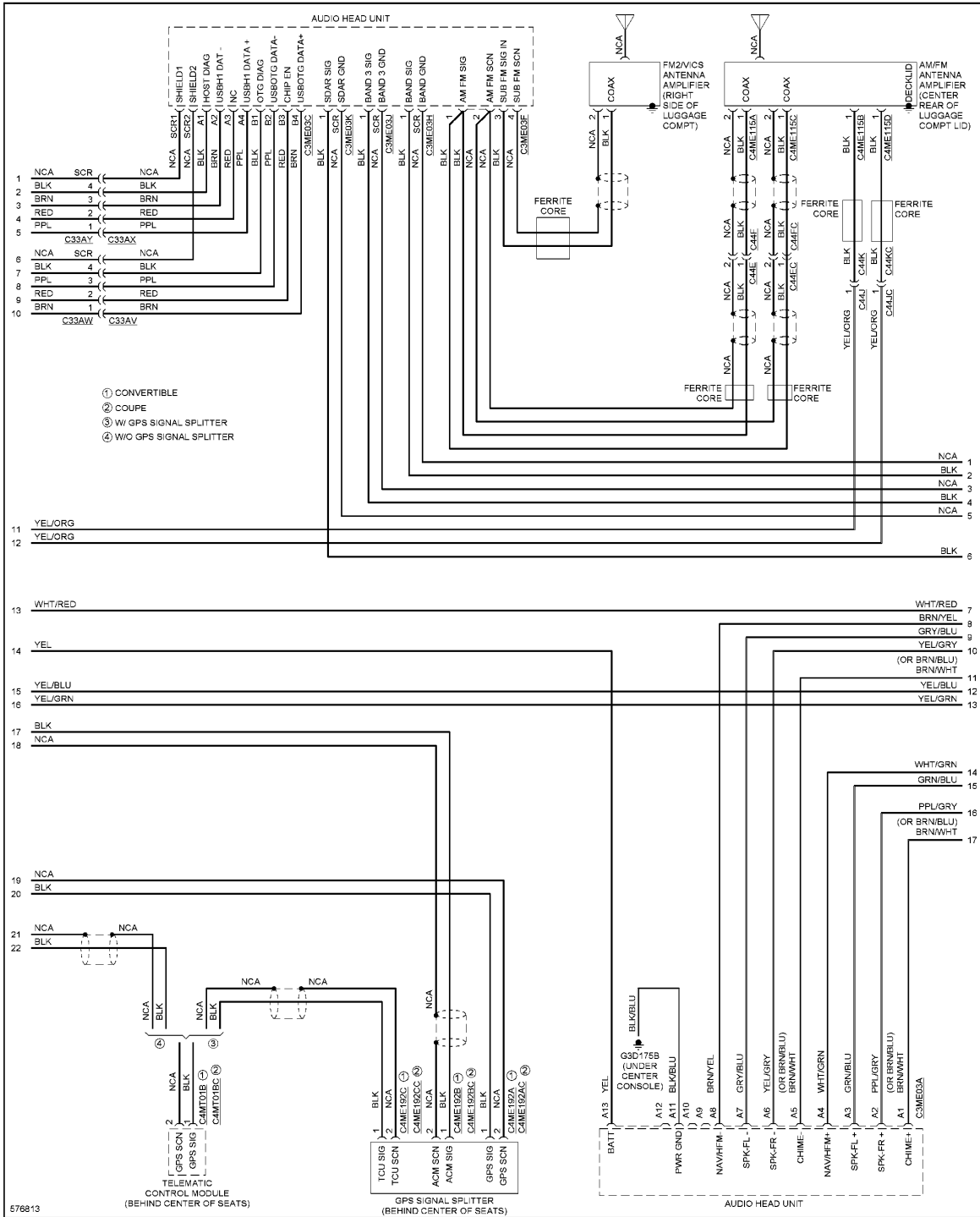


**Fig. 105: Digital Radio Circuit**



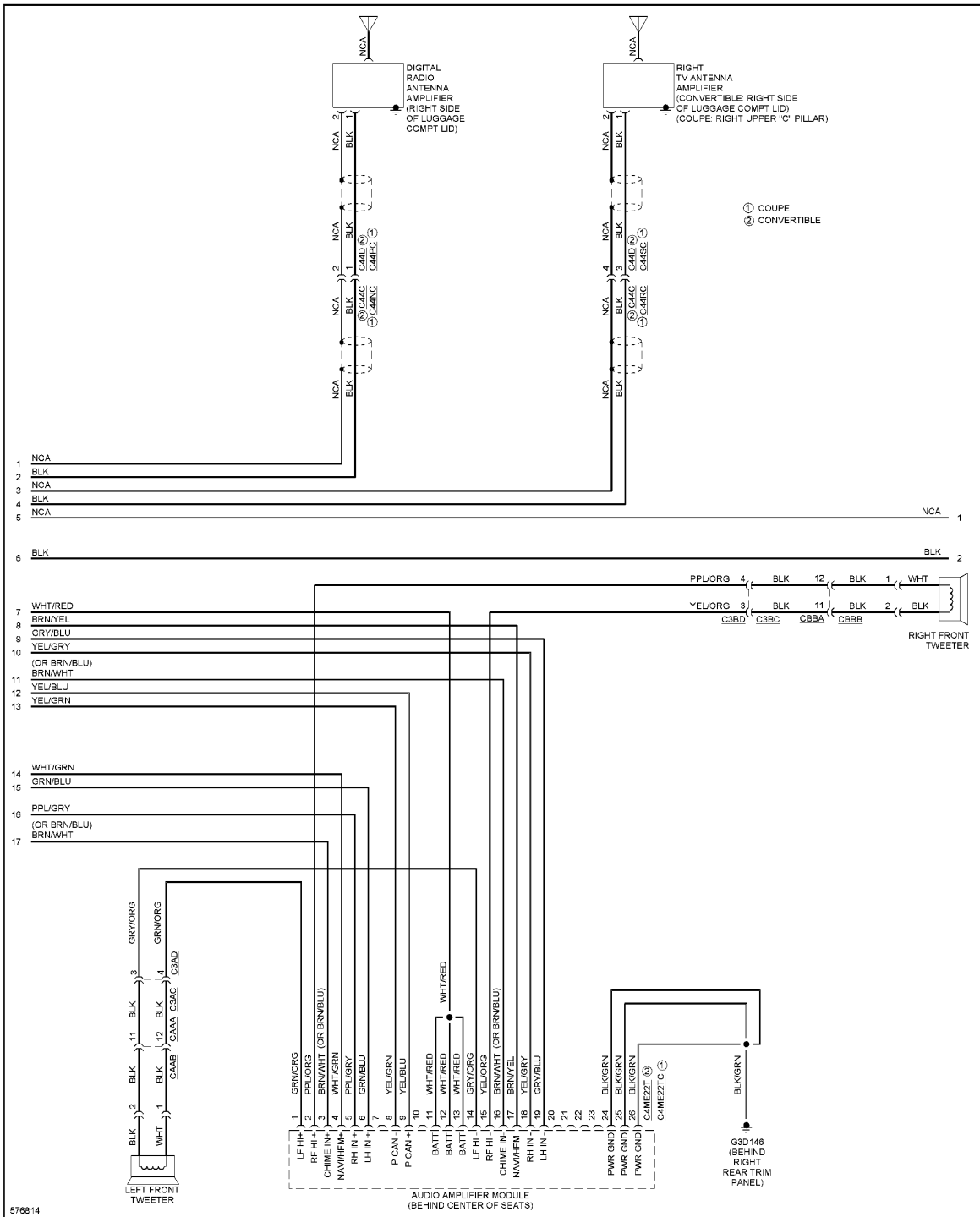


**Fig. 107: Premium Radio Circuit, W/ Control Touch & Hi-line Audio (2 of 5)**

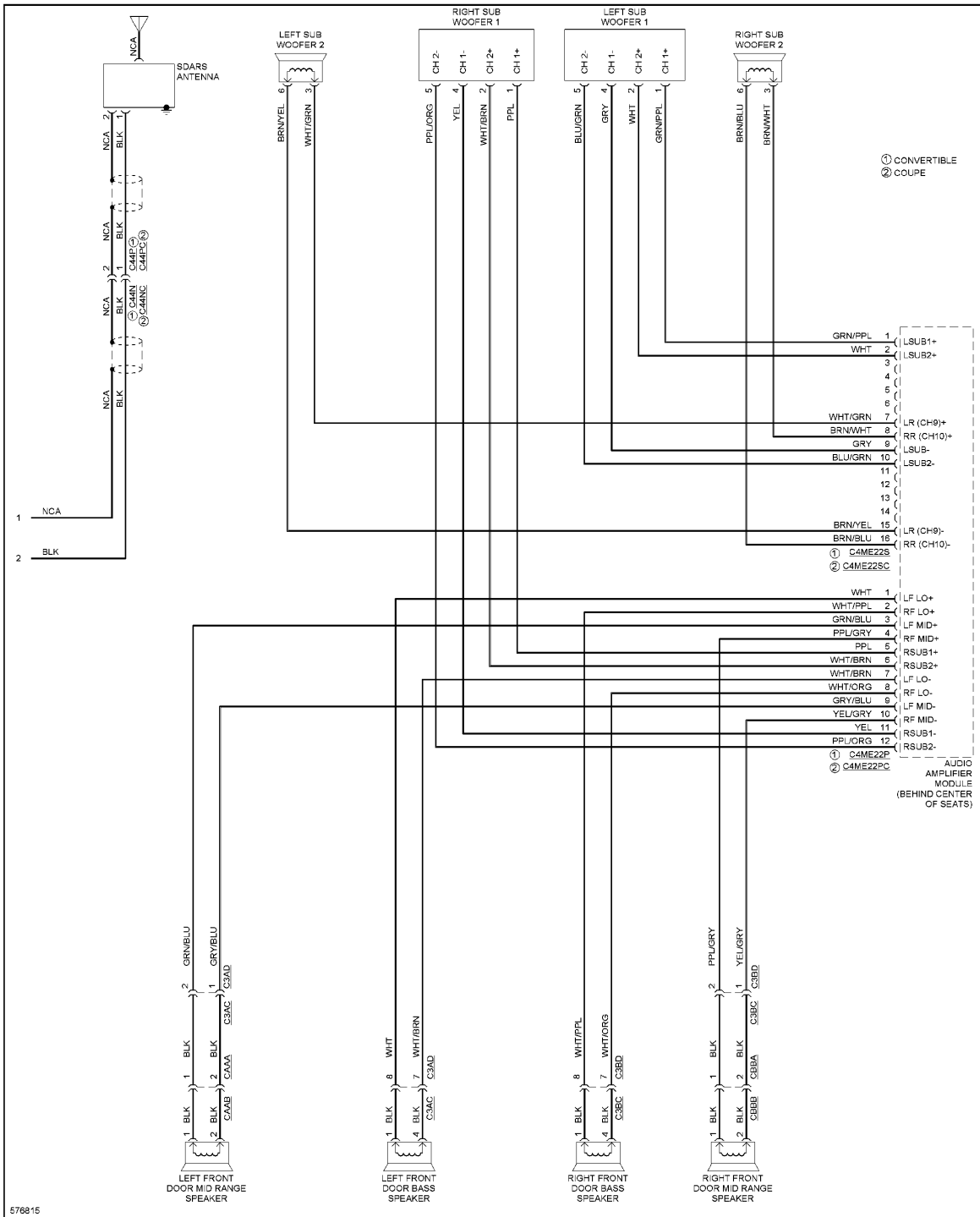


**Fig. 108: Premium Radio Circuit, W/ Control Touch & Hi-line Audio (3 of 5)**

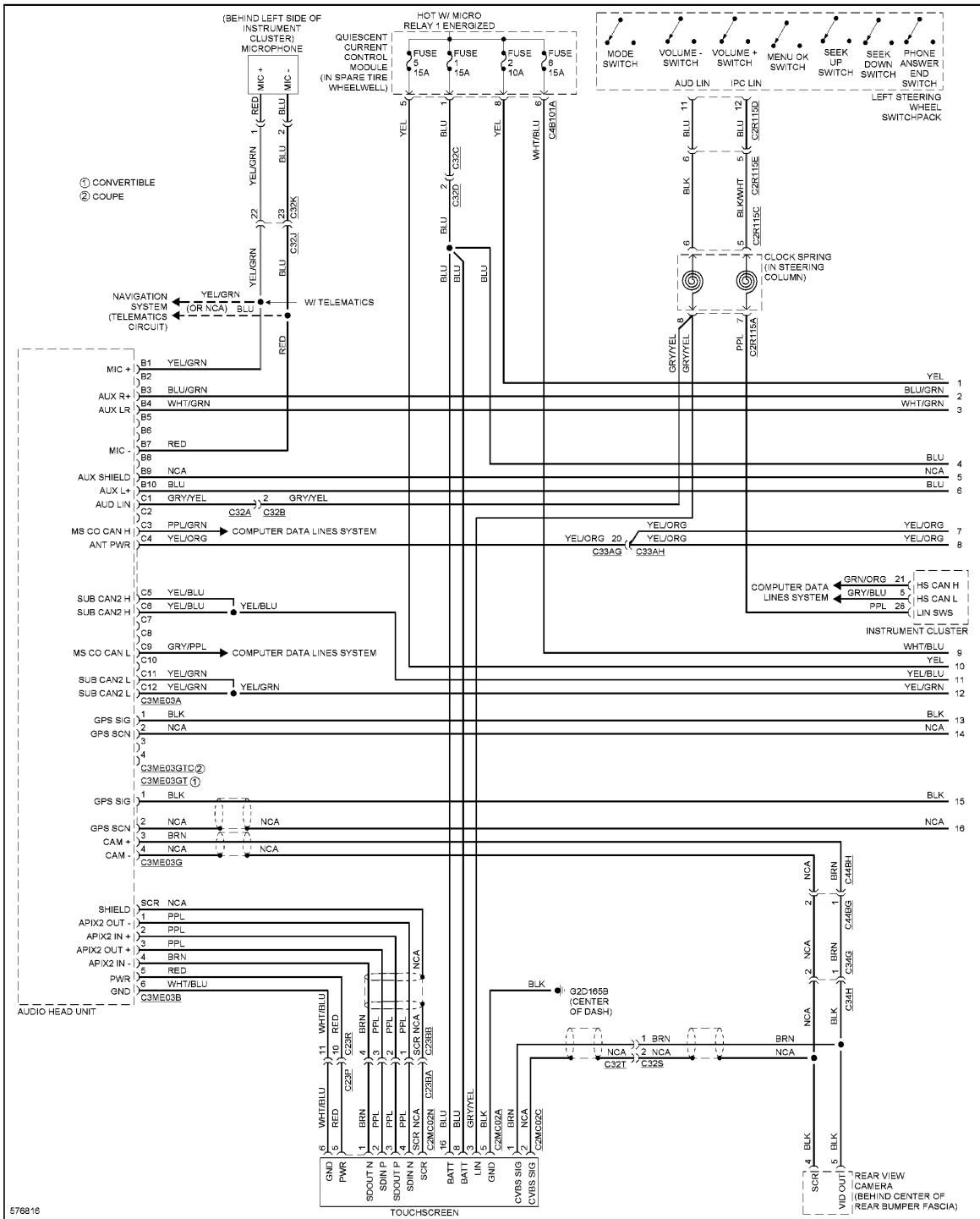




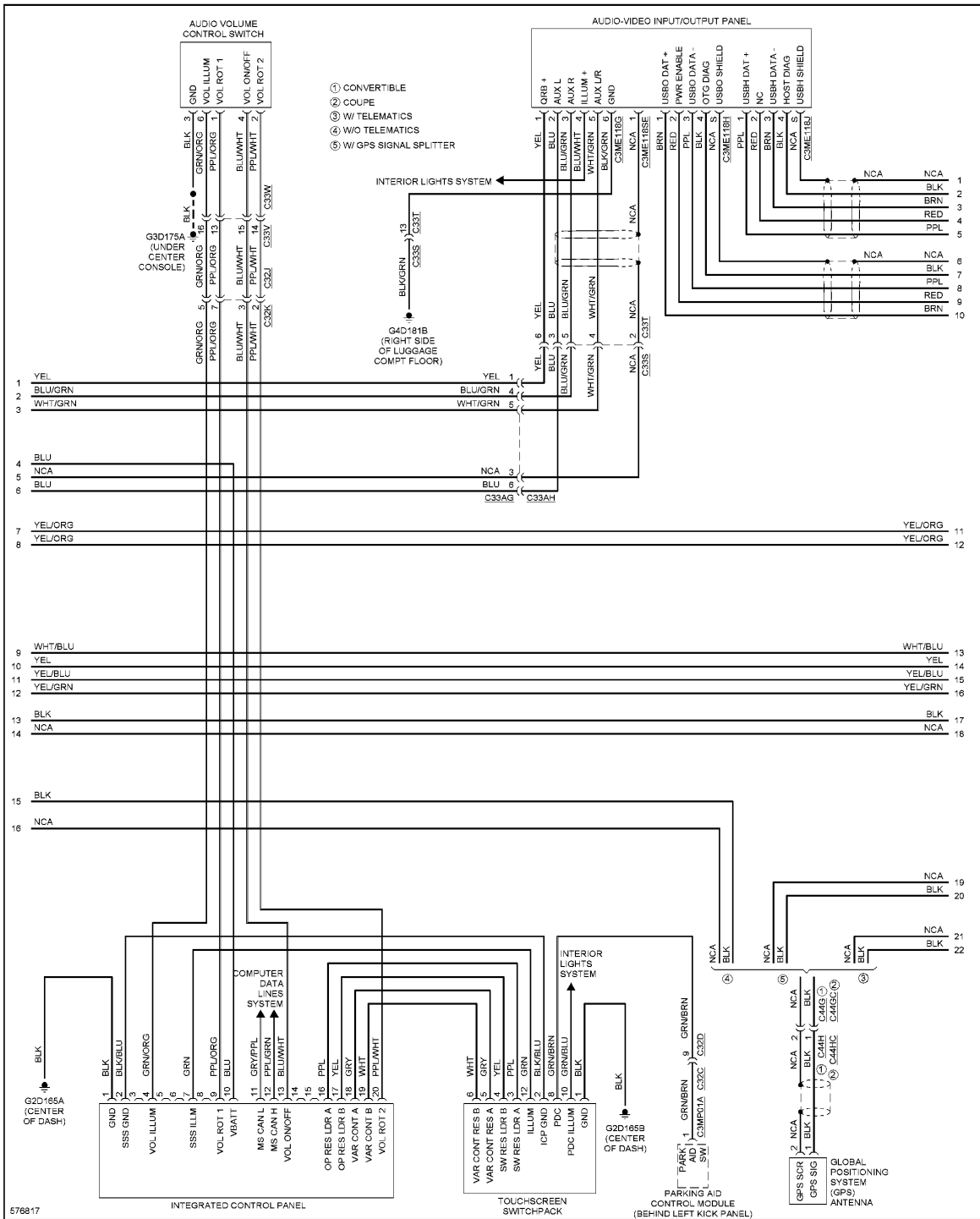
**Fig. 109: Premium Radio Circuit, W/ Control Touch & Hi-line Audio (4 of 5)**



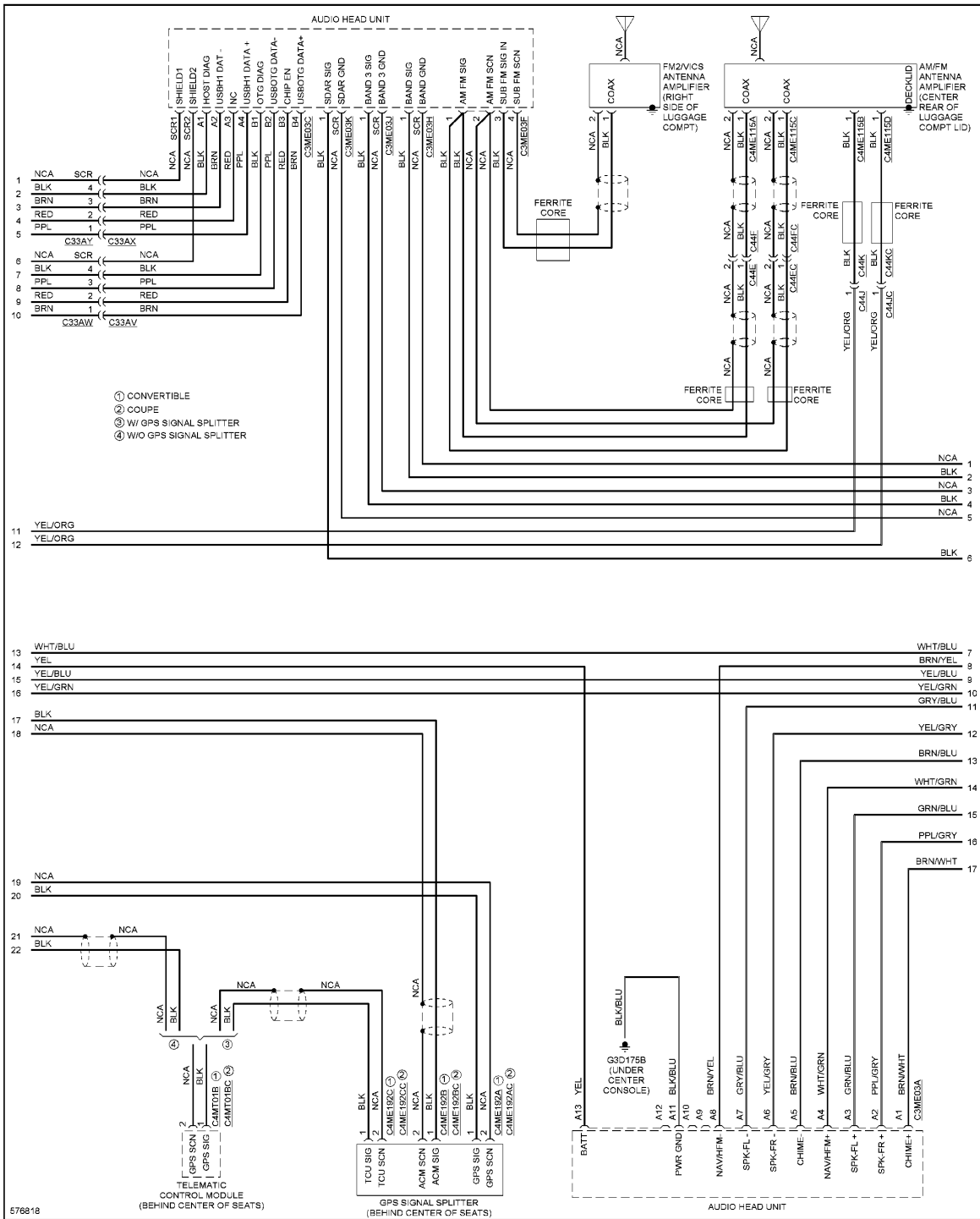
**Fig. 110: Premium Radio Circuit, W/ Control Touch & Hi-line Audio (5 of 5)**



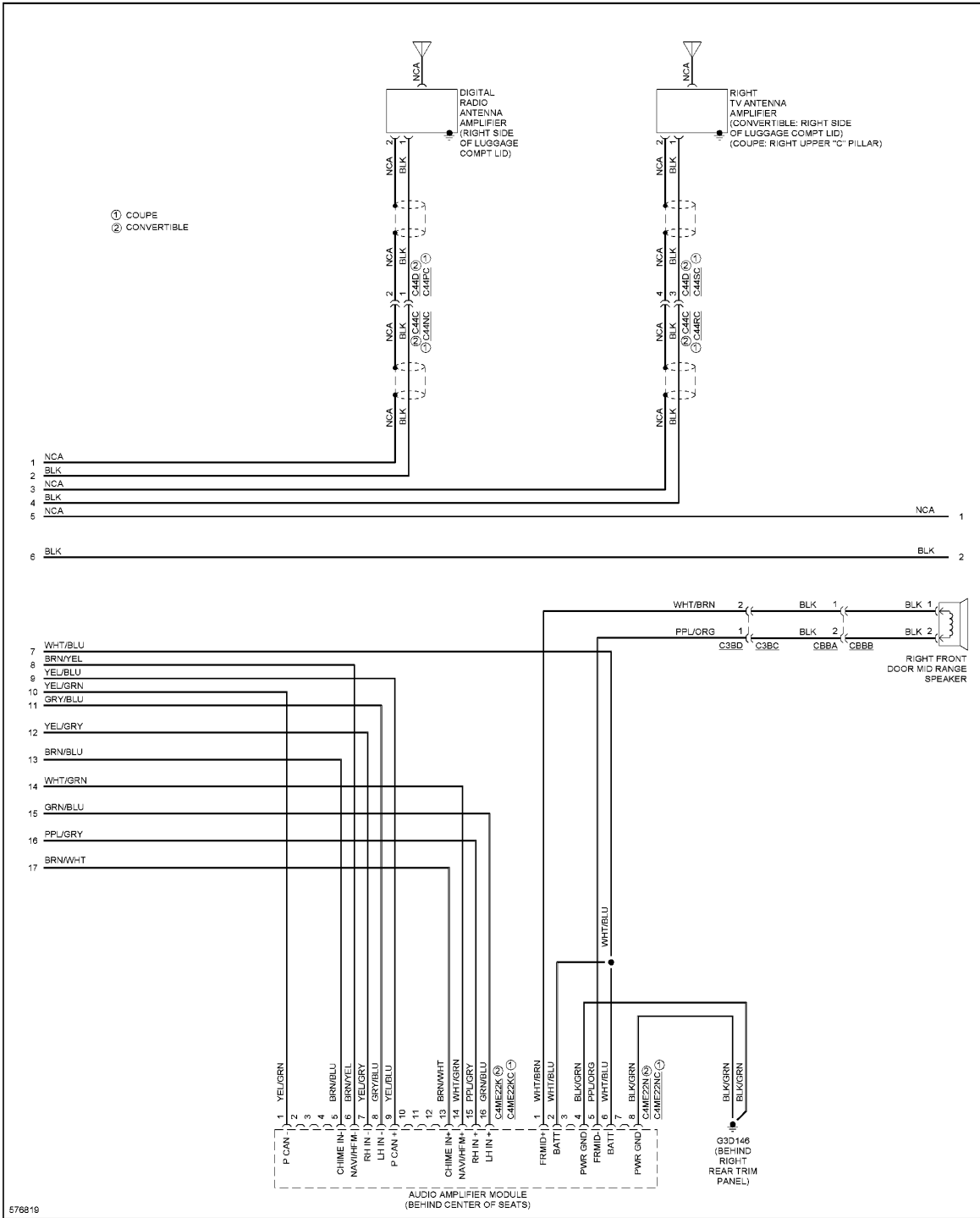
**Fig. 111: Premium Radio Circuit, W/ Control Touch W/O Hi-line Audio (1 of 5)**



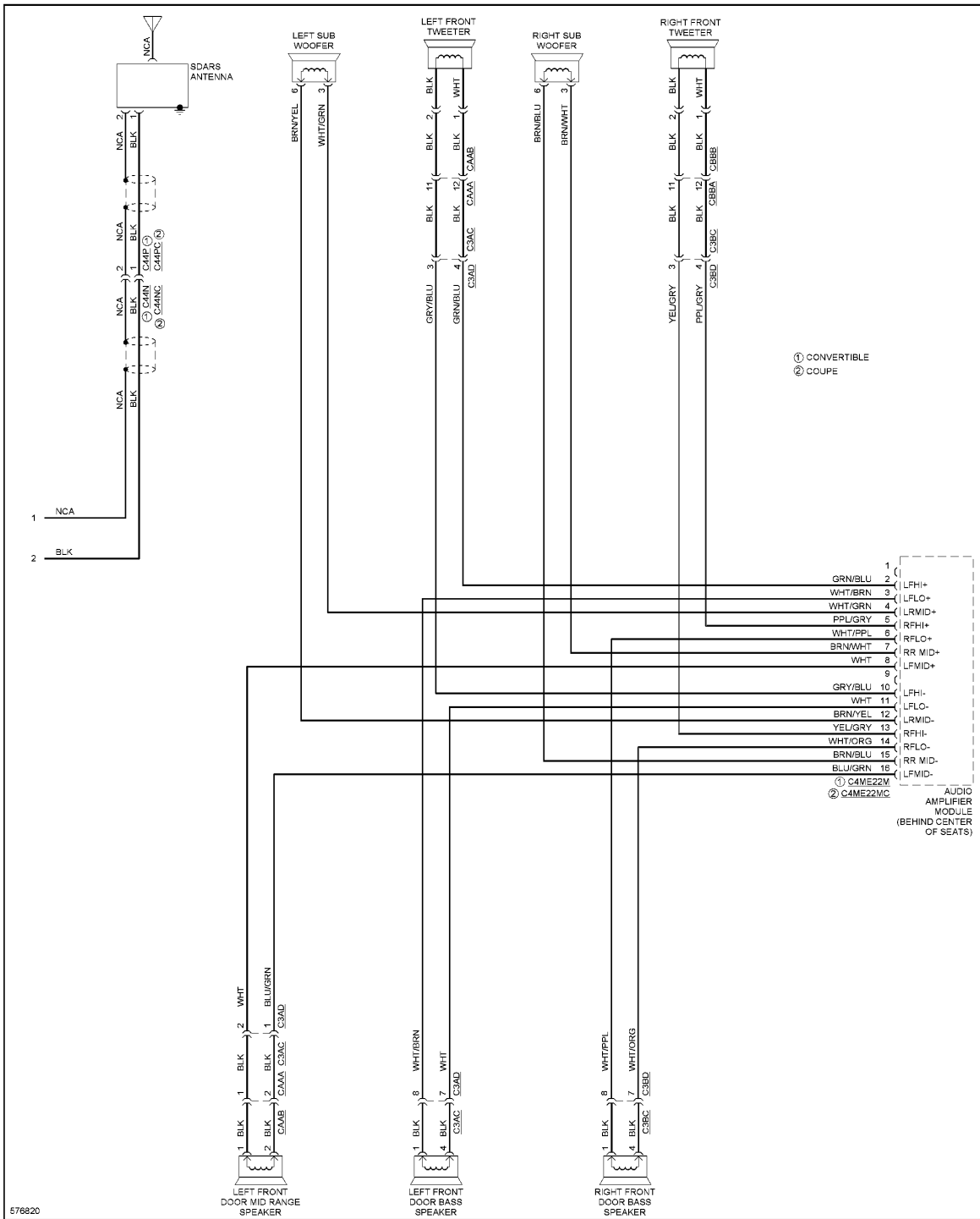
**Fig. 112: Premium Radio Circuit, W/ Control Touch W/O Hi-line Audio (2 of 5)**



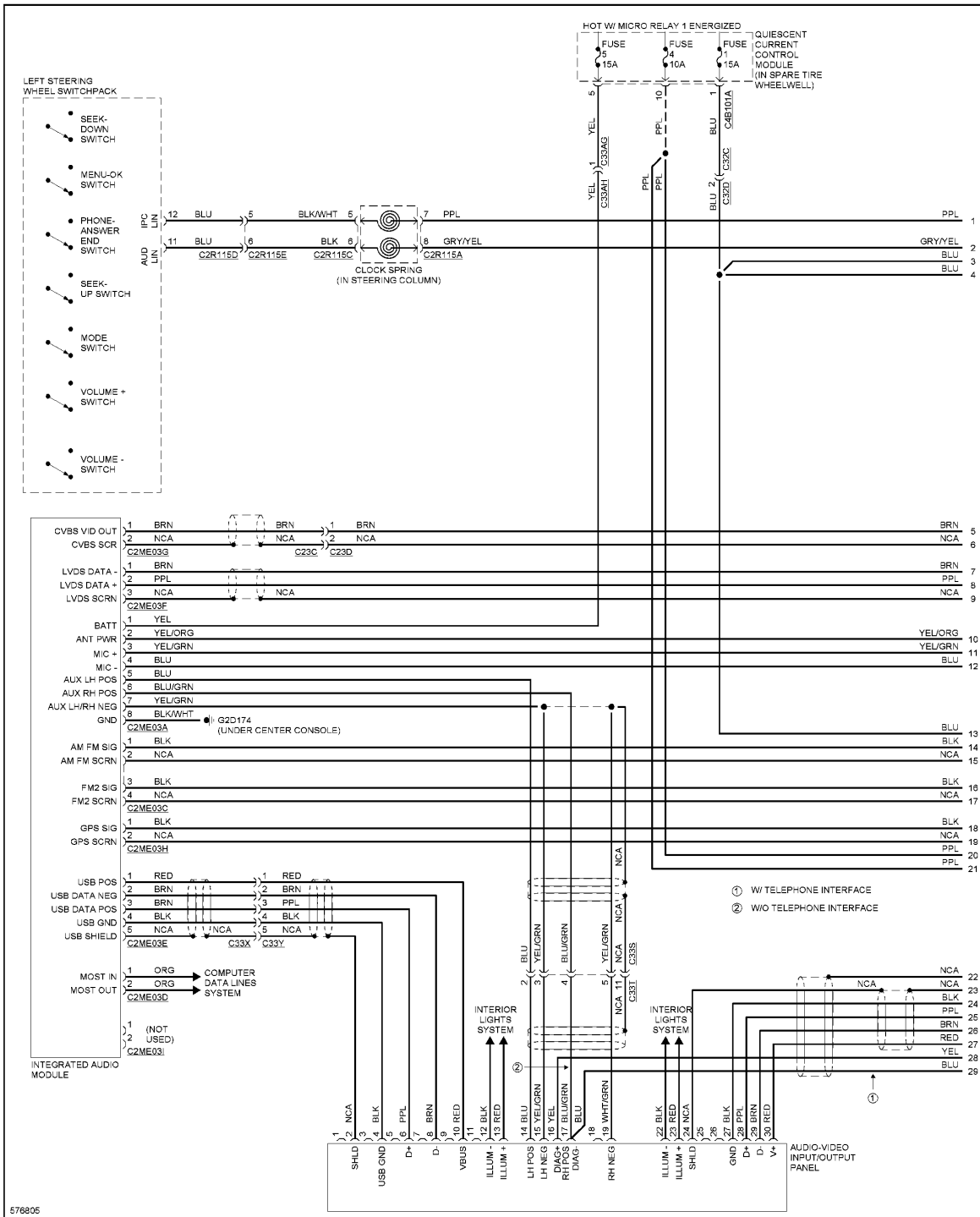
**Fig. 113: Premium Radio Circuit, W/ Control Touch W/O Hi-line Audio (3 of 5)**



**Fig. 114: Premium Radio Circuit, W/ Control Touch W/O Hi-line Audio (4 of 5)**

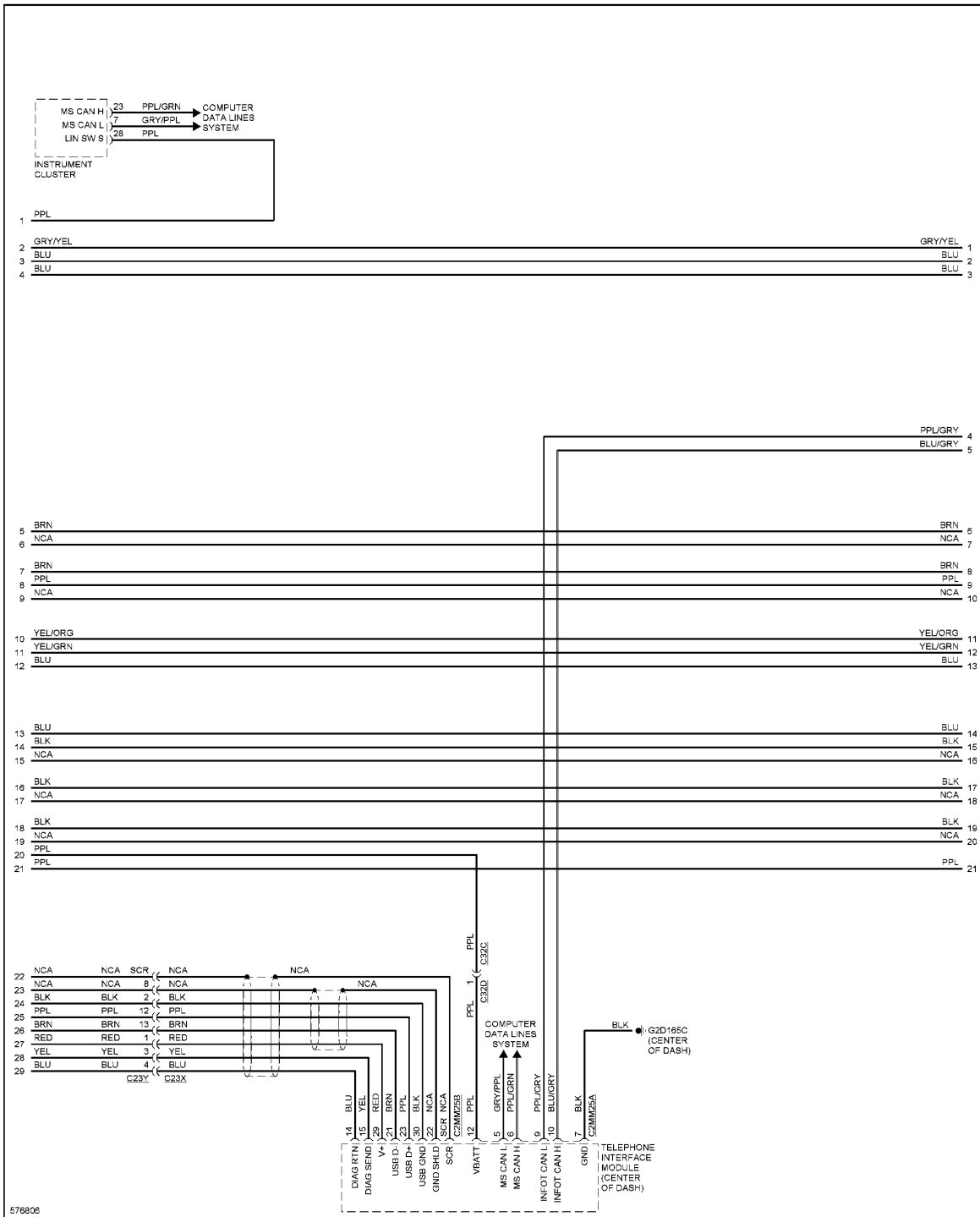


**Fig. 115: Premium Radio Circuit, W/ Control Touch W/O Hi-line Audio (5 of 5)**



**Fig. 116: Premium Radio Circuit, W/O Control Touch (1 of 6)**





**Fig. 117: Premium Radio Circuit, W/O Control Touch (2 of 6)**

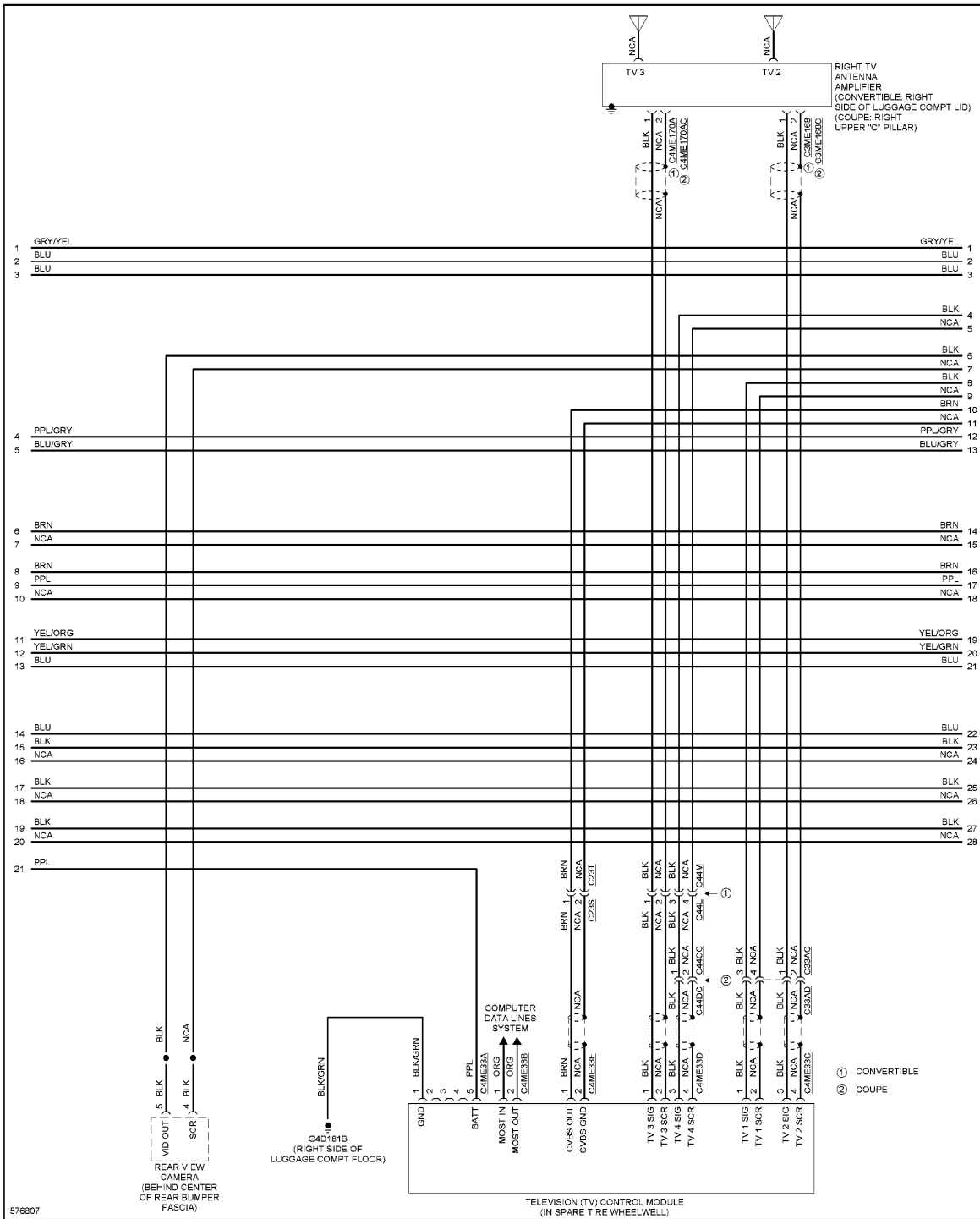
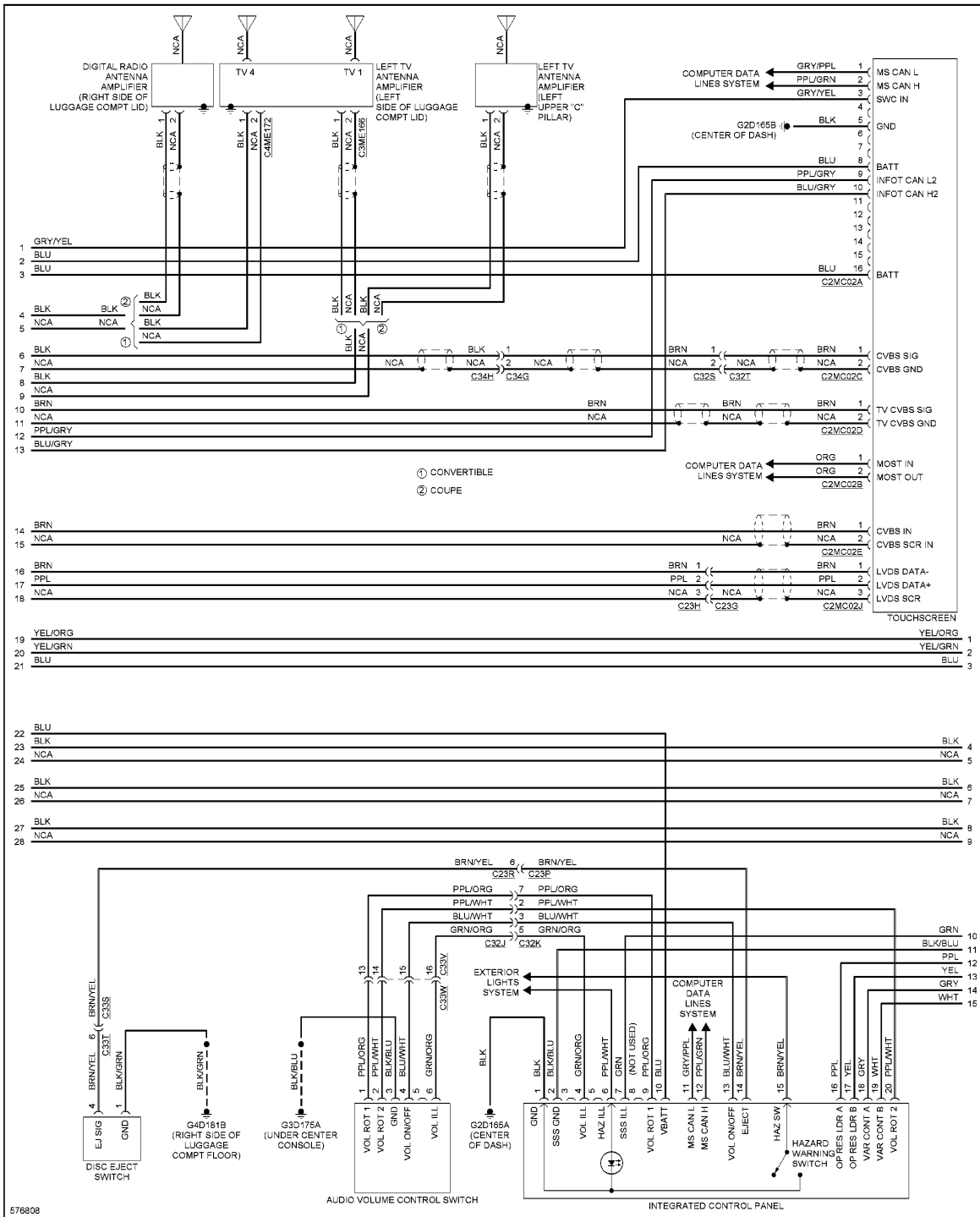
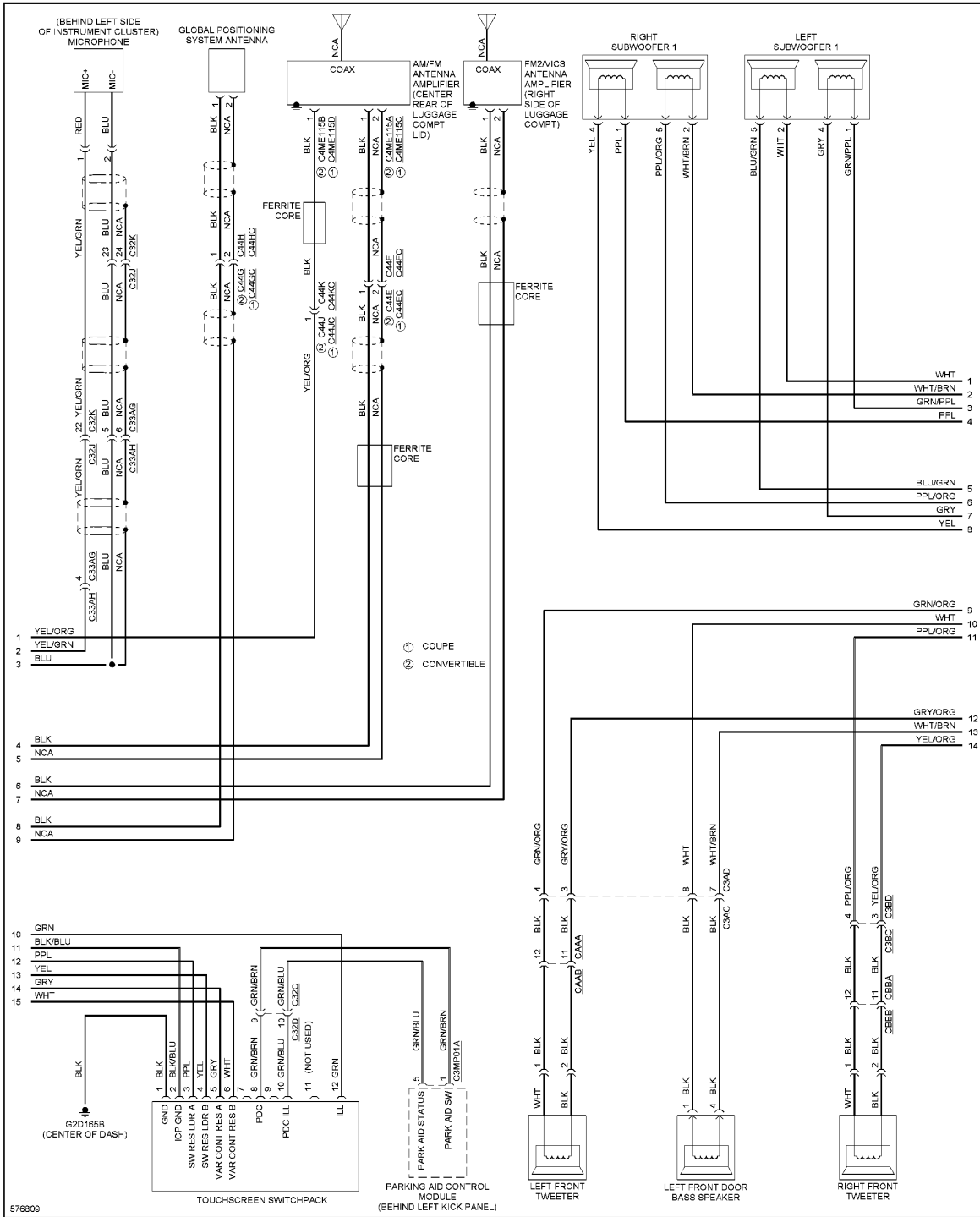


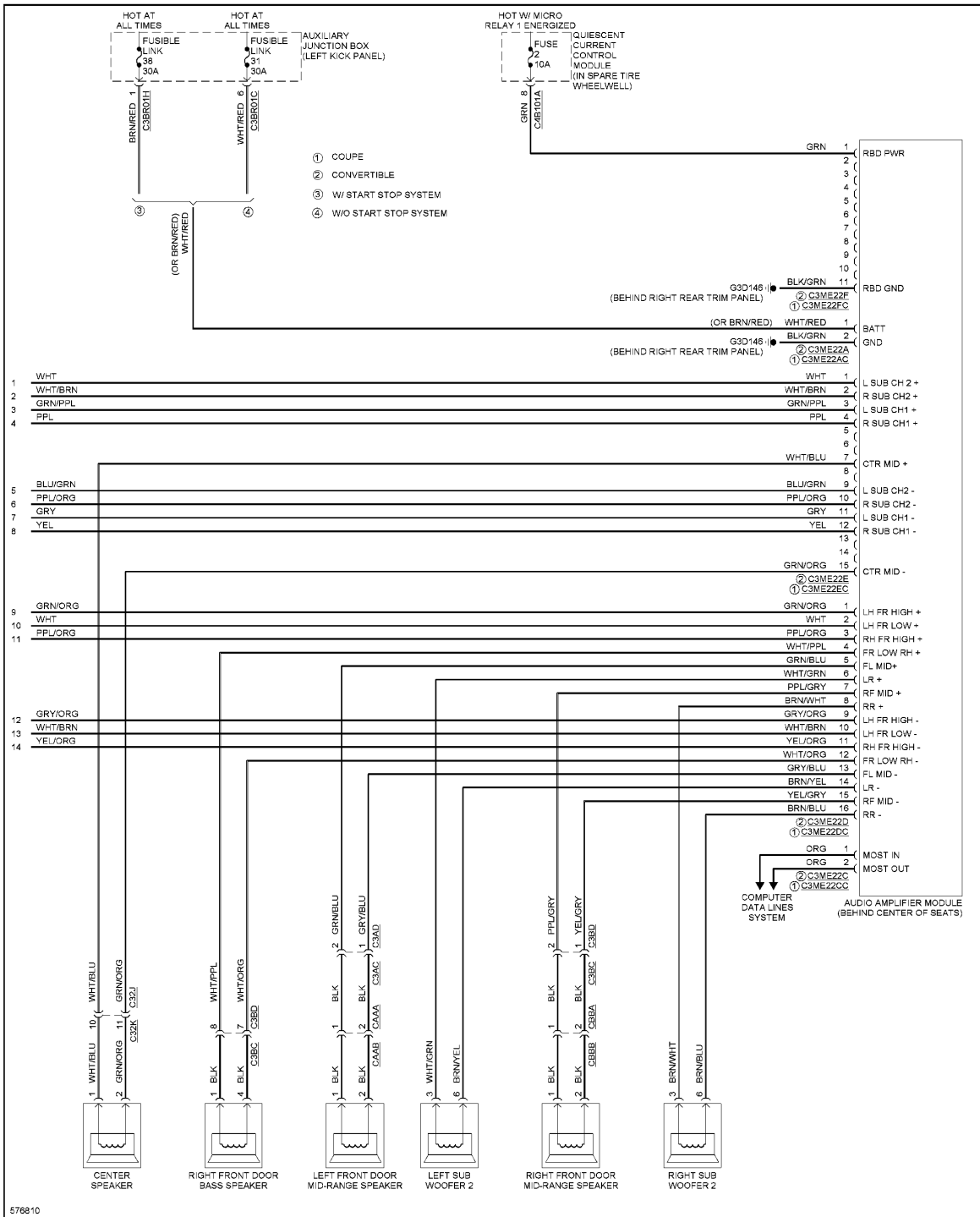
Fig. 118: Premium Radio Circuit, W/O Control Touch (3 of 6)



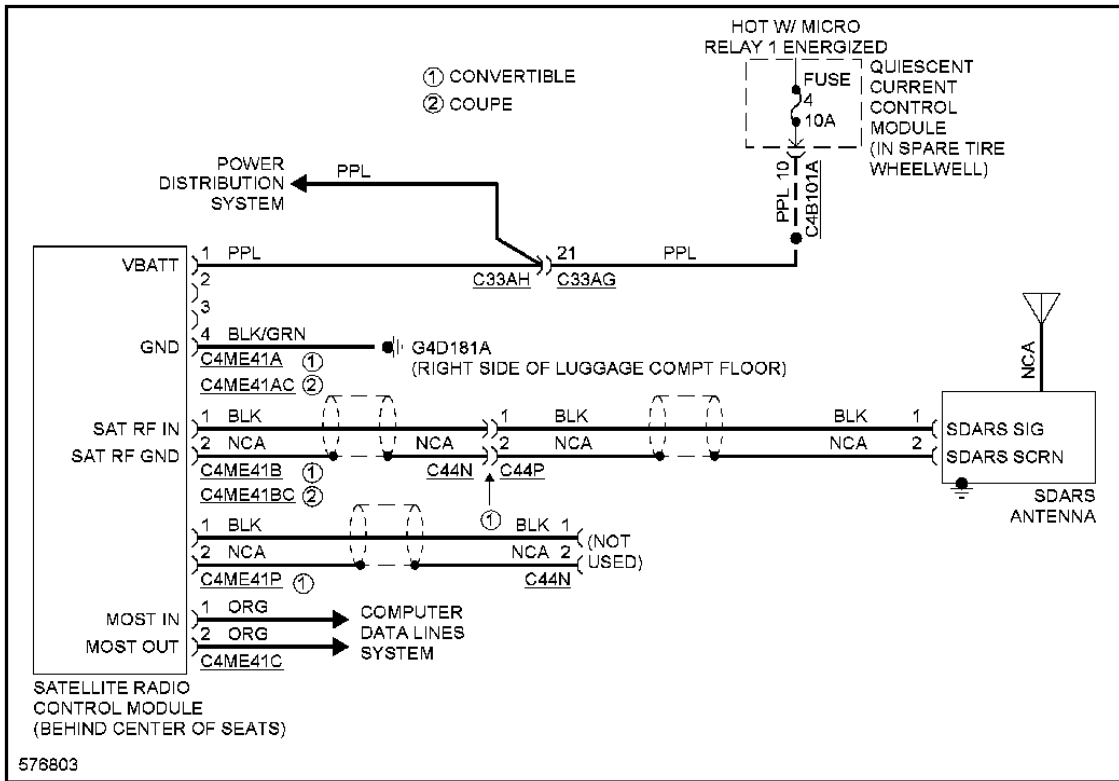
**Fig. 119: Premium Radio Circuit, W/O Control Touch (4 of 6)**



**Fig. 120: Premium Radio Circuit, W/O Control Touch (5 of 6)**

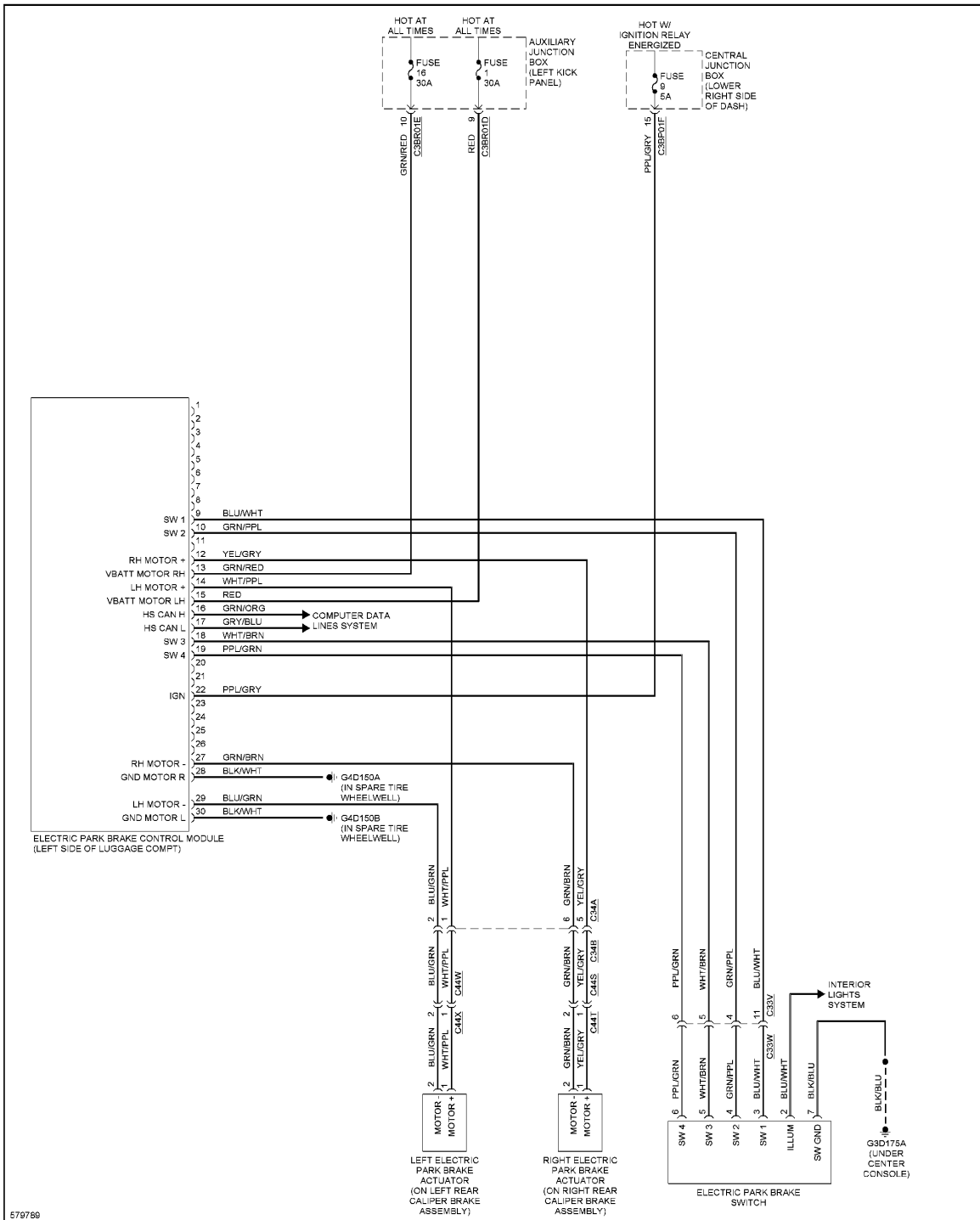


**Fig. 121: Premium Radio Circuit, W/O Control Touch (6 of 6)**



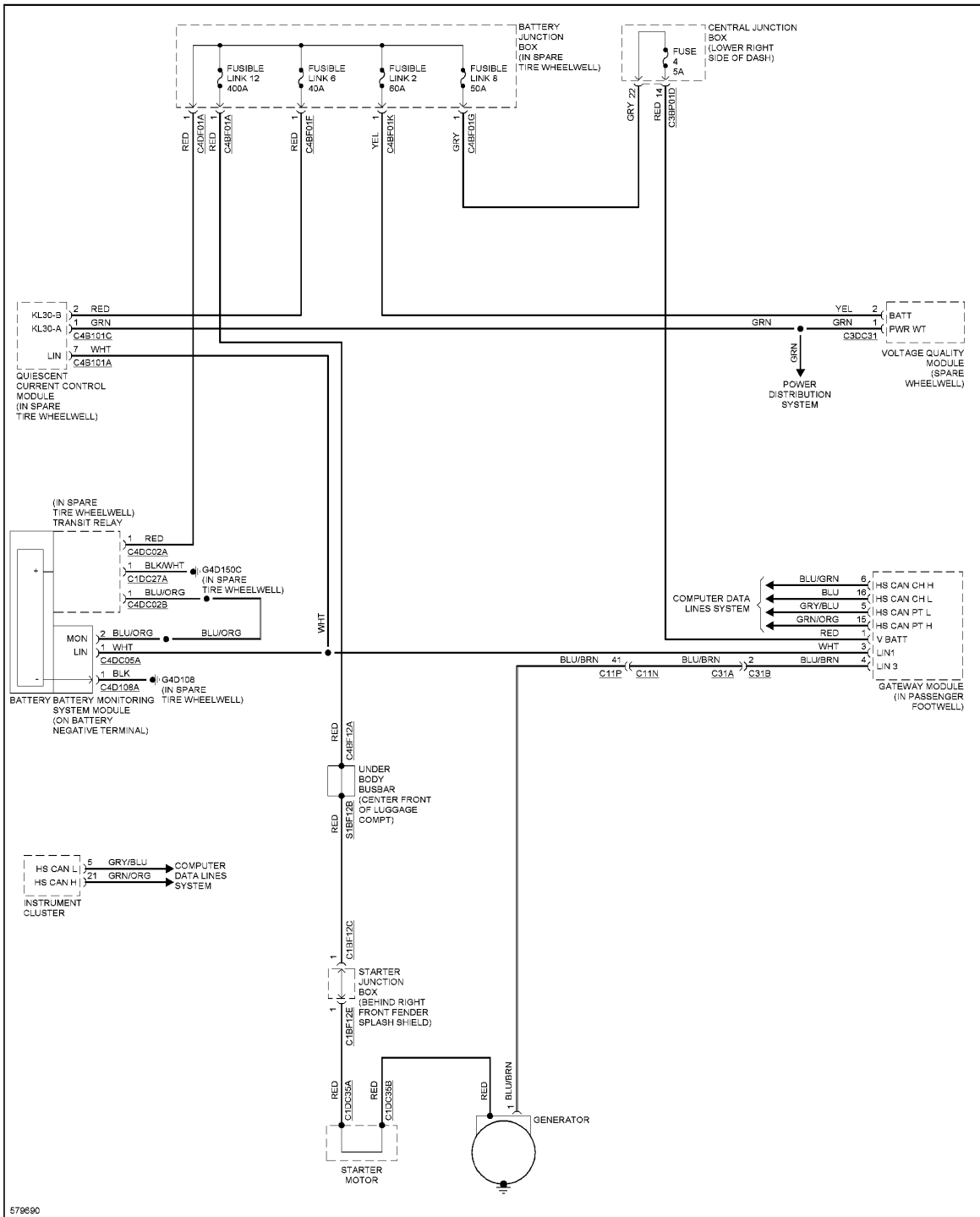
**Fig. 122: Satellite Radio Circuit**

**SHIFT INTERLOCK**



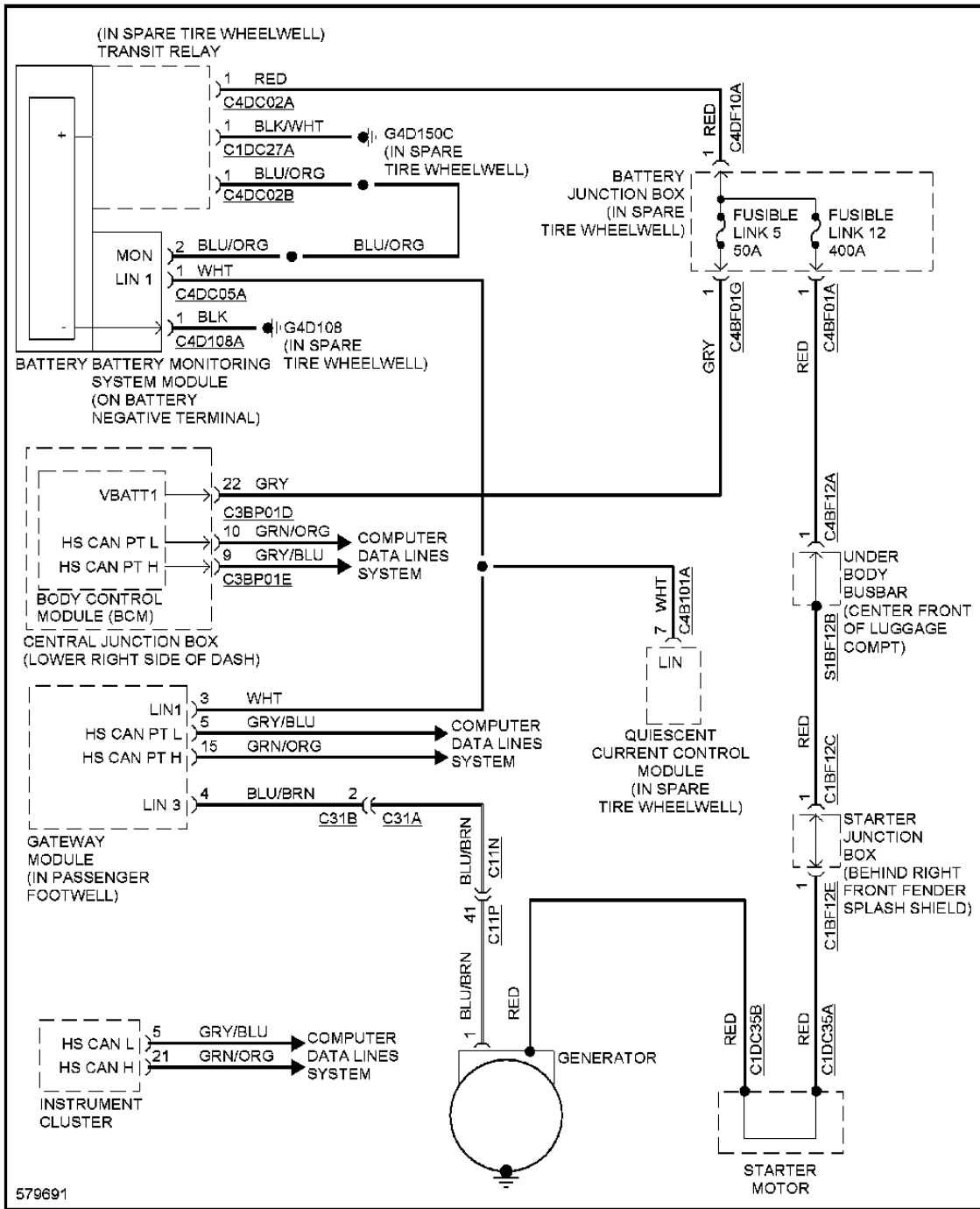
**Fig. 123: Shift Interlock Circuit**

**STARTING/CHARGING**

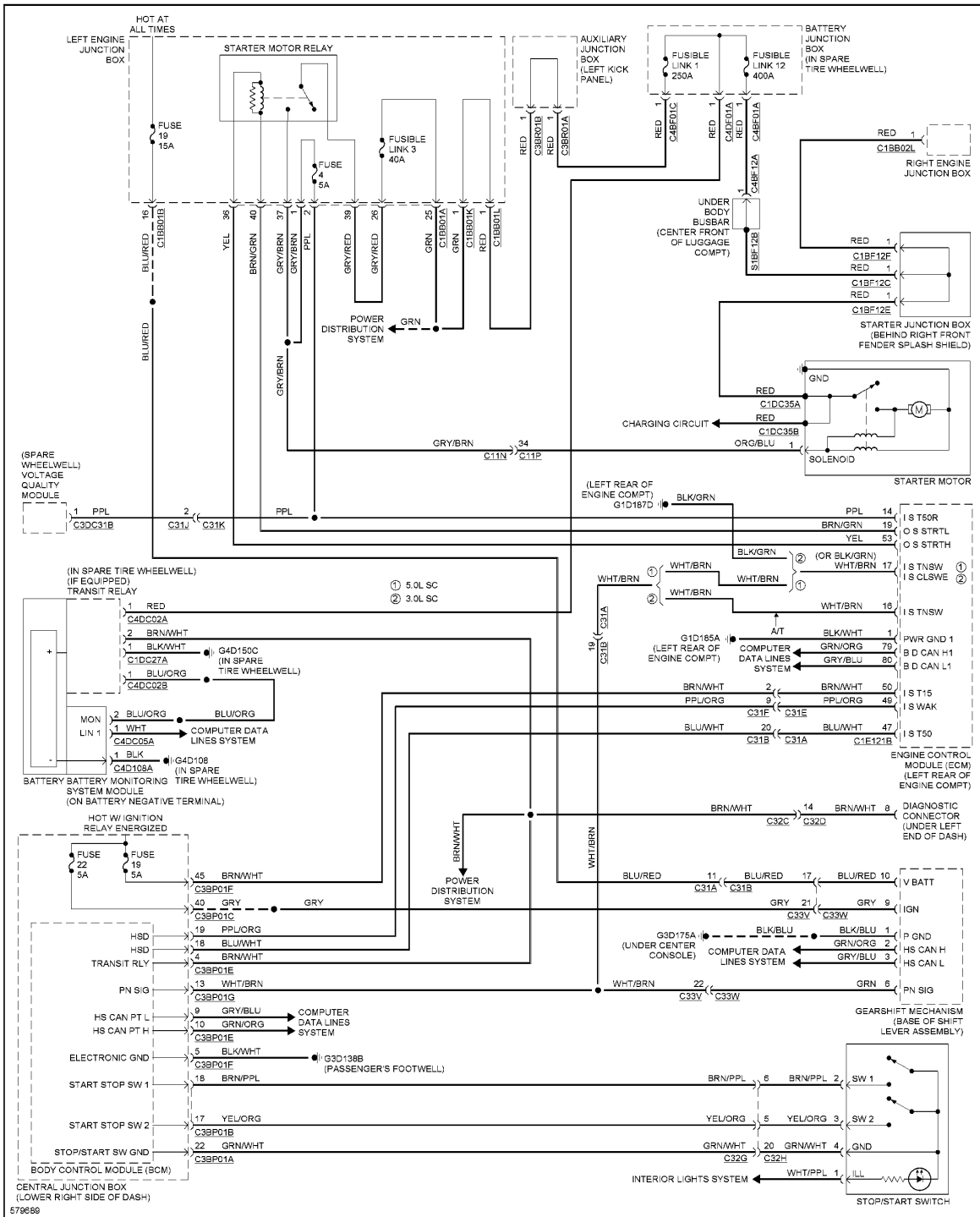


**Fig. 124: Charging Circuit, W/ Start-Stop System**



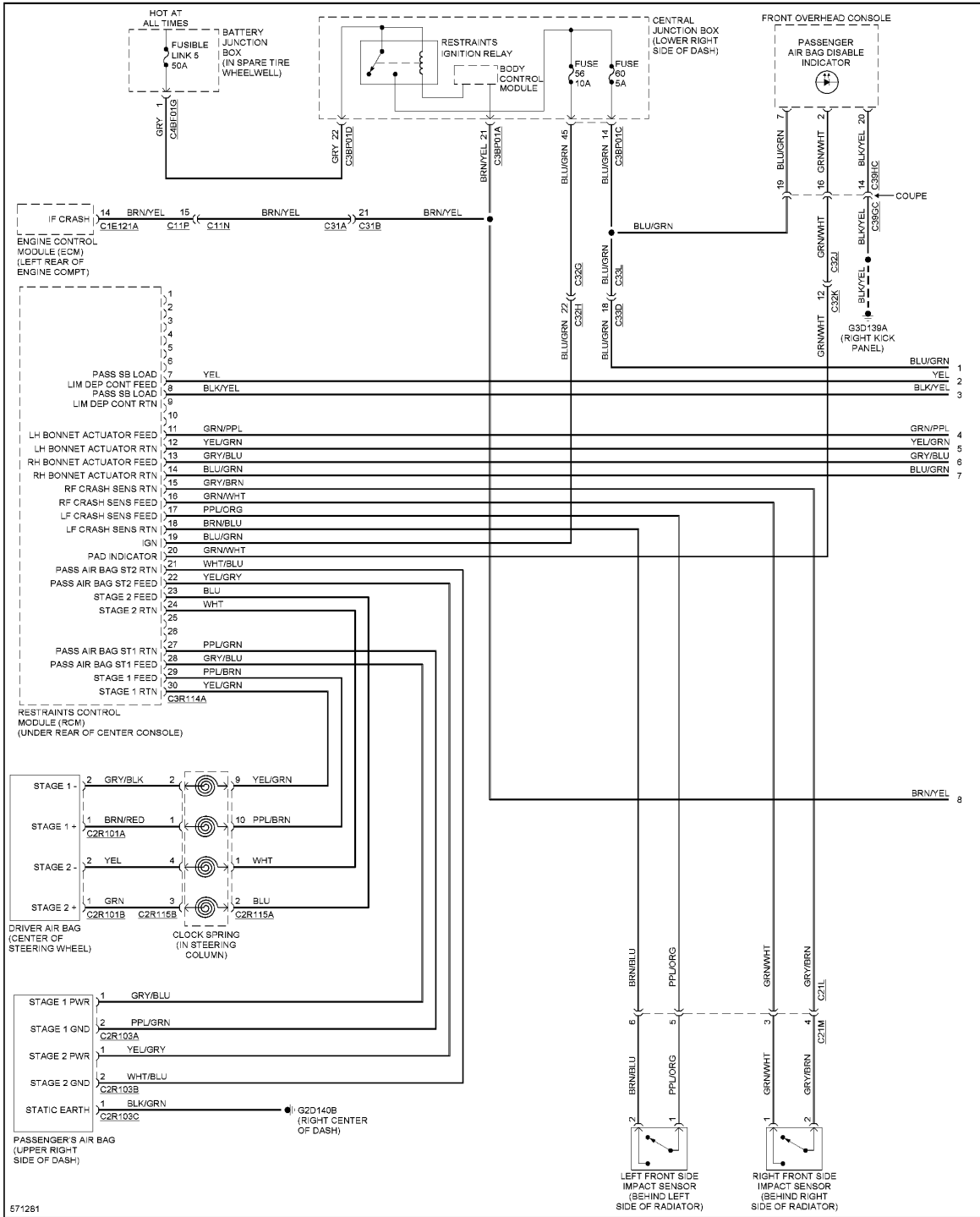


**Fig. 125: Charging Circuit, W/O Start-Stop System**

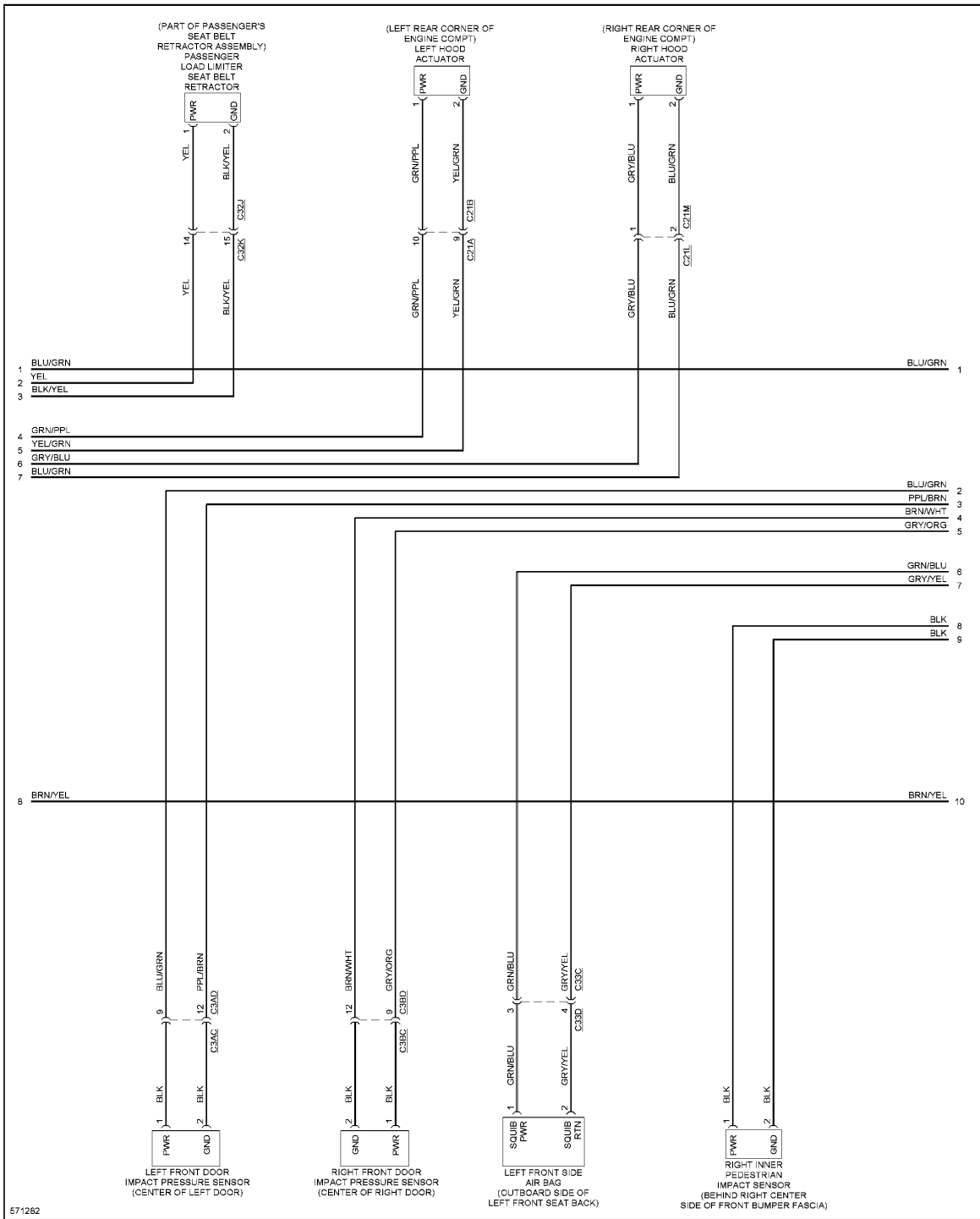


**Fig. 126: Starting Circuit**

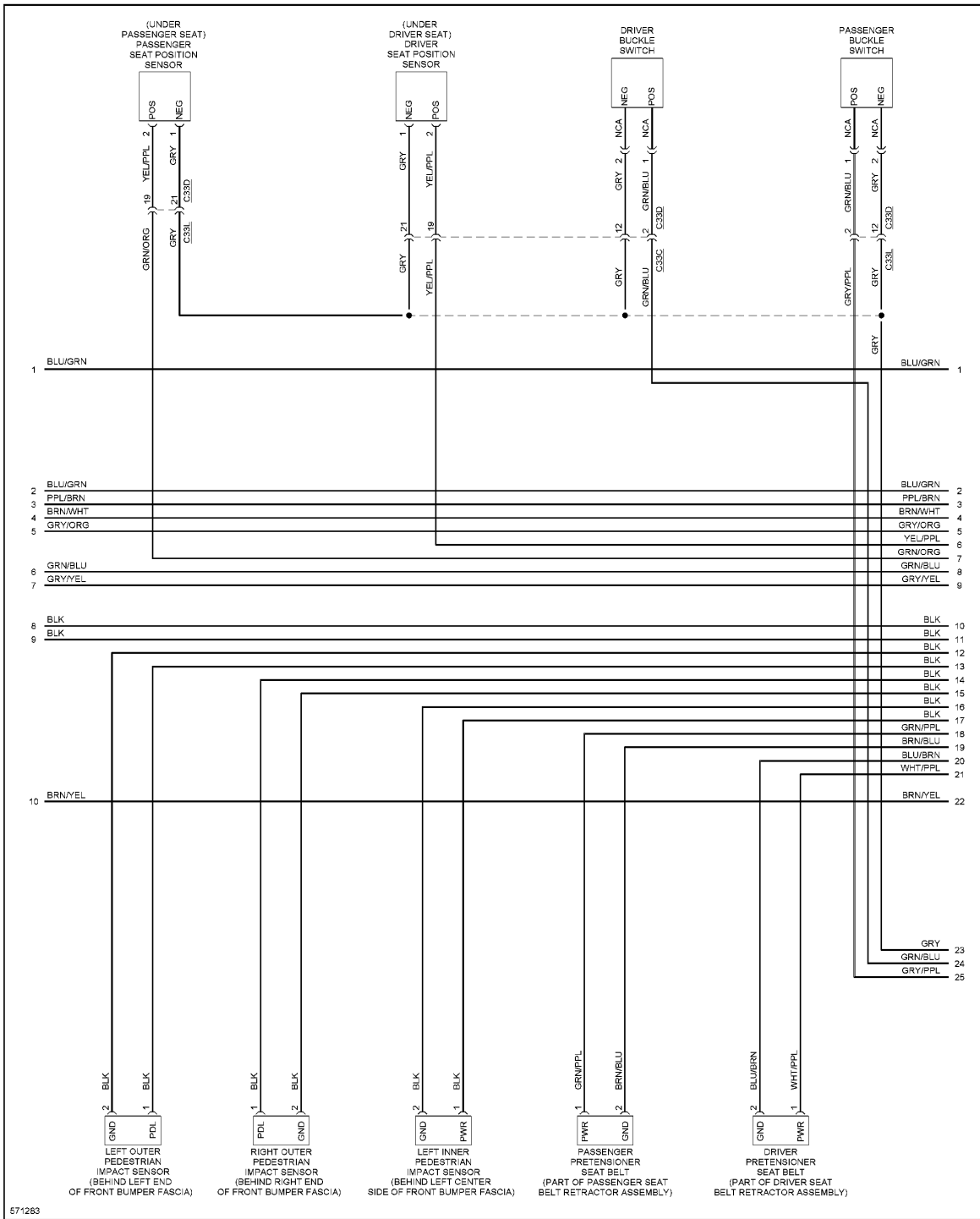
**SUPPLEMENTAL RESTRAINTS**



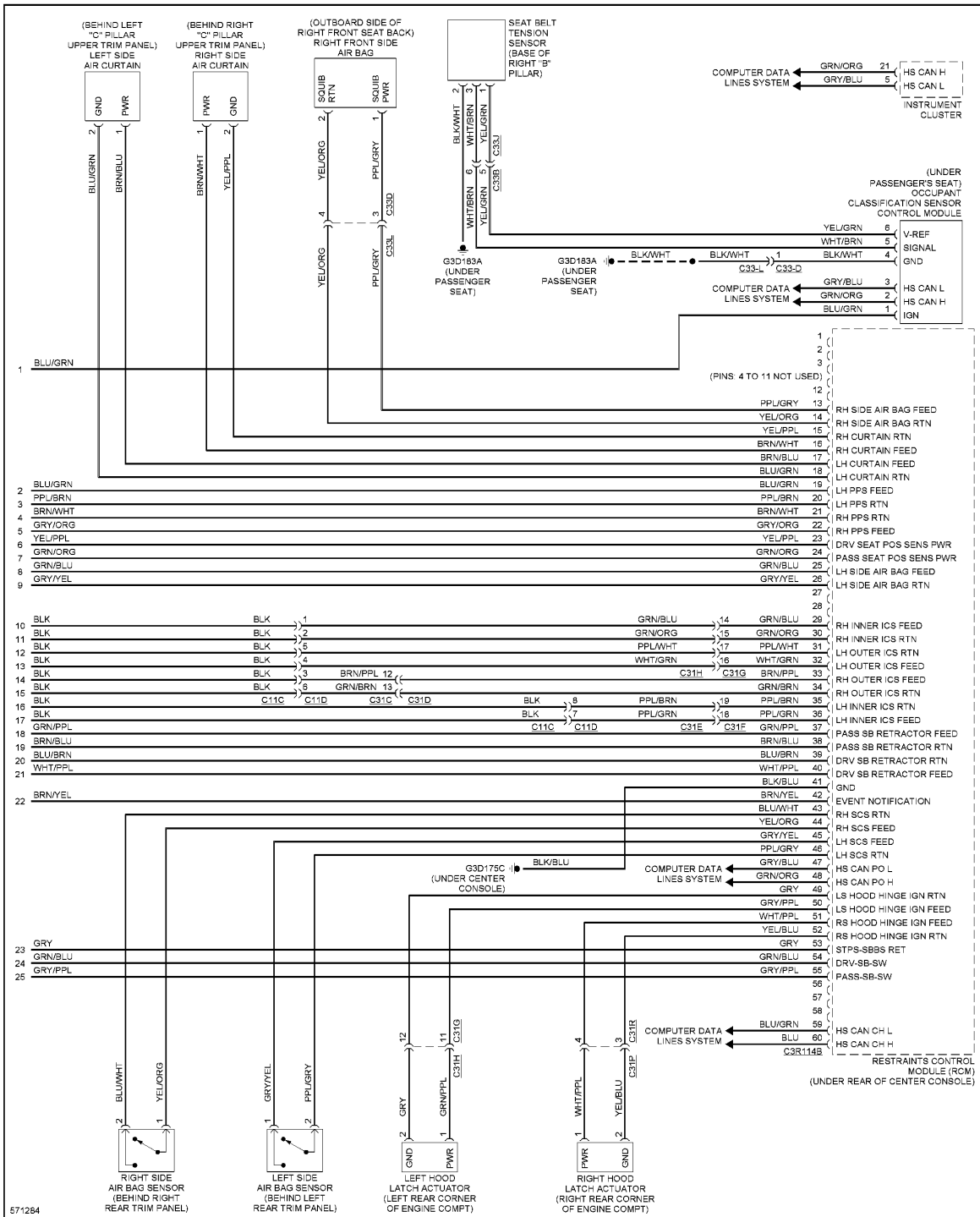
**Fig. 127: Supplemental Restraints Circuit (1 of 4)**



**Fig. 128: Supplemental Restraints Circuit (2 of 4)**

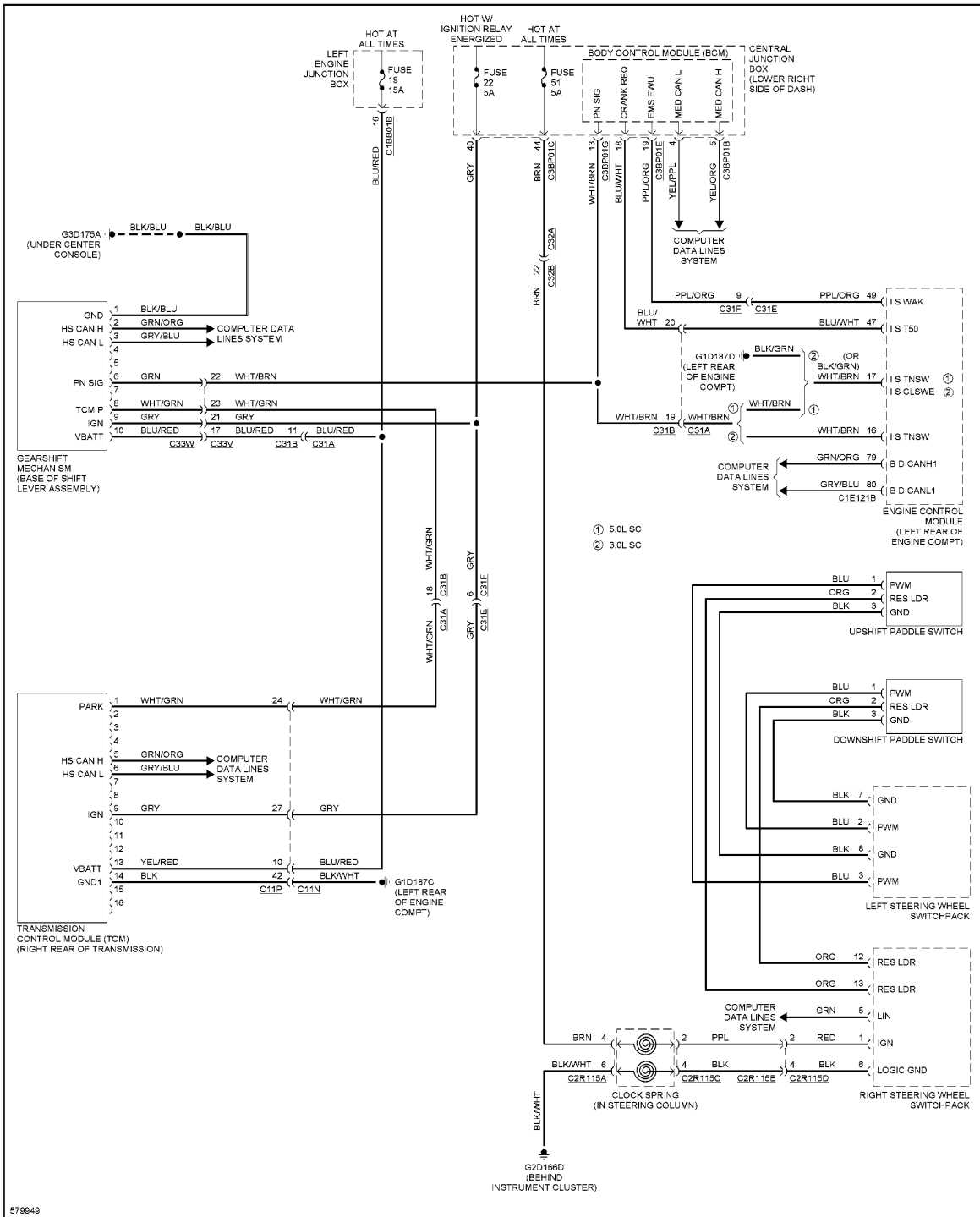


**Fig. 129: Supplemental Restraints Circuit (3 of 4)**

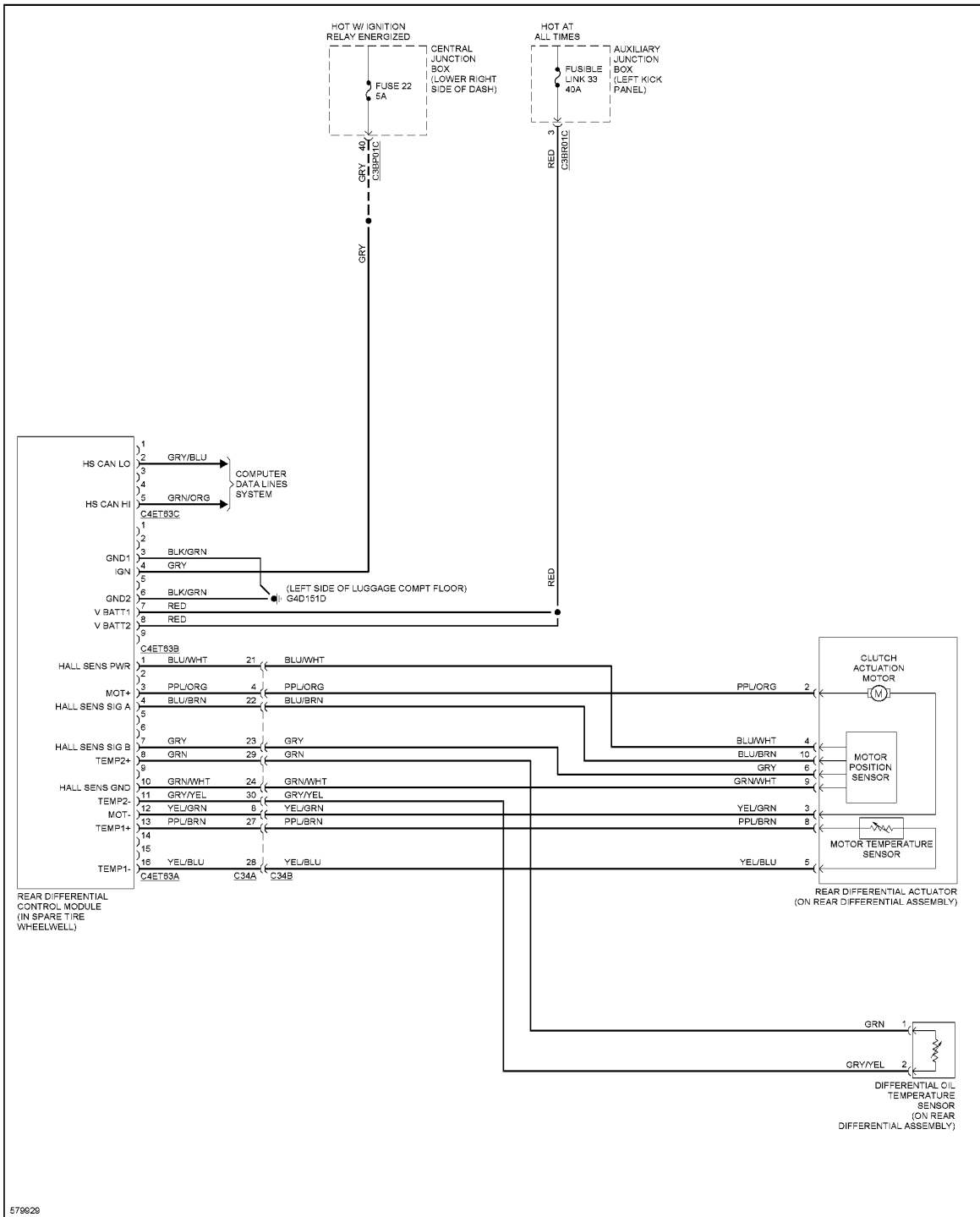


**Fig. 130: Supplemental Restraints Circuit (4 of 4)**

**TRANSMISSION**



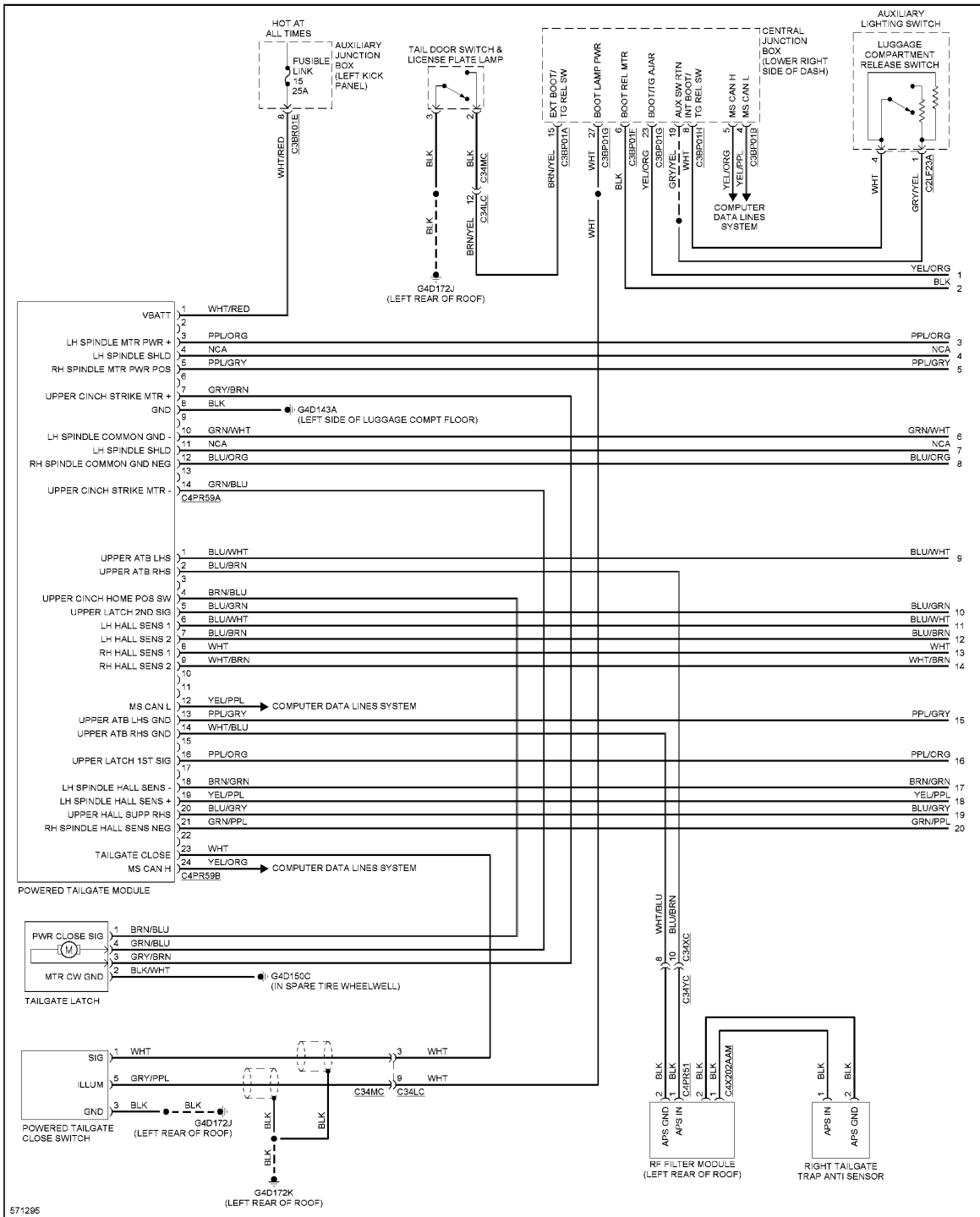
**Fig. 131: A/T Circuit**



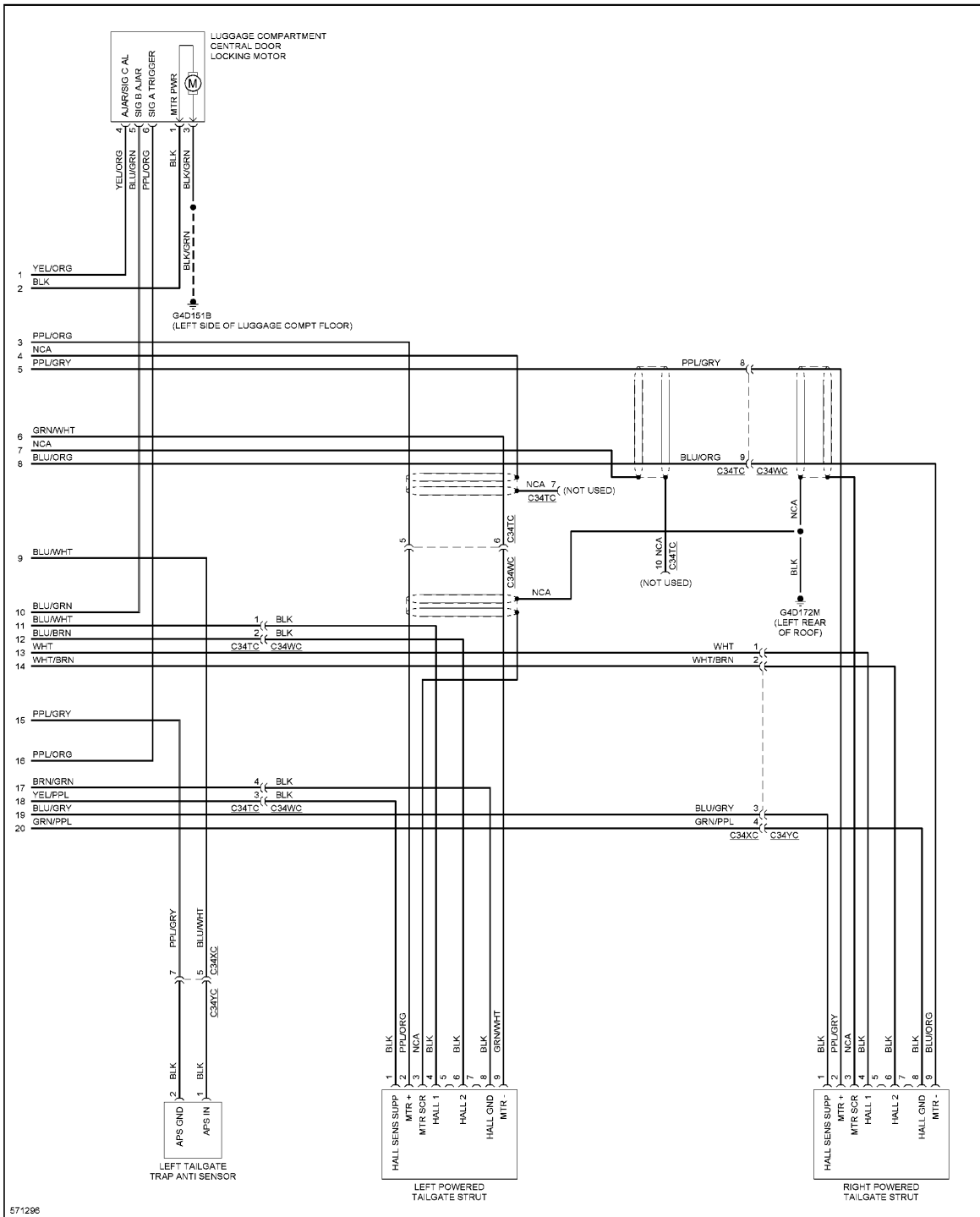
**Fig. 132: Rear Differential Lock Circuit**

**TRUNK, TAILGATE, FUEL DOOR**

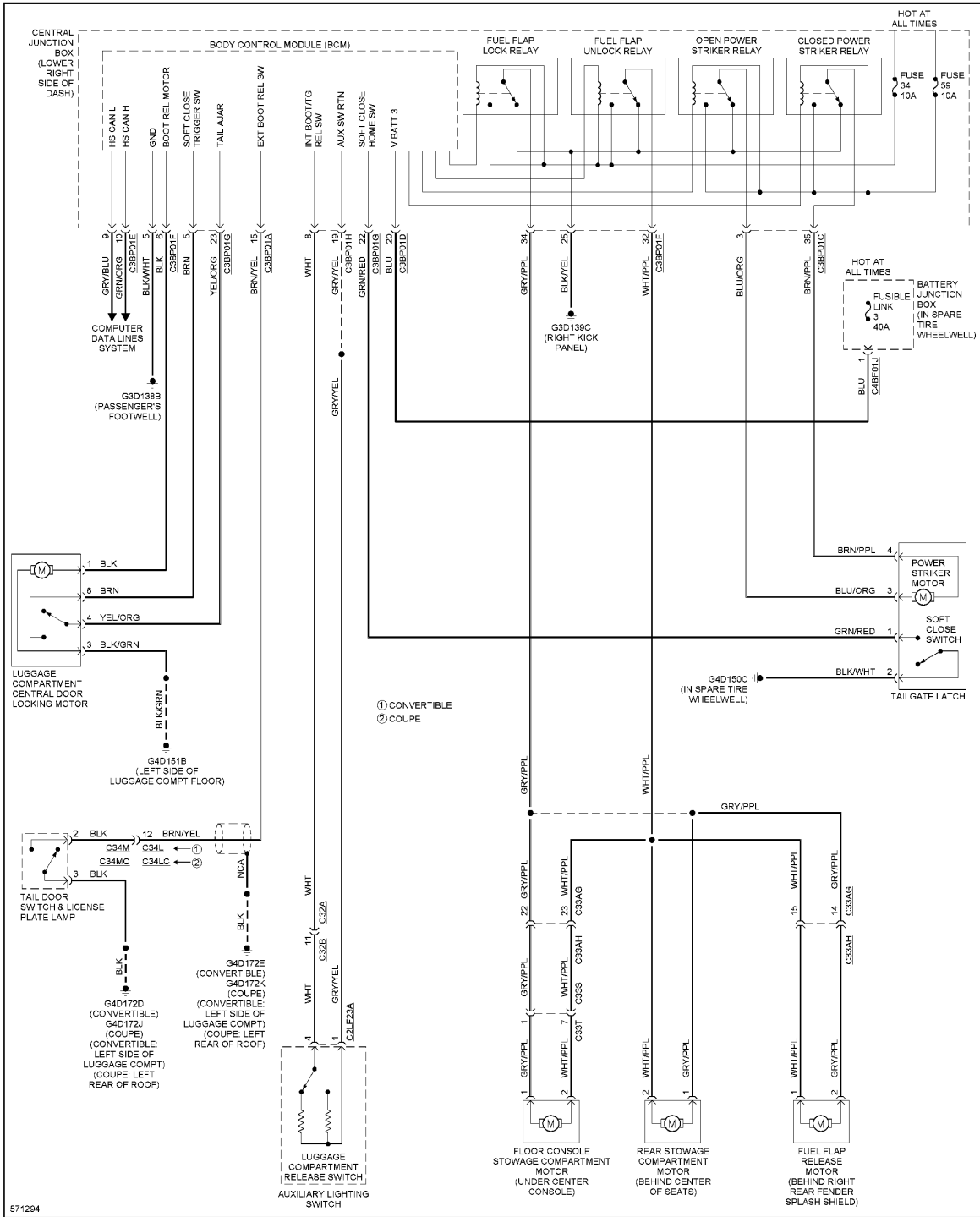




**Fig. 133: Power Tailgate Circuit (1 of 2)**

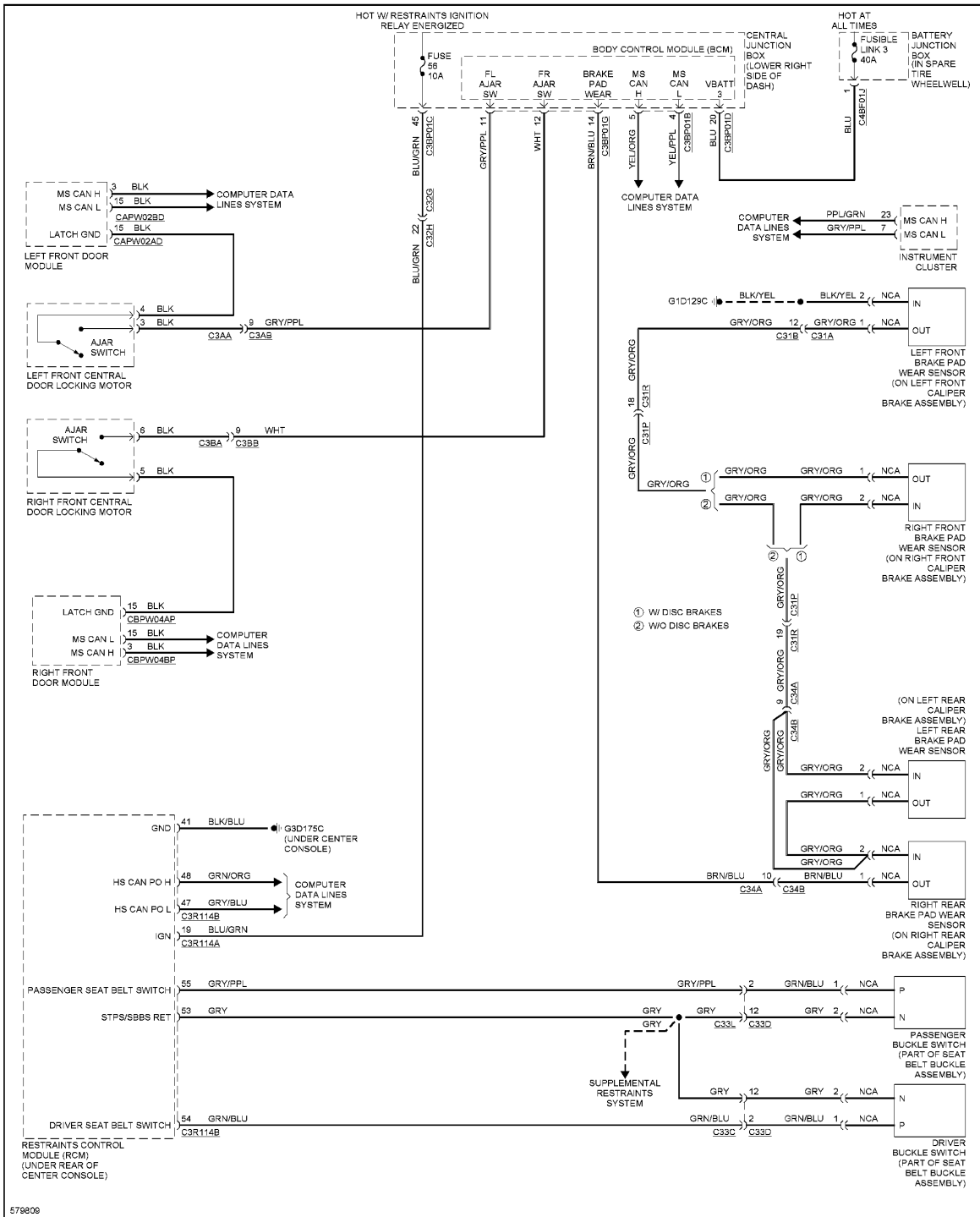


**Fig. 134: Power Tailgate Circuit (2 of 2)**



**Fig. 135: Tailgate & Fuel Door Release Circuit**

**WARNING SYSTEMS**



**Fig. 136: Seat Belt Warning Circuit**

**Fig. 137: Tire Pressure Monitoring Circuit**

## WIPER/WASHER

**Fig. 138: Wiper/Washer Circuit (1 of 2)**

**Fig. 139: Wiper/Washer Circuit (2 of 2)**