

INTERIOR TRIM AND ORNAMENTATION

HEADLINER - COUPE (G1822890)

REMOVAL AND INSTALLATION

REMOVAL

NOTE:

Removal steps in this procedure may contain installation details.

1.

NOTE:

Adjust the steering wheel to the lowest position.

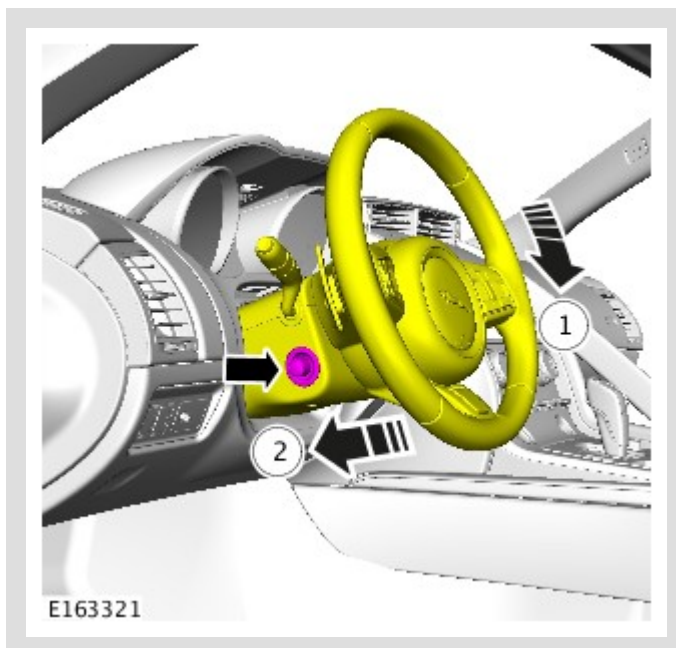

2. Refer to: Battery Disconnect and Connect (414-01, General Procedures).

3. Refer to: Supplementary Restraint System Health and Safety Precautions (100-00, Description and Operation).

4.  **NOTE:**

Repeat the procedure for the other side.

Refer to: A-Pillar Trim Panel - Coupe (501-05, Removal and Installation).

5.  **NOTE:**

Repeat the procedure for the other side.

Refer to: Sun Visor (501-05, Removal and Installation).

6. Refer to: Overhead Console (501-12, Removal and Installation).

7. Refer to: Auto-Dimming Interior Mirror - Coupe (501-09, Removal and Installation).

8.  **NOTE:**

Repeat the procedure for the other side.

Refer to: C-Pillar Trim Panel - Coupe (501-05, Removal and Installation).

- 9.

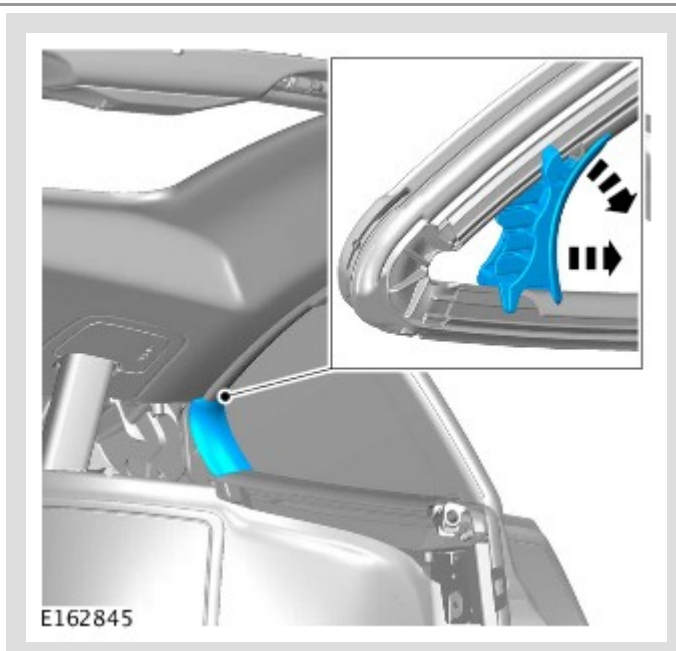

10.

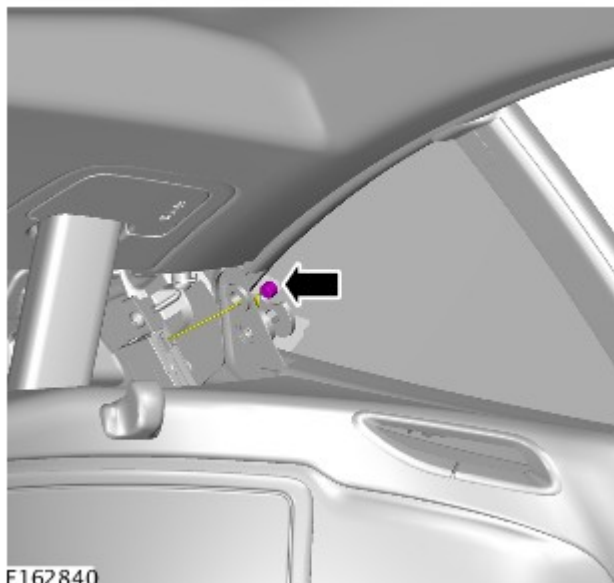

E162840

11.

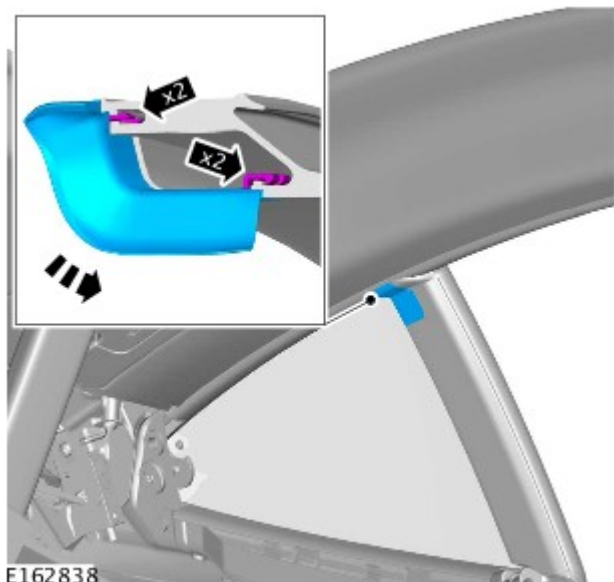

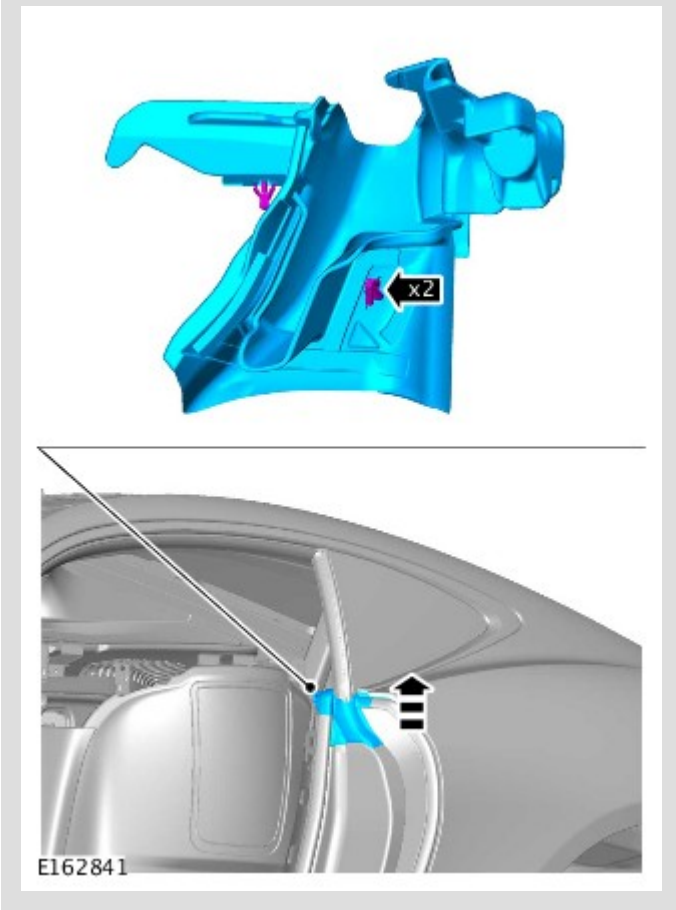

E162838

12.

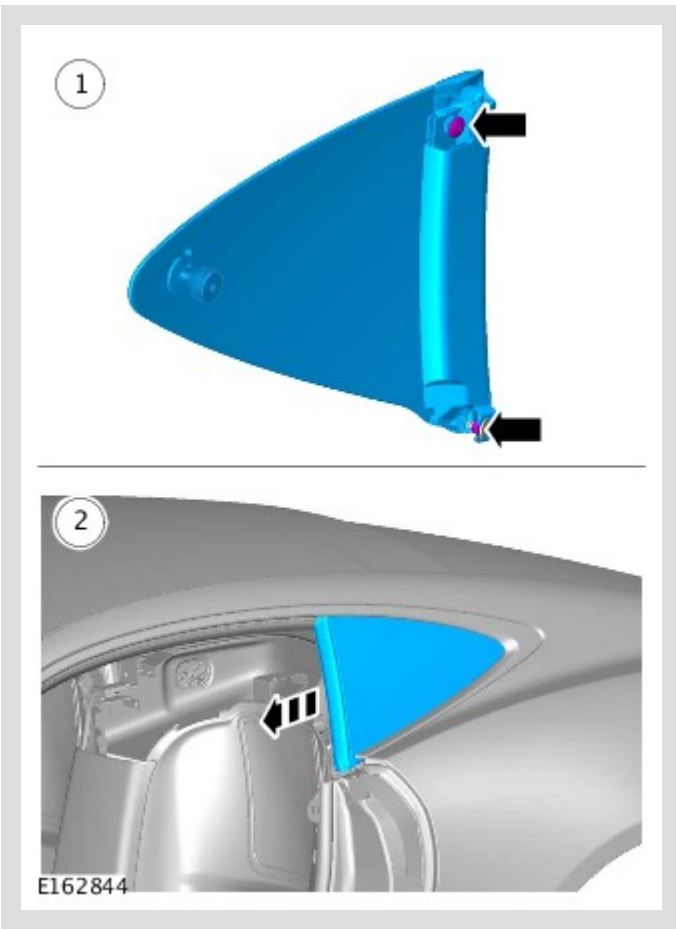

13.



 NOTE:

Repeat the step for the other side.

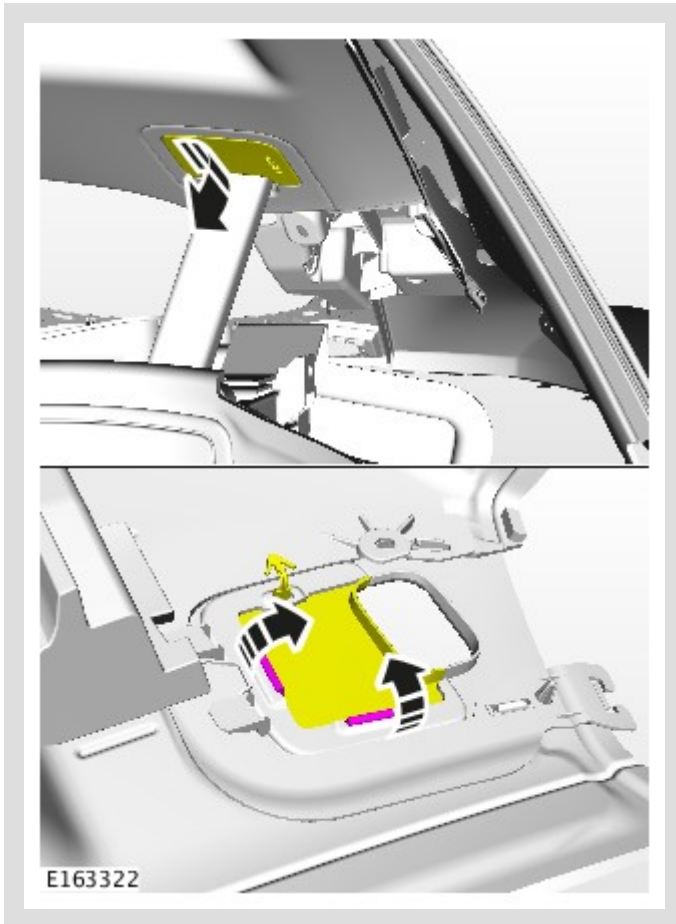

15.

NOTE:

Repeat the step for the other side.

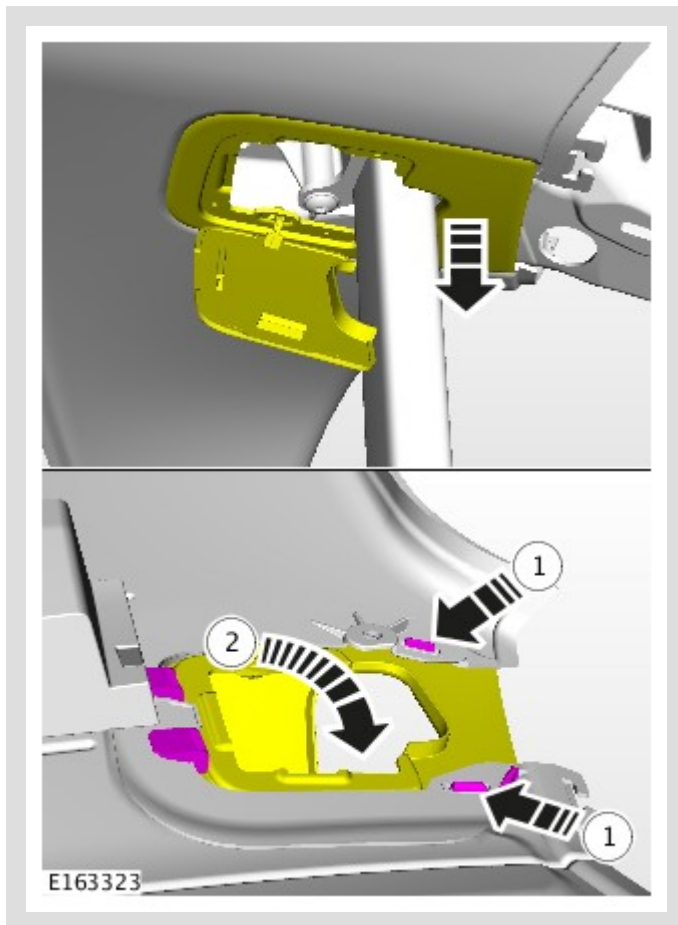

16.

NOTE:

Repeat the step for the other side.



17.

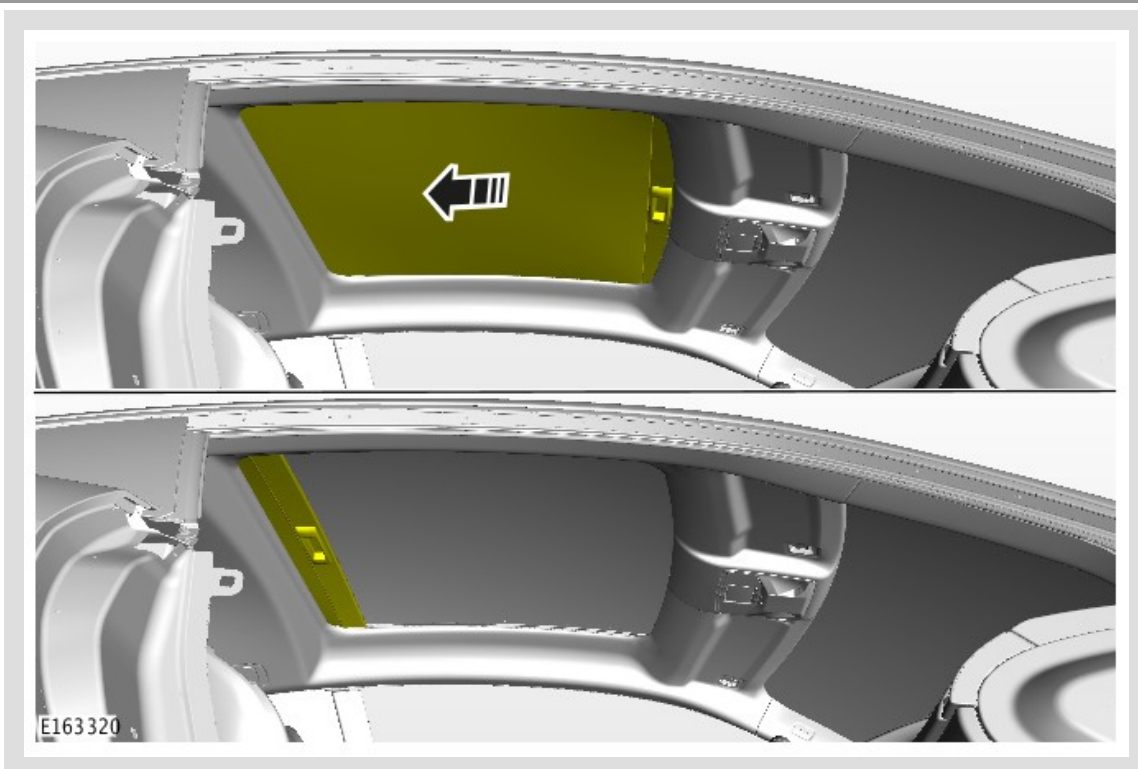

18.

⚠ CAUTION:

Take extra care not to damage the component.

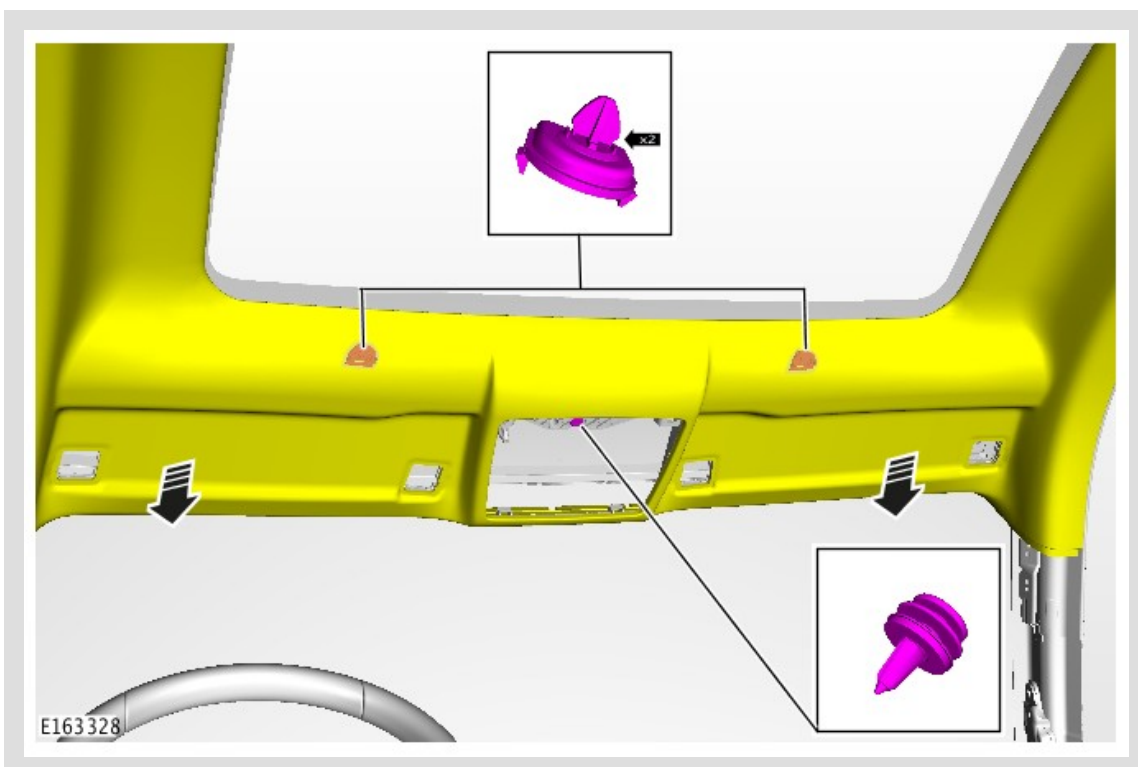

⚠ CAUTION:

Take extra care not to damage the component.

🔄 NOTE:

Repeat the step for the other side.

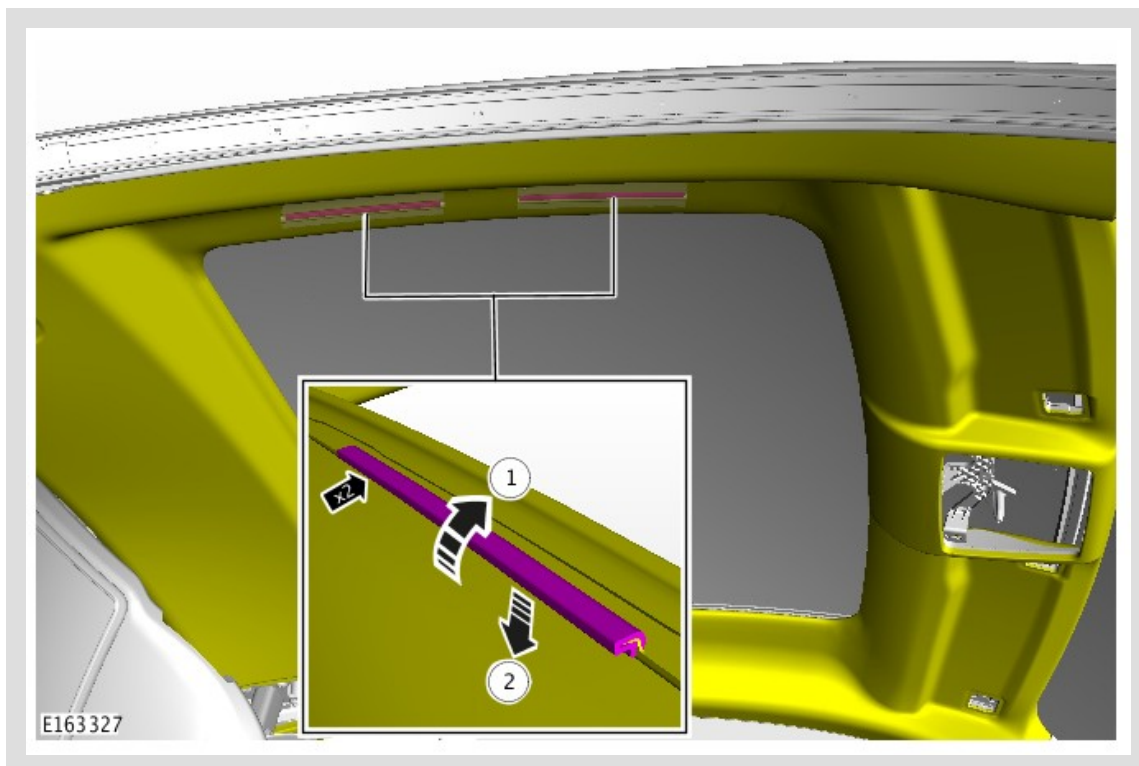

⚠ CAUTION:

Take extra care not to damage the component.

△ NOTE:

Make sure that there is at least 50mm clearance between the magnetic fixings and the headliner during the removal procedure. The fixings will engage if too close to each other.

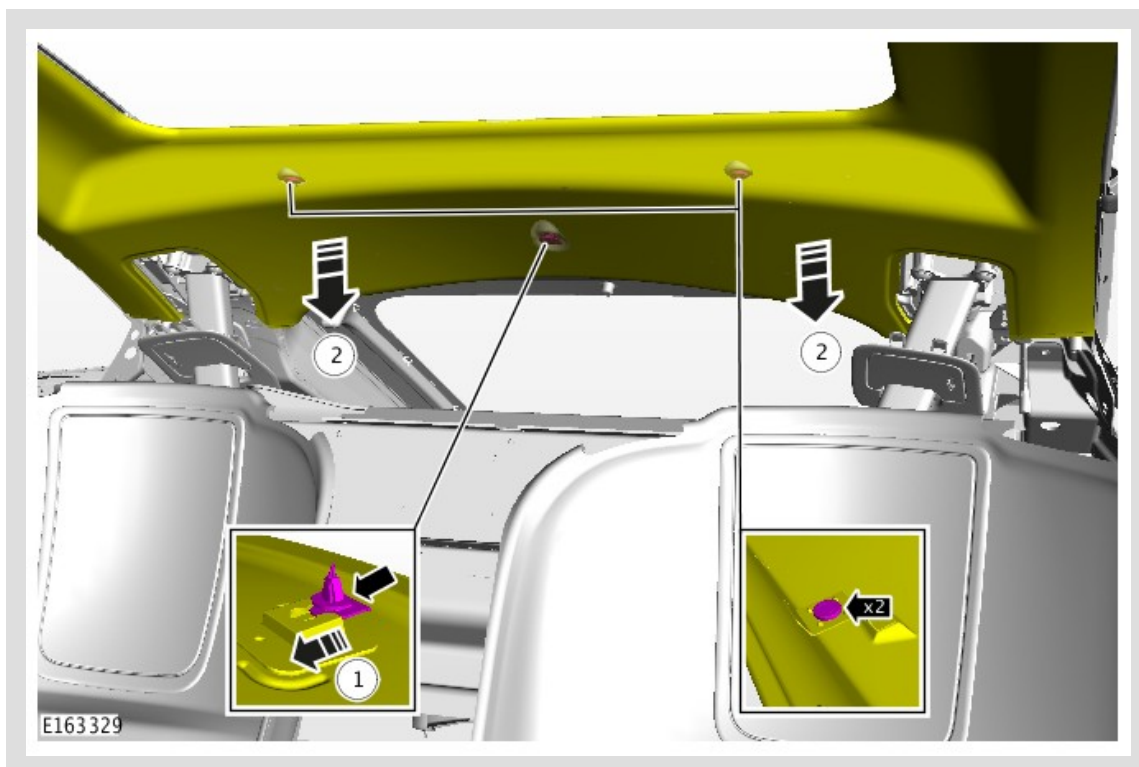

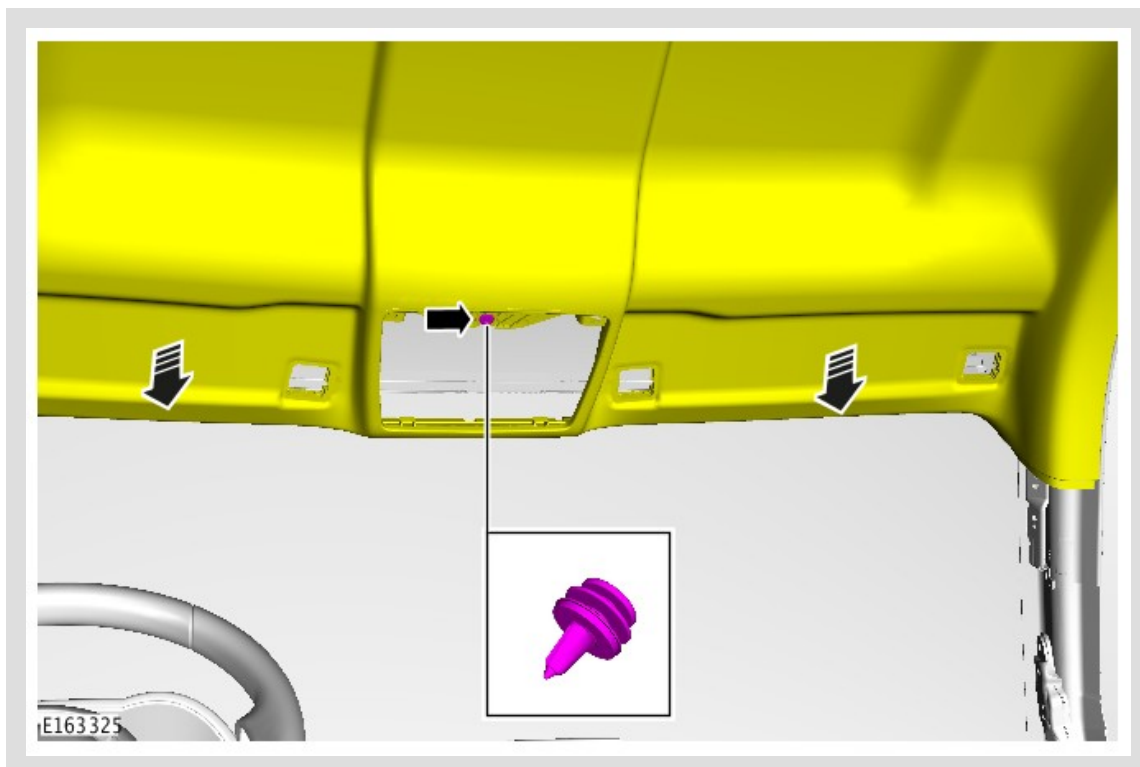

! CAUTION:

Take extra care not to damage the component.

**!** CAUTION:

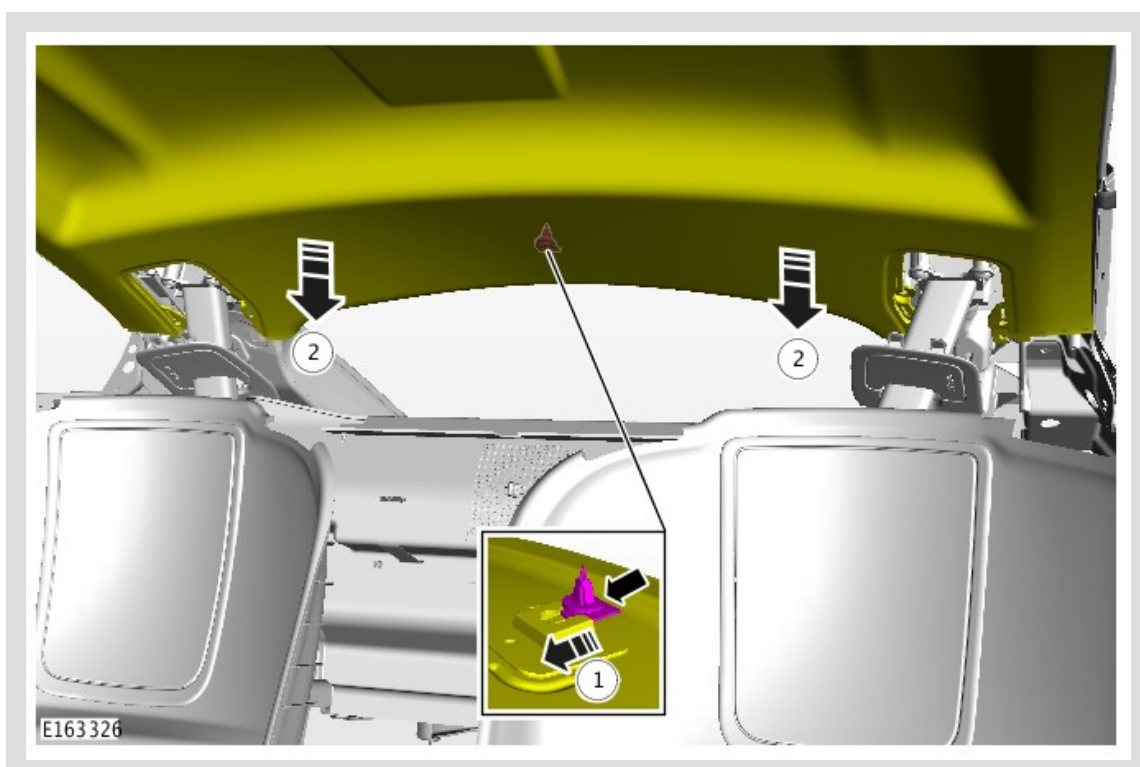
Take extra care not to damage the component.



 NOTE:

Lower and position the headliner forward to aid access.

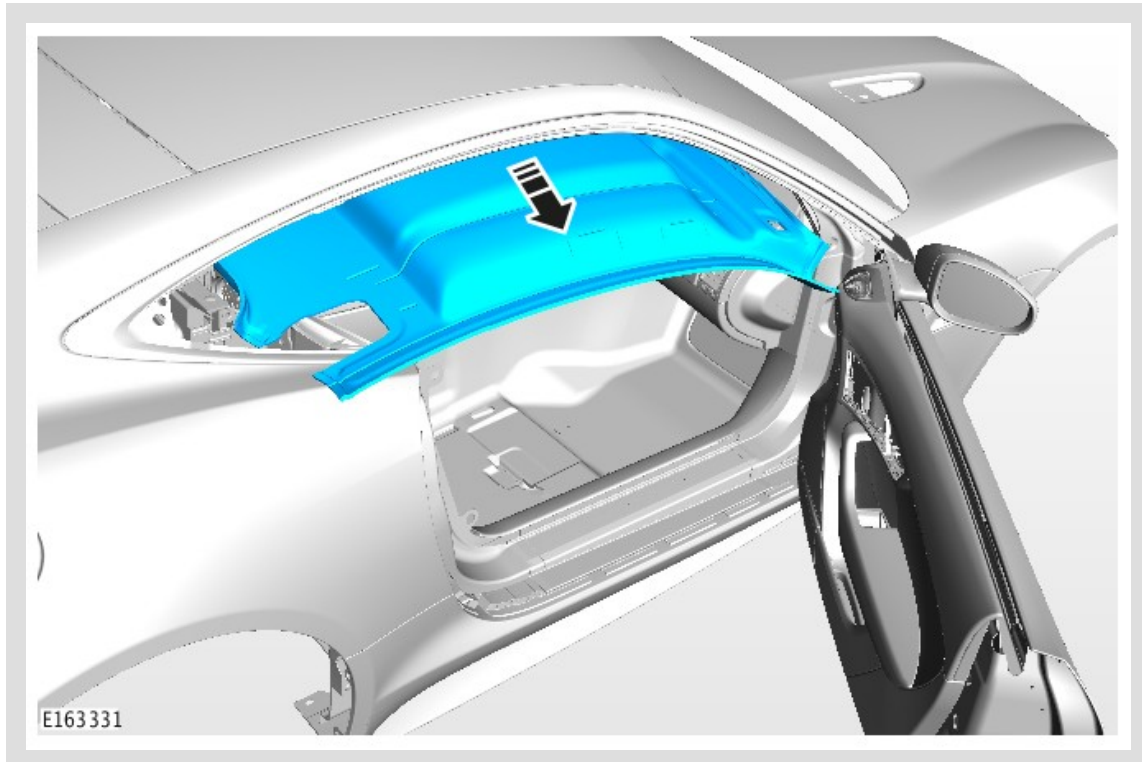
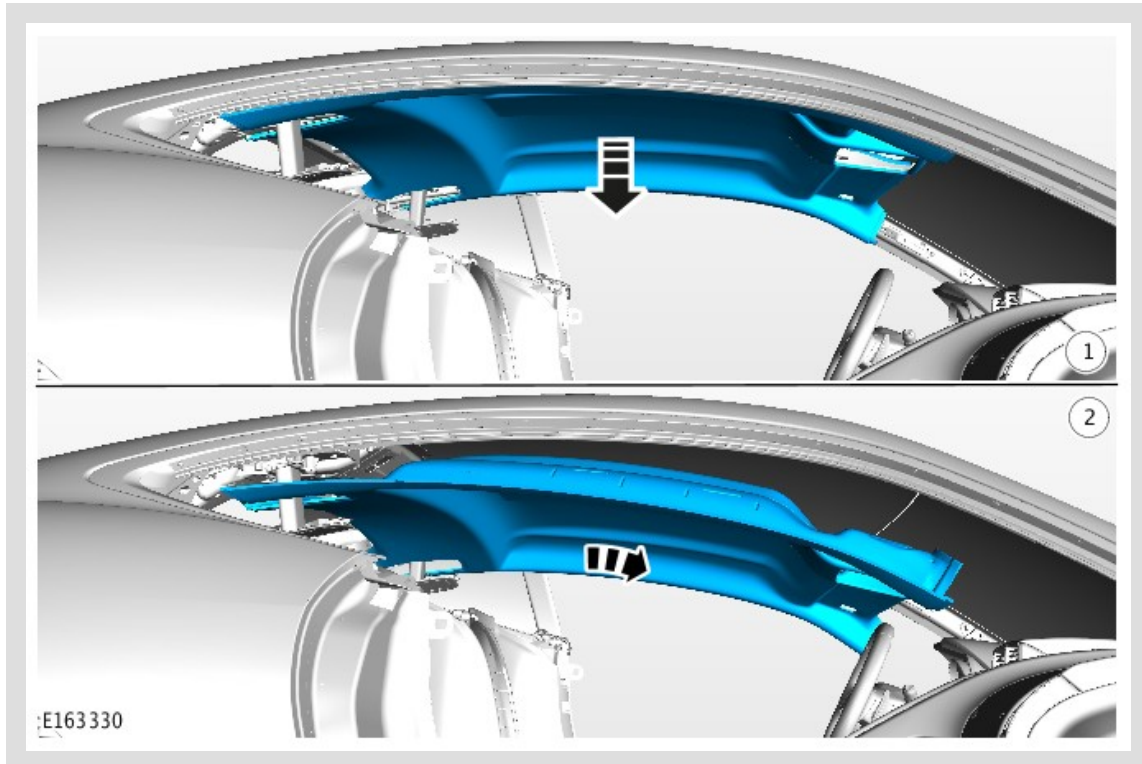

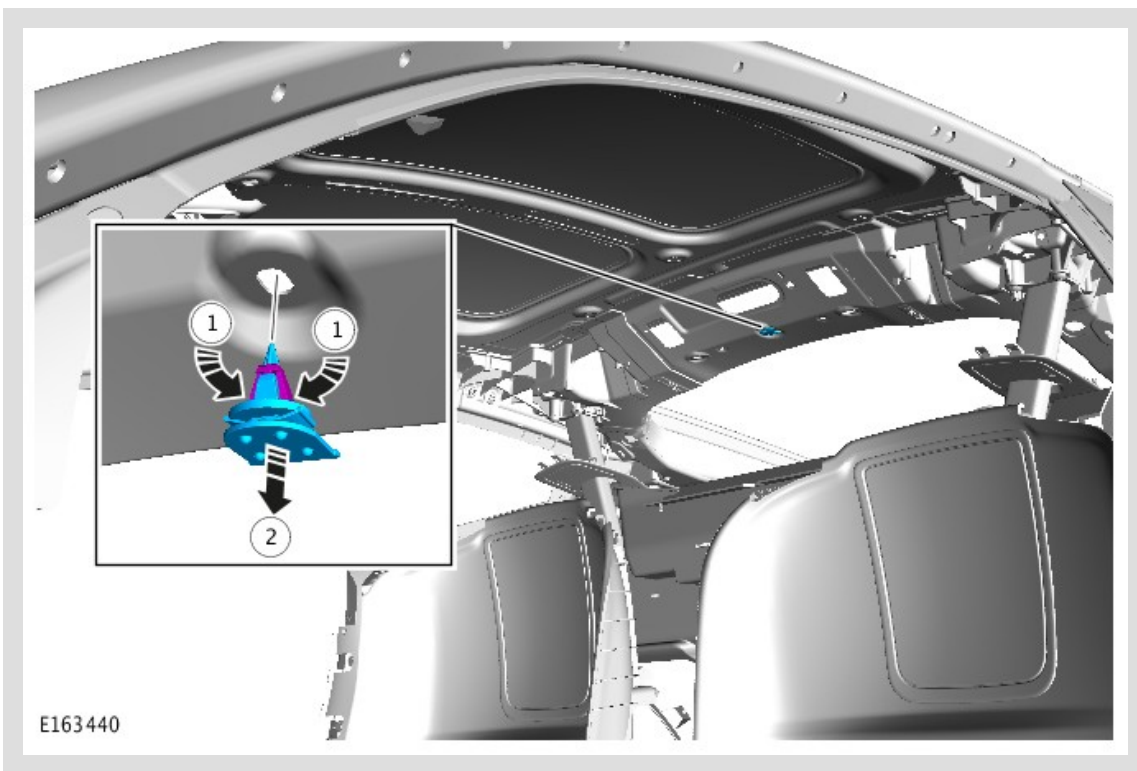

INSTALLATION

1. To install, reverse the removal procedure.

2.

 NOTE:

Install a new retaining clip.

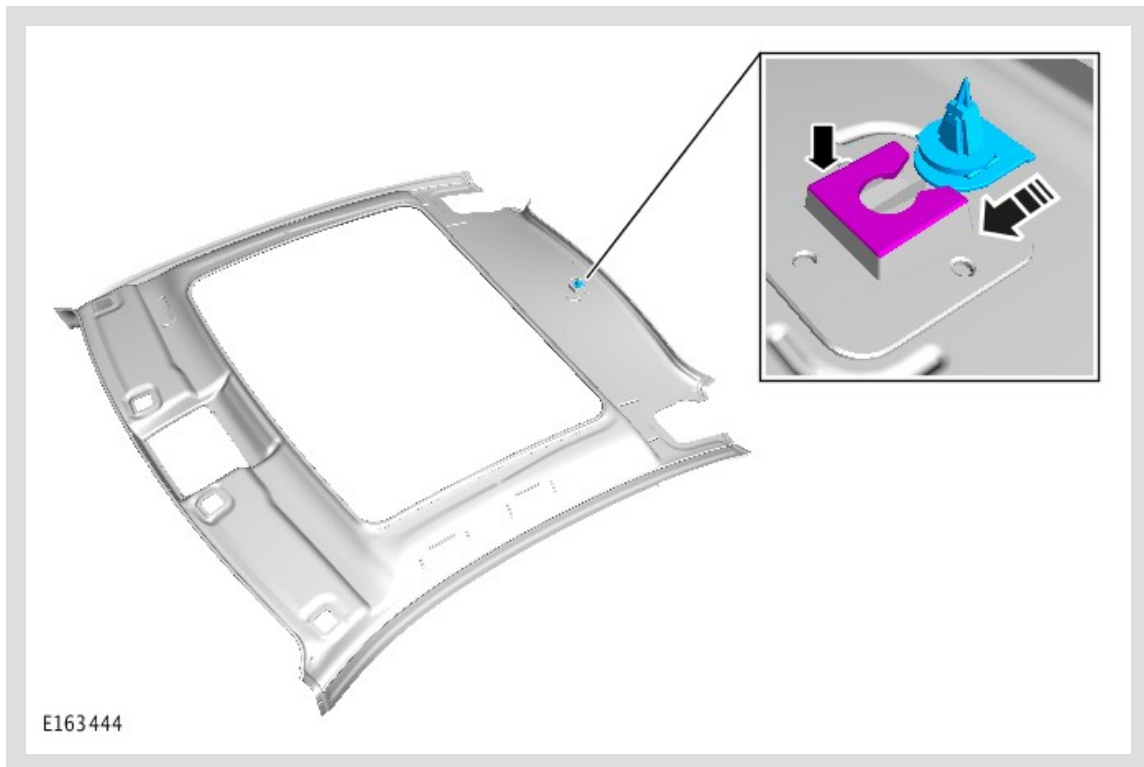

3.

 NOTE:

Make sure that the gap around the component is even.

