

Jaguar AdvanTEK Rear Axle Removal & Installation

Objective

To successfully remove and install a rear differential with a process that is within a home mechanic's capability.

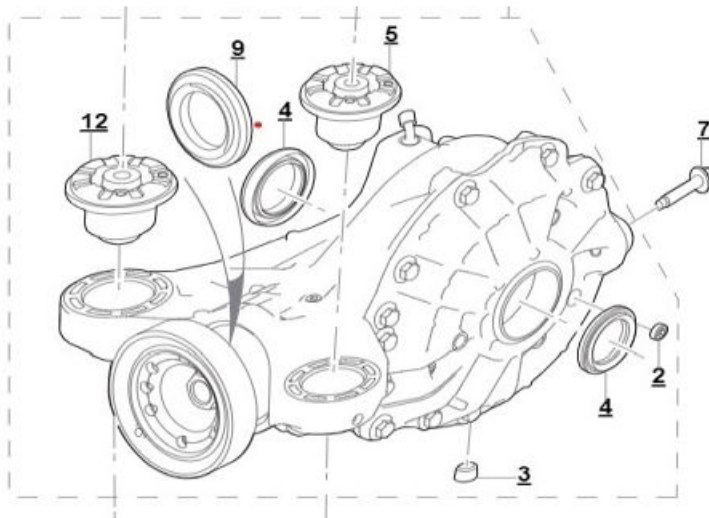

Starting Point

This document describes a simplified process to remove a rear differential, and the reinstallation process. It assumes all other vehicle parts are in good working order and do not need replacement.

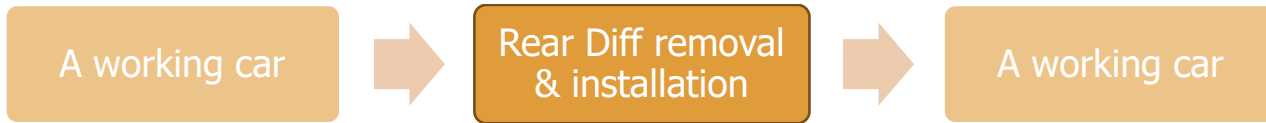

[picture of the rear axle on the ground or dolly]

Jaguar Applications

This document is primarily for the Jaguar F-Types V6 S/C, from 2013 to 2020. The V8 F-Types with electronically controlled differential are similar as well as other Jaguar models outside this range.

Simplifications

DRAFT

The following procedure is under development, but it attempts to minimize the number of steps needed to make the rear differential swap. Overly cumbersome steps were eliminated as well as the need for special tools. A key simplification may require that two holes be cut into the rear cargo bay floor to access two mounting bolts on the rear side of the differential. This is to save several hours of labor and the use of specialized sub frame jacking equipment.

Preparations

To prepare for the Rear Axle swap, the following items are recommended.

- Tools
 - Floor jack to raise the vehicle, and support the differential
 - Jack stands to support the vehicle
 - Ratchet set and assorted deep or shallow sockets
 - Assorted Wrenches
 - Torque Wrench up to 160 [Nm] , 120 [ft-lbs]
- Materials
 - Hypoid Gear Oil
 - Thread locking compound ??
 -
- Parts
 - Driveshaft bolts? x6 Jag part number:
 - Other bolts? xN

Process – Simplified Edition

Disassembly

1. Raise the rear of the vehicle, and place on jack stands
 - a. Raise rear of vehicle so differential housing is at least 30 cm above ground level
 - b. Locate the jack stands forward of the rear axle brace bolts

[Picture Here of jack stand location]

2. Remove the rear tires and inner rocker panel shields
 - a. Remove plastic push tabs (x11 per side)

[Picture of tire and shield removed]

3. Drain the rear differential case of oil
4. Remove the rear half shafts from differential (apply to both sides of vehicle)
 - a. Keep half shaft nut fastened to wheel hub (no need to remove this)
 - b. Remove rear brake caliper and brake rotor (hang caliper to one side)
 - c. Release tie rod arm from wheel hub
 - d. Release upper control arm from wheel hub (two wrench method)
 - e. Loosen lower control arm bolt (may not need to remove this bolt)
 - f. Pull wheel hub and axle half shaft assembly away from Differential

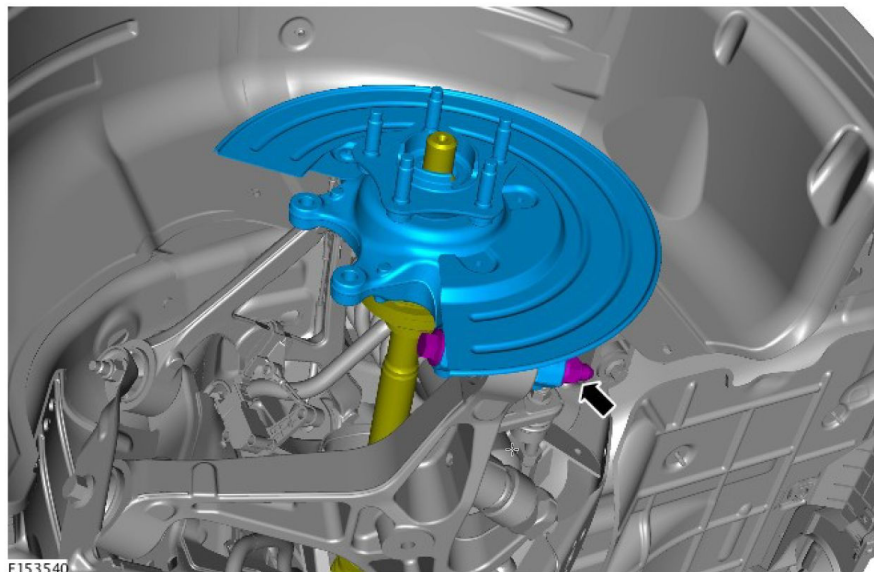

E153540

5. Remove the rear exhaust system
6. Remove the rear under shield (x7 clips, fasteners)
7. Remove the rear suspension support brace (x10 total fasteners)
8. Remove the driveshaft rear heat shield (x4 fasteners)
9. Disconnect the driveshaft from the rear differential input flange (x6 bolts)
 - a. Support the driveshaft to prevent damage to the center carrier
10. Remove the rear suspension cross brace (x10 fasteners)
11. Remove the rear mounting bolts to the differential
 - a. Use special low profile tool for M14 bolts (XX mm socket or tool 204-477)
 - b. The rear bolts may have minimal clearance with the cargo bay floor
 - c. Option: cut two holes in rear cargo bay floor to access rear bolts

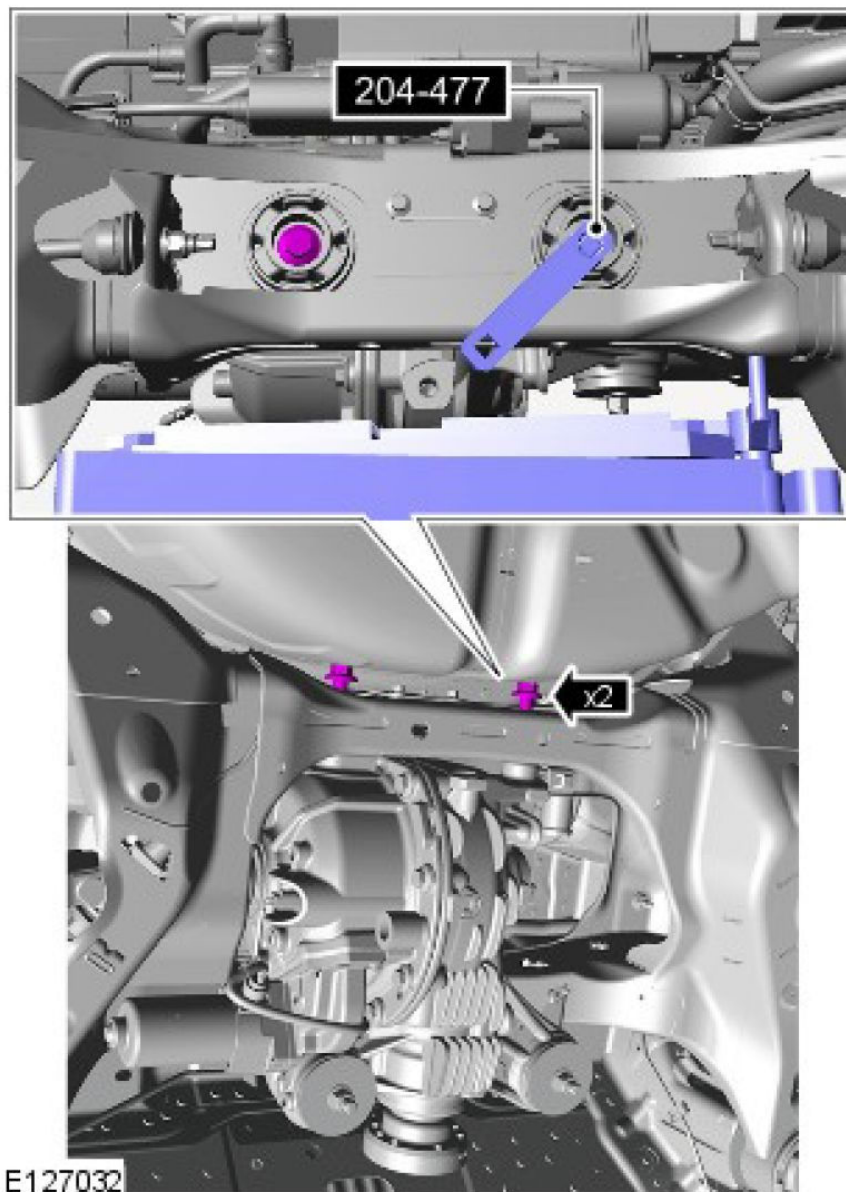

12. Support the rear differential (75 lbs) with a floor jack or equivalent
13. Remove the front mounting bolts to the differential (15mm hex bolts)

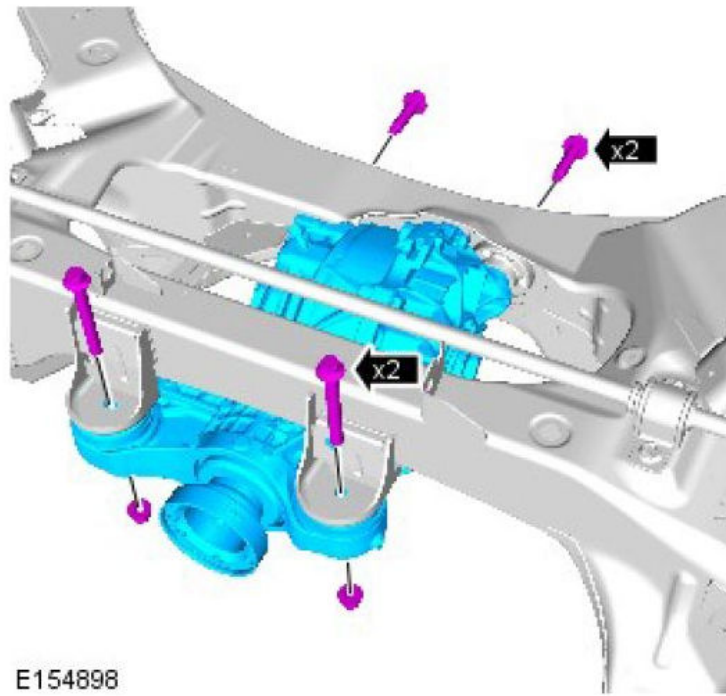

14. Lower the rear differential from the vehicle
 - a. Locate and save the breather cap from the top of the differential

Reassembly

The reverse of Disassembly

- Install rebuilt rear differential into subframe with assistance of a floor jack
 - front mounting bolt torque = 90 Nm
 - rear mounting bolt torque = 160 Nm
- Install rear suspension cross brace
 - Torx bolts = 25 Nm
 - M10 bolts = 45 Nm
- Reconnect driveshaft to rear differential
 - Bolts = 75 Nm (x6 renew)
- Install the rear suspension support brace
 - Torx bolts = 25 Nm
 - M10 bolts = 45 Nm
- Install the rear undershield
 - torque = 10 Nm ?? clips
- Install rear exhaust components
- Insert the halfshafts into the rear differential
 - Reposition the wheel hub and halfshafts
 - Connect upper control arm to wheel hub (two wrench method)
 - Connect tie rod to wheel hub
 - Connect brake rotor and caliper
 - Tighten the lower control arm bolt and all others attached to the hub
- Install rocker panel moldings
- Install wheels
- Patch rear cargo bay holes ... rivets and aluminum

Fill Differential with Oil

- Use 1 liter bottle with hand pump
 - GL-5 synthetic gear oil or Castrol BOT 750B or equivalent, quantity 0.85 liters
 - No friction modifiers for the helical rear diff.

Other Jaguar Models

- All have similar rear suspension cradles and mounting methods
- The amount of spacing or room may be more generous than the F-Type.

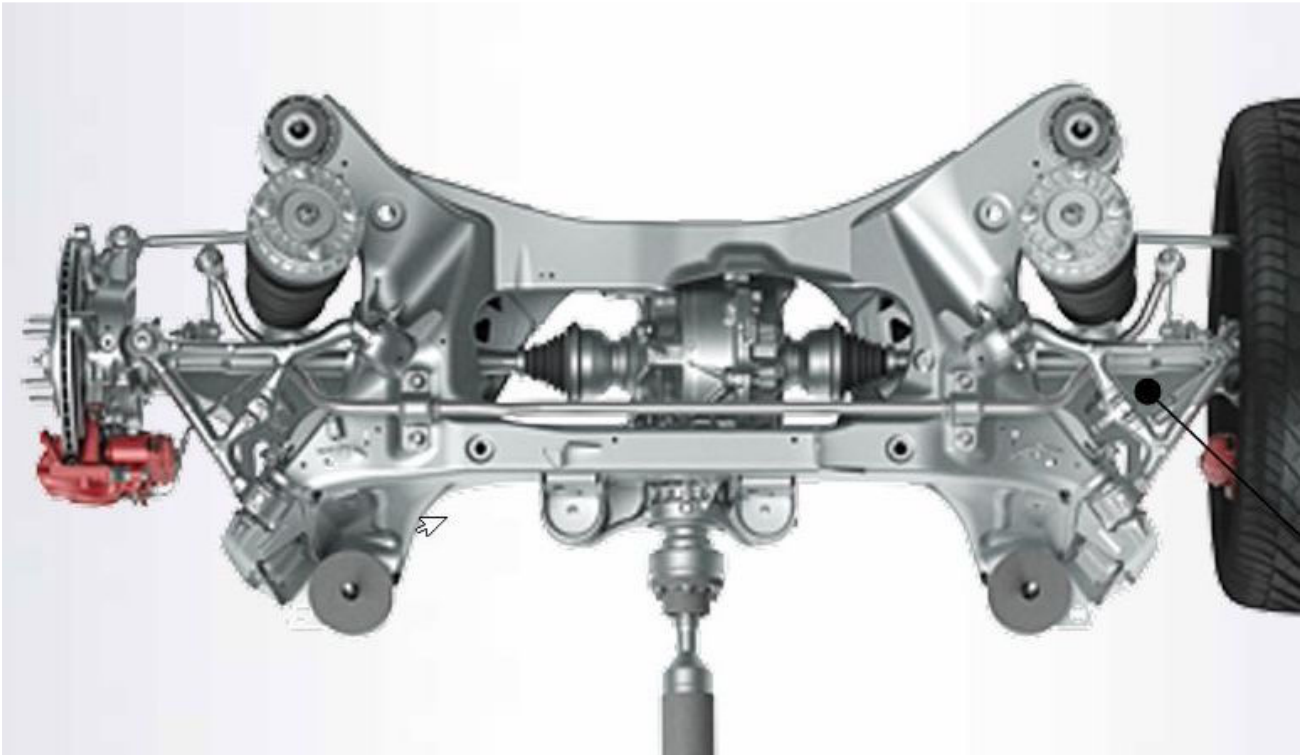

Figure 1. Top down view of F-Type V6 rear suspension assembly with highlights.

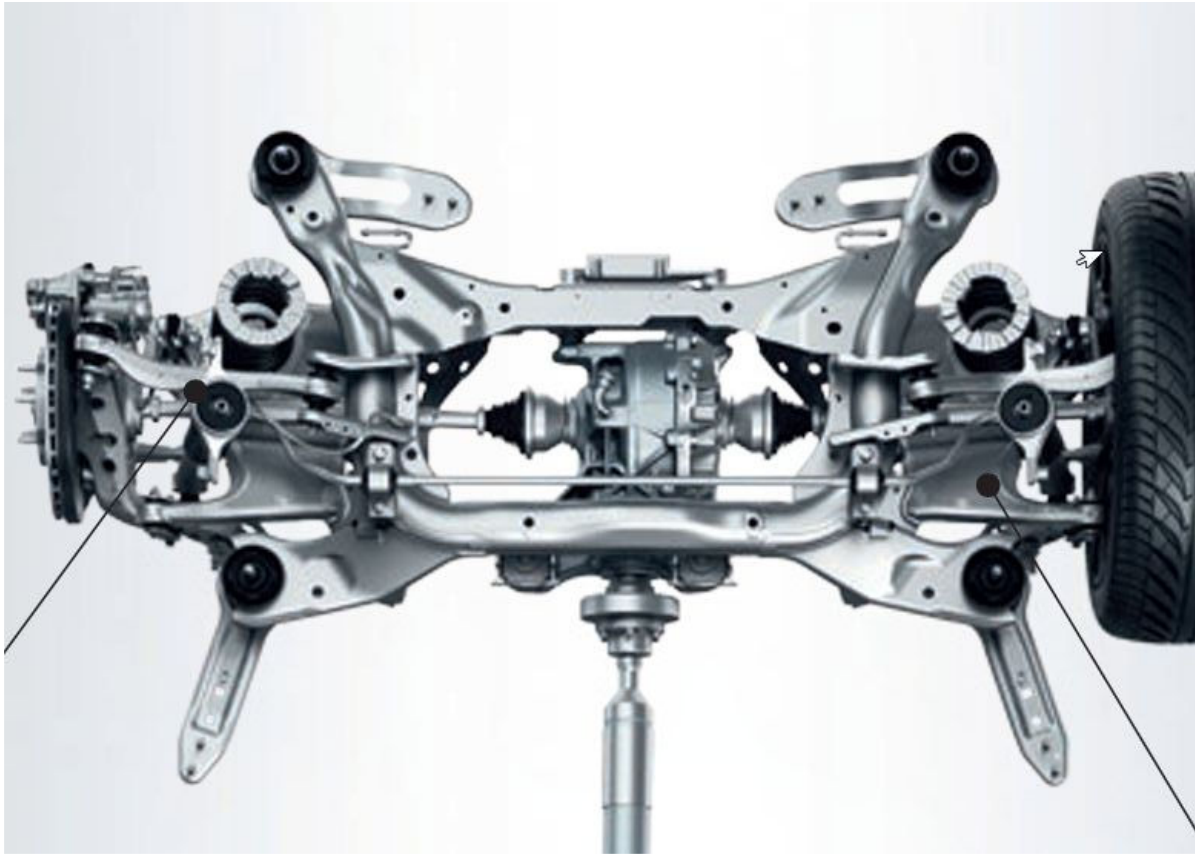

Figure 2. Top down view of XE/XF V6 rear suspension assembly with highlights.