

2015.0 F-TYPE (X152), 204-04

WHEELS AND TIRES

TIRE PRESSURE MONITORING SYSTEM (TPMS) RECEIVER (G1580074)

REMOVAL AND INSTALLATION

86.62.44	TIRE PRESSURE MONITORING SYSTEM (TPMS) MODULE - RENEW	ALL DERIVATIVES	0.9	USED WITHINS
----------	---	--------------------	-----	-----------------

REMOVAL

NOTE:

Removal steps in this procedure may contain installation details.

1.

NOTE:

Repeat the procedure for the other side.

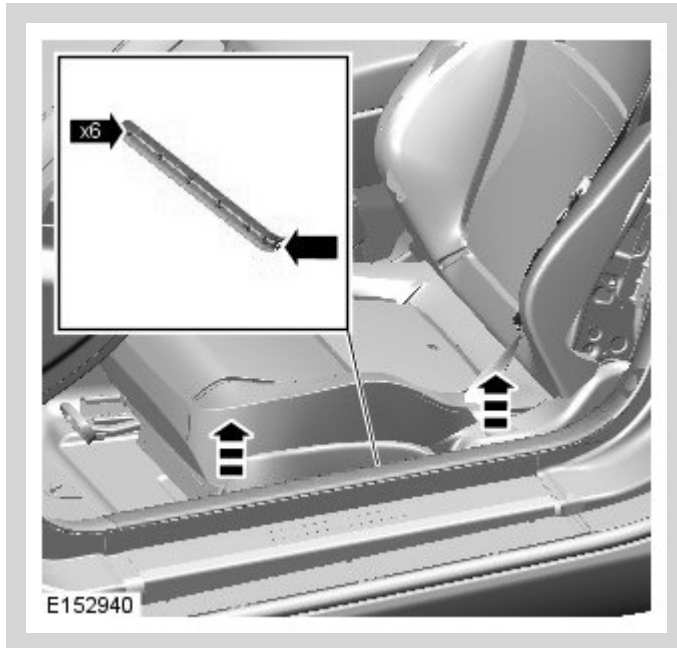

2.

△ NOTE:

Repeat the procedure for the other side.

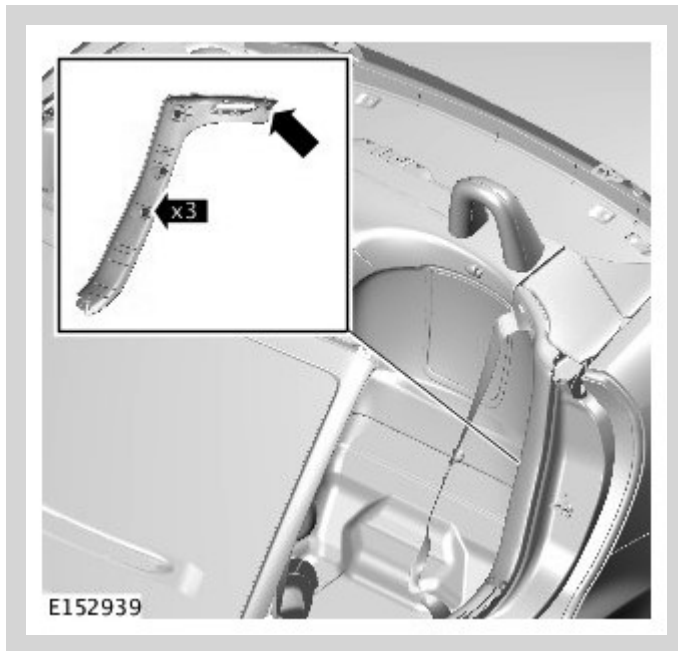

3.

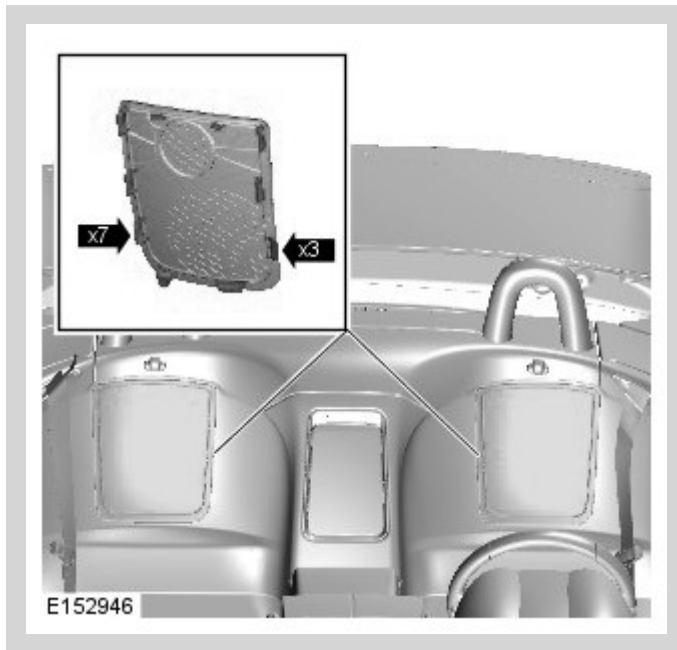

4.  **NOTE:**

Repeat the procedure for the other side.

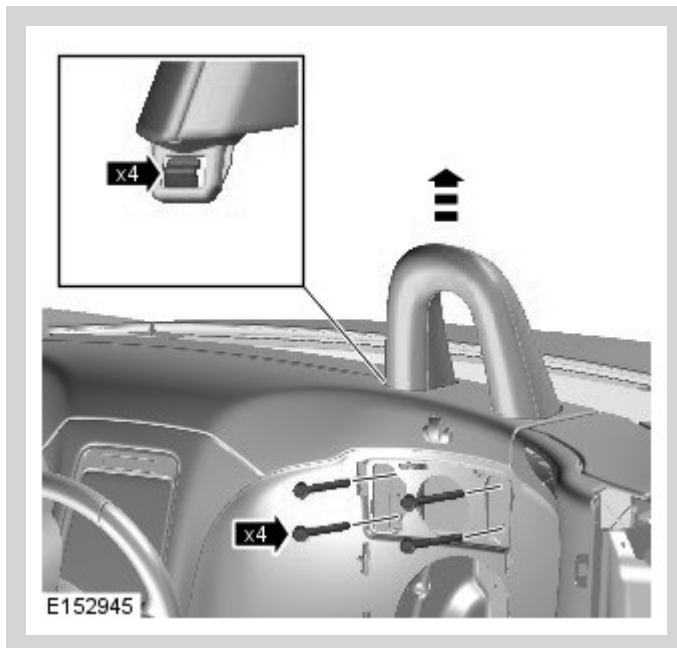

Torque: 45 Nm

5.



6.

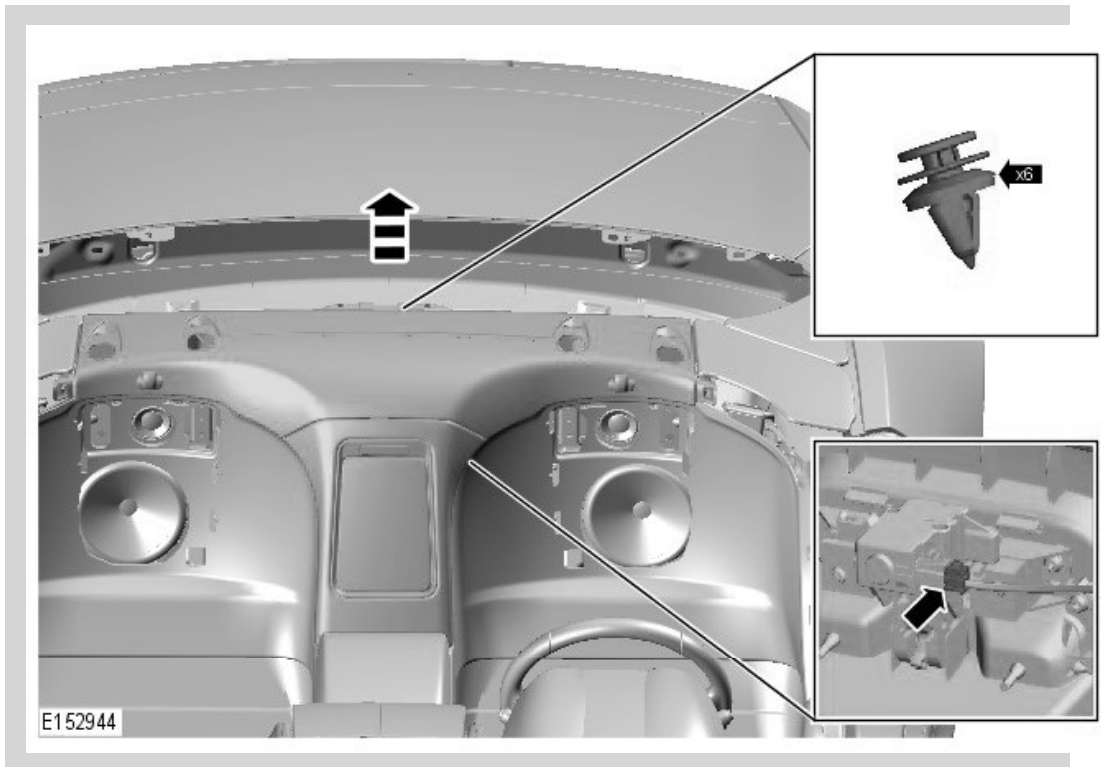

7.

⚠ CAUTION:

Detach the receiver from the bracket by releasing the velcro.

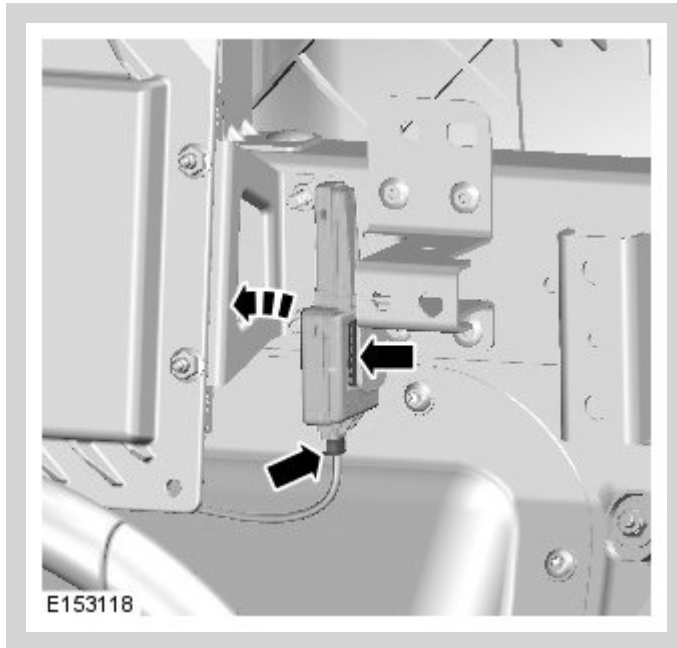

INSTALLATION

1. To install, reverse the removal procedure.
2. If a new component has been installed, configure using Jaguar approved diagnostic equipment.