

Driver's Handbook

JAGUAR CARS LIMITED, as manufacturers, are dedicated to the design and production of vehicles which meet the expectations of the world's most discerning purchasers.

To complement the features, systems and technology of your new vehicle we have produced this Driver's Handbook. In it we have undertaken to make the control of complex systems easy to understand and operate.

The information contained herein applies to a range of vehicles and not to a specific vehicle. For the specification of a particular vehicle, owners should consult their Jaguar Dealer.

The Manufacturer reserves the right to vary its specifications with or without notice, and at such times and in such manner as it thinks fit. Major as well as minor changes may be involved in accordance with the Manufacturer's policy of constant product improvement.

All rights reserved. No part of this publication may be reproduced, stored in a retrieval system or transmitted, in any form, electronic, mechanical, photocopying, recording or other means without prior written permission from the Service Division of Jaguar Cars Limited.

Contents

1. Introduction

General Information	1-1
Vehicle Literature Brochures	1-2
Mobile/portable telephones	1-3
Regular Servicing	1-3
Warranties (USA and Canada)	1-3
Tyre Information	1-4
Safety Precautions	1-5
Reporting Safety Defects (USA only)	1-5
Safety, Warning and Caution Labels	1-6
Vehicle Identification and Certification Label	1-8
Anti-theft V. I. N. Labels	1-9

2. Security

Key-ring Transmitter	2-2
Key Identification and Locks	2-5
Door locking/unlocking using a black-headed key	2-5
To lock and set the alarm system	2-5
Door Locking System (green-headed 'Valet' key)	2-6
Unlocking	2-6
Interior Door Lock Operation	2-9
Child Safety Locks	2-9
Alarms and Audible Signals	2-10
Security System Features	2-11
Fuel Filler Flap	2-11
Intrusion Sensing (if fitted)	2-12
Battery Back-up Sounder	2-12

3. Instruments - controls

Engine Coolant Temperature (E)	3-1
Warning Lights	3-2
Message Centre	3-8
Warning and Information Messages	3-9
Trip Computer	3-12
Clock	3-15
Park Brake (Handbrake)	3-15
Automatic Transmission	3-16
'J' Gate Selector	3-16
Traction Control	3-20
Cruise (Speed) Control (where fitted)	3-21
Exterior Lighting	3-23
Headlamp Main Beam (High Beam)	3-24
Fog Lamps (A and B)	3-25
Direction Indicators	3-25
Interior Lighting	3-27
Window Operation	3-29
Horns	3-30
Windscreen Wiper and Washers	3-31
Headlamp Powerwash (where fitted)	3-32
Audible Warnings	3-33

4. Pre-driving

Front Seats and Head Restraints - Adjustment	4-1
Seat Heaters (where fitted)	4-2
Driving Position Memory System (where fitted)	4-3
Steering Column Tilt and Reach Adjustment	4-6
Electrical Operation	4-6
Rear View Mirrors	4-7
Interior Rear View Mirror	4-8
Ignition/Starter Switch and Steering Lock	4-8
To Disengage Steering Lock and Start Engine	4-9
Fuel Cut-off Switch	4-10
Fuel Filler Flap and Cap	4-11
Fuel Filler Flap Manual Lock/Unlock	4-11
Fuel Tank Filling	4-12
Fuel Requirements	4-12
Occupant Protection – Seat Belts and Airbags	4-14
Rear Seat Belts Fitting	4-16
Airbags	4-18
Child Safety	4-20
Child Restraint Tether Anchorages	4-22
Garage Door Opener (GDO)	4-24

5. Driving

General Driving Information	5-1
Winter Driving	5-2
Running-in	5-2
Brakes	5-3
Anti-lock Braking System (ABS plus)	5-3
Touring	5-5
Towing a Caravan or Trailer	5-6

6. Climate control

Control Panel	6-1
General Information	6-1
System Operation and Button Functions	6-2
Operating Tips	6-5
Air Distribution	6-5
System Fault Display	6-5

7. Interior features

Ashtrays and Cigar Lighters	7-1
Glove Compartment	7-3
Sun-glasses Stowage Compartment	7-3
Centre Console Armrest	7-3
Sun Visors and Vanity Mirrors	7-3
Cupholder (where fitted)	7-3
Picnic Trays (where fitted)	7-4
Rear Centre Armrest	7-4

8. Exterior features

Sunroof (where fitted)	8-1
Sunroof – Manual Operation	8-2

A comprehensive index is located at the back of this handbook.

Driver's Handbook

JAGUAR CARS LIMITED, as manufacturers, are dedicated to the design and production of vehicles which meet the expectations of the world's most discerning purchasers.

To complement the features, systems and technology of your new vehicle we have produced this Driver's Handbook. In it we have undertaken to make the control of complex systems easy to understand and operate.

The information contained herein applies to a range of vehicles and not to a specific vehicle. For the specification of a particular vehicle, owners should consult their Jaguar Dealer.

The Manufacturer reserves the right to vary its specifications with or without notice, and at such times and in such manner as it thinks fit. Major as well as minor changes may be involved in accordance with the Manufacturer's policy of constant product improvement.

All rights reserved. No part of this publication may be reproduced, stored in a retrieval system or transmitted, in any form, electronic, mechanical, photocopying, recording or other means without prior written permission from the Service Division of Jaguar Cars Limited.

Contents

1. Introduction

General Information	1-1
Vehicle Literature Brochures	1-2
Mobile/portable telephones	1-3
Regular Servicing	1-3
Warranties (USA and Canada)	1-3
Tyre Information	1-4
Safety Precautions	1-5
Reporting Safety Defects (USA only)	1-5
Safety, Warning and Caution Labels	1-6
Vehicle Identification and Certification Label	1-8
Anti-theft V. I. N. Labels	1-9

2. Security

Key-ring Transmitter	2-2
Key Identification and Locks	2-5
Door locking/unlocking using a black-headed key	2-5
To lock and set the alarm system	2-5
Door Locking System (green-headed 'Valet' key)	2-6
Unlocking	2-6
Interior Door Lock Operation	2-9
Child Safety Locks	2-9
Alarms and Audible Signals	2-10
Security System Features	2-11
Fuel Filler Flap	2-11
Intrusion Sensing (if fitted)	2-12
Battery Back-up Sounder	2-12

3. Instruments - controls

Engine Coolant Temperature (E)	3-1
Warning Lights	3-2
Message Centre	3-8
Warning and Information Messages	3-9
Trip Computer	3-12
Clock	3-15
Park Brake (Handbrake)	3-15
Automatic Transmission	3-16
'J' Gate Selector	3-16
Traction Control	3-20
Cruise (Speed) Control (where fitted)	3-21
Exterior Lighting	3-23
Headlamp Main Beam (High Beam)	3-24
Fog Lamps (A and B)	3-25
Direction Indicators	3-25
Interior Lighting	3-27
Window Operation	3-29
Horns	3-30
Windscreen Wiper and Washers	3-31
Headlamp Powerwash (where fitted)	3-32
Audible Warnings	3-33

4. Pre-driving

Front Seats and Head Restraints - Adjustment	4-1
Seat Heaters (where fitted)	4-2
Driving Position Memory System (where fitted)	4-3
Steering Column Tilt and Reach Adjustment	4-6
Electrical Operation	4-6
Rear View Mirrors	4-7
Interior Rear View Mirror	4-8
Ignition/Starter Switch and Steering Lock	4-8
To Disengage Steering Lock and Start Engine	4-9
Fuel Cut-off Switch	4-10
Fuel Filler Flap and Cap	4-11
Fuel Filler Flap Manual Lock/Unlock	4-11
Fuel Tank Filling	4-12
Fuel Requirements	4-12
Occupant Protection – Seat Belts and Airbags	4-14
Rear Seat Belts Fitting	4-16
Airbags	4-18
Child Safety	4-20
Child Restraint Tether Anchorages	4-22
Garage Door Opener (GDO)	4-24

5. Driving

General Driving Information	5-1
Winter Driving	5-2
Running-in	5-2
Brakes	5-3
Anti-lock Braking System (ABS plus)	5-3
Touring	5-5
Towing a Caravan or Trailer	5-6

6. Climate control

Control Panel	6-1
General Information	6-1
System Operation and Button Functions	6-2
Operating Tips	6-5
Air Distribution	6-5
System Fault Display	6-5

7. Interior features

Ashtrays and Cigar Lighters	7-1
Glove Compartment	7-3
Sun-glasses Stowage Compartment	7-3
Centre Console Armrest	7-3
Sun Visors and Vanity Mirrors	7-3
Cupholder (where fitted)	7-3
Picnic Trays (where fitted)	7-4
Rear Centre Armrest	7-4

8. Exterior features

Sunroof (where fitted)	8-1
Sunroof – Manual Operation	8-2

A comprehensive index is located at the back of this handbook.

Contents

General Information

Regular maintenance and servicing is the responsibility of the owner.

Regular routine maintenance not only helps to prevent unnecessary 'breakdowns' and inconvenience, but enhances the 'remarketing' or resale value of the vehicle.

When left-hand or right-hand is used in the text, this refers to the left-hand side or right-hand side of the vehicle, viewed from the rear.

Jaguar Diagnostic System

Many of the vehicle systems are controlled by complex electronic devices. Specialist equipment is required to trace and rectify faults in the systems and ensure that only faulty components are repaired or renewed.

Caution: Severe damage to the electrical system and electronic components can occur if any attempt is made to diagnose faults in the electrical system using conventional diagnostic equipment (for example, the use of test lamps or low impedance voltmeters). The fitting of any electrical accessory should only be entrusted to a Jaguar Dealer.

Accessories

A full range of Jaguar Engineering approved accessories including safety, stowage, touring, leisure and lifestyle products are just some of those available from your Jaguar Dealership.

Please ask your Jaguar Dealer for an up-to-date brochure so you can select your requirements from the latest range.

Jaguar Dealers

Jaguar Dealers are chosen with care. Each is dedicated to providing a Sales, Service and Spare Parts facility of the highest standard.

Jaguar Dealers are provided with full technical support from the factory, with comprehensive training for all their technicians. Dealers' workshops operate to a high standard and have all the necessary tools and equipment essential to maintain or repair Jaguar vehicles.

Genuine Jaguar Parts and Accessories

Your Jaguar Dealer can supply you with genuine replacement parts and accessories which are fully approved to Jaguar's original equipment specification. This will ensure that the safety and performance of your vehicle is maintained for your complete peace of mind.

Please note that fitment of non-genuine parts may invalidate the vehicle warranty if a subsequent fault occurs due to fitting sub-standard replacement parts or accessories.

Jaguar Parts Distribution Service

Jaguar Dealers stock a large number of parts to keep your vehicle maintained and back on the road as quickly as possible. Their service is backed-up by Jaguar's central parts warehouse in Coventry, England, providing next day delivery to most of Europe's Dealers and world-wide within two to three days.

1-2 Introduction

Locking Wheel Nuts

In certain markets vehicles are fitted with locking wheel nuts as standard. See **Wheel Changing and Jacking** in SECTION 4 of the Vehicle Care Handbook.

For other vehicles, locking wheel nuts are available as an accessory. These may vary from the type of locking wheel nut fitted as standard.

After fitting, wheel re-balancing may be necessary and subsequently the locking nut must always be fitted in the same position.

Vehicle Literature Brochures

The vehicle literature is in two separate packs within the vehicle.

Driver Literature Pack

This pack is in the front passenger's glove compartment and comprises the following:

Driver's Handbook.

Audio System Handbook.

Navigation Handbook (When navigation system is fitted).

Quick Reference Guide.

Vehicle Care Literature Pack

This pack is in the luggage compartment and comprises the following:

Vehicle Care Handbook.

Passport to Service Booklet (Except Mexico)

Service and Record Warranty Book (Mexico only)

Fuel

See **Fuel Tank Filling** on page 4-12 and also **Fuel Requirements** in SECTION 6 of the Vehicle Care Handbook.

'PREMIUM UNLEADED FUEL ONLY' is clearly marked adjacent to the fuel filler cap.

Electrical Accessories

The fitting of any electrical accessory **should only** be entrusted to a Jaguar Dealer. See **Electrical Accessories** in SECTION 7 of the Vehicle Care Handbook. This information must be observed before fitting any accessories.

Regular Checks

In the interests of safety and reliability, it is advisable to carry out checks at regular intervals, i.e. daily, weekly and monthly. Always check the vehicle thoroughly before starting on a long journey.

See **Regular Checks** in SECTION 3 of the Vehicle Care Handbook.

Emergency Starting

Vehicles with automatic transmissions cannot be tow started. See **Emergency Starting** in SECTION 4 of the Vehicle Care Handbook.

Window Marking

A worthwhile precaution is to have the vehicle registration number etched into each window glass by a Jaguar Dealer.

Mobile/portable telephones



WARNING:

Using a mobile/portable telephone without an exterior antenna is not recommended when driving as the electro-magnetic fields produced can cause malfunctions with the vehicle electronic systems.

Check the laws and regulations on the use of cellular telephones in the areas where you drive. Always obey them. Also, give full attention to driving.

Use hands-free operation (if fitted) and pull off the road and park before making or answering a call if driving conditions so require.

Regular Servicing

Each vehicle is given a full 'Pre-delivery Inspection' to ensure that all systems function correctly and the vehicle meets its specification.

Failure to carry out maintenance at the recommended intervals could result in deterioration of the vehicle performance and possible infringement of regulations.

USA and Canada: Jaguar Dealers will arrange for appointments on a mileage/distance or time interval basis to ensure that all routine and corrective maintenance work is undertaken and recorded in the 'Passport to Service' Booklet. This booklet not only contains a record of vital information, but also information about warranties, Jaguar Cars, Jaguar Car Clubs, Tyre Manufacturers and change of ownership or address vouchers.

Mexico: Jaguar Dealers will arrange for appointments on a mileage/distance or time interval basis to ensure that all routine and corrective maintenance work is undertaken and recorded in the Service Record and Warranty Book. This booklet not only contains a record of vital information, but also information about warranty and a change of ownership card.

Warranties (USA and Canada)

The 'Passport to Service' Booklet contains warranties applicable to the vehicle, which include:

- The Limited Vehicle Warranty.
- The Emission Control System Warranty and covered parts list.
- The Corrosion Warranty.

Note: Tyres are not warranted by Jaguar Cars, but by the specific manufacturer of the tyres on the vehicle. Details of tyre warranties are included in the vehicle literature pack.

Warranties (Mexico)

The Service Record and Warranty Book contains warranties applicable to the vehicle, which include:

- The Limited Vehicle Warranty.
- The Emission Control System Warranty and covered parts list.
- The Corrosion Warranty.

1-4 Introduction

Tyre Information

All tyres fitted to vehicles sold in the USA and Mexico have data, necessary to conform to the USA Federal Regulations, moulded onto the tyre.

The data on the tyres gives the following information;

Maximum Pressure.

Maximum Load Rating.

Further information is given on the tyre recommendation label located on the underside of the centre console storage compartment lid as follows;

Vehicle Capacity Weight.

Designated Seating Capacity.

Designated Seating Distribution.

Recommended Tyre Pressures.

Recommended Tyre Size.

Take particular note of **WARNINGS** and **Cautions** given throughout this handbook.



WARNING:

Procedures which must be followed precisely to help avoid the risk of personal injury.

Caution: Procedures which must be followed precisely to reduce the possibility of damage to the vehicle and resultant risk of personal injury or inconvenience.

Warning symbols on the vehicle

On encountering the warning triangle or open book symbol on the vehicle, it is important that you consult the relevant section of this handbook and the Vehicle Care Handbook before touching this part of the vehicle or attempting adjustments of any kind.

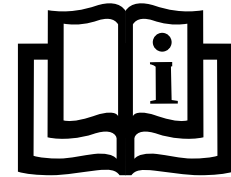

Safety Precautions



WARNING:

- 1. Many liquids and other substances used in vehicles are poisonous and should never be consumed and must be kept away from open wounds. These substances include anti-freeze, brake fluid, fuel, windscreen washer additives, lubricants and various adhesives.**
- 2. The presence of any unusual fumes (e.g. petrol or exhaust fumes) in the passenger compartment and/or luggage compartment should be corrected immediately by a Jaguar Dealer. If you must drive under these conditions do so only with all windows fully open.**
- 3. Any modifications to the fuel system not specifically designed for this Jaguar are prohibited. Such modifications in some circumstances could result in a fire. All service actions must be entrusted to a Jaguar Dealer.**
- 4. Alterations to the electrical system, including the fitting of accessories not designed for this Jaguar, will cause damage to the electrical circuits and systems. In some circumstances this could result in a malfunction or fire. All accessory work should be entrusted to a Jaguar Dealer.**
- 5. No attempt should be made to repair a fuse that has blown. Always install a fuse of the correct amperage (see Fuse Ratings and Circuits in SECTION 4 of the Vehicle Care Handbook). Failure to comply with the above may cause a fire hazard or serious damage elsewhere in the electrical circuit.**

Reporting Safety Defects (USA only)

If you believe your vehicle has defect which could cause a crash or could cause injury or death, you should immediately inform the National Highway Traffic Safety Administration (NHTSA) in addition to notifying Jaguar Cars.

If NHTSA receives similar complaints, it may open an investigation, and if it finds that a safety defect exists in a group of vehicles, it may order a recall and remedy campaign. However, NHTSA cannot become involved in individual problems between you, your Dealer, or Jaguar Cars.

To contact NHTSA, you may either call the Auto Safety Hotline toll-free at 1-800-424-9393 (or 355-0123 in Washington, D.C. area) or write to: NHTSA, U.S. Department of Transportation, Washington, D.C. 20590.

To contact Jaguar Cars, call (201) 818-8100.

You can also obtain other information about motor vehicle safety from the Hotline.

1-6 Introduction

Safety, Warning and Caution Labels

Note: Do not remove any safety, caution or warning labels from the vehicle.

Braking System (A)

The brake fluid caution symbol is moulded into the master cylinder filler cap.

Brake system warning information is moulded into the master cylinder reservoir and states:

WARNING – CLEAN FILLER CAP BEFORE REMOVING. USE ONLY JAGUAR SUPER DOT 4 BRAKE FLUID FROM A SEALED CONTAINER.

Power Steering System (B)

The label is located on the reservoir filler cap and states: **WARNING.**

See **Checking and Replenishment** in SECTION 3 of the Vehicle Care Handbook for information on topping up the power steering system.

Cooling System (C)

The header tank label is located on the filler cap and states: **WARNING – DO NOT OPEN WHEN HOT.**

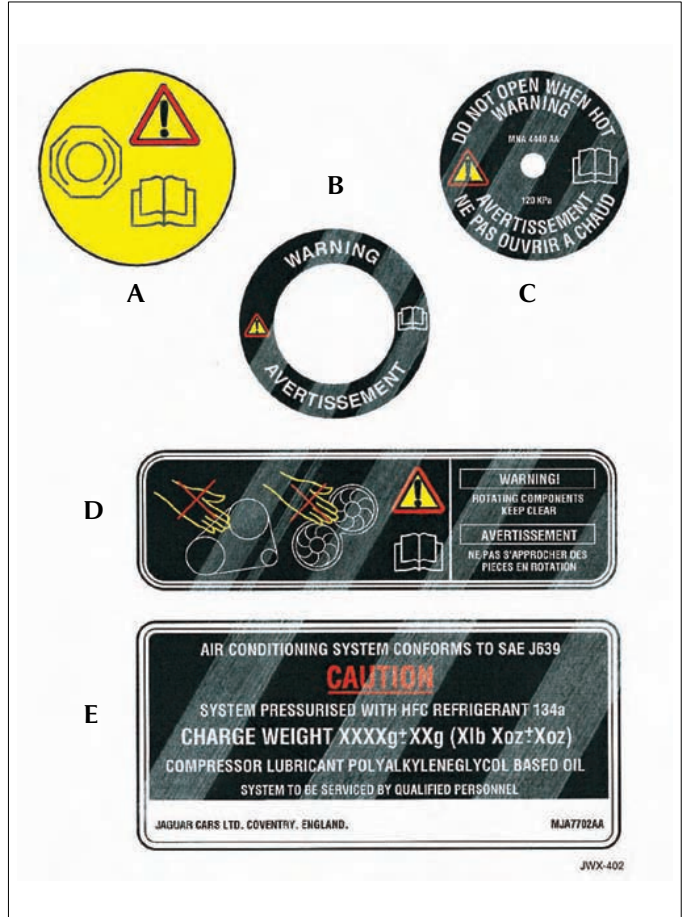

1-7 Introduction

Rotating Components (D)

A label is located on the fan shroud and states:

WARNING – ROTATING COMPONENTS – KEEP CLEAR.

Climate Control System (E)

The label located under the bonnet on the left-hand side states:

CAUTION – System pressurised with HFC Refrigerant 134a.
System to be serviced by qualified personnel.

Warning and Information Messages

Warning and information messages are displayed on the message centre which is located within the speedometer.

As well as odometer and trip computer information, status and warning messages may be displayed (along with a red or amber priority indicator to show the type of message), to alert the driver to a situation or vehicle status which may require attention.

Throughout the Handbook, references to messages are made as shown in the example below:

Message: **Hood Open** Priority Indicator: **Red**

1-8 Introduction

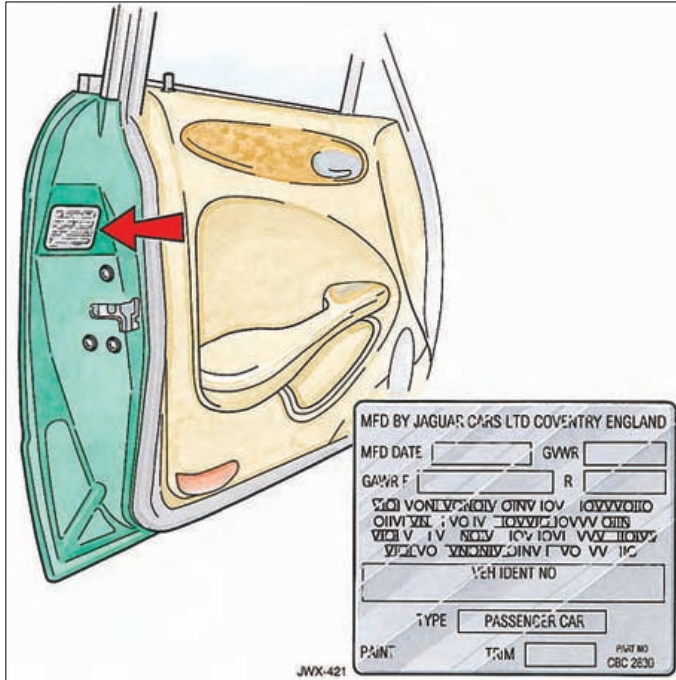

GVWR – Gross vehicle weight rating.

GAWR F – Gross front axle weight rating.

GAWR R – Gross rear axle weight rating.

Paint – Paint code.

Trim – Trim code.

Vehicle Identification and Certification Label

The USA, Canadian and Mexican Certification label is adhered to the left-hand front door shut face below the door lock assembly and is visible when the door is opened.

The label indicates the month and year of manufacture and the Vehicle Identification Number (VIN), it also provides paint and trim codes.

It is essential that the Vehicle Identification Number is quoted in all correspondence and when ordering parts.

The number is also on a plate visible through the windscreen and on a bar coded label adhered to the left-hand front door shut face edge.

Engine Number

V8: Stamped on a raised pad on the front of the engine block near the thermostat housing.

Automatic Transmission Number

The number is located on the left-hand side of the automatic transmission casing.

Anti-theft V. I. N. Labels

The anti-theft label is designed to maintain the identity of the vehicle by having the Vehicle Identification Number (V.I.N.) printed onto a special anti-forgery background.

There are 12 labels positioned around the body of the vehicle and one label on the left-hand side of the engine and one label on the automatic transmission casing.

Note: These labels must not be removed.

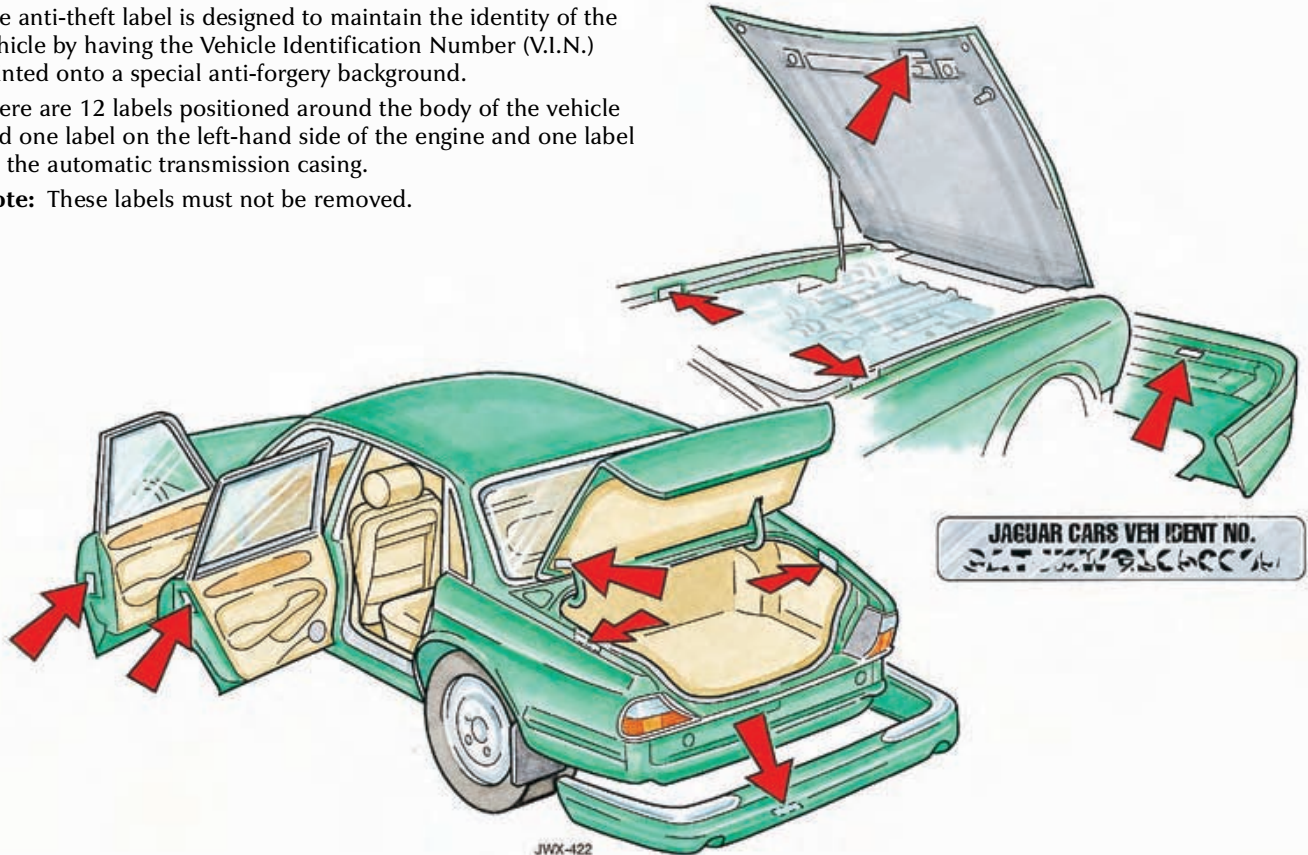

Introduction

Security Design Features

The security system has been designed for:

- Prevention of theft of the vehicle.
- Prevention of theft of items from the vehicle.
- Rapid recovery of the vehicle.
- Personal security.

The security system is integrated with the electronics and engine management systems making it far more difficult for a thief to penetrate and prevents engine starting unless the correct ignition key is used.

Standard alarm features cover the perimeter sensing of hood, doors and luggage compartment.

Passive arming, the automatic alarm system, can be programmed by a Jaguar Dealer. This ensures that the security system arms itself 30 seconds after the doors, hood and luggage compartment are closed following removal of the key from the ignition switch.

Note: Passive arming does not lock the doors.

Vehicle Security

Always remove the ignition key and close and lock the doors when leaving your vehicle unattended, even in your garage or driveway.

At night, try to park in a well lit area as this will discourage intruders and thieves.

Security of Keys and Key-ring Transmitters

It is important to keep your keys and key-ring transmitters in safe places at all times. Leaving them in conspicuous places is an invitation for a thief to steal them and, consequently, your car or belongings. Keep them as secure as you would your wallet or purse, both at home and away. Do not leave the key number tag with the keys, detach the number tag and keep it in a safe place.

For increased security, replacement keys are only obtainable from a Jaguar Dealer who will ask for proof of vehicle ownership before the key can be ordered from Jaguar Cars Ltd. A log of all enquiries for replacement keys is kept by Dealers and notified to Jaguar Cars Ltd.

2-2 Security

Key-ring Transmitter

The Security System is controlled remotely by a radio frequency, battery-operated key-ring transmitter. The transmitter uses a random encrypted fixed and rolling code each time the system is used. This provides billions of combinations and ensures that the code cannot be copied.

Each of the two transmitters supplied is designed to be attached to a driver's key-ring.

The key-ring transmitter is activated by pointing it towards the vehicle and pressing one of the four operating buttons.

- A. Locks and arms the vehicle.
- B. Unlocks and disarms the vehicle.
- C. One press switches on headlamps for 25 seconds. Three presses starts the Panic Alarm.
- D. Releases luggage compartment lock.

Care of Key-ring Transmitters

The key-ring transmitters must be treated with care and not exposed to extremes of heat, dust, humidity or be in contact with fluids. The batteries are the only serviceable part.

Key-ring Transmitter Loss

If a transmitter is lost or stolen it is advisable to contact your Dealer, without delay, to have the remaining transmitter re-programmed to prevent anyone using the lost transmitter. A new key-ring transmitter can be obtained from your Jaguar Dealer, who will ask for proof of vehicle ownership.

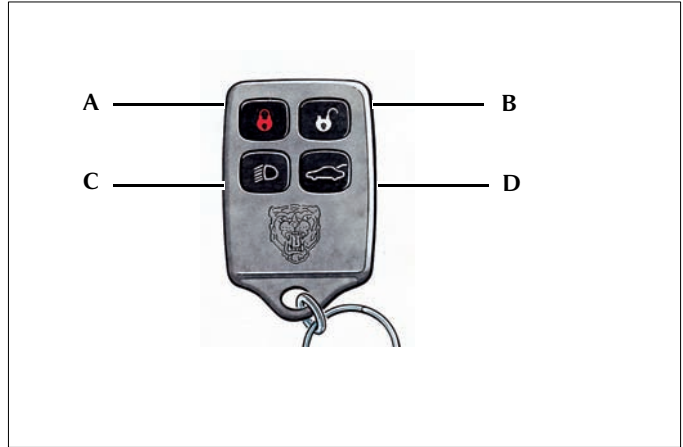

Key-ring Transmitter Operation

The key-ring transmitter will not operate if the key is in the ignition.

The security system will not arm if the key is in the ignition switch or if any protected entry is open.

Caution: The key-ring transmitter may suffer interference from other legal users of this radio frequency band, such as radio amateurs, medical equipment, remote controls or alarm systems. To lock or unlock the vehicle either use a key or operate the key-ring transmitter as close to the security antenna on the rear screen as possible.

Key-ring Transmitter Battery Renewal

To ensure that the key-ring transmitter operates at its full capacity, use CR 2016 batteries. When the batteries need renewal there will be a significant decrease in the effective range of the key-ring transmitter.

Caution: To avoid disrupting the coding of the key-ring transmitter during battery renewal, the operating buttons must not be pressed. If the code is disrupted, it will be necessary to have your Jaguar Dealer re-programme the key-ring transmitters.

To renew the batteries, insert a slim blade into the gap in the casing and prise apart, exposing the twin-disc battery cells. Fit two new cells with the sides marked with the positive symbol (+) downwards into the battery receptacle. Refit the battery cover and click into place with thumb pressure.

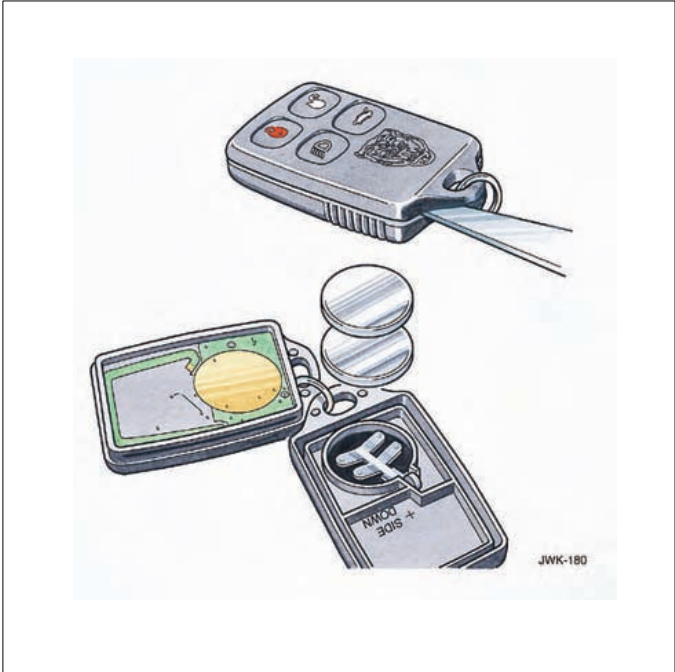

2-4 Security

Key-ring Transmitter Operation – Button Functions

Button A (Locks and arms)

First press (if vehicle is unlocked and disarmed): Locks all doors, the luggage compartment and sets the alarm system. The direction indicators will flash once and a single sound will be heard whilst locking and arming occurs. The red security system warning light in the gear selector panel will start to flash and will continue flashing while the vehicle is armed.

Button B (Unlocks and disarms)

First press: Unlocks the driver's door and the luggage compartment. It disarms the security system alarm and switches on the interior lights for 2 minutes at $\frac{3}{4}$ brightness. It also cancels the luggage compartment valet lock-out, if set. The direction indicators will flash twice and two sounds will be heard as the vehicle is unlocked and disarmed.

Second press: Unlocks the passenger's doors.

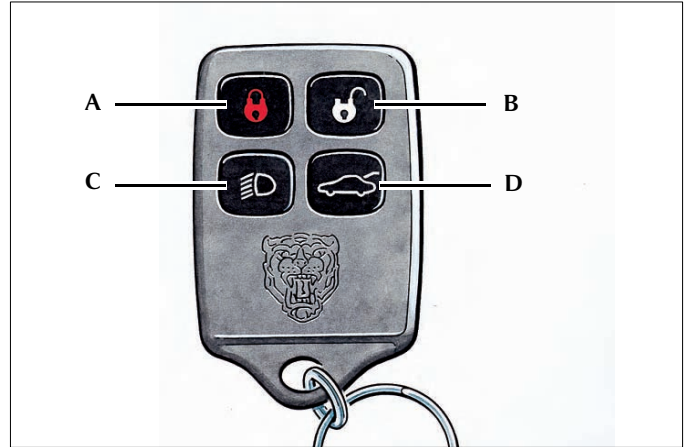

Button C

One press: Switches on headlamps. The headlamps will remain on for 25 seconds, or until the key is inserted in the ignition switch and turned to position 'II', or if the button is pressed again.

Three presses within 3 seconds: Starts Panic Alarm.

Button D

One press: Releases luggage compartment lock.

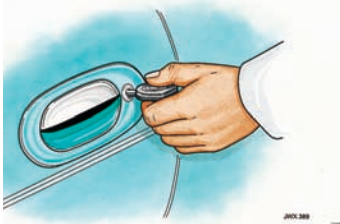

Key Identification and Locks

Key numbers are recorded on plastic tags which are attached to each key. These numbered tags must be detached and kept in a secure place so that correct replacement keys can be obtained.

A set of three keys is supplied with the vehicle; two black-headed keys (one as a spare) and one green-headed key.

The black-headed keys will lock and unlock the steering column lock/ignition switch, the doors, and the luggage and glove compartments.

The green-headed key is a 'valet' key and must only be used when the vehicle is to be driven and parked by an attendant.

Door locking/unlocking using a black-headed key.

Locking

Note: The security system will not arm if a key is in the ignition switch. The system will arm the vehicle if any protected entry is open but will not monitor that entry until it is closed. Ensure that the keys and the key-ring transmitter are removed from the vehicle before locking the doors, and that all doors, the luggage compartment and the hood are closed.

To lock and set the alarm system

Turn key anti-clockwise and release.

This action locks all doors, the luggage compartment and sets the alarm system.

Hold the key in the 'Lock' position to close all windows and sunroof, if fitted.

Global Locking



WARNING:

When using global locking ensure that all occupants are kept clear of the windows and sunroof aperture (where fitted).

Turn the key anti-clockwise, hold in this position and the vehicle alarm system will arm, the windows (and sunroof, if fitted), will close and the doors and luggage compartment will be locked.

2-6 Security

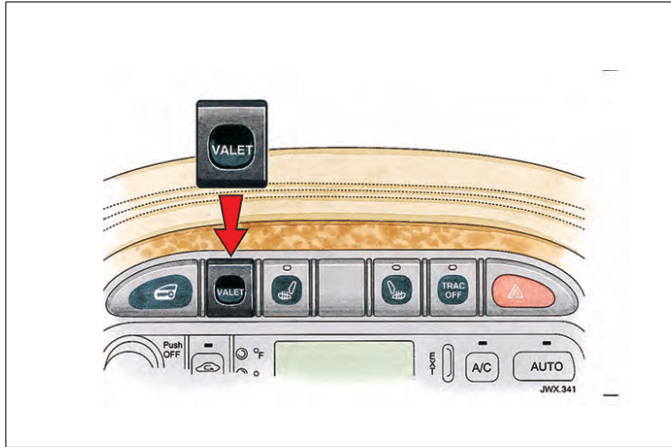

Door Locking System (green-headed 'Valet' key)

Before locking the vehicle and handing the green-headed 'valet' key to a parking attendant, press the valet switch to inhibit the luggage compartment remote release switch. The vehicle can then be parked by an attendant who can lock the vehicle after parking, but cannot open the luggage compartment. The luggage compartment can then only be unlocked with the black-headed key or the key-ring transmitter.

Note: Do not use the green-headed valet key for normal driving. Once isolated from the remote release switch, the luggage compartment cannot be opened with this key.

Unlocking

To unlock and disarm alarm system

Turn key clockwise and release.

This unlocks all doors, luggage compartment, disarms the alarm system, and turns on the interior lights for 2 minutes at $\frac{3}{4}$ brightness. At the same time, the direction indicators will flash twice and two signals will be heard whilst unlocking and disarming takes place.

Hold the key in the 'Unlock' position to open all windows.

Global Unlocking

Put the key into the door lock and hold in the unlock position to disarm the vehicle and open all windows.

Luggage Compartment

The luggage compartment is locked and unlocked electrically in conjunction with the doors. It can also be unlocked by the unlock button on the key-ring transmitter, the remote release switch on the fascia and the black-headed key.

To open the luggage compartment press the badge button in the centre of the lid.

The luggage compartment is illuminated by two lights when the lid is raised.

Unlocking Using the Key-ring Transmitter

To operate: Press the luggage compartment release button.

Unlocking Using the Black-headed Key

To unlock the luggage compartment when the doors are locked: Ensure the security system is disarmed before unlocking using the black-headed key. Insert the key and turn through 90° clockwise, return the key to the vertical position to remove.

Note: The green-headed 'valet' key will not unlock the luggage compartment.

The luggage compartment locks automatically when the lid is closed.

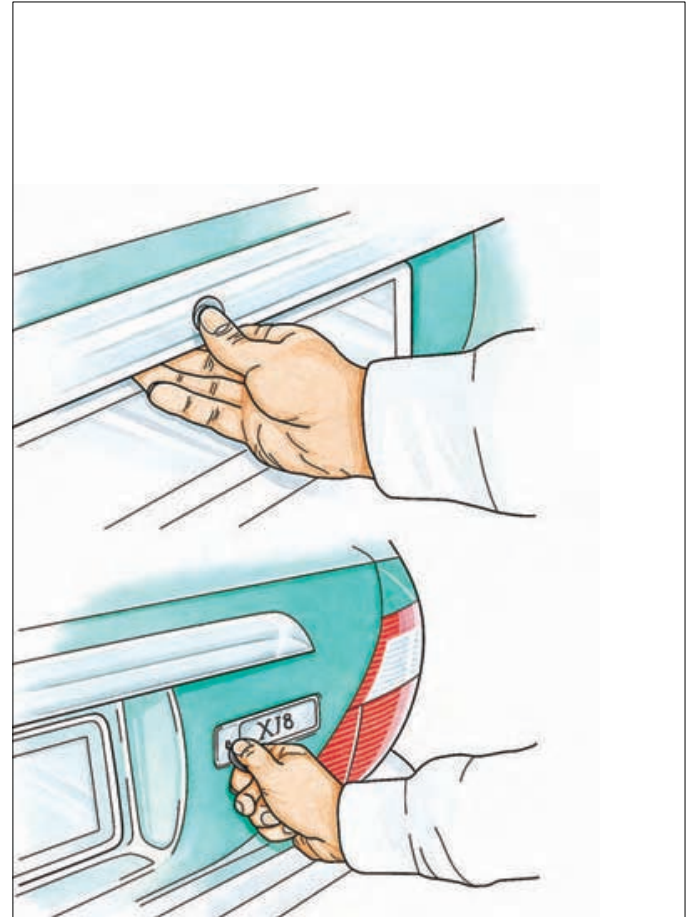

2-8 Security



Luggage Compartment Remote Release Switch

To operate: Press the switch to release the luggage compartment lid lock.

Note: The switch will not operate if the vehicle speed is more than 5 mph (8 km/h).

Central Locking Switch (Console Mounted)

This switch can be used to prevent uninvited entry when the vehicle is stationary, e.g. at road junctions or traffic lights.

With the ignition switch in either position 'I' or 'II' and all doors, luggage compartment and hood closed, one press of the switch will lock all the doors and the luggage compartment.

Press and hold the switch for 3 seconds to close all the windows and sunroof (where fitted).

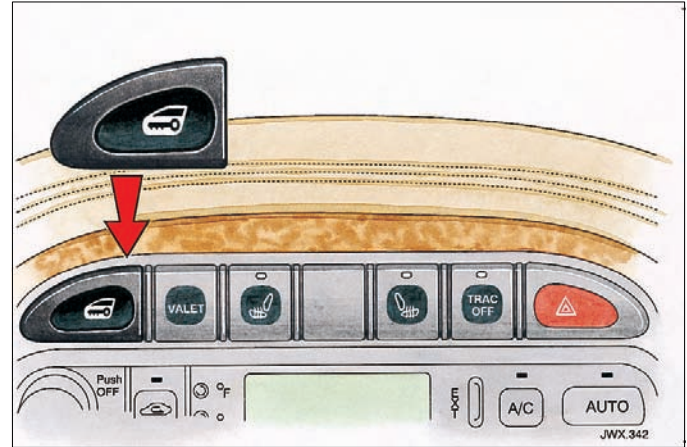

WARNING:

Ensure that all occupants are clear of any open windows and sunroof aperture (where fitted).

If all doors are locked and the ignition switch is in position 'I' or 'II', pressing the central locking switch will unlock all doors.

If the central locking switch is pressed when the ignition switch is not in position 'I' or 'II', the security system's tilt and intrusion sensors, if fitted, will not operate for one arming period. The security light in the gear selector lever surround will flash to indicate that this has occurred. Flashing will continue for 10 seconds or until the vehicle is armed.

After using the central locking switch, it will be necessary to press the switch again or pull the front door interior release lever to resume normal operation.

Interior Door Lock Operation

To lock: Press down the front door locking buttons to lock all doors and luggage compartment.

To unlock: Pull the door release lever.

The rear doors can be locked independently by pressing down the rear door locking buttons and unlocked by operating the door release levers.

With the doors locked, operation of the release levers on either front door first unlocks the door and all other doors via the Central Locking System, then unlatches that door.

Each rear door will unlock and then unlatch individually by operation of the door release levers.

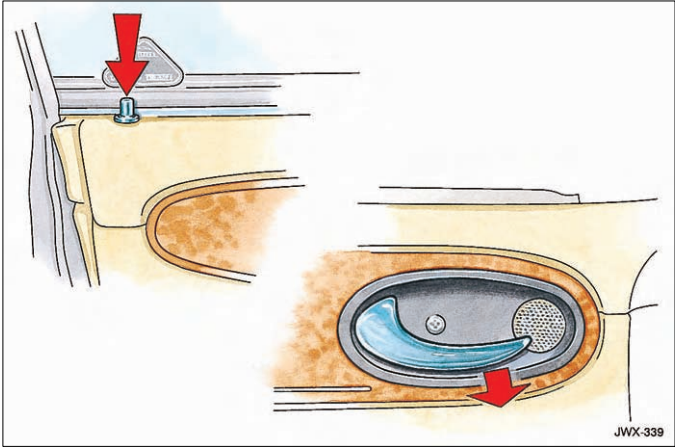

Child Safety Locks

Child safety locks are fitted to the rear doors.

To operate: Open the door and move the lever up. This immobilises the interior handle. The door can only be opened using the exterior door handle.

To cancel: Open the door and move the lever down.

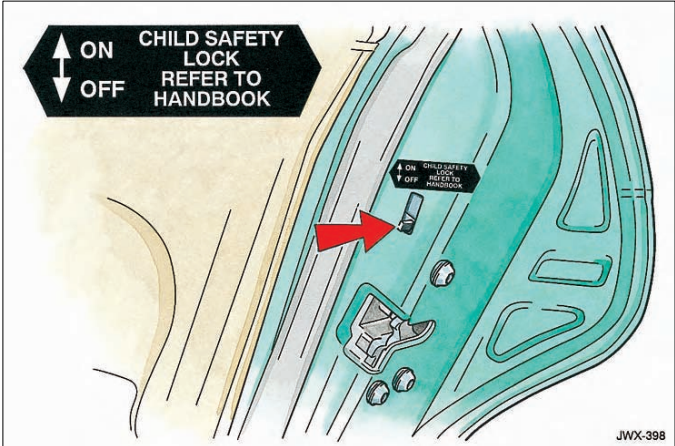

2-10 Security

Alarms and Audible Signals

Full Alarm

Once armed, any of the following circumstances will create a full alarm state:

- Opening a door.
- Opening the luggage compartment with the key (a ticking sound will be heard and the full alarm is delayed for seven seconds).
- If an invalid key is inserted into the ignition switch and turned to position 'I' or 'II'.
- Lifting or tilting the vehicle, for example, an unauthorised towing away attempt (if a tilt sensor is fitted).
- Pressing headlamp button on key-ring transmitter three times within 3 seconds produces the Panic Alarm (if fitted).

Error Tone

The sounder gives a short, high-pitched tone whenever one of the following conditions is present:

- If any door is open when an attempt to 'arm' the security system is made.
- The luggage compartment is not properly closed when an attempt to 'arm' the security system is made.
- If a key is in the ignition switch when a transmitter button is pressed.
- If there is an electrical failure within the tilt sensing system, (if fitted), and an attempt to 'disarm' the security system is made.

Audible Signals

An audible signal will sound when:

- The 'Valet' switch is pressed with the luggage compartment closed or when in Valet mode and the interior luggage compartment release button is pressed.

Security System Features

Drive-away Door Locking

This feature is an additional occupant safeguard which locks all the doors and luggage compartment if they are unlocked when the gear selector is moved out of the 'P' or 'N' position. For this feature to operate, the ignition switch must be in position 'II', and all doors and the luggage compartment lid closed.

Panic Alarm (Dealer option)

When in or near the vehicle, the alarm can be set off to deter a would-be offender. This feature will also unlock the doors. For this feature to operate, the key must **not** be in the ignition switch.

Pressing the headlamp button on the key-ring transmitter three times within 3 seconds will activate the 'Panic Alarm'.

The Panic Alarm will sound for the normal full alarm period. The alarm is stopped by turning the ignition key to position 'I' or 'II'.

The key-ring transmitter cannot be used to cancel the Panic Alarm, this prevents unauthorised use.

Fuel Filler Flap

The fuel filler flap is locked and unlocked in conjunction with locking or unlocking the vehicle only when using a key or a key-ring transmitter.

Remote Headlamp Convenience

By pressing the key-ring transmitter button with the dipped headlamp symbol, the headlamps will come on for 25 seconds, unless the headlamp button is pressed again, or if the key is inserted in the ignition switch and turned to position 'II'.

Passive Arming (Dealer option)

Note: Passive arming will not lock the doors, it only arms the security alarm system.

Passive arming, if preset by a Jaguar Dealer, will automatically arm the vehicle alarm system 30 seconds after the last protected entry, (door, luggage compartment or hood) is closed following the key being removed from the ignition switch.

When passive arming occurs the direction indicators will flash once and a single tone will be heard. The red security light on the gear selector surround will start to flash and will continue for as long as the vehicle is armed.

Opening a protected entry causes a warning sound which continues for 15 seconds before the vehicle goes into the full alarm state.

If the system has been armed passively it can be disarmed by either the key-ring transmitter, by switching the ignition to position 'I' or by unlocking the driver's door with a key.

Note: The security system will not passively arm if a key is in the ignition switch or if any protected entry is open.

2-12 Security

Perimeter Sensing

Perimeter sensing is put into operation every time the vehicle is armed. This feature sounds the alarm if any unauthorised opening of doors or luggage compartment or hood occurs.

Battery Tampering Alarm and Restart Procedure

This feature prevents the security system being by-passed by battery disconnection.

If the battery is disconnected when the security system is either armed, disarmed or in the full alarm state, the security system will automatically resume the vehicle state before disconnection when the battery is reconnected.

Tilt Sensing Protection (if fitted)

This feature protects against unauthorised towing away or jacking up. As soon as an attempt is made to tilt the vehicle, to tow away or jack the vehicle up, if the system is 'armed', the security system will enter the full alarm state.

To switch off the tilt sensing protection feature, turn the ignition key to the '0' position then press the central locking switch. The security light in the gear selector lever surround will flash to confirm that the tilt sensing is off.

This procedure may be necessary when the vehicle is being transported by road, rail or sea.

The tilt sensing will return to normal when the security system is disarmed and subsequently armed.

Intrusion Sensing (if fitted)

Every time the vehicle is armed and deadlocked, the alarm will sound if intrusion into the passenger area occurs.

Battery Back-up Sounder

On certain markets a separate battery back-up sounder is fitted. This device will sound an alarm if the vehicle battery or the sounder is disconnected when the security system is armed.

Caution: Do not disconnect the vehicle battery or sounder if the security system is armed as this will cause the alarm to sound. To switch off the alarm – reconnect the vehicle battery or sounder and disarm the security system in the usual manner.

Engine Immobilisation

The ignition key has an engine immobilising device in the plastic head. Engine immobilisation occurs automatically when the ignition key is turned to position '0'.

Caution: Should the ignition key be lost, a new key can be obtained and programmed to the vehicle by a Jaguar Dealer who will ask for proof of vehicle ownership. It is advisable to notify a Dealer as soon as a key is lost or stolen and have the remaining key(s) reprogrammed. This will then prevent the lost or stolen key from being used to start the engine.

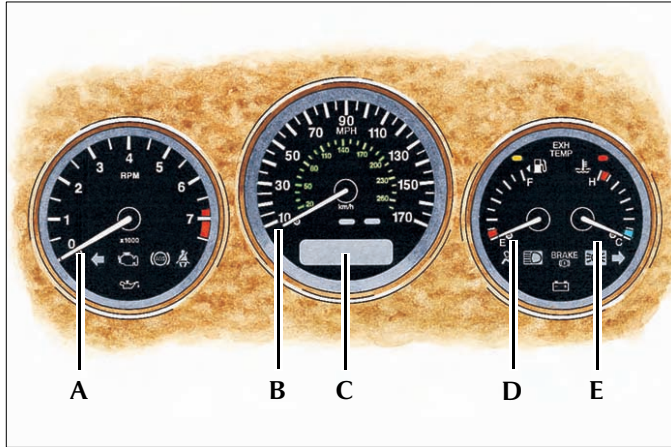

Instruments

Tachometer (A)

The tachometer indicates engine speed in revolutions per minute and is calibrated in increments of 500 extending to 7500 rev/min.

Speedometer (B)

USA: Speed indication is in miles per hour with kilometres per hour on an inner ring.

Canada and Mexico: Speed indication is in kilometres per hour with miles per hour on an inner ring.

Odometer (C)

Records the total distance covered by the vehicle.

Fuel Level Gauge (D)

Indicates the amount of fuel in the tank. The gauge works only with the ignition ON and in position 'II'.

A warning light indicates when the remaining fuel has fallen to approximately 2.6 US gallons (10 litres).

Engine Coolant Temperature (E)

Indicates the temperature of the engine coolant.

Drive at moderate road and engine speeds until normal operating temperature is reached. This is indicated when the pointer is between the blue (cold) segment and the red (hot) segment.

The engine operating temperature will vary with changes in weather and engine load. The engine temperature may rise in some circumstances, such as:

- Idling for long periods in slow moving traffic.
- Driving up a long hill in hot weather.
- Driving slowly or stopping after driving at high speed.

Should the pointer move into the red segment (H), stop the vehicle as soon as it is safely possible and allow the engine to cool.

Switching off the climate control system may assist engine cooling.



WARNING:

Do not remove the pressure cap from the coolant expansion tank filler while the engine is hot.

3-2 Instruments - controls



Warning Lights

Thirteen warning lights are arranged within the dials of the instrument cluster.

RED warning lights are for primary warnings. AMBER warning lights are for secondary warnings. Lighting and direction indicator warning lights are BLUE or GREEN.



A bulb check cycle is initiated when the ignition is switched ON and lasts for 3 to 4 seconds. The CHECK ENG warning light stays on until the engine is started. If any warning light remains on, investigate the cause before driving.

When activated, some warning lights have associated messages displayed on the message centre, as shown in the following table.





Instruments - controls 3-3

Warning Lights	Message	Priority Indicator	Meaning
 <p>Check Engine</p>	None	None	<p>Lights up when the ignition is switched ON and remains on until the engine is started.</p> <p>Note: Lights up if an engine management event is detected. Specialized diagnostic equipment is required to repair such faults. Report the fault to Jaguar Dealer. The engine management system has a 'limp home' capability. Possible reduced performance means that the vehicle may be driven but only with caution.</p>
	<p>RESTRICTED PERFORMANCE OR FAILSAFE ENGINE MODE</p>	Amber	Loss of power and driveability. Report the fault to a Jaguar Dealer. The vehicle may still be driven.
		Red	Loss of power and driveability. Report the fault to a Jaguar Dealer. Do not drive the vehicle.
	TRANSMISSION FAULT	Amber	Transmission defaults to a 'limp home' mode, giving reduced operation. Drive with caution. Report the fault to a Jaguar Dealer immediately.
	TRANSMISSION HIGH TEMP	Amber	Transmission defaults to 'hot mode' to aid cooling. The vehicle may still be driven.



3-4 Instruments - controls

Warning Lights	Message	Priority Indicator	Meaning
 <p data-bbox="98 325 261 381">Anti-lock Braking (ABS)</p>	None	None	<p data-bbox="689 239 1461 292">Lights up if a fault has been detected in the ABS system. The brake system will continue to function normally but without ABS braking.</p> <p data-bbox="689 303 1445 356">Should the light come on or stay on after the bulb check cycle, stop the vehicle at the first opportunity, turn the engine OFF and then restart.</p> <p data-bbox="689 367 1318 420">If the warning light comes on again, consult a Jaguar Dealer immediately.</p> <p data-bbox="689 431 1442 483">The vehicle may be driven to a Jaguar Dealer if the ABS warning light is ON, but must not be driven if the brake warning light is ON</p>
 <p data-bbox="130 594 233 617">Seat Belt</p>	None	None	<p data-bbox="689 508 1433 561">Lights up for six seconds when the ignition is ON and the driver's seat belt is not fastened. An audible warning sounds for six seconds.</p> <p data-bbox="689 572 1461 680">Note: Ensure seat belts are fastened before driving. If the warning light stays ON with the seat belt fastened, report the fault to a Jaguar Dealer. It is safe to drive the vehicle with the light ON, provided that the seat belts are properly fastened.</p>
 <p data-bbox="140 792 226 815">Airbag</p>	None	None	<p data-bbox="689 706 1401 759">When the ignition switch is turned to position 'II', the warning light comes ON for five seconds.</p> <p data-bbox="689 770 1458 823">If the airbag system develops a fault, the warning light will come ON and remain on until the fault has been diagnosed and cleared.</p> <p data-bbox="689 834 1417 887">Report the fault to a Jaguar Dealer immediately. It is safe to drive the vehicle; however, in an accident the airbags may not operate.</p>



Instruments - controls 3-5

Warning Lights	Message	Priority Indicator	Meaning
 <p>Headlamp Main Beam</p>	None	None	Lights up when the headlamps are on main beam.
 <p>Brake (USA)</p>  <p>Brake (Canada and Mexico)</p>	LOW BRAKE FLUID	Red	<p>Lights up when the ignition is ON if the handbrake is applied and/or the brake fluid is low.</p> <p>If the light is ON with the handbrake NOT applied, low brake fluid is indicated. In this case, loss of braking assistance in either or both brake circuits may be imminent.</p> <p> WARNING: DO NOT drive the vehicle until the fault is rectified. Consult a Jaguar Dealer immediately.</p>
 <p>Sidelights</p>	None	None	Lights up when the sidelights are switched ON.

3-6 Instruments - controls

Warning Lights	Message	Priority Indicator	Meaning
 <p>Direction Indicator Tell-tale (left and right)</p>	None	None	<p>The appropriate indicator tell-tale will flash when the column switch is moved up or down to signal a right or left-hand turn.</p> <p>If a direction indicator fails, the tell-tale will flash and the audible warning will sound at twice normal rate when that indicator is selected. Fit a new bulb immediately. See Bulb Renewal in SECTION 5 of the Vehicle Care Handbook.</p> <p>Hazard Warning Indicators</p> <p>When the hazard warning switch is selected, both direction indicator tell-tales will flash, simultaneously with all direction indicators, and repeaters (where fitted).</p>
 <p>Low Fuel Level</p>	None	None	<p>Lights up to indicate low fuel level. This warning light is additional to the fuel level gauge and will come ON when the fuel has fallen to approximately 2.6 US gallons (10 litres).</p>
 <p>Low Oil Pressure</p>	LOW OIL PRESSURE	Red	<p>Lights up when the ignition switch is in position 'II' and should go out when the engine is running. If the light is ON when the engine is running, loss of oil pressure is indicated. Stop the engine immediately and investigate the cause. Do not restart until the fault has been rectified.</p> <p>First check the engine oil level. See Checking and Replenishment in SECTION 3 of the Vehicle Care Handbook.</p>

Instruments - controls 3-7

Warning Lights	Message	Priority Indicator	Meaning
 <p>Ignition (Charge Warning)</p>	<p>BATTERY NOT CHARGING</p>	<p>Red</p>	<p>Lights up when the ignition switch is in position 'II' and should go out when the engine is running. If the light stays ON when the engine is running it indicates either high or low battery voltage or that the generator is faulty.</p> <p>Stop the engine and investigate the cause.</p>
 <p>High Coolant Temperature</p>	<p>None</p>	<p>None</p>	<p>Lights up if the engine coolant temperature becomes too high (gauge pointer in the red segment). It is unsafe to run the engine with the coolant temperature overheated.</p> <p>If the light comes ON, stop the vehicle and switch the engine OFF. Allow the engine to cool. Report the fault to a Jaguar Dealer.</p> <p> WARNING: Do not attempt to remove the pressure cap from the coolant expansion tank until the engine is cool.</p>

3-8 Instruments - controls

Message Centre

Driver information, messages, and data are displayed on the message centre display situated within the speedometer.

The message centre has three functions. These are:

1. **Odometer:** Displays the total distance covered by the vehicle.
2. **Trip Computer:** Displays information on the vehicle's average speed, fuel usage and range.
3. **Warning and Information Messages:** Displays status messages or warning messages if system faults are detected.

Selecting Message Centre Functions

Message centre functions are selected by repeatedly pressing the trip function button on the left-hand column switch. The first press will switch from the odometer reading to the trip computer. Further presses will cycle through the trip computer data in sequence, until the odometer reading is displayed again.

Note: Messages take priority over the odometer reading or trip computer data and, if active, will be displayed when the ignition is switched ON.

Odometer

When the ignition is switched ON the message centre displays the odometer reading. The odometer will also be displayed if the ignition switch is in position '0' and the interior lights are ON.

USA: The odometer reading is displayed in miles.

Canada and Mexico: The odometer reading is displayed in kilometres.

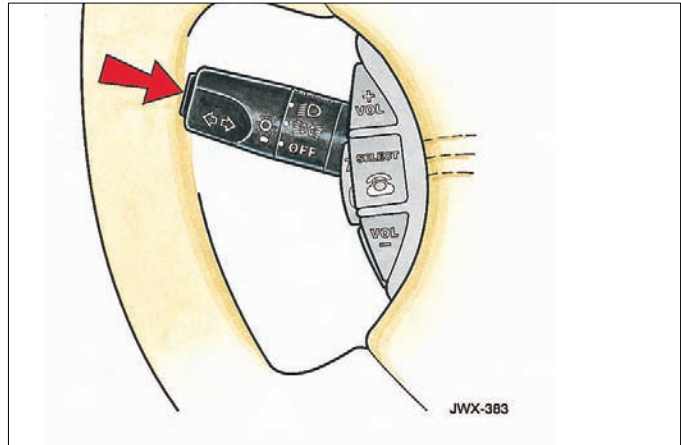
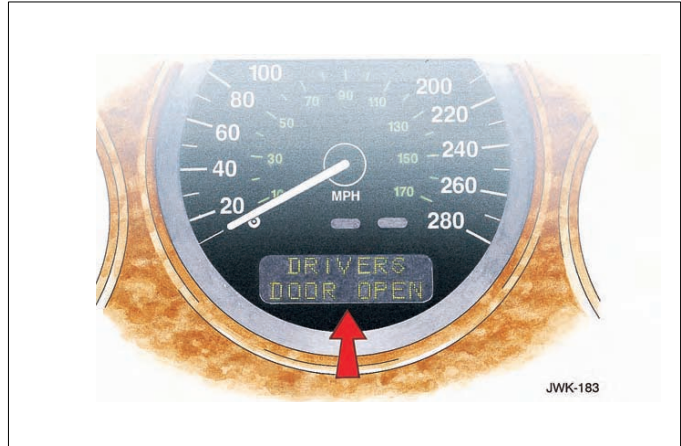

Warning and Information Messages

The message centre will display warning or information messages to the driver when the ignition switch is in position 'II'.

Most messages, when displayed, have an associated priority indicator light above the display which will come on to indicate the message priority:

Red light: Priority message

Amber light: Secondary message.



WARNING:

If a red warning light is displayed, stop the vehicle, or take appropriate action, as soon as possible.

A priority message must be investigated immediately by the driver or a Jaguar Dealer.

If more than one message is active, each is displayed in turn for 2 seconds in order of priority.

Clearing Messages

Messages can be hidden by pressing CLEAR on the trip computer switchpack. One press will hide one message. Once all messages have been hidden, the display will show trip data, a further press will display the odometer reading. If CLEAR is pressed again all active messages will be 're-displayed'. Repeatedly pressing the CLEAR button will cycle through the trip odometer and message modes.

Hidden messages reappear after the ignition is switched OFF and ON again, if the fault remains.

If a fault occurs when in trip computer or odometer mode, the relevant message will be displayed immediately.

If a trip computer function is selected by pressing the function button while messages are displayed, the trip data will be displayed for 10 seconds, then the message will reappear.

Language Selection

To obtain the language selection feature, press and hold the 'm/k' switch on the trip computer switchpack whilst turning the ignition key to position 'II'. The first language displayed is the one currently selected. The language will be displayed for 10 seconds.

To cycle through the language options, press the 'm/k' switch repeatedly while the languages are still being displayed.

When the language required is displayed press the 'A/B' switch. The new language will be selected and displayed for a further 2 seconds.

Press CLEAR or start the engine to display the odometer reading. (The odometer reading is automatically displayed after 10 seconds.)

Message Centre Illumination

The message centre is illuminated at all times when the ignition is ON.

The illumination level can be adjusted by the dimmer switch (see page 3-14).

3-10 Instruments - controls

Message	Priority Indicator	Meaning
SYSTEM CHECK	Both	Instruments self check immediately after ignition ON and language selection.
ENGINE STALLED	Red	Engine speed has dropped below 10 rev/min.
ENGINE COOLANT LOW	Red	Check the level in the coolant reservoir. Check temperature gauge often.
DRIVERS DOOR OPEN	Red	Check that the driver's door is closed before driving.
PASSENGERS DOOR OPEN	Red	Check that the passenger's doors are closed before driving.
TRACTION CONTROL FAIL	Amber	Report fault to a Jaguar Dealer. The vehicle may still be driven.
ASC	Amber	Traction Control is operating.
FAIL SAFE ENGINE MODE OR RESTRICTED PERFORMANCE	Amber	Loss of power or driveability. Report the fault to a Jaguar Dealer. The vehicle may still be driven.
	Red	Loss of power or driveability. Do not drive the vehicle. Report the fault to a Jaguar Dealer.
HOOD OPEN	Red	Check that the hood is closed securely.
TRUNK OPEN	Red	Check that the luggage compartment is closed securely.

Instruments - controls 3-11

Message	Priority Indicator	Meaning
GEARBOX FAULT	Amber	Transmission defaults to a limp home mode giving reduced operation. Drive with caution. Report fault to a Jaguar Dealer immediately.
PARK BRAKE ON	Red	Check that the handbrake is fully OFF.
CHECK REAR LIGHTS	Amber	Rear bulb failure.
WASHER FLUID LOW	Amber	Check the fluid in the windscreen washer reservoir.
VALET MODE	None	Displayed for 3 seconds when the valet mode is activated and if interior luggage compartment release is pressed in valet mode.
ELECTRICAL FAULT	Amber	Ignition supply fault. Possible reduced electrical operation. Most warning lights will not operate. Report the fault to a Jaguar Dealer immediately.

3-12 Instruments - controls

Trip Computer

The computer memory stores data for a journey or series of journeys until it is reset to zero. Two independent memories are available (A and B) to allow two separate journeys to be recorded concurrently, e.g. work usage and evening/weekend usage.

All trip data displayed, apart from 'Range' and 'Instantaneous Fuel Usage' will be prefixed by the letter A or B depending on which trip memory was last selected.

The information is for guidance only, as it can be affected by traffic, road and weather conditions.

To display trip data on the message centre the ignition must be in position 'II'. Press the function button repeatedly to display the data in the following order:

Odometer

Total vehicle distance travelled.

Trip Distance

Distance travelled since the last memory reset. The maximum trip reading is 9999.9 miles (16090 kilometres). The computer will automatically reset to zero if this distance is exceeded.

Range

Distance that the vehicle should travel on the remaining fuel, assuming average speed and fuel consumption stay constant.

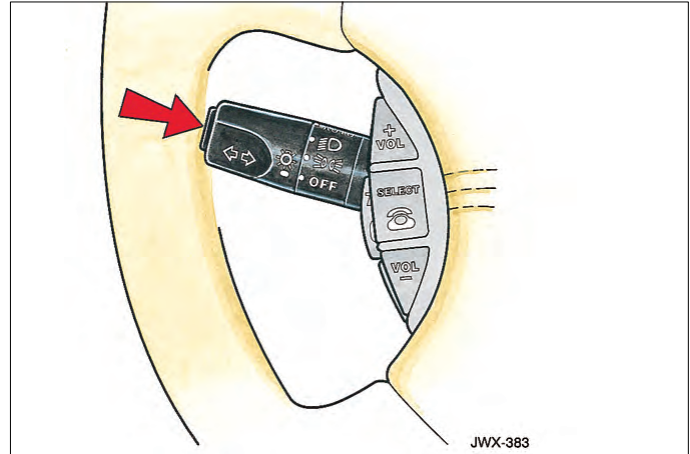

Fuel Used

The amount of fuel used since the last memory reset.

Average Fuel

The display shows 'AVE FUEL'. Average fuel consumption since the last memory reset.

Instantaneous Fuel Usage

The display shows 'INST FUEL USAGE'. The 'at the moment' fuel consumption, calculated over a 3 second period and continuously updated.

Average Speed

For the distance travelled since the last memory reset.

Trip Computer (continued)

The Trip Computer Switchpack

000

Sets the selected trip to zero.

A/B

Toggles between trip memories A and B, while memory data is being displayed.

m/k

Selects metric or imperial data display.

CLEAR

The CLEAR button can be used to cycle through: TRIP – ODO – MESSAGES.

Note: The 'A/B' and 'm/k' buttons are also used for the message centre language selection feature.

Trip Data Display

Warning and Information messages have priority over trip data and, if active, will be displayed when the ignition is ON.

To hide warning messages and display trip data, press the CLEAR button.

Note: If messages are not hidden, trip data can still be selected by using the function button. Trip data will be displayed for 10 seconds before the message is displayed again.



Resetting the Trip Computer

At the start of the journey, or series of journeys, to be recorded, reset the computer memory to zero as follows:

1. Press the trip function button to select a computer function. The computer will display either trip A or trip B data.
2. Press the A/B switch to select the trip (A or B) to be reset.
3. Press the 000 switch and hold for 3 seconds.
The display will read: **A: TRIP RESET**
or **B: TRIP RESET**
Then it will reset and display: **A: 0.0**
or **B: 0.0**

Note: Only the trip displayed (A or B) will be reset.

Continued

3-14 Instruments - controls

Trip Computer (continued)

Selecting Metric/Imperial Display

Pressing the 'm/k' switch displays data in metric or imperial units alternately. The units used for computer functions are:

FUEL USED – US Gallons (USA) and Litres (Canada and Mexico)

AVERAGE FUEL – Miles per US gallon (USA) and litres per 100 km (Canada and Mexico)

INSTANTANEOUS FUEL – Miles per US gallon (USA) and litres per 100 km (Canada and Mexico)

Notes On Using The Trip Computer:

1. 'Range' and 'Instantaneous Fuel Usage' data is independent from the trip computer and cannot be reset. The data is common to both trip memories and is not prefixed by A or B on the display.
2. The trip memory cannot be reset to zero if either 'Range' or 'Instantaneous Fuel Usage' is displayed.

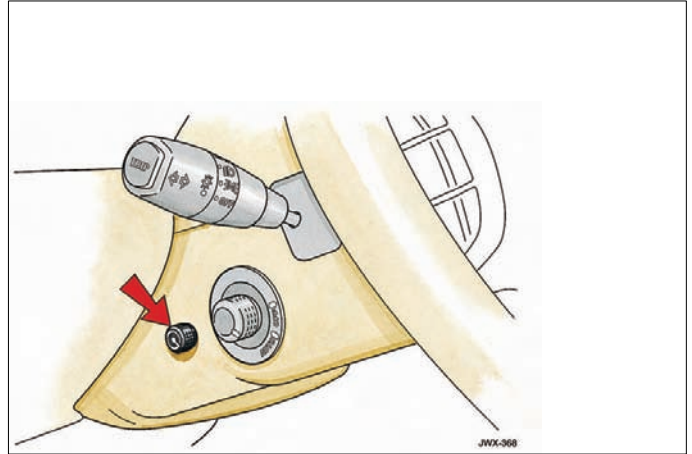

Instrument Illumination and Dimmer Switch

With the ignition switch in position 'II', the instruments, message centre, climate control and sound system displays will be illuminated. When the exterior lighting is switched ON, the instruments and message centre may be dimmed by means of the dimmer switch. The climate control panel and radio will be illuminated at a low level. If the dimmer switch is set to the 'override' position, the instruments, message centre, climate control and sound system displays, will be illuminated at maximum brightness. Warning light brightness is not affected by the dimmer switch.

To operate: Rotate the knob to adjust the illumination to the required level. To select 'override', turn the knob fully anti-clockwise.

Clock

The analogue clock can be adjusted by pressing the (+) and (-) buttons below the dial. Pressing and holding either button will increase the rate of hand movement forwards or backwards as required.

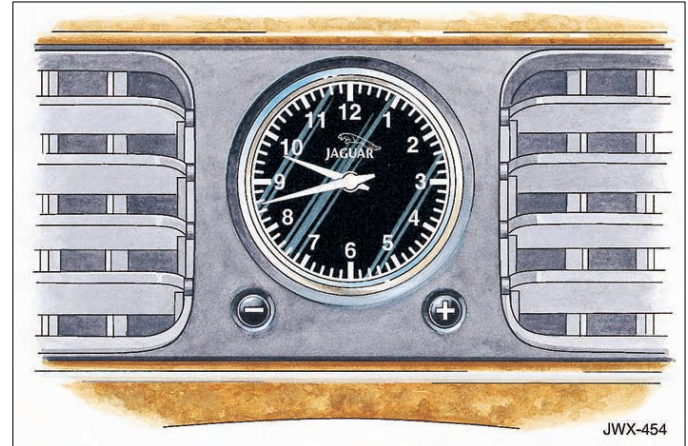

Park Brake (Handbrake)

The park brake (handbrake) lever is mounted on the inboard side of the driver's seat and mechanically operates the rear parking brakes. The parking brakes are independent of the main brake system.

To apply: Lift the lever firmly. The park brake should be fully ON after three or four clicks. The **Park Brake On** warnings will be activated (see below).

To release: Lift the lever slightly, press the locking button at the end of the lever, and lower to the OFF position. If the handbrake lever is not fully OFF, the **Park Brake On** warnings will stay on (see below).

Handbrake On Warnings

The park brake warning/brake fluid low warning light will illuminate and a text message will be displayed.

Message: **Park Brake On**

Priority Indicator: **Red**

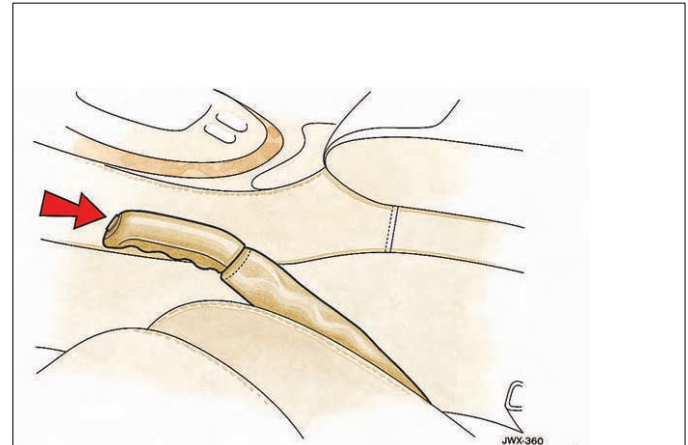

3-16 Instruments - controls

Automatic Transmission

The five-speed automatic transmission is designed to accommodate different driving styles and automatically adapt shift patterns to suit varying road/driving conditions.

The switch marked 'S' on the 'J' gate surround enables the driver to select either normal 'N' or sport 'S' transmission modes.

In addition to the 'switched' transmission modes ('N' and 'S') the transmission control module will select shift patterns to suit specific conditions. These are:

Cruise Control – When cruise control is operating at set speed the transmission selects a shift pattern to suit cruise control operation.

Traction Control – When traction control is switched ON and the system is activated, the transmission selects a shift pattern to suit traction control conditions.

Gradients – When the vehicle is being driven on roads with uphill gradients, the transmission selects a shift pattern designed to make better use of engine power and aid engine cooling.

Note: Under the conditions described above, the relevant transmission mode will override the 'N' or 'S' modes selected by the driver. When such conditions no longer exist, e.g. Cruise Control switched OFF, the transmission will revert to the shift pattern previously selected by the driver, i.e. 'N' or 'S'.

'J' Gate Selector

The 'J' gate gear selector lever is designed to accommodate two different driving techniques as follows:

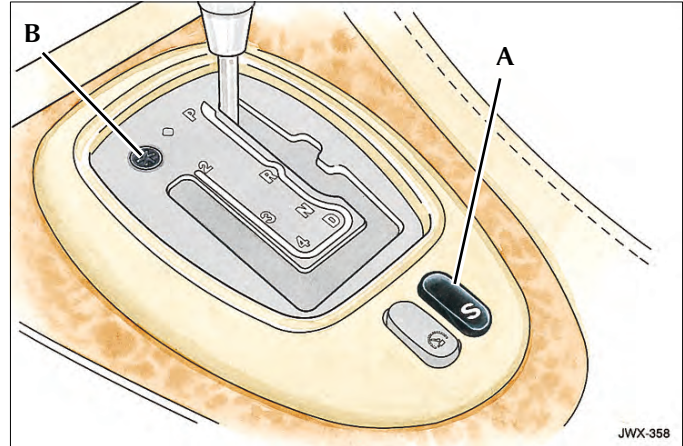

1. **Automatic selection** – the right-hand side of the selector gate is less cluttered than a conventional selector.
2. **Manual selection** - the left-hand side of the J-gate.

Note: Both sides of the 'J' gate can be used irrespective of the transmission mode, e.g. with 'S' selected the transmission can be operated in full automatic or by manual selection.

Sport Mode

Switch (A) selects either normal 'N' or sport 'S' mode.

When sport mode is selected the gear shift points are extended to make full use of the engine's power reserves.

To operate: Press the switch (A). The switch lights up to indicate that sport mode has been selected. Press the switch again to cancel sport mode.

Gear-shift Interlock

A brake pedal/gear-shift interlock system is incorporated in the gear selector mechanism. Once the ignition key has been removed the gear selector is locked in position 'P'. Also the ignition key cannot be removed from the ignition until the gear selector has been moved to position 'P'.

To move the gear selector from position 'P':

1. Turn the ignition key to position 'II' or start the engine.
2. Press the brake pedal.

To remove the ignition key move the gear selector to Park 'P'.

Gear-shift Interlock Manual Override

In the event of the gear-shift interlock failing to operate, the gear selector can be unlocked from the 'P' position manually as follows:

1. Remove the screw-in plug (B) (see illustration on previous page) using a suitable tool.
2. Insert the ignition key (or similar shaped tool) into the hole.
3. Push the key/tool down gently and hold whilst simultaneously moving the gear selector out of 'P', but not into Reverse.

Caution: Do not move the gear selector fully into reverse until the ignition key/tool has been removed from the 'J' gate.

4. An audible warning will sound when the gear selector is moved from 'P' provided the ignition is OFF.
5. Remove the ignition key/tool and move the gear selector into neutral for starting. Refit the plug.

Gear Selector Positions



WARNING:

The handbrake or brake pedal must be applied before selecting forward or reverse drive from a stationary position.

Note:

1. After selecting forward or reverse drive ranges from Neutral or Park, wait briefly for the transmission to engage before accelerating.
2. When in Neutral or Park the engine can only be accelerated to 3000 rev/min (supercharged models only).

P Park – Only use when parking. Apply the park brake before selecting park.

R Reverse – Do not select if the vehicle is moving forward. The reversing lights come ON automatically with 'R' selected and the ignition switch in position 'II'.

N Neutral – Disconnects the driveline from the engine. Use with handbrake when stopping temporarily.

D Drive – All five gears are changed automatically as required by the throttle position and road speed.

- 2, 3, 4** Second, third, fourth – If selected, the transmission operates automatically but will not engage gears higher than the one selected.

Continued

3-18 Instruments - controls

Automatic Transmission (continued)

Drive To Fourth

When driving in gear position 'D' with fifth gear engaged, the gear selector can be shifted horizontally across the gate to '4'. Provided that the vehicle's speed is not too great, the transmission will shift down to fourth.

Fifth will be inhibited until the gear selector is moved back to 'D'.

Starting and Stopping

The engine cannot be started until the gear selector is in 'N' or 'P'.

When the vehicle is stationary the gear selector may be left in 'D', '2', '3' or '4', unless the vehicle is to be parked. When stopping for traffic lights, junctions etc., apply the handbrake and select 'N'.

Note: When the ignition switch is in position '0', an audible warning will sound for 10 seconds if the gear selector is not in 'P'.

Engine Braking on Downhill Gradients

To achieve appropriate levels of engine braking when driving on roads with long downhill gradients, position '3' or '2' may be selected depending on road and traffic conditions.

When the gear selector is moved from 'D', '4' or '3' down to '2', downshift to second gear will only take place at road speeds below 60 mph (96 km/h).

Shift Inhibit

Upshifts will be inhibited when cornering at high speeds. Selecting reverse is inhibited when the vehicle is moving forward.

Note: Reverse inhibit will not function in limp home mode.

Kickdown

Kickdown is operated when the accelerator pedal is pressed fully down. Kickdown is used to change to a lower gear in circumstances where rapid acceleration is required, such as when overtaking.

Kickdown causes the transmission to change down to the lowest gear possible to achieve maximum acceleration. The gear engaged depends on the road speed at the time of kickdown. Kickdown provides maximum engine performance.

As well as shifting down, the gear shift points are extended to give greater performance. This mode is in effect for as long as the pedal is pressed fully down.

Automatic Transmission (continued)

Limp Home Mode

In the unlikely event of an electrical or mechanical transmission fault, the transmission will enter limp home mode, which enables the vehicle to be driven to a safe area. Vehicles with normally aspirated engines will default to 4th or 5th gear. Vehicles with supercharged engines will hold the gear engaged at the time of the fault.

After stopping and placing the gear selector in 'P', for supercharged engines, only second gear and reverse can be selected. For all vehicles, reverse gear can also be selected.

The driver should be aware that in limp home mode the vehicle's performance will be greatly reduced and must take this into account when driving. In this event consult a Jaguar Dealer **immediately**.

Message: **Transmission Fault** Priority Indicator: **Amber**

Note: For details of vehicle recovery, see **Vehicle Recovery** in SECTION 4 of the Vehicle Care Handbook.

3-20 Instruments - controls

Traction Control

The traction control system will intervene to prevent wheel spin if it is detected by wheel speed sensors. Under these conditions, engine torque is controlled within driver demand and individual wheel braking is applied.

This also improves acceleration, particularly on surfaces with uneven friction, e.g. one wheel on ice, the other on tarmac.

Traction Control is always switched ON when the engine is started. The system can be switched OFF by pressing the TRAC OFF switch on the centre console switchpack. The LED in the switch lights up to warn that the system has been switched OFF. If the switch is pressed again the system will switch ON.

Note: If cruise control is engaged it will automatically disengage if Traction Control activates.

If the system is activated a message is displayed and the amber warning light flashes.

A system malfunction is indicated by a message. It is safe to drive the vehicle but the system may not activate under wheel spin conditions. Report the fault to a Jaguar Dealer as soon as possible.

Message: **Traction Control Fail** Priority Indicator: **Amber**

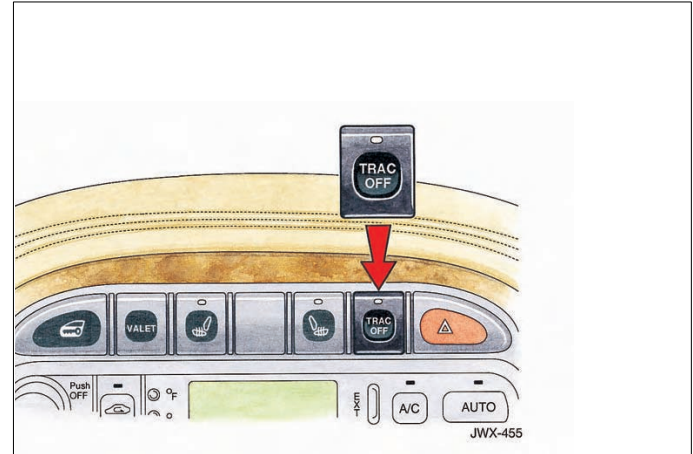

WARNING:

- 1. The fact that the vehicle is fitted with Traction Control must never allow the driver to be tempted into taking risks which could affect his/her safety or that of other road users. In all cases it remains the driver's responsibility to drive safely according to the prevailing conditions.**
- 2. Traction Control systems cannot overcome the consequences of trying to corner at too high a speed.**
- 3. It is recommended that, if using snow chains, Traction Control should be switched OFF.**

Cruise (Speed) Control (where fitted)

The cruise (speed) control, when activated, maintains a constant road speed without the driver having to use the accelerator.

The system is operated by an ON/OFF master switch (A) mounted in the gear selector surround and four control buttons mounted on the steering wheel. These are:

‘SET +’: Set speed or accelerate (B)

‘-’: Decelerate (C)

‘RESUME’: Resume set speed (D)

‘CANCEL’: Cancels without erasing memorised speed (E).

Note: The cruise control mode will not operate below speeds of 16 mph (26 km/h).

Setting a Speed



WARNING:

Only use cruise control when conditions are favourable, e.g. straight, dry, open roads with light traffic.

Push the ON/OFF switch. A red warning light on the switch will indicate that the system is ON.

Accelerate as normal until the required speed is reached.

Press the ‘SET +’ button briefly and the vehicle speed will then be stored in the memory and the system engaged.

The driver can then release the accelerator and the set road speed will be maintained.

Note: Braking will cancel the cruise control function, restoring accelerator control to the driver.

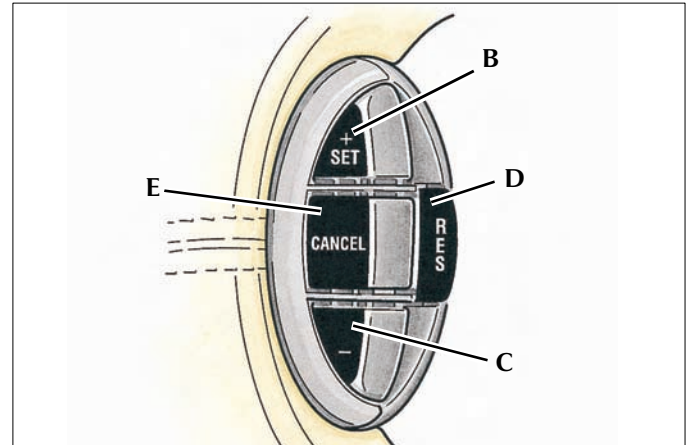
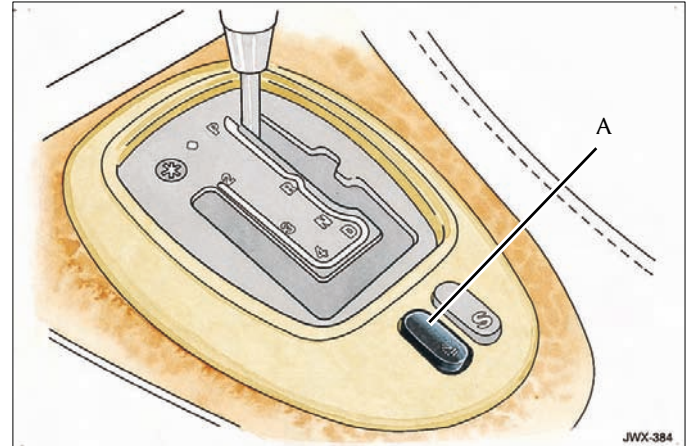

3-22 Instruments - controls

Changing the Set Speed

There are three ways to change the set speed.

1. Accelerate or brake to the required speed and press the 'SET +' button.
2. Increase or decrease the speed by pressing and holding either the 'SET +' or '-' button. The speed will change gradually until the button is released.
3. Increase or decrease the speed in steps of 1 mph (2 km/h) by briefly pressing the 'SET +' or '-' button. The system will allow a maximum of five increments above or below the set speed.

Resuming a Set Speed

If cruise control is cancelled, e.g. by braking, the original set speed can be resumed, provided the set speed memory is not erased.

Caution:

1. **'RESUME' should only be used if the driver is aware of the set speed and intends to return to it.**
2. **It is not recommended that a set speed is resumed in gear position 2 or 3, as excessive engine speeds will occur.**

If the vehicle is accelerated above the set speed the set speed will be resumed gradually when the accelerator is released.

Braking will cancel the cruise control mode. Pressing 'RESUME' gradually increases speed until the set speed is again reached.

Switching Off Cruise Control

1. Press the CANCEL button (speed memory retained).

2. Push the ON/OFF switch down (OFF) (speed memory erased).

Cruise Control Automatic Switch Off

Cruise control will disengage, but not clear the memory when:

- a. The CANCEL button is pressed.
- b. The brake pedal is pressed.
- c. Speed falls below 15 mph (24 km/h) or 50% of set speed.
- d. Neutral, Park or Reverse gear positions are selected.
- e. Traction control or stability control is activated.
- f. The set speed is above 90 mph (144 km/h); cruise control will disengage automatically after approximately 20 minutes.

Cruise control will disengage and clear the memory when:

- a. The ON/OFF switch is set to OFF.
- b. The ignition is switched to position '0'.
- c. The handbrake is applied.
- d. Maximum vehicle speed is reached.
- e. The On-board Diagnostic system detects a malfunction. If a fault occurs the cruise control system will switch OFF and will remain inhibited until the fault is cleared.

Notes On Using Cruise Control

1. Cruise control operates when the gear selector lever is in position '2', '3' '4' or 'D'.
2. When engaged, the accelerator pedal rests in the raised position. If pressed, pedal load will be noticeably less than normal (non-cruise control) driving, until the point at which acceleration starts, then pedal load will return to normal.

Exterior Lighting

All the exterior lights, with the exception of the front and rear fog lamps, are controlled by the left-hand column switch.

Note: The button on the end of the column switch, cycles through the message display functions.

Sidelights, Dipped Headlamps (Low Beam) (except Canada)

The rotary collar has four positions. These are:

OFF Position (A) – All exterior lights OFF.

Sidelights ON (B) – Switches ON front sidelights, tail, number plate and any other marker lights required by local legislation. In this position the sidelight tell-tale will be lit.

Headlamps ON (C) – Switches ON headlamps (with ignition in position 'II') in addition to the lights switched on in position (B).

Auto Headlamps ON (D) - see next page.

If the ignition is switched to position '0', with the rotary collar in the headlamp ON position, sidelights, tail and number plate lights will stay on but the headlamps will switch OFF. When the ignition is again moved to position 'II' they will come on automatically.

Sidelights, Day Time Running Lights (Canada only)

The rotary collar has three positions. These are:

OFF Position (A) – Dipped headlamps, sidelights, tail, number plate and side marker lights will switch ON automatically when the ignition is turned to position 'II'.

Sidelights ON (B) – All the lights switched on in the OFF position (A) will stay on, except the dipped headlamps which will switch OFF.

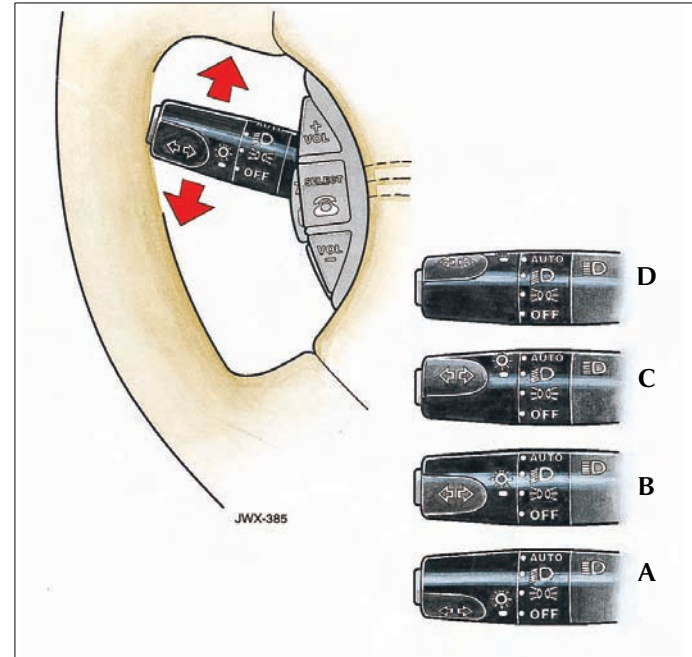

Headlamps ON (C) – This position gives the normal headlamp and sidelight function.

3-24 Instruments - controls

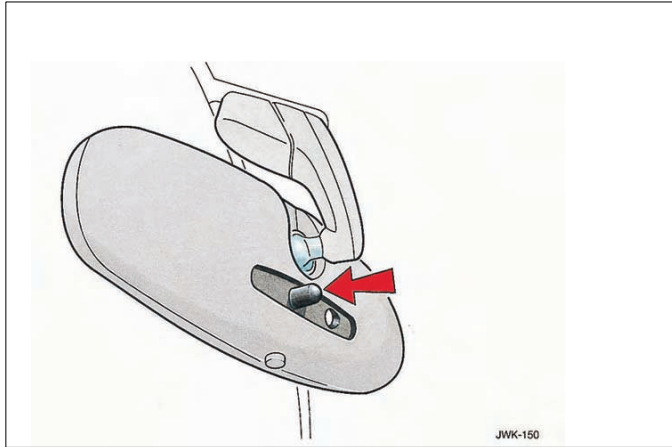

Auto Headlamp (D) (where fitted)

A sensor control mounted on the back of the interior rear view mirror, monitors exterior light levels and automatically switches the sidelights and dipped headlamps ON and OFF.

The ignition switch must be in position 'II' for automatic operation.

To operate: Turn the rotary collar to AUTO.

When light fades to the pre-determined level, the sidelights and headlamps will switch ON after a short delay.

The sidelight tell-tale will light up when the headlamps come on automatically.

As light increases to the pre-determined level, the sidelights and headlamps switch OFF after a short delay.

The sensitivity level can be adjusted by turning the sensor control knob on the back of the interior mirror, anticlockwise to decrease or clockwise to increase when sitting in the driver's seat.

We recommend that the rotary collar on the column switchgear is left on the AUTO position at all times as a convenience feature.

Do not cover the sensor and keep the windscreen clean. Obstructing the light in this area may lead to unwanted operation of the sidelights and headlamps when the switch is set to AUTO.

Headlamp Main Beam (High Beam)

With the lighting switch in the Headlamps ON position (C), push the column switch away from the steering wheel. The blue warning light on the instrument cluster comes ON.

To flash the main beam headlamps, pull the column switch towards the steering wheel. The headlamps will remain ON for as long as the switch is held.

The main beam can be flashed with the ignition ON or OFF and the lighting switch in any position.

Note: Always switch to dipped headlamps when approaching traffic or when driving in urban areas.

Fog Lamps (A and B)

The switches only work when the ignition switch is in position 'II'.

Front Fog Lamp (A): only works with the 'sidelights' or 'headlamps' switched ON.

Note: Front fog lamps should not be used in conjunction with the headlamp main beam (high beam).

Rear Fog Lamp (B): only works with the headlamps switched ON or the front fog lamps switched ON.

Press to switch the fog lamps ON. Press again to switch OFF. Lights at the side of the switches indicate when the fog lamps are ON.

When the sidelights are switched OFF, the fog lamps will automatically be cancelled.

If the sidelights switch is left ON when the ignition switch is turned to position '0', the fog lamps will switch OFF until the ignition switch is returned to position 'II'.

Direction Indicators

The direction indicators operate when the ignition is in position 'II'. To indicate for a right or left turn, move the column switch UP or DOWN respectively. The switch will latch in position and cancel when the turn is completed.

An audible warning and a flashing green warning light on the main instrument cluster indicate that the direction indicators are on.

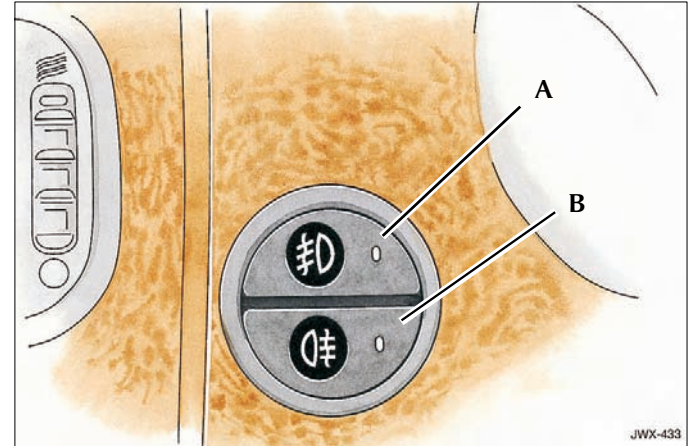

Headlamp Convenience

When approaching the vehicle, the sidelights and dipped headlamps can be switched ON by pressing the 'headlamp' button on the key-ring transmitter.

The lights will come ON for 25 seconds or until the 'headlamp' button is pressed again.

Bulb Failure Monitoring

The tail and brake light bulbs are monitored for failure.

Message: **Check Rear Lights** Priority Indicator: **Amber**

3-26 Instruments - controls

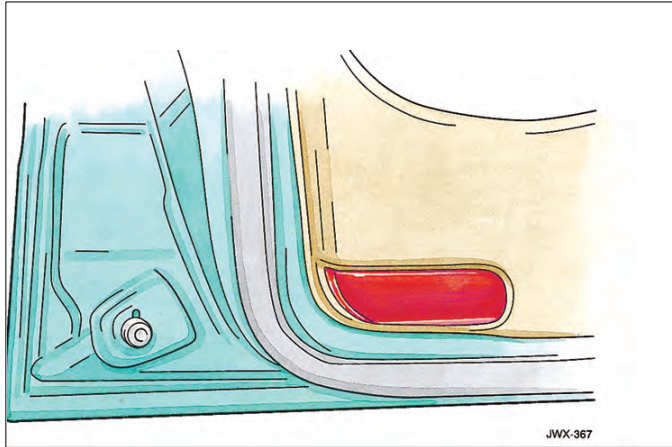

Door Guard Lights

Door guard lights are fitted to each door to illuminate the 'step-out' area at night and to give warning of an open door to passing vehicles.

The light comes ON automatically when the door is opened and switches OFF when the door is closed.

If the door is left open the light remains ON for 5 minutes and then switches OFF.

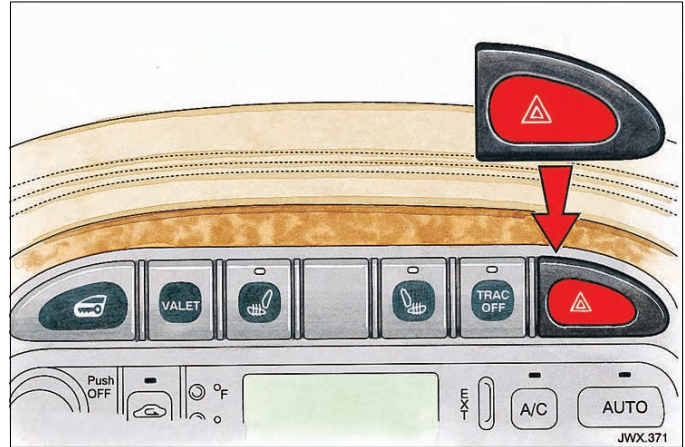

Hazard Warning Switch

The switch is in the centre console switch pack and operates with the ignition ON or OFF.

To operate: Press the switch; the direction indicators, repeaters (where fitted), tell-tales and audible warning will operate in unison. The switch will light up.

To cancel: Press the switch again.

Interior Lighting

Three interior lights are fitted, one in the roof console, and one in each rear quarter.

All interior lights fade on and fade off when switched. For driver convenience, the lights operate in the following manner:

The lights come on when any door is opened, and go out when all doors are closed. A 15 second delay occurs after closing the last door; the lights will go out immediately when the engine is started.

With the doors closed, the lights can be switched on by pressing the switch in the roof console.

Interior lights come on for 15 seconds when the doors are unlocked with the key-ring transmitter.

If any door is left open, the lights will stay on for 2 minutes.

With the engine running, opening any door will put on all interior lights, they will go out immediately the last door is closed.

When the vehicle is unlocked by either key or key-ring transmitter, the lights will come ON at $\frac{3}{4}$ maximum brightness (for a maximum of 2 minutes if the door is not opened) and then switch to maximum brightness when a door is opened.

Note: The luggage compartment, vanity mirror and glove box are illuminated when in use. These lights and the map lights will work for up to 15 minutes after the ignition has been switched to position '0', if no other switch is operated.

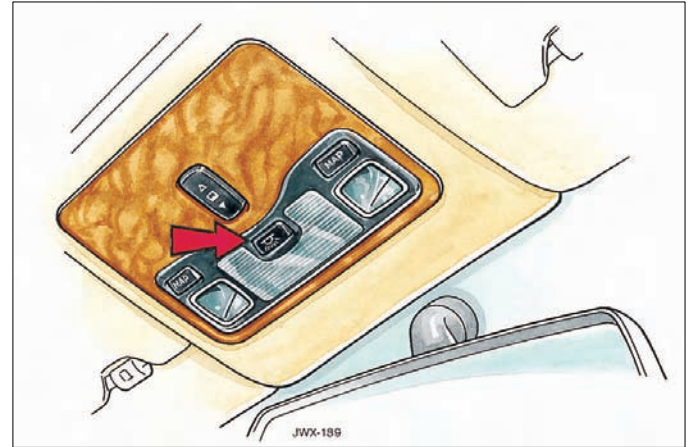

3-28 Instruments - controls

Reading Lights

The vehicle is equipped with four reading lights, two positioned in the roof console on either side of the interior light, and one each side in the rear quarter panels as the upper part of the rear interior light units.

Each reading light is switched individually.

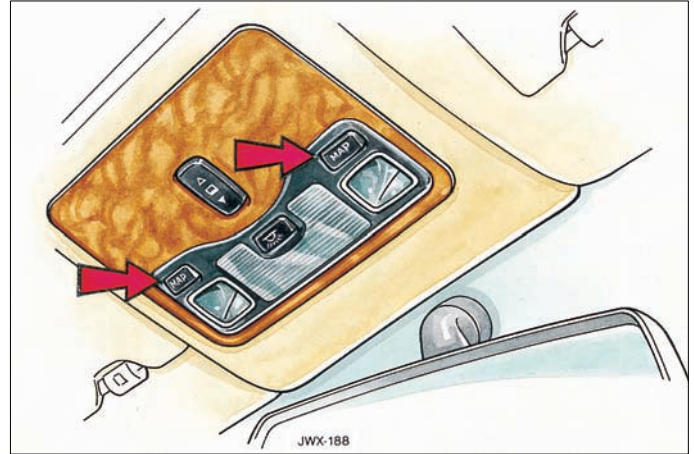
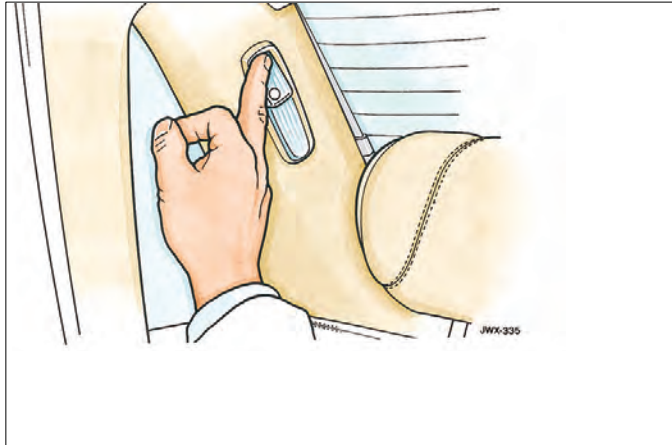

Front reading lights are operated by the switches marked 'MAP' in the roof console, and the rear reading lights by pressing the upper lens of the interior light unit.

Window Operation

Four switches on the driver's door switch pack control the driver and passenger door windows. The passengers are provided with a switch to control the passenger door window only.

The button (A) immobilises the rear passenger window switches.

These switches only operate when the ignition switch is in position 'I' or 'II'.



WARNING:

1. When raising windows ensure all occupants are clear.
2. When leaving the vehicle take the ignition keys to prevent misuse of the window switches by remaining occupants, especially children.
3. Obstruction detection is not available.

Operation

To open: Press and hold the lower part of the switch. Release the switch to stop movement.

To close: Press and hold the upper part of the switch. Release the switch to stop movement.

Note: If the switches are held for longer than 12 seconds, e.g. when attempting to overcome frozen or jammed windows, the window drive will be switched off for a few seconds to protect the window drive motors.

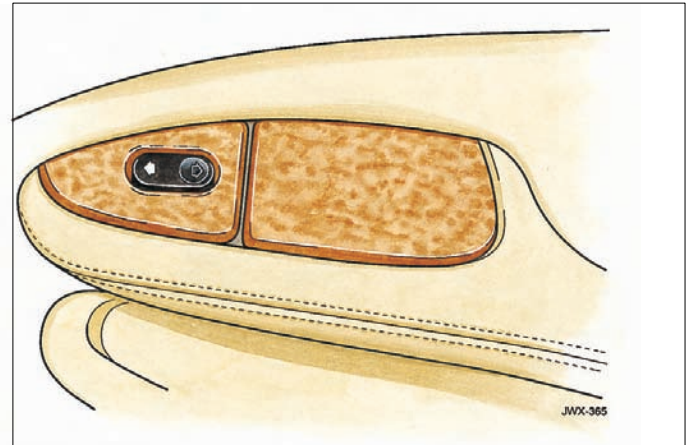
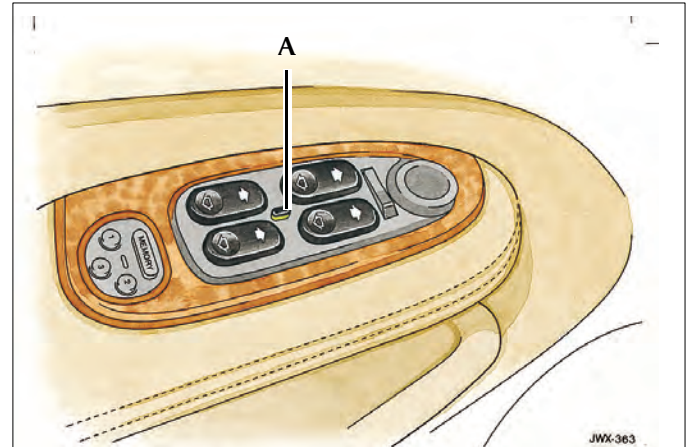

3-30 Instruments - controls

Window Operation (continued)

One-Touch Operation

All window switches have a 'one-touch' facility enabling the occupants to fully open the windows in one quick movement.

To open: Briefly press and release the bottom of the switch. Window travel can be stopped by pressing the switch again.

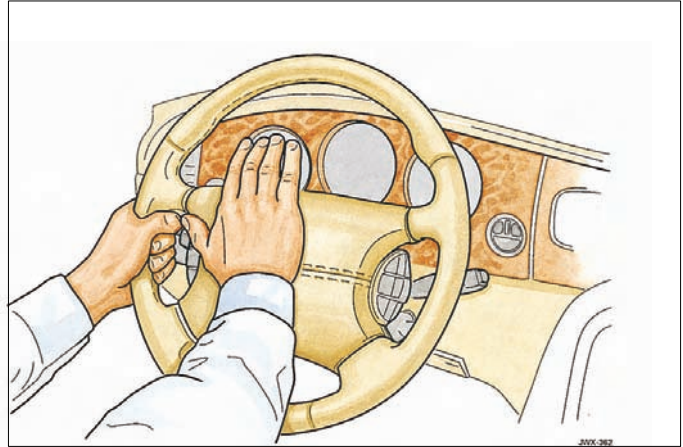

Horns

Twin warning horns are operated by pressing the centre pad on the steering wheel.

The horns will work with the ignition switch in any position.

Windscreen Wiper and Washers

The windscreen wiper and screen wash functions controlled by the right-hand column switch, only operate with the ignition in position 'II'.

The functions are as follows:

Position '0' (A): The windscreen wiper blade is OFF and parked.

First position (B): Intermittent wipe.

Second position (C): Normal wiper operation.

Third position (D): High speed wiper operation.

Intermittent Wipe

When intermittent wipe is selected (first position) the rotary collar can be adjusted to vary the delay between wipes. Five collar positions vary the delay from 2 seconds to 20 seconds. Turn the collar anti-clockwise to increase the delay time.

If flick wipe or wash/wipe is selected between intermittent wipes, the intermittent mode will be interrupted temporarily.

Flick Wipe

Pull the column switch towards the steering wheel for a single slow speed wipe. Holding the column switch in this position will operate the wiper continually at slow speed until released.

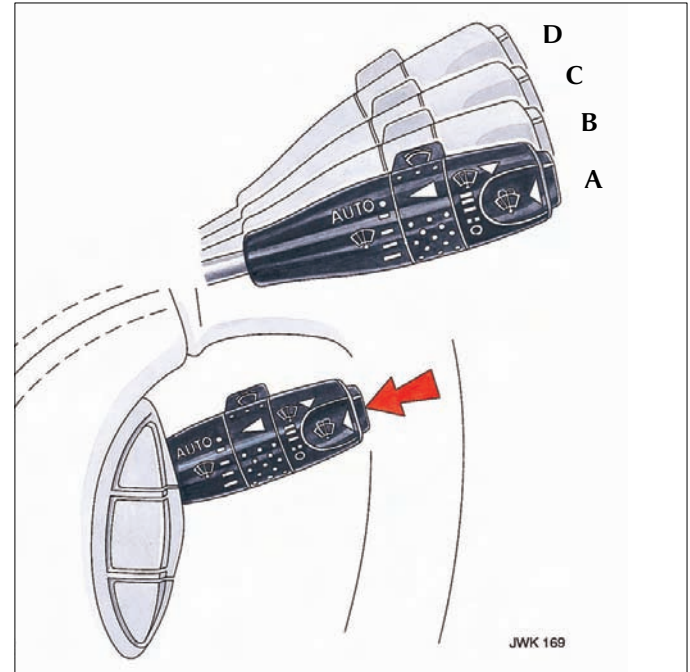

3-32 Instruments - controls

Rain sensitive wiper operation (where fitted)

When AUTO, turn the rotary collar to AUTO, and intermittent wipe, position (B page 3-31), is selected, the wipers will automatically operate to clear the windscreen when rain falls on to the windscreen, or when moisture is present.

Note: When starting a journey with a wet windscreen, the rain sensing wipers will not operate immediately the ignition is switched on, therefore, a flick wipe should be used to clear the screen of any moisture.

Caution: Ensure that AUTO is not selected when entering a car wash or damage to the wiper blades/arms can occur.

Programmed Wash/Wipe

Push the button on the end of the column switch to obtain the wash/wipe programme. A short press will operate the washers briefly and the wiper will complete three wipes. If the button is held, the washers and wiper will operate continuously for up to 20 seconds.

When released, the wiper will complete three wipes after the washers have stopped. The drip wipe function will perform a single wipe 4 seconds after the wash/wipe sequence has finished.

When the washer fluid is low, a message is displayed, and the programmed wash/wipe function is disabled. Manual operation is still available.

Message: **Washer Fluid Low** Priority Indicator: **Amber**

Headlamp Powerwash (where fitted)

Note: The headlamp powerwash units are mounted on the front bumper.

The headlamp powerwash feature will operate if the ignition is in position 'II' and the lighting switch is in the dipped or main beam position (C page 3-31). It will not operate if the washer fluid level is low (indicated by the message centre).

When the windscreen wash/wipe button is pressed, the headlamp powerwash directs two short bursts, approximately 3 seconds apart, at the headlamp cluster. If the wash/wipe button is held, the powerwash cycle will continue for up to 20 seconds.

The headlamp powerwash will operate the first time the wash/wipe button is pressed and thereafter every sixth succeeding wash/wipe operation. If the sidelights or ignition are switched OFF and ON again, headlamp powerwash will operate on the next press of the wash/wipe button.

Audible Warnings

Audible warnings alert occupants to possible hazards or conditions.

Hazard or Condition	Audible Warning	Remedy
Direction indicators ON.	Ticking. (This will sound at twice normal rate if a bulb fails).	Move left-hand column switch to the centre position when the manoeuvre is complete.
Hazard warning indicators ON.	Ticking. (This will sound at twice normal rate if a bulb fails).	Press hazard warning switch again.
Driver's door opened with the key in the ignition switch (Position '0' or '1').	Continuous high-pitched chime.	Remove the key or close the driver's door.
Driver's door opened when the sidelights or headlamps are ON (with the key removed from the ignition switch).	Intermittent slow, high-pitched chime for 10 seconds.	Switch the lights OFF or close the driver's door.
Park not selected with the ignition OFF.	Rapid interrupted low-pitched tone for 10 seconds.	Move the gear selector to 'P' Park.
Driver's seat belt unfastened with the ignition switch in position 'II' (Middle East markets only).	Continuous 6 second tone.	Fasten driver's seat belt or switch ignition to position '0'.
Luggage compartment release switch pressed when in valet mode or valet switch pressed when the luggage compartment is closed.	Low-pitched 1 second tone.	
Seat memory set or recall completed.	Single chime for 1 second.	

3-34 Instruments - controls

Hazard or Condition	Audible Warning	Remedy
Airbag system failure. (The audible warning only sounds in the event of airbag warning light failure.)	Five groups of high-pitched tones every 30 minutes	Report the fault as soon as possible to the nearest Jaguar dealer.

Front Seats and Head Restraints - Adjustment



WARNING:

1. Do not make adjustments when the vehicle is moving.
2. Front passengers must not ride with the seat reclined.

The front seats can be adjusted electrically by three switches on the side of the seat cushion. Conditions for adjustment are:

- The associated door open or within 30 seconds of closing.
- Key in ignition switch and gear selector in Park or Neutral (see Note 2).

Switch A controls the seat cushion position as follows:

Forward or Rearward – Move the switch forwards or rearwards.

Raise/lower cushion – Move the switch up or down.

Switch B controls the seat back angle and head restraints as follows:

Move the switch rearwards to recline or forwards to raise the seat back angle.

Move the switch upwards to raise and downwards to lower the head restraint.

The head restraint can be tilted through 45° by pushing backwards or pulling forwards into the desired position.

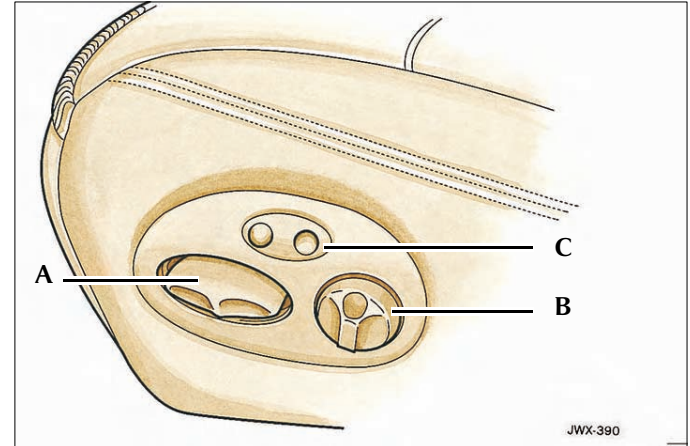

Switch C controls the lumbar support as follows:

With the ignition switch in position 'I' or 'II', press the front of the switch to increase support or the rear of the switch to reduce support.

Notes on adjustment of seats:

1. Driving position adjustments must not be made whilst in entry/exit mode.
2. When the gear selector is not in Park or Neutral, seat movement is limited to a maximum of 2 seconds to allow only minor adjustments.
3. With the associated door open the switches are operable. This is to allow adjustment before entering the vehicle, if required.

4-2 Pre-driving

Seat Heaters (where fitted)

Note: Storage of the vehicle in a heated garage, body heat or warm ambient temperatures may prevent operation of the seat heater.

Front Seat Heaters

Each front seat back and cushion has a heater controlled by a switch on the centre console. This function operates when the engine is running.

To operate: Press the switch. A light will show when the heater is ON.

The heater will only operate if the temperature of the seat is below the pre-set temperature of the thermostat.

To cancel: Press the switch again.

If the engine is not producing sufficient electrical power the heaters will only remain on for 10 to 12 minutes to avoid discharging the battery

Rear Seat Heaters – Fixed Seats

Each side of the rear seat back and cushion has a heater, controlled by switches located on a rear-facing extension to the front armrest console. This feature only operates when the ignition switch is in position 'II'.

To operate: Press the switch.

A timer in the circuit limits the operation of the heater to 10 – 12 minutes, which will only operate if the temperature of the seat is below the pre-set temperature of the thermostat.

To cancel: Press the switch again.

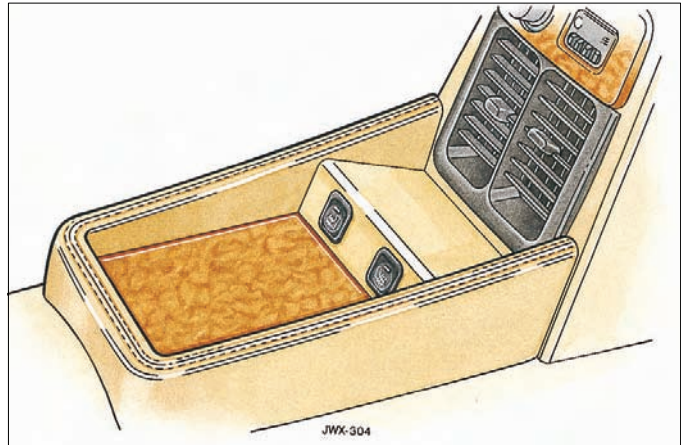
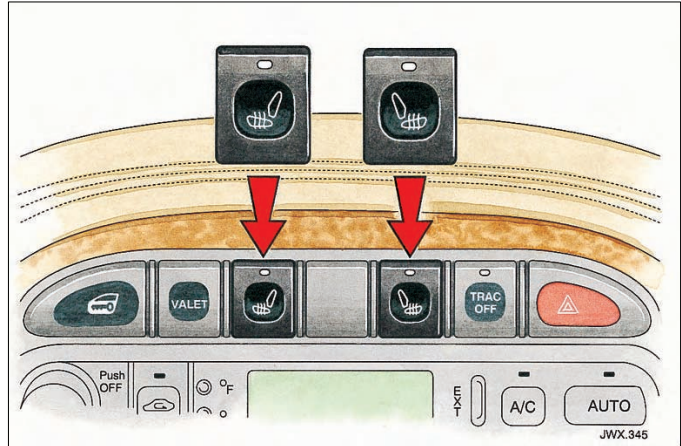

Driving Position Memory System (where fitted)

Setting a Driving Position (Memory Set)

The position of the driver's seat, steering column and exterior rear view mirrors can be memorised and recalled. Three different driving position profiles can be entered in the memory. Storing a driving position profile in the memory can only be achieved with the key in the ignition switch.

1. Adjust the seat, steering column and exterior rear view mirrors to the desired position.
2. Push the memory button, the light in the switch pack next to the button will come on for a 4 second period, during which time the driving position profile must be entered.
3. Push the button '1', '2' or '3' to memorise the configuration. The memory button light will go out and a chime will indicate that the setting procedure is complete.

By repeating these three steps and pressing the unused button ('1', '2' or '3'), a further driving position can be stored in the memory.

To set a new driving position, adjust to the desired position and perform steps 2 and 3. The previous memory will be erased and the new position will be set.

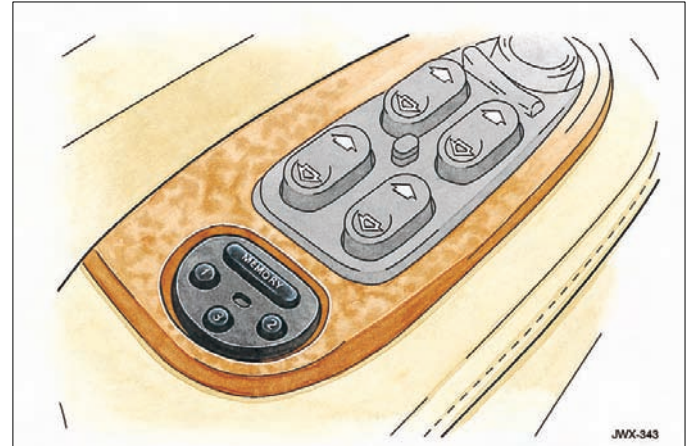

Recalling a Memorised Position

Recalling a memorised position can only be made if:

- The driver's door is open or within 30 seconds of it closing.
- The key is in the ignition switch.
- The gear selector is in Park or Neutral.
- The key-ring transmitter is used (if it is programmed for memory recall).

To recall a memorised position: Press and release the appropriate memory button ('1', '2' or '3'). The seat, steering column and door mirrors will move automatically to the memorised position.

4-4 Pre-driving

Memory Recall Using Key-ring Transmitter

The key-ring transmitter may already be programmed to recall a memory position. This will occur when the unlock button is pressed. If the key-ring transmitter is not programmed, then to programme, proceed as follows:

- With the key in the ignition switch, follow the memory setting procedures 1, 2 and 3 on the previous page.
- Within 5 seconds, press any button on the key-ring transmitter. The memory light will flash and a chime will confirm programming.
- Once programmed, the key-ring transmitter will recall the memory position when the unlock button is pressed.

Note: The memory position can be altered without having to re-programme the transmitter.

To cancel key-ring transmitter memory recall:

- With the key in the ignition switch, press the memory set button.
- While the memory set light is ON, press any button on the key-ring transmitter twice. The memory light will go out and two chimes will confirm that the programming has been cancelled.

Driving Position Memory System Operating Tips

- When making adjustments to a set driving position, reset the new position in the same memory channel.
- A driving position will only be memorised if the key is in the ignition switch and the memory button light is ON (4 second period).
- Previous memory is erased when a new driving position is entered.
- Memorised driving positions cannot be recalled unless the gear selector is in Park or Neutral.

Front Passenger Seat Movement from the Rear Seat (Where fitted)

The front passenger seat can be moved forwards or rearwards and the seat back reclined or moved to the upright position by the rear seat passenger, using two switches which are located on the front passenger seat side or back panel.

To move the seat forwards: Press the top of the lower switch.

To move the seat rearwards: Press the bottom of the lower switch.

To recline the seat back: Press the bottom of the upper switch.

To move the seat back to the upright position: Press the top of the upper switch.

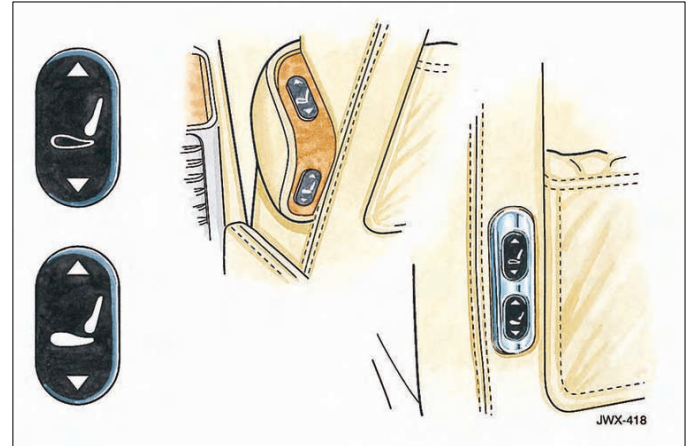

Head Restraints (Rear Seats)

Adjustable head restraints, fitted to both outer seating positions, are adjustable for height.

To raise or lower: Lift the head restraint upwards or push downwards to the desired height – the two stems will engage in one of four positions.

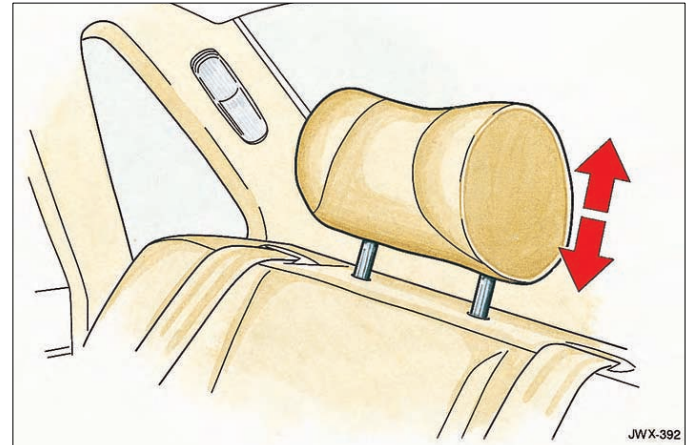

4-6 Pre-driving

Steering Column Tilt and Reach Adjustment Electrical Operation



WARNING:

Do not adjust the steering column whilst driving.

The steering column can be adjusted for tilt and reach by operating the four-way control switch on the steering column.

To adjust the steering column the key must be in the ignition switch. Adjustments can also be made when the driver's door is open or within 30 seconds of closing it.

Moving the switch forwards and backwards controls steering column reach. Moving the switch up and down controls tilt.

Entry/Exit Mode – Steering Column Tilt Away

Entry/exit mode is selected by setting the steering column adjustment switch to the 'Auto' position.

When the key is removed from the ignition switch or the ignition switch is in position '0' or 'I' and the driver's door is open the steering column will move to the tilt away position, which is its uppermost tilt and innermost reach position.

The steering column position before tilt away is memorised.

When the ignition key is next inserted in the ignition switch or the door is closed when the ignition switch is already in position '0' or 'I', the steering column will move back to its previously programmed position.

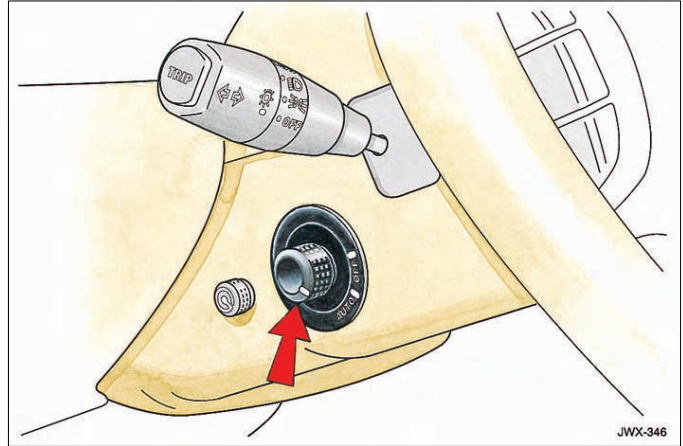

If a new driving position memory is selected by pressing one of the memory buttons or unlocking the vehicle with the key-ring transmitter (if programmed), whilst the steering column is tilted away, the steering column will tilt back to the new selected driving position when the key is next inserted in the ignition.

Notes on entry/exit mode operation:

1. If the adjustment switch is moved away from 'Auto' whilst the steering column is tilted away, the steering column will move back to its memorised position when the key is next inserted in the ignition and the feature is then cancelled.
2. If the adjustment switch is moved during entry/exit operation, steering column movement will stop.

Rear View Mirrors

The interior rear view mirror is of the electrochromic type, and is operated by the control button at the base of the mirror. Where electrochromic door mirrors are fitted, they are operated in conjunction with the interior mirror by the same control.

The door mirrors have heating elements which work when the rear screen heater is switched ON. The mirror heater will clear all ice from the mirror surface.

Caution: Do not use a scraper as this will damage the surface of the mirror.

Each mirror housing, except the Power Fold Back Door Mirror, is designed to pivot rearwards against the vehicle body. To return the mirror to its normal position, reposition the housing until it locks into place.

Door Mirror Dipping – Reversing (Vehicles with memory function – where fitted)

To give the driver a clear view of the kerb when reversing, the passenger's door mirror can be dipped without erasing the memorised mirror position.

To operate: With the selector switch in either the left or right position and reverse selected, move the mirror adjustment button rearwards and release (one-touch operation). The mirror will dip by 7°. The mirror will return to its memorised position when reverse gear is deselected, or the ignition is switched to position '0'.

Moving the adjustment button rearward and forward with reverse gear selected will dip and return the mirror as required.

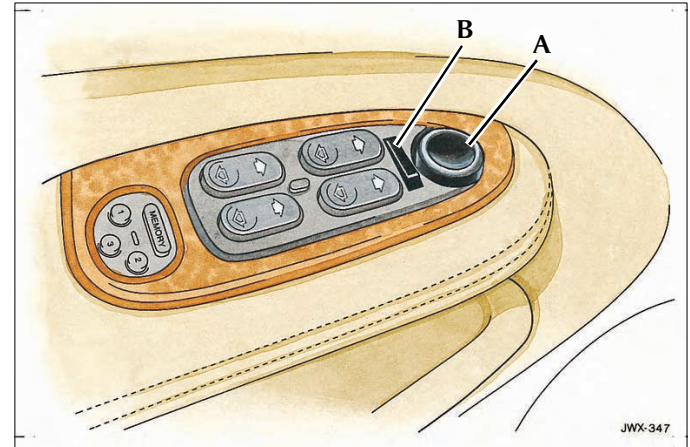

Door Mirror Adjustment

To adjust the door mirrors the key must be in the ignition switch. Adjustments can also be made when the driver's door is open or within 30 seconds of closing it.

Both door mirrors are adjusted from the driver's door switchpack. The four-way adjustment button (A) moves the selected mirror to the required position. The selector switch (B) selects the mirror to be moved:

Far left position for the left-hand mirror.

Far right position for the right-hand mirror.

When the selector switch is in the centre position, adjustment to either mirror is inhibited.

4-8 Pre-driving

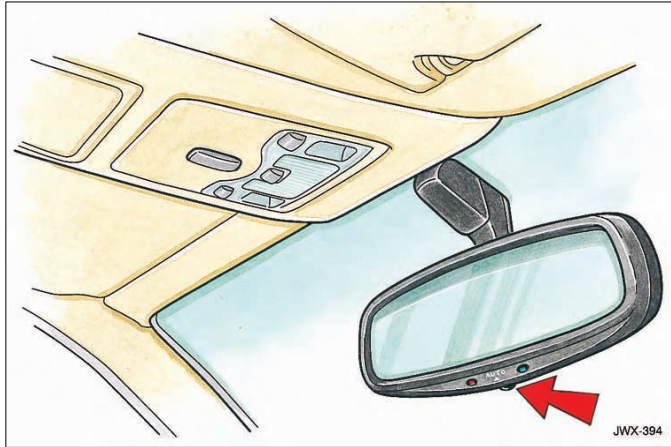

Interior Rear View Mirror

Note: Should the mirror assembly become detached from the windscreen, it must be refitted by a Jaguar dealer.

The interior rear view mirror is of the electrochromic type, and is operated by the control button at the base of the mirror.

When switched on, the mirror darkens automatically to prevent glare from a following vehicle's headlamps, and clears when light levels return to normal or when reverse gear is selected.

Where electrochromic door mirrors are fitted, they are operated in conjunction with the interior mirror by the same control, and function in the same manner.

To operate: To switch ON, press the control button. An LED lights up to indicate that automatic operation is selected. Press again to switch OFF.

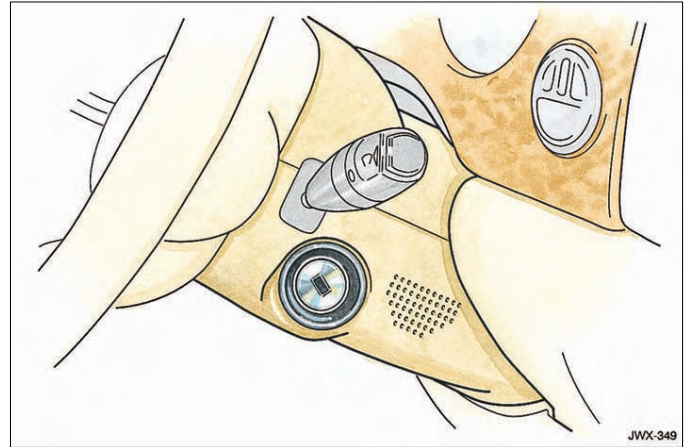

Ignition/Starter Switch and Steering Lock

This switch is on the right-hand side of the steering column. It is operated through four positions by the ignition key.

Note: Should any warning lights or warning messages stay on after starting the engine, the cause must be investigated before driving off.

0. The only position in which the key can be inserted or removed. When the key is out, the steering lock is engaged.
1. **Auxiliary position:** Certain circuits, i.e. radio, windows, can be operated without switching on the ignition.
- II. **Ignition position:** All circuits except the starter motor are actuated. The key remains in this position when driving.

III. **Start position:** The starter motor is operated for as long as the key is held in this position, against spring pressure.

If the engine fails to start the key must be returned to position 'I' before another start is attempted.

Gear-shift Interlock

A brake pedal/gear-shift interlock system is incorporated in the gear selector mechanism.

To Disengage Steering Lock and Start Engine

Insert the key and turn clockwise. If resistance is felt, turn the steering wheel slightly to release the steering lock.

Turn the key to position 'II' to switch on the ignition.



WARNING:

Before attempting to start the engine, check handbrake is ON and gear selector lever is in position 'P' or 'N'.

To start the engine, turn the key to position 'III'. When the engine starts, release the key which will return to position 'II'.

Note: Do not depress the accelerator pedal whilst operating the starter motor.

Do not use the starter continuously for longer than 6 seconds. Wait until the engine stops before re-using the starter.

If the engine persistently fails to start and flooding is suspected, slowly depress the accelerator pedal fully, hold it in this position and start the engine. Release the pedal when the engine starts.

If the engine still fails to start, switch the ignition OFF and contact a Jaguar Dealer. Continued use of the starter will discharge the battery and may also damage the starter mechanism.

If the ignition circuits are isolated, the fuel system inertia switch may have tripped.



WARNING:

Never switch OFF the (ignition) engine whilst the vehicle is in motion as the steering lock may operate.

Due to the installed starter non-repeat feature, the key must be turned to position 'I' before attempting to start the engine again.

The red ignition warning light should go out when the engine is running.

To Stop Engine and Lock Steering

Turn the key from position 'II' to the 'lock' position '0'. This stops the engine.

The ignition key cannot be removed from the ignition switch/steering lock unless the gear selector lever is in position 'P'.

Once the ignition key has been removed the gear selector lever will be locked in position 'P'.

A manual release mechanism will allow the gear selector lever to be unlocked from the 'P' position in the event of electrical failure or when moving the vehicle without power (i.e. towing).

Removal of the ignition key actuates the steering lock. Slight movement of the steering wheel may be needed to engage the lock fully. Always remove the keys when leaving the vehicle. Leaving the key in position 'I' will discharge the battery.

4-10 Pre-driving

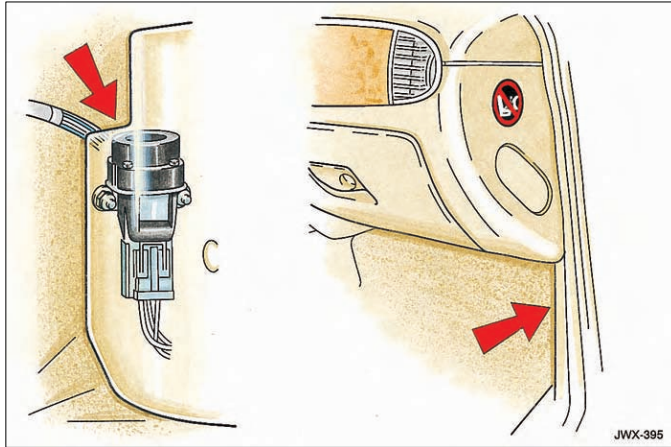

Fuel Cut-off Switch

In the event of an accident, an inertia switch will trip, isolating ignition controlled circuits, including fuel pump operation. Simultaneously, the doors will automatically unlock. Once the switch has tripped it must be reset before attempting to restart the engine.

Note: The doors will not unlock if the inertia switch is tripped when the ignition switch is in position '0'.

The inertia switch is located in the right-hand side front footwell behind the footboard carpet as shown on the illustration. A button on the top of the switch, under a flexible cover, is raised when the switch has been tripped.

Resetting the switch



WARNING:

To avoid the possibility of fire or personal injury, do not reset the inertia switch if you see or smell fuel.

If no fuel leak is apparent, reset the inertia switch as follows:

1. Turn the ignition switch to position '0'.
2. Press down the flexible cover on the top of the inertia switch.
3. Turn the ignition switch to position 'II', pause for a few seconds, then return the key to position '0'.
4. Make a further check for fuel leaks.

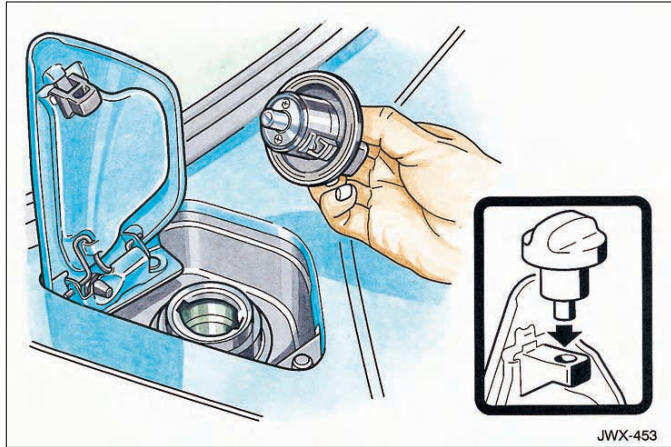

Fuel Filler Flap and Cap

The fuel filler is on the left-hand side of the vehicle.

Ensure that the doors are unlocked. Lift the filler flap fully up. Turn the filler cap anti-clockwise and remove. Place the cap in the storage provided on the filler flap.

After refuelling, refit the filler cap and close the flap. The flap locks when the vehicle is locked by using the key or key-ring transmitter.

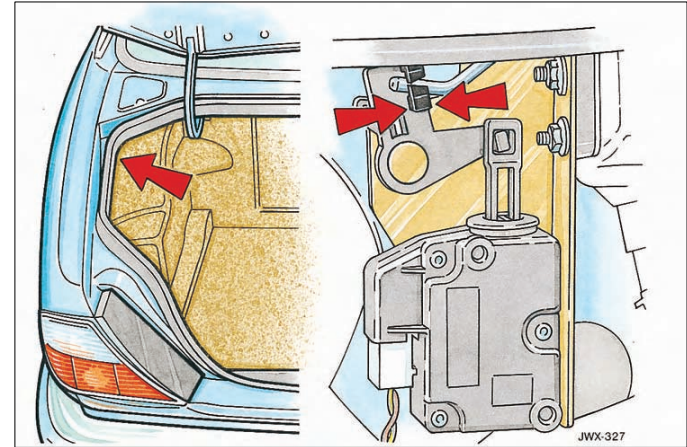

Fuel Filler Flap Manual Lock/Unlock

If the fuel filler flap fails to operate it can be manually locked or unlocked as follows:

1. Remove the luggage compartment lining at the rear on the left-hand side below the filler.
2. Reach up and locate the fuel filler flap mechanism. Pull back the lock plunger linkage to unlock the filler flap and push the linkage forward to lock.

Report the fault to a Jaguar Dealer.

4-12 Pre-driving

Fuel Tank Filling

Before refuelling, switch off the ignition and remove the key.

Note: Do not leave the ignition key in the vehicle; vehicles have been stolen from garage service/filling stations whilst the driver is absent from the vehicle. It is recommended that the vehicle is locked, if left unattended.



WARNING:

- 1. Fuel vapour is highly flammable and in confined spaces is explosive and toxic. In the event of inadvertent spillage, and before refuelling, always switch OFF the engine. Do not use exposed flame or light. Do not smoke. Do not inhale fumes.**
- 2. Do not fill the tank so that fuel is visible in the fuel filler intake tube. This could cause spillage and danger from exposed fuel.**

Caution:

- 1. Take care to not spill fuel during refuelling. Fuel containing alcohol can cause paint damage, which may not be covered under the warranty.**
- 2. Vehicles with engines fitted with catalytic converters must only be filled with 'Unleaded Fuel'.**

When filling, the dispenser nozzle must be inserted into the filler neck sufficiently to open the trap door for fuel to flow into the fuel tank. Fill the tank until the filler nozzle automatically shuts off. Filling beyond this point could result in fuel spillage.

Always use a high quality fuel which contains detergent and other additives. These will help to protect the engine components against corrosion and carbon deposit formation, and prevent contamination of the fuel injection system.

The continuous use of high quality fuel makes the need for additional additives unnecessary.

Fuel Requirements

See **Fuel Requirements** in SECTION 6 of the Vehicle Care Handbook for information on recommended types and grades of fuel. If in doubt your local Jaguar Dealer will advise on which fuel must be used in your vehicle.

Fuel Quality

The use of high quality fuel containing 'intake system deposit control' detergent and other additives will help to keep the vehicle's intake system free of deposits and its fuel system free of corrosion and gumming. If high quality fuels containing 'intake system deposit control' detergent and other additives are used continuously, there should be no need to add any after market products to the fuel tank.

If problems are experienced with starting, rough idling or hesitation when the engine is cold, it may be caused by gasoline with a low volatility. Try a different grade and/or brand of fuel. If the condition persists, see a Jaguar Dealer or a qualified service technician.

Oxygenated gasoline

Fuels that are blended with compounds containing oxygen, called oxygenates, may be used. Common oxygenates are ethanol or grain alcohol (blended at no more than 10%), methanol or wood alcohol (blended at no more than 5% with necessary co-solvents and additives, and MTBE or methyl tertiary butyl ether (blended at no more than 15%). The type of oxygenate may be found on the fuel pump or by asking the attendant. In certain areas of the country, oxygenates are required to be in all fuels to help improve air quality.

Generally, difficulty should not be experienced while operating the vehicle on fuels containing oxygenates. If problems are experienced switch to a fuel with a different type of oxygenate, or switch to a fuel that does not contain oxygenates, if available.

Reformulated gasoline

Several petroleum companies have announced the availability of reformulated fuels.

These fuels are specially designed to further reduce vehicle emissions.

Jaguar fully supports all efforts to protect and maintain ambient air quality, and encourage the use of reformulated gasoline, where available.

4-14 Pre-driving

Occupant Protection – Seat Belts and Airbags

This vehicle has lap/shoulder inertia reel seat belts and an airbag supplementary restraint system for the driver and front passenger seats. The rear seat has lap/shoulder inertia reel seat belts.

The use of front and rear seat belts is mandatory in most countries.

Using seat belts saves lives. They should be worn by all occupants whenever the vehicle is in use, for maximum protection.

Seat Belts

The inertia operating mechanism of the seat belts allow the wearers to move their upper bodies to reach various controls. The seat belts will lock automatically with accelerated body movement or in the event of emergency braking.

The only adjustment required is for shoulder height. Correct tension is controlled by automatic retraction of the reel.

A warning light on the instrument panel comes on and warning signal sounds for six seconds when the driver's seat belt is not fastened.

The use of comfort clips or devices that would create slackness in the seat belt system are not recommended.



WARNING:

- 1. Seat belts are designed to bear upon the bony structure of the body, and must be worn low across the front of the pelvis, chest and shoulder. Wearing the lap section of the belt across the abdominal area must be avoided.**
- 2. Seat belts should be adjusted as firmly as possible, consistent with comfort, to provide the protection for which they have been designed. A slack belt will greatly reduce the protection afforded to the wearer.**
- 3. Care should be taken to avoid contamination of the webbing with polishes, oils and chemicals, and particularly battery acid. Cleaning may safely be carried out using mild soap and water. The belt should be replaced if webbing becomes frayed, contaminated or damaged.**
- 4. It is essential to replace the entire assembly after it has been worn in a severe impact even if damage to the assembly is not obvious.**
- 5. Belts should not be worn with straps twisted.**
- 6. Each seat belt assembly must only be used by one occupant; it is dangerous to put a seat belt around a child being carried on the occupant's lap.**
- 7. No modifications or additions should be made by the user which will either prevent the seat belt adjusting devices from operating, or prevent the seat belt assembly from being adjusted to remove slack.**

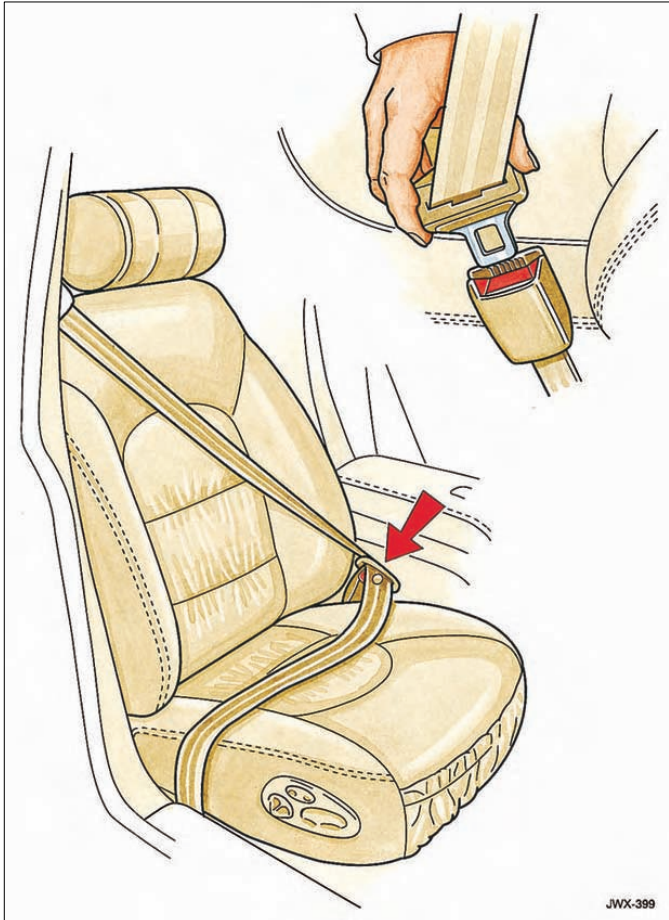

JWX-399

Front Seat Belt Fitting and Adjustment

Draw the tongue of the seat belt over the shoulder, across the chest and push it into the buckle unit slot. A positive 'click' indicates that it is safely locked.

Always ensure that the webbing is midway between the neck and the edge of the shoulder.

To release the harness, press the button on the buckle unit and allow the belt to retract into the reel.



WARNING:

Should the seat belt not retract and remain at its static length, consult your nearest Jaguar Dealer immediately.

Shoulder Height Adjustment



WARNING:

Do not adjust the seat belt or anchorage point while driving.

An adjustable anchorage point (see illustration on next page) is provided to ensure that the seat belt webbing can be positioned to pass over the shoulder without pulling against the neck.

To operate: Press the locking button and slide the anchorage point to the required position to ensure comfort and safety. Release the button and check that the anchorage point is locked.

Always ensure that the webbing is midway between the neck and the edge of the shoulder.

Always check the anchorage point after the seat has been adjusted to ensure that the belt is correctly positioned.

4-16 Pre-driving

Rear Seat Belts Fitting

The belts are of the lap/shoulder reel inertia type. Draw the tongue of the seat belt over the shoulder, across the chest and push it into the buckle slot nearest the wearer. A positive 'click' indicates that it is safely locked.

Always ensure that the webbing is midway between the neck and the edge of the shoulder.

To release the harness, press the button on the buckle unit and allow the belt to retract into the reel.

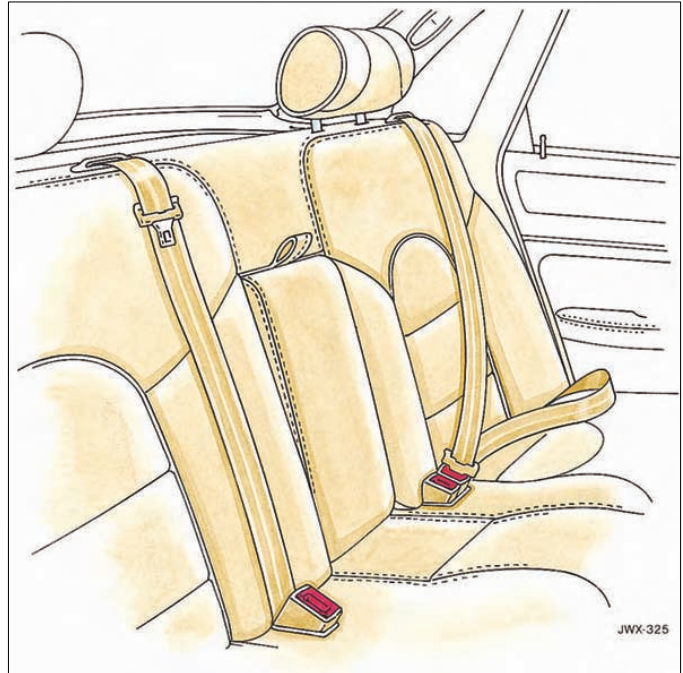
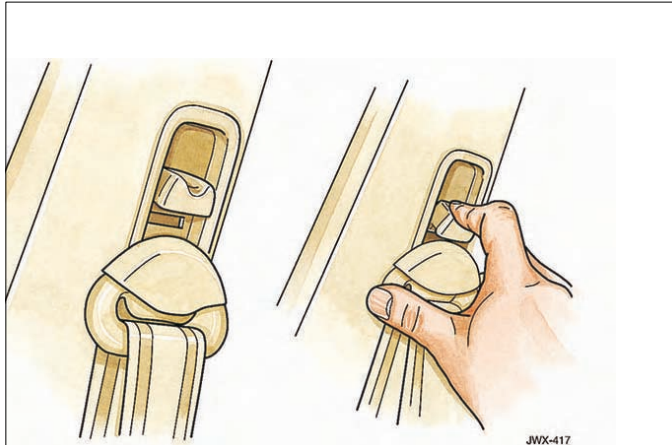

Inertia Reel Mechanism Check

To provide the users with maximum freedom during normal driving conditions, the seat belts are inertia reel type. Hard braking, fast cornering or belt movement locks the belts immediately.

Static test: Whilst seated, fasten the seat belt and grip the shoulder belt at approximately shoulder level with the opposite hand. Pull the belt sharply downwards, the belt should lock.

Road test: The following road test must be carried out only under maximum safe road conditions.

With the seat belt fitted to the driver and passenger(s), as previously described, drive the vehicle at 8 km/h (5 mph) and, ensuring that it is safe to do so, brake sharply.

The seat belt(s) should lock automatically, holding both driver and passenger(s) securely in position.

It is important when braking that the reactions of both driver and passenger(s) are normal, i.e. the body must not be thrown forward in anticipation, thus causing a 'snatching action of the belt which would operate the locking mechanism'.

If the belt fails to lock on either test, consult a Jaguar Dealer.

Note: If the vehicle is parked on unlevel ground, the seat belt mechanism may lock. This is not a fault, ease the belt from its attachment to fit.

Care of Seat Belts

Avoid contaminating the webbing with polishes, oils and chemicals.

The belts must not be allowed to rub against seats or bodywork. Seat belts that have been cut, frayed, damaged or used in vehicles involved in accidents must be renewed.

Cleaning

An occasional wipe with a warm soapy sponge will keep the seat belts clean. Do not use bleach or dye, otherwise the efficiency of the seat belts will be impaired.

4-18 Pre-driving

Airbags

In order to provide optimum protection this vehicle is equipped with four airbags, driver, front seat passenger and side airbags. **They are supplemental to seat belts which should be worn by all occupants whenever the vehicle is in use, for maximum protection.**

The driver airbag is located in the centre of the steering wheel, the front seat passenger airbag is located in the fascia panel immediately in front of the passenger seat and the side airbags are fitted in the side of the driver and front passenger seats within the outboard seat bolster.



WARNING:

- 1. No objects whatsoever should be attached to the centre cover of the steering wheel, the passenger fascia panel or the sides of the driver and front passenger seats.**
- 2. Child seats and passenger airbag:**
Children of 12 years old and under can be killed or seriously injured by the airbag. The rear seat is the safest place for children.
DO NOT install a rearward-facing child seat in the front passenger seat position. This is emphasised by the label displayed on the end of the fascia on the front passenger side, as shown on the illustration.
If however, you must sit a child in the front passenger seat use only a forward facing child seat with the passenger seat set fully rearward. Always follow the fitting instructions supplied with the appropriate child restraint system.

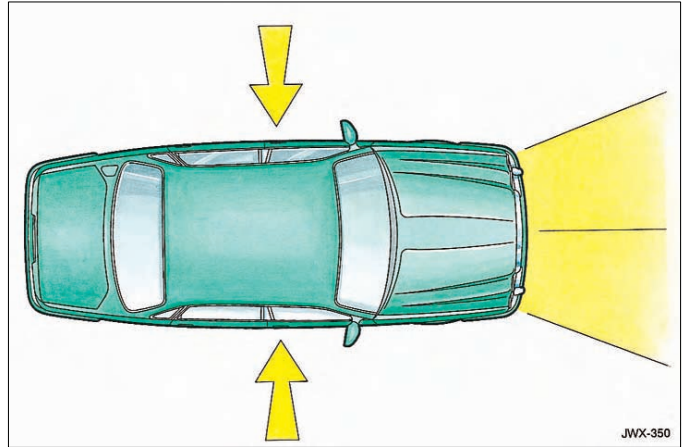

- 3. Driver and front seat passenger should always move their seats back as far as is practical.**
- 4. To ensure that the side airbags are fully effective:**
DO NOT sit too close to the door trim.
DO NOT lean against the door trim.
DO NOT lean out of the window aperture.
Always use Jaguar approved seat covers as non-recommended covers could effect the performance of the side airbags.

The airbags are designed to inflate in severe frontal and side impacts that occur within the shaded area and in the direction of the arrows as shown above. They will not deploy at very low speeds or in rear impacts.

An alert label on the front face of the driver's and passenger's sunvisor directs you to read the warning label on the rear face of each sunvisor. The warning label contains the following statement:



DEATH OR SERIOUS INJURY CAN OCCUR

Children 12 and under can be killed by the airbag.

The **BACK SEAT** is the **SAFEST** place for children.

NEVER put a rear-facing child seat in the front.

Sit as far back as possible from the airbag.

ALWAYS use **SEAT BELTS** and **CHILD RESTRAINTS**.

The airbags are electrically activated and self contained within the steering wheel hub, the fascia panel and the sides of the front seats. The whole sequence of events from sensing the impact to full inflation of the bag takes place in a fraction of a second.

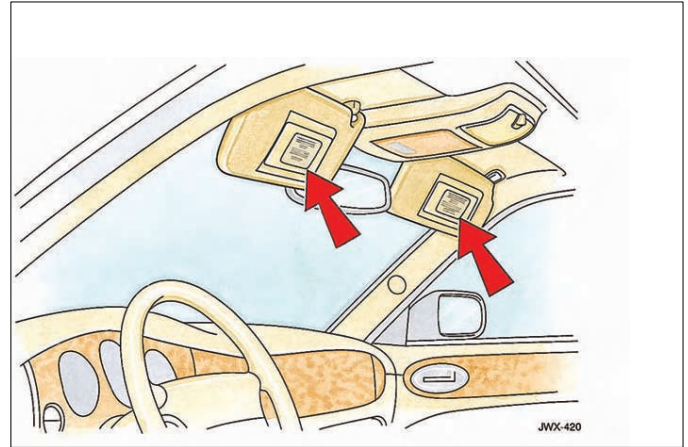

With the driver's and front passenger's airbag the occupant restrained by the seat belt moves forward, the head and chest come into contact with the inflated bag which then deflates in a controlled manner, via vent holes to absorb the remaining energy of the impact.

Similarly, with the side airbags, the airbag inflates upon side impact and breaks through the seat bolster stitching, protecting the side of the rib cage of the driver or front seat passenger.

The noise and gas associated with the deployment of the airbags is not injurious to health.

In circumstances where the airbags are not deployed, protection is provided by the seat belts. The severity of the collision is a function of the relative speed and weight of the vehicles or objects colliding.

4-20 Pre-driving

All work on the airbag system, including renewal after deployment and renewal at the end of its service life, must be carried out by an authorised Jaguar Dealer.

In the event of the vehicle being dismantled, airbag module disposal instructions can be obtained from an authorised Jaguar Dealer. Instructions are also reproduced in the Service Manual.

Child Safety



WARNING:

Child seats and passenger airbag:

- 1. Children of 12 years old and under can be killed or seriously injured by the airbag. The rear seat is the safest place for children.**
- 2. DO NOT install a rearward-facing child seat in the front passenger seat position. This is emphasised by the label displayed on the end of the fascia on the front passenger side.**
- 3. If however, you must sit a child in the front passenger seat use only a forward facing child seat with the passenger seat set fully rearward. Always follow the fitting instructions supplied with the appropriate child restraint system.**

In many States and countries legislation governs how and where children should be carried when travelling in a vehicle. It is the responsibility of the driver to comply with all regulations in force in the country where the vehicle is being used.

According to accident statistics, children are safer when properly restrained in the rear seating positions than in the front seating position. **Jaguar strongly** recommends that at all times children are carried in the rear seating positions.

Child Safety (Continued)

Holding a baby or child in a person's arms is not a substitute for a child restraint system.

In an accident a baby or child held in a person's arms can be crushed between the vehicle's interior and a restrained person. The child can also be injured by hitting the interior or by being thrown from the vehicle during a sudden manoeuvre or impact.

Injury can also be caused if the baby or child is allowed to ride on the seat unrestrained. Other occupants should also be properly restrained to help reduce the chance of injuring the child.

Do not allow children to stand in the space between the front seats or on the rear seats.

Children must be restrained by the use of a child safety restraint applicable to their weight and size.

A range of safety restraint devices are available as Jaguar Accessories; consult your Jaguar Dealer for details.

Fitting and instructions for use are included in each kit and must be followed explicitly to ensure proper use.



WARNING:

- 1. Do not try to put an adult seat belt around two children.**
- 2. Choose a child seat that sits securely on the seat cushion and against the seat back.**

Front and Rear Passenger Seat Belt - Static Reel (Child Seat) Mode.

The passenger seat belts have two operating modes:

1. Inertia reel mode - for adult passengers.
2. Static reel mode - for children in child seats.

The static reel mode prevents belt payout and thereby does not allow the occupant freedom of torso movement. When the seat belt is attached to a child seat which has its own independent harness, the static mode must be used. For child seats that do not have their own independent harness, refer to the manufacturer's instructions. The seat belt defaults to the inertia reel mode when in the stowed (fully retracted) position.

To activate the static reel (child seat) mode: Pay out the belt to its full extension to engage the ratchet mechanism. With the child seat in the required position insert the belt's tongue into the buckle. Retract the belt back onto the reel; a ratchet operation may be felt as the belt retracts. Continue to pay the belt back onto the reel until it fits snugly around the child seat.

To revert to the inertia reel mode: Press the button on the seat belt buckle to release the tongue and allow the belt to return to the stowed position.

Infants

Babies and small children who cannot sit up by themselves should be carried in an approved baby seat.

4-22 Pre-driving

Child Restraint Tether Anchorages

This vehicle has child restraint tether brackets already fitted. The tether brackets are positioned on the rear parcel shelf at the centre-line of each rear seating position. Slide off the cover and the child restraint can be fitted directly to the bracket, after passing the harness under the head restraint.

Ensure that there is no slack in the webbing and that the restraint fits the child snugly across the rib cage and hips. These are the parts of the body most able to take the force of impact.

The lap strap should pass across the top of the child's thighs, bearing on the pelvis, not the abdominal area.



WARNING:

Child restraint anchorages are designed to withstand only those loads imposed by correctly fitted child restraints. Under no circumstances are they to be used for adult seat belts, harnesses or for attaching other items or equipment to the vehicle.

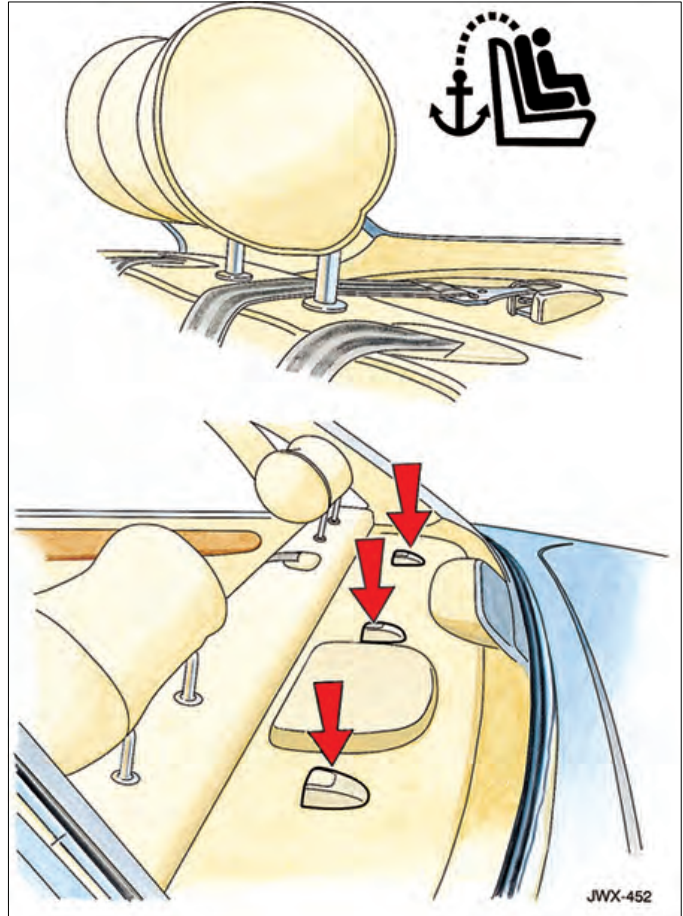

Look for the following when selecting a child restraint system:

- It should have a label certifying that it meets the applicable USA Federal Motor Vehicle Safety Standards (FMVSS) and Canadian Motor Vehicle Safety Standards.
- Carefully read the instructions supplied with the restraint. Be sure you understand them and can install and use the device properly and safely in the vehicle.
- Ensure that the child restraint system is appropriate for the child's weight and development. The label required by the standard or regulations, or instructions for infant restraints, usually provide this information.

Before buying a particular child restraint system, make sure it fits your car and seat belts.

Note: Always ensure that child restraint assemblies are fitted in strict accordance with the child restraint manufacturer's instructions.

Commercially available child seats complying with the legal standard are designed to be secured by lap belts or the lap/shoulder seat belt.

4-24 Pre-driving

Garage Door Opener (GDO)

The garage door opening equipment comprises an electronic module fitted in the vehicle's roof console. This module can be programmed to transmit the radio frequencies of up to three of the owner's current hand-held transmitters, for the operation of garage doors, gates, lighting or security systems, and other radio frequency operated services.

 **WARNING:**

1. This GDO must not be used with installations that do not have a sensor that will automatically 'stop' and 'reverse' a closing garage door if an object is detected in its path.
2. When programming a channel, the system that you are programming will be activated if it is within signal range, therefore, make sure that people or objects are clear of the garage doors or gates being opened or closed.

To programme the GDO's roof console module proceed as follows:

Note: The GDO may not programme to older garage door openers that do not meet current Federal Consumer Safety Standards.

1. Switch off the engine.
2. Decide which of the three channels you wish to train.
3. Hold the end of your hand-held transmitter against the roof console just forward of the four operating buttons.



4. Using both hands, press both the hand-held transmitter button and the selected channel button on the roof console. DO NOT RELEASE EITHER BUTTON until step 5 has been carried out.

5. Hold down both buttons until you see the red light on the roof console flash slowly at first, then rapidly. This could take up to one minute, or more. Release both buttons when the red light flashes rapidly. This rapid flashing indicates that the GDO transmitter has been successfully programmed to match your hand-held transmitter, (if the light flashes yellow it indicates that you have a rolling code GDO, see next column).

The old hand-held transmitter can now be set aside and the roof console button used in future.

Note: (Canada only) During programming, the hand-held transmitter may automatically stop transmitting after one or two seconds, which may not be long enough for the GDO to be programmed. If you believe you have one of these hand-held transmitters you should press and press again the transmitter every two seconds without releasing the GDO channel button. After re-activating your transmitter (operations 4 and 5), the GDO indicator light should flash rapidly indicating successful programming. If it returns to the slow flash, continue the procedure until a successful programming operation is indicated by the rapid flashing signal.

Programme the other channels, as required, using hand-held transmitters previously used for other electronic services.

Training with rolling code (1995 and newer units).

To train a rolling code garage door opener to operate from the integrated transmitter, follow these steps:

1. Programme your portable remote control to the vehicle integrated transmitter as described previously.
2. Remove the cover panel from the GDO receiver. The receiver would be located by the garage door opener motor.
3. Locate the training button on the GDO receiver. The exact location and colour of the button may vary by different manufacturers. If the training button cannot be located, consult the GDO manual.
4. Press the receiver training button for two seconds.
5. Return to the vehicle and press the integrated transmitter button for the duration of the rapid flashing yellow indicator light (one to two seconds). Release the button and then press the button again to confirm that the integrated transmitter has been trained to the receiver.

The garage door opener has now been trained to recognise your vehicle GDO. Either the integrated transmitter or the original portable remote transmitter can now be used to open the garage door.

Operating the GDO

To operate: Simply press the appropriate button on the roof console. The red light on the roof console comes on when the signal is being transmitted.

Note: The effective range of the GDO transmitter may differ from your old hand-held transmitter.

4-26 Pre-driving

Transmitter Programming Trouble-shooting

If the GDO transmitter does not programme to your hand-held transmitter, re-read the instructions carefully and repeat the steps. If still unsuccessful, read the following important details:

- Check that the batteries in the hand-held transmitter are not dead.
- Hold the hand-held transmitter in the precise position shown in the illustration.
- Press and hold the two buttons, without interruption, for the duration of the programming.
- Turn the hand-held transmitter round and re-programme using the opposite end. For the best results use the opposite end to the battery compartment when programming.

If your unit will not programme after repeated attempts, see your nearest Jaguar Dealer.

To erase previously programmed frequencies:

Press and hold the two outermost channel buttons until the red light begins to flash. This will erase all three channels. Individual channels cannot be erased, but can be re-programmed at any time by conducting the programming procedures over again.

This appliance complies with Part 15 of the USA Federal Communications Commission (FCC) rules. Operation is subject to the following two conditions:

1. The devices may not cause harmful interference.
2. The devices must accept any interference received including interference that may cause undesired operation.



WARNING:

The manufacturer is not responsible for any radio or TV interference caused by unauthorised modifications to this equipment. Such modifications could void the user's authority to operate the equipment.

General Driving Information

Before Starting

Before starting the engine, new owners/drivers should familiarize themselves with the layout and operation of the controls and instruments described on preceding pages.



WARNING:

Ensure the handbrake is on and the gear selector is in position 'P' or 'N' before attempting to start the engine.

Attention should be given to items in **Regular Checks**, see SECTION 3 of the Vehicle Care Handbook.

Disengage the steering lock and start the engine.

Before driving off, check the instruments, warning lights and message centre. Take special note of any warning light that is on.

Seat belts are provided for your safety and it is unwise, and in certain countries illegal, to commence any journey, however short, without wearing them.

Warming Up

Do not operate the engine at high rev/min when first started but allow time for the engine to warm up and the oil to circulate. In very cold weather it is advisable to run the engine at 1500 rev/min with the vehicle stationary (in the open air) until a rise in temperature is indicated on the gauge.

Use of Headlamps in Daylight (Except Canada)

When visibility is poor, the headlamps on dipped beam setting must be switched on, so that the vehicle may be seen more easily by other road users.

In conditions of poor daytime visibility, switching the headlamps on manually may be preferable to the use of the Auto headlamp feature.

The instrument illumination control adjusts the brightness of the panel lighting.

Climate Control Solar Sensor

A solar sensor unit is located centrally on top of the fascia. This sensor should not be covered as it is required for climate control sensing.

Emission Control

The emission control systems control the emission of hydrocarbons, carbon monoxide, oxides of nitrogen and fuel by evaporation.

It is essential that routine maintenance operations are carried out by a Jaguar Dealer at the specified intervals.

5-2 Driving

Engine Oil Consumption

A certain amount of oil consumption is normal. The rate of consumption will depend on the following:

- The quality and viscosity of the oil.
- The amount of oxidation and dilution of the oil.
- Climatic conditions.
- The speed at which the engine is being operated.
- Road conditions.

Drivers should expect above normal consumption when the engine is new, and after running-in if high speeds are sustained.

Winter Driving

Freeing a Frozen Door Lock

Caution: Do not apply a proprietary Lock De-icer through the keyhole.

Should the lock become frozen, heat the end of the key before use.

Windscreen Wiper Blade

Before driving away, clear any ice from the windscreen and check that the wiper blade is free.

Frost Precautions

The correct concentration of coolant must be maintained at all times when 'topping up' or 'refilling' the cooling system. See **Checking and Replenishment** in SECTION 3 of the Vehicle Care Handbook.

Winter (Snow) Tyres

The use of winter tyres will considerably improve the vehicle's handling in adverse winter conditions.

Winter tyres must be used in a complete vehicle set, see **Wheel/Tyre Data** in SECTION 6 of the Vehicle Care Handbook for recommended tyres and tyre pressures.

Snow Chains and Spikes Spiders

Snow chains or spike spiders, of the recommended type, may only be fitted to the rear wheels. See SECTION 5 of the Vehicle Care Handbook.

Switch off traction control when using snow chains or spikes spiders.

The maximum speed when using snow chains or spiders is 30 mph (48 km/h).

Remove the snow chains or spikes spiders as soon as the roads are clear of snow.

Running-in

Apart from a few precautionary recommendations, there are no strict 'running-in' procedures for this vehicle.

By observing the following advisory notes you will ensure maximum engine, transmission and brake life for your vehicle.

1. Allow the engine to warm up thoroughly before operating at engine speeds over 3500 rev/min.
2. Vary the speed frequently.
3. From 1000 miles (1500 kilometres) onwards, gradually increase performance of the vehicle up to the permitted maximum speed.

Brakes

The front and rear disc brakes are on separate brake circuits. Should one of the brake circuits fail, the other circuit will still operate. If one circuit fails, brake pedal travel and effort will increase, however, if it is the front circuit which fails, considerably greater travel and effort will be required to stop the vehicle. In any event consult a Jaguar Dealer immediately.

Running-in for Brakes

To ensure that the brake pads can 'bed-in' evenly and reach their optimum wear and performance condition, the following points are recommended.

1. Where possible, avoid heavy braking or rough usage of the brakes as this can result in damage being caused to the brake pads and discs.
2. Avoid prolonged use of the brakes, for example, when descending severe gradients.
3. Frequent light application of the brakes is desirable. This helps to fully 'bed-in' the brake pads before the normal running-in period is completed and the vehicle is operated at high speeds, when maximum brake efficiency will be required.

The above equally applies when new discs or pads have been fitted.

Anti-lock Braking System (ABS *plus*)

This system helps to prevent the road wheels from locking and skidding during emergency braking, assisting the driver to maintain full steering and directional stability. The factor controlling ultimate stopping distance and cornering ability is tyre/road adhesion.

ABS *plus* optimises tyre/road adhesion under maximum braking conditions though it cannot provide increased cornering ability. There is no need for special braking techniques, such as 'pumping' the brakes, to achieve optimum braking distances and control on poor or slippery road surfaces. Tyres must be in good condition to achieve maximum adhesion.

During normal braking the ABS will not be activated. However, if the braking force applied begins to exceed tyre/road adhesion the ABS will automatically activate, preventing the road wheels from locking. In these circumstances a pulsating effect will be felt from the brake pedal indicating that the system is functioning. The pulsating effect is due to small fluctuations in pressure supplied to the brakes by the system to maintain full tyre/road adhesion.

ABS *plus* recognises differences in speed between the four road wheels caused by slip angle and changes in load whether a vehicle is getting into a critical driving situation on bends, on a surface with varying grip or with abrupt steering movements which confront the driver with understeer or oversteer tendencies. ABS *plus* improves dynamic stability by reducing or increasing brake pressure to individual wheels resulting in better directional stabilisation.

Under severe braking on some road surfaces tyre noise may be apparent even though the wheels will at no time become locked.

5-4 Driving



WARNING:

1. It remains the drivers responsibility to drive safely according to prevailing conditions.
2. The fact that a vehicle is fitted with ABS must never allow the driver to be tempted into taking risks which could affect his/her safety or that of other road users.
3. The addition of ABS cannot overcome the consequences of trying to stop in too short a distance, cornering at too high a speed, or the risk of aquaplaning.
4. The driver should always take road conditions into account. A slippery road surface always requires more braking distance for a given speed, even with ABS. A possible increase in stopping distance compared to locked wheels may occur during ABS operation on slushy snow, gravel, sand, or some heavily corrugated or ridged warning sections of road surfaces.

ABS Monitoring

The ABS control module monitors the ABS electrical system from ignition switch ON to ignition switch OFF. Any malfunction will be indicated by the anti-lock warning light coming on.

Should a fault develop in the ABS system, the brake system will still operate conventionally and with the same standard of performance as vehicles not equipped with ABS.

Caution: Should the warning light come on while driving, a system failure is indicated, consult a Jaguar Dealer immediately.

Advice On ABS Braking Techniques

For optimum ABS performance the instructions on braking techniques during ABS operation should be followed:

1. Do not release brake pressure when the pulsating effect is felt. Maintain a constant pressure until the manoeuvre is completed.
2. To familiarise yourself with the feel of the brake pedal during ABS braking, practise an emergency stop procedure, always making sure it is safe to do so. With the seat belts fitted to all occupants, drive the vehicle at 32 km/h (20 mph) and brake sharply.
3. ABS enables the driver to steer around obstacles during emergency braking. However, the consequences of turning sharply at high speed cannot be overcome by the ABS. Read the warnings listed on this page.
4. Do not attempt to 'pump' the brakes to avoid skidding as this can interfere with the ABS operation. The ABS will not allow the wheels to skid under normal road conditions.
5. The ABS will tend to keep the vehicle straight during braking. Because braking distances may increase under certain road conditions, it is necessary to plan and make turning manoeuvres as early as possible.

Touring

Foreign Travel

Before planning foreign travel, check with a motoring organisation to ensure that your vehicle will comply with legal requirements of the countries you intend to visit.

It is advisable to carry vital spare parts to ensure against a breakdown in a remote area.

Touring kits (available in United Kingdom) containing a selection of basic items are available from the Jaguar accessory range.

International motoring organisations are helpful for all aspects of long distance touring advice.

In some countries it is a requirement to carry spare vehicle bulbs.

First Aid Kit

A first aid kit is compulsory equipment in certain countries. Your Jaguar Dealer can supply a first aid kit.

Fire Extinguishers

Many countries make it compulsory to carry a fire extinguisher. Your Jaguar dealer can supply and fit one.

Gasoline in Containers

Some countries forbid the carrying of petrol in containers, as do most ferry and hovercraft operators.

Cellular Radio Telephones in Tourist's Vehicles Abroad

Ask your motoring organisation about the use of cellular radio telephones before travelling abroad, as some countries exercise controls on the importation and use of such equipment.

Jaguar Warning Triangle

A warning triangle to give following traffic advanced notice of a disabled vehicle is compulsory in many countries. A triangle, designed to international standards, is standard equipment in certain markets.

Hazard warning lights must be used with the warning triangle.

The warning triangle with its stand legs folded flat, is mounted on the inside of the luggage compartment lid.

In an emergency, remove the triangle and unfold its stand legs. Place it in the road 18 metres (60 ft) behind the immobilised vehicle to give traffic warning of a potential hazard.

Roof-rack

Only the Jaguar roof-rack should be used. The roof load including the rack must not exceed the specified maximum. The combined roof and luggage compartment loads must not exceed the specified maximum luggage compartment load.

See **Roof-Rack Capacity and Trailer Weights (all Models)** in SECTION 6 of the Vehicle Care Handbook. Loads on the roof-rack may affect vehicle handling, especially in crosswinds or when cornering.

5-6 Driving

Towing a Caravan or Trailer

Your Jaguar Dealer, and the main motoring and caravanning organisations, can advise you on towing, towing weight capacities and about regulations that apply in other countries.

The following contain important points on safety, stability and comfort, on which further advice should be sought. The weights and loads referred to will be found in SECTION 6 of the Vehicle Care Handbook.

- The maximum recommended braked trailer weight is only permissible provided long periods of uphill driving on gradients steeper than 8% is not undertaken.
- Check the kerbside weight of the vehicle.
- When towing, the noseweight of the caravan or trailer and the tow-bar assembly must be deducted from the appropriate maximum trailer weight.
- When towing at the maximum permissible rear axle load, the speed must not exceed 62 mph (100 km/h), and the tyre pressures must be increased to 39 lbf/in² (2,5 bar).
- The maximum recommended tow-ball noseweight must not be exceeded.
- It is essential that only a Jaguar tow-bar and Jaguar electrical tow-bar kit are supplied and fitted by a Jaguar dealer.

Caution: The use of non-Jaguar tow-bar kits may result in damage to vehicle systems.

- Catalytic converters increase exhaust system temperatures (particularly under engine malfunction). Do not drive or park over combustible materials such as dry grass or leaves which may come into contact with the exhaust system.
- Avoid heavy braking. Since the overrun brake on the caravan or trailer is not connected to the ABS, heavy caravan or trailer braking could critically affect the stability of the outfit as a whole.
- Ensure that the towing vehicle's engine, transmission, suspension, brakes and tyres are fully efficient and regularly serviced. Similarly check the wheels, tyres, brakes and wheel bearings of the caravan or trailer.

Introduction

The climate control system fitted to this vehicle offers automatic control of temperature, fan speed and air distribution to maintain optimum comfort under most driving conditions.

Manual controls are provided to allow the driver to override the automatic operation.

Control Panel

1. a) Push to switch ON or OFF.
b) Rotate for manual fan speed selection.
2. Manual recirculation/outside air.
3. Centigrade/Fahrenheit selection buttons.
4. Display panel.
5. External temperature.
6. Air conditioning.
7. Automatic operation.
8. Manual distribution:
 - a) Face only.
 - b) Bi-level (Face and feet).
 - c) Feet only.
 - d) Demist (Screen and feet).
9. Temperature selection:
Blue – Decrease.
Red – Increase.
10. Heated rear screen.
11. Heated front screen (where fitted).
12. Defrost.

General Information

Ensure that the air inlet grille at the base of the front windscreen is clear of leaves, snow or other obstructions.

A solar sensor unit is mounted on the top of the fascia, this should not be covered when driving.

The intake grille of the in-car temperature sensor is located on the lower fascia, driver's side. To ensure optimum temperature control this grille should not be obstructed.

Condensate which forms at the evaporator in the air conditioning unit is discharged onto the road underneath the vehicle. After stopping, puddles of water will form underneath the vehicle.

The refrigeration system (A/C button) should be run briefly at least once a week to lubricate the compressor seal and prevent refrigerant leakage.

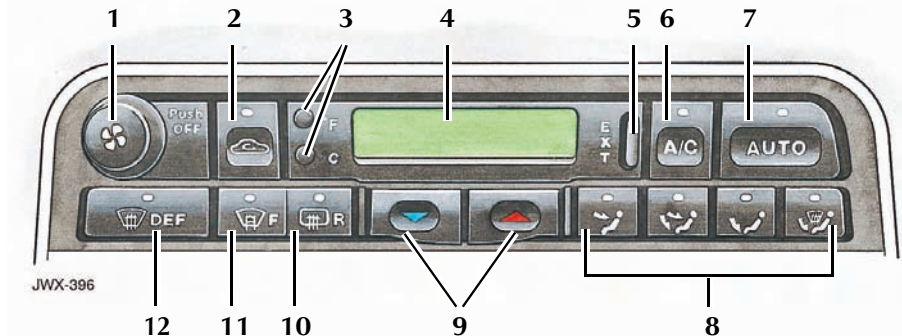

6-2 Climate control

System Operation and Button Functions

Switching the System On

The system can be switched on by pressing one of the following:

1. 'AUTO' button – Switches the system on in automatic mode.
2. 'DEF' button – Switches the system on in defrost mode.
3. 'A/C' button – Switches the system on in the last setting and with the refrigeration system working.
4. 'Push Off' knob – Switches the system on in the last setting.

Automatic Operation

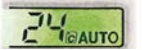

Note: The fans will not operate until the engine is warm (except in defrost).

Press 'AUTO' for optimum automatic control under most operating conditions. The word 'AUTO' will appear in the display panel and the temperature, fan speed and distribution will be controlled automatically.

Air Conditioning



Press to switch off the refrigeration system. Press again to switch on. The refrigeration system is automatically engaged when 'AUTO' is selected.

All the year use of air conditioning is recommended for optimum comfort and to reduce interior misting.

Temperature Selection



The selected interior temperature is shown in the display panel. Press the 'red' button to increase the temperature. Press the 'blue' button to decrease the temperature.

Automatic temperature control operates between 61° F and 90° F (17° C and 31° C). In addition, 'HI' and 'LO' settings provide maximum heating or cooling at maximum fan speed. Fan speed can be manually reduced as required.

Defrost



Press 'DEF' to direct air to the front and side screens at maximum fan speed. This also switches on the heated front screen (if fitted). Fan speed can be manually reduced as required. Press 'DEF' again to return to the last setting or 'AUTO' for automatic control.



WARNING:

Directing cold air onto the screen in warm humid conditions can produce external condensation.

Manual Air Recirculation



Closes the outside air intakes and recirculates air within the vehicle. Prevents unpleasant odours being drawn into the vehicle.

Two options of control are available:

1. Press the button to provide recirculation of interior air for a period of approximately five minutes.
2. Press and hold the button until two 'beeps' are heard to provide continuous recirculation of interior air. Press the button again to switch off.



WARNING:

Avoid using Manual Air Recirculation for prolonged periods in cold weather as this may result in interior misting of screens.

Heated Front Screen (where fitted)



With the engine running, press to switch on the heated front screen for rapid defrost/demist. It is automatically engaged when 'DEF' is selected but can be independently switched on or off at any time. Automatically switches off after approximately six minutes.

Heated Rear Screen



With the engine running, press to switch on the heated rear screen and heated door mirrors for rapid defrost/demist. It can be independently switched on or off at any time. Automatically switches off after approximately 20 minutes.

Manual Fan Speed

Note: In 'AUTO' the fans will not operate until the engine is warm.



Turn the rotary knob clockwise to increase or anti-clockwise to decrease air flow. Fan speed is displayed as a series of bars, and the word 'AUTO' will disappear.

Press 'AUTO' to resume automatic control.



Centigrade/Fahrenheit Selection



Press '°F' to display temperature in Fahrenheit.

Press '°C' to display in Centigrade.

6-4 Climate control

Manual Air Distribution

The following options are available:



Face only



Bi-level (face and feet)



Feet only



Demist (Screen and feet)



WARNING:

Directing cold air onto the screen in warm humid conditions can produce external condensation.

Press the required button (the word 'AUTO' will disappear from the display panel). Press the button again or press 'AUTO' to resume automatic control.

External Temperature



Two options are available for displaying the external temperature:

1. Press the button to provide a display for approximately 4 seconds.
2. Press and hold the button until two 'beeps' are heard to provide a continuous display of external temperature. Press the button again to switch off.

Switching Off/Ventilation Airflow



Press the 'Off' knob to switch off the climate control system and prevent outside air from entering the vehicle.

If ventilation is required with the system off, press the desired manual air distribution button. This will provide unconditioned air only when the vehicle is moving.

Note: Heated screen and external temperature display functions can be selected when the system is off.

Operating Tips

Hot Weather Operating Tips

If the vehicle has been parked in the sun the interior will cool faster if you follow these guidelines:

- Before sitting in the vehicle, leave door(s) open for a short time to allow the hot air to escape.
- Drive for a short time with the windows open to force the hot air out of the vehicle.

Cold Weather Operating Tips



WARNING:

To prevent humidity build up inside the vehicle and possible screen misting, avoid driving with the system off or in manual air recirculation for prolonged periods.

Air Distribution

The illustration on the next page shows the location of the air vents within the vehicle.

Air distribution is automatically controlled when 'AUTO' is selected. Manual control can be achieved using the air distribution buttons.

Airflow from the fascia vents can be regulated or switched off using the thumbwheel controls on those vents. The airflow through these vents may be directed by adjusting the vanes.

System Fault Display

The climate control system is equipped with self diagnostics.

If a fault is detected, the symbol 'Er' will appear in the display accompanied by a series of beeps for 5 seconds. In this unlikely event the vehicle should be returned to the Jaguar Dealer at the earliest convenience.

'Er' will be displayed on each subsequent vehicle start until the fault is rectified.

6-6 Climate control

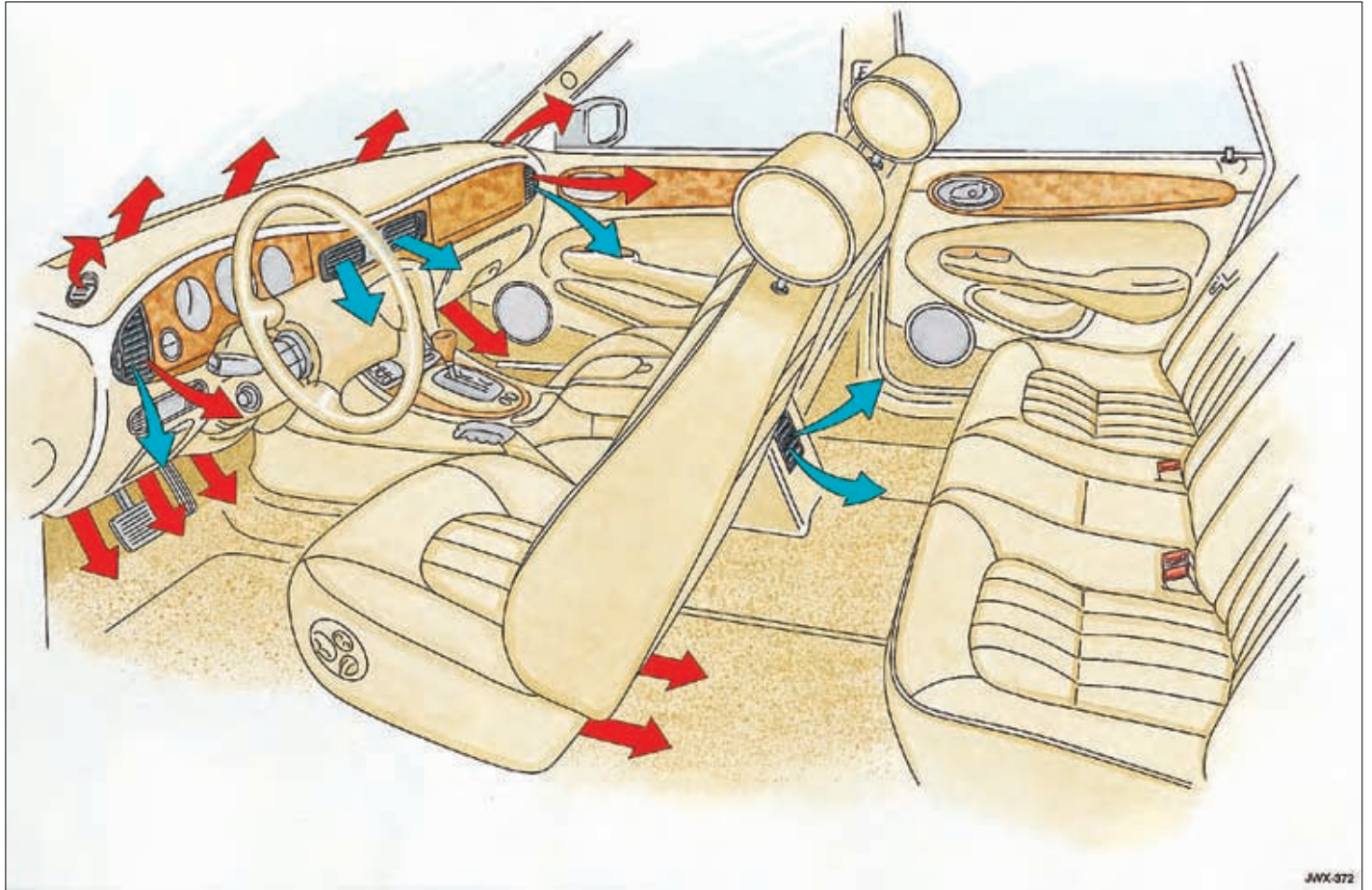

Ashtrays and Cigar Lighters

The ashtray and cigar lighter for the driver and front seat passenger is situated in front of the centre console armrest.

A cigar lighter is provided for rear seat passengers in the rear of the centre console.

Ashtrays for the rear compartment are situated in each rear door armrest.

To open the centre console ashtray: Press the front edge of the lid which will open to reveal the cigar lighter and removable tray.

To operate the cigar lighter: With the ignition in position 'I' press down and wait until the element has heated, it will then 'pop-up'.

Note: Never hold the lighter knob down. Do not attempt to remove particles from the element, as it is self cleaning.

To empty the ashtrays: Lift out vertically and remove.

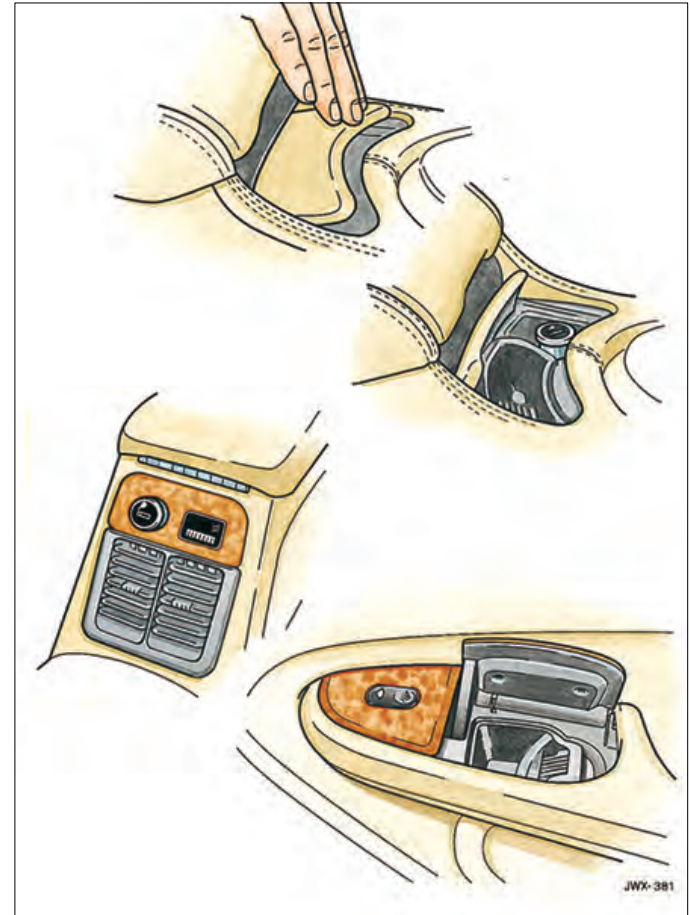

7-2 Driving

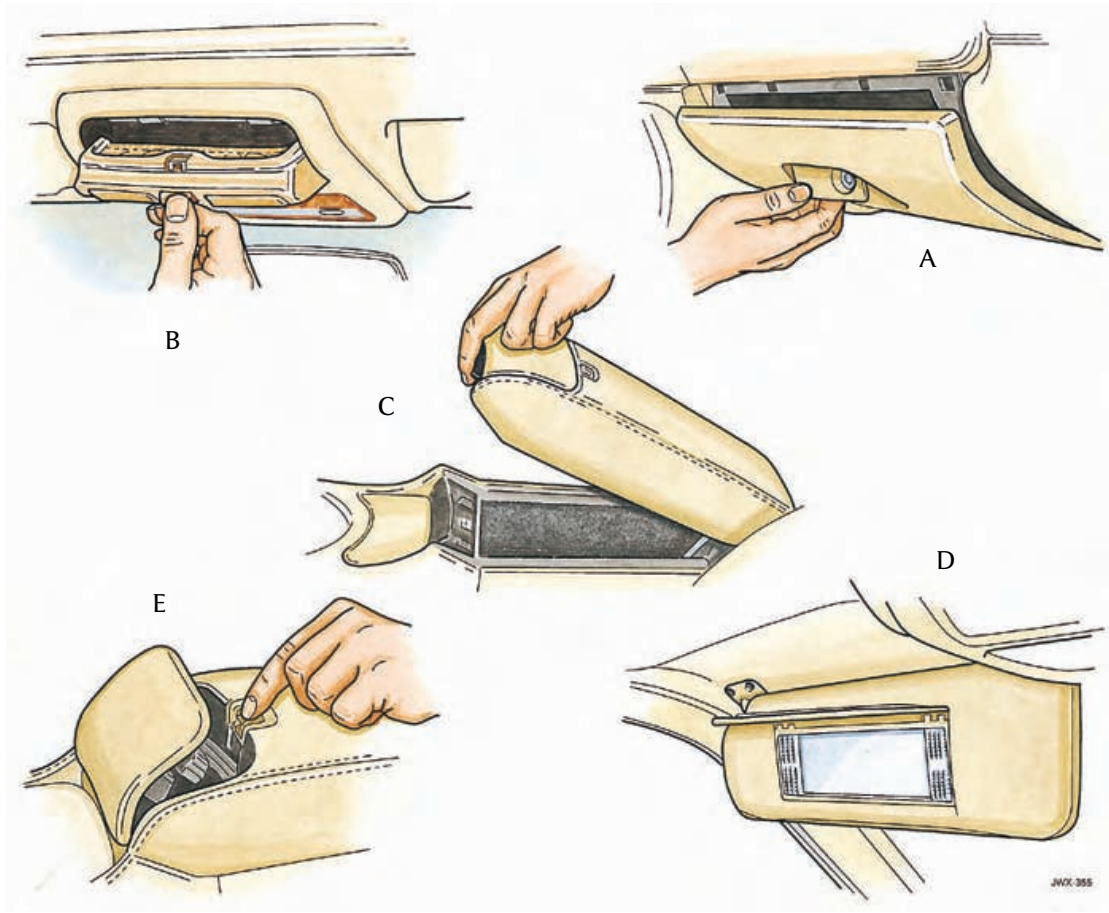

Glove Compartment

A glove compartment (A) is situated below the passenger's airbag. This compartment may be locked using the black-headed key only.

To open: Lift the handle and allow the lid to drop down. The compartment will be illuminated when open.

Note: The compartment will illuminate for up to 15 minutes after the ignition has been switched to position '0'.

Stowage is provided for: the Driver's Handbook Literature Pack, pen holder and a rechargeable torch (available as an accessory).

Sun-glasses Stowage Compartment

Press the button on the roof console and the stowage compartment (B) will open.

Place the sun-glasses into the pocket and close the stowage compartment.

Centre Console Armrest

The armrest (C) is hinged at the rear to provide access to a storage compartment, and incorporates a cupholder (where fitted) which is described below.

On vehicles fitted with the optional GSM telephone, the storage compartment is fully occupied by the handset and vehicle interface.

Sun Visors and Vanity Mirrors

Adjustable sun visors (D) can be swung downwards or unclipped and swung sideways to eliminate sun glare.

The rear of each sun visor is fitted with an illuminated vanity mirror, behind a hinged flap. The light comes ON when the flap is lifted.

Cupholder (where fitted)

A cupholder (E) for two cups is provided in the centre console armrest.

To operate: Push the button on the armrest rearwards. After use, lower the cupholder flap and press down to engage the latch.

Do not use the cupholder while the vehicle is moving. **Do not** open the storage compartment while the cupholder is being used.

7-4 Driving

Picnic Trays (where fitted)

Picnic trays are fitted in the rear of the front seat backs. Open by holding the bottom edge with both hands and pulling out and upwards. When fully up, turn the tray to the horizontal position. Reverse the above procedure to fold the tray away.

Do not use picnic trays in a moving vehicle. Stow away securely.

Rear Centre Armrest

Pull the loop firmly on the rear centre armrest to lower. If not required, raise the armrest to its upright position and push firmly home.

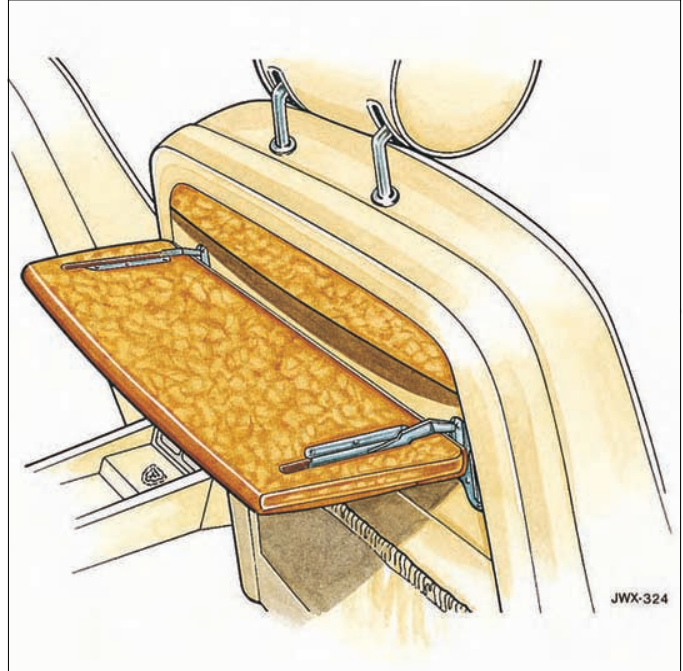

Sunroof (where fitted)

The sunroof switch is in the roof console. This switch will only operate when the ignition switch is in position 'I' or 'II'.



WARNING:

Before opening or closing the sunroof check that all occupants are kept clear.

To open: Touch the rear of the switch and the sunroof will open fully. It can be stopped in any position by a further touch on any part of the switch.

To open to any position: Press and hold the rear of the switch until the required open position is reached, then release the switch.

To close: Touch the front of the switch and the sunroof will close fully. It can be stopped in any position by a further touch on any part of the switch.

To close to any position: Press and hold the front of the switch until the required position is reached, then release the switch.

To tilt open: Press and hold the front of the switch.

To close from tilted: Press and hold the rear of the switch.

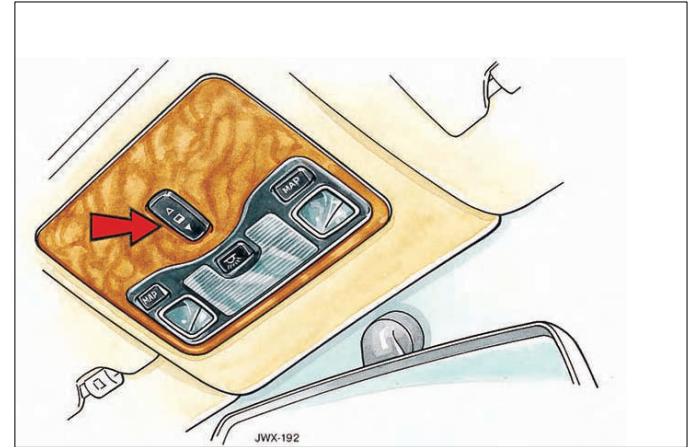

8-2 Exterior features

Sunroof – Manual Operation

If the powered operation fails, the sunroof can be opened or closed by hand.

Remove the roof console to gain access to the sunroof drive spindle as follows:

Press the button on the roof console to open the sun-glasses stowage compartment.

Turn the fastener located in the sun-glasses compartment 90° anti-clockwise. Lower the roof console rear end slightly and withdraw it rearwards. Unplug the connector and place the console on a soft, clean surface.

Insert a wide blade screwdriver into the slot in the motor spindle and turn clockwise to open or anti-clockwise to close the sunroof.

Note: After the cause of motor power failure has been found and rectified, re-engage the motor by turning the spindle a quarter turn anti-clockwise if sunroof is open, or clockwise if sunroof is closed.

Reconnect the roof console connector and refit the console, with the front end first, then locate the rear and secure with the fastener.

Close the sun-glasses compartment.

