



S-TYPE

DATE 06/05

S307-19

SERVICE

## TECHNICAL BULLETIN

5-Speed Transmission – Erratic or Harsh Shifts – Valve Body Kit Available – Repair Procedure

MODEL 2000-02 MY  
S-TYPE

VIN L00001-M44997

### Issue:

Some 2000-02 MY S-TYPE vehicles within the above VIN range may exhibit erratic or harsh transmission shifts. This can be caused by valve body or control solenoid failure.

### Action:

**Note:** Check for connector/wiring and Powertrain Control Module (PCM) faults, ensure the transmission fluid is clean and there is no debris in the sump. Refer to Global Technical Reference GTR Workshop Manual, section: 307-01 - Diagnosis and Testing. Any faults other than the valve body kit replacement, are to be carried out as a separate Warranty Claim.

When a fault has been confirmed with the valve body or control solenoid, a new valve body kit must be installed. Follow the Service Instruction outlined below.

1. Open driver door.
2. Switch ignition 'ON'.
3. Apply footbrake, move selector lever to the neutral position and release the footbrake.
4. Switch ignition 'OFF'.
5. Close driver door.
6. Disconnect battery (see Global Technical Reference GTR Workshop Manual, section: 414-01).

**NOTE: THE INFORMATION IN TECHNICAL BULLETINS IS INTENDED FOR USE BY TRAINED, PROFESSIONAL TECHNICIANS WITH THE KNOWLEDGE, TOOLS, AND EQUIPMENT TO DO THE JOB PROPERLY AND SAFELY. IT INFORMS THESE TECHNICIANS OF CONDITIONS THAT MAY OCCUR ON SOME VEHICLES, OR PROVIDES INFORMATION THAT COULD ASSIST IN PROPER VEHICLE SERVICE. THE PROCEDURES SHOULD NOT BE PERFORMED BY "DO-IT-YOURSELFERS." DO NOT ASSUME THAT A CONDITION DESCRIBED AFFECTS YOUR CAR. CONTACT A JAGUAR DEALER TO DETERMINE WHETHER THE BULLETIN APPLIES TO YOUR VEHICLE.**

7. Raise vehicle on lift and place a suitable drain pan under the transmission.
8. Undo and remove the transmission drain plug and discard the seal.
9. Allow the transmission fluid to drain.

**Note:** Ensure the transmission fluid is clean and there is no debris. If this is not the case, stop and do not perform this bulletin procedure.

10. Install a new fibre washer and install and tighten the drain plug.
11. Align transmission jack under transmission.
12. Place suitable supporting blocks onto the transmission jack and raise to support the transmission.
13. Remove the transmission rear mounting securing bolts.

**⚠ Caution:** Do not allow the engine to contact the bulkhead.

14. Lower the transmission jack.

Working with an assistant:

15. Raise rear of the transmission by hand and reposition the jack to support the transmission between the sump and rear of transmission main casing (Illustration 1).

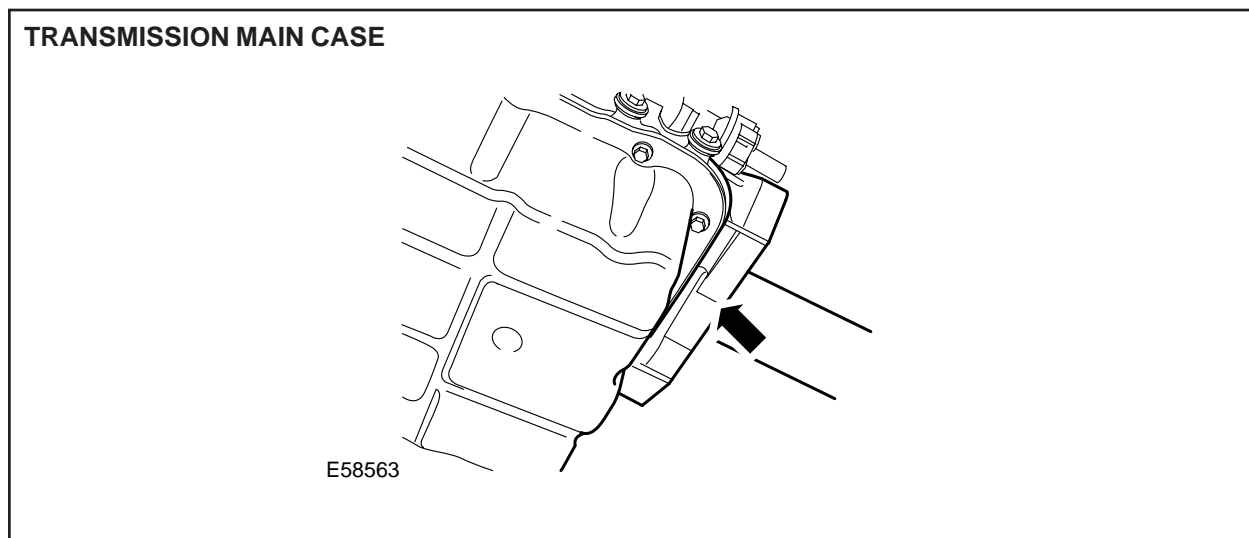

ILLUSTRATION 1

Working alone:

16. Disconnect the Transmission Range (TR) sensor electrical connector.
17. Remove the TR sensor securing screws, and displace and remove the TR sensor from the transmission (Illustration 2).

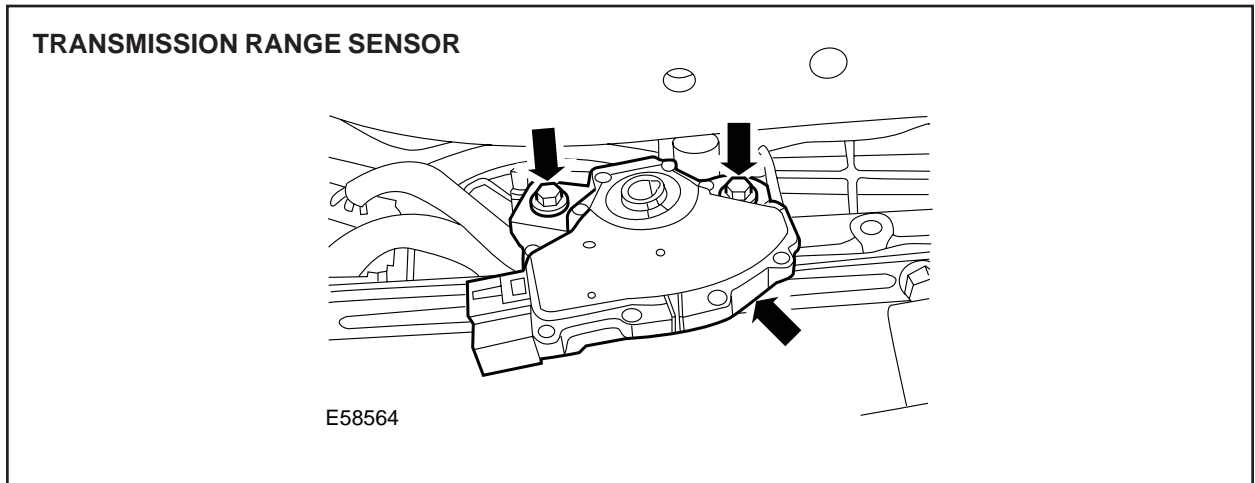

ILLUSTRATION 2

**⚠ Caution:** Ensure the transmission fluid is clean and there is no debris in the sump.

18. Remove transmission fluid pan, gasket and filter (see Global Technical Reference GTR Workshop Manual, section: 307-01).
19. Disconnect the solenoid block electrical connector (Illustration 3).

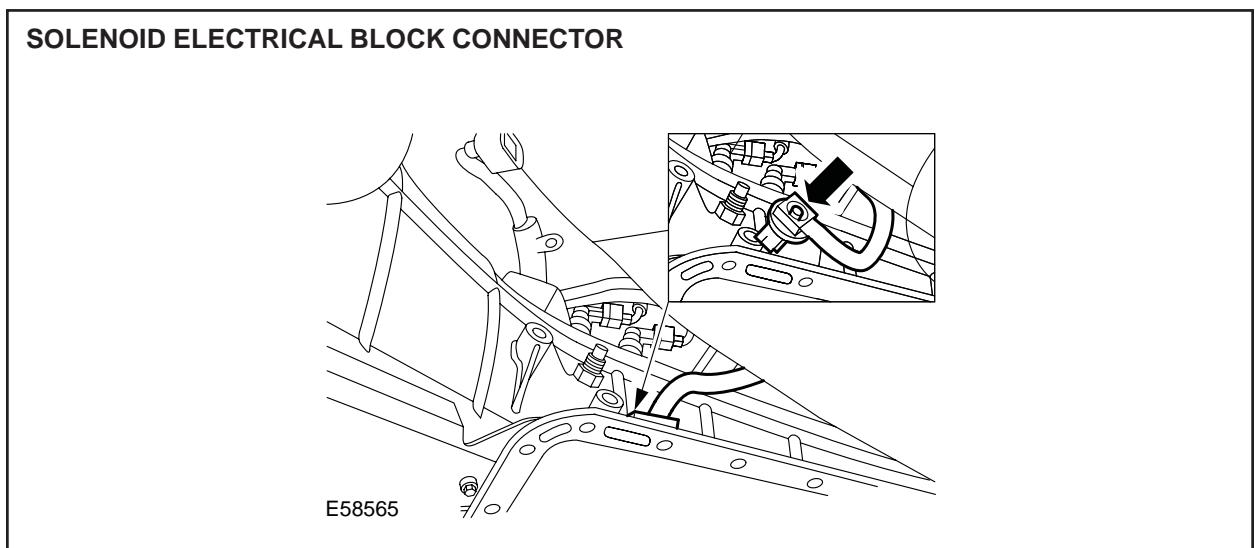

ILLUSTRATION 3

20. Disconnect the pressure switch electrical connector (Illustration 4).

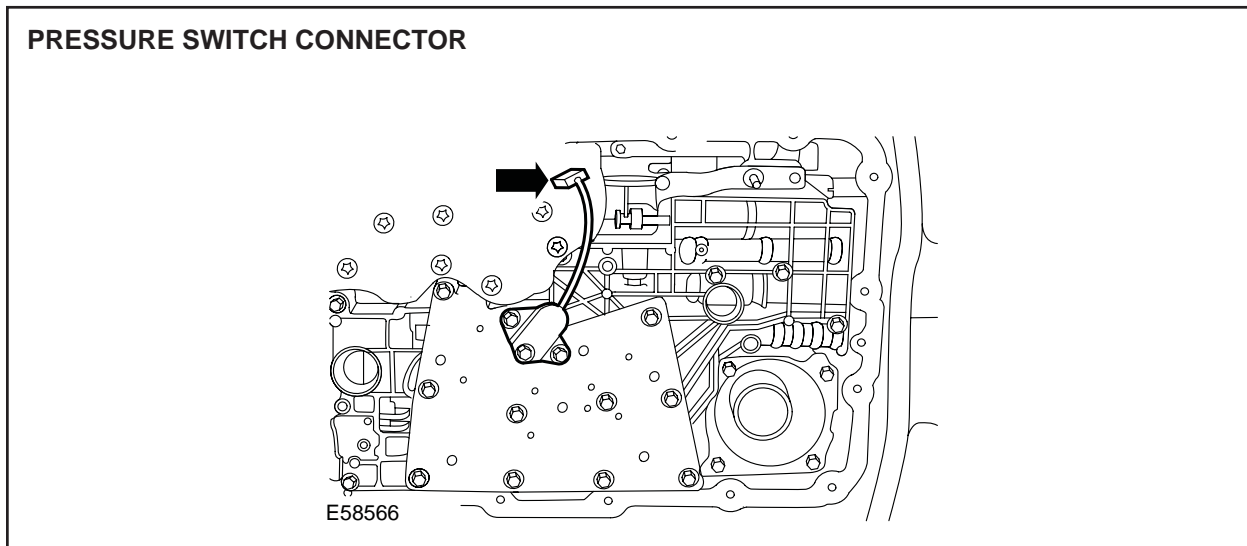

ILLUSTRATION 4

21. Remove the pressure switch securing bolts. Remove the pressure switch.
22. Remove the solenoid block securing bolts and remove solenoid block. Remove and discard the O-rings (Illustration 5).

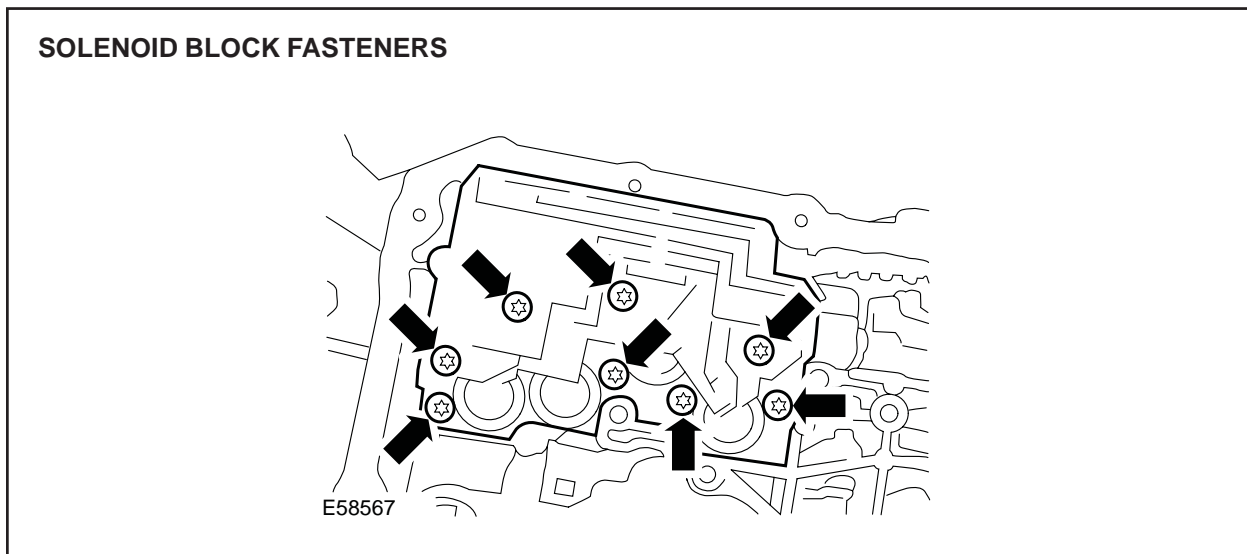

ILLUSTRATION 5

23. Remove the main control valve body (see Global Technical Reference GTR Workshop Manual, section: 307-01 - 44.40.01 - Removal - Carry out steps 12 to 17).

24. Install the new main control valve body (see Global Technical Reference GTR Workshop Manual, section: 307-01 - 44.40.01 - Installation - Carry out steps 1 to 11).
25. Remove the exhaust system (see Global Technical Reference GTR Workshop Manual, section: 309-00).
26. Remove the heat shield securing bolts, and remove the driveshaft heat shield (Illustration 6).

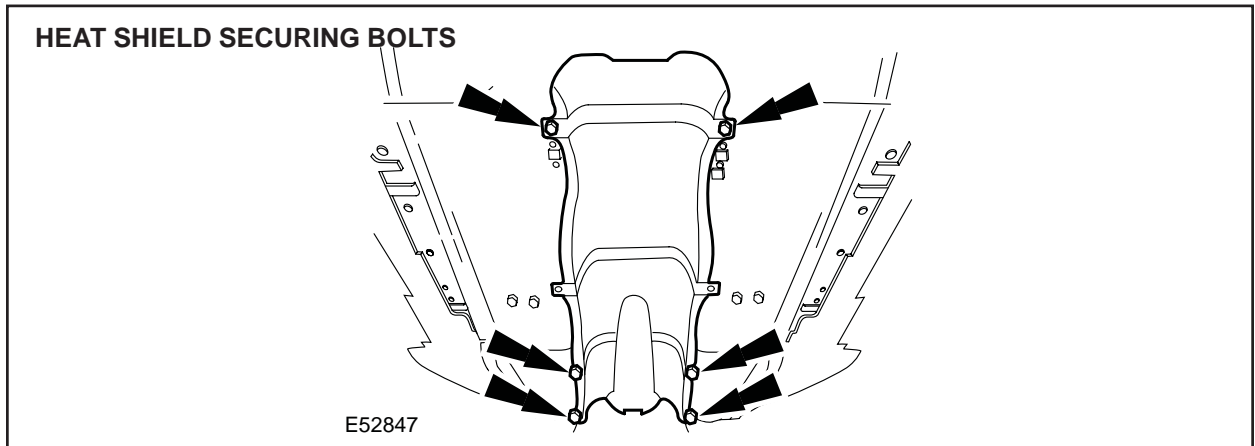

ILLUSTRATION 6

**⚠ Caution:** Make sure the front of the driveshaft does not put an excessive load on the centre bearing. Failure to follow this instruction may result in damage to the vehicle.

**Note:** Mark the position of the driveshaft in relation to the transmission flange. Mark the position of each nut and bolt in relation to the transmission flexible joint.

27. Remove the driveshaft securing bolts, detach the driveshaft from the transmission flange.
28. Using a suitable securing strap, reposition and support the driveshaft to the vehicle body (Illustration 7).

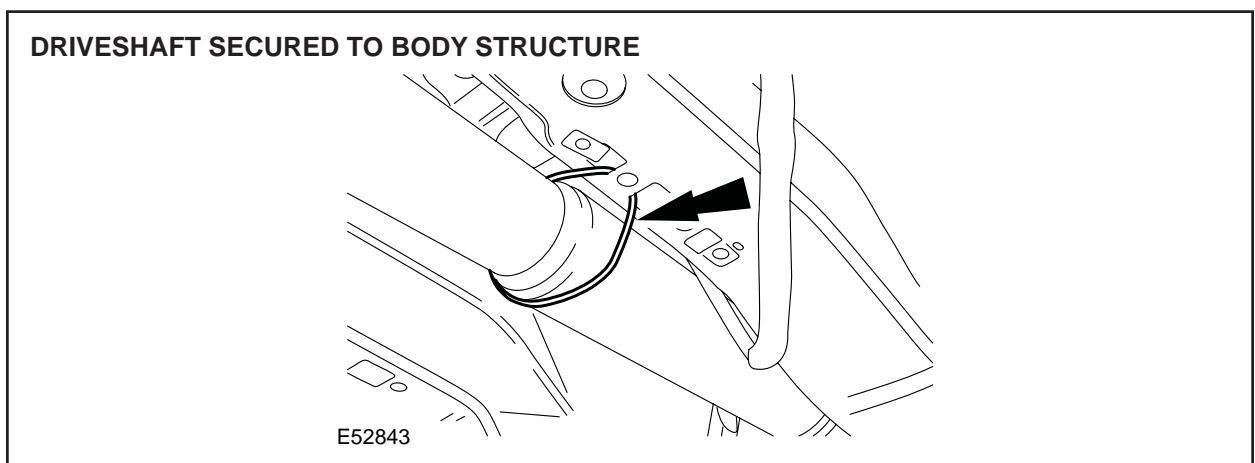

ILLUSTRATION 7

29. Install new transmission fluid filter and gasket, and install the fluid pan (see Global Technical Reference GTR Workshop Manual, section: 307-01).
30. Ensure the manual control lever is in the neutral position.
31. Install the new TR sensor to the manual control lever, install but do not fully tighten the TR sensor securing screws.
32. Align marks on the TR sensor (Illustration 8).

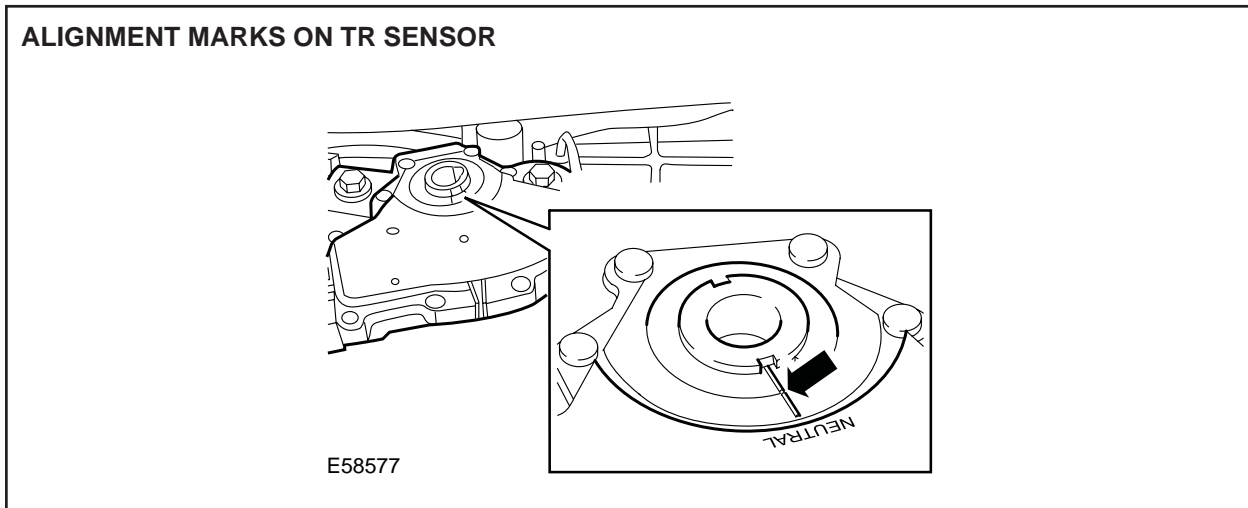

ILLUSTRATION 8

33. Final tighten the TR sensor securing screws to 10 Nm.
34. Connect the TR sensor electrical connector.
35. Disconnect the Intermediate Shaft Speed (ISS) sensor electrical connector (Illustration 9).

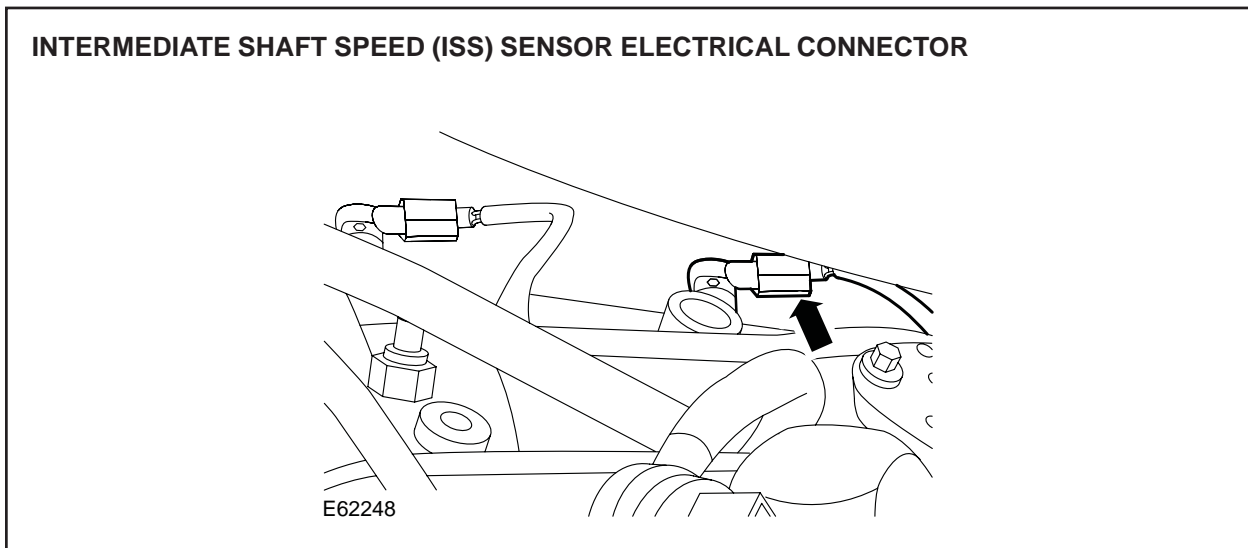

ILLUSTRATION 9

36. Remove the ISS sensor securing screw, and remove the ISS sensor.
37. Install the new ISS sensor; install and tighten the securing screw to 10 Nm.
38. Disconnect the Output Shaft Speed (OSS) sensor electrical connector (Illustration 10).

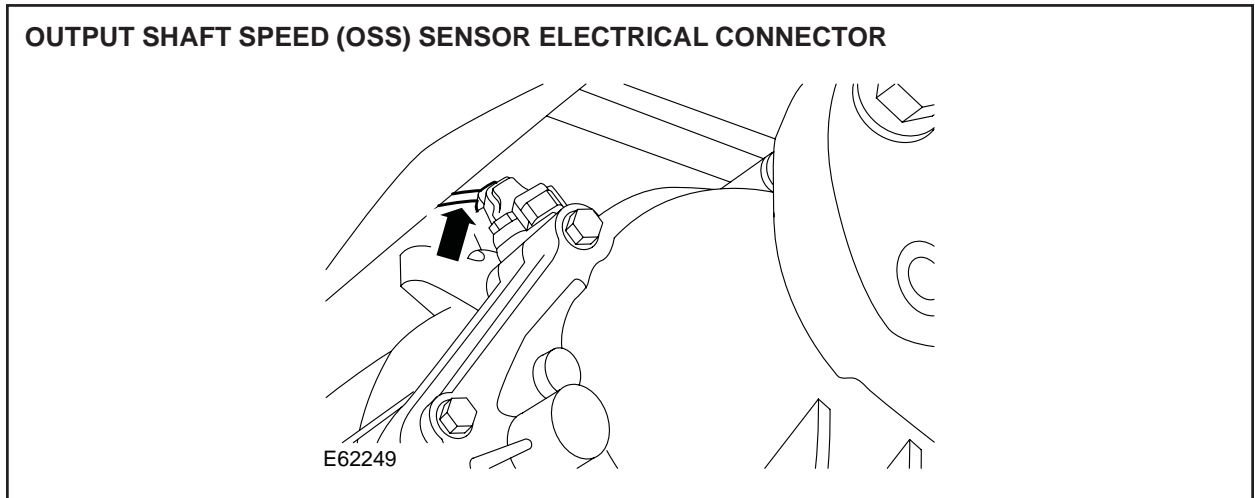

ILLUSTRATION 10

39. Remove the OSS sensor securing screw, and remove the OSS sensor.
40. Install the new OSS sensor; install and tighten the securing screw to 10 Nm.
41. Disconnect the Turbine Shaft Speed (TSS) sensor electrical connector (Illustration 11).

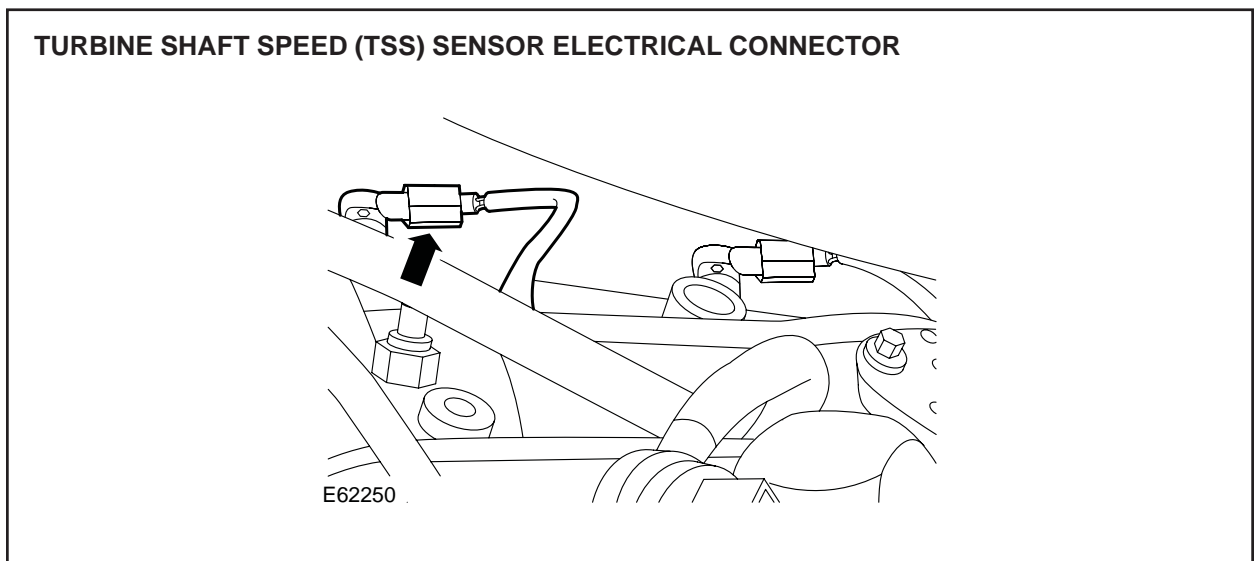

ILLUSTRATION 11

42. Remove the TSS sensor securing screw, and remove the TSS sensor.
43. Install the new TSS sensor; install and tighten the securing screw to 10 Nm.

Working with an assistant:

44. Raise rear of the transmission by hand and reposition the jack under the transmission fluid pan.

Working alone:

45. Raise transmission jack to align the transmission to the correct position.
46. Install and fully tighten rear mounting securing bolts.
47. Lower the transmission jack and return transmission jack to the storage area.
48. Detach the driveshaft from body structure (Illustration 12).

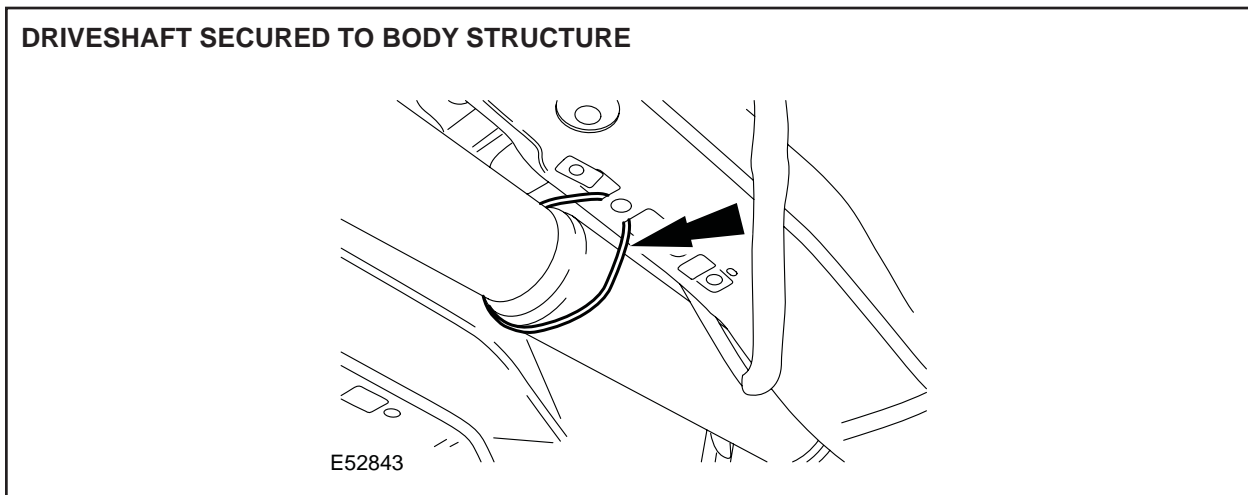

ILLUSTRATION 12

49. Attach the driveshaft to the transmission flange; install and tighten the securing bolts and tighten to 85 Nm.
50. Install the driveshaft heat shield; install and tighten the securing bolts to 5.5 Nm (Illustration 13).

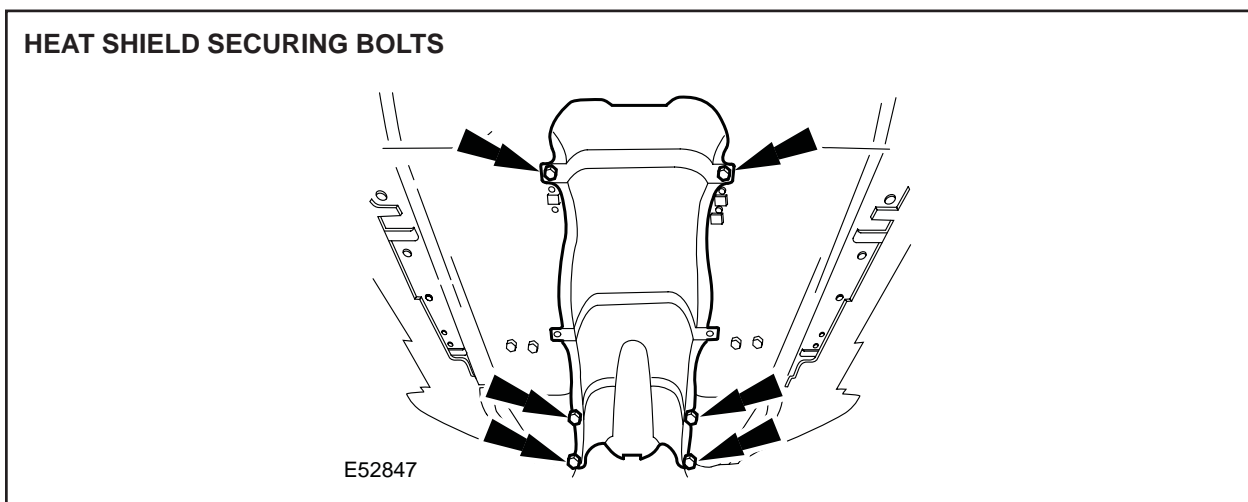

ILLUSTRATION 13



51. Install the exhaust system (see Global Technical Reference GTR Workshop Manual, section: 309-00).
52. Connect battery (see Global Technical Reference GTR Workshop Manual, section: 414-01).
53. Fill the transmission with oil (see Global Technical Reference GTR Workshop Manual, section: 307-01).
54. Ensure the ignition is switched 'OFF', parking brake is 'ON' and the transmission selector lever is in park.

**Note:** Ensure WDS is loaded with software release JTP 759/37 or later, switch on and allow software to load VIN input screen.

55. Connect PTU to vehicle using diagnostic cable.
56. Enter VIN and navigate to configuration main menu.
57. Select and run 're-configure existing PCM' application.
58. After the re-configuration of the PCM is complete, switch 'OFF' PTU, disconnect from vehicle and return WDS to original location.

### Global Technical Reference (GTR) Workshop Manual Information:

Dealer access: <https://hub.franchise.jaguar.com>

Internet access: <http://www.jaguartechno.com>

### Parts Information:

<u>DESCRIPTION</u>	<u>PART NUMBER</u>	<u>QTY</u>
Valve body kit	JLM 21752	1

### Warranty Information:

Warranty claims should be submitted quoting the information found in the table below. This will result in payment of the stated time and, where applicable parts/miscellaneous expense codes as listed.

Description	SRO	Time	Causal Part Number
Install a new valve body kit	44.91.31	3.8 hrs.	JLM 21752