



# Supercharger Cooling - Supercharger Cooling System Draining, Filling and Bleeding

General Procedures

## 1. WARNINGS:

 Never remove the coolant expansion tank pressure cap under any circumstances while the engine is operating. Failure to follow this instruction may result in personal injury.

 To avoid hot coolant or steam blowing out of the cooling system, use extreme care when removing the coolant expansion tank pressure cap. Wait until the engine has cooled down, then insulate the coolant pressure cap with a suitable cloth and slowly loosen the coolant expansion tank pressure cap until the cooling system pressure is released. Do not remove the coolant expansion tank pressure cap. Step back while the pressure is released from the system. When all of the pressure has been released slowly remove the coolant expansion tank pressure cap (still with the suitable cloth in position) from the coolant expansion tank. Failure to follow this instruction may result in personal injury.

 Prior to performing any under hood servicing in the area of the cooling fans when the engine is hot, disconnect the electrical supply to the cooling fans as the cooling fans may operate if the ignition is switched off. Failure to follow this instruction may result in personal injury.

Release the cooling system pressure.

- Remove the coolant expansion tank pressure cap.

## 2. Remove the radiator splash shield.

For additional information, refer to Section [501-02 Front End Body Panels](#).

## 3. Remove the radiator lower cowl.

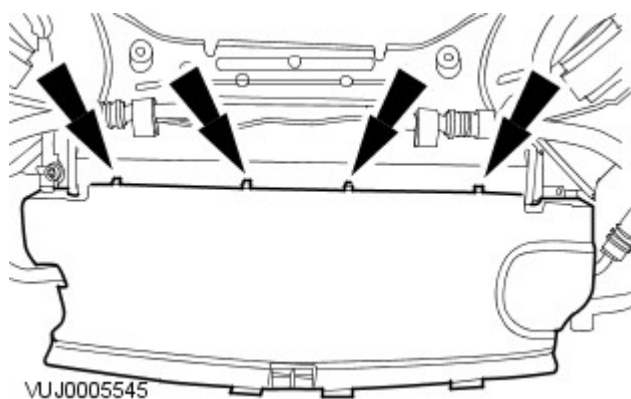

## 4. Remove the radiator drain plug.

- Drain the coolant into a suitable container.

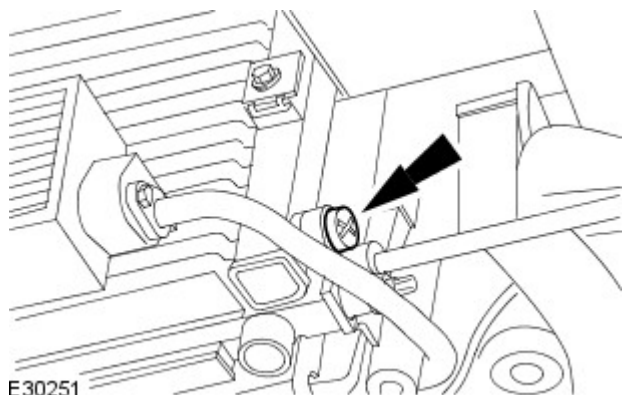

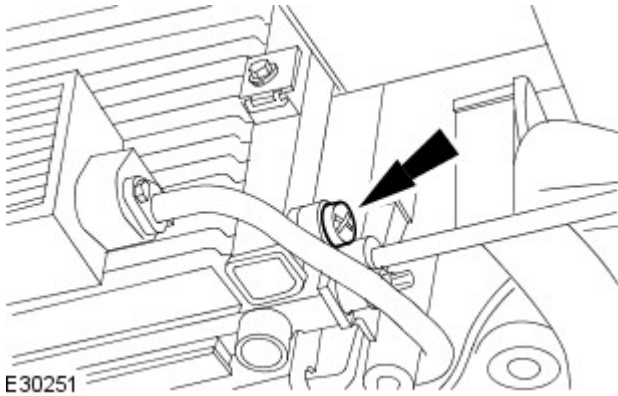

5.  **CAUTION:** Do not over tighten the radiator drain plug. Failure to follow this instruction may cause damage to the vehicle.

Install the radiator drain plug when all coolant has drained.

- Tighten to 1 Nm.
- Remove the container.
- Clean off any spillages.

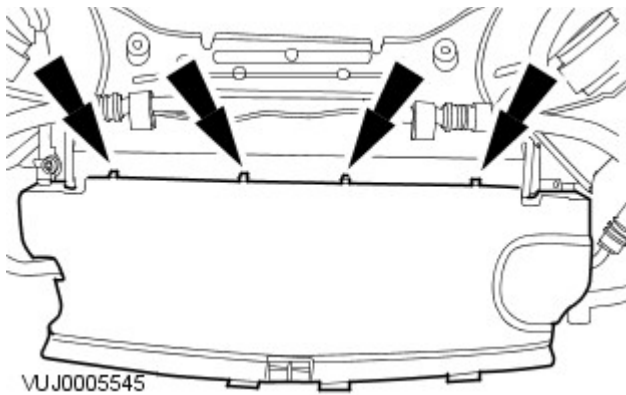



6. Install the radiator lower cowl.

7. Install the radiator splash shield.

For additional information, refer to Section [501-02 Front End Body Panels](#).

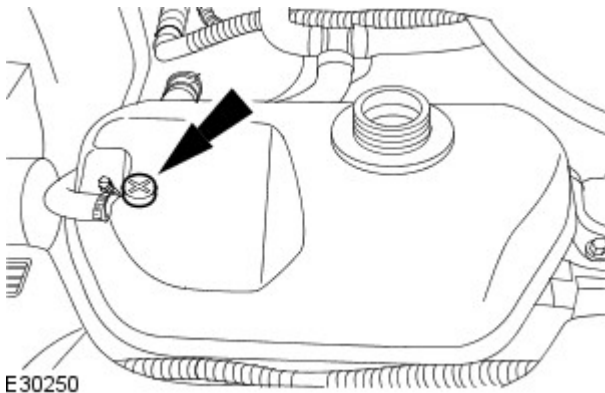
8. Remove the coolant expansion tank bleed screw.



9.  **CAUTION:** The supercharger cooling system must be maintained with the correct concentration and type of coolant solution to prevent corrosion and frost damage.

Fill the cooling system up to the MAX mark on the coolant expansion tank using a fifty percent mixture of Jaguar Premium Cooling System Fluid or equivalent, meeting Jaguar specification WSS M97B44-D and fifty percent water.

10.  **CAUTION:** Do not over tighten the coolant expansion tank bleed screw. Failure to follow this instruction may cause damage to the vehicle

Install the coolant expansion tank bleed screw.

- Tighten to 1 Nm.

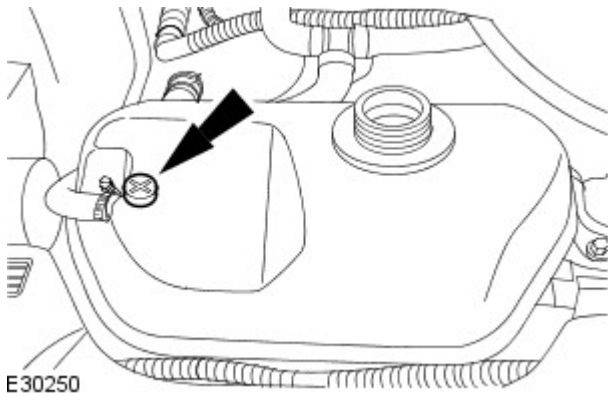

11. Install the coolant expansion tank pressure cap.

12. Remove the engine cover.

13. Remove the supercharger coolant filler plug.

- Remove and discard the sealing washer.

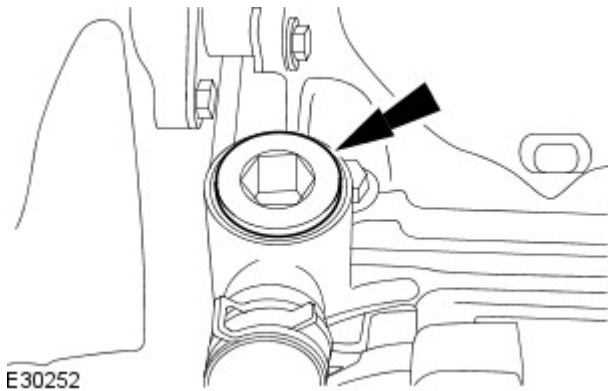

14. NOTE: Place a suitable cloth around supercharger fill port.

Top up the coolant through the supercharger fill port.

15.  CAUTION: Coolant may spill from supercharger fill port when ignition switched on.

Switch ignition on.

16.  CAUTION: Do not allow the supercharger water pump to run dry for more than one minute. Failure to follow this instruction may result in damage to the vehicle.

Allow the supercharger pump to run and top up the coolant through supercharger fill port.

17. Switch the ignition off.

18. Install the supercharger coolant fill plug.

- Install a new sealing washer.
- Tighten to 45 Nm.
- Clean off any spillages.

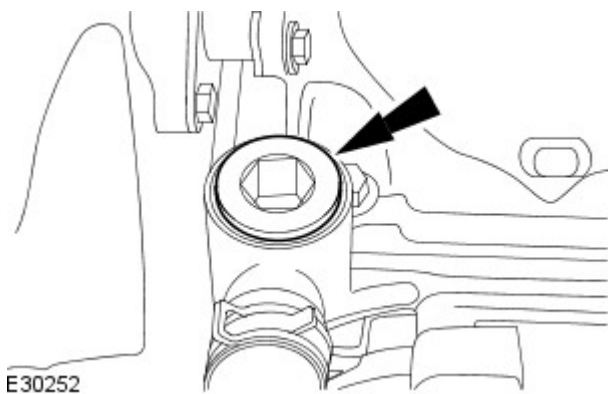

19. Install the engine cover.

20.  CAUTION: Do not RUN the engine with the coolant expansion tank pressure cap removed. Failure to follow this instruction may

cause damage to the vehicle

START and RUN the engine.

**21.** SET the heating system to MAX heat, the blower motor to MAX speed and the air distribution to instrument panel registers.

**22.**  **CAUTION:** Observe the engine temperature gauge. If the engine starts to over-heat switch off immediately and allow to cool. Failure to follow this instruction may cause damage to the vehicle.

Allow the engine to RUN until hot air is emitted from the instrument panel registers, while observing the engine temperature gauge.

**23.** Switch off the engine.

**24.** Allow the engine to cool.

**25.** Release the cooling system pressure.

- Remove the coolant expansion tank pressure cap.

**26.** Fill the cooling system up to the MAX mark on the coolant expansion tank using a fifty percent mixture of Jaguar Premium Cooling System Fluid or equivalent, meeting Jaguar specification WSS M97B44-D and fifty percent water.

**27.** Install the coolant expansion tank pressure cap.