





## Cooling System Draining, Filling and Bleeding

### All Vehicles

-  **WARNING:**  
NEVER REMOVE THE COOLANT PRESSURE CAP UNDER ANY CIRCUMSTANCES WHILE THE ENGINE IS OPERATING. FAILURE TO FOLLOW THIS INSTRUCTION MAY RESULT IN PERSONAL INJURY.  
  
TO AVOID HAVING SCALDING HOT COOLANT OR STEAM BLOW OUT OF THE COOLING SYSTEM, USE EXTREME CARE WHEN REMOVING THE COOLANT PRESSURE CAP FROM A HOT COOLING SYSTEM. WAIT UNTIL THE ENGINE HAS COOLED, THEN WRAP A THICK CLOTH AROUND THE COOLANT PRESSURE CAP AND TURN IT SLOWLY UNTIL THE PRESSURE BEGINS TO RELEASE. STEP BACK WHILE THE PRESSURE IS RELEASED FROM THE SYSTEM. WHEN CERTAIN ALL THE PRESSURE HAS BEEN RELEASED (STILL WITH A CLOTH) TURN AND REMOVE THE COOLANT PRESSURE CAP FROM THE COOLANT EXPANSION TANK. FAILURE TO FOLLOW THESE INSTRUCTIONS MAY RESULT IN PERSONAL INJURY.  
  
 **WARNING:**  
TO AVOID THE POSSIBILITY OF PERSONAL INJURY, DO NOT OPERATE THE ENGINE WITH THE HOOD OPEN UNTIL THE FAN BLADES HAVE BEEN EXAMINED FOR CRACKS AND SEPARATION. FAILURE TO FOLLOW THIS INSTRUCTION MAY RESULT IN PERSONAL INJURY.  
  
 **WARNING:**  
REMOVE FUSE 38 FROM THE ENGINE COMPARTMENT FUSE BOX PRIOR TO PERFORMING ANY UNDER HOOD SERVICE IN THE AREA OF THE COOLING FAN WHEN THE ENGINE IS HOT, SINCE THE COOLING FAN MOTOR COULD OPERATE IF THE ENGINE HAS BEEN SWITCHED OFF. FAILURE TO FOLLOW THIS INSTRUCTION MAY RESULT IN PERSONAL INJURY.  
  
 **CAUTION:**  
The engine cooling system must be maintained with the correct concentration and type of anti-freeze solution to prevent corrosion and frost damage.  
  
 **CAUTION:**  
Never remove the coolant pressure cap under any circumstances while the engine is operating. Failure to follow this instruction may result in damage to the engine.
- Relieve the cooling system pressure.
- Unscrew the coolant expansion tank cap slowly.
2. Remove the coolant expansion tank cap.
  3. Remove the radiator splash shield. <<501-02>>

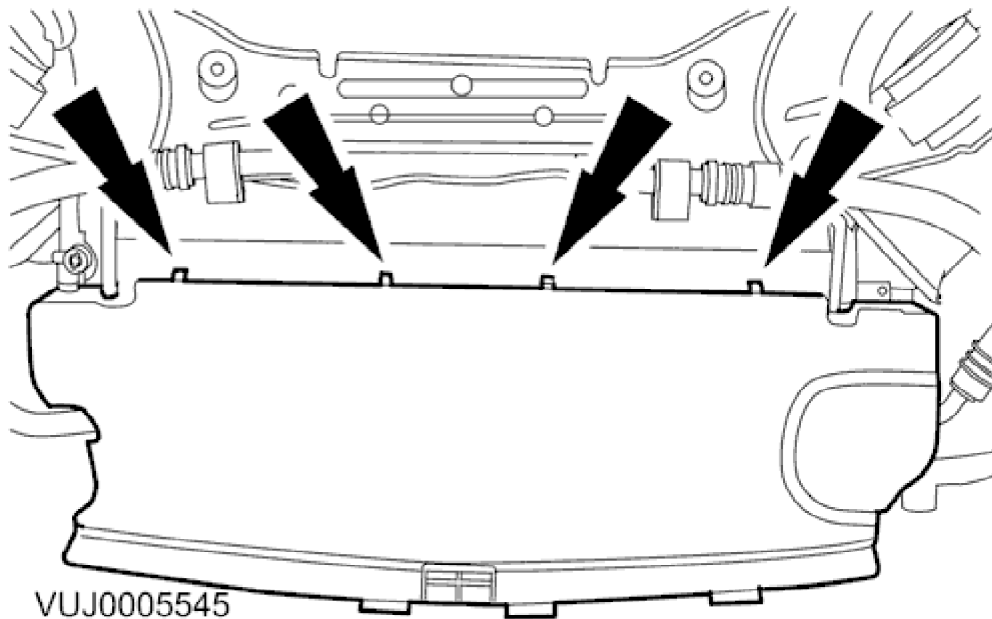

4. Remove the radiator lower cowl.

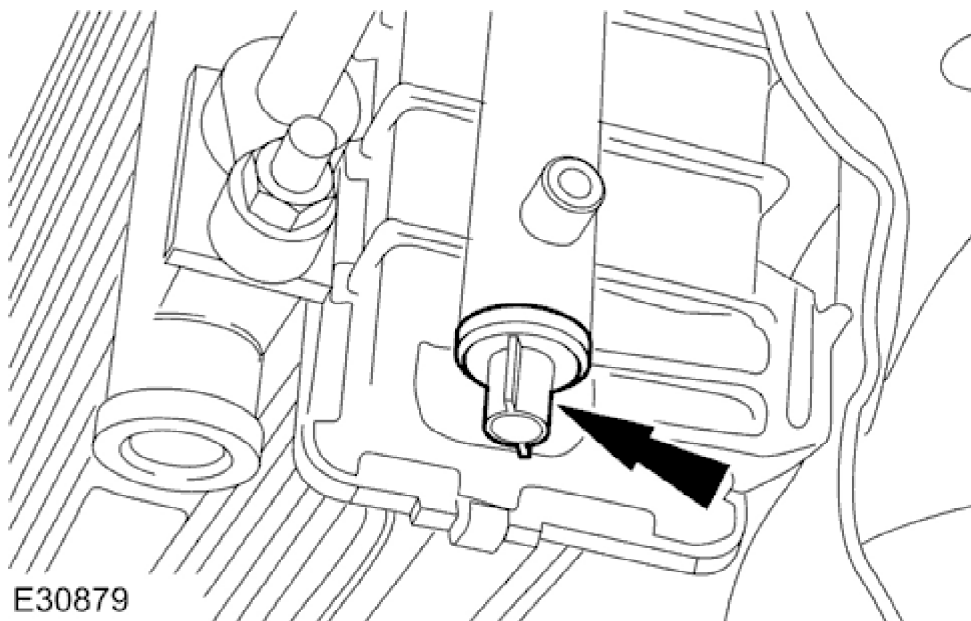

5. Remove the coolant drain plug.  
• Drain the coolant into a suitable container.

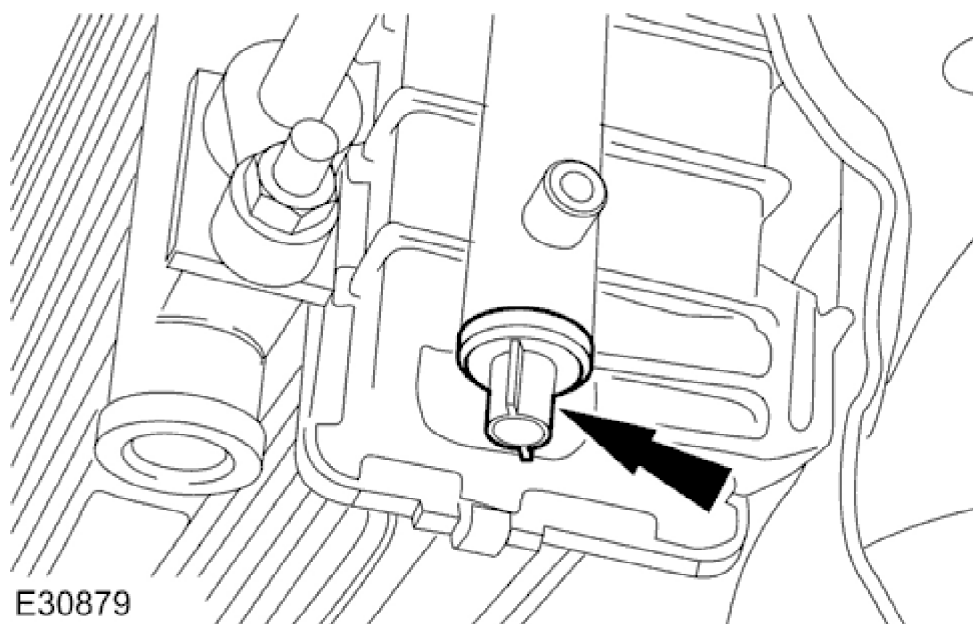

E30879

6.  **CAUTION:**  
Do not over tighten the drain plug. Failure to follow this instruction may cause damage to the vehicle.

Install the drain plug when all coolant has drained.

- Tighten to 1 Nm.
- Remove the drain tray.

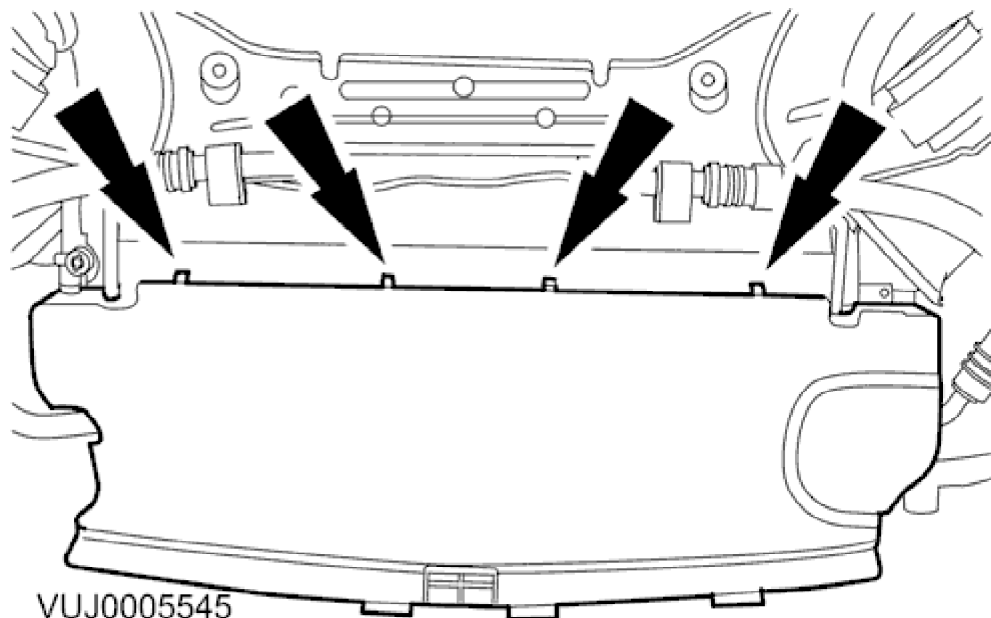

VUJ0005545

7. Install the radiator lower cowl.

8. Install the radiator splash shield. <<501-02>>

**Vehicles without supercharger**

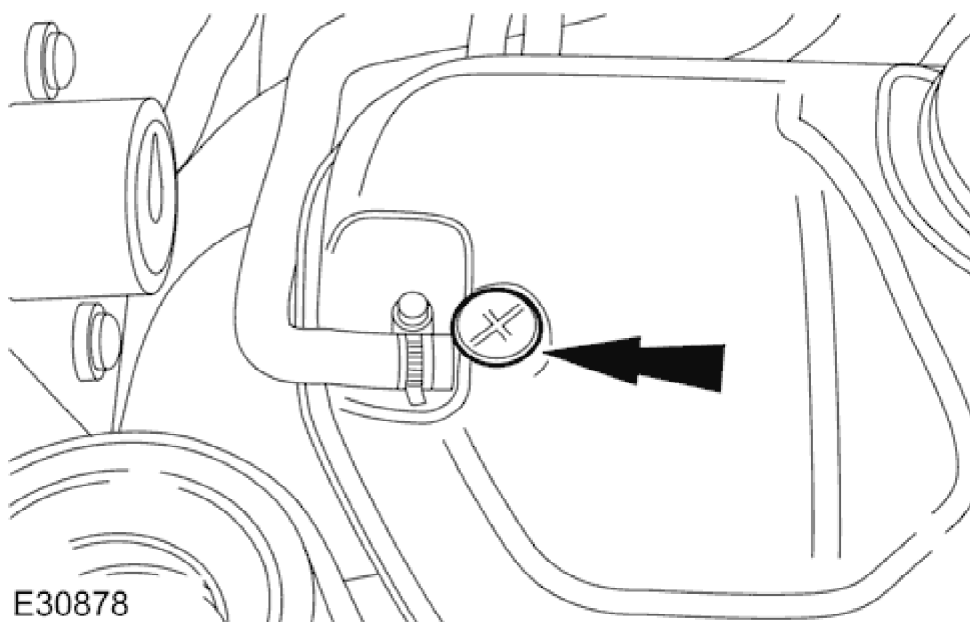

9. Remove the coolant expansion tank bleed screw.

10. Fill the cooling system up to the MAX mark on the coolant expansion tank using a fifty percent mixture of Jaguar Premium Cooling System Fluid or equivalent, meeting Jaguar specification WSS M97B44-D and fifty percent water.

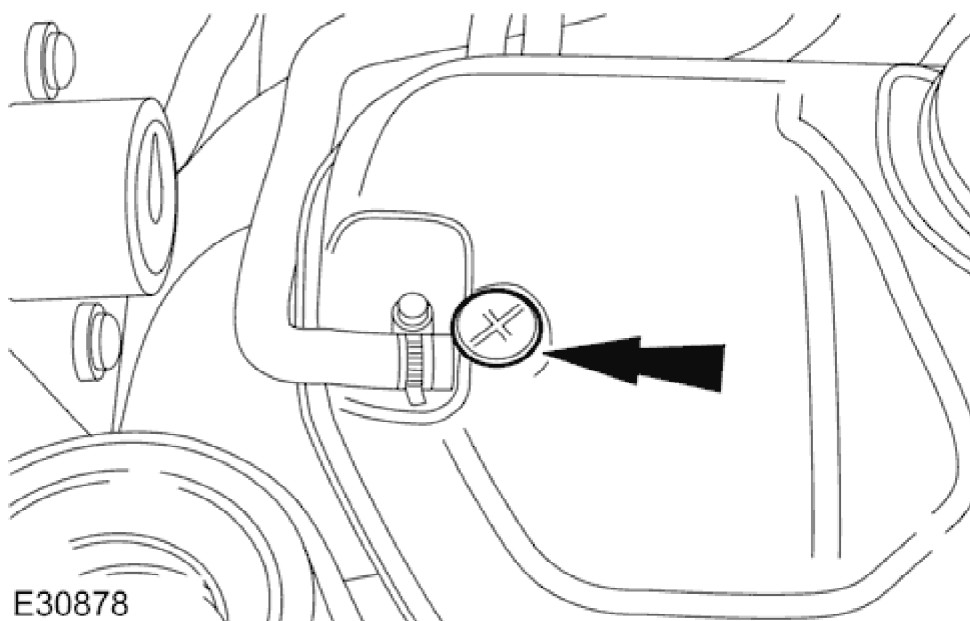

11.  **CAUTION:**  
**Do not over tighten the coolant expansion tank bleed screw. Failure to follow this instruction may cause damage to the vehicle**

Install the coolant expansion tank bleed screw.

- Tighten to 1 Nm.

12. Install the coolant expansion tank pressure cap.

## 2003 S-TYPE - Engine Cooling - 303-03A

13.  **CAUTION:**  
**Do not RUN the engine with the coolant expansion tank pressure cap removed. Failure to follow this instruction may cause damage to the vehicle**

START and RUN the engine.

14. SET the heating system to MAX heat, the blower motor to MAX speed and the air distribution to instrument panel registers.

15.  **CAUTION:**  
**Observe the engine temperature gauge. If the engine starts to over-heat switch off immediately and allow to cool. Failure to follow this instruction may cause damage to the vehicle.**

Allow the engine to RUN until hot air is emitted from the instrument panel registers, while observing the engine temperature gauge.

16. Switch off the engine.

17. Allow the engine to cool.

18. Release the cooling system pressure.  
• Remove the coolant expansion tank pressure cap.

19. Fill the cooling system up to the MAX mark on the coolant expansion tank using a fifty percent mixture of Jaguar Premium Cooling System Fluid or equivalent, meeting Jaguar specification WSS M97B44-D and fifty percent water.

20. Install the coolant expansion tank pressure cap.