



## INSTALLATION INSTRUCTIONS FOR PART 99-9500

**APPLICATIONS**  
**JAGUAR S-TYPE**  
**2003-2006**  
**JAGUAR X-TYPE**  
**2002-2007**

# 99-9500

### KIT FEATURES

- DIN Radio Provision with Removable Pocket



### KIT COMPONENTS

A) Radio Housing B) Pocket

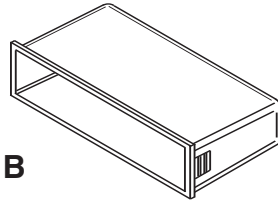
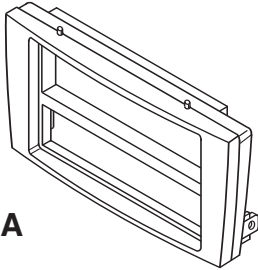

### TOOLS REQUIRED:

- Small Flat Blade Screwdriver/ Panel Removal Tool
- Torx Screwdriver
  - Socket Set



1-800-221-0932



[www.metraonline.com](http://www.metraonline.com)

© COPYRIGHT 2007 METRA ELECTRONICS CORPORATION



**TABLE OF CONTENTS**

**Dash Disassembly**

- **Jaguar S-Type 2003-2006 . . . . . 1,2**
- **Jaguar X-Type 2002-2007 . . . . . 3,4**

**Kit Assembly**

- **DIN Radio Provision with Removable Pocket . . . . . 5**

- **Final Assembly . . . . . 6**

**\*Note:**

**Refer also to the instructions included with the aftermarket radio.**

## JAGUAR S-TYPE 2003-2006

- 1** Disconnect the negative battery terminal to prevent an accidental short circuit.
- 2** Remove cup holder and (2) screws securing center console storage compartment and remove compartment. (Figure A)
- 3** Unclip and remove the trim panel around the shifter. (Figure B)

*Continued on page 2*

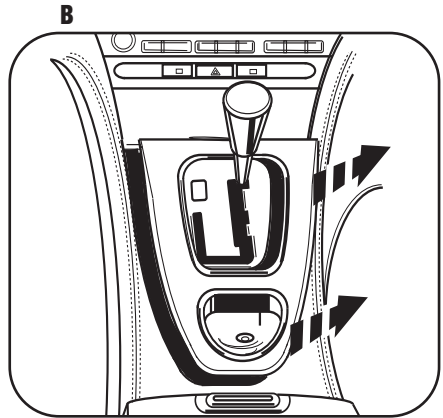
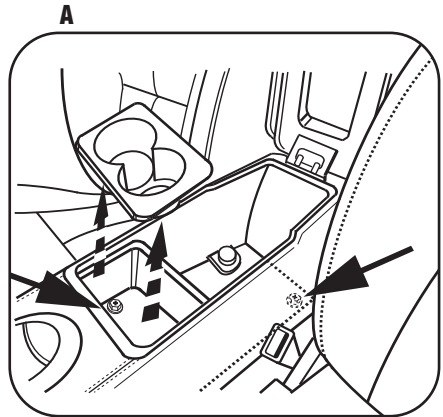

## JAGUAR S-TYPE 2003-2006

- 4** Unclip and remove the trim panel surrounding the radio/climate controls/ashtray and front half of the center console. (Figure C)
- 5** Remove (4) screws securing the radio/climate control assembly to the dash. Unplug and remove assembly. (Figure D)
- 6** Remove (4) screws securing the radio to the assembly and remove the radio. Retain the assembly for re-use during kit assembly.

*Continue to kit assembly*

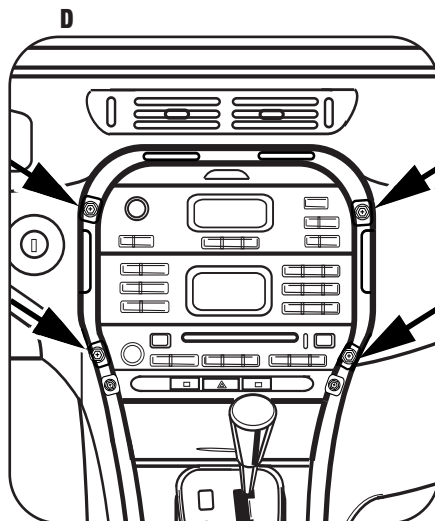
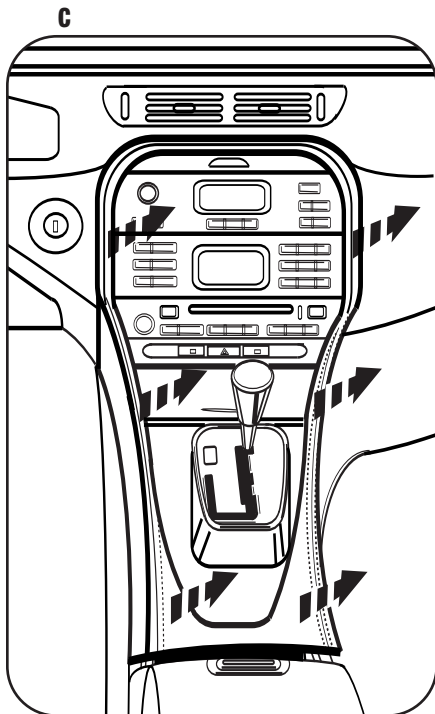

## JAGUAR X-TYPE 2002-2007

- 1 Disconnect the negative battery terminal to prevent an accidental short circuit.
- 2 Unclip and remove the trim panel around the shifter. (Figure A)
- 3 Remove (2) screws from bottom edge of ashtray assembly then unclip and remove ashtray assembly. (Figure B)
- 4 Remove (2) screws from inside ashtray cavity at bottom edge of radio. (Figure C)

*Continued on page 4*

**A**

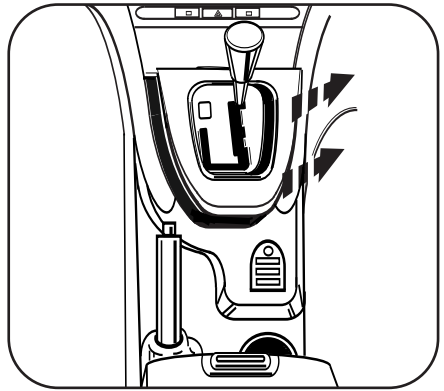

**B**

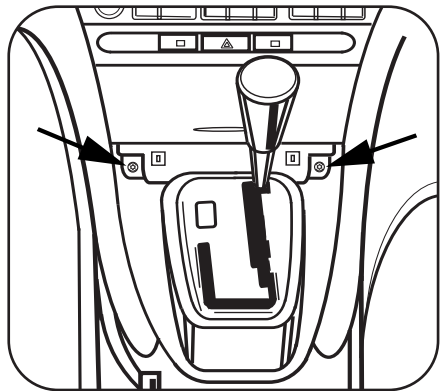

**C**

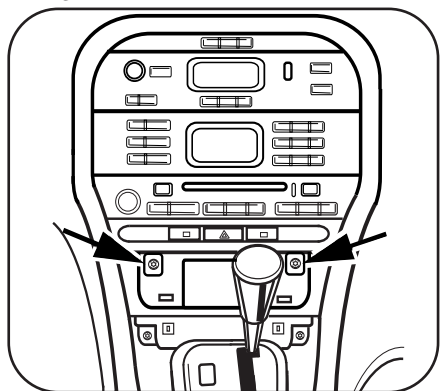

## JAGUAR X-TYPE 2002-2007

- 5 Unclip, unplug and remove hazard switch/seat heater switch trim panel above climate control/radio assembly. (Figure D)
- 6 Remove (2) screws from inside switch panel cavity at top edge of climate controls. (Figure E)
- 7 Unplug and remove the climate control/radio assembly. (Figure F)
- 8 Remove (4) screws securing the radio to the assembly and remove the radio. Retain the assembly for re-use during kit assembly.

*Continue to kit assembly*

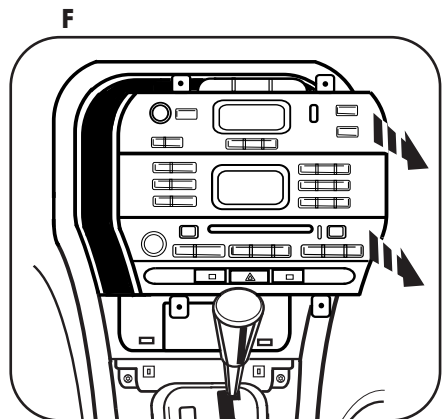
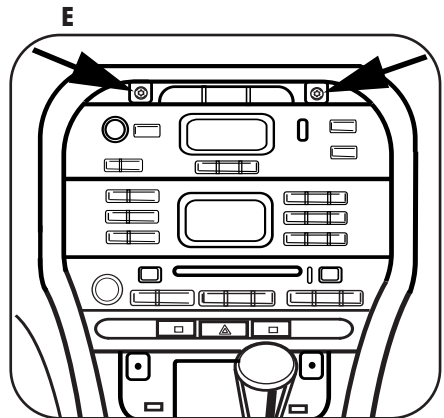
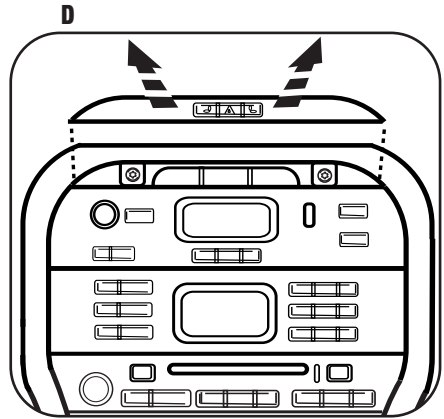

# **DIN RADIO PROVISION-REMOVABLE POCKET**

## **JAGUAR S-TYPE 2003-06/X-TYPE 2002-07**

*Note: Refer also to the instructions included with the aftermarket radio.*

- 1** Mount the factory climate controls assembly to the radio housing. (Figure A)
- 2** Slide the DIN cage into the bottom of the Radio Housing and secure by bending the metal locking tabs outward. (Figure B)
- 3** Slide the aftermarket radio into the cage until it snaps into place. (Figure C)
- 4** Snap the pocket into the top of the radio housing. (Figure D)

*Continue to final assembly.*

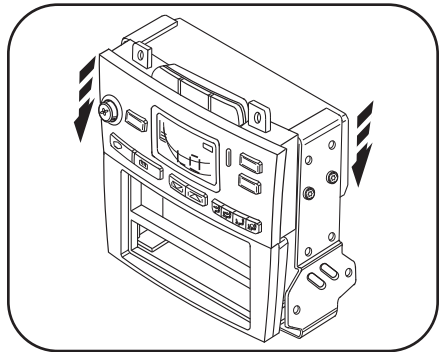
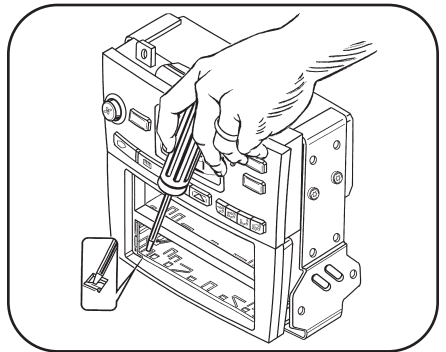
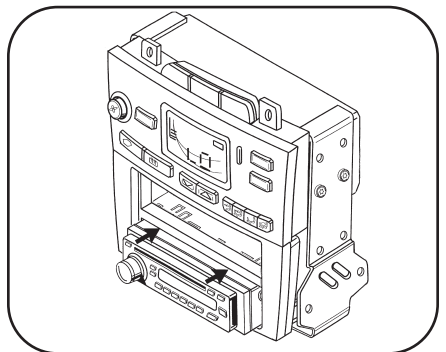
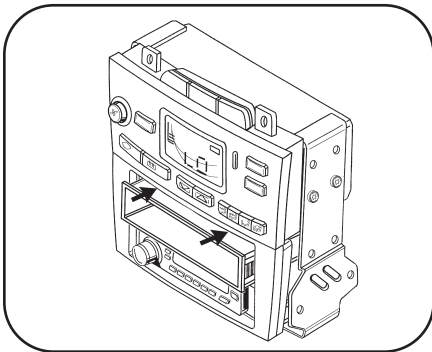
**A****B****C****D**



# FINAL ASSEMBLY

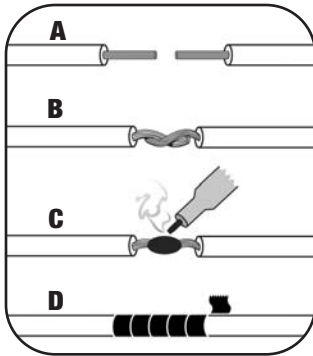

- (A) Strip wire ends back 1/2"**
- B) Twist ends together**
- C) Solder**
- D) Tape**

- 1** Locate the factory wiring harness in the dash. Metra recommends using the proper mating adapter and making connections as shown. (Isolate and individually tape off the ends of any unused wires to prevent electrical short circuit.)
- 2** Re-connect the negative battery terminal and test the unit for proper operation.
- 3** Reassemble radio and dash assemblies in reverse order of disassembly.

## FINAL WIRING CONNECTIONS

Make wiring connections using the EIA color code chart shown below and the instructions included with the head unit. Metra recommends making connections as shown below; Strip, Splice, Solder, Tape. Isolate and individually tape off ends of any unused wires to prevent electrical short circuit.

### METRA / EIA WIRING CODE

12V Ignition / Acc. . . . . Red	Right Front (+) . . . . . Gray
12V Batt / Memory . . . . . Yellow	Right Front (-) . . . . . Gray/ Black
Ground . . . . . Black*	Left Front (+) . . . . . White
Power Antenna . . . . . Blue	Left Front (-) . . . . . White / Black
Amp Turn-On . . . . . Blue / White	Right Rear (+) . . . . . Violet
Amp Ground . . . . . Black / White	Right Rear (-) . . . . . Violet / Black
Illumination . . . . . Orange	Left Rear (+) . . . . . Green
Dimmer . . . . . Orange / White	Left Rear (-) . . . . . Green / Black

**\*NOTE:** When a Black wire is not present, ground radio to vehicle chassis.  
All colors may not be present on all leads due to manufacturer's specifications.









# 99-9500 INSTRUCTIONS



**1-800-221-0932**



**[www.metraonline.com](http://www.metraonline.com)**

REV. 11/26/07 © COPYRIGHT 2007 METRA ELECTRONICS CORPORATION INST99-9500