



**ON-BOARD DIAGNOSTICS  
V6 ENGINE MANAGEMENT SYSTEM**

**Vehicle Coverage:**

S-Type 2006 MY Onwards

XJ 2006 MY Onwards

## 1 Contents

1	Contents	2
2	Introduction	5
2.1	Inputs and Outputs	5
3	Mode \$06 Data	8
3.1	Functional Description	8
3.1.1	Reporting of On-Board Diagnostic Monitor ID test values in response to \$06 \$00 request.	9
3.1.2	Reporting of On-Board Diagnostic Monitor ID test values in response to \$06 \$01 - \$FF request.	10
3.1.3	Unit and Scaling ID definition	11
3.1.4	Test Result Description	12
3.1.5	Example for Use of Standardised Test IDs for Misfire Monitor	16
4	Onboard Monitoring	18
4.1	Catalyst Monitoring	18
4.1.1	Description	18
4.1.2	Monitoring Structure	19
4.1.3	Drive Cycle Information	20
4.2	Misfire Monitoring	20
4.2.1	Description	20
4.2.2	Strategy Description	20
4.2.3	Drive Cycle Information	20
4.3	Evaporative Emission System Monitoring	20
4.3.1	Schematic	20
4.3.2	Description	20
4.3.3	Typical monitoring results	20
4.3.4	Strategy Flowchart	20
4.3.5	Evaporative Emission Canister Purge Valve	20
4.3.6	Purge Flow Strategy Flowchart	20
4.3.7	Drive Cycle Information	20
4.4	Fuel System Monitoring	20
4.4.1	Description	20
4.4.2	Strategy Flowchart	20
4.4.3	Drive Cycle Information	20
4.5	Oxygen Sensor Monitoring	20
4.5.1	Upstream Oxygen Sensor High Low Monitor	20
4.5.2	Upstream Oxygen Sensor Slow Response	20
4.5.3	Upstream Oxygen Sensor Slow Activation	20
4.5.4	Downstream Oxygen Sensor High or Low Monitor	20
4.5.5	Downstream Oxygen Sensor Stuck Monitor	20
4.5.6	Downstream Oxygen Sensor Rationality Check	20

---

4.5.7	Drive Cycle Information	20
4.6	Thermostat Monitoring	20
	System Schematic	20
4.6.2	Description	20
4.7	Idle Speed Control	20
4.7.1	Description	20
4.8	Crankshaft Position and Engine Speed Sensor	20
4.8.1	Description	20
4.9	Camshaft Position Sensors	20
4.9.1	Description	20
4.10	Engine Coolant Temperature (ECT) Sensor	20
4.10.1	Sensor Stuck	20
4.10.2	Range or Performance Failure	20
4.10.3	Time to Closed Loop Fuelling	20
4.10.4	Range/Performance Flow chart	20
4.11	Manifold Absolute Pressure Sensor	20
4.11.1	High or Low Input Failure and Ground Monitor	20
4.11.2	Range / Performance Failure	20
4.11.3	Flow Chart	20
4.12	Mass Airflow Sensor	20
4.12.1	High or Low Input Failure and Ground Monitor	20
4.12.2	Range / Performance Failure	20
4.12.3	Flow Chart	20
4.13	Barometric Pressure Sensor	20
4.13.1	High /Low Input Failure	20
4.13.2	Range / Performance Failure	20
4.14	Fuel Rail Pressure Sensor	20
4.14.1	High / Low Input Failure	20
4.14.2	Range Performance	20
4.14.3	Fuel System Pressure	20
4.15	Intake Air Temperature Sensor	20
4.15.1	Sensor Stuck	20
4.15.2	Range or Performance Failure	20
4.15.3	Range/Performance Flow chart	20
4.16	Engine Oil Temperature Sensor	20
4.16.1	Sensor Stuck	20
4.16.2	Range or Performance Failure	20
4.16.3	Range/Performance Flow Chart	20
4.17	Fuel Rail Temperature Sensor	20
4.17.1	Sensor Stuck	20
4.17.2	Range or Performance Failure	20

---

4.17.3	Range /Performance Flow Chart	20
4.17.4	Sensor Stuck Flow Chart	20
4.18	Knock Sensor	20
4.19	ECM Power Supplies	20
4.19.1	Description	20
4.20	Engine Control Module Self Test	20
4.20.1	Description	20
4.21	Engine Starting	20
4.21.1	Crank request Signal	20
4.21.2	Park / Neutral Switch	20
4.21.3	Starter relay	20
4.22	Accelerator Pedal Position Sensor	20
4.22.1	Description	20
4.23	Throttle Control System	20
4.23.1	Description	20
4.24	Torque Monitoring	20
4.24.1	Description	20
4.25	Vehicle Speed Signal	20
4.25.1	Description	20
4.26	Fuel Injectors	20
4.26.1	Description	20
4.27	Ignition Amplifiers / Coils	20
4.27.1	Description	20
4.28	Variable Valve Timing	20
4.28.1	Hardware Check	20
4.28.2	Camshaft Position	20
4.28.3	Camshaft Adaption	20
4.29	Cold Start Emission Reduction Strategy	20
4.30	Secondary Air Injection System	20
4.31	Controller Area Network System	20
4.31.1	Invalid signal Error	20
4.31.2	Loss of Communications	20
4.32	Fuel Level Sensor	20
4.33	Engine Off Timer	20
4.33.1	Description	20
4.34	Ambient Air Temperature	20
4.34.1	Description	20
4.35	Intake Manifold Tuning Valve System	20

## 2 Introduction

### 2.1 Inputs and Outputs

Input Signals	Monitored by OBD II
• Transmission Control Module (via CAN)	Yes - Bus check
• Engine coolant temperature (ECT)	Yes
• Intake Air Temperature (IAT)	Yes
• Mass Air Flow (MAF)	Yes
• O2 Sensors	Yes
• Crankshaft Position/Speed (CKP)	Yes
• Camshaft Position (CMP)	Yes
• Throttle Position (TP)	Yes
• Manifold Pressure	Yes
• Fuel rail pressure	Yes
• Accelerator Pedal Position (APP)	Yes
• Vehicle Speed (VS) (ABS via CAN)	Yes
• Ambient Temperature (Instrument Pack via CAN)	Yes
• Knock Sensors	Yes
• Diagnosis Module - Leak Detection (EVAP System)	Yes
• Brake Light Switch (BLS)	No
• Speed Control Switches	No
• Immobiliser (via CAN)	No
• Alternator Monitor	No
• Fuel Temperature	Yes
• Engine Oil Temperature (EOT)	Yes

Input Signals	Monitored by OBD II
• Real Time Clock (Instrument Pack via CAN)	Yes
• Fuel Tank Level (Instrument Pack via CAN)	Yes
• Fuel pump Monitor	No
• Ignition Switch	No
• Crank Request	Yes
• Park/Neutral Switch	Yes
• Atmospheric Pressure	Yes
• Air Conditioning System Pressure	No
• Inertia Switch	No
• Active Speed Limiter Switch	No

Output Signals	Monitored by OBD II
• Transmission Control Module (via CAN)	Yes – Signals checked separately
• Throttle Valve Actuator	Yes
• Ignition Coils	Yes
• Injection Valves	Yes
• Evaporative Emission (EVAP) Canister Purge Valve	Yes
• Diagnosis Module - Leak Detection (EVAP System)	Yes
• Malfunction Indicator Light (MIL) (via CAN)	Not directly
• O2 Sensor Heating	Yes
• Exhaust Gas Recirculation (EGR) Valve	Yes
• Fuel Pump (FP) Relay	No
• Engine Starter Relay	Yes
• ECM Main Relay	Yes

---

Output Signals	Monitored by OBD II
• Variable Valve Timing Valves	Yes
• Fuel pump control	Yes
• Alternator Control	Yes
• ECM Cooling Fan	No
• Air Conditioning Clutch Relay	No
• Secondary Air Injection	Yes
• Intake Manifold Tuning Valves	Yes

### 3 Mode \$06 Data

#### 3.1 Functional Description

The purpose of mode \$06 is to allow access to the results for on-board diagnostic monitoring tests of specific components / systems that are continuously monitored (e.g. misfire monitoring) and non-continuously monitored (e.g. catalyst system).

The request message for test values, consists of two bytes, byte #1 specifies what service is to respond e.g. \$06 for Mode \$ 06 request. Byte #2 specifies which On-Board Diagnostic Monitor ID (OBDMID) information is being requested i.e. any supported On-Board Diagnostic Monitor ID from \$00 to \$FF (see table 5).

**Table 1**

Data Byte	Parameter Name	Hex Value
#1	Request supported on-board monitoring IDs (Read supported On-Board Diagnostic Monitor IDs)	06
#2	On-Board Diagnostic Monitor ID	XX (see table 5)





### 3.1.2 Reporting of On-Board Diagnostic Monitor ID test values in response to \$06 \$01 - \$FF request.

A minimum of 10 bytes will be returned in response to this type of request. The maximum amount of bytes is dependant on how many Test IDs are supported within the On-Board Diagnostic Monitor ID.

#### Test ID

Response	On-Board Diagnostic Monitor ID	TID	Scaling ID	Test Result	Min Test Result	Max Test Result
46	00	00	00	00 00	00 00	00 00

A Test ID (TID) is a one (1) byte parameter that describes the test(s) carried out within the On-Board Diagnostic Monitor ID.

**Table 3**

Data Byte	Parameter Name	Range (Hex)
#3	Manufacturer Defined Test ID range - this parameter is an identifier for the test performed within the On-Board Diagnostic Monitor.	Test ID 80 – FE (see table 5)

When more than one TID is to be reported, the returning data will be continuous, only displaying \$46 once (first 10 bytes). The following TIDs will be displayed in 9 bytes, omitting the Response ID \$46, Therefore, starting with the On-Board Diagnostic Monitor ID requested. For example, \$06 \$01 will return the following:

**Fig 1**

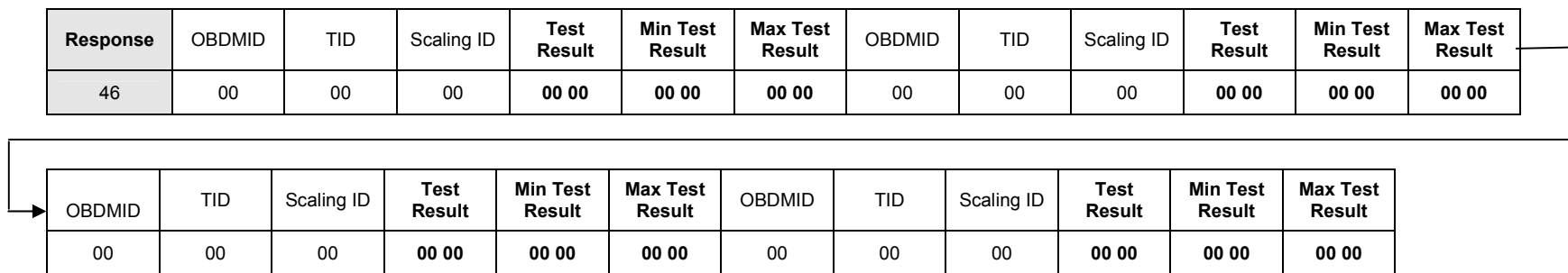

### 3.1.3 Unit and Scaling ID definition

Response	OBDMID	TID	Scaling ID	Test Result	Min Test Result	Max Test Result
46	00	00	00	00 00	00 00	00 00

The Unit and Scaling ID is a one (1) byte identifier. This references the scaling and units to be used by external test equipment when calculating and displaying the test values (results). This includes the minimum test limit and the maximum test limit for the standardised and manufacturer defined Test ID requested.

All unit and scaling IDs used are specified in Table 4.

**Table 4**

Unit and Scaling ID (hex)	Description	Scaling/bit	Minimum value		Maximum value		External test equipment SI (Metric) display	
			(hex)	(dec.)	(hex)	(dec.)		
01	Raw Value	1 per bit hex to decimal unsigned	0000	0	FFFF	65535	xxxxx	
			Data Range examples:				Display examples:	
			\$0000		+65535		0	
			\$FFFF				65535	
Unit and Scaling ID (hex)	Description	Scaling/bit	Minimum value		Maximum value		External test equipment SI (Metric) display	
			(hex)	(dec.)	(hex)	(dec.)		
24	Counts	1 count per bit counts unsigned	0000	0 counts	FFFF	65535	xxxxx	
			Data Range examples:				Display examples:	
			\$0000		0 counts		0	
			\$FFFF		+65535 counts		65535	

### 3.1.4 Test Result Description

Response	OBDMID	TID	Scaling ID	Test Result	Min Test Result	Max Test Result
46	00	00	00	00 00	00 00	00 00

The latest test results are retained, even over multiple ignition OFF cycles, until replaced by more recent test results. Test results are requested by On-Board Diagnostic Monitor ID. Test results are always reported with the Minimum and Maximum Test Limits as shown in Table 5.

The Test Limit is a two byte unsigned numeric value \$00-\$FFFF (0 -65535 Dec). With exception to Misfire (On-Board Diagnostic Monitor ID A2-A9), all specific Max Test limits shall be \$7FFF (32767 Dec). Test values less than or equal to the Max test limit will be show as \$00, indicating a pass. Test values greater than Max test limit indicate a fail.

#### Pass

Response	OBDMID	TID	Scaling ID	Test Result	Min Test Result	Max Test Result
46	00	00	00	00 00	00 00	7F FF

#### Fail

Response	OBDMID	TID	Scaling ID	Test Result	Min Test Result	Max Test Result
46	00	00	00	9F 34	00 00	7F FF

If an On-Board Diagnostic Monitor has not been completed at least once since Clear/reset emission-related diagnostic information or battery disconnect, then the parameters Test Results, Minimum Test Limit, and Maximum Test Limit shall be set to zero (\$00) value, indicating test has not been completed.

Table 5 (overleaf) contains specific Mode \$06 related data. This table is to be used as a tool to cross reference any data received by a generic scan tool and identify any On-Board Diagnostic Monitor ID, PCODE, TID, Min, Max Values and scaling information.

**Example**

See "Test Result" information

Response	OBDMID	TID	Scaling ID	Test Result	Min Test Result	Max Test Result
46	00	00	00	09 FF	00 00	7F FF

**Preview of Table 5**

OBDMIDs (On-Board Diagnostic Monitor ID) definition for mode \$06								
OBD MID	On-Board Diagnostic Monitor ID name	PCode	Test ID	Test ID Description	Min. Test Limit	Max. Test Limit	Unit & Scaling	
00	OBDMonitor IDs supported (\$01 - \$20)	-	-	-	-	-	-	-
01	Oxygen Sensor Monitor Bank 1 - Sensor 1	P01301A Low	80	Element high/low fault A	0000	7FFF	01	
		P01301B High						
		P013100 Low	81	Signal continuous/intermittent high/low A	0000	7FFF	01	
		P013200 High						
P013300	82	Slow response A	0000	7FFF	01			
P013400								
02	Oxygen Sensor Monitor Bank 1 - Sensor 2	P013700 Low	84	High/Low input A	0000	7FFF	01	
		P013800 High						
		P014000	85	Stuck A	0000	7FFF	01	

**Table 5**

OBDMIDs (On-Board Diagnostic Monitor ID) definition for Mode \$06							
OBD MID	On-Board Diagnostic Monitor ID name	PCode	Test ID	Test ID Description	Min. Test Limit	Max. Test Limit	Unit & Scaling
<b>00</b>	<b>OBD Monitor IDs supported (\$01 - \$20)</b>	-	-	-	-	-	-
<b>01</b>	Oxygen Sensor Monitor Bank 1 - Sensor 1	P0130 Low P0130 High	80	Element high/low fault A	0000	7FFF	01
		P0133	82	Slow response A	0000	7FFF	01
		P0134	83	Slow activation A	0000	7FFF	01
<b>02</b>	Oxygen Sensor Monitor Bank 1 - Sensor 2	P0137 Low P0138 High	84	High/Low input A	0000	7FFF	01
		P0140	85	Stuck A	0000	7FFF	01
		P0139	86	Slow response A	0000	7FFF	01
<b>05</b>	Oxygen Sensor Monitor Bank 2 - Sensor 1	P0150 Low P0150 High	80	Element high/low fault B	0000	7FFF	01
		P0153	82	Slow response B	0000	7FFF	01
		P0154	83	Slow activation B	0000	7FFF	01
<b>06</b>	Oxygen Sensor Monitor Bank 2 - Sensor 2	P0157 Low P0158 High	84	High/Low input B	0000	7FFF	01
		P0160	85	Stuck B	0000	7FFF	01
		P0159	86	Slow response B	0000	7FFF	01
<b>20</b>	<b>OBD Monitor IDs supported (\$21 - \$40)</b>	-	-	-	-	-	-
<b>21</b>	Catalyst Monitor Bank 1	P0420	88	Low efficiency A	0000	7FFF	01
<b>22</b>	Catalyst Monitor Bank 2	P0430	88	Low efficiency B	0000	7FFF	01
<b>31</b>	EGR Monitor Bank 1	P0401	89	flow check	0000	7FFF	01
		P0490 High P0489 Low	8A	Electrical high/low	0000	7FFF	01
<b>3B</b>	EVAP Monitor (0.040") 8B Rough leak	P0455	8B	Rough leak	0000	7FFF	01
<b>3C</b>	3C EVAP Monitor (0.020")	P0455	8C	Medium leak	0000	7FFF	01
		P0442	8D	Small leak	0000	7FFF	01

**OBDMIDs (On-Board Diagnostic Monitor ID) definition for Mode \$06**

<b>OBD MID</b>	<b>On-Board Diagnostic Monitor ID name</b>	<b>PCode</b>	<b>Test ID</b>	<b>Test ID Description</b>	<b>Min. Test Limit</b>	<b>Max. Test Limit</b>	<b>Unit &amp; Scaling</b>
<b>3D</b>	Purge Flow Monitor	P0459 High P0458 low	8E	High/Low fault	0000	7FFF	01
		P0441	8F	Range / performance	0000	7FFF	01
<b>40</b>	<b>OBDMonitor IDs supported (\$41 - \$60)</b>	-	-	-	-	-	-
<b>41</b>	Oxygen Sensor Heater Monitor Bank 1 - Sensor 1	P0032 High P0031 Low	90	Electrical high/low fault A	0000	7FFF	01
<b>42</b>	Oxygen Sensor Heater Monitor Bank 1 - Sensor 2	P0036 Heater A P0131 Heater circuit A	91	Heater & Heater circuit A	0000	7FFF	01
<b>45</b>	Oxygen Sensor Heater Monitor Bank 2 - Sensor 1	P0052 High P0051 Low	90	Electrical high/low fault B	0000	7FFF	01
<b>46</b>	Oxygen Sensor Heater Monitor Bank 1 - Sensor 2	P0056 Heater B P0161 Heater circuit B	91	Heater & Heater circuit B	0000	7FFF	01
<b>60</b>	<b>OBDMonitor IDs supported (\$61 - \$80)</b>	-	-	-	-	-	-
<b>71</b>	Secondary Air Monitor 1	P2445	97	Air flow High/Low	0000	7FFF	01
<b>80</b>	<b>OBDMonitor IDs supported (\$81 - \$A0)</b>	-	-	-	-	-	-
<b>81</b>	Fuel System Monitor Bank1	P0171 lean P0172 Rich	92	Lean/Rich fault A	0000	7FFF	01
<b>82</b>	Fuel System Monitor Bank 2	P0174 lean P0175 Rich	92	Lean/Rich fault B	0000	7FFF	01
<b>A0</b>	<b>OBDMonitor IDs supported (\$A1 - \$C0)</b>	-	-	-	-	-	-

### 3.1.5 Example for Use of Standardised Test IDs for Misfire Monitor

OBD regulations require reporting the number of misfire events detected during the current driving cycle (Test ID \$0C) and the average number of misfire events detected during the last 10 driving cycles (Test ID \$0B) for each cylinder. Therefore, for a 4-cylinder engine, eight pieces of data must be reported for both Test IDs.

The purpose of the misfire data is to help identify which cylinders are currently misfiring (\$0C) and identify which cylinders have been consistently misfiring in the past 10 driving cycles (\$0B). The actual misfire event counts will depend on how the vehicle was driven, how long it was driven, etc. Misfire counts for cylinders are only to be compared relative to each other. If some cylinders have many more misfire events than other cylinders, troubleshooting should begin with the cylinders that have the highest number misfire events.

The Test ID \$0B registers contain the EWMA (Exponential Weighted Moving Average) value for misfire events counted during the last 10 driving cycles. The EWMA value is only re-calculated once per driving cycle. This calculation is done every power-down sequence due to the control module having a short stay alive period after the ignition key is turned off. The EWMA value uses the misfire event counts collected during the last/current driving cycle. The value of the \$0C counters, after the driving cycle ends, is the number of misfire events counted during the current/last driving cycle. The software takes the contents of the \$0B register (this is the previous average) multiply by 0.9 and adds the contents of the \$0C register (this is the current misfire event counts) multiplied by 0.1. This becomes the new EWMA value.

The Test ID \$0C counters counts misfire events for each cylinder and save them in Keep Alive or Non-Volatile Memory. They update continuously, in 200 or 1000 revolution increments, as a minimum. When the engine starts, the \$0C misfire counters are reset to zero. Prior to engine start-up, the last value from the previous driving cycle is retained, so that the number of misfire events that occurred during the last drive cycle can be displayed. If a vehicle has constant misfire in one or more cylinders, Test ID \$0C can be used to monitor the misfire event counters whilst the vehicle is being driven, up to a maximum of 65,535 events.

There are no minimum or maximum misfire monitor threshold limits for misfire counts. Test IDs \$0B and \$0C just accumulate the number of misfires that occur. These counts should accumulate with or without a misfire DTC. If there was a small misfire, but not enough to store a DTC, Test ID \$0B and \$0C values for each cylinder should still show the number of misfire events that occurred. The minimum test limit value should be 0; the maximum test limit value should be 65,535 so there will never be a "fail" result.



Standardised Test IDs for Misfire Monitor							
OBD MID	On-Board Diagnostic Monitor ID name	P Code	Test ID	Test ID Description	Min. Test Limit	Max. Test Limit	Unit & Scaling
A1	Misfire Monitor General Data	P1316	93	Excess Emissions	0000	7FFF	24
		P1315	94	Catalyst damage	0000	FFFF	24
A2	Misfire Cylinder 1 Data		OB	Exponential Weighted Moving Average for Cylinder #1	0000	FFFF	24
			OC	Stored misfire event during last/current drive cycle for Cylinder #1	0000	FFFF	24
A3	Misfire Cylinder 2 Data		OB	Exponential Weighted Moving Average for Cylinder #2	0000	FFFF	24
			OC	Stored misfire event during last/current drive cycle for Cylinder #2	0000	FFFF	24
A4	Misfire Cylinder 3 Data		OB	Exponential Weighted Moving Average for Cylinder #3	0000	FFFF	24
			OC	Stored misfire event during last/current drive cycle for Cylinder #3	0000	FFFF	24
A5	Misfire Cylinder 4 Data		OB	Exponential Weighted Moving Average for Cylinder #4	0000	FFFF	24
			OC	Stored misfire event during last/current drive cycle for Cylinder #4	0000	FFFF	24
A6	Misfire Cylinder 5 Data		OB	Exponential Weighted Moving Average for Cylinder #5	0000	FFFF	24
			OC	Stored misfire event during last/current drive cycle for Cylinder #5	0000	FFFF	24
A7	Misfire Cylinder 6 Data		OB	Exponential Weighted Moving Average for Cylinder #6	0000	FFFF	24
			OC	Stored misfire event during last/current drive cycle for Cylinder #6	0000	FFFF	24

## **4 Onboard Monitoring**

### **4.1 Catalyst Monitoring**

#### **4.1.1 Description**

The Catalyst monitor operates once per trip. It waits until all entry conditions are met.

Once all the entry conditions are met, the monitor will start to run. The fuelling is cycled rich and lean by approximately 3% to achieve a reaction at the downstream exhaust gas oxygen sensor, this process is called dither. At the start of any monitoring period, a short delay ( steady state condition check) will occur before the monitor is enabled to ensure that the fuelling is stable when the diagnosis takes place. If for any reason, the entry conditions are no longer valid, but the monitor has not yet completed then the result and execution time data are retained. If the entry conditions are again fulfilled, the monitor will resume with the stored data, unless there have been more than four attempts to run the check, in which case the monitor will clear the accumulated data and restart the diagnosis.

After the monitor has run for a calibrated period of time, the results are calculated. These are determined by accumulating the locus of the downstream exhaust gas oxygen sensor signal against the accumulation of the upstream exhaust gas oxygen sensor. I.e. the more active the downstream sensor, the less oxygen storage capacity the catalyst has, resulting in a correspondingly higher locus value. With a correctly operating catalyst, the downstream sensor is not so active, so lower locus values are obtained than would be recorded with a faulty system.

If the accumulated count is lower than a calibratable threshold then the catalyst diagnostic test has been passed. If the accumulated count equals or exceeds the calibratable threshold then the catalyst system has a problem and the appropriate DTC will be stored.

## 4 Onboard Monitoring

### 4.1 Catalyst Monitoring

#### 4.1.1 Description

The Catalyst monitor operates once per trip. It waits until all entry conditions are met.

Once all the entry conditions are met, the monitor will start to run. The fuelling is cycled rich and lean by approximately 3% to achieve a reaction at the downstream exhaust gas oxygen sensor, this process is called dither. At the start of any monitoring period, a short delay ( steady state condition check) will occur before the monitor is enabled to ensure that the fuelling is stable when the diagnosis takes place. If for any reason, the entry conditions are no longer valid, but the monitor has not yet completed then the result and execution time data are retained. If the entry conditions are again fulfilled, the monitor will resume with the stored data, unless there have been more than four attempts to run the check, in which case the monitor will clear the accumulated data and restart the diagnosis.

After the monitor has run for a calibrated period of time, the results are calculated. These are determined by accumulating the locus of the downstream exhaust gas oxygen sensor signal against the accumulation of the upstream exhaust gas oxygen sensor. I.e. the more active the downstream sensor, the less oxygen storage capacity the catalyst has, resulting in a correspondingly higher locus value. With a correctly operating catalyst, the downstream sensor is not so active, so lower locus values are obtained than would be recorded with a faulty system.

If the accumulated count is lower than a calibratable threshold then the catalyst diagnostic test has been passed. If the accumulated count equals or exceeds the calibratable threshold then the catalyst system has a problem and the appropriate DTC will be stored.

### 4.1.2 Monitoring Structure

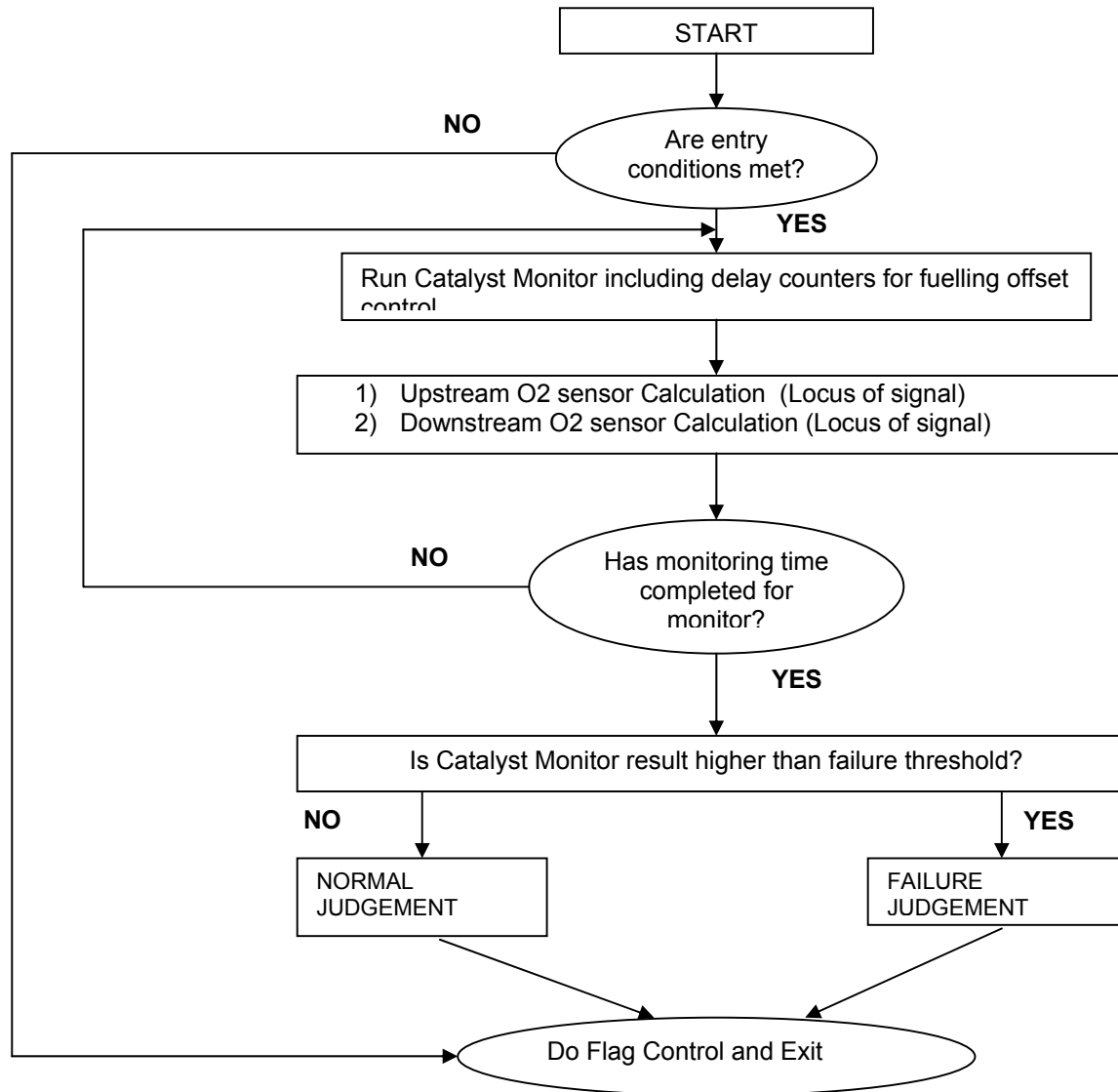

Catalyst Monitoring Operation								
Component/ System	Fault Codes	Monitoring Strategy Description	Malfunction Criteria	Threshold value	Secondary Parameter	Enable Conditions	Time Required	MIL
Catalyst efficiency bank 1 Catalyst efficiency bank 2	P0420  P0430	Upstream O2 sensor signal locus compared to downstream O2 sensor signal locus during air/fuel dither	Locus ratio	>= TBC	Engine speed ECT MAF Engine speed change Throttle position change Mass airflow change Atmospheric pressure Sub feedback control Short term air/fuel trim Closed loop air/fuel control + sub feedback control Idle  Disabled DTCs	1300 < RPM < 3250 rpm >= 75 °C 10 < MAF < 65 g/sec <= 360 rpm <= 1) % per second <= 30 g/sec in 512 msec >=70 kPa 0.975 to 1.025 0.8 to 1.2 Active  Inactive  P2096 P2097 P2098 P2099	30 s	2 drive cycles

If the above table does not include details of the following enabling conditions: - IAT, ECT, vehicle speed range, and time after engine start-up then the state of these parameters has no influence upon the execution of the monitor.

#### 4.1.3 Drive Cycle Information

1. Start engine and bring to normal operating temperature > 75 °C (167 °F).
2. With the gear selector in Park or Neutral, hold the engine speed at 2500 rpm for 5 minutes.
3. Drive vehicle ensuring that vehicle speed exceeds 15 km/h (10 mph) and the engine speed exceeds 1500 rpm.
4. Stop the vehicle and check for any temporary DTCs.

## 4.2 Misfire Monitoring

### 4.2.1 Description

The misfire detection monitor runs continuously and is designed to detect levels of misfire that can cause thermal damage to the catalyst or result in excessive tailpipe emissions. Determination of a misfire is made by analysis of changes in crankshaft speed, since a misfire will cause a fall in speed after a faulty firing event. This data is analysed in four ways to ensure the detection of all possible combinations of misfire.

The results of the misfire judgement process for each firing event are used to determine whether two failure levels have been met, 'catalyst damage' misfire and 'excess emissions' misfire. Each fault judgement process has its own failure threshold and calculation period.

The following fault conditions can be identified by the monitor

- Cylinder 1 (1A) misfire
- Cylinder 2 (1B) misfire
- Cylinder 3 (2A) misfire
- Cylinder 4 (2B) misfire
- Cylinder 5 (3A) misfire
- Cylinder 6 (3B) misfire
- Catalyst damage misfire
- Excess emissions misfire
- Low fuel level misfire
- Multiple cylinder misfire

The misfire monitor operates continuously within the boundaries of the regulated monitor operation window, as shown below.

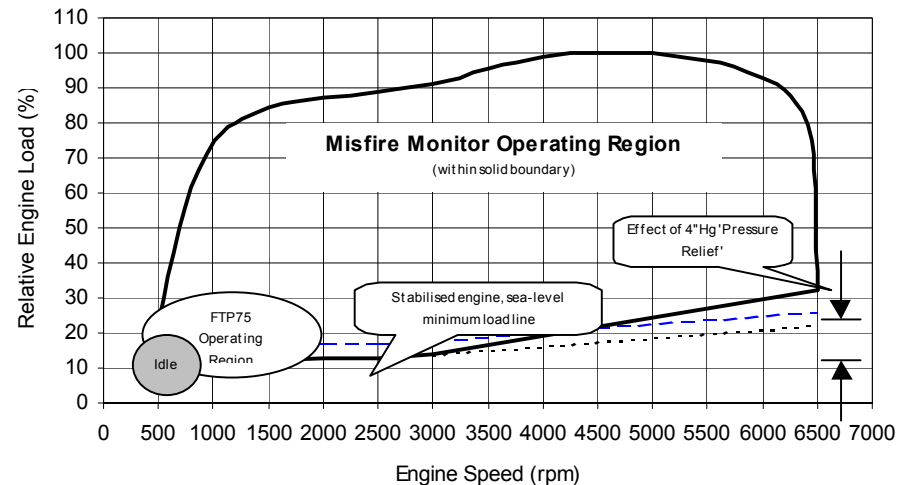

After engine start, the monitor will be enabled as soon as the engine speed rises above the minimum operation speed (150 rpm below fully warm stabilised idle speed). Two revolutions of crank angle data, i.e. One sample of data from each cylinder firing, must then be 'buffered' before any decisions can be made by the monitor. Before engine speed has reached the top of the start flare the monitor will be ready to make misfire judgments, which are then made on every cylinder firing, irrespective of whether the monitor is enabled or not.

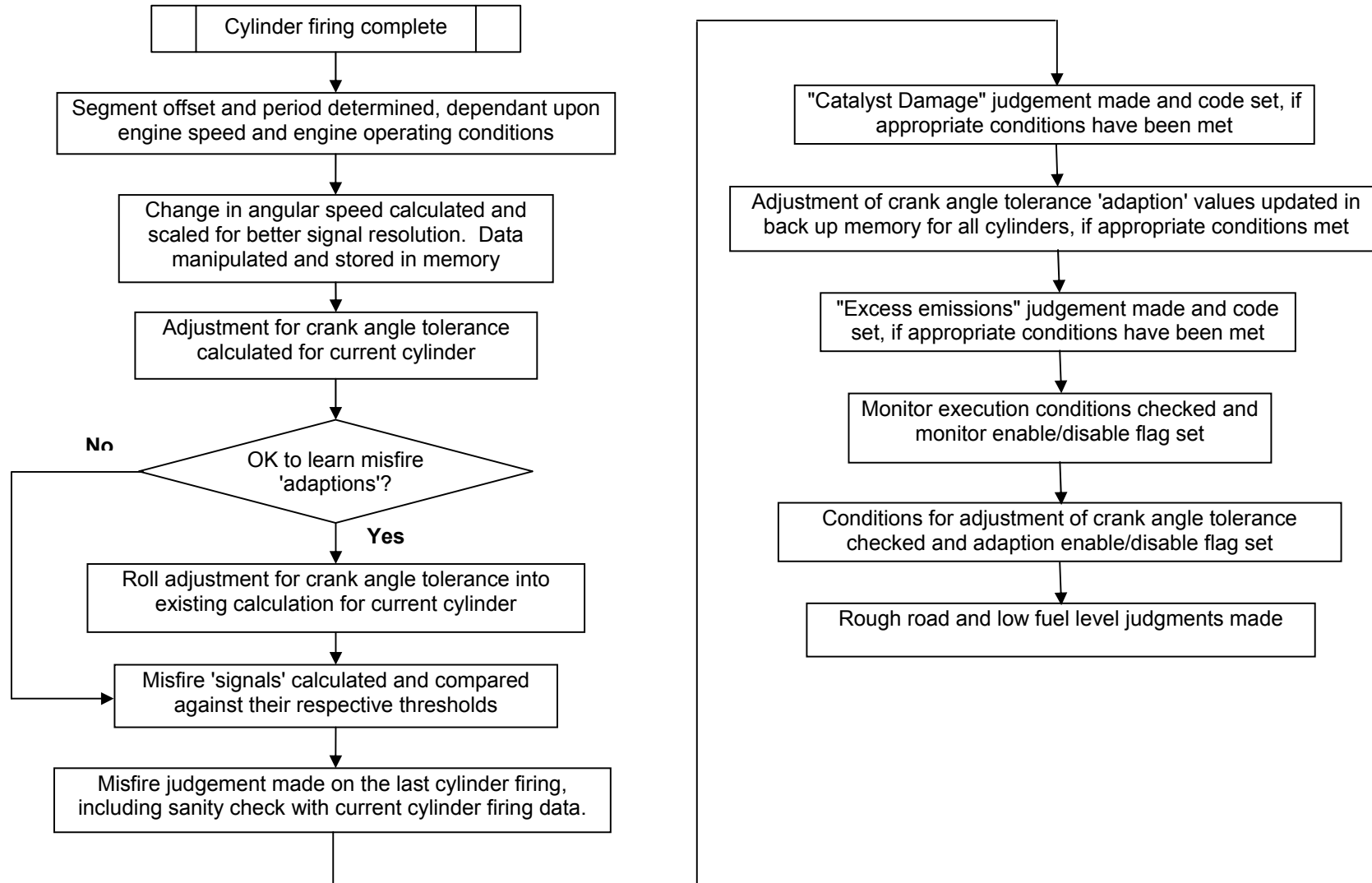

## 4.2.2 Strategy Description

### Introduction

Different sections of the monitor operate at different 'loop' rates. The flow chart above details the decisions made for each firing event in approximate chronological order, although some steps may not be made every 'loop'. Further explanation of these decisions is given below:

### Recording segment time and position, and its manipulation

The monitor records crank angle time data every 30° of rotation with a 250 nanosecond measurement accuracy. Each 30° period is known as a 'segment'. The starting point of the segments relative to TDC firing and the number of segments used can be defined for each application so as to give the best and most robust probability of misfire detection. To maintain good detection across the entire engine speed range the measurement period can be altered between low and high engine speeds. The engine speed, at which the measurement period is altered, if any, is determined by experiment.

Additionally, a third measurement period is defined for detection during start-up and when catalyst warm up ignition retard is being used after engine start.

The angular speed of the crankshaft during the ignition stroke is calculated using the segment data, multiplied by a scaling factor for easier storage in the ECM's memory, manipulated further and stored for each cylinder firing,

### Adjustment of crank angle tolerance

Calculations are made using the stored data to generate an adaptive misfire 'signal'. Errors in the crank angle time data (for example, due to manufacturing tolerances) are calculated for each cylinder individually at pre-determined engine speed breakpoints. Compensating for these errors reduces the variation in amplitude of the misfire signal.

The data is gathered during normal combustion, requiring strict entry conditions to ensure robust adaptations. Adaption values are rolled in to a temporary calculation for the current speed breakpoint.

### Misfire 'signal' calculation

Where calculated adaption values have been stored in memory the adaptive signal will be calculated. This signal generally has the best opportunity to detect. However, the signal requires data in each speed breakpoint to interpolate between. If there is a breakpoint where no adaptations have been stored then the adaptive signal will only be used for misfire judgements up to the breakpoint immediately below it. For example if there is adaption data stored in memory up to 2000 rpm but none at 2500 rpm the adaptive signal will only be used up to 2000 rpm.

To support detection across the entire engine speed range further misfire 'signals' are calculated. These signals are not adjusted for errors in crank angle tolerance. These signals typically give good probability of detection at low engine speeds but become less effective at higher engine speeds.



## Misfire judgement

Misfire judgements are delayed by one firing cycle. This is to allow comparison of the signal with the cylinders that fire before and after it, eliminating 'noisy' signals. Should the monitor repeatedly eliminate the signal over 5 consecutive firings on the same cylinder the monitor will assume that two adjacent cylinders are misfiring, ignore the signal check and allocate the 5 eliminated misfire judgements to the appropriate cylinder.

Adapted and un-adapted signals are compared to their respective thresholds in series. The diagram below illustrates the behaviour of the 'adaptive' misfire signal with 1.0% intermittent misfire applied (data taken from a typical 8 cylinder application) and its judgement threshold.

Should one signal cross the threshold, indicating a misfire, the other methods will be skipped in order to prevent multiple counting of the same misfire event.

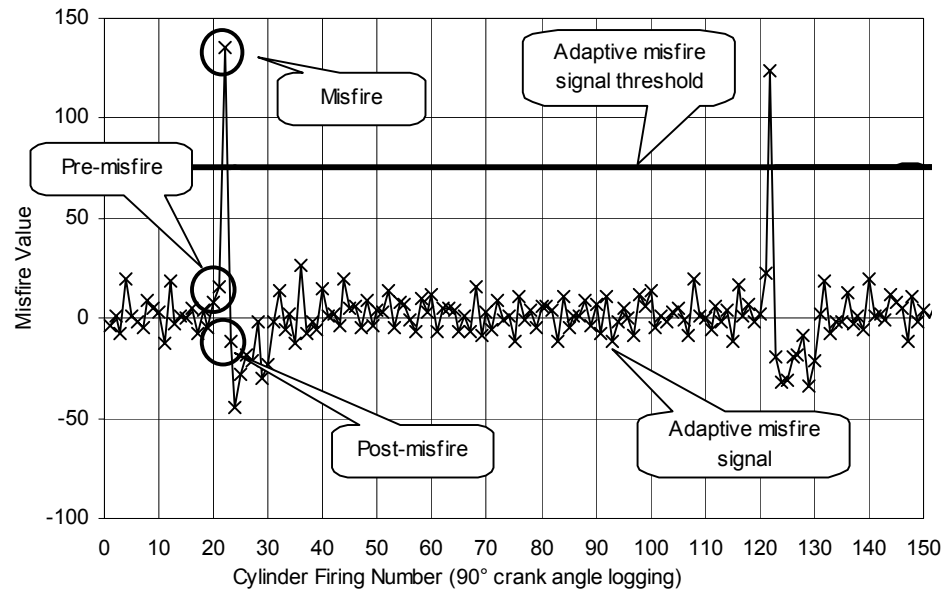

Adaptive signal characteristic with intermittent misfire

## Catalyst damage judgement

If 200 revolutions of misfire judgements have been made the monitor will make an assessment as to whether 'catalyst damage' levels of misfire have been exceeded or not. The failure level is determined from a look up table. The sum of individual cylinder misfire counters is then compared against this threshold. If the failure threshold is exceeded then the MIL will illuminate and the appropriate DTCs will be stored.

### **Storing adaption values in back-up memory**

If no misfires have been recorded for the last 'catalyst damage' judgement, and sufficient temporary adaption calculations have been made, the temporary adaption data calculated for each cylinder will be stored in 'back-up' memory, for the appropriate engine speed breakpoint.

If a single misfire is counted for the last 'catalyst damage' judgement, all temporary adaption data will be reset, along with the temporary calculation.

Once data has been stored in memory it can be updated but will not be erased, even after a battery reset.

### **Excess emissions judgement**

If 1000 revolutions of misfire judgements have been made the monitor will make an assessment as to whether 'emissions failure' levels of misfire have been exceeded or not. The failure level is a single threshold value. The sum of individual cylinder misfire counters is compared against this threshold. If the failure threshold is exceeded then the MIL will illuminate and the appropriate DTCs will be stored.

### **Monitor execution check**

Different monitor enable conditions are checked depending upon the operating condition of the engine (for example, fewer conditions apply during engine start). If all the appropriate enable conditions are met the monitor execution flag is set.

### **Adaptive learning execution check**

Specific operating conditions, required for learning misfire 'adaption' values, are checked and the adaption execution flag set as appropriate.

### **Rough road and low fuel level judgement**

A rolling average of 'delta' wheel speed data is calculated from ABS vehicle speed data that is transmitted over the CAN network. This data is compared to calibrated thresholds to determine if the vehicle is being driven over a rough surface that causes misdiagnosis of a misfire. If a rough road judgement is made the appropriate flag is set and taken into account the next time monitor execution conditions are checked.

An additional fault code is stored alongside the misfire fault codes if the fuel level is below a calibratable level. This is to indicate that a possible cause of the misfire fault codes was low fuel level.

It is also possible to block the output of misfire fault codes for low fuel level so long as the on board diagnostic system has not detected a fuel level signal fault. Again this is calibratable and is not used in all applications.

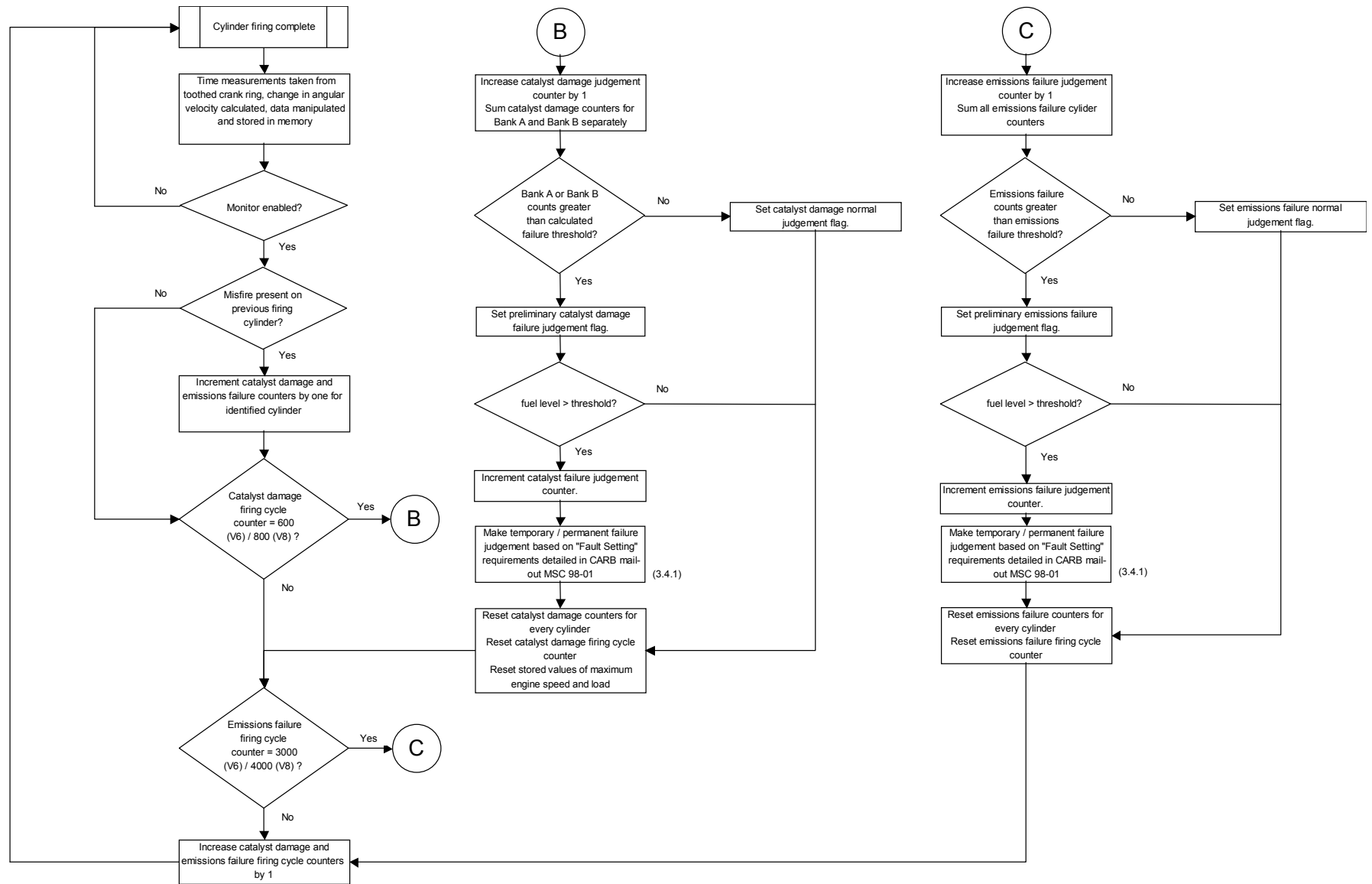

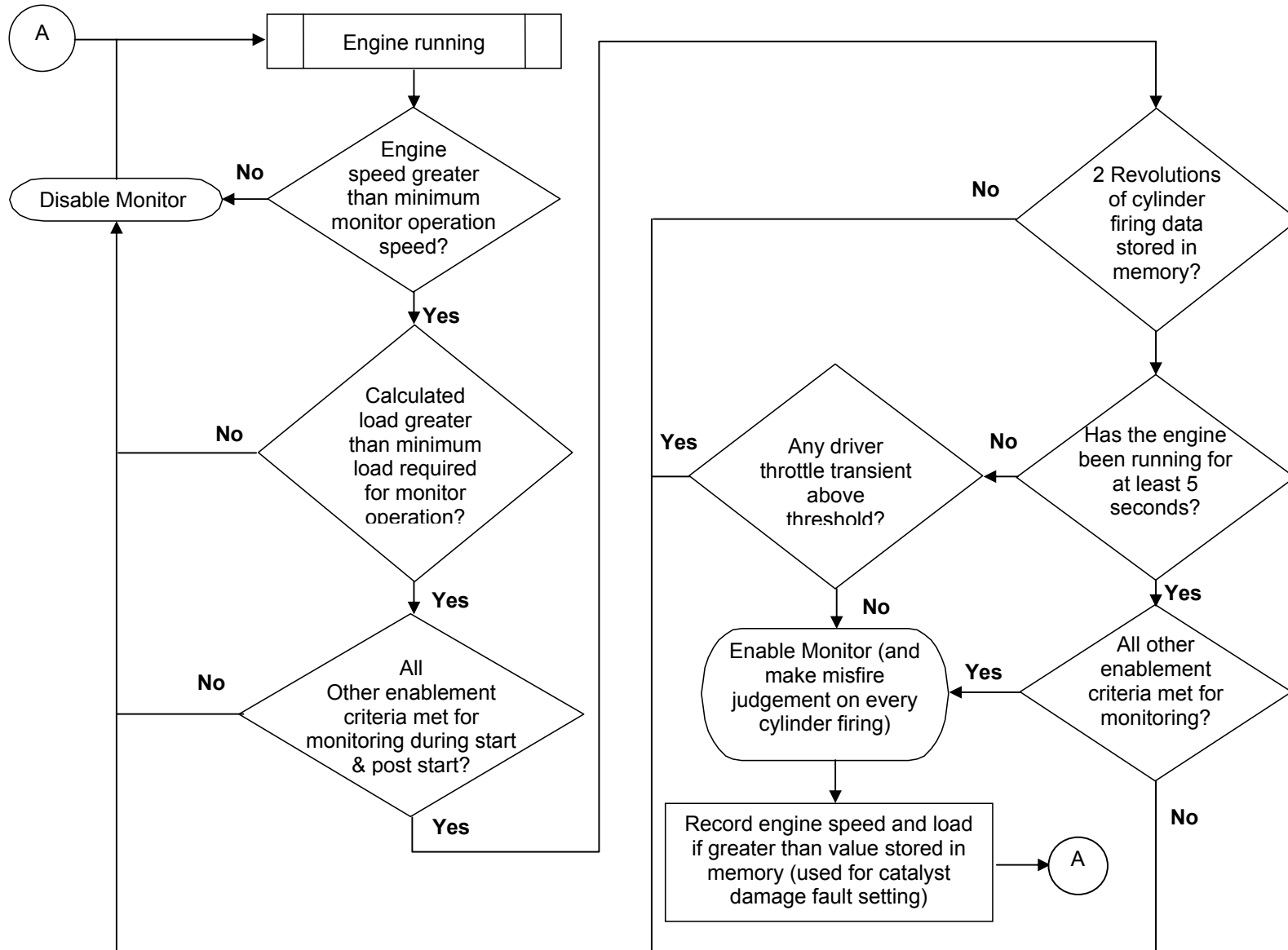

Misfire Monitoring Operation								
Component/ System	Fault Codes	Monitoring Strategy Description	Malfunction Criteria	Threshold value	Secondary Parameter	Enable Conditions	Time Required	MIL
Misfire Monitoring		Crankshaft speed fluctuations			Engine speed	>= 550 rpm		
Random misfire	P0300		Misfire above catalyst damage or emissions level		Engine coolant temperature	> - 8.1 °C		
Misfire cylinder 1	P0301		Misfire above catalyst damage or emissions level		Ambient air temperature	> - 40 °C		
Misfire cylinder 2	P0302		Misfire above catalyst damage or emissions level		Atmospheric pressure	> 68 kPa		
Misfire cylinder 3	P0303		Misfire at catalyst damage or excessive emissions level		Fuel level	>= 3%		
Misfire cylinder 4	P0304		Misfire above catalyst damage or emissions level		Engine load	Zero torque with pressure relief above 3000 rpm		
Misfire cylinder 5	P0305		Misfire above catalyst damage or emissions level		Engine speed delta	< 250 rpm in 64 msec		
Misfire cylinder 6	P0306		Misfire above catalyst damage or emissions level		Engine load delta	< 0.25 g/rev in 64 msec		
					Throttle angle delta	< 1.56 %		
					Fuel cut off	20 firings after last active		
					Rough road	512 ms after last active		
Misfire catalyst damage	P1315		Misfire at catalyst damage level (200 revolution block)	> Map 1	Slip control activity	20 firings after last active		
Misfire excess emissions	P1316		Misfire at excess emissions level (1000 rev block)	> 69				
Misfire during first 1000 revs	P0316		Misfire during first 1000 engine revolutions after start.					
Misfire low fuel level	P0313		Misfire above catalyst damage or emissions level	<= 5.00 %				
					Disabled fault codes	P0101 P0106 P010B P0125 P0128 P0133 P0140 P0153 P0160 P2096 P2097 P2098 P2099 P0420 P0430		

If the above table does not include details of the following enabling conditions: - IAT, ECT, vehicle speed range, and time after engine start-up then the state of these parameters has no influence upon the execution of the monitor.

### Map 1

Misfire Catalyst damage levels															
x-axis units y-axis units Data units	rpm g/rev %														
	550	730	1000	1500	2000	2500	3000	3500	4000	4500	5000	5500	6000	6500	7000
0.25	50	50	45	43	42	39	35	33	33	27	25	24	24	23	21
0.30	46	46	42	40	40	37	33	31	31	25	23	22	22	21	19
0.40	42	42	40	37	36	33	30	28	28	21	20	19	19	17	16
0.60	40	40	39	39	34	31	27	23	22	19	18	16	15	14	14
0.90	39	39	37	33	28	24	20	18	17	16	13	11	10	9	9
1.20	31	31	31	25	22	19	19	17	17	13	11	7	8	8	8
1.30	28	28	28	26	21	20	17	14	15	9	9	8	9	8	8
1.60	33	33	33	26	24	23	17	15	19	17	14	12	13	13	13

### 4.2.3 Drive Cycle Information

- 1 Record flagged DTC(s) and accompanying DTC Monitor freeze frame(s) data.
- 2 Fuel level > 5%.
- 3 Start the engine at a coolant temperature lower than the recorded freeze frame value (from Step 1).
- 4 Drive the vehicle to the recorded freeze frame conditions for 4 minutes. If CHECK ENGINE MIL flashes, lower the engine speed until the flashing stops.

Note regarding misfire monitor DTCs:

If, on the first trip, the misfire is severe enough to cause excess exhaust emission, the individual cylinder DTC will be logged. The CHECK ENGINE MIL will not be activated. If the fault reoccurs on the second trip, the individual cylinder DTC will be flagged, and the CHECK ENGINE MIL will be activated. If a misfire is detected on start up (within the first 1000 revolutions) the DTC P0316 will also be flagged.

If, on the first trip, the misfire is severe enough to cause catalyst damage (more severe than excess exhaust emission), the CHECK ENGINE MIL will flash while the fault is present and the individual cylinder DTC will be logged. When the fault is no longer present, the MIL will be deactivated. If the fault reoccurs on the second trip, the CHECK ENGINE MIL will flash while the fault is present and the individual cylinder DTC will be flagged. When the fault is no longer present, the CHECK ENGINE MIL will be activated.

If a misfire DTC is recorded when the fuel level is less than 15%, the DTC P0313 will be recorded.

### 4.3 Evaporative Emission System Monitoring

#### 4.3.1 Schematic

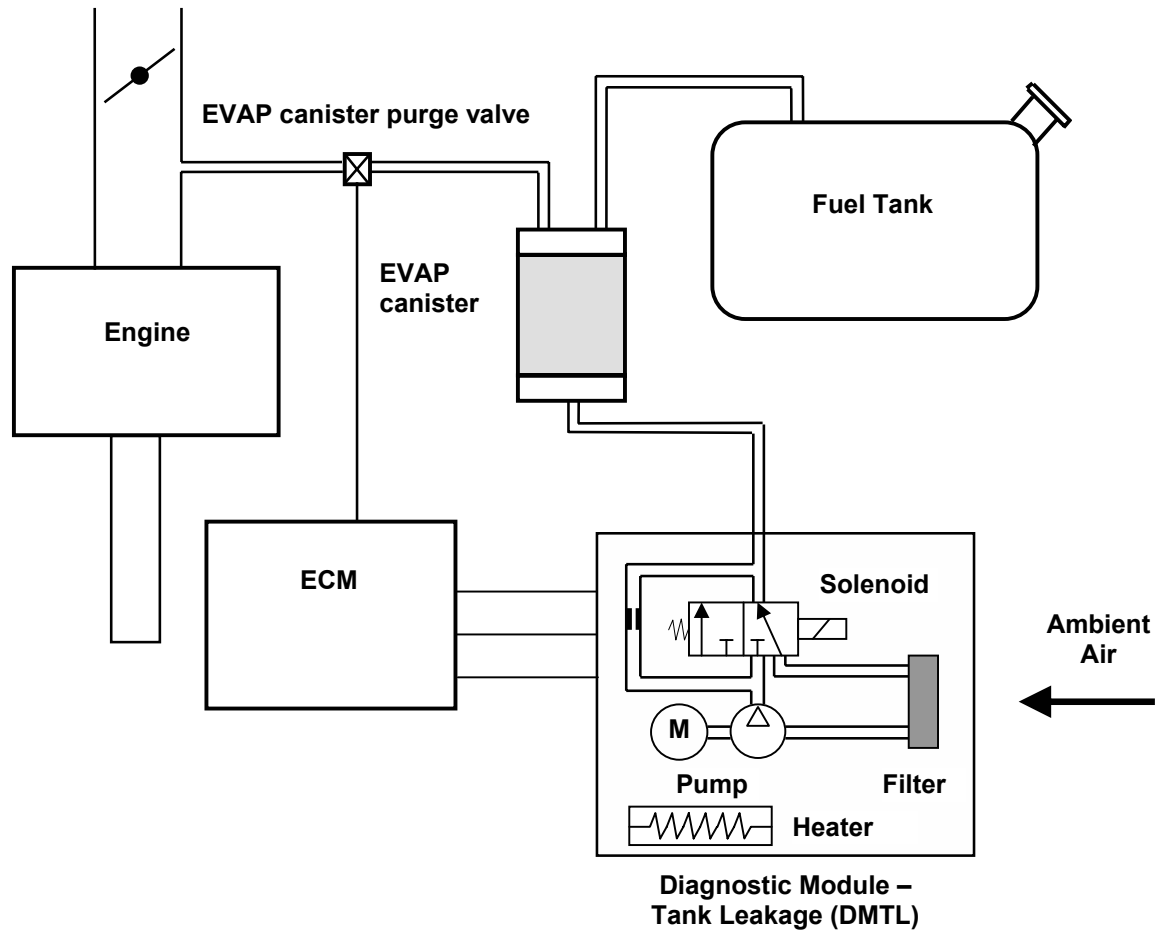

### 4.3.2 Description

The evaporative monitoring system being used permits the detection of leaks with a diameter of 0.5 mm (0.020") or greater.

This is achieved by means of a pressure test of the system. This is performed by the Diagnostic Module - Tank Leakage (DMTL), which is an electrically operated pump fitted to the atmospheric air intake of the EVAP canister.

The test proceeds in 2 stages:

- Reference Leak Measurement - The pump operates against the reference restriction within the DMTL. The Engine Control Module measures the current consumption of the pump motor during this phase.
- Leak Measurement - The solenoid in the DMTL is operated in order to shut off normal purge airflow into the EVAP canister. The pump can now pressurise the fuel tank and vapour handling system. The Engine Control Module again measures the current consumed by the pump motor and by comparing this with the reference current, determines if a leak is present or not. A high current indicates a tight system and a low current indicates a leaking system.

#### Fault Conditions That Can Be Identified

- Reference current high
- Reference current low
- Reference leak
- Noise fault
- Change over valve stuck open
- Change over valve stuck closed
- Rough leak (0.040" or larger)
- Small leak (0.020" or larger)
- Pump electrical high
- Pump electrical low
- Change over valve electrical high
- Change over valve electrical low
- Pump heater high
- Pump heater low



### 4.3.3 Typical monitoring results

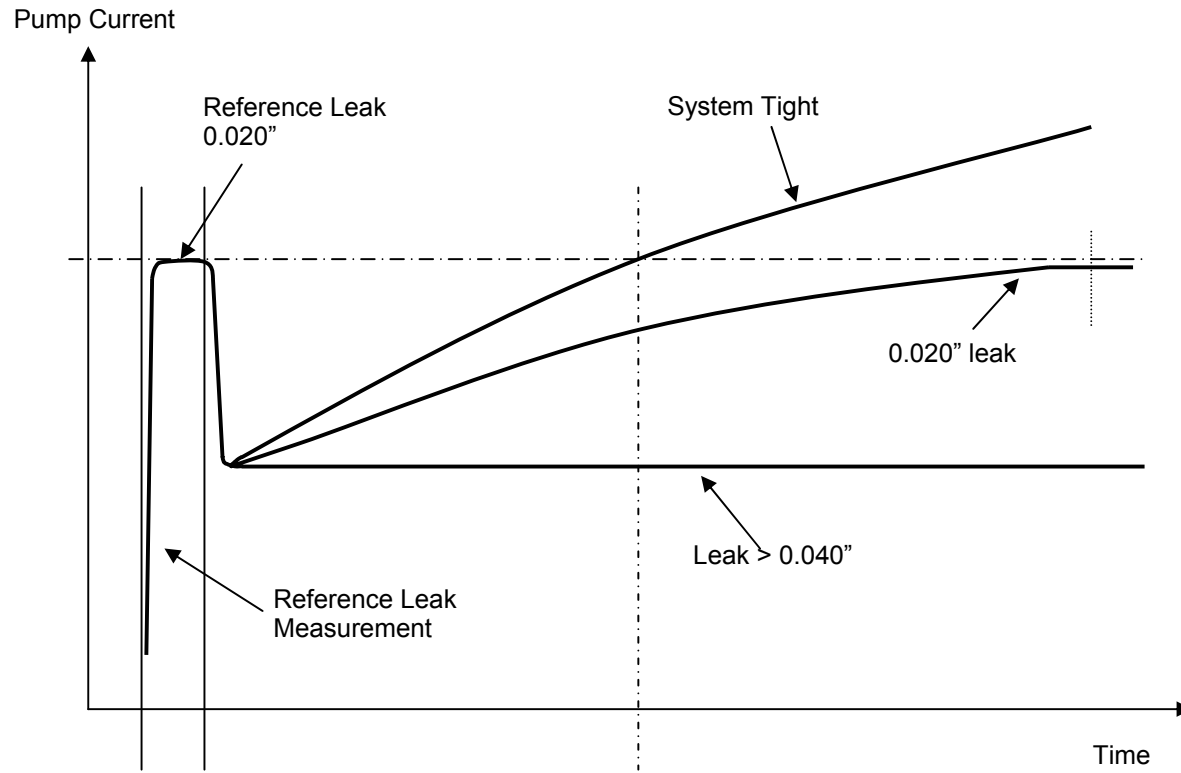

### 4.3.4 Strategy Flowchart

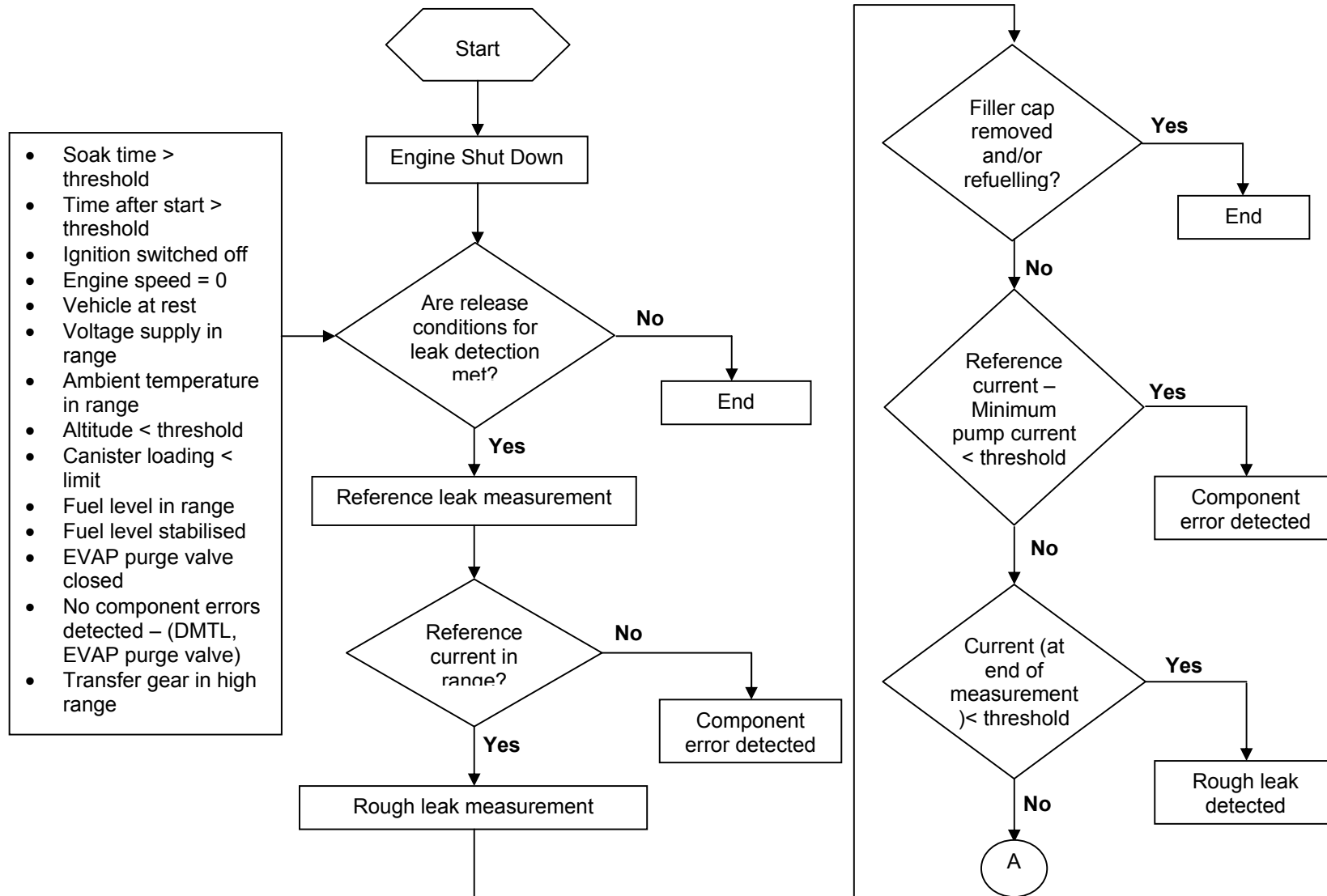

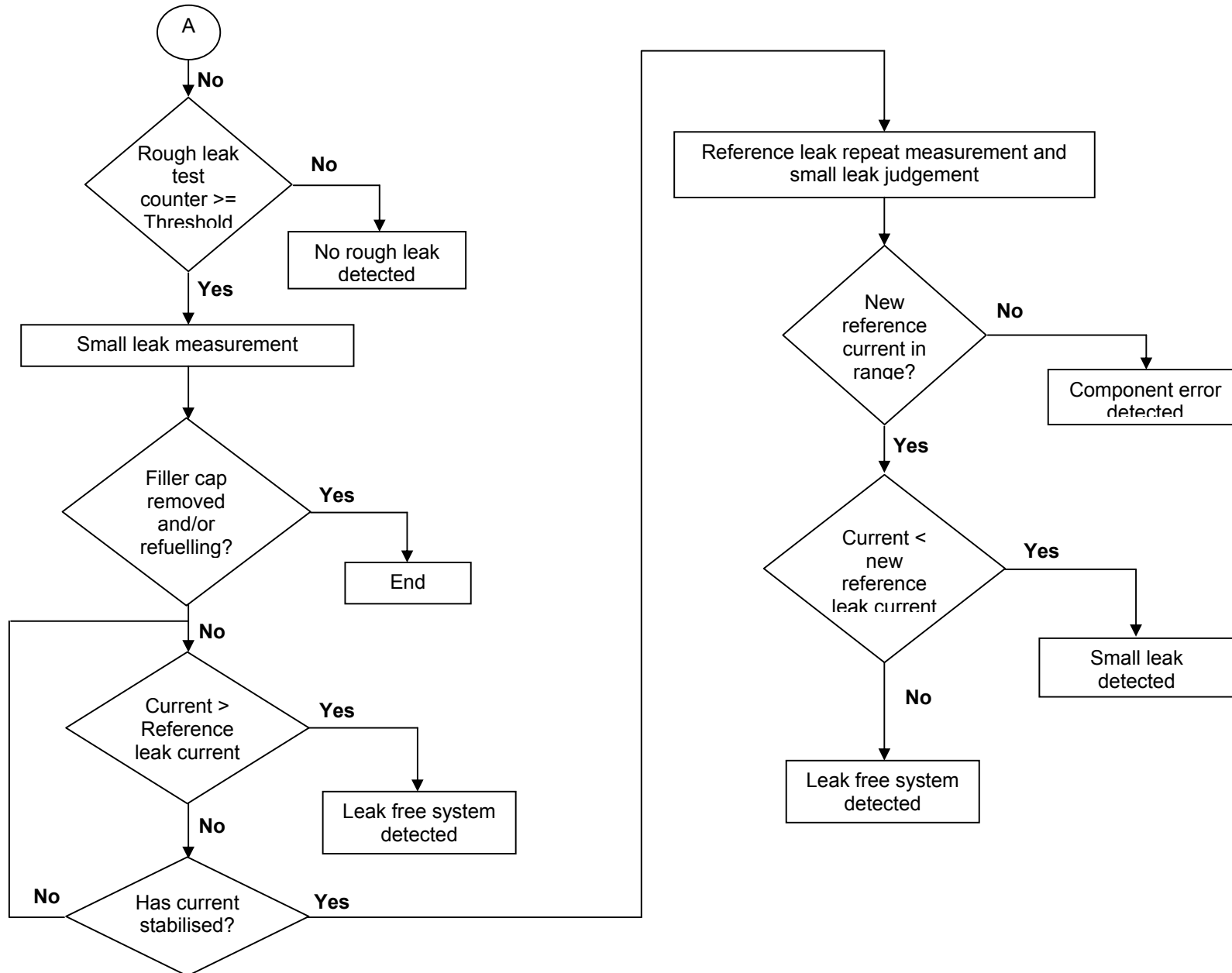

### 4.3.5 Evaporative Emission Canister Purge Valve

The purge flow monitor works continuously and is designed to detect low purge flow caused by a blockage in the purge system or a malfunctioning EVAP canister purge valve.

The basis of the diagnostic is to detect the presence of intake pressure pulses caused by the 10 Hz pulse width modulated control of the EVAP canister purge valve duty (as shown in figure 1 below).

A discrete Fourier transform (DFT) calculation is used to help distinguish these pulses from other noises present in the intake pressure signal.

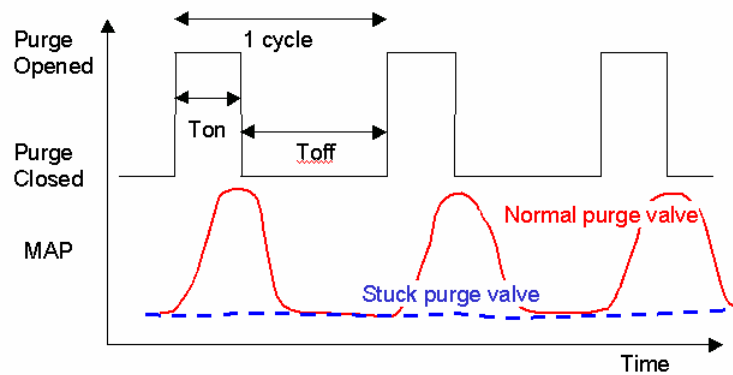

#### Purge operation

### 4.3.6 Purge Flow Strategy Flowchart

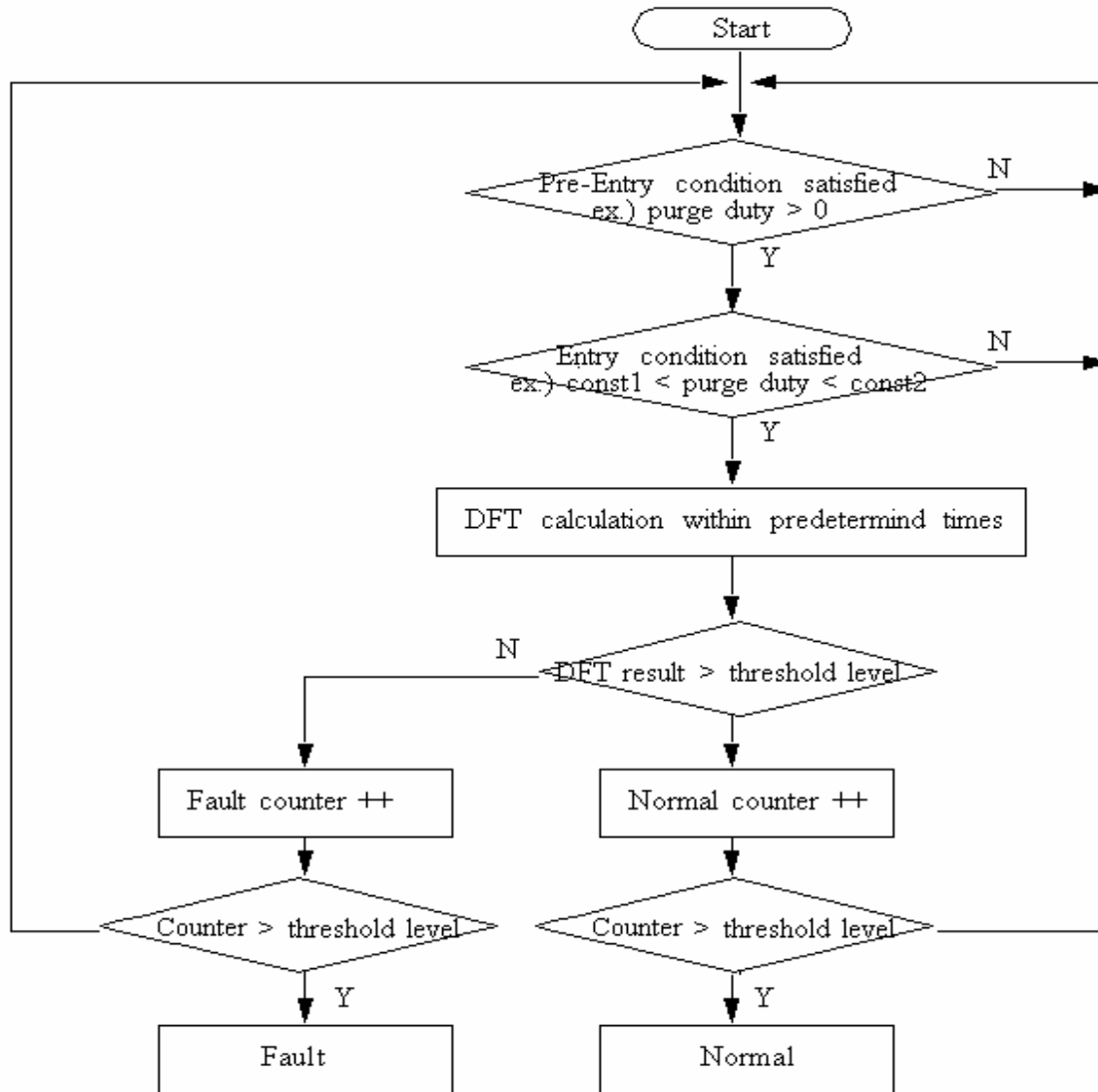

Evaporative Emission System Monitoring								
Component/ System	Fault Codes	Monitoring Strategy Description	Malfunction Criteria	Threshold value	Secondary Parameter	Enable Conditions	Time Required	MIL
<b>Fuel evaporative leak monitoring</b>		Pressure test of system using ECM driven pump					See Map 8	
Rough leak	P0442		(pump current – minimum current)/(reference current – minimum current) ratio at end of rough leak measurement time	< Map 2	Soak time	> 180 minutes		2 drive cycles
Small leak	P0456		Pump current / reference leak current ratio when pump current has stabilized or pump current threshold below table 12	< 1.0508 or Table 12	Ignition switch Engine speed	Off 0 rpm		2 drive cycles
Reference current high (pump hardware fault)	P2406		Reference leak current	> 38 mA	Vehicle speed	< 1.25 mph		2 drive cycles
Reference current low (pump hardware fault)	P2405		Reference leak current	< 12 mA	Voltage supply	10 < B+ < 15 V		2 drive cycles
Change over valve stuck open (pump hardware fault)	P2450		Pump current delta at change over valve close point (for pump current <= reference leak current)	> 2.0 mA	Ambient air temperature	0 to 40 °C		2 drive cycles
Change over valve stuck closed (pump hardware fault)	P2451		Pump current delta at change over valve close point (for pump current <= reference leak current)	> 1984 msec	Atmospheric pressure	> 70 kPa		2 drive cycles
Reference leak (pump hardware fault)	P2404		Time taken for pump current stabilisation during reference leak measurement	> 60 sec	Canister loading	< 2.50		2 drive cycles

Evaporative Emission System Monitoring								
Component/ System	Fault Codes	Monitoring Strategy Description	Malfunction Criteria	Threshold value	Secondary Parameter	Enable Conditions	Time Required	MIL
Noise fault (pump hardware fault)	P2404		Time taken for pump current stabilisation during small leak measurement	> 595 sec	Fuel level  Fuel level stabilisation Purge valve duty	15 to 85 %  Stabilised Closed		2 drive cycles
Pump heater high	P240C							2 drive cycles
Pump heater low	P240B							2 drive cycles
Pump electrical high	P2402							2 drive cycles
Pump electrical low	P2401							2 drive cycles
Change over valve electrical high	P0448							2 drive cycles
Change over valve electrical low	P0447							2 drive cycles
Disabled DTCs						P0441		

If the above table does not include details of the following enabling conditions: - IAT, ECT, vehicle speed range, and time after engine start-up then the state of these parameters has no influence upon the execution of the monitor.

**Table 12**

Small Leak Current ratio									
x-axis units	%	5	14	15	45	55	65	75	85
Data units	Ratio (unitless)	0.29	0.29	0.24	0.5	0.6	0.7	0.8	0.9

## Map 2

Rough Leak Current Ratios								
x-axis units	mA							
y-axis units	mA							
Data units	Ratio (unitless)							
	10	14	18	22	26	30	34	38
10	0.12	0.12	0.22	0.62	0.62	0.62	0.62	0.62
14	0.12	0.12	0.12	0.22	0.62	0.62	0.62	0.62
18	0.12	0.12	0.12	0.12	0.22	0.62	0.62	0.62
22	0.12	0.12	0.12	0.12	0.12	0.22	0.62	0.62
26	0.12	0.12	0.12	0.12	0.12	0.12	0.22	0.62
30	0.12	0.12	0.12	0.12	0.12	0.12	0.12	0.22
34	0.12	0.12	0.12	0.12	0.12	0.12	0.12	0.12
38	0.12	0.12	0.12	0.12	0.12	0.12	0.12	0.12

## Map 8

Rough Leak Time Required								
x-axis units	%							
y-axis units	kPa							
Data units	msec							
	15	25	35	45	55	65	75	85
65	200000	192832	185728	178560	171456	164288	157120	150016
70	200000	192832	185728	178560	171456	164288	157120	150016
75	200000	192832	185728	178560	171456	164288	157120	150016
80	200000	192832	185728	178560	171456	164288	157120	150016
85	200000	192832	185728	178560	171456	164288	157120	150016
90	200000	192832	185728	178560	171456	164288	157120	150016
95	200000	192832	185728	178560	171456	164288	157120	150016
100	200000	192832	185728	178560	171456	164288	157120	150016

## Evaporative Emission System Monitoring



Component/ System	Fault Codes	Monitoring Strategy Description	Malfunction Criteria	Threshold value	Secondary Parameter	Enable Conditions	Time Required	MIL
<b>EVAP Canister Purge Valve</b> Circuit continuity _ short to ground Circuit continuity – short to battery	P0458		Commanded v actual	Different				2 Drive Cycles
	P0459		Commanded v actual	Different				2 Drive Cycles
Low purge flow	P0441	Check for intake pressure pulsations caused by the 10 Hz  pulse width modulated control of the purge valve duty	Amplitude of 10 Hz intake pressure pulsations	< 0.0003 kPa  > 4 judgements	Ambient temperature EVAP canister purge valve duty cycle Intake manifold pressure delta Engine speed  Atmospheric pressure - intake pressure Accumulated pulsation samples Disabled DTCs	> -40 °C  0.04 < t < 0.07 sec  < 0.8 kPa  500 to 2500 rpm (N/A) 500 to 1000 rpm (S/C) > Table 11  = 250		2 Drive Cycles
						P0133 P0140 P0153 P0160 P0401 P0420 P0430 P0441		

If the above table does not include details of the following enabling conditions: - IAT, ECT, vehicle speed range, and time after engine start-up then the state of these parameters has no influence upon the execution of the monitor.

**Table 10**

Purge Valve Pressure Difference Versus Engine Speed								
<b>Engine Speed (rpm)</b>	0	1000	2000	3000	4000	5000	6000	7000
<b>Pressure (kPa)</b>	30	30	30	30	30	30	30	30

### 4.3.7 Drive Cycle Information

#### Evaporative system leak faults

1. Ensure that fuel filler cap is secure (minimum three clicks)
2. Ensure that fuel level is within the range of 15 > 85%
3. Ensure that normal "high range" gears are selected
4. Ensure that the ambient temperature signal is within the range of 0 > 40 °C (if not, a short drive may be necessary to overcome the filtering used in this signal)
5. Ensure that any other DTCs have been rectified (especially if they relate to the purge valve or DMTL heater) and then clear them from the CM memory
6. Leave the vehicle to stand undisturbed for at least 3 hours in an environment with ambient temperature within the range of 0 > 40 °C and atmospheric pressure above 70 kPa
7. Start the engine and allow to idle for at least 10 minutes
8. Switch the engine off and remove the key from the ignition switch
9. Allow the vehicle to stand undisturbed for at least 10 minutes
10. Switch the ignition back on, wait for 10 seconds, check for DTCs
11. If a small leak fault is being investigated this drive cycle will need to be repeated (rough leak check is every drive cycle, small leak check is every other drive cycle)

#### Purge valve & Purge flow faults

1. Ensure that the ambient temperature signal is above 0 °C (if not, a short drive may be necessary to overcome the filtering used in this signal)
2. Ensure that any other DTCs have been rectified and then clear them from the CM memory
3. Start the engine and allow to idle for at least 10 minutes
4. Stop / re-start the engine and allow to idle for a further 5 minutes
5. Check for DTCs

## 4.4 Fuel System Monitoring

### 4.4.1 Description

This diagnostic monitors the long-term adaptations of the fuel system. If these exceed calibrated thresholds for a calibratable time then an appropriate DTC will be recorded.

This monitor operates continuously provided the entry conditions have been met. Any of the components that make up the fuel system that are individually monitored, like the exhaust gas oxygen sensors, fuel pressure sensor and fuel delivery system, must also themselves be in working order with no faults. The general operation of the monitor is shown below.

### 4.4.2 Strategy Flowchart

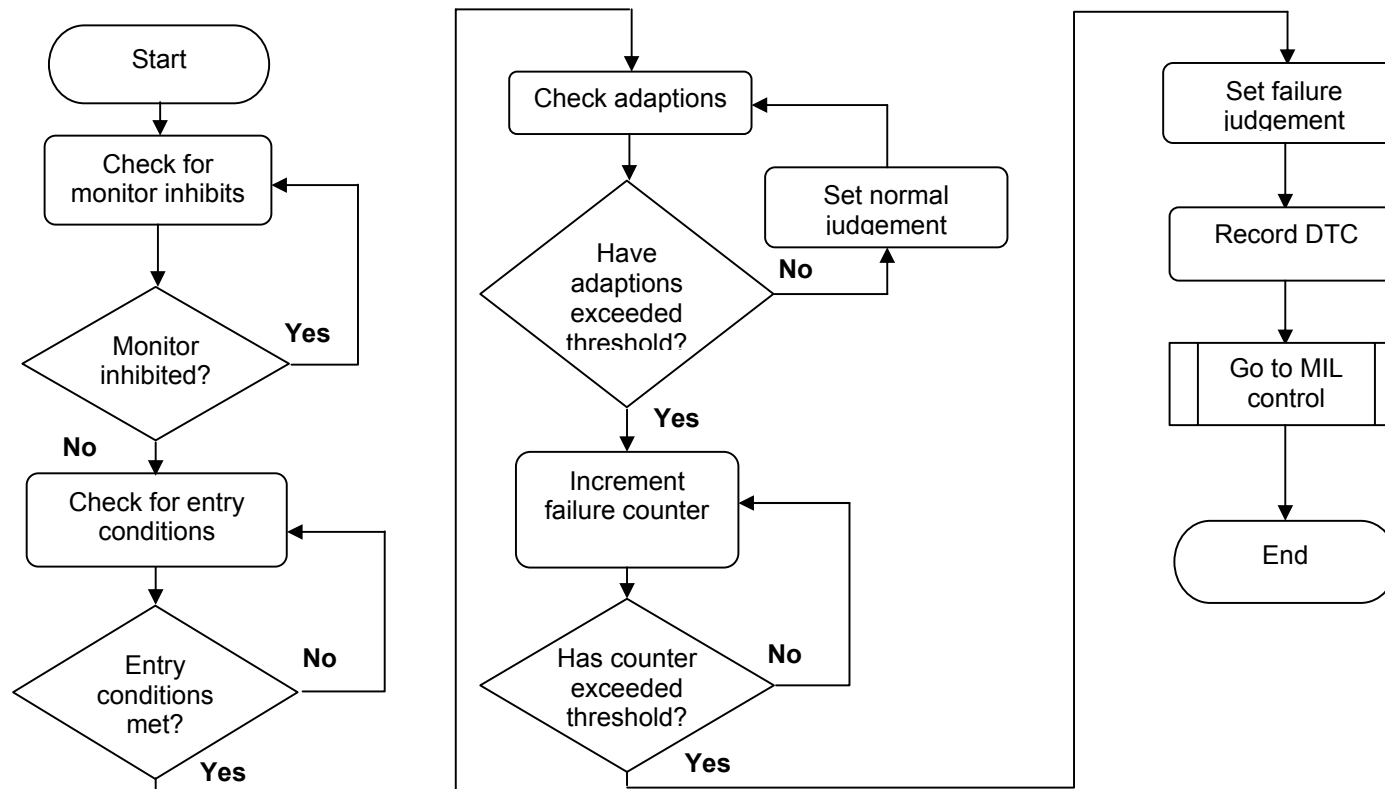

Fuel System Monitoring								
Component/System	Fault Codes	Monitoring Strategy Description	Malfunction Criteria	Threshold value	Secondary Parameter	Enable Conditions	Time Required	MIL
Fuel too lean – bank 1	P0171	Long term fuel trim values outside limits	Long term fuel trim	$\geq 1.19$	Time after start	$\geq 20$ sec	30 sec	2 drive cycles
Fuel too lean – bank 2	P0174				Engine speed	$\geq 550$ rpm	30 sec	2 drive cycles
Fuel too rich – bank 1	P0172		Long term fuel trim	$\leq 0.81$	Mass airflow	$\geq 4$ g/sec	30 sec	2 drive cycles
Fuel too rich – bank 2	P0175				Engine coolant temperature	$75 < ECT < 110$ °C	30 sec	2 drive cycles
<b>Secondary trim</b>					Disabled Fault Codes	P0128 P0133 P0140 P0153 P0160 P0420 P0430		
Sub feedback too lean bank 1	P2096	Sub feedback outside limits	Sub feedback trim value	$\geq 1.020$	Sub feedback	Executing	4	2 drive cycles
Sub feedback too lean bank 2	P2098							2 drive cycles
Sub feedback too rich bank 1	P2097		Sub feedback trim value	$\leq 0.955$			4	2 drive cycles
Sub feedback too rich bank 1	P2099							

If the above table does not include details of the following enabling conditions: - IAT, ECT, vehicle speed range, and time after engine start-up then the state of these parameters has no influence upon the execution of the monitor.

#### 4.4.3 Drive Cycle Information

1. Start engine and bring to normal operating temperature  $> 82$  °C (180 °F).
2. Idle for a minimum of 10 minutes.

## 4.5 Oxygen Sensor Monitoring

### 4.5.1 Upstream Oxygen Sensor High Low Monitor

This monitor is designed to detect continuous and intermittent faults with the upstream oxygen sensor signals. The monitor will operate continuously provided the entry conditions are met and the monitor is not inhibited for any of the reasons listed in the table.

The upstream oxygen sensors current, voltage and impedance are compared to failure thresholds. If the signals are higher or lower than a pre-defined amount, a timer is started. A continuous fault flag is set if the timer exceeds a threshold. Otherwise a normal flag is set.

A general flowchart of the operation of the monitor is shown below.

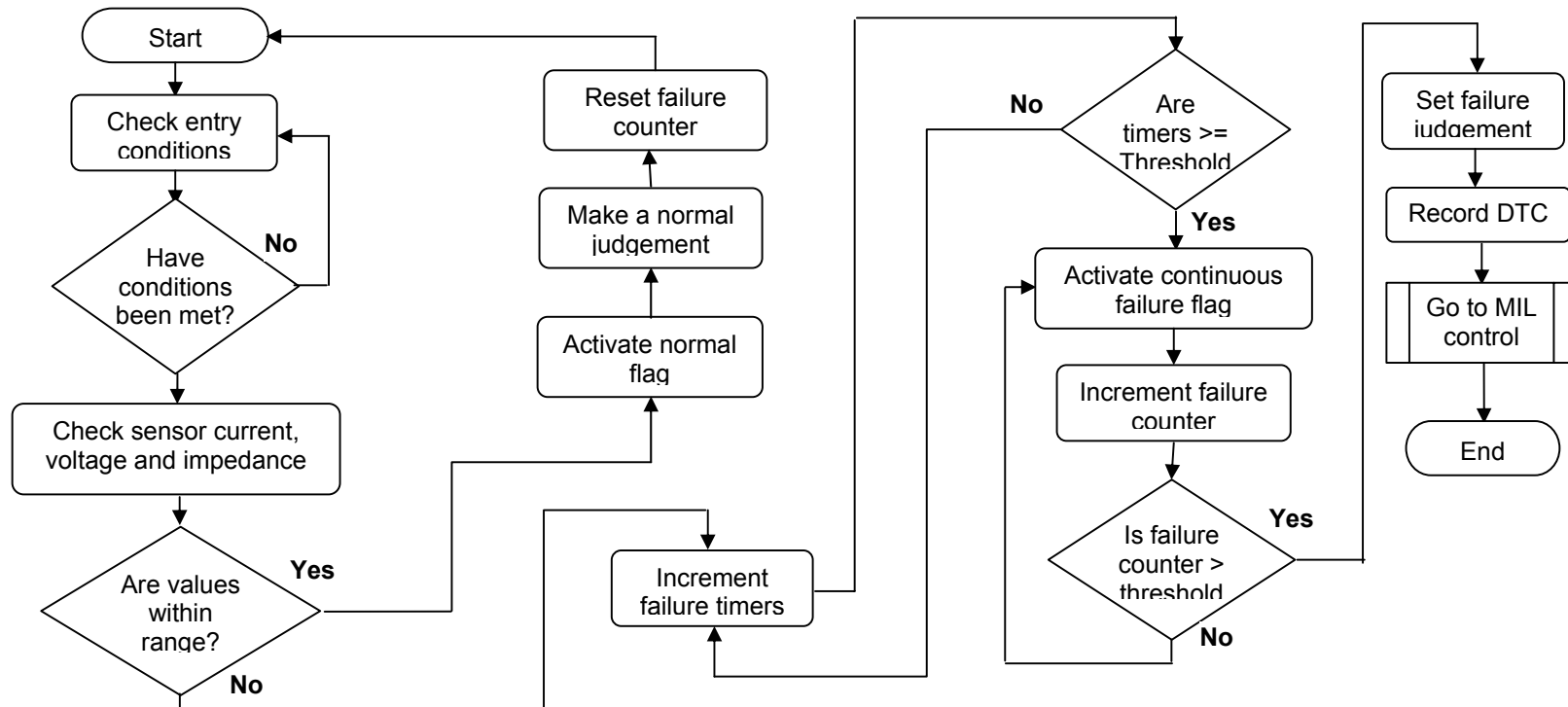

#### 4.5.2 Upstream Oxygen Sensor Slow Response

The upstream oxygen sensor slow response monitor operates once per drive cycle.

The monitor will be started once all the entry conditions are met. The fuelling is then cycled rich and lean by a set value. The time taken for the upstream oxygen sensors to register this fuelling shift is known. After this has elapsed a calculation of the air fuel ratio read by the sensor is made and divided by the expected increase or decrease.

This ratio is accumulated over a set number of fuelling shifts from rich to lean and lean to rich before a result is obtained. This ratio is lower for a faulty sensor than it is for a correctly functioning part. If the diagnostic produces a ratio that is over a calibrated threshold a "Normal" judgement is made, if the ratio is below the calibrated threshold then the diagnostic will be repeated. If the next measured ratio from the sensor is again below the calibrated threshold then that sensor is faulty and the relevant DTC will be stored and the MIL illuminated. Otherwise, the sensor is judged as fault free.

The flow chart below shows the operation of this monitor.

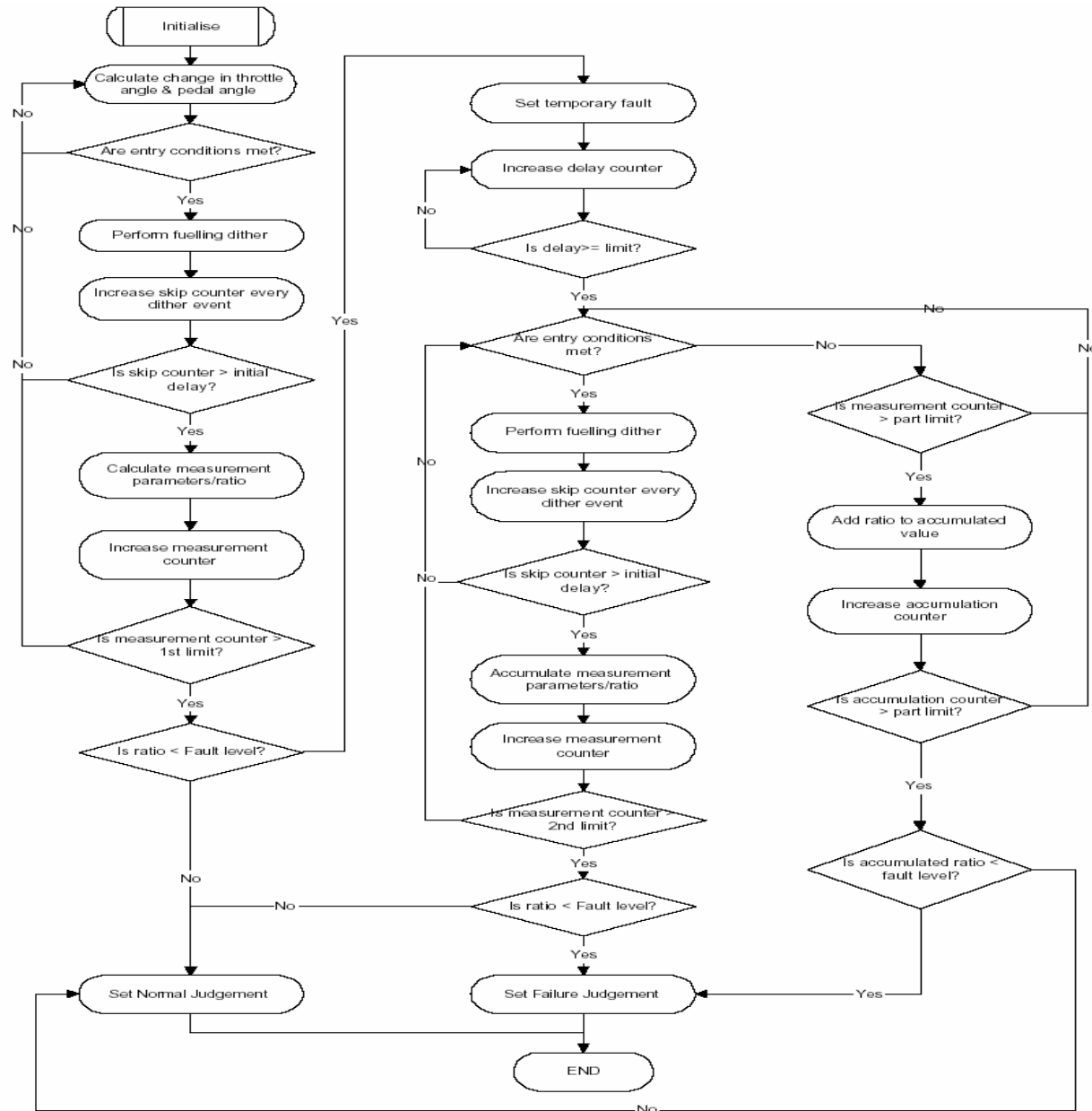

### 4.5.3 Upstream Oxygen Sensor Slow Activation

This monitor is used to check that the upstream oxygen sensors are operating correctly after the upstream oxygen sensor heaters have been turned on.

After the engine has started, the upstream oxygen sensor heaters are activated after a delay time. The monitor checks the change in impedance of the upstream oxygen sensors due to the heating. If the impedance level has not dropped by a defined level in a defined amount of time, then a failure will be detected.

The general flowchart of the monitor is shown below.

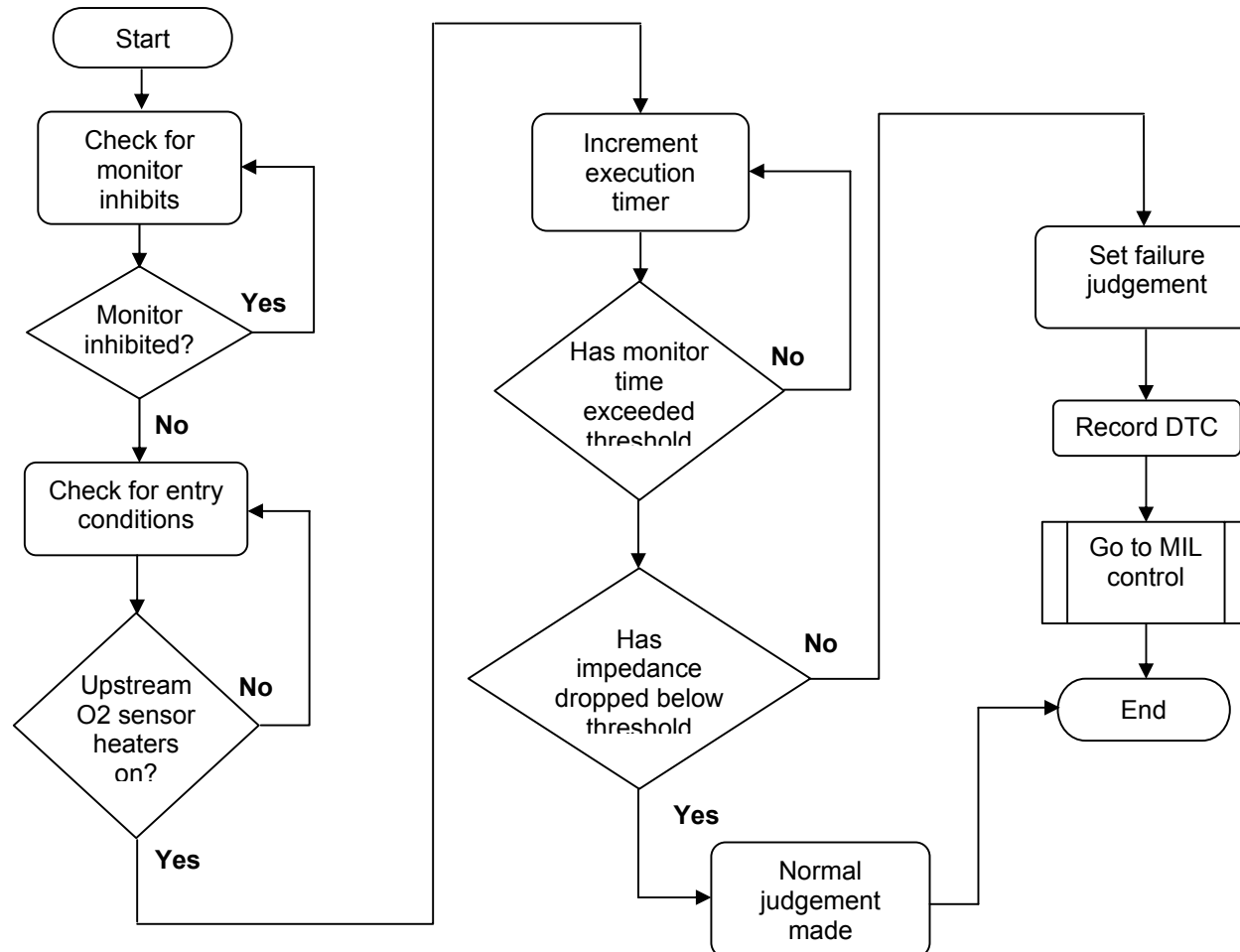



#### 4.5.4 Downstream Oxygen Sensor High or Low Monitor

This monitor checks the downstream oxygen sensor for a circuit fault. There are three parts to this monitor.

- High
- Low or Open circuit
- Short to battery

The short to battery diagnostic is designed to detect a fault that results in a downstream oxygen sensor voltage that is too high (e.g. a short circuit to the battery). If the voltage exceeds the short to battery threshold then a fault counter will be incremented. When the fault counter exceeds a pre-determined value then a fault code will be stored.

The high diagnostic is designed to detect a fault that results in a downstream oxygen sensor voltage that is permanently too high. It monitors the maximum voltage achieved by the downstream oxygen sensor after start. If after a fuel cut the voltage is still too high, but not high enough to detect a short to battery situation, then the downstream oxygen sensor high diagnostic flags a fault.

The low diagnostic is designed to detect a fault that results in a downstream oxygen sensor voltage that is permanently too low. It monitors the minimum voltage achieved by the downstream oxygen sensor after start. If, after the entry conditions are met, the voltage is still too low then a fault counter is incremented. If the fault counter exceeds a pre-determined value then a fault code will be stored.

A general flow diagram of the operation of this monitor is shown below.

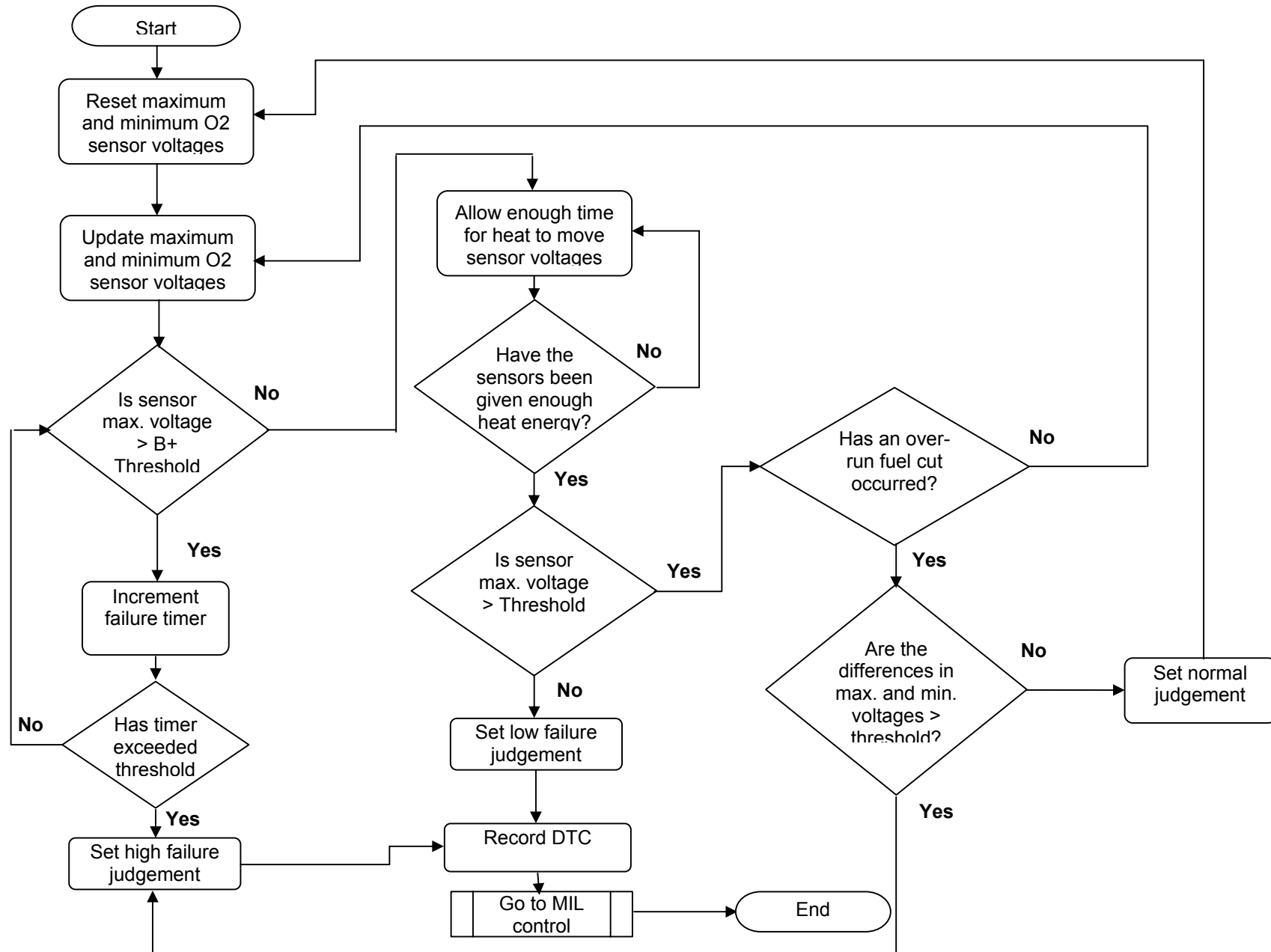

### 4.5.5 Downstream Oxygen Sensor Stuck Monitor

This monitor checks if the downstream oxygen sensor voltage has been at the same voltage during an overrun fuel-cut.

The stuck diagnostic is designed to detect if the downstream oxygen sensor voltage is permanently at a voltage that is within its normal operating range. If the entry conditions are met and that the fuel system and oxygen sensors are in working order, the downstream oxygen sensor maximum and minimum voltages are continuously updated. After an overrun fuel-cut has been performed, the difference in voltages before and after the fuel cut is compared. If the difference has not exceeded a threshold then a fault code will be stored.

A general flow chart of the diagnostic is shown below.

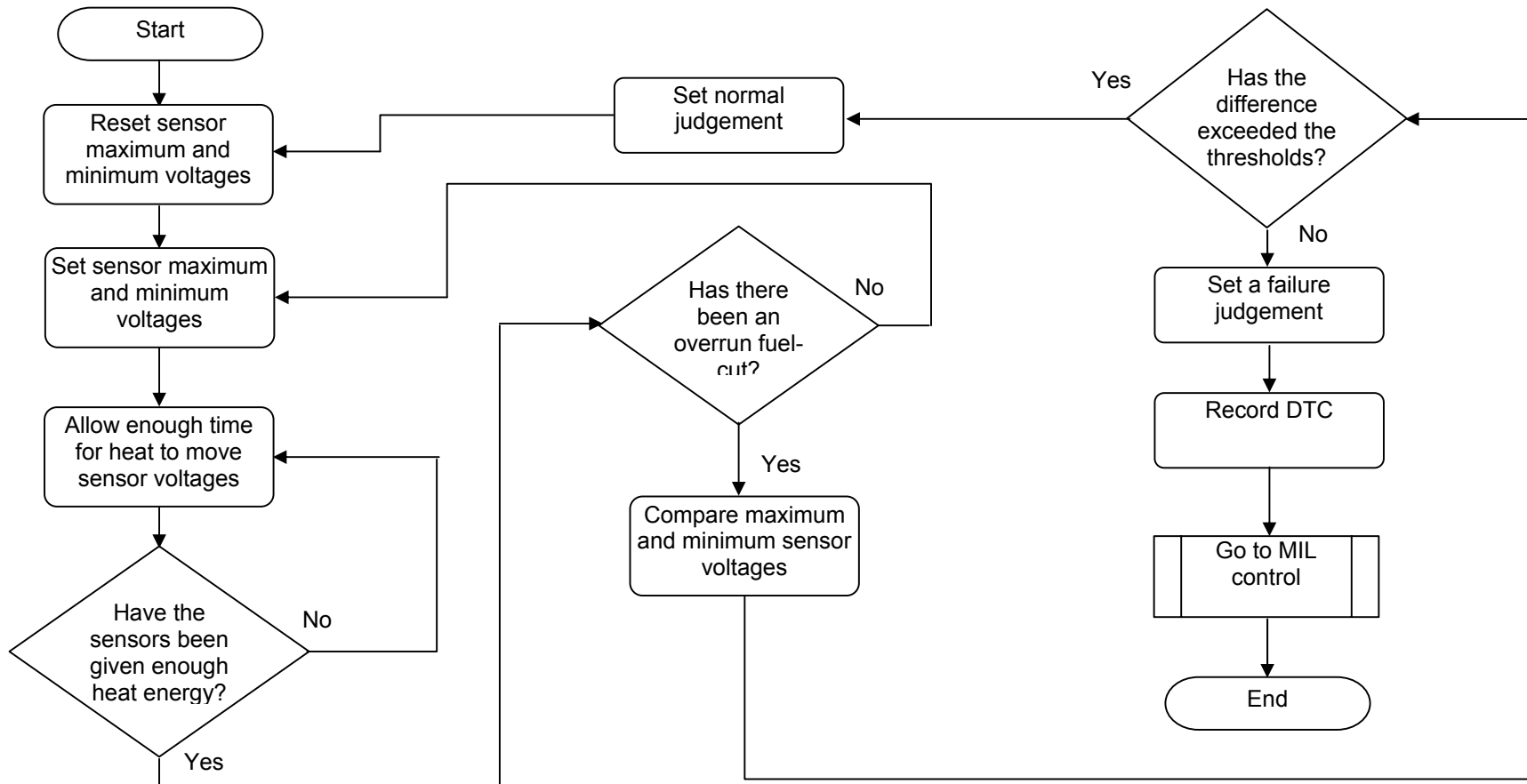

### 4.5.6 Downstream Oxygen Sensor Rationality Check

This monitor checks that the Sub-Feedback adaption values are within a specified range.

The diagnostic runs if the entry conditions have been met, all the oxygen sensors are working, the fuel system adaptations are within their limits and sub-feedback is operating. The monitor looks at the different sites of the Sub-feedback monitor and checks how many sites are over the fault threshold. If a pre-determined number of sites have exceeded this threshold, then a fault will be detected.

A general flowchart of the operation of this monitor is shown below.

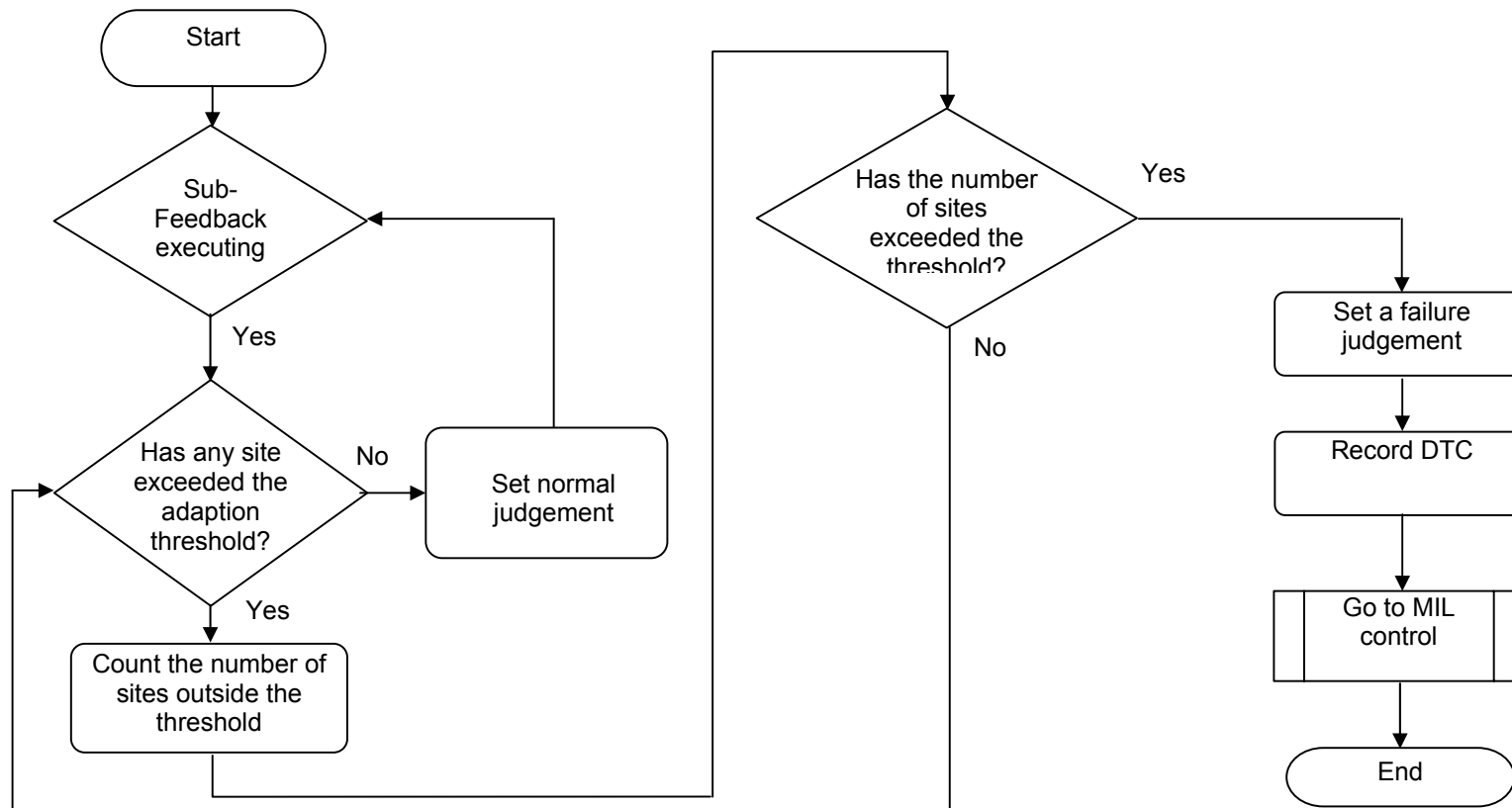

Downstream Oxygen Sensor Monitoring								
Component/System	Fault Codes	Monitoring Strategy Description	Malfunction Criteria	Threshold value	Secondary Parameter	Enable Conditions	Time Required	MIL
HO2S low input bank 1 HO2S low input bank 2 HO2S high input bank 1 HO2S high input bank 2	P0137 P0157 P0138 P0158	Sensor voltage stuck low  Sensor voltage stuck high	Sensor voltage maximum  Sensor voltage minimum   Or sensor voltage	< 0.1 V  > 0.2 V   > 1.2 V	Heater control Heater – total power Engine speed (IAT < -8°C) Mass airflow (IAT < -8°C) Engine speed (IAT > -8°C) Mass airflow (IAT > -8°C) Atmospheric pressure Target lambda Engine coolant temperature Intake air temperature After start counter Closed loop fuelling Over run fuel cutoff duration	Active >= 25% >= 1500 rpm >= 10 g/sec >= 500 rpm >= 4 g/sec >= 74.8 kPa 0 < lambda < 1.27 -15 < ECT < 120 °C -30 < IAT < 80 °C >= 30 sec Active >= 4.0 sec	5 sec  5 sec      5 sec	2 drive cycles 2 drive cycles 2 drive cycles 2 drive cycles
Disable DTCs:						P0133 P0153 P2096 P2097 P2098 P2099 P0420 P0430		
<b>Heater control circuit</b> Bank 1 low Bank 2 low Bank 1 high Bank 2 high	P0036 P0056 P0141 P0161	Heater resistance check at Off  Heater resistance check at On	Outside limits  Outside limits		Battery voltage	10.5 V < B+ < 16 V	0.432 s 0.432 s 0.432 s 0.432 s	2 drive cycles 2 drive cycles
Disable DTCs:						P0140 P0160 P2096 P2097 P2098 P2099 P0420 P0430		

Downstream Oxygen Sensor Monitoring								
Component/ System	Fault Codes	Monitoring Strategy Description	Malfunction Criteria	Threshold value	Secondary Parameter	Enable Conditions	Time Required	MIL
HO2S Bank 1 no activity	P0140	HO2S sensor voltage activity	Voltage maximum - minimum	< 0.5V	Heater control	Active >= 50000 %	5s	2 drive cycles
HO2S Bank 2 no activity	P0160				Accumulated HO2S heater power			Energy supplied
						Atmospheric pressure >= 74.8 kPa		
						Engine coolant temperature >= 70 °C		
						Intake air temperature >= -30°C		
						After start counter >= 30 sec		
						Closed loop fuelling		
						Over run fuel cut off duration		
						Disabled Fault Codes	P0133 P0153 P2096 P2097 P2098 P2099 P0420 P0430	

If the above table does not include details of the following enabling conditions: - IAT, ECT, vehicle speed range, and time after engine start-up then the state of these parameters has no influence upon the execution of the monitor.

Upstream Oxygen Sensor Monitoring									
Component/ System	Fault Codes	Monitoring Strategy Description	Malfunction Criteria	Threshold value	Secondary Parameter	Enable Conditions	Time Required	MIL	
HO2S bank 1 open	P0132	Control module hardware checks	Applied voltage too low	<= 2.0 V	HO2S Control	Active	5 sec	2 drive cycles	
HO2S bank 2 open	P0152		Applied voltage too high	>= 4.0 V	Heater Duty		<= 21.8 sec for 3 minutes	5 sec	2 drive cycles
HO2S bank 1 shorted	P0131		Applied current too low	<= -5.0 mA				5 sec	2 drive cycles
HO2S bank 2 shorted	P0151		Applied current too high	>= 5.0 mA				5 sec	2 drive cycles
			Sensor impedance	>= 60 ohm					

Upstream Oxygen Sensor Monitoring								
Component/ System	Fault Codes	Monitoring Strategy Description	Malfunction Criteria	Threshold value	Secondary Parameter	Enable Conditions	Time Required	MIL
					Disabled DTCs	P0134 P0154 P2096 P2097 P2098 P2099 P0420 P0430		
HO2S bank 1 slow response HO2S bank 2 slow response	P0133  P0153	Accumulated response time to applied fuelling dither during steady state driving	Response rate time ratio	< 0	Engine speed Mass airflow Engine coolant temperature Atmospheric pressure Element impedance Vapour concentration Time after start Closed loop air /fuel control and Sub feedback control Gn load Disabled DTCs	400 < RPM < 900 rpm 3 < MAF < 10 g/sec > = 75 °C  >= 68 kPa 0 < R < 60 ohm <= 255 >= 60 s Active  0 to 1 g/rev P2096 P2097 P2098 P2099 P0420 P0430	30 sec	2 drive cycles 2 drive cycles
Heater control circuit bank 1 low Heater control circuit bank 1 high Heater control circuit bank 2 low Heater control circuit bank 2 high	P0031  P0032  P0051  P0052	HO2S Control Module monitors  heater for current to be within limits			HO2S control Heater Duty	Executing 13 to 115 msec	5.1 sec	2 drive cycles 2 drive cycles 2 drive cycles 2 drive cycles

If the above table does not include details of the following enabling conditions: - IAT, ECT, vehicle speed range, and time after engine start-up then the state of these parameters has no influence upon the execution of the monitor.

#### 4.5.7 Drive Cycle Information

##### Upstream (Universal) oxygen sensors:

1. Engine OFF; cooling fans inoperative > 20 seconds.
2. Start engine, coolant < 60°C (140 °F), and bring to normal operating temperature > 82 °C (180 °F).
3. Drive vehicle > 1500 rpm for 5 minutes
4. Bring vehicle to stop and idle for > 60 seconds

##### Downstream oxygen sensors:

1. Start engine and bring to normal operating temperature > 82 °C (180 °F).
2. Drive the vehicle steadily between 48 – 97 km/h (30 – 60 mph) for 10 minutes.
3. Drive the vehicle above 3000 rpm in 3rd gear at a steady speed. Lift foot completely off accelerator and coast for 30 seconds.

##### Oxygen sensor heaters:

1. Start engine and bring to normal operating temperature > 82 °C (180 °F).
2. Idle engine for 3 minutes.



## 4.6 Thermostat Monitoring

### 4.6.1 System Schematic

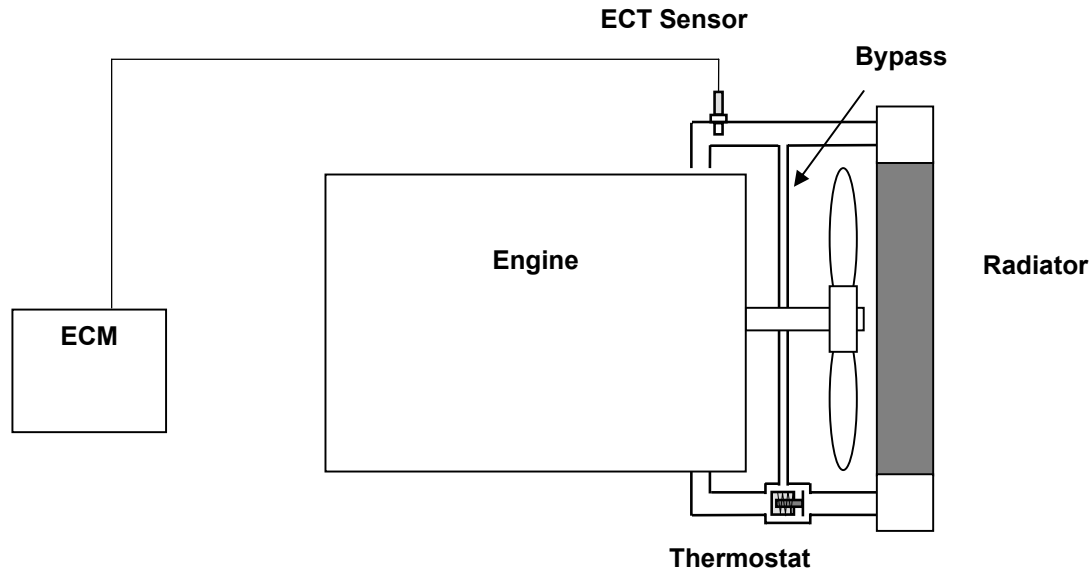

### 4.6.2 Description

This monitor operates once per drive cycle. It calculates the difference between the measured coolant temperature and an estimated temperature that is derived from a model. When the estimated temperature reaches a calibrated threshold then the error between the two temperatures is accumulated. The model used to calculate the estimated coolant temperature has look-up tables that use a number of engine and vehicle parameters (engine speed, engine airflow, vehicle speed and the difference between intake air and coolant temperature) to derive compensation values. These are added or subtracted from the estimated coolant temperature as appropriate.

An after start counter is also included. The estimated coolant temperature is taken as the measured coolant temperature for a calibratable time following engine start (this time is dependant on the starting coolant temperature) to overcome second order effects which introduce inaccuracy into the estimate of coolant temperature. A normal judgement is made if the measured coolant temperature reaches 80 °C and the accumulated error is not above the failure threshold. A failure judgement is made if the accumulated error equals or exceeds a calibratable fault threshold before the measured coolant temperature reaches 80 °C.

Thermostat Monitoring								
Component/ System	Fault Codes	Monitoring Strategy Description	Malfunction Criteria	Threshold value	Secondary Parameter	Enable Conditions	Time Required	MIL
Thermostat range or performance	P0128	Comparison of actual warm up profile with estimated. Judgement performed when actual ECT reaches 80°C or accumulated difference between actual and estimated coolant temperature reaches threshold	Accumulated difference between estimated ECT and actual ECT is too large	>Map 6	Intake air temperature ECT @ start Mass Airflow Engine Speed	- 8 < IAT < 50 °C - 8 < ECT < 60 °C >= 1.0 g/sec <= 8000 rpm	Dependent upon drive cycle	2 drive cycles
P0128 Disabled Fault Codes						None		

If the above table does not include details of the following enabling conditions: - IAT, ECT, vehicle speed range, and time after engine start-up then the state of these parameters has no influence upon the execution of the monitor.

### Map 6

Accumulate difference between estimated and actual ECT threshold									
x-axis units	deg.C								
y-axis units	deg.C								
Data units	deg.C								
	-40	0	20	40	60	80	100	110	120
-40	2000	2000	2000	2000	2000	2000	2000	2000	2000
0	2000	2000	2000	2000	2000	2000	2000	2000	2000
20	2000	2000	2000	2000	2000	2000	2000	2000	2000
40	2000	2000	2000	2000	2000	2000	2000	2000	2000
60	2000	2000	2000	2000	2000	2000	2000	2000	2000
80	2000	2000	2000	2000	2000	2000	2000	2000	2000
100	2000	2000	2000	2000	2000	2000	2000	2000	2000
110	2000	2000	2000	2000	2000	2000	2000	2000	2000
120	2000	2000	2000	2000	2000	2000	2000	2000	2000

## 4.7 Idle Speed Control

### 4.7.1 Description

If all the entry conditions are satisfied, then the monitor will start execution.

If the actual engine speed more than 100 rpm lower than the target engine speed then a counter is started and once this exceeds the failure time limit a failure judgement is made for idle speed lower than expected.

If the actual engine speed is greater than 200 rpm higher than the target engine speed then a counter is started and once this exceeds the failure time limit a failure judgement is made for idle speed higher than expected.

Idle Speed Control Monitoring								
Component/ System	Fault Codes	Monitoring Strategy Description	Malfunction Criteria	Threshold value	Secondary Parameter	Enable Conditions	Time Required	MIL
	P0506	Idle speed lower than expected	Idle speed versus target	100 rpm too low	Engine coolant temperature	70 < ECT < 119 °C	4.992 sec	2 Drive Cycles
	P0507	Idle speed higher than expected	Idle speed versus target	200 rpm too high	Atmospheric pressure Time after start Intake air temperature Idle speed control a active for Vehicle speed Time since air-conditioning relay, P/N –Drive or brake switch has changed state	>= 68 kPa >= 25.024 sec >= -30 °C >= 5 sec <= 0 mph 5 sec	4.992 sec	2 Drive Cycles
Disabled Fault Codes						None		

If the above table does not include details of the following enabling conditions: - IAT, ECT, vehicle speed range, and time after engine start-up then the state of these parameters has no influence upon the execution of the monitor.

## 4.8 Crankshaft Position and Engine Speed Sensor

### 4.8.1 Description

The crankshaft sensor is checked for loss of signal during cranking and engine running conditions. When the appropriate entry conditions have been met a loss of sensor pulses for greater than the predefined time will register a fault. If the fault is registered on 2 drive cycles then the MIL will illuminate.

Additionally if the number of crankshaft sensor pulses is incorrect by more than one pulse in any one engine revolution then a fault event is recorded. If the number of fault events exceeds the limit without the engine synchronising then a crankshaft range performance fault is registered. If the fault is registered on 2 drive cycles then the MIL will illuminate.

Crankshaft Position and Engine Speed Sensor								
Component/ System	Fault Codes	Monitoring Strategy Description	Malfunction Criteria	Threshold value	Secondary Parameter	Enable Conditions	Time Required	MIL
Malfunction	P0335	1) Crankshaft sensor signal when engine cranking	Camshaft signal pulses seen before crank pulse	$\geq 42$	Cranking Battery voltage (B+) Camshaft pulses seen	Operation $\geq 8\text{ V}$ $\geq 2$	2 sec	2 drive cycles
Malfunction	P0335	2) Crankshaft sensor during engine running	Number of 30 deg crank angle timings since crank pulse	$\geq 10$	Engine speed	$\geq 500\text{ rpm}$	2 sec	2 drive cycles
Range / Performance	P0336	Number of crankshaft sensor pulses judged between missing tooth	Not correct	$< 35$	Engine speed Reverse gear	$\geq 650\text{ rpm}$ Not selected		2 drive cycles
Disabled DTCs				P0069 P0096 P0101 P0106 P010B P0111 P0116 P0125 P0128 P0133 P0140 P0153 P0160 P0181 P0196 P0401 P0420 P0430 P0441 P1147				

If the above table does not include details of the following enabling conditions: - IAT, ECT, vehicle speed range, and time after engine start-up then the state of these parameters has no influence upon the execution of the monitor.

## 4.9 Camshaft Position Sensors

### 4.9.1 Description

Camshaft position sensors are fitted to both cylinder banks.

The camshaft sensors are checked for loss of signal during cranking and engine running conditions. When the appropriate entry conditions have been met a loss of camshaft sensor pulses for greater than the predefined time will register a fault. If the fault is registered on 2 drive cycles then the MIL will illuminate.

Additionally if a camshaft sensor pulse is not detected between crankshaft sensor missing teeth on more than 4 occasions then a fault event is recorded. If the fault is registered on 2 drive cycles then the MIL will illuminate.

Camshaft Position Sensor								
Component/ System	Fault Codes	Monitoring Strategy Description	Malfunction Criteria	Threshold value	Secondary Parameter	Enable Conditions	Time Required	MIL
Bank 1 Malfunction	P0340	1) Camshaft sensor pulse during starting	Number of pulses seen	< 2	Cranking Battery voltage Battery voltage low point (starter inrush)	Operation >= 8.0V  < 10.5 V	1.104 sec	2 drive cycles
Bank 2 Malfunction	P0345							2 drive cycles
Bank 1 Malfunction	P0340	2) Camshaft sensor during engine running	No Camshaft sensor pulses seen	No pulse	Battery voltage Engine speed Cranking	>= 8.0 V >= 600 rpm Not active	5	2 drive cycles
Bank 2 Malfunction	P0345							2 drive cycles
Bank 1 Range / Performance	P0341	Camshaft sensor pulses during engine running	Number of camshaft sensor pulses seen	<> 4	Engine speed Crankshaft sensor	>= 600 rpm Not failed		2 drive cycles
Bank 2 Range / Performance	P0346							2 drive cycles
Disabled DTCs						P0101 P0106 P010B P0133 P0140 P0153 P0160 P0401 P0420 P0430		

If the above table does not include details of the following enabling conditions: - IAT, ECT, vehicle speed range, and time after engine start-up then the state of these parameters has no influence upon the execution of the monitor.

## **4.10 Engine Coolant Temperature (ECT) Sensor**

### **4.10.1 Sensor Stuck**

This monitor checks that the ECT sensor is not stuck at a particular value. If the engine has been off for greater than a calibrated time and the engine speed is over a calibrated limit, then the ECT must change by a calibrated amount before the engine oil temperature (EOT) has changed by a calibrated value or a failure will be detected. If the ECT does change by an amount equal to or greater than this threshold then a normal judgement is made.

### **4.10.2 Range or Performance Failure**

The monitor checks that the ECT sensor is reading a correct value when compared to other temperature sensors on the vehicle at ignition on.

If the engine has been off for greater than a calibrated time, then the ECT sensor reading is compared to the average reading of the sum of the intake air temperature (IAT) and ambient air temperature (AAT) sensors. The ECT sensor must be within a calibrated threshold of this value for a normal judgement to be made, otherwise a fault will be detected.

### **4.10.3 Time to Closed Loop Fuelling**

The ECT is monitored to ensure it reaches the closed loop fuelling enable temperature. If the IAT is above the required level, then the following strategy will be enabled.

The timer is incremented when the engine speed and airflow are above pre-determined thresholds. A normal judgement is made if the ECT reaches the value for closed loop fuelling before the timer reaches the fault threshold.

A failure judgement is made if the load conditions met timer reaches the fault threshold before the ECT reaches the value required for closed loop fuelling.

The fault threshold is obtained from a look up table that is mapped against the ECT at engine start.

#### 4.10.4 Range/Performance Flow chart

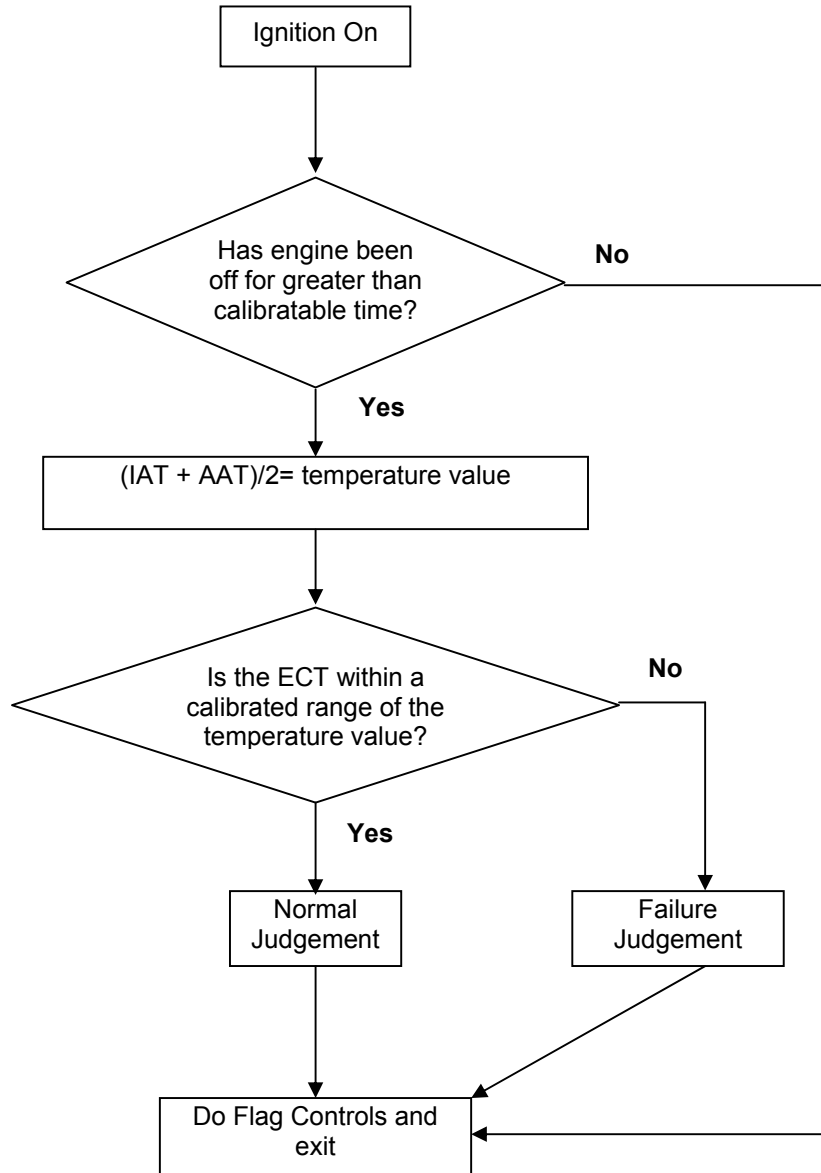

Engine Coolant Temperature Sensor								
Component/System	Fault Codes	Monitoring Strategy Description	Malfunction Criteria	Threshold Value	Secondary Parameter	Enable Conditions	Time Required	MIL
ECT sensor high input	P0118	Out of range check	ECT sensor voltage	$\leq 4.91 \text{ V}$		Ignition On	16	2 drive cycles
ECT sensor low input	P0117	Out of range check	ECT sensor voltage	$\geq 0.01 \text{ V}$		Ignition On	16	
ECT sensor Range/performance	P0116	Coolant temperature stuck	ECT sensor voltage	$> 0.015 \text{ V}$	Engine speed Change in engine oil temperature	$\geq 500 \text{ rpm}$ $\geq 30 \text{ }^\circ\text{C}$	500 msec	2 drive cycles
ECT sensor Range/performance	P0116	Range / performance	ECT within tolerances of average of ambient temperature and intake air temperature	$> 30 \text{ }^\circ\text{C}$	Engine off Difference between IAT average and ambient temperature average	$> 480 \text{ minutes}$ $< 5 \text{ }^\circ\text{C}$		
ECT sensor Range/performance	P0125	Time to closed loop air/fuel control enable temperature	ECT not at closed loop fueling enable temperature	$< -15 \text{ }^\circ\text{C}$	Engine speed Mass Airflow Intake air temperature	$\geq 400 \text{ rpm}$ $\geq 3 \text{ g/sec}$ $\geq -40 \text{ }^\circ\text{C}$	Table 11	2 drive cycles
Disabled DTCs				P0069 P0096 P0101 P0106 P010B P0111 P0116 P0125 P0128 P0133 P0140 P0153 P0160 P0196 P0401 P0420 P0430 P1147				

If the above table does not include details of the following enabling conditions: - IAT, ECT, vehicle speed range, and time after engine start-up then the state of these parameters has no influence upon the execution of the monitor.

**Table 11**

ECT Sensor Time to closed loop enable temperature												
Minimum closed loop enable Temperature ( $^\circ\text{C}$ )	-40	-30	-20	-10	0	10	20	30	40	50	60	80
Time (s)	450	400	350	300	210	120	120	120	120	120	120	120



## **4.11 Manifold Absolute Pressure Sensor**

### **4.11.1 High or Low Input Failure and Ground Monitor**

This monitor runs continuously. The voltage from the sensor is compared with failure thresholds that are defined in the software.

If the voltage is below the low threshold, then a timer will be incremented. If this timer exceeds a threshold, then a failure flag is set and a DTC is stored.

If the voltage is over the high threshold, then a timer will be incremented. If this timer exceeds a threshold, then a failure flag is set and a DTC is stored.

### **4.11.2 Range / Performance Failure**

The monitor runs continuously so long as the entry conditions are met. The Manifold Absolute Pressure (MAP) Sensor monitor compares the measured manifold absolute pressure with an estimated pressure, which is calculated by a model. The model that calculates the estimated pressure uses a look-up table which have engine speed and throttle angle as inputs. These are used to derive base and compensation values for intake air temperature, atmospheric pressure, EGR rate and VVT, from which the estimated pressure is calculated.

Judgements of whether the MAP sensor is behaving correctly are made after the entry conditions have been fulfilled and the differences between the measured and estimated values are below calibrated thresholds. The MAP sensor is faulty if when the entry conditions are met, the difference between the actual and estimated values is greater than a calibrated threshold. The monitor has the ability to make a normal judgement followed by a failed judgement or vice versa as the monitor runs continuously whilst the entry conditions are met.

### 4.11.3 Flow Chart

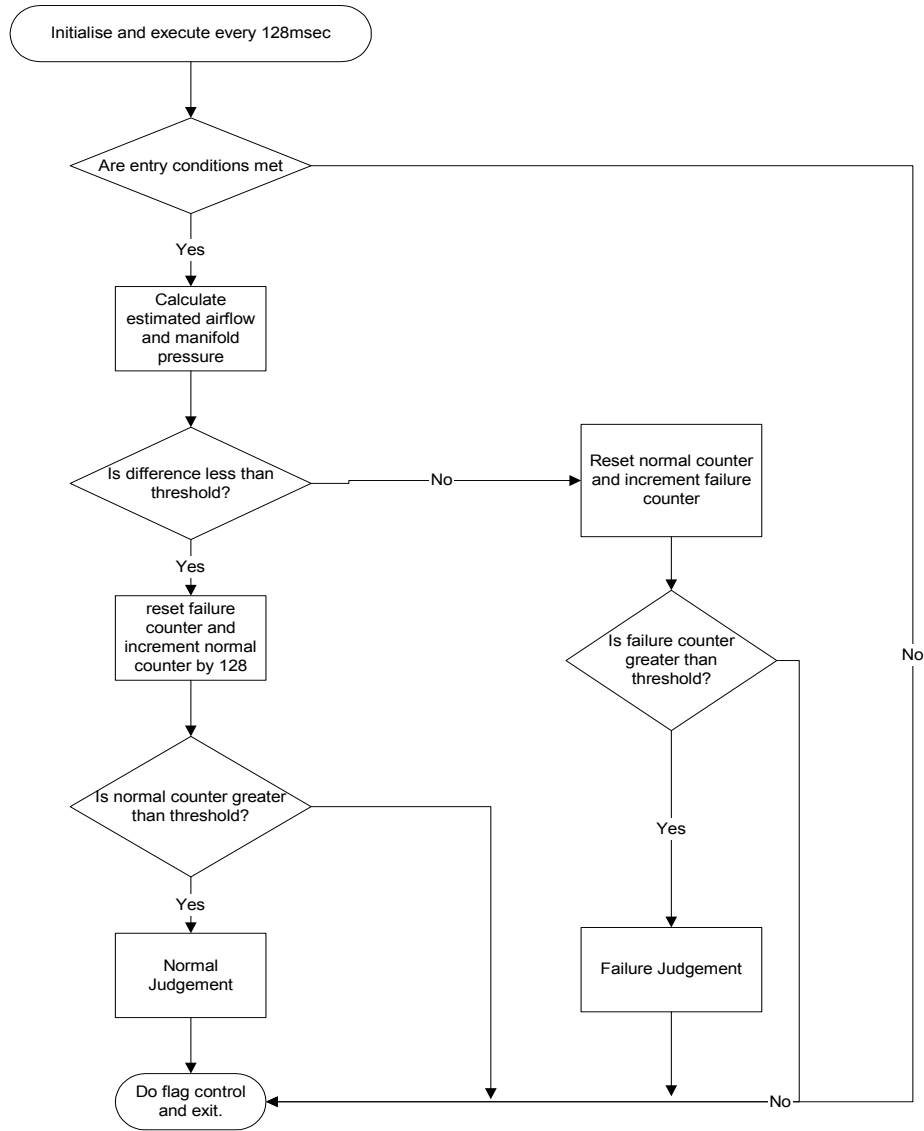

Manifold Absolute Pressure Sensor								
Component/ System	Fault Codes	Monitoring Strategy Description	Malfunction Criteria	Threshold value	Secondary Parameter	Enable Conditions	Time Required	MIL
MAP sensor high input MAP sensor low input MAP sensor Range / Performance	P0108	Out of range check	MAP sensor voltage	$\geq 4.891$ V			16	2 drive cycles
	P0107	Out of range check	MAP sensor voltage	$\leq 0.17$ V			16	2 drive cycles
	P0106	Rationality – measured versus estimate based on TP & RPM with compensation for altitude, EGR and temperature.	Measured MAP $\leftrightarrow$ limit from estimate	25 kPa	Engine Speed Engine coolant Temperature Intake air temperature Atmospheric pressure Throttle position Throttle position change Not idling Disabled Fault Codes	1000 to 45000 rpm -10 < ECT < 120 °C -30 < IAT < 100 °C  $\geq 68$ kPa 5% < TP < 60% $\leq 1$ % per 32 msec  P0069 P0096 P0106 P0111 P0116 P0125 P0128 P0133 P0140 P0153 P0160 P0420 P0430 P0441 P1147	5000 kPa	2 drive cycles

If the above table does not include details of the following enabling conditions: - IAT, ECT, vehicle speed range, and time after engine start-up then the state of these parameters has no influence upon the execution of the monitor.

## **4.12 Mass Airflow Sensor**

### **4.12.1 High or Low Input Failure and Ground Monitor**

This monitor runs continuously. The voltage from the sensor is compared with failure thresholds that are defined in the software.

If the voltage is below the low threshold, then a timer will be incremented. If this timer exceeds a threshold, then a failure flag is set and a DTC is stored.

If the voltage is over the high threshold, then a timer will be incremented. If this timer exceeds a threshold, then a failure flag is set and a DTC is stored.

For MAF sensor short to ground or open circuit monitoring, then the voltage on the ground pin of the MAF sensor is monitored in the same way as described above.

### **4.12.2 Range / Performance Failure**

The monitor runs continuously so long as the entry conditions are met. The MAF sensor monitor compares the measured airflow with an estimated airflow, which is calculated by a model. The model that calculates the estimated airflow uses a look-up table which has engine speed and throttle angle as inputs. These are used to derive base and compensation values for intake air temperature, atmospheric pressure, EGR rate and VVT, from which the estimated airflow is calculated.

Judgements of whether the MAF sensor is behaving correctly are made after the entry conditions have been fulfilled and the differences between the measured and estimated values are below calibrated thresholds. The MAF sensor is faulty if when the entry conditions are met, the difference between the actual and estimated values is greater than a calibrated threshold. The monitor has the ability to make a normal judgement followed by a failed judgement or vice versa as the monitor runs continuously whilst the entry conditions are met.

### 4.12.3 Flow Chart

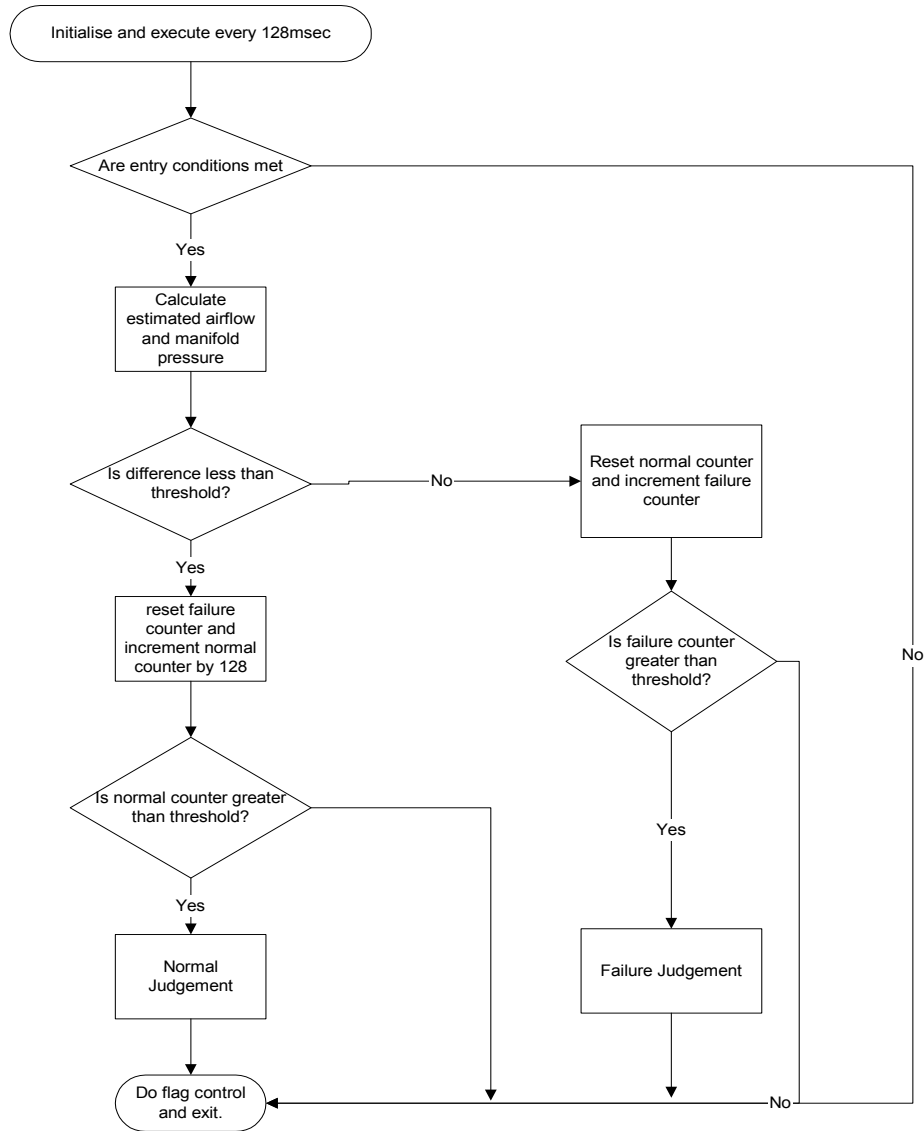

Mass Airflow Sensor								
Component/System	Fault Codes	Monitoring Strategy Description	Malfunction Criteria	Threshold value	Secondary Parameter	Enable Conditions	Time Required	MIL
Mass Airflow Sensor MAF sensor high input MAF sensor low input MAF sensor Range / Performance	P0103	Out of range check	MAF sensor voltage	$\geq 4.91$ V			16	2 drive cycles
	P0102	Out of range check	MAF sensor voltage	$\leq 0.06$ V			16	2 drive cycles
	P0101	Rationality – measured versus estimate based on TP & RPM with compensation for altitude, EGR and temperature.	Measured MAF outside limit	$\leq 0.75$ $\geq 1.25$	Engine Speed Engine coolant Temperature Intake air temperature Atmospheric pressure Throttle position Throttle position change Not idling	1000 < RPM < 5000 rpm -10 < ECT < 120 °C  -30 < IAT < 100 °C  $\geq 68$ kPa  5 % < TP < 80 % $\leq 2$ % per 128 msec	14.98s	2 drive cycles
						P0101 Disabled DTCs	P0096 P0101 P0111 P0116 P0125 P0128 P0133 P0140 P0153 P0160 P0420 P0430 P1147	

If the above table does not include details of the following enabling conditions: - IAT, ECT, vehicle speed range, and time after engine start-up then the state of these parameters has no influence upon the execution of the monitor.

## **4.13 Barometric Pressure Sensor**

The Barometric pressure sensor (also referred to as the High Altitude Compensation sensor) is located within the ECM.

### **4.13.1 High /Low Input Failure**

These are continuous monitors. The voltage from the sensor is compared to a failure threshold defined in the software. If the voltage is below the low threshold, then a timer starts to increment. Once this timer exceeds another threshold, then a failure flag is set and a DTC is stored. If the voltage is over the high threshold defined in the software, then a timer starts to increment. Once this timer exceeds a threshold, then a failure flag is set and a DTC is stored.

### **4.13.2 Range / Performance Failure**

The signal from the sensor is compared to the signal from the Manifold Absolute Pressure sensor (MAP) at ignition on only. During this time the pressure within the inlet manifold should be at atmospheric, and therefore should match the value from the barometric pressure sensor.

The following conditions must be met first before the monitor can execute;

- Engine speed = 0
- Vehicle speed = 0
- Monitor is not inhibited
- Ignition is on
- Engine is not cranking
- Battery voltage exceeds minimum threshold
- Coolant temp above minimum threshold
- Atmospheric pressure within limits
- Inlet manifold pressure value has settled

If the absolute value of the difference between the signal from the barometric pressure sensor and the MAP sensor differ by more than a defined amount, then a timer is executed. If the timer exceeds a calibrated amount, a temperature failure is judged. Providing there is no failure of the MAP sensor, a DTC is then stored.

Barometric Pressure Sensor								
Component/ System	Fault Codes	Monitoring Strategy Description	Malfunction Criteria	Threshold value	Secondary Parameter	Enable Conditions	Time Required	MIL
Barometric sensor high input	P2229	Out of range check	Sensor voltage	$\geq 4.791$ V			16	2 drive cycles
Barometric sensor low input	P2228	Out of range check	Sensor voltage	$\leq 0.05$ V			16	2 drive cycles
Barometric sensor Range / Performance	P0069	Comparison with MAP sensor signal and Barometric pressure signal	Difference (+/-)	$> 10$ kPa	Engine Speed Engine coolant Temperature Intake air temperature Vehicle speed Battery voltage Time after ignition On Delta MAP	Ignition On = 0 rpm $\geq -30$ °C  $\geq -30$ °C  = 0 mph $\geq 10.5$ V 64 < time < 1000 msec $\leq 0.023$ kPa per 32 msec	0.192 sec	2 drive cycles
P0069 Disabled DTCs						P0069 P0101 P0106 P010B P0133 P0140 P0153 P0160 P0420 P0430 P0441		

If the above table does not include details of the following enabling conditions: - IAT, ECT, vehicle speed range, and time after engine start-up then the state of these parameters has no influence upon the execution of the monitor.



## 4.14 Fuel Rail Pressure Sensor

### 4.14.1 High / Low Input Failure

These are continuous monitors. The voltage from the sensor is compared to a failure threshold defined in the software. If the voltage is below the low threshold, then a timer starts to increment. Once this timer exceeds another threshold, then a failure flag is set and a DTC is stored. If the voltage is over the high threshold defined in the software, then a timer starts to increment. Once this timer exceeds a threshold, then a failure flag is set and a DTC is stored.

### 4.14.2 Range Performance

Stuck at monitoring executes when closed loop fuel pump control is executing. It checks that the fuel rail pressure signal has varied by at least 3 kPa over a range of demanded fuel pump duties. The maximum and minimum fuel rail pressures are updated each time. The change in demand duty is integrated and the variation between the max and min values is checked. If it is less than 3 kPa, failure judgement is made; otherwise, a normal judgement is made.

### 4.14.3 Fuel System Pressure

The actual fuel system pressure is compared to the target pressure. If the difference between actual and target pressures exceed the defined thresholds then a failure is registered. If a failure is registered on two consecutive drive cycles then the MIL will be illuminated.

Fuel Rail Pressure Sensor								
Component/ System	Fault Codes	Monitoring Strategy Description	Malfunction Criteria	Threshold value	Secondary Parameter	Enable Conditions	Time Required	MIL
Sensor high input	P0193	Out of range check	Fuel rail pressure voltage	$\geq 4.95$ V			16	2 Drive Cycles
Sensor low input	P0192	Out of range check	Fuel rail pressure voltage	$\leq 0.10$ V			16	2 Drive Cycles
Sensor range/ performance	P0191	Rationality- deviation  measured during pump duty deviation	Difference	$\leq 3$ kPa	Fuel level Battery voltage Ambient temperature Accumulated pump duty deviation Disabled fault codes	$\geq 5\%$ $\geq 10.5$ V $\geq -20$ °C $\geq 1.00\%$		2 drive cycles
Fuel system	P0087	Rationality –	Accumulated delta	$< -35$ kPa	Battery voltage	P0133 P0153 P0191 $\geq 10.5$ V	P0420 P0430 25s	2 drive

Fuel Rail Pressure Sensor								
Component/ System	Fault Codes	Monitoring Strategy Description	Malfunction Criteria	Threshold value	Secondary Parameter	Enable Conditions	Time Required	MIL
pressure too high Fuel system pressure too low	P0088	measured versus target Rationality – measured versus target	Accumulated delta	> 35 kPA	Ignition On time Fuel level	>= 1984 sec >= 5 %		cycles  2 drive cycles
Disabled Fault Codes						P0133 P0153		

If the above table does not include details of the following enabling conditions: - IAT, ECT, vehicle speed range, and time after engine start-up then the state of these parameters has no influence upon the execution of the monitor.

## **4.15 Intake Air Temperature Sensor**

### **4.15.1 Sensor Stuck**

This monitor checks that the IAT sensor is not stuck at a particular value. If the airflow into the engine is over a threshold for greater than a calibratable time, then the IAT sensor reading is stored. The next time the airflow into the engine drops below a second threshold and the engine is idling, then a second timer is incremented. Once this timer reaches a pre-determined value, then the IAT sensor reading is stored again. The high flow temperature is subtracted from the low flow temperature and if the difference is greater than a threshold, then a normal judgement will be made. If the result is less than the threshold then a failure will be detected.

### **4.15.2 Range or Performance Failure**

The monitor checks that the IAT sensor is reading a correct value when compared to other sensors on the vehicle.

If the engine has been off for greater than a calibrated time period, then the IAT sensor reading is compared to the average of the sum of the ECT sensor and AAT sensor. The IAT sensor must be within a calibrated threshold of this reading for a normal judgement to be made. If it is outside this threshold then a failure is flagged.

### 4.15.3 Range/Performance Flow chart

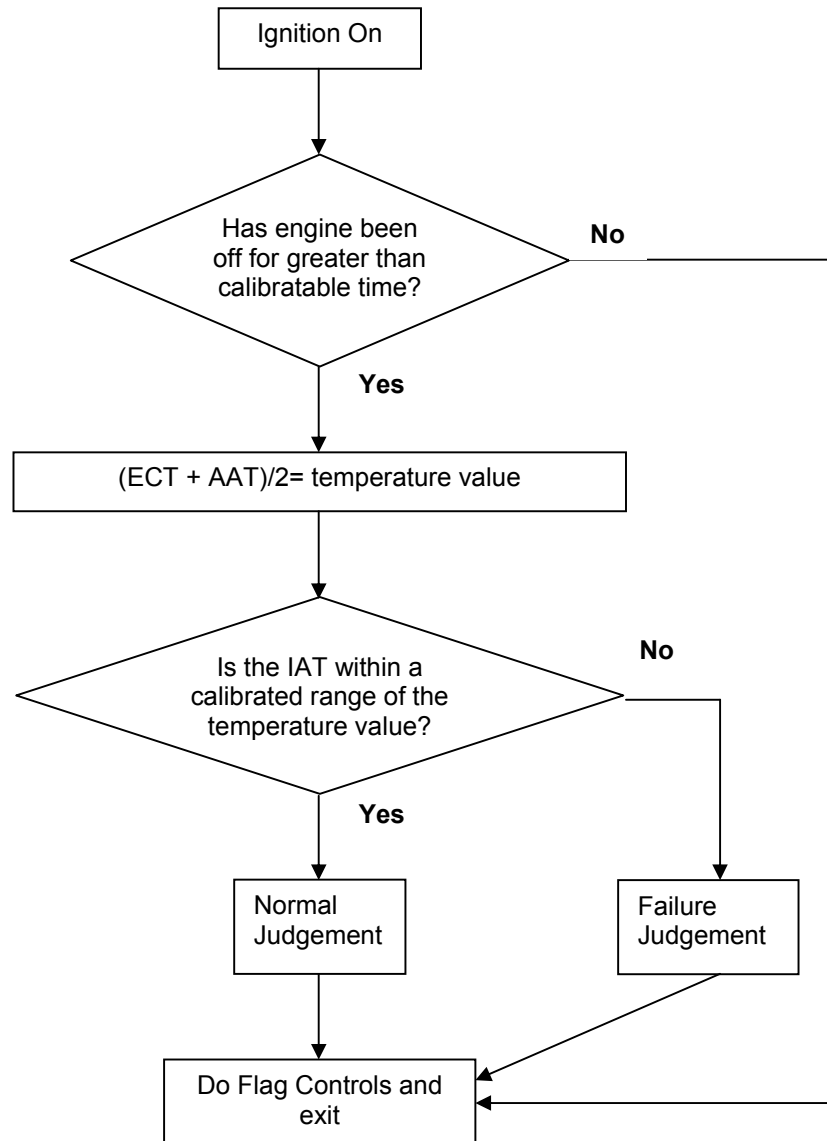

Intake Air Temperature Sensor								
Component/ System	Fault Codes	Monitoring Strategy Description	Malfunction Criteria	Threshold value	Secondary Parameter	Enable Conditions	Time Required	MIL
IAT sensor high input	P0113	Out of range check	IAT sensor voltage	$\leq 4.90$ V			16	2 drive cycles
IAT sensor low input	P0112	Out of range check	IAT sensor voltage	$\geq 0.11$ V			16	2 drive cycles
IAT sensor range / performance	P0111	Range performance	IAT difference with respect to average of EOT and ECT	$> 30$ °C	Engine off Difference between ECT and ambient air temperature Start ECT minus ECT	$> 480$ minutes $> 5$ °C  $\geq 4$ °C		
IAT sensor range / performance	P0111	IAT sensor voltage movement after soak up at idle and cool down during driving	IAT sensor voltage movement	$> 0.015$ V	Mass airflow at idle Mass airflow during driving ECT EOT Vehicle speed for	$\leq 9.5$ g/sec $\geq 30.0$ g/sec  $> 75$ °C $> 75$ °C $> 45$ mph $> \text{Table 8}$	15 sec	2 drive cycles
Disabled DTCs						P0069 P0101 P0106 P010B P0116 P0125 P0128 P0133 P0140 P0153 P0160 P0401 P0420 P0430 P1147		

If the above table does not include details of the following enabling conditions: - IAT, ECT, vehicle speed range, and time after engine start-up then the state of these parameters has no influence upon the execution of the monitor.

**Table 8**

IAT Sensor Range Performance											
Ambient Air Temperature (°C)	-40	-30	-20	-10	0	10	20	30	40	50	60
Time (msec)	40064	40064	40064	40064	40064	9984	8064	8064	8064	8064	8064

## **4.16 Engine Oil Temperature Sensor**

### **4.16.1 Sensor Stuck**

This monitor checks that the engine oil temperature (EOT) sensor is not stuck at a particular value. If the engine has been off for greater than a calibrated and the engine speed is over a calibrated limit, then the EOT must change by a calibrated amount within a set time period after engine start, or a failure will be detected. If the EOT does change by equal to or greater than this threshold a normal judgement is made.

### **4.16.2 Range or Performance Failure**

The monitor checks that the EOT sensor is reading a correct value when compared to other sensors on the vehicle at ignition on.

If the engine has been off for greater than a calibrated time, then the EOT sensor reading is compared to the average of the sum of the ECT sensor and AAT sensor. The EOT sensor must be within a calibrated threshold of this reading for a normal judgement to be made. If it is outside this threshold then a fault will be detected.

### 4.16.3 Range/Performance Flow Chart

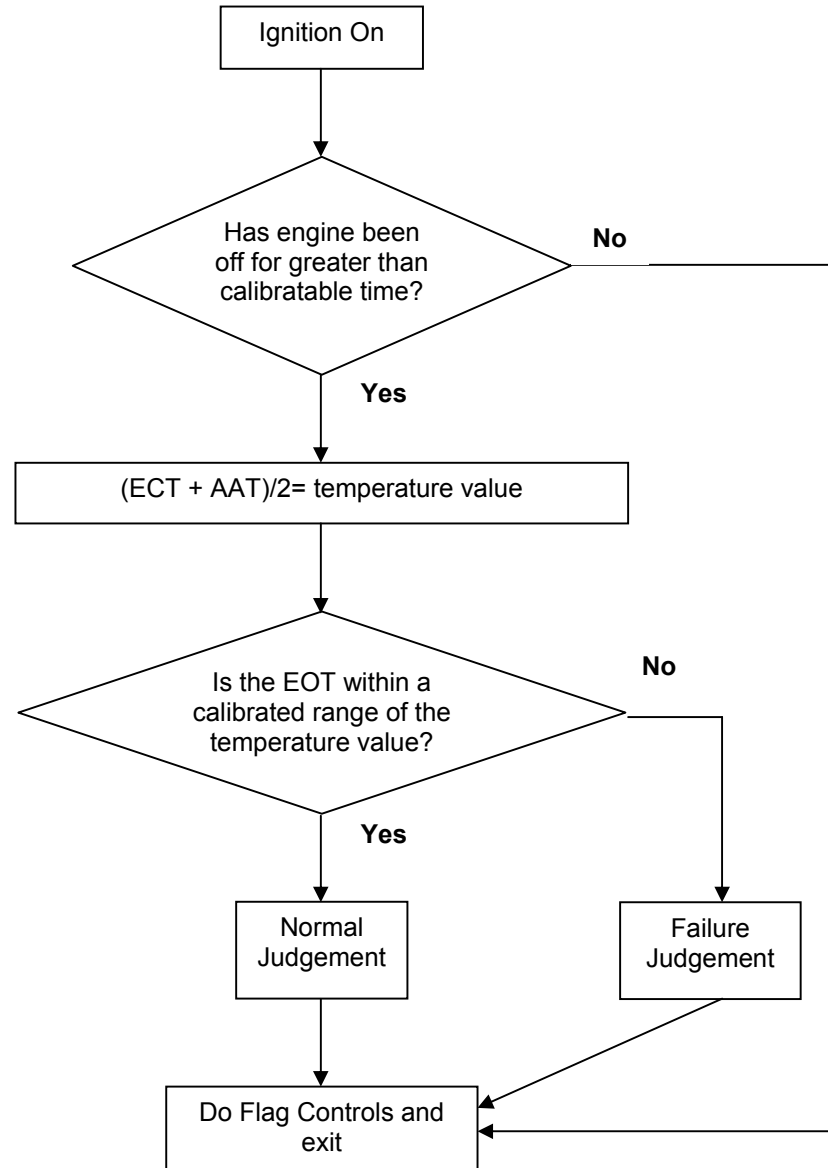

Engine Oil Temperature Sensor								
Component/ System	Fault Codes	Monitoring Strategy Description	Malfunction Criteria	Threshold value	Secondary Parameter	Enable Conditions	Time Required	MIL
EOT sensor high input	P0198	Out of range check	EOT sensor voltage	$\leq 4.61 \text{ V}$			16	2 drive cycles
EOT sensor low input	P0197	Out of range check	EOT sensor voltage	$\geq 0.03 \text{ V}$			16	2 drive cycles
EOT sensor range/ performance	P0196	Rationality versus other temperature sensors	EOT differenc with respect to average of IAT and ECT	$< 30 \text{ }^\circ\text{C}$	Engine off Difference between ECT average and ambient air temperature average Start ECT minus ECT	$> 480 \text{ minutes}$ $\leq 5^\circ\text{C}$ $\geq 4 \text{ }^\circ\text{C}$	Dependent on drive cycle	2 drive cycles
EOT sensor range/ performance	P0196	EOT sensor stuck	EOT sensor voltage movement	$> 0.015 \text{ V}$	Engine speed Engine off	$\geq 500 \text{ rpm}$ $\geq 240 \text{ minutes}$	600000 msec	2 drive cycles
P0196 Disabled DTCs						P0096 P0111 P0116 P0196		

If the above table does not include details of the following enabling conditions: - IAT, ECT, vehicle speed range, and time after engine start-up then the state of these parameters has no influence upon the execution of the monitor.



## **4.17 Fuel Rail Temperature Sensor**

### **4.17.1 Sensor Stuck**

This monitor checks that the fuel rail temperature (FRT) sensor is not stuck at a particular value. If the engine has been off for greater than a calibrated time, then the next time the engine is started the diagnostic will run.

If the engine speed is over a calibrated limit, then the fuel rail temperature must change by a calibrated amount within a set time after engine start or a failure will be flagged. If the fuel rail temperature does change by equal to or greater than this threshold a normal judgement is made.

### **4.17.2 Range or Performance Failure**

The monitor checks that the fuel rail temperature sensor is reading a correct value when compared to other sensors on the vehicle.

If the engine has been off for greater than a calibrated time period, then when the ignition is next switched on, the fuel rail temperature sensor reading is compared to the average of the sum of the ECT sensor and AAT sensor. The fuel rail temperature sensor must be within a calibrated threshold of this reading for a normal judgement to be made. If it is over this threshold, then a fault will be detected.

### 4.17.3 Range /Performance Flow Chart

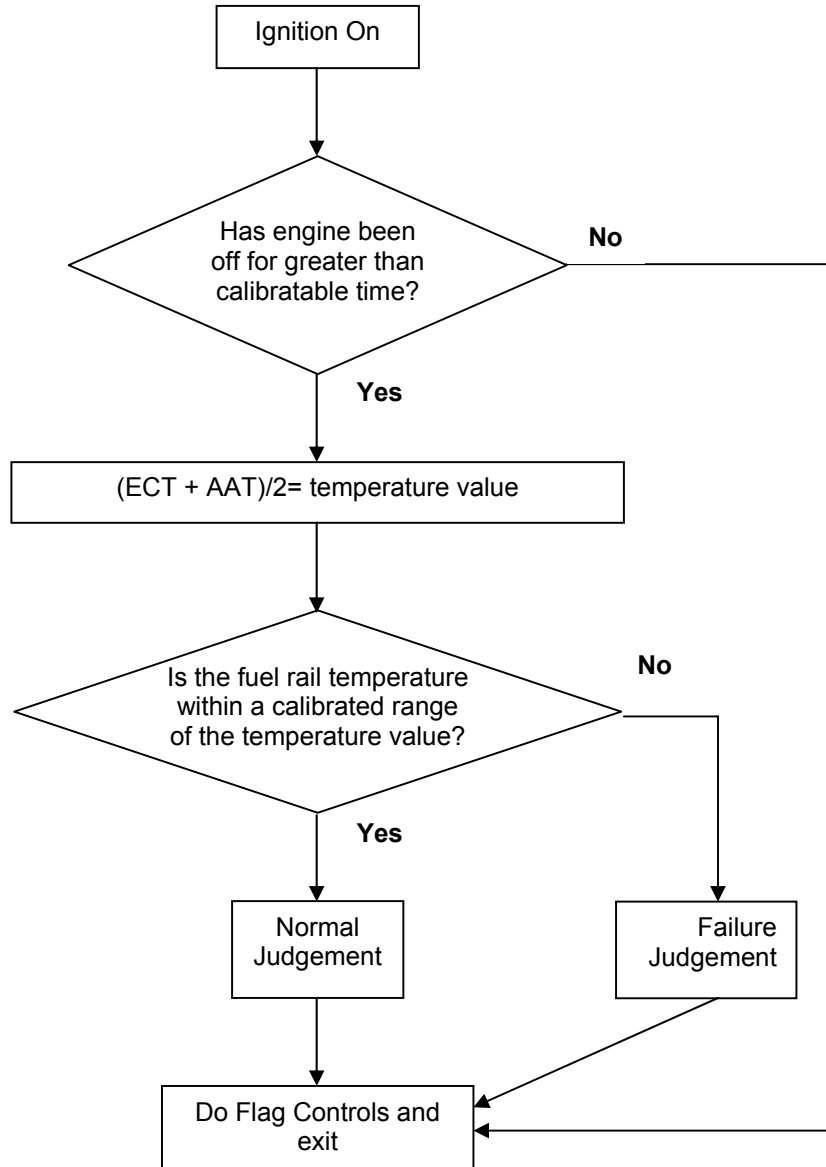

#### 4.17.4 Sensor Stuck Flow Chart

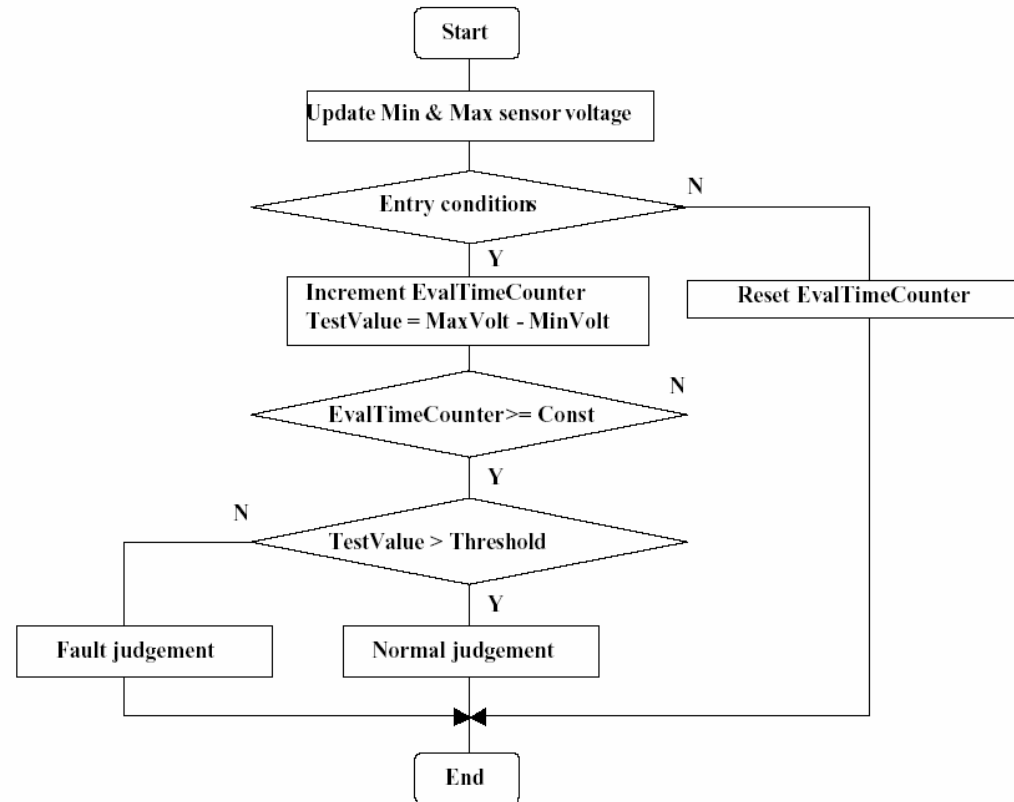

Fuel Rail Temperature Sensor								
Component/ System	Fault Codes	Monitoring Strategy Description	Malfunction Criteria	Threshold value	Secondary Parameter	Enable Conditions	Time Required	MIL
FRT sensor high input	P0183	Out of range check	FRT sensor voltage	$\leq 4.61 \text{ V}$			16	2 drive cycles
FRT sensor low input	P0182	Out of range check	FRT sensor voltage	$\geq 0.03 \text{ V}$			16	2 drive cycles
FRT sensor range / performance	P0181	Rationality	Fuel rail temperature, maximum - minimum	$> 30.0 \text{ }^\circ\text{C}$	Engine off Difference between ECT and IAT Start ECT – Current ECT	$> 480 \text{ minutes}$ $\leq 5.0 \text{ }^\circ\text{C}$ $\leq 4.0 \text{ }^\circ\text{C}$		2 drive cycles
FRT sensor range / performance	P0181	FRT sensor stuck	FRT sensor voltage	$> 0.015 \text{ V}$	Engine speed Engine off  Disabled DTCs	$\geq 500 \text{ rpm}$ $\geq 240 \text{ minutes}$  P0116 P0133 P0153 P0420 P0430	600 sec	2 drive cycles

If the above table does not include details of the following enabling conditions: - IAT, ECT, vehicle speed range, and time after engine start-up then the state of these parameters has no influence upon the execution of the monitor.

#### 4.18 Knock Sensor

When all of the entry conditions have been met, the input signals from the two knock sensors are checked against variable upper and lower threshold levels that are dependent on engine speed. If either sensor input is outside the threshold, then a failure is registered. If a failure is noted on two drive cycles then the MIL will illuminate.

Knock Sensor								
Component/ System	Fault Codes	Monitoring Strategy Description	Malfunction Criteria	Threshold value	Secondary Parameter	Enable Conditions	Time Required	MIL
Knock sensor A low input	P0327	Out of range check	Knock sensor smoothed voltage	<= Table 6	Time after start Engine speed Engine coolant temperature Engine load	>= 10 sec >= 500 rpm >= 70 °C	25 sec	2 drive cycles
Knock sensor B low input	P0332							
Knock sensor A high input	P0328	Out of range check	Knock sensor smoothed voltage	>= Table 7	Disabled DTCs None	>= Table 9	25 sec	2 drive cycles
Knock sensor B high input	P0333							

If the above table does not include details of the following enabling conditions: - IAT, ECT, vehicle speed range, and time after engine start-up then the state of these parameters has no influence upon the execution of the monitor.

**Table 6**

Knock Sensor Low Limit Threshold																
Engine Speed (rpm)	0	500	1000	1500	2000	2500	3000	3500	4000	4500	5000	5500	6000	6500	7000	7500
Voltage (V)	0.50	0.50	0.50	0.50	0.50	0.50	0.50	0.50	0.50	0.50	0.50	0.50	0.50	0.50	0.50	0.50

**Table 7**

Knock Sensor High Limit Threshold																
Engine Speed (rpm)	0	500	1000	1500	2000	2500	3000	3500	4000	4500	5000	5500	6000	6500	7000	7500
Voltage (V)	3.25	3.25	3.25	3.25	3.25	3.25	3.25	3.25	3.25	3.25	3.25	3.25	3.25	3.25	3.25	3.25

**Table 9**

Knock Sensor Load																
Engine Speed (rpm)	1000	1400	1800	2200	2600	3000	3400	3800	4200	4600	5000	5400	5800	6200	6600	7000
Engine Load (g/rev)	0.61	0.61	0.61	0.70	0.70	0.72	0.71	0.70	0.69	0.68	0.70	0.71	0.73	0.73	0.73	0.73

## 4.19 ECM Power Supplies

### 4.19.1 Description

The ECM supplies are monitored for two conditions.

The first is loss of power when the ignition is on. If the supply is not present for more than a predefined time than a failure will be registered.

The second condition is a system control relay supplying power to the ECM when it should be off. In this case, only a single occurrence of the fault will illuminate the MIL.

ECM Power Supplies								
Component/ System	Fault Codes	Monitoring Strategy Description	Malfunction Criteria	Threshold value	Secondary Parameter	Enable Conditions	Time Required	MIL
Battery Backup	P0560	Power supply out of range	Loss of battery power		Ignition switch	On	2 sec	2 drive cycles
Main relay monitor	P0687	System control relay	ECM permanently on		Battery voltage	> 8.5 V	10 sec	2 drive cycle

If the above table does not include details of the following enabling conditions: - IAT, ECT, vehicle speed range, and time after engine start-up then the state of these parameters has no influence upon the execution of the monitor.

## 4.20 Engine Control Module Self Test

### 4.20.1 Description

The ECM performs a number of self checks on both the its Random Access Memory (RAM), Read only Memory (RAM) and the two central processor units it uses to control the engine management system. A failure of any of the self-checks will require the ECM to be replaced.

Performing continuous checksum calculations and comparing the results with a stored checksum value checks the ROM. If the calculated checksum and stored checksum do not match then a ROM failure is registered. The DTC logged will depend on when the failure was identified.

A RAM test checks the RAM during ECM initialisation and shut down.

The ECM continually monitors itself for illegal internal processor operations, task being performing in the wrong order and attempts to write to the read only memory. When any of these faults are detected, P0606 will be logged.

The ECM uses two processors to perform the its calculations, the two processors are continually communicating with each other to transfer critical information. Internal diagnostic hardware continuously monitors the communication between the two processors for errors. If the level of errors exceeds a defined limit then a failure is registered.

Engine Control Module Self Test								
Component/ System	Fault Codes	Monitoring Strategy Description	Malfunction Criteria	Threshold value	Secondary Parameter	Enable Conditions	Time Required	MIL
ECM	P0604	Initial RAM test	RAM initialization			Ignition on	immediately	2 Drive Cycles
	P0604	Shut off RAM test	RAM test result			Main relay shut off	immediately	2 Drive Cycles
	P0605	Initial ROM test	ROM check sum			Ignition on	immediately	2 Drive Cycles
	P0605	Shut off ROM test	ROM check sum			Ignition off	immediately	2 Drive Cycles
	P0605	Continuous ROM test	ROM check sum			ECM running	immediately	2 Drive Cycles
	P0606	Controller test	Processor operation condition or			Ignition on	immediately	2 Drive Cycles

Engine Control Module Self Test								
Component/ System	Fault Codes	Monitoring Strategy Description	Malfunction Criteria	Threshold value	Secondary Parameter	Enable Conditions	Time Required	MIL
	P0606	Error capturing instructions	Illegal processor operation code execution or			ECM running	immediately	2 Drive Cycles
	P0606	Scheduling sequence check	Scheduling sequence or			ECM running	immediately	2 Drive Cycles
	P0606	Duplication memory fault	Mirror check result or			ECM running	immediately	2 Drive Cycles
	P0606	Detection of write to internal ROM	Illegal write to internal ROM or			ECM running	immediately	2 Drive Cycles
	P0606	Watch dog timer fault	Watch dog timer operation			ECM running	immediately	2 Drive Cycles
	P0607	Sub processor watch dog	Watch dog timer operation			ECM running	0.080 s	2 Drive Cycles
	P1600	Processor communications	Communication time out			ECM running	0.080 s	2 Drive Cycles

If the above table does not include details of the following enabling conditions: - IAT, ECT, vehicle speed range, and time after engine start-up then the state of these parameters has no influence upon the execution of the monitor.



## 4.21 Engine Starting

### 4.21.1 Crank request Signal

The crank request signal is continually monitored for the presence of a signal whilst the vehicle is in motion. Vehicle motion is confirmed by checking vehicle speed, engine speed and engine load. If the crank request signal is detected for longer than the defined time a failure is registered.

### 4.21.2 Park / Neutral Switch

During the engine crank operation if the park / neutral input is low, with the CAN signal from the transmission indicating park / neutral is selected; the low fault timer is enabled. When the low fault timer reaches the calibrated time, the low fault flag is set.

If the park / neutral input is high, and the vehicle is detected as moving with an appropriate engine load, then the high fault timer will be enabled. When the high fault timer reaches the calibrated time, the high fault flag is set.

### 4.21.3 Starter relay

The starter relay is controlled by the ECM in response to a valid crank request signal when the vehicle is stationary and park or neutral are selected. A failure of the starter relay circuit will be registered if the starter relay drive signal from the ECM is on but the starter relay feedback indicates that the relay is off.

Engine Starter								
Component/ System	Fault Codes	Monitoring Strategy Description	Malfunction Criteria	Threshold value	Secondary Parameter	Enable Conditions	Time Required	MIL
Crank request signal High Input	P0512	Crank request signal active while vehicle moving	Crank request signal	On	Vehicle speed Engine speed Engine load	$\geq 12$ mph $800 < \text{RPM} < 4000$ rpm $\geq 8.0$ g/sec	0.19 sec	2 drive cycles
Low input	P0512	Crank request not available when crank request required	Crank request signal	Off	Transmission Type Crank request Starter relay Starter relay feedback	Automatic Off Off On	0.32 sec	2 drive cycles

Engine Starter								
Component/ System	Fault Codes	Monitoring Strategy Description	Malfunction Criteria	Threshold value	Secondary Parameter	Enable Conditions	Time Required	MIL
Park / neutral switch High input	P0852	Malfunction during driving	Park neutral switch during driving	On	Transmission type Vehicle speed Engine speed Engine coolant temperature Engine load	Automatic > 9 mph 800 < RPM < 4000 rpm >= - 30 °C  >= 0.4 g/rev	0.32 sec	2 drive cycles
Low input	P0851	Malfunction during cranking	Park neutral switch during engine crank	On	Transmission type Crank request P/N input Starter relay Gear position Gear selector	Automatic On Off On Park/neutral Park/neutral	0.5 sec	2 drive cycles
Starter relay High input	P0617	Rationality relay drive circuit	Starter relay is off but starter relay driver is on	Starter relay drive on	Ignition Starter relay feedback Battery voltage	On On  > 6.56 V	0.5 sec	2 drive cycles
Low input	P0616	Rationality relay drive circuit	Starter relay is on but starter relay driver is off	Starter relay drive off	Ignition Starter relay feedback Battery voltage	On On  > 6.56 V	0.5 sec	2 drive cycles

If the above table does not include details of the following enabling conditions: - IAT, ECT, vehicle speed range, and time after engine start-up then the state of these parameters has no influence upon the execution of the monitor.

## 4.22 Accelerator Pedal Position Sensor

### 4.22.1 Description

During ignition on conditions the voltages from the two-track accelerator pedal position sensor is monitored. Both tracks are independently monitored for out of range high and low conditions.

If the input voltage to the ECM stays above a defined value for longer than a calibratable period, the high input failure judgement is made. If the input voltage to the ECM stays below a defined value for longer than a calibratable period, the low input failure judgement is made.

Additionally the signals from the two tracks are compared. If the angle obtained from sensor 1 differs from the angle obtained from sensor 2 by more than a defined amount for longer than a calibration period a range / performance failure judgement is made.

Accelerator Pedal Position Sensor								
Component/ System	Fault Codes	Monitoring Strategy Description	Malfunction Criteria	Threshold value	Secondary Parameter	Enable Conditions	Time Required	MIL
Accelerator pedal position sensor	Sensor 1 fault P0228 P0227	Out of range high	Voltage	> 4.4 V		ECM running	0.20 sec	2 drive cycles
		Out of range low	Voltage	< 0.85V		ECM running	0.20 sec	
Sensor 2 fault	P2123 P2122	Out of range high	Voltage	> 4.4 V		ECM running	0.20 sec	2 drive cycles
		Out of range low	Voltage	< 0.85 V		ECM running	0.20 sec	
Sensor 1 or 2 fault	P0229	Difference between sensors	Pedal demand	> 12.5 %	Battery voltage	ECM running > 6 V	0.20 sec	2 drive cycles

If the above table does not include details of the following enabling conditions: - IAT, ECT, vehicle speed range, and time after engine start-up then the state of these parameters has no influence upon the execution of the monitor.

## 4.23 Throttle Control System

### 4.23.1 Description

The Electronic Throttle Interface consists of 2 PWM output drives to control the throttle blade position, with 2 analogue signals for throttle position feedback. The 2 position signals have positive linear characteristics.

Throttle Control System								
Component/ System	Fault Codes	Monitoring Strategy Description	Malfunction Criteria	Threshold value	Secondary Parameter	Enable Conditions	Time Required	MIL
Throttle difference	P2101	Difference between actual throttle position and requested	Throttle angle	> 5%	Battery voltage Throttle adaption	ECM running 6 < B+ < 18 V Throttle offset adaption complete For large deviation	0.224 sec	2 drive cycles
Throttle assembly fault	P2103	Throttle duty 100% continuous	Time	> 2.0 sec	No fault flag	ECM running Fault flag not set in main or sub processors	2.0 sec	2 drive cycles
	P2118	Over current fault detected by throttle driver hardware	Current. time	> 0.16 sec	No fault flag	ECM running Ignition On Fault flag not set in main or sub processor	0.16 sec	2 drive cycles
Spring fault	P2119	Limp home spring and throttle return springs functional check	Throttle Angle	> 4%	Battery voltage Throttle adaption	> 9 V Throttle offset adaption complete No over current fault flag	N/A	2 drive cycles

Throttle Control System								
Component/ System	Fault Codes	Monitoring Strategy Description	Malfunction Criteria	Threshold value	Secondary Parameter	Enable Conditions	Time Required	MIL
Throttle sensor difference between processors	P060E	Difference fault between throttle sensor in main processor and sub processor Or 4x amplified throttle position sensor fault functional check	Throttle voltage	> 0.0440 V	Throttle offset adaption	ECM running Complete For large deviations	64 msec	2 drive cycles
			Voltage	0.22 V	TP Sensor 1 voltage Battery voltage	0.298 to 1.152 V 6 to 18 V Ignition On	96 msec	2 drive cycles
Throttle position sensor 1	P0123	TP sensor 1 out of range high	Voltage	> 4.742 V		Ignition On	24 msec	2 drive cycles
	P0122	TP sensor 1 out of range low	Voltage	< 0.420 V		Ignition on	24 msec	2 drive cycles
Throttle position sensor 2	P0223	TP sensor 2 out of range high	Voltage	> 4.80 V		Ignition On	24 msec	2 drive cycles
	P0222	TP sensor 2 out of range low	Voltage	< 1.229 V		Ignition on	24 msec	2 drive cycles
Throttle position sensor difference	P0121	Difference between TP sensor 1 and 2	Throttle angle (%)	> 7.34 %	Throttle offset adaption Throttle adaption value 1 Throttle adaption value 2	Complete 0.503 to 0.697 V 1.208 to 1.725 V	12 msec	2 drive cycles

If the above table does not include details of the following enabling conditions: - IAT, ECT, vehicle speed range, and time after engine start-up then the state of these parameters has no influence upon the execution of the monitor.

## 4.24 Torque Monitoring

### 4.24.1 Description

The Engine Torque control is monitored to ensure that there is no large unintended Torque greater than requested by the driver. This monitor consists of an independent engine Torque measurement and engine speed monitor in idle speed control.

Torque Monitoring								
Component/ System	Fault Codes	Monitoring Strategy Description	Malfunction Criteria	Threshold value	Secondary Parameter	Enable Conditions	Time Required	MIL
Engine torque fault	P061A	Compare allowed engine torque against actual torque	Torque	20 Nm		Engine Running	0.500 sec	2 drive cycles
Pedal follower fault	P061A	Monitor for excess throttle position with respect to demand	Throttle angle	0.1 %		Engine Running	0.500 sec	2 drive cycles

If the above table does not include details of the following enabling conditions: - IAT, ECT, vehicle speed range, and time after engine start-up then the state of these parameters has no influence upon the execution of the monitor.

## 4.25 Vehicle Speed Signal

### 4.25.1 Description

Two checks are performed on the vehicle speed.

The first check is for loss of any of the ABS wheel speed sensor signals. If any of the wheel speed sensor signals are not supplied for longer than the predefined time then a failure is registered

The second check compares the vehicle speed transmitted by the ABS control module and the vehicle speed calculated by the ECM using the data from the transmission output shaft speed sensor. If the transmitted and calculated speed signals do not match for longer than a predefined time then a failure is registered.

Vehicle Speed Signal								
Component/ System	Fault Codes	Monitoring Strategy Description	Malfunction Criteria	Threshold value	Secondary Parameter	Enable Conditions	Time Required	MIL
Vehicle speed input	P0500	Driven wheel speed sensor fault	Failure of 1 or more wheel speed signals				96 msec	2 drive cycles
Vehicle speed rationality	P0501	Comparison of ABS vehicle speed and calculated speed	ABS vehicle speed - Vehicle speed	10 % error	Engine speed rate of change Output shaft speed TCM, Stability control system Battery voltage	> 12 mph  550 <= OSS <= 7300 rpm OK  > 10.5 V		2 drive cycles
Vehicle speed Transmission	P0721	Transmission output shaft speed fault						

If the above table does not include details of the following enabling conditions: - IAT, ECT, vehicle speed range, and time after engine start-up then the state of these parameters has no influence upon the execution of the monitor.

## 4.26 Fuel Injectors

### 4.26.1 Description

The injector monitor operates on a continuous basis. Open and short detection of each injector is possible by comparing the actual injection signal with a target injection signal. The actual injection signal is derived from a change in injector voltage when the injector is turned off and the target injection signal is derived from an injection set flag.

A normal judgement is made when the injector voltage moves from the on to off position i.e. on the signal edge. If the target signal and the actual signal are both set to one, a normal judgement is made. This process is repeated for each injector in firing order. A failure judgement is made when no injector signal edge is detected i.e. no change in voltage but the injector has been triggered.

Fuel Injectors								
Component/ System	Fault Codes	Monitoring Strategy Description	Malfunction Criteria	Threshold value	Secondary Parameter	Enable Conditions	Time Required	MIL
Cylinder 1 Injector circuit	P0201	Drive hardware check	Command versus actual	Different			200 firing cycles	2 Drive cycles
Cylinder 2 Injector circuit	P0202	Drive hardware check	Command versus actual	Different				2 Drive cycles
Cylinder 3 Injector circuit	P0203	Drive hardware check	Command versus actual	Different				2 Drive cycles
Cylinder 4 Injector circuit	P0204	Drive hardware check	Command versus actual	Different				2 Drive cycles
Cylinder 5 Injector circuit	P0205	Drive hardware check	Command versus actual	Different				2 Drive cycles
Cylinder 6 Injector circuit	P0206	Drive hardware check	Command versus actual	Different				2 Drive cycles
								Disabled DTCs

If the above table does not include details of the following enabling conditions: - IAT, ECT, vehicle speed range, and time after engine start-up then the state of these parameters has no influence upon the execution of the monitor.



## 4.27 Ignition Amplifiers / Coils

### 4.27.1 Description

The ignition amplifiers monitor is very similar in operation to the injectors monitor, albeit checking primary coil current instead of voltage.

Internal hardware detection circuits in the ECM, monitor the individual and group outputs to the coil primaries for incorrect current conditions. If a failure is repeatedly noted over a predefined number of engine revolutions then a failure of the appropriate coil or group circuit is registered. If the failure is registered on 2 drive cycles then the MIL will illuminate.

Ignition Amplifiers / Coils								
Component/ System	Fault Codes	Monitoring Strategy Description	Malfunction Criteria	Threshold value	Secondary Parameter	Enable Conditions	Time Required	MIL
Cylinder 1 malfunction	P0351	Drive hardware check	Primary coil current- no discharge spike		Battery voltage Engine speed	>= 10.5 V <= 2500 rpm	2 times	2 Drive cycles
Cylinder 2 malfunction	P0352	Drive hardware check	Primary coil current- no discharge spike					2 Drive cycles
Cylinder 3 malfunction	P0353	Drive hardware check	Primary coil current- no discharge spike					2 Drive cycles
Cylinder 4 malfunction	P0354	Drive hardware check	Primary coil current- no discharge spike					2 Drive cycles
Cylinder 5 malfunction	P0355	Drive hardware check	Primary coil current- no discharge spike					2 Drive cycles
Cylinder 6 malfunction	P0356	Drive hardware check	Primary coil current- no discharge spike					2 Drive cycles
Ignition amplifier group 1	P1367	Drive hardware check	Primary coil current- no discharge spike					2 Drive cycles
Ignition amplifier group 2	P1368	Drive hardware check	Primary coil current- no discharge spike					2 Drive cycles
					Disabled DTCs	P0125 P0128 P0133 P0140 P0153 P0160 P0420 P0430		

If the above table does not include details of the following enabling conditions: - IAT, ECT, vehicle speed range, and time after engine start-up then the state of these parameters has no influence upon the execution of the monitor.

## 4.28 Variable Valve Timing

The system comprises of an actuator built into the camshaft chain sprocket and an oil control valve which controls the flow of oil to the camshaft actuator. Control of the system is done via the oil control valve and camshaft position sensors. The oil control valve varies the oil flow into the camshaft actuator and creates a variable offset between the camshaft and the camshaft sprocket, feedback for this system is provided by the camshaft position sensors. Variable valve timing is only fitted to naturally aspirated engines.

### 4.28.1 Hardware Check

This monitor checks the oil control valve on both banks 1 and 2. The commanded and actual state of the oil control valve are continually checked as long as the PWM drive signal remains within limits. If the commanded and actual state of the oil control valve differ for longer than a predefined time period then a failure is registered. The ECM determines the type of failure by examining which state the valve was unable to attain and the output signal to the valve. If a failure is registered on 2 drive cycles, the MIL will illuminate.

### 4.28.2 Camshaft Position

The camshaft position sensors are used to monitor the actual level of camshaft advance / retard against the target level. If the target and actual values do not match a failure is registered. If a failure is registered on 2 drive cycles, the MIL will illuminate.

### 4.28.3 Camshaft Adaption

The adaption values for the camshaft position on this trip are compared to the adaption values from the last trip. If the adaption values vary by more than a defined amount a failure is registered and the MIL is illuminated.

Variable Valve Timing								
Component/ System	Fault Codes	Monitoring Strategy Description	Malfunction Criteria	Threshold value	Secondary Parameter	Enable Conditions	Time Required	MIL
<b>VVT Actuator Monitoring</b> Electrical fault bank 1(short to B+) Electrical fault bank 1(short to	P0077  P0076	Hardware check	Command versus actual	Different	Oil control valve duty cycle	5 < PWM < 95 %	1 second	2 Drive Cycles  2 Drive Cycles

Variable Valve Timing								
Component/ System	Fault Codes	Monitoring Strategy Description	Malfunction Criteria	Threshold value	Secondary Parameter	Enable Conditions	Time Required	MIL
ground) Electrical fault bank 1(open circuit)	P0075							2 Drive Cycles
Electrical fault bank 2(short to B+)	P0083							2 Drive Cycles
Electrical fault bank 2(short to ground)	P0082							2 Drive Cycles
Electrical fault bank 2(open circuit)	P0081							2 Drive Cycles
					Disable DTCs	P0101 P0106 P010B P0133 P0140 P0153 P0160 P0401 P0420 P0430		
<b>VVT Monitoring</b> Intake Range Performance High – Bank 1	P0026	Actual position compared to target	Difference too great	>= 20 deg. crank angle	Target angle deviation	<= 2 deg. crank angle per 64 msec 0 < ECT < 120 °C	10 seconds	2 drive cycles
Intake Range Performance High – Bank 2	P0028			<= 20 deg. crank angle	Engine coolant temperature			2 drive cycles
Intake Range Performance Low – Bank 1	P0026							2 drive cycles
Intake Range Performance Low – Bank 1	P0028							2 drive cycles
					Disabled DTCs	P0101 P0106 P010B P0133 P0140 P0153 P0160 P0401 P0420 P0430		
<b>Camshaft / crankshaft alignment check</b>								

Variable Valve Timing								
Component/ System	Fault Codes	Monitoring Strategy Description	Malfunction Criteria	Threshold value	Secondary Parameter	Enable Conditions	Time Required	MIL
Intake retard position fault – Bank 1(high)	P0011	This trip Camshaft adaption compared to last	Difference too great (+/-)	>= 10 deg. Crank angle	Atmospheric pressure	>= 68.0 kPa >= -30.0 °C <= -30.0 °C  Done		1 drive cycle
Intake retard position fault – Bank 2(high)	P0021				Ambient temperature			1 drive cycle
Intake advance position fault – Bank 1(low)	P0012				Engine coolant temperature			1 drive cycle
Intake advance position fault – Bank 2(low)	P0022				Camshaft adaption for this trip			1 drive cycle
					Disabled DTCs	P0134 P0154 P2096 P2097 P2098 P2099 P0420 P0430		

If the above table does not include details of the following enabling conditions: - IAT, ECT, vehicle speed range, and time after engine start-up then the state of these parameters has no influence upon the execution of the monitor.

#### 4.29 Cold Start Emission Reduction Strategy

Once all entry conditions have been met this monitor performs two tests

The first checks the actual engine speed against the target idle speed. If the ECM is unable to achieve a high enough idle speed ( actual idle speed lower than target idle speed by more than 100 rpm) then a failure will be registered.

The second check compares the actual spark timing against a predefined target. If the spark timing is too far advanced then a failure will be registered.

In both instances should the failure be detected on two consecutive drive cycles the MIL will be illuminated.

Cold Start Emission Reduction Strategy Performance								
Component/ System	Fault Codes	Monitoring Strategy Description	Malfunction Criteria	Threshold value	Secondary Parameter	Enable Conditions	Time Required	MIL
Engine speed performance – too low	P0506	Actual engine speed compared to target	Engine speed lower than expected by	>= 100 rpm	Idle speed control active Idle speed increase for catalyst heating Time after start Atmospheric pressure Ambient temperature Engine coolant temperature Vehicle speed Low volatility gasoline compensation Time since gearshift D-N (or P), brake switch state change or AC clutch state change Disabled DTCs	>= 29952 msec  TBC 9984 to 25025 msec >= 68 kPa >= -30.0 °C 5.0 to 70.0 °C  <= 2.0 mph <= 50.0 %  >= 2048 msec  P0128	5 sec	2 drive cycles

Cold Start Emission Reduction Strategy Performance								
Component/ System	Fault Codes	Monitoring Strategy Description	Malfunction Criteria	Threshold value	Secondary Parameter	Enable Conditions	Time Required	MIL
Spark timing performance - too advanced	P050B	Actual spark timing compared to target	Spark timing more advanced than required	< TBC	Idle speed control Catalyst heating torque reserve Time after start  Atmospheric pressure Ambient temperature Engine coolant temperature Vehicle speed Vehicle speed change in 32 msec Disabled DTCs	Active >= TBC  9984 to 25025 msec >= 68.0 kPa >= -30.0 °C 50.0 to 5.0 °C  <= 2.0 mph <= TBC	TBC	2 drive cycles
						P0128		

If the above table does not include details of the following enabling conditions: - IAT, ECT, vehicle speed range, and time after engine start-up then the state of these parameters has no influence upon the execution of the monitor.

### 4.30 Secondary Air Injection System

Observing the system pressure at several instances during its cycle of operation monitors the secondary air injection system.

The system pressure is measured before operation of the pump. The pump is then switched on simultaneously with the opening of the check valve. After a delay to allow the system to stabilise, the system pressure is measured again, this time by taking the average of a 1-second duration of readings, and normalising for variations in battery voltage and atmospheric pressure.

A second pressure measurement is made after the requirement for secondary air injection into the exhaust system has expired, but continuing on from the same period of pump operation, i.e. the pump is left running, against a closed check valve. Again this pressure measurement is the average of a 1-second duration of readings normalised for variations in battery voltage and atmospheric pressure. If the system pressure measured at this time has not risen enough or has risen too much with respect to the system pressure during normal operation of secondary air injection then a failure will be flagged.

This strategy can detect a single point failure anywhere in the system as shown below:

measurement name	Ps	Pc
measurement instance	during normal flow	pumping against closed valve

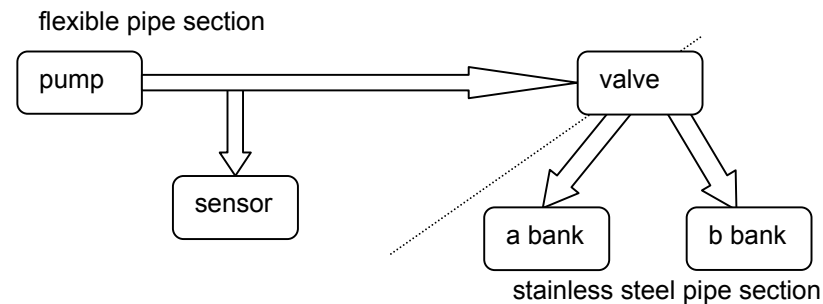

Component	Failure type	Detected by
air pump	stuck off	pressure difference between normal flow and closed valve reading too low ( $P_c - P_s$ too low)
	stuck on	pressure difference between normal flow and closed valve reading too low ( $P_c - P_s$ too low)
	flow deterioration – less air pumped	pressure difference between normal flow and closed valve reading too low, ( $P_c - P_s$ too low)
check valve	stuck closed	pressure difference between normal flow and closed valve reading too low ( $P_c - P_s$ too low)
	stuck open	pressure difference between normal flow and closed valve reading too low ( $P_c - P_s$ too low)
	flow deterioration – restriction in valve	pressure difference between normal flow and closed valve reading too low ( $P_c - P_s$ too low)
flexible pipe	disconnect between pump and sensor	pressure difference between normal flow and closed valve reading too low ( $P_c - P_s$ too low)
	disconnect between sensor and valve	pressure difference between normal flow and closed valve reading too low ( $P_c - P_s$ too low)
	blockage upstream of pump	pressure difference between normal flow and closed valve reading too low ( $P_c - P_s$ too low)
	blockage downstream of pump	pressure difference between normal flow and closed valve reading too low ( $P_c - P_s$ too low)
stainless steel pipes	disconnect between valve and manifold (bank a)	pressure difference between normal flow and closed valve reading too high ( $P_c - P_s$ too high)
	disconnect between valve and manifold (bank b)	pressure difference between normal flow and closed valve reading too high ( $P_c - P_s$ too high)
	blockage between valve and manifold (bank a)	pressure difference between normal flow and closed valve reading too low ( $P_c - P_s$ too low)
	blockage between valve and manifold (bank b)	pressure difference between normal flow and closed valve reading too low ( $P_c - P_s$ too low)



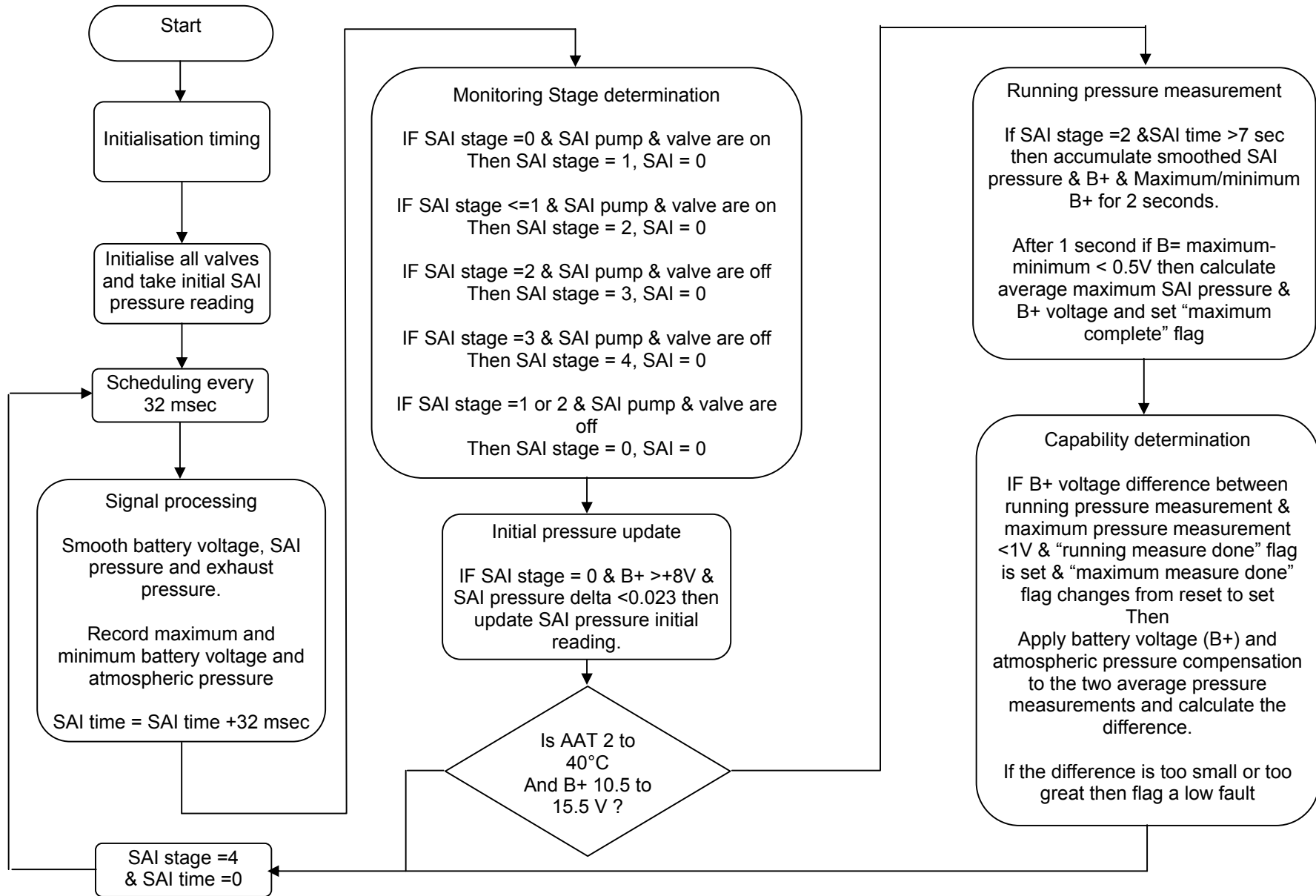

Secondary Air Injection System								
Component/ System	Fault Codes	Monitoring Strategy Description	Malfunction Criteria	Threshold value	Secondary Parameter	Enable Conditions	Time Required	MIL
<b>SAI System performance</b> Pump stuck off  Pump stuck on  Pump performance	P0411  P2444  P2445	System pressure does not rise System pressure does not fall  Difference between system pressure during normal operation and when pumping against closed check valve	Pressure rise too small Pressure too great compared to atmospheric pressure Outside Limits	<= Map 4  >= Map 5  <= Table 2 >= Table 3	SAI active Atmospheric pressure Atmospheric pressure change during monitor Ambient temperature Battery voltage (B+) Battery voltage change during monitor Battery voltage change during measurement Exhaust pressure Disabled DTCs	>= 9 sec >= 74.5 kPa <= 0.3 kPa  2 to 40 °C 10.5 to 14.5 V <= 0.5 V  <= 0.2 V  <= 130.0 kPa none	At least 9 seconds	2 drive cycles 2 drive cycles  2 drive cycles
<b>SAI Valve</b> Circuit continuity – short to ground Circuit continuity – short to B+	P0414  P0413	Hardware check	Commanded v Actual	Different	      Disabled DTCs	      P0133 P0153	4992 msec	2 drive cycles 2 drive cycles
<b>SAI Pump relay</b> Circuit continuity – short to ground Circuit continuity – short to B+	P2444  P2445	Hardware check	Commanded v Actual	Different	      Disabled DTCs	      P0133 P0153	4992 msec	2 drive cycles 2 drive cycles
<b>SAI Pressure sensor</b> Sensor high input  Sensor low input  Sensor range /	P2433  P2432  P2431	Out of range check Out of range check  Comparison with	Sensor voltage Sensor voltage  Difference (+/-)	>= 4.80 V  <= 0.20 V  > 10.0 kPa	Battery voltage (B+) Time after ignition on Time after secondary air injection operation	>= 7.0 V >= 256 msec >= 4992 ms	16  16  512 msec	2 drive cycles 2 drive cycles  2 Drive

Secondary Air Injection System								
Component/ System	Fault Codes	Monitoring Strategy Description	Malfunction Criteria	Threshold value	Secondary Parameter	Enable Conditions	Time Required	MIL
performance		barometric pressure sensor						cycles

If the above table does not include details of the following enabling conditions: - IAT, ECT, vehicle speed range, and time after engine start-up then the state of these parameters has no influence upon the execution of the monitor.

#### Map 4

Secondary air Injection Pump Stuck Off				
x-axis units	kPa			
y-axis units	V			
Data units	kPa			
	72.6	81.5	91.2	102.6
10.5	1.0	1.0	1.0	1.0
11.5	1.0	1.0	1.0	1.0
12.5	1.0	1.0	1.0	1.0
13.5	1.0	1.0	1.0	1.0
14.5	1.0	1.0	1.0	1.0
15.5	1.0	1.0	1.0	1.0
16.5	1.0	1.0	1.0	1.0
17.5	1.0	1.0	1.0	1.0

**Map 5**

Secondary air Injection Pump Stuck On				
x-axis units	kPa			
y-axis units	V			
Data units	kPa			
	72.6	81.5	91.2	102.6
10.5	82.6	91.5	101.2	112.6
11.5	82.6	91.5	101.2	112.6
12.5	82.6	91.5	101.2	112.6
13.5	82.6	91.5	101.2	112.6
14.5	82.6	91.5	101.2	112.6
15.5	82.6	91.5	101.2	112.6
16.5	82.6	91.5	101.2	112.6
17.5	82.6	91.5	101.2	112.6

**Table 2**

Secondary air Injection Pump Performance (minimum)							
x-axis units	°C						
Data units	kPa						
-10	0	10	20	30	40	50	60
1.00	1.00	1.00	1.00	1.00	1.00	1.00	1.00

**Table 3**

Secondary air Injection Pump Performance (maximum)							
x-axis units	°C						
Data units	kPa						
-10	0	10	20	30	40	50	60
5.00	5.00	5.00	5.00	5.00	5.00	5.00	5.00

### 4.31 Controller Area Network System

The Controller area network (CAN) system is monitored by the ECM for the following conditions.

#### 4.31.1 Invalid signal Error

The ECM is continually receiving data from a number of other control modules via the CAN system. If one of these control modules identifies a problem within its own system that causes it to be unable to transmit valid data, it will store a DTC locally and transmit an error marker (a specific default value of the data that indicates an error) on to the CAN system. When the ECM identifies an error marker from another control module, it also logs a failure.

#### 4.31.2 Loss of Communications

All of the control modules on the CAN system transmit data continually. If messages from one or more of the control modules are not seen by the ECM within a predefined time, it will register a loss of communications failure.

CAN System								
Component/ System	Fault Codes	Monitoring Strategy Description	Malfunction Criteria	Threshold value	Secondary Parameter	Enable Conditions	Time Required	MIL
Invalid external ambient air temperature signal	U0424	Rear climate control module fault across CAN	Rear climate control module transmits fault flag			Continuous	5 sec	2 drive cycles
Invalid actual gear position status signal	U0402	TCM fault across CAN	TCM transmits fault flag			Continuous	5 sec	2 drive cycles
Invalid gear selector status signal	U0402	TCM fault across CAN	TCM transmits fault flag			Continuous	5 sec	2 drive cycles
Output shaft speed signal	U0402	TCM fault across CAN	TCM transmits fault flag			Continuous	5 sec	2 drive cycles

CAN System								
Component/ System	Fault Codes	Monitoring Strategy Description	Malfunction Criteria	Threshold value	Secondary Parameter	Enable Conditions	Time Required	MIL
Wheel speed signal (front left)	C0031	ABS fault across CAN	ABS transmits fault flag			Continuous	5 sec	2 drive cycles
Wheel speed signal (front right)	C0034	ABS fault across CAN	ABS transmits fault flag			Continuous	5 sec	2 drive cycles
Wheel speed signal (rear left)	C0037	ABS fault across CAN	ABS transmits fault flag			Continuous	5 sec	2 drive cycles
Wheel speed signal (rear right)	C003A	ABS fault across CAN	ABS transmits fault flag			Continuous	5 sec	2 drive cycles
Lost communication with the ABS control module	U0121	CAN signals missing from ABS control module	ABS CAN identifier not received	No identifier	Ignition Battery voltage Engine crank Initialisation timer	On > 10.49 V Not requested > 0.512 sec	3.3 sec	2 drive cycles
Lost communication with the Transmission control module	U0101	CAN signals missing from TCM	TCM CAN identifier not received	No identifier	Ignition Battery voltage Engine crank Initialisation timer	On > 10.49 V Not requested > 0.512 sec	3.3 sec	2 drive cycles
Lost communication with the Instrument pack	U0155	CAN signals missing from instrument pack	Instrument pack CAN identifier not received	No identifier	Ignition Battery voltage Engine crank Initialisation timer	On > 10.49 V Not requested > 0.512 sec	3.3 sec	2 drive cycles
Lost communication with the air conditioning control module	U0164	CAN signals missing from A?C control module	Air conditioning CAN identifier not received	No identifier	Ignition Battery voltage Engine crank Initialisation timer	On > 10.49 V Not requested > 0.512 sec	3.3 sec	2 drive cycles

If the above table does not include details of the following enabling conditions: - IAT, ECT, vehicle speed range, and time after engine start-up then the state of these parameters has no influence upon the execution of the monitor.

### 4.32 Fuel Level Sensor

The fuel level is monitored continuously. The fuel level should change by more than a set percentage before a calculated amount of fuel is used. This process will operate through cumulative trips if necessary. Once the fuel level changes by the amount required the process is reset and begins again. If the fuel used threshold is reached before the fuel level changes by the required percentage, a fault will be stored.

Fuel Level Sensor								
Component/ System	Fault Codes	Monitoring Strategy Description	Malfunction Criteria	Threshold value	Secondary Parameter	Enable Conditions	Time Required	MIL
Range/ performance	P0461	Rationality versus fuel used	Fuel level change	< 3%	Fuel used (calculated) Time after start Battery voltage Disable DTCs	>= 19.9 Litre >= 0 sec 10.5 < B+ < 16 V None	Dependent upon drive cycle	No MIL

If the above table does not include details of the following enabling conditions: - IAT, ECT, vehicle speed range, and time after engine start-up then the state of these parameters has no influence upon the execution of the monitor.

### 4.33 Engine Off Timer

#### 4.33.1 Description

The engine off timer monitor checks rationality against the behaviour of the ECT sensor since the key was turned off.

Engine Off Timer								
Component/ System	Fault Codes	Monitoring Strategy Description	Malfunction Criteria	Threshold value	Secondary Parameter	Enable Conditions	Time Required	MIL
Engine off timer range / performance	P2610	Rationality with respect to ECT behavior since key off	Engine off Time	> TBC < TBC	ECT at end of last trip  Disabled DTCs	80 °C to 120 °C  None		2 drive cycles

If the above table does not include details of the following enabling conditions: - IAT, ECT, vehicle speed range, and time after engine start-up then the state of these parameters has no influence upon the execution of the monitor.



## 4.34 Ambient Air Temperature

### 4.34.1 Description

The ambient air temperature signal is supplied by the instrument pack. The ECM performs two diagnostic checks on the signal.

#### Rationality Check

The signal is checked for rationality against the IAT sensor. When the entry conditions have been met the difference between the sensors is checked, if this is greater than the threshold for a predefined period then a failure is registered. If the problem occurs on two drive cycles then the MIL will illuminate. Which DTC logs depends on whether the ambient air temperature sensor signal is lower or higher than the intake air temperature sensor.

Ambient Air Temperature								
Component/ System	Fault Codes	Monitoring Strategy Description	Malfunction Criteria	Threshold value	Secondary Parameter	Enable Conditions	Time Required	MIL
AAT sensor stuck high AAT sensor stuck low	P0073 P0072	Rationality with IAT sensor	Difference between IAT and AAT	> 30.0 °C	Vehicle speed  Mass airflow  Disabled DTCs	> 45 mph  > 30 g/sec  P0101 P0106 P010B P0125 P0128 P0133 P0140 P0153 P0160 P0401 P0420 P0430	15 sec	2 drive cycles

If the above table does not include details of the following enabling conditions: - IAT, ECT, vehicle speed range, and time after engine start-up then the state of these parameters has no influence upon the execution of the monitor.

### 4.35 Intake Manifold Tuning Valve System

When the entry conditions have been met, the control module checks the commanded versus actual position of the IMT valves. If they are not matched, a timer is started. If at the end of the set time the commanded and actual positions of the IMT valves do not match then the relevant DTC is flagged and the IMT valve affected is disabled.

Intake Manifold Tuning Valve								
Component/ System	Fault Codes	Monitoring Strategy Description	Malfunction Criteria	Threshold value	Secondary Parameter	Enable Conditions	Time Required	MIL
Valve 1 low/high input	P0661 P0662	Hardware check	Commanded versus actual	Different	Duty Cycle	4.7 to 95%	10s	2 DTC
Valve 2 low/high input	P0664 P0665	Hardware check	Commanded versus actual	Different	Duty Cycle	4.7 to 95%	10s	2 DTC

If the above table does not include details of the following enabling conditions: - IAT, ECT, vehicle speed range, and time after engine start-up then the state of these parameters has no influence upon the execution of the monitor.