



FORD MOTOR CO. 5R55N

INDEX

<i>5R55N TRANSMISSION IDENTIFICATION</i>	3
<i>COMPONENT APPLICATION CHART</i>	4
<i>SOLENOID APPLICATION AND RESISTANCE CHARTS</i>	5
<i>SOLENOID BODY PIN IDENTIFICATION</i>	6
<i>GENERAL DESCRIPTION AND OPERATION</i>	7
<i>MANUAL SHIFT SELECTOR OPERATION</i>	9
<i>ELECTRONIC COMPONENT LOCATER CHART</i>	11
<i>AUXILLIARY JUNCTION BOX RELAY LOCATIONS</i>	12
<i>CENTRAL JUNCTION BOX FUSE LOCATIONS</i>	13
<i>VARIOUS CONNECTOR AND PIN IDENTIFICATION</i>	14
<i>WIRING SCHEMATIC</i>	15
<i>TRANSMISSION COMPONENT RESISTANCE CHART THROUGH PCM CONNECTOR</i>	17
<i>DIGITAL TRANSMISSION RANGE SENSOR</i>	18
<i>DIAGNOSTIC TROUBLE CODE CHART AND DESCRIPTION</i>	19
<i>LINE PRESSURE TESTS</i>	22
<i>TRANSMISSION DISASSEMBLY</i>	23
<i>COMPONENT REBUILD SECTION</i>	
<i>OIL PUMP ASSEMBLY</i>	42
<i>COAST CLUTCH HOUSING</i>	46
<i>OVERDRIVE CARRIER AND OVERDRIVE SPRAG ASSEMBLY</i>	50
<i>DIRECT CLUTCH HOUSING</i>	52
<i>FORWARD CLUTCH HOUSING</i>	57
<i>CENTER SUPPORT ASSEMBLY</i>	61
<i>LOW SPRAG AND REVERSE DRUM ASSEMBLY</i>	62
<i>REAR RING GEAR AND HUB ASSEMBLY</i>	62
<i>FRONT AND REAR PLANETARY CARRIER ASSEMBLY</i>	64
<i>INTERMEDIATE SPRAG ASSEMBLY</i>	65
<i>VALVE BODY ASSEMBLY</i>	73
<i>REVERSE SERVO ASSEMBLY</i>	76
<i>TRANSMISSION CASE ASSEMBLY</i>	79
<i>EXTENSION HOUSING AND PARKING PAWL ASSEMBLY</i>	82
<i>FINAL TRANSMISSION ASSEMBLY</i>	86
<i>REAR END CLEARANCE PROCEDURES</i>	91
<i>FRONT END CLEARANCE PROCEDURES</i>	97
<i>BOLT SIZE AND LENGTH CHART</i>	111
<i>CHECKING FLUID LEVEL</i>	112
<i>COOLER LINE IDENTIFICATION</i>	112
<i>SPECIAL SERVICE TOOLS</i>	114
<i>TORQUE SPECIFICATIONS</i>	116
<i>REVISED CHECK-BALL LOCATIONS</i>	118

AUTOMATIC TRANSMISSION SERVICE GROUP

18639 S.W. 107TH AVENUE

MIAMI, FLORIDA 33157

(305) 670-4161

Copyright © ATSG 2001



INTRODUCTION FORD 5R55N

*Revised
April, 2004*

This booklet contains general description and overhaul procedures necessary to repair, overhaul or service the new Ford Motor Co 5R55N transmission. The Ford 5R55N transmission was first introduced in the 2000 model year, and is currently found in the Lincoln "LS" and Jaguar X200. We wish to thank Ford Motor Company for the information and illustrations that have made this booklet possible.

The 5R55N transmission has 5 forward speeds, reverse and is fully electronic controlled. Internally, it looks *similar* to the previous 5R55E unit, but very few minor components are actually the same. Following are the internal components used in the new 5R55N transmission.

- *3 Planetary Compound Gear Sets: Overdrive, Forward and Rear.*
- *3 Brake Bands: Overdrive, Intermediate and Low/Reverse.*
- *4 Multi-Plate Clutch Packs: Coast, Forward, Direct and Intermediate.*
- *3 One-Way Clutches: Overdrive, Intermediate and Low.*
- *Electronic Controlled Shifts, Torque Converter Clutch and Pressure.*

No part of any ATSG publication may be reproduced, stored in any retrieval system or transmitted in any form or by any means, including but not limited to electronic, mechanical, photocopying, recording or otherwise, without *written* permission of Automatic Transmission Service Group. This includes all text illustrations, tables and charts.

The information and part numbers contained in this booklet have been carefully compiled from industry sources known for their reliability, but ATSG does not guarantee its accuracy.

Copyright © ATSG 2004

DALE ENGLAND
FIELD SERVICE CONSULTANT

WAYNE COLONNA
TECHNICAL SUPERVISOR

PETER LUBAN
TECHNICAL CONSULTANT

JON GLATSTEIN
TECHNICAL CONSULTANT

ROLAND ALVAREZ
TECHNICAL CONSULTANT

GERALD CAMPBELL
TECHNICAL CONSULTANT

JIM DIAL
TECHNICAL CONSULTANT

ED KRUSE
TECHNICAL CONSULTANT

GREGORY LIPNICK
TECHNICAL CONSULTANT

DAVID CHALKER
TECHNICAL CONSULTANT

JERRY GOTT
TECHNICAL CONSULTANT

MIKE SOUZA
TECHNICAL CONSULTANT

AUTOMATIC TRANSMISSION SERVICE GROUP
18639 S.W. 107TH AVENUE
MIAMI, FLORIDA 33157
(305) 670-4161

FORD 5R55N

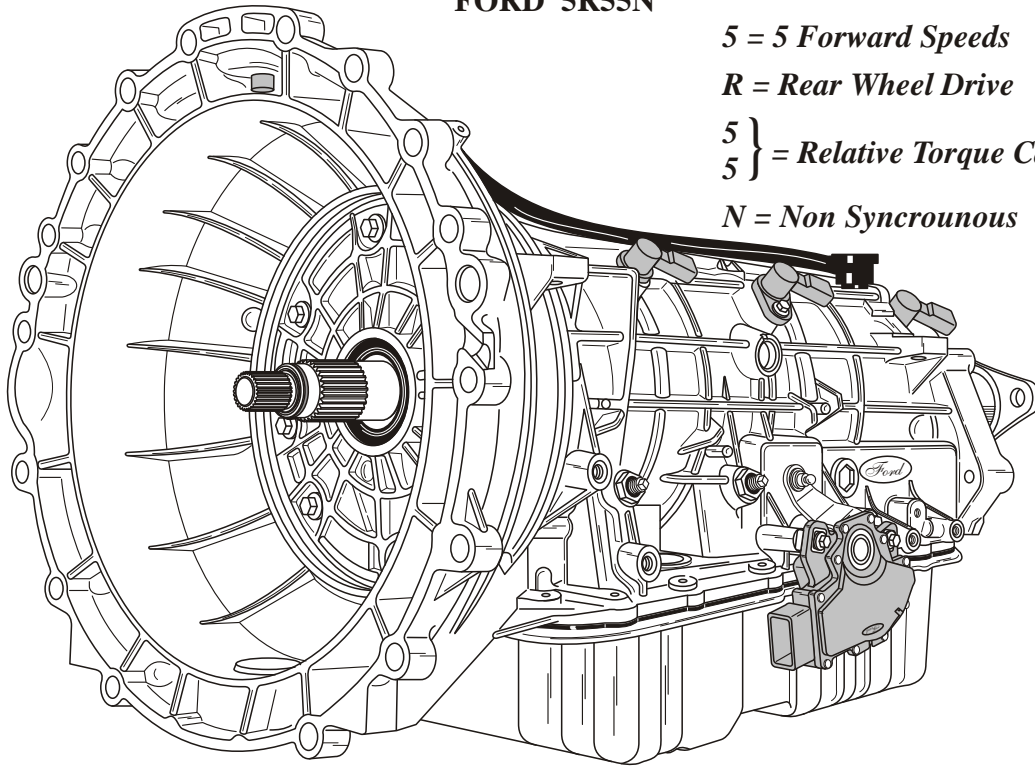

5 = 5 Forward Speeds

R = Rear Wheel Drive

$\frac{5}{5}$ } = Relative Torque Capacity

N = Non Synchronous

I.D. TAG INFORMATION FOUND ON RIGHT REAR SIDE OF TRANSMISSION

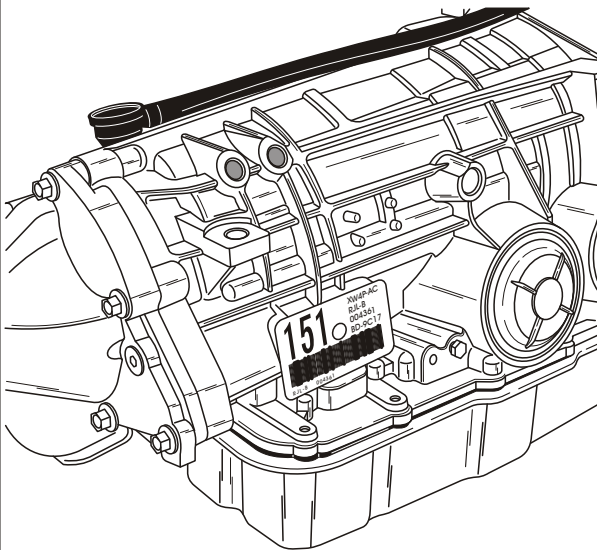

151

XW4P-AC ← 1

RJL-B ← 2

004361 ← 3

BD-9C17 ← 4

RJL-B 004361

1. Part Number, Basic = 7000 (Example XW4P-7000-AC)
2. Transmission Model Code
3. Serial Number
4. Build Date (YMDD)

Part Number	Model Code (ID Tag Color)	Vehicle Application	Engine	Axle Ratio
XR8P-AC	RJL-D (Apricot)	Jaguar X200	4.0L, V8	3.31
XR8P-BC	RJL-C (Lt. Green)	Jaguar X200	3.0L, V6	3.31
XW4P-AC	RJL-B (Yellow)	Lincoln "LS"	3.9L, V8	3.58
XW4P-BC	RJL-A (White)	Lincoln "LS"	3.0L, V6	3.58

Figure 1

FORD 5R55N COMPONENT APPLICATION CHART

RANGE	FWD CLUT	INT ¹ CLUT	DIR CLUT	COAST CLUT	O/D BAND	INT ² BAND	L/R BAND	O/D SPRAG	INT ³ SPRAG	LOW SPRAG	RATIO
Park											
Reverse			ON	ON			ON	HOLD			3.07
Neutral											
"D5"-1st Gear	ON							HOLD		HOLD	3.25
"D5"-2nd Gear	ON				ON					HOLD	2.44
"D5"-3rd Gear	ON	ON						HOLD	HOLD		1.55
"D5"-4th Gear	ON	ON	ON					HOLD			1.00
"D5"-5th Gear	ON	ON	ON		ON						0.75
"D4"-1st Gear	ON			ON				HOLD		HOLD	3.25
"D4"-2nd Gear	ON				ON					HOLD	2.44
"D4"-3rd Gear	ON	ON		ON				HOLD	HOLD		1.55
"D4"-4th Gear	ON	ON	ON	ON				HOLD			1.00
"3"-1st Gear	ON			ON				HOLD		HOLD	3.25
"3"-2nd Gear	ON				ON					HOLD	2.44
"3"-3rd Gear	ON	ON		ON		ON		HOLD	HOLD		1.55
"2"-2nd Hold *	ON				ON		ON			HOLD	2.44
"1"-1st Hold	ON			ON			ON	HOLD		HOLD	3.25

* Manual "2" is 2nd starts and hold.

** Manual "1" provides 1st gear operation only.

1 - Ford named the new clutch Intermediate Clutch, actually active in 3rd gear.

2 - Intermediate Band is now ON only in Manual 3rd gear.

3 - Ford named the new sprag Intermediate Sprag, actually active in 3rd gear.

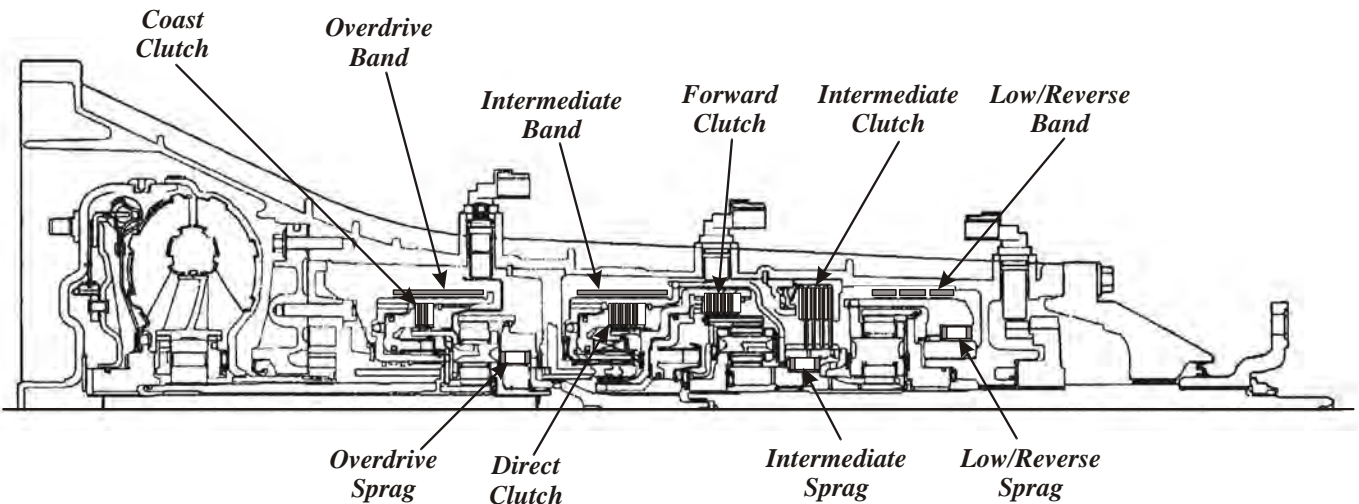

Copyright © 2001 ATSG

Figure 2



Technical Service Information

FORD 5R55N SOLENOID APPLY CHART

Range And Gear Commanded	Shift Sol. "A"	Shift Sol. "B"	Shift Sol. "C"	Shift Sol. "D"	Pres Cont Sol. "A"	Pres Cont Sol. "B"	Pres Cont Sol. "C"	TCC Solenoid
Park/Neutral	ON			ON	"L"	"C"	"L"	
Reverse	ON			ON	"L"	"H"	"H"	
D5 - 1st Gear	ON			ON	"C"	"L"	"L"	
D5 - 2nd Gear	ON		ON	ON	"L"	"C"	"L"	
D5 - 3rd Gear	ON	ON		ON	"C"	"L"	"L"	**
D5 - 4th Gear				ON	"C"	"L"	"H"	**
D5 - 5th Gear			ON	ON	"C"	"C"	"H"	**
D4 - 1st Gear	ON			ON	"C"	"L"	"L"	
D4 - 2nd Gear	ON		ON	ON	"L"	"C"	"L"	
D4 - 3rd Gear	ON	ON		ON	"C"	"L"	"L"	**
D4 - 4th Gear					"C"	"C"	"H"	**
"3" - 3rd Gear	ON	ON			"C"	"C"	"L"	
"2" - 2nd Gear (Hold)	ON		ON		"C"	"C"	"L"	
"1" - 1st Gear (Hold)	ON				"C"	"C"	"L"	

"L" = Low Line Pressure

"C" = Control Line Pressure

"H" = High Line Pressure

** = TCC On is dependent on vehicle speed and throttle position

CASE CONNECTOR PIN IDENTIFICATION AND RESISTANCE CHARTS

Solenoid Resistance Chart		
Component	Connector Terminals	Resistance In Ohms
Shift Solenoid "A"	3 And 16	16-45
Shift Solenoid "B"	3 And 15	16-45
Shift Solenoid "C"	3 And 6	16-45
Shift Solenoid "D"	3 And 5	16-45
Pressure Control Solenoid "A"	3 And 1	3.3-7.5
Pressure Control Solenoid "B"	3 And 4	3.3-7.5
Pressure Control Solenoid "C"	3 And 11	3.3-7.5
TCC Solenoid	3 And 14	9-16
Reverse Pressure Switch	12 And 13	Open/Closed
TOT Sensor	2 And 12	See Chart

TOT Sensor Resistance Chart
0°F-31°F = 284k - 100k Ohms
32°F-68°F = 100k - 37k Ohms
69°F-104°F = 37k - 16k Ohms
105°F-158°F = 16k - 5k Ohms
159°F-194°F = 5k - 2.7k Ohms
195°F-230°F = 2.7k - 1.5k Ohms
231°F-266°F = 1.5k - 0.8k Ohms
267°F-302°F = 0.8k - 0.54k Ohms

Refer To Figure 4 For Case Connector Pin Identification

Copyright © 2001 ATSG

Figure 3

CASE CONNECTOR PIN IDENTIFICATION

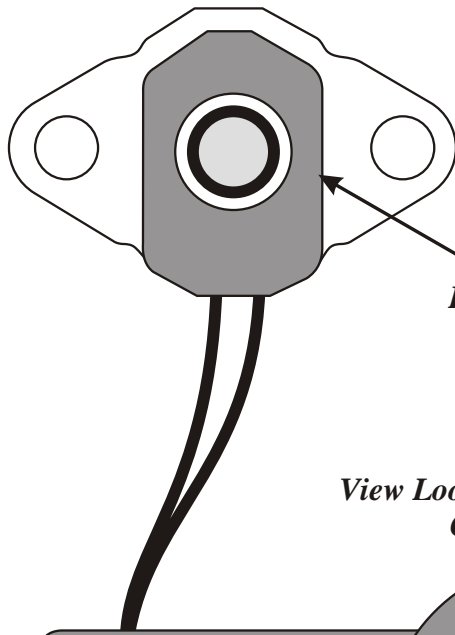

*No Pressure Present = Open
Pressure Present = Closed*

REVERSE PRESSURE SWITCH

View Looking Into Transmission Case Connector

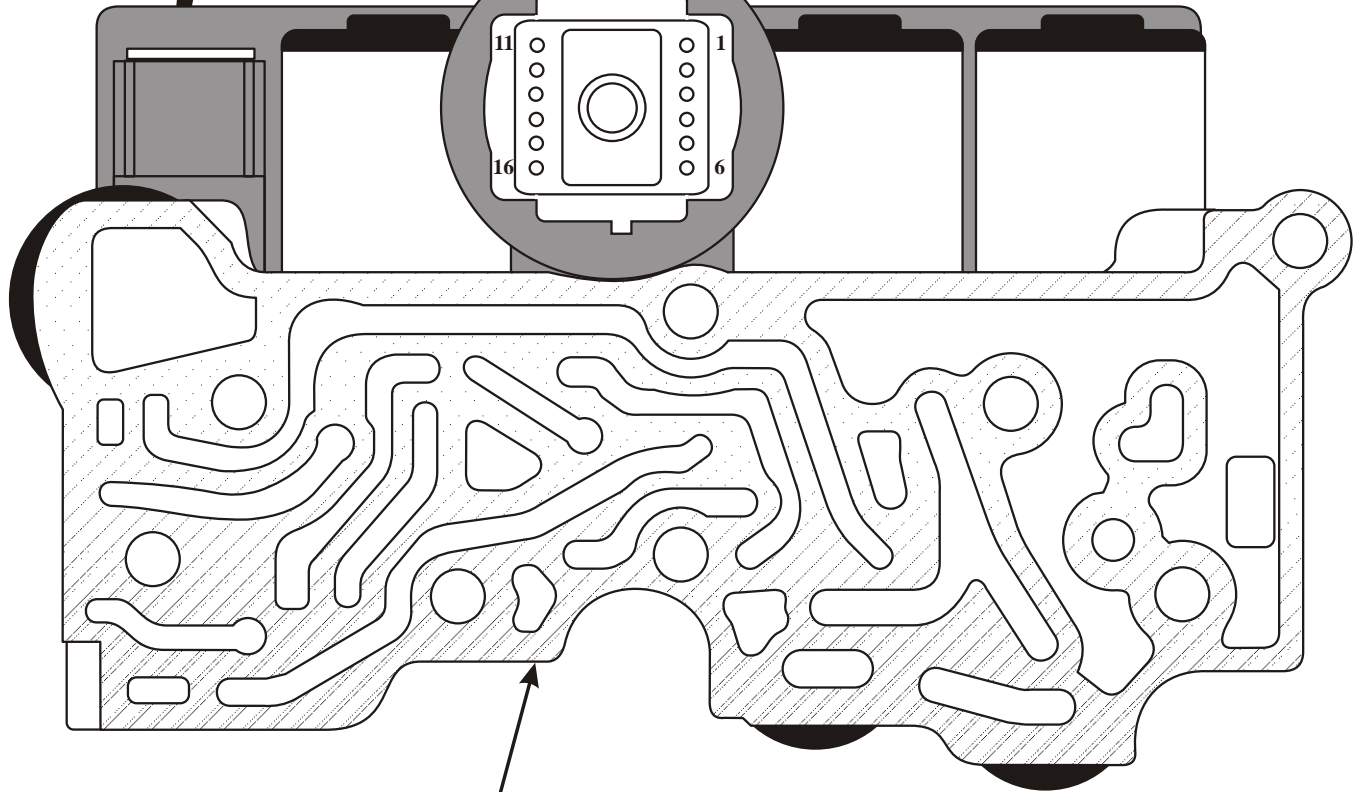
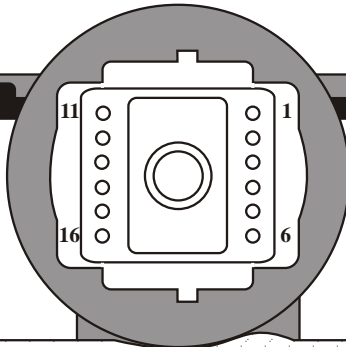

SOLENOID PACK ASSEMBLY

Figure 4



Technical Service Information

GENERAL DESCRIPTION AND OPERATION

The 5R55N is a fully automatic rear wheel drive transmission. It provides Park, Reverse, Neutral, and five forward speeds with 5th gear being overdrive

Internally it looks *similar* to the previous 5R55E transmission, but there are very few minor components that are actually the same, so be very cautious during the rebuild process. The major components used in this unit are as follows:

- **4 Multi-Plate Clutch Packs**
 - Coast Clutch*
 - Direct Clutch (Single Sided)*
 - Forward Clutch*
 - Intermediate Clutch (New)(Single Sided)*
- **3 One-Way Clutches**
 - Overdrive Sprag Clutch*
 - Intermediate Sprag Clutch (New)*
 - Low Sprag Clutch*
- **3 Brake Bands**
 - Overdrive Band*
 - Intermediate Band*
 - Low/Reverse Band*
- **3 Compound Planetary Gear Sets**
 - Overdrive Planetary Set*
 - Forward Planetary Set*
 - Rear Planetary Set*

The shift pattern is controlled electronically with four (On-Off) solenoids that receive a ground signal from the PCM (Powertrain Control Module). The PCM will vary shift points, as it is constantly interpreting numerous electronic signals from various operational sensors located on the vehicle and inside the transmission.

Line pressure and shift feel are also controlled electronically with three Pressure Control solenoids, referred to as PCA, PCB, and PCC. The PCM varies the current to the pressure control solenoids and Ford refers to them as Variable Force Solenoids.

The PCM also controls application of the converter clutch and apply feel electronically, with a TCC solenoid, which is also Variable Force style.

All solenoids are incorporated in the "Solenoid Body", located on the valve body, and are not serviced separately. You must purchase the entire solenoid body assembly, if necessary.

There is also a Transmission Fluid Temperature (TFT) sensor incorporated in the solenoid body assembly that informs the PCM of the fluid temperature. These units currently have a *dedicated "Air to Oil"* cooler for the transmission.

Also incorporated in the solenoid body assembly is a Reverse Pressure Switch that informs the PCM when pressure is present in the reverse circuit. When pressure is not present, the switch is open, and when pressure is present the switch is closed.

The PCM also receives input signals from various sensors and switches, located externally, that affect proper transmission operation. The following will provide a brief description of each of the sensors and actuators used to control transmission operation.

AIR CONDITIONING CLUTCH

This switch is located on the suction accum/drier and when the A/C is engaged, operating pressures are adjusted to compensate for the additional engine load.

BRAKE PEDAL POSITION (BPP) SWITCH

This switch is located on the brake pedal and tells the PCM when the brakes are applied. The TCC is disengaged when the brakes are applied. The BPP switch closes when the brakes are applied and open when they are released.

ENGINE COOLANT TEMPERATURE (ECT) SENSOR

This sensor detects temperature of engine coolant and supplies the information to the PCM. The PCM uses this information to control Torque Converter Clutch (TCC) operation.

ELECTRONIC IGNITION (EI) SYSTEM

The ignition control module generates a Profile Ignition Pickup (PIP) signal (engine rpm) and sends it to the PCM. The PCM uses PIP signal in the transmission strategy for WOT shift control, TCC control and operating pressures.

INTAKE AIR TEMPERATURE (IAT) SENSOR

The Intake Air Temperature (IAT) sensor, located in the air cleaner outlet tube, is also used in the transmission strategy to determine control pressures.

Continued On Next Page

Copyright © 2001 ATSG



Technical Service Information

ELECTRONIC COMPONENTS

MASS AIR FLOW (MAF) SENSOR

The Mass Air Flow (MAF) sensor, located in the air cleaner inlet tube, measures the amount of air flowing into the engine and sends this information (engine load) to the PCM. For transmission strategies the MAF is used to regulate electronic pressure control, shift timing and torque converter clutch scheduling.

TRANSMISSION CONTROL SWITCH (TCS)

The Transmission Control Switch (TCS), located within the manual range selector assembly (Base Shifter Only), and the PCM uses this signal to disable 5th gear operation and activates the coast clutch. At the same time the PCM changes the PRNDL indicator on the instrument panel to display "D4". When the driver moves the range selector back to the "D5" position, 5th gear operation is resumed, coast clutch is released and the instrument panel indicator will display "D5".

THROTTLE POSITION SENSOR (TPS)

The Throttle Position Sensor is a potentiometer located on the throttle body and is used to detect throttle plate position and send this information to the PCM. The PCM uses this information for shift scheduling, pressure control and TCC control.

DIGITAL TRANSMISSION RANGE (TR) SENSOR

The Digital Transmission Range (TR) sensor is located on the outside of the transmission at the manual shift lever. The digital TR sensor completes the start circuit in Park and Neutral, and the back-up lamp circuit in Reverse. The digital TR sensor also opens or closes a set of four switches that are monitored by the PCM to determine the position of the manual lever (P, R, N, D5, 3, 2, 1).

TURBINE SHAFT SPEED (TSS) SENSOR

The Turbine Shaft Speed (TSS) sensor is mounted externally on the transmission case, and triggered by the overdrive carrier. The PCM uses TSS to help determine appropriate operating pressures and TCC operation.

INTERMEDIATE SHAFT SPEED (ISS) SENSOR

The Intermediate Shaft Speed (ISS) sensor is mounted externally on the case, and triggered by the sun gear shell. The PCM uses ISS to aid in determining appropriate pressure requirements.

OUTPUT SHAFT SPEED (OSS) SENSOR

The Output Shaft Speed (OSS) sensor is mounted externally on the transmission case, and triggered by a speed rotor on the parking gear on the output shaft. The PCM uses OSS to determine appropriate shift speed scheduling, operating pressures and TCC operation.

PRESSURE CONTROL SOLENOIDS (PCA, PCB, PCC)

The Pressure Control solenoids PCA, PCB and PCC are located in the solenoid body assembly and are a variable-force style (VFS) solenoid. The VFS type solenoid is an electro-hydraulic actuator that combines a solenoid and a regulating valve. The PCM varies the current to all three pressure control solenoids.

The line pressure tap is used to verify output pressure from "PCA" or "PCB" by turning off either one, while verifying the output from the other solenoid. The second pressure tap is used to verify the output pressure from "PCC" solenoid.

SHIFT SOLENOIDS (SSA, SSB, SSC, SSD)

The four On-Off Shift Solenoids are three-way, normally open style solenoids, and also located in the solenoid body assembly. The four shift solenoids, (SSA, SSB, SSC, SSD), provide gear selection of 1st through 5th and reverse gears by directing control pressures to the appropriate element. Coast braking and manual gear selections are also controlled by the shift solenoids.

TORQUE CONVERTER CLUTCH (TCC) SOLENOID

The Torque Converter Clutch (TCC) solenoid is a pulse width modulating type of solenoid and is used to control the apply and release of the TCC. Like the others, it is located in the solenoid body assembly.

TRANSMISSION FLUID TEMPERATURE (TFT) SENSOR

The Transmission Fluid Temperature (TFT) sensor is a thermister type sensor that varies a reference signal to the PCM. The PCM uses this information to determine fluid temperature. The shift schedule is compensated when fluid is cold. The PCM also inhibits TCC operation, and compensates pressure control solenoids when fluid is cold. The PCM uses TFT signal to help determine shift scheduling, TCC operation and pressure control requirements.

Copyright © 2001 ATSG



Technical Service Information

REVERSE PRESSURE (RP) SWITCH

The Reverse Pressure (RP) switch, wired into the solenoid body and bolted on the main valve body, is a simple open or closed switch used to determine the presence of pressure in the reverse circuit. The PCM uses this information for appropriate pressure requirements. When pressure is not present the switch is open, and when pressure is present the switch is closed.

INSTRUMENT PANEL RANGE SELECTOR INDICATOR

The indicator is an electronic readout in the instrument cluster which will match the position of the range selector (P, R, N, D5, D4, 3, 2, 1). There is a Park Sense Switch incorporated in the shifters that prevents the PRNDL from displaying "P" until the shifter is fully in the Park position.

In the event that an error in the range selector occurs, an "E" for error will be displayed on the instrument panel.

MANUAL SHIFT SELECTOR

"P" = Park

When in the Park position, there is no power flow through the transmission and the parking pawl locks the output shaft to the case. The engine may be started and the key may be removed.

"R" = Reverse

When in the Reverse position, the vehicle may be operated in a rearward direction at a reduced gear ratio, and the back-up lamps are illuminated.

"N" = Neutral

When in the Neutral position, there is no power flow through the transmission, the output shaft is not held and is free to turn. The engine may be started and the key can not be removed.

"D5" = Overdrive

When in the D5 position, there will be automatic upshifts 1st through 5th gear, automatic downshifts 5th through 1st gear, and apply and release of the TCC depending on vehicle speed, throttle position and engine coolant temperature. This is the normal position for most forward driving and provides the maximum fuel economy during normal operation. This unit also has engine braking in 5th gear.

"D4" = Overdrive Canceled

When in the D4 position, there will be automatic upshifts 1st through 4th gear, automatic downshifts 4th through 1st gear, and apply and release of the TCC depending on vehicle speed, throttle position and engine coolant temperature. This position may be selected for towing, or driving in hilly terrain. This unit also has engine braking in 4th gear.

"3" = 3rd Gear (Base Shifter)

When in the 3 position, there will be 3rd gear starts and 3rd gear hold, no upshifts nor downshifts. The TCC may apply or release depending on vehicle speed, throttle position and engine coolant temperature. This position is best suited for engine braking in hilly terrain, or for improved traction on slippery roads.

"2" = 2nd Gear (Base Shifter)

When in the 2 position, there will be 2nd gear starts and 2nd gear hold, no upshifts nor downshift. The TCC may apply or release depending on vehicle speed, throttle position and engine coolant temperature. This position is best suited for engine braking in hilly terrain, or for improved traction on slippery roads.

"1" = 1st Gear (Base Shifter)

This position provides 1st gear operation only, and used for descending steep grades. If this position is selected at normal road speeds, the transmission will downshift to the next lower gear, and continue downshifting at safe pre-calibrated road speeds until it reaches 1st gear.

Special Note: Refer to Figure 5 for illustrations of the Basic, and Optional, Manual Range Shifters.

Copyright © 2001 ATSG

OPTIONAL MANUAL SHIFT SELECTOR

"P" = Park

When in the Park position, there is no power flow through the transmission and the parking pawl locks the output shaft to the case. The engine may be started and the key may be removed.

"R" = Reverse

When in the Reverse position, the vehicle may be operated in a rearward direction at a reduced gear ratio, and the back-up lamps are illuminated.

"N" = Neutral

When in the Neutral position, there is no power flow through the transmission, the output shaft is not held and is free to turn. The engine may be started and the key can not be removed.

"D5" And "D4"

When in these positions, gear ranges 1st through 5th gears provide exactly the same function and ratios as found in the "D5" or "D4" automatic mode positions.

SELECT SHIFT TRANSMISSION (SST) SWITCHES(+and-)

The positions indicated by a (+) or a (-) allow the driver to manually select the appropriate upshift (+) or downshift (-). The PCM uses the input signals from the SST+ and the SST- switches, along with other vehicle inputs to determine which gear should be commanded.

SELECT SHIFT OPERATION (SST) SWITCHES(+and-)

- Can only be entered from the "D5" position.
- Transmission will not upshift or downshift unless the selector lever is "Tapped" forward or rearward. One tap forward (+) will allow trans to upshift one gear range, and one tap rearward (-) will allow trans to downshift one gear range.
- A 2nd gear start is normal. A 3rd gear start up will be allowed only if selected. A shift to first gear with the vehicle at rest is *never* allowed. Upshifts are allowed at any vehicle speed.
- If the driver starts in 2nd gear and does not pass 60% throttle, the transmission will remain in 2nd gear. No automatic upshift will occur. If the driver passes 60% throttle, then a 2-1 automatic kickdown will occur, scheduled by the PCM as used in "D5". Once this has occurred, 1st gear will hold until 2nd gear is selected by the driver tapping the shift lever. No automatic upshift is possible under these conditions. Once a kickdown has occurred, manual shifting in and out of 1st gear is allowed until the next time the vehicle stops.
- When downshifting at normal road speeds, the transmission will only allow a downshift into the next lower gear.

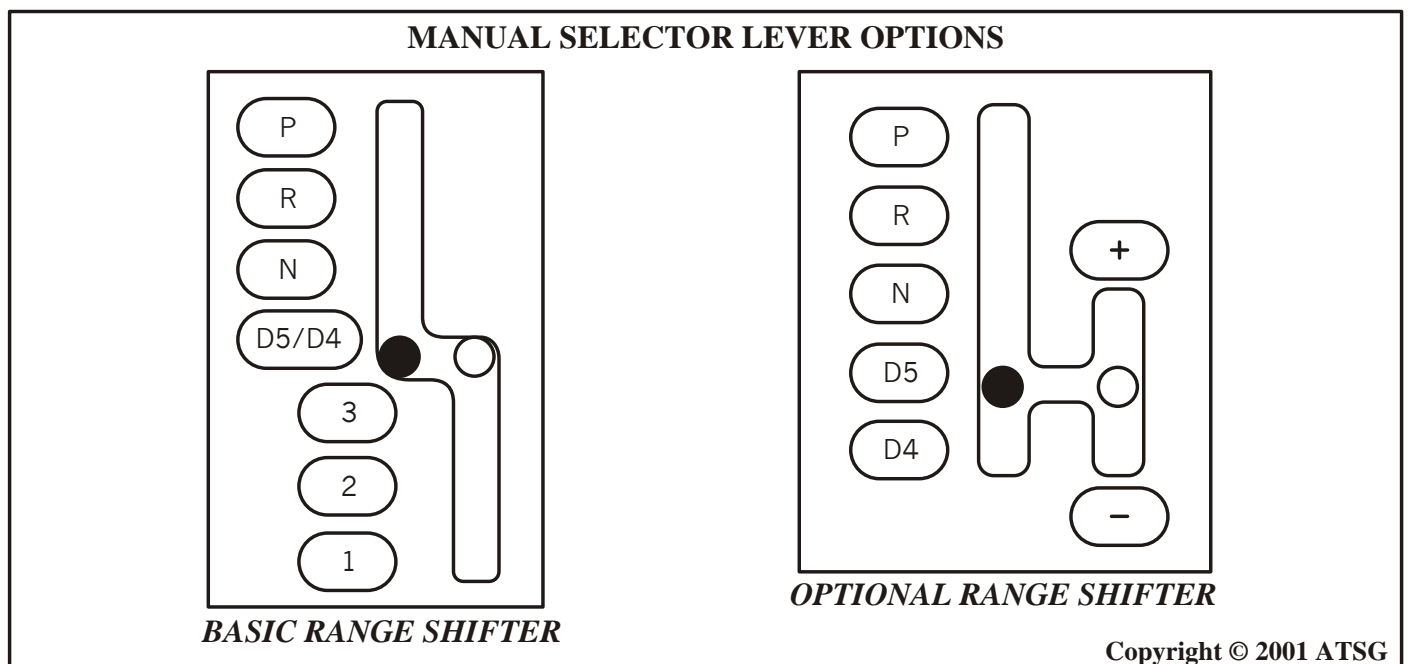

Figure 5

- If the shift lever is tapped for a downshift (-) more than once in rapid succession, the transmission will downshift only into the next lower gear. Then when the vehicle reaches a speed below a pre-calibrated entry speed, the transmission will allow a downshift into the next lower gear, if once again selected by the driver. This is to prevent engine and transmission damage by keeping the engine and transmission within allowable rpm ranges.
- The electronic indicator on the instrument cluster will display the gear selected by the driver.

COMPONENT LOCATER CHART	
NO.	
1	<i>Auxilliary Junction Box (AJB) Underhood</i>
2	<i>ABS Control Module</i>
3	<i>Powertrain Control Module (PCM)</i>
4	<i>Electronic Auto. Temp. Control Module</i>
5	<i>Front Electronic Module (FEM)</i>
6	<i>Auxilliary Junction Box (AJB) Interior</i>
7	<i>Instrument Cluster</i>
8	<i>Restraints Control Module (RCM)</i>
9	<i>Central Junction Box (CJB)</i>
10	<i>Driver Seat Module</i>
11	<i>Heated Seat Module, Driver Side Front</i>
12	<i>Heated Seat Module, Pass. Side Front</i>
13	<i>Driver Door Module (DDM)</i>
14	<i>Rear Electronic Module (REM)</i>
15	<i>Battery Junction Box (BJB)</i>
16	<i>Cellular Phone Module</i>
17	<i>Remote Emergency Satellite Cellular Unit</i>
18	<i>Battery</i>

Refer To Figure 6 Below

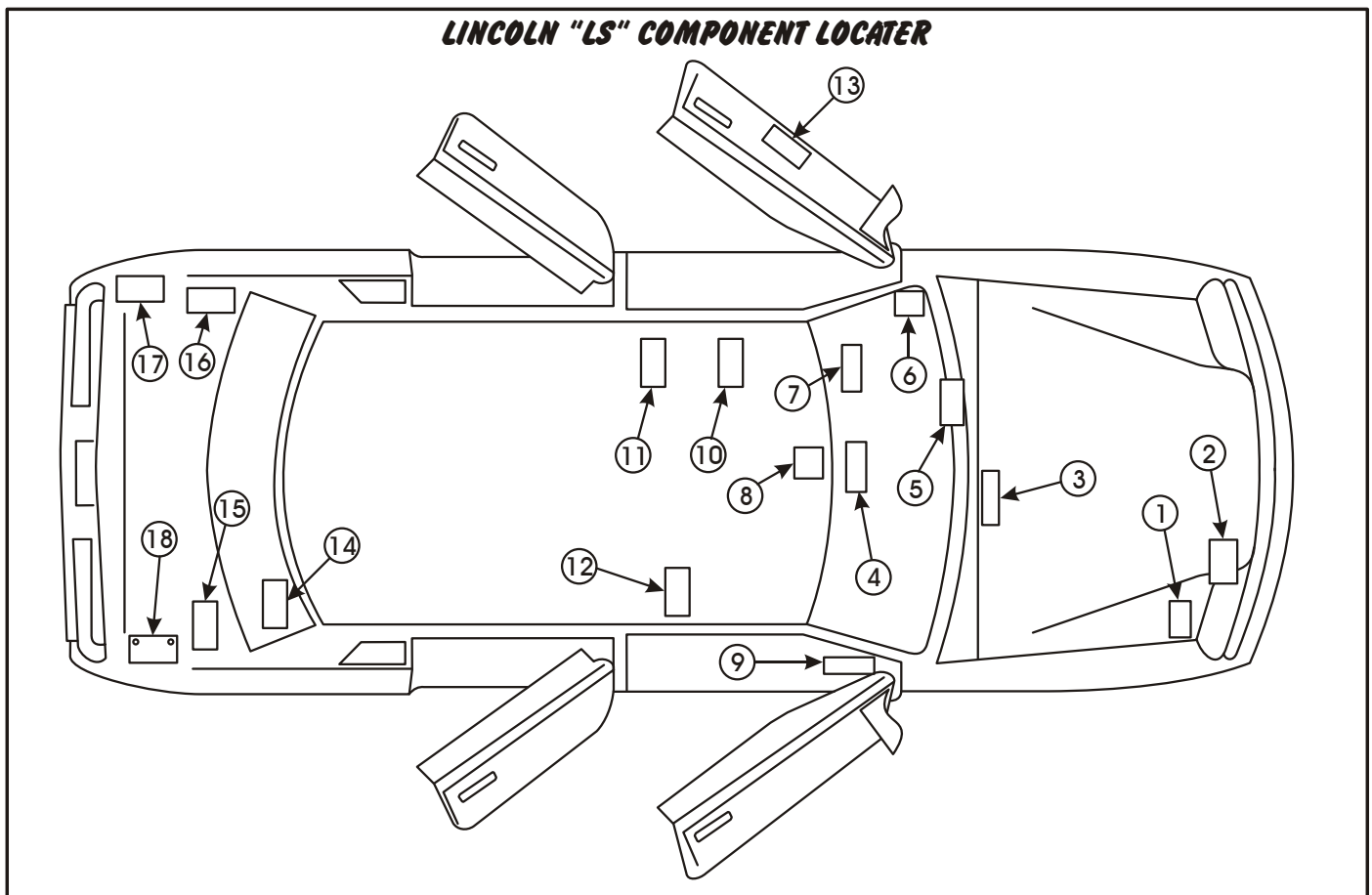

Figure 6

AUXILLIARY JUNCTION BOX (AJB), UNDERHOOD

<i>AUXILLIARY JUNCTION BOX (UNDERHOOD)</i>	
<i>Transmission Related Fuses Only</i>	
<i>FUSE</i>	<i>APPLICATION</i>
<i>F101</i>	<i>A/C Clutch Relay (10A)</i>
<i>F105</i>	<i>MAF And Injectors (20A)</i>
<i>F106</i>	<i>Trans Case Connector, Term 3 (15A)</i>
<i>F111</i>	<i>A/C Clutch Relay (15A)</i>
<i>F114</i>	<i>ABS Control Module, Term 25 (30A)</i>
<i>F118</i>	<i>PCM Power Relay (40A)</i>
<i>F121</i>	<i>Starter Relay (25A)</i>
<i>F122</i>	<i>ABS Control Module, Term 9 (30A)</i>

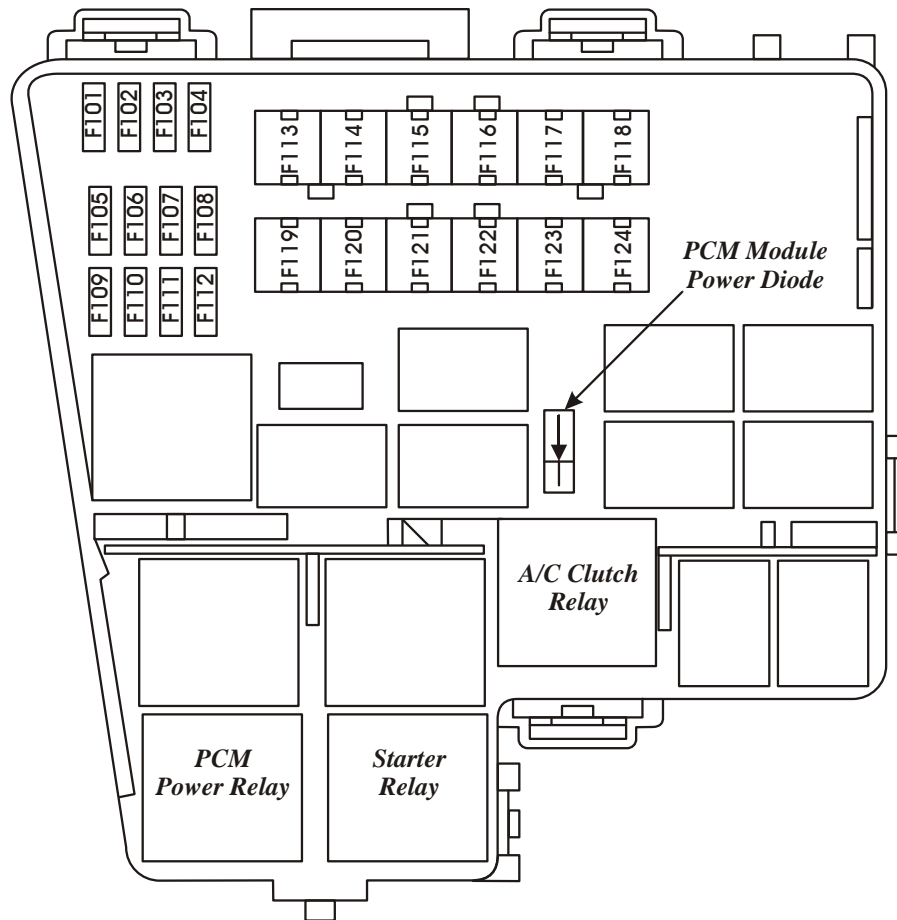
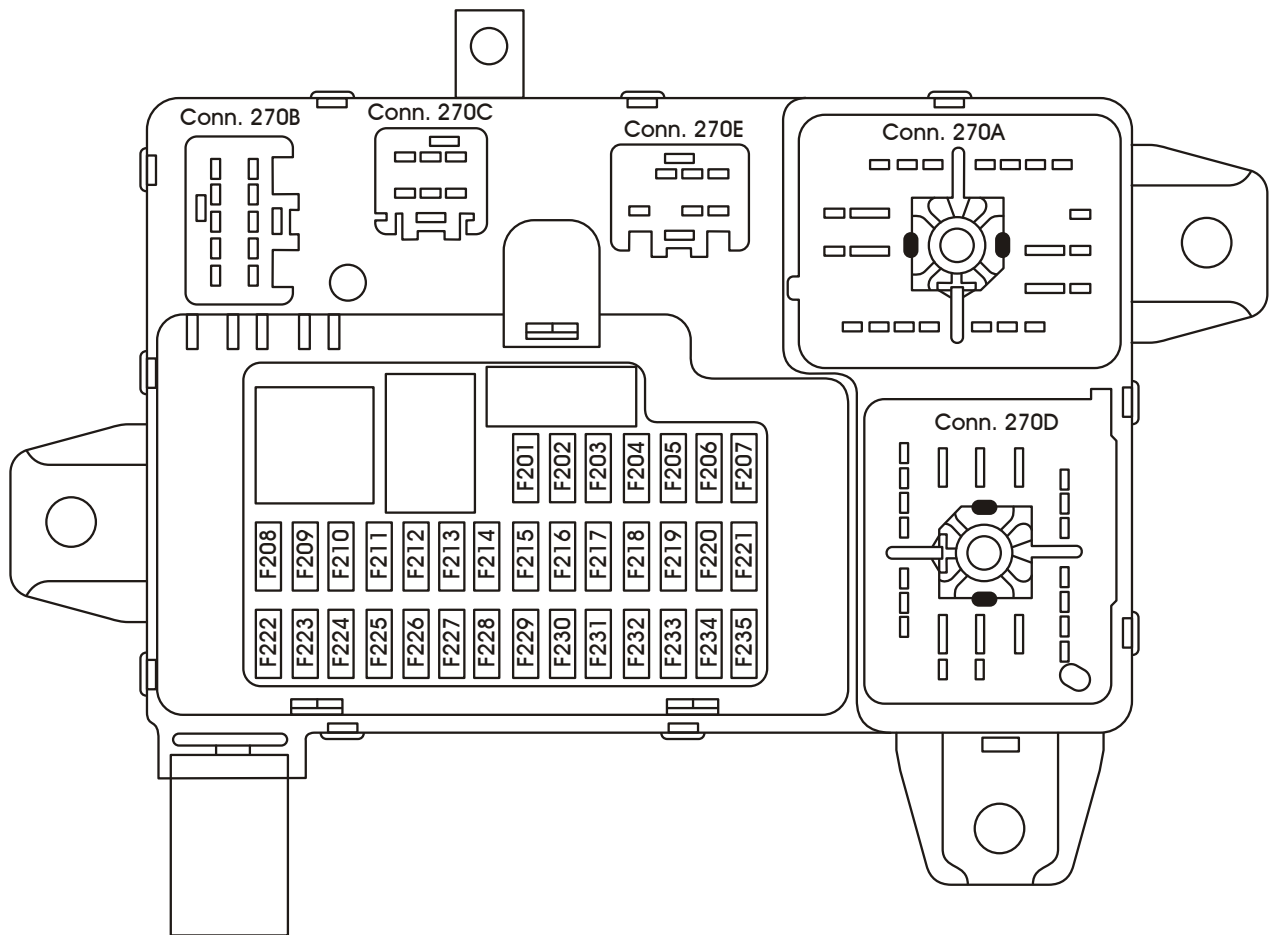

Figure 7

CENTRAL JUNCTION BOX (CJB) (LOCATED UNDER DASH PANEL RH SIDE)

<i>CENTRAL JUNCTION BOX</i>	
<i>Transmission Related Fuses Only</i>	
<i>FUSE</i>	<i>APPLICATION</i>
<i>F201</i>	<i>Digital Transmission Range Sensor, Term 10 (5A)</i>
<i>F204</i>	<i>PCM Power Diode (5A)</i>
<i>F204</i>	<i>PCM Power Relay, Term 86 (5A)</i>
<i>F204</i>	<i>Trans Shift Selector, Term 3 (5A)</i>
<i>F205</i>	<i>Trans Shift Selector, Term 7 (5A)</i>
<i>F205</i>	<i>TCS Illumination Lamp (5A)</i>
<i>F206</i>	<i>Data Link Connector, Term 16 (10A)</i>
<i>F207</i>	<i>Powertrain Control Module, Term 44 (5A)</i>



Copyright © 2001 ATSG

Figure 8

VARIOUS CONNECTOR AND PIN IDENTIFICATION

(All Connector Views Are Looking Into Connectors With Connector Removed)

**PCM Connector
Number 175A**

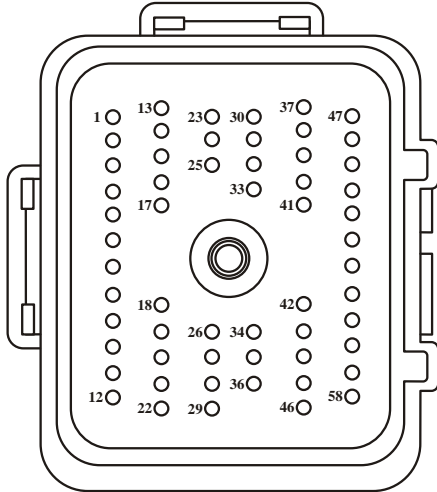

**PCM Connector
Number 175B**

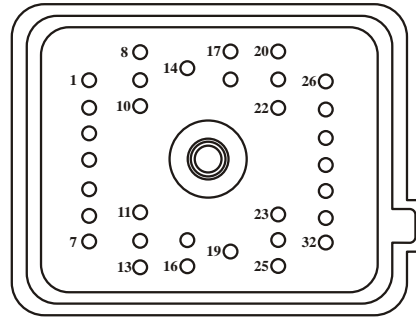

**PCM Connector
Number 175C**

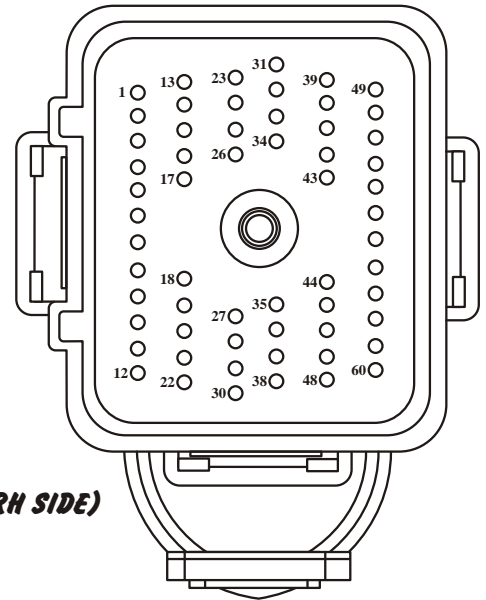

(PCM LOCATION, ENGINE COMPARTMENT - RH SIDE)

**Data Link
Connector**

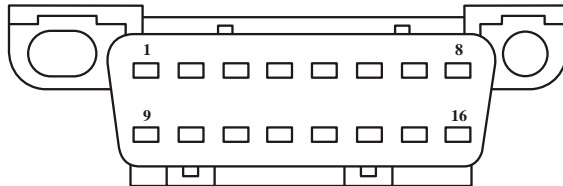

**Transmission
Case Connector**

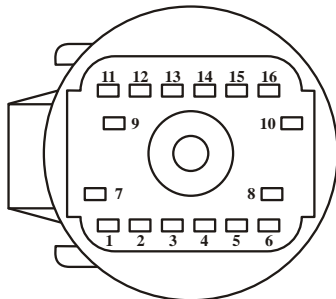

**Digital Transmission
Range Sensor Connector**

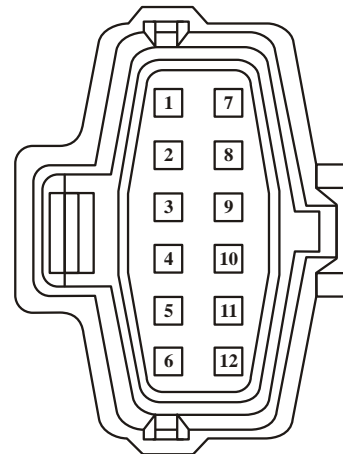
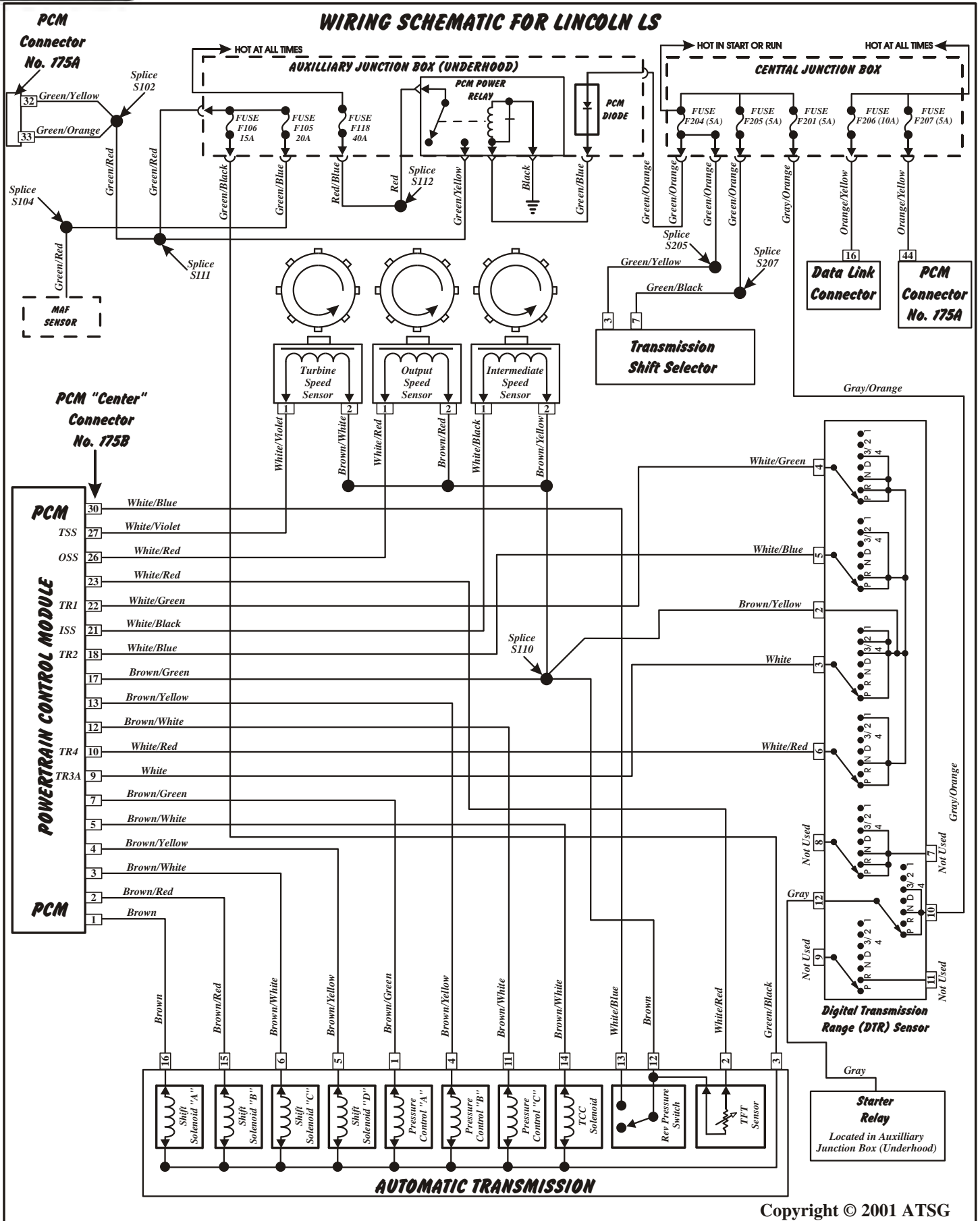

Figure 9



Copyright © 2001 ATSG

Figure 10

RESISTANCE CHART FOR TRANSMISSION COMPONENTS

Auxiliary Junction Box (Underhood)

Remove 15 Amp Fuse F106

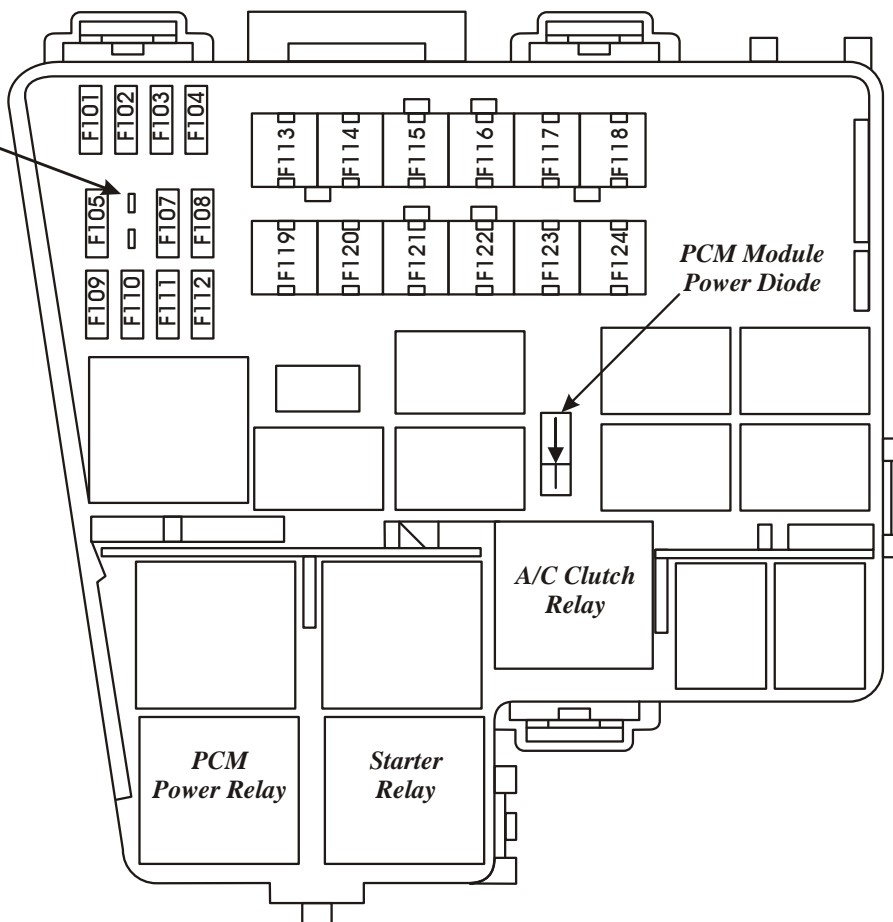

Remove PCM Connector (Center) Number 175B

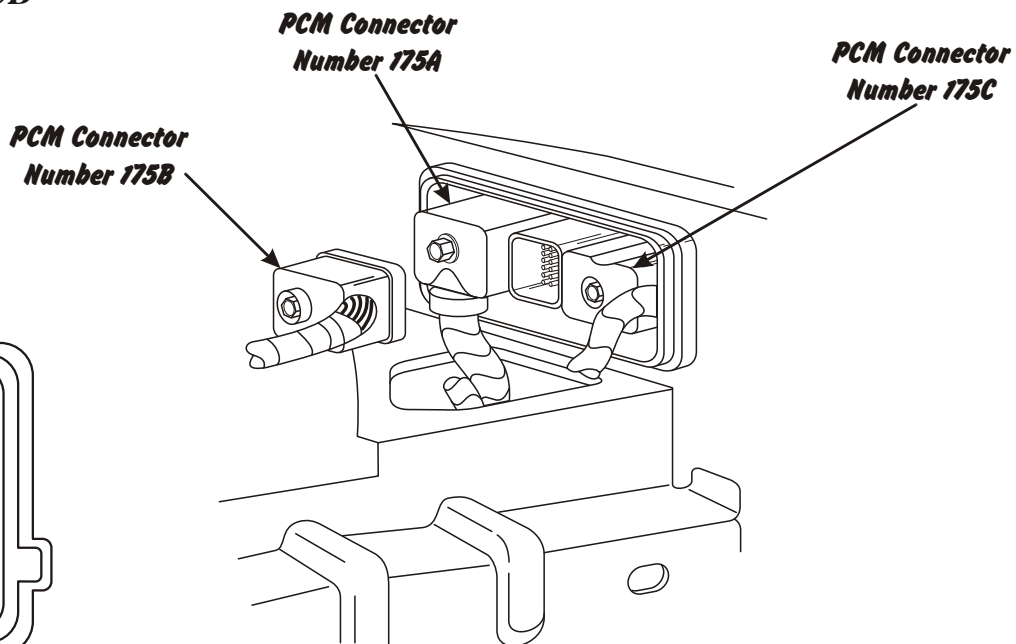

PCM Connector Number 175B (Face View)

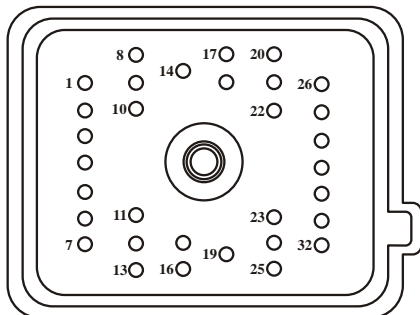

Figure 11

RESISTANCE CHART FOR TRANSMISSION COMPONENTS

COMPONENT RESISTANCE CHART THROUGH PCM CONNECTOR		
Component	Pin Numbers	Resistance
Shift Solenoid "A"	175B, Term 1 and Fuse 106	16-45 Ohms
Shift Solenoid "B"	175B, Term 2 and Fuse 106	16-45 Ohms
Shift Solenoid "C"	175B, Term 3 and Fuse 106	16-45 Ohms
Shift Solenoid "D"	175B, Term 4 and Fuse 106	16-45 Ohms
PC Solenoid "A"	175B, Term 7 and Fuse 106	3.3-7.5 Ohms
PC Solenoid "B"	175B, Term 13 and Fuse 106	3.3-7.5 Ohms
PC Solenoid "C"	175B, Term 12 and Fuse 106	3.3-7.5 Ohms
TCC Solenoid	175B, Term 5 and Fuse 106	9-16 Ohms
TFT Sensor	175B, Term 17 and Term 23	See Chart
Rev Pres Switch	175B, Term 17 and Term 30	Open
Turbine Speed Sensor	175B, Term 17 and Term 27	325-485 Ohms @ 70°F
Intermediate Speed Sensor	175B, Term 17 and Term 21	325-485 Ohms @ 70°F
Output Speed Sensor	175B, Term 17 and Term 26	325-485 Ohms @ 70°F

CASE CONNECTOR PIN IDENTIFICATION AND RESISTANCE CHARTS

Solenoid Resistance Chart		
Component	Connector Terminals	Resistance In Ohms
Shift Solenoid "A"	3 And 16	16-45
Shift Solenoid "B"	3 And 15	16-45
Shift Solenoid "C"	3 And 6	16-45
Shift Solenoid "D"	3 And 5	16-45
Pressure Control Solenoid "A"	3 And 1	3.3-7.5
Pressure Control Solenoid "B"	3 And 4	3.3-7.5
Pressure Control Solenoid "C"	3 And 11	3.3-7.5
TCC Solenoid	3 And 14	9-16
Reverse Pressure Switch	12 And 13	Open/Closed
TOT Sensor	2 And 12	See Chart

TFT Sensor Resistance Chart
0°F-31°F = 284k - 100k Ohms
32°F-68°F = 100k - 37k Ohms
69°F-104°F = 37k - 16k Ohms
105°F-158°F = 16k - 5k Ohms
159°F-194°F = 5k - 2.7k Ohms
195°F-230°F = 2.7k - 1.5k Ohms
231°F-266°F = 1.5k - 0.8k Ohms
267°F-302°F = 0.8k - 0.54k Ohms

Transmission Case Connector

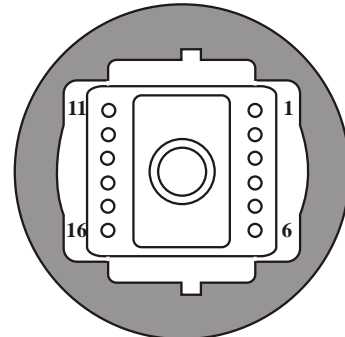

Copyright © 2001 ATSG

Figure 12

DIGITAL TRANSMISSION RANGE (DTR) SENSOR DIAGNOSIS

Snap-On
Scanner Data

Snap-On
Scanner Data

SELECTOR POSITION	PID:TR	PID:TR_D				PID:TR_V
		TR4	TR3A	TR2	TR1	TR3A (175B pin 9 to sigrtn)
PARK	P/N	0	0	0	0	0.0 Volts
REVERSE	REV	1	1	0	0	1.3 to 1.8 Volts
NEUTRAL	NTRL	0	1	1	0	1.3 to 1.8 Volts
OVERDRIVE	OD*	1	1	1	1	1.3 to 1.8 Volts
MANUAL 2	MAN 2**	1	0	0	1	0.0 Volts
MANUAL 1	MAN 1	0	0	1	1	0.0 Volts

* Will read "Drive" if OD is canceled.
** MAN 2 = Drive for applications without OD cancel feature.

1. TR_V is the voltage at PCM connector 175B, pin 9 (TR3A Circuit) to Signal Return.
2. "In-Between" reading may be caused by shift cable or DTR sensor misalignment or a DTR circuit failure of TR1, TR2, TR3A, TR4.
3. TR_D: 1 = Open DTR Switch
0 = Closed DTR Switch

4. Breakout Box readings are taken from PCM signal pins for TR1, TR2, TR3A, TR4 to Signal Return.
 Voltages for TR1, TR2, TR4: 0 = 0.0 Volts (Shorted to Ground)
 1 = 9.0 to 14.0 Volts (Open Circuit)
 Voltages for TR3A: 0 = 0.0 Volts (Circuit Shorted to Ground)
 1 = 1.3 to 5.0 Volts (Open Circuit)
 1.8 to 5.0 Volts is an invalid reading and is usually an open in wires or bad resistor in DTR sensor.

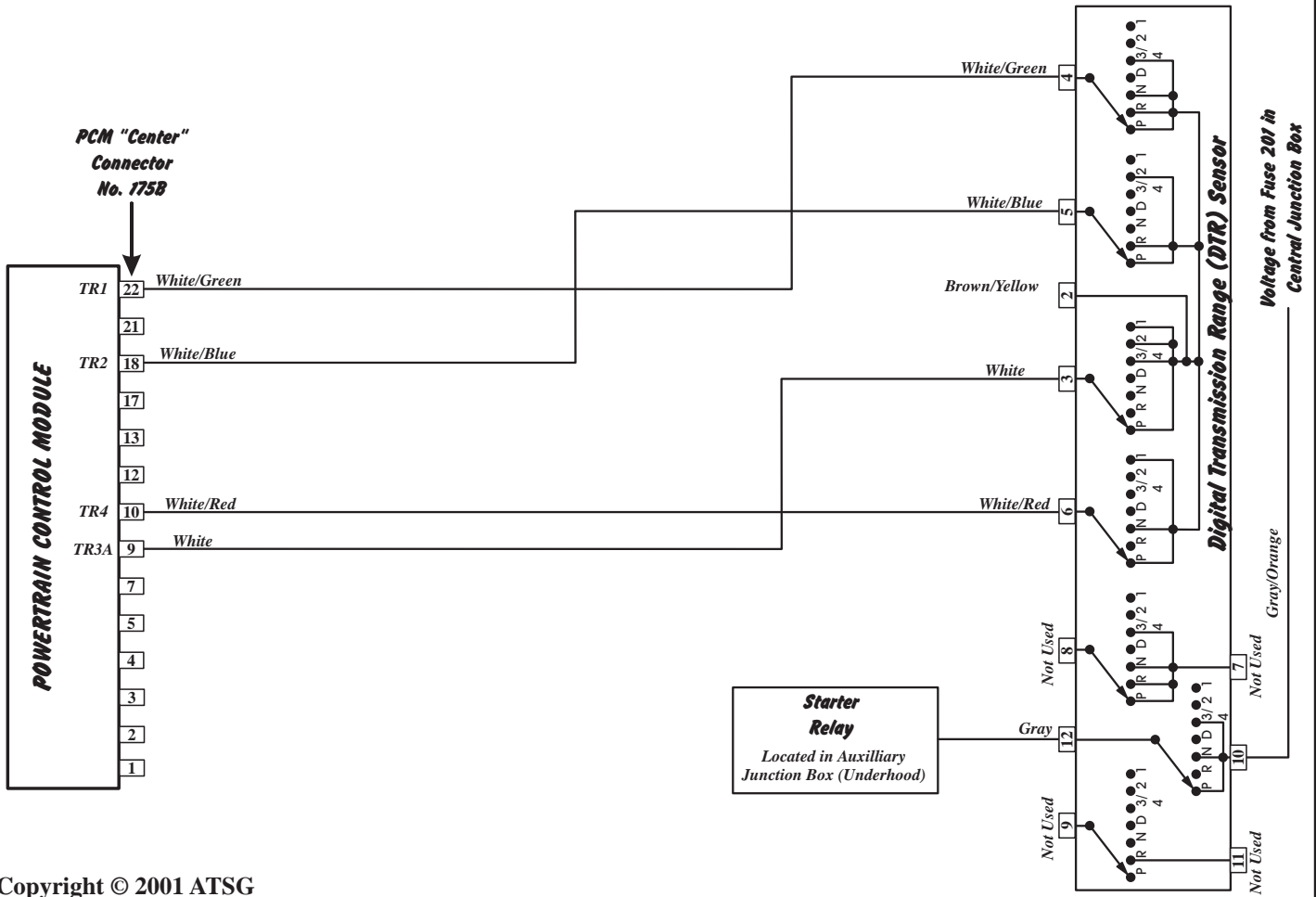

Copyright © 2001 ATSG

Figure 13



Technical Service Information

DIAGNOSTIC TROUBLE CODE (DTC) CHART AND DESCRIPTIONS	
DTC	DESCRIPTION
P0102	Mass Air Flow (MAF) sensor system concerns
P0103	Mass Air Flow (MAF) sensor system concerns
P0112	Intake Air Temperature (IAT) sensor indicates 254°F (Grounded Circuit)
P0113	Intake Air Temperature (IAT) sensor indicates -40°F (Open Circuit)
P0114	Intake Air Temperature (IAT) sensor out of "On-Board Diagnostic" range
P0116	Engine Coolant Temperature (ECT) sensor out of "On-Board Diagnostic" range
P0117	Engine Coolant Temperature (ECT) sensor indicates 254°F (Grounded Circuit)
P0118	Engine Coolant Temperature (ECT) sensor indicates -40°F (Open Circuit)
P0121	Throttle Position (TP) sensor system intermittent
P0122	Throttle Position (TP) sensor signal less than self test minimum
P0123	Throttle Position (TP) sensor signal more than self test maximum
P0300	Electronic Ignition (EI) multiple cylinder miss-fire or defective crank sensor
P0308	Electronic Ignition (EI) misfire cylinder 8
P0320	Electronic Ignition (EI) two successive erratic PIP pulses have occurred
P0340	Electronic Ignition (EI) camshaft position sensor fault
P0500	Vehicle Speed Sensor (VSS), insufficient input from ABS through SCP link
P0503	Vehicle Speed Sensor (VSS), poor performance or noisy signal
P0705	Digital Transmission Range (DTR) sensor circuit failure
P0708	Digital Transmission Range (DTR) sensor circuit TR3A Open
P0712	Transmission Fluid Temperature (TFT) circuit grounded, 315°F indicated
P0713	Transmission Fluid Temperature (TFT) circuit open, -40°F indicated
P0715	Turbine Shaft Speed (TSS) sensor, insufficient input
P0717	Turbine Shaft Speed (TSS) intermittent sensor signal
P0718	Turbine Shaft Speed (TSS) sensor signal noisy
P0720	Output Shaft Speed (OSS) sensor, insufficient input
P0721	Output Shaft Speed (OSS) sensor signal noisy
P0722	Output Shaft Speed (OSS) intermittent sensor signal
P0731	Gear Ratio Error, 1st Gear
P0732	Gear Ratio Error, 2nd Gear
P0733	Gear Ratio Error, 3rd Gear
P0734	Gear Ratio Error, 4th Gear
P0735	Gear Ratio Error, 5th Gear
P0741	Torque Converter Clutch (TCC) slippage detected
P0743	Torque Converter Clutch (TCC) solenoid circuit failure during KOEO test

Copyright © 2001 ATSG

Figure 14



Technical Service Information

DIAGNOSTIC TROUBLE CODE (DTC) CHART AND DESCRIPTIONS	
DTC	DESCRIPTION
P0745	Pressure Control "A" (PCA) solenoid, Functional fault
P0750	Shift Solenoid "A" (SSA) circuit failure during KOEO test
P0753	Shift Solenoid "A" (SSA) circuit failure during KOEO test
P0755	Shift Solenoid "B" (SSB) circuit failure during KOEO test
P0758	Shift Solenoid "B" (SSB) circuit failure during KOEO test
P0760	Shift Solenoid "C" (SSC) circuit failure during KOEO test
P0763	Shift Solenoid "C" (SSC) circuit failure during KOEO test
P0765	Shift Solenoid "D" (SSD) circuit failure during KOEO test
P0768	Shift Solenoid "D" (SSD) circuit failure during KOEO test
P0775	Pressure Control "B" (PCB) solenoid, Functional fault
P0779	Pressure Control "B" (PCB) solenoid, intermittent short to ground
P0791	Intermediate Shaft Speed (ISS) sensor signal failure
P0794	Intermediate Shaft Speed (ISS) sensor signal intermittent
P0795	Pressure Control "C" (PCC) solenoid, Functional fault
P0796	Pressure Control "C" (PCC) solenoid, open circuit
P0797	Pressure Control "C" (PCC) solenoid Functional fault
P0799	Pressure Control "C" (PCC) solenoid, intermittent short to ground
P0814	Shift "J"-Gate, circuit input signal failed
P0815	Select Shift Transmission (SST) +/- switch circuit input failed
P0840	Reverse Pressure (RP) switch circuit input signal failed
P1100	Mass Air Flow (MAF) sensor, circuit intermittent voltage input
P1101	Mass Air Flow (MAF) sensor, signal was not 0.34-1.96 during self test
P1120	Throttle Position (TP) sensor signal went to less than .49 volts
P1121	Throttle Position (TP) sensor signal inconsistant with MAF signal
P1124	Throttle Position (TP) sensor not in proper position for KOEO test
P1125	Throttle Position (TP) sensor signal went to more than 4.60 volts
P1351	Electronic Ignition (EI) concerns
P1364	Electronic Ignition (EI) concerns
P1460	Air Conditioning (AC) clutch cycling pressure switch error
P1636	SSx ISIG communication error (Replace PCM)
P1700	Internal transmission component failure
P1702	Digital Transmission Range (DTR) sensor signal intermittent
P1703	Brake Pedal Position (BPP) not cycled during KOER test, or switch circuit failed
P1704	Digital Transmission Range (DTR) sensor, not in P or N during KOEO/KOER

Copyright © 2001 ATSG

Figure 15

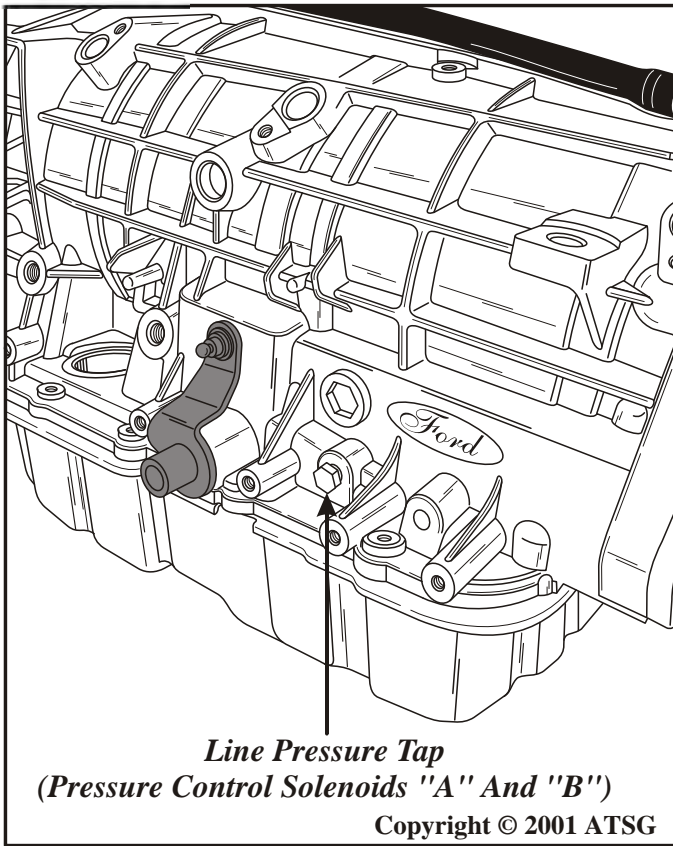

Figure 17

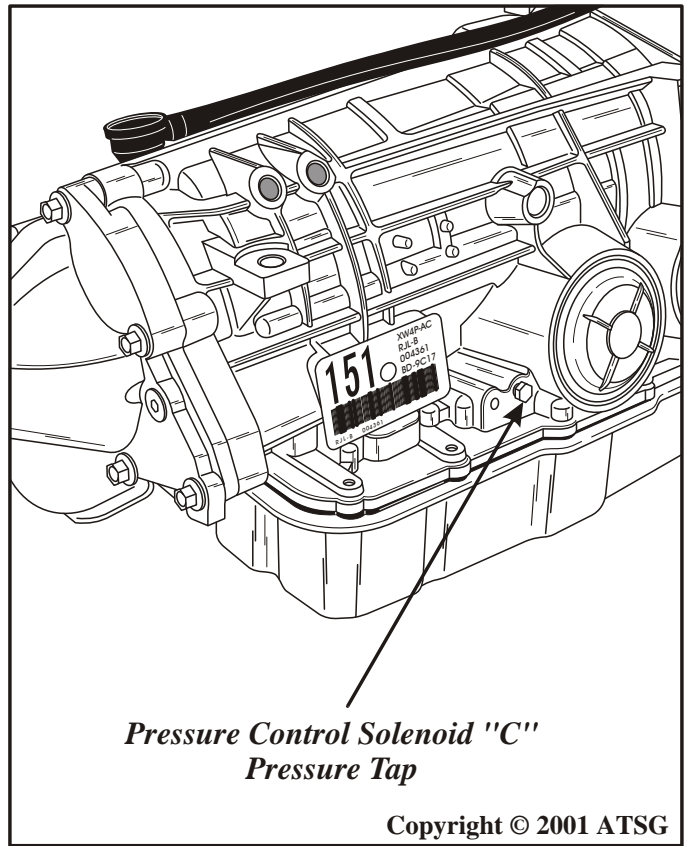

Figure 18

LINE PRESSURE TEST

1. There are 3 Pressure Control solenoids located in the solenoid body, PC "A", PC "B", PC "C", used to control all application pressures.
2. Start engine and check line pressures using the chart provided below to determine if the line pressure is within specifications.

Special Note: The line pressure tap in Figure 17, is used to verify output pressure from PC "A" or from PC "B", by turning either one OFF while verifying pressure from the other solenoid.

The 2nd pressure tap in Figure 18, is used to verify pressure readings from PC "C" solenoid. Use the chart below for proper specifications.

Vehicle/Engine	Range	Idle Line Pres.	WOT Line Pres.	Idle PC "C" Pres.	WOT PC "C" Pres.
Lincoln LS, 3.0L Engine	P/N	125-165	---	5	5
	Reverse	110-150	290-360	115	115
	D5/D4	110-150	210-260	115	115
	M5/M4	76-116	210-260	115	115
	M3	110-150	210-260	5	5
	M2/M1	92-132	210-260	5	5
Lincoln LS, 3.9L Engine	P/N	125-165	---	5	5
	Reverse	92-132	290-360	115	115
	D5/D4	110-150	210-260	115	115
	M5/M4	110-150	210-260	115	115
	M3/M2/M1	110-150	210-260	5	5

Figure 19

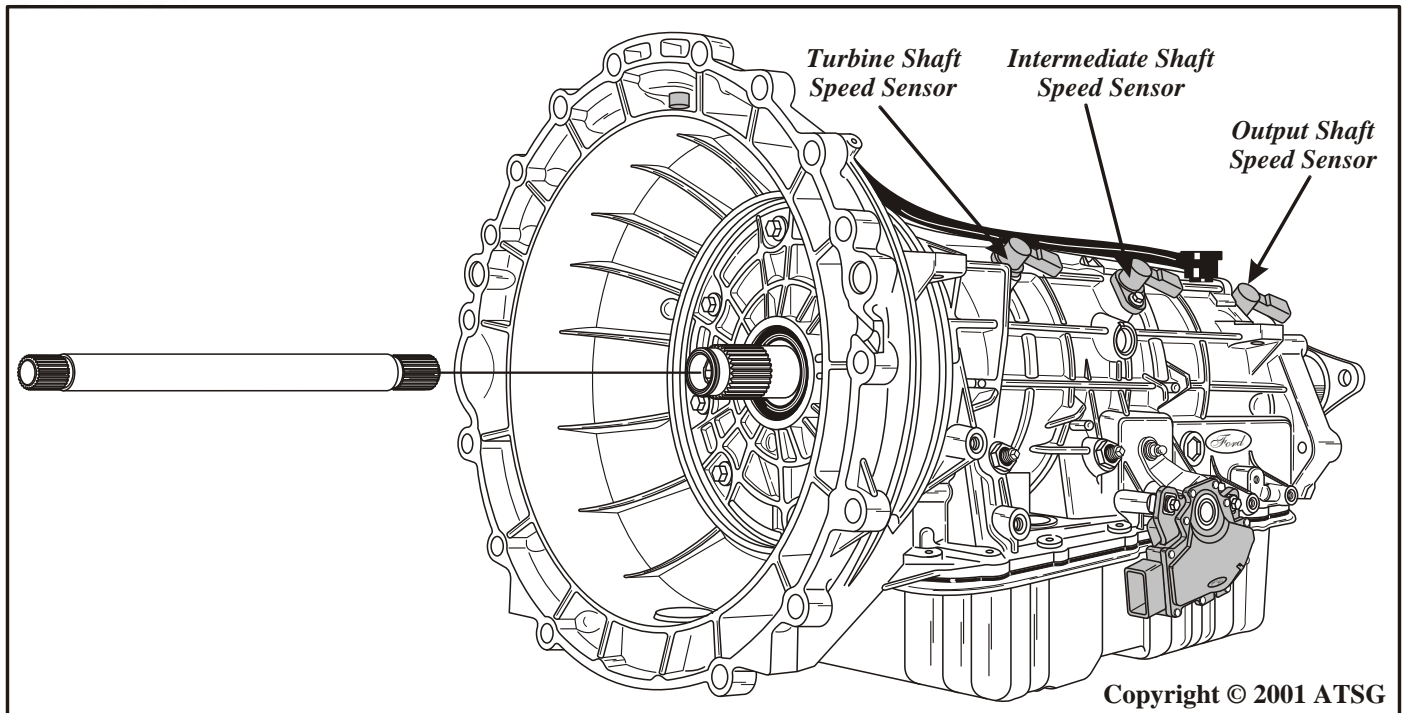

Figure 20

TRANSMISSION DISASSEMBLY EXTERNAL COMPONENTS

1. Remove the turbine shaft from the transmission as shown in Figure 20. Inspect the spline area on both ends and set aside for final assembly.
2. Remove the Turbine Shaft Sensor (TSS), the Intermediate Shaft Sensor (ISS) and the Output Shaft Sensor (OSS) from the transmission case, using a 30 Torx bit for the retaining bolts. (See Figure 20).
3. The Turbine and Output sensors are exactly the same part number. Refer to Figure 21 for the differences between them, and the Intermediate shaft speed sensor.
4. Remove and discard the "O" ring seals from all three speed sensors, and use the chart found in Figure 12 to ohms check the sensors for proper resistance readings.

Continued on Page 24

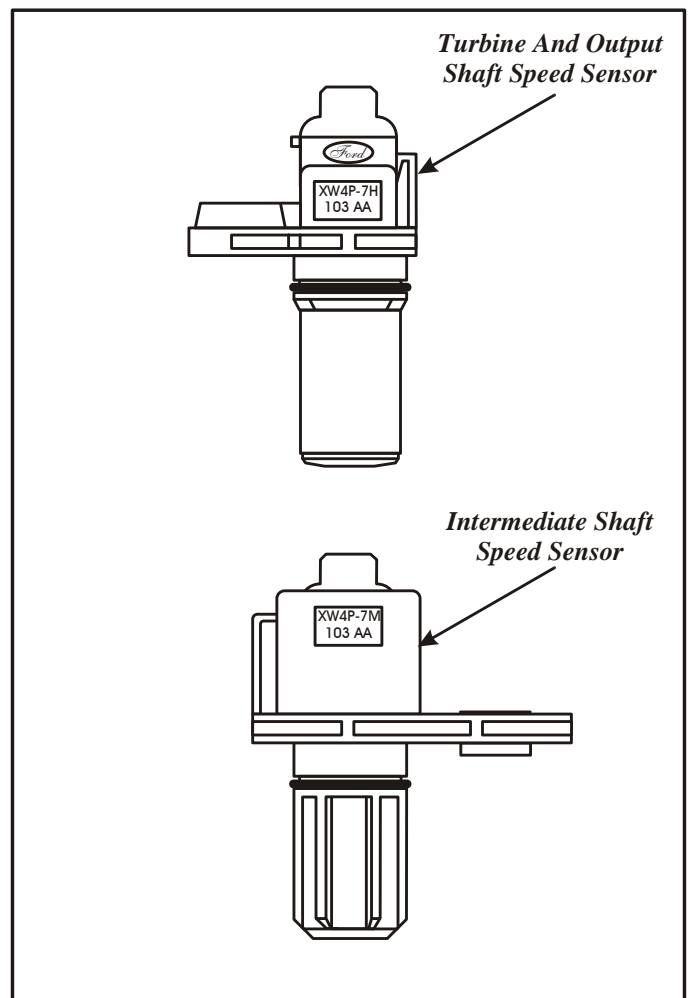

Figure 21

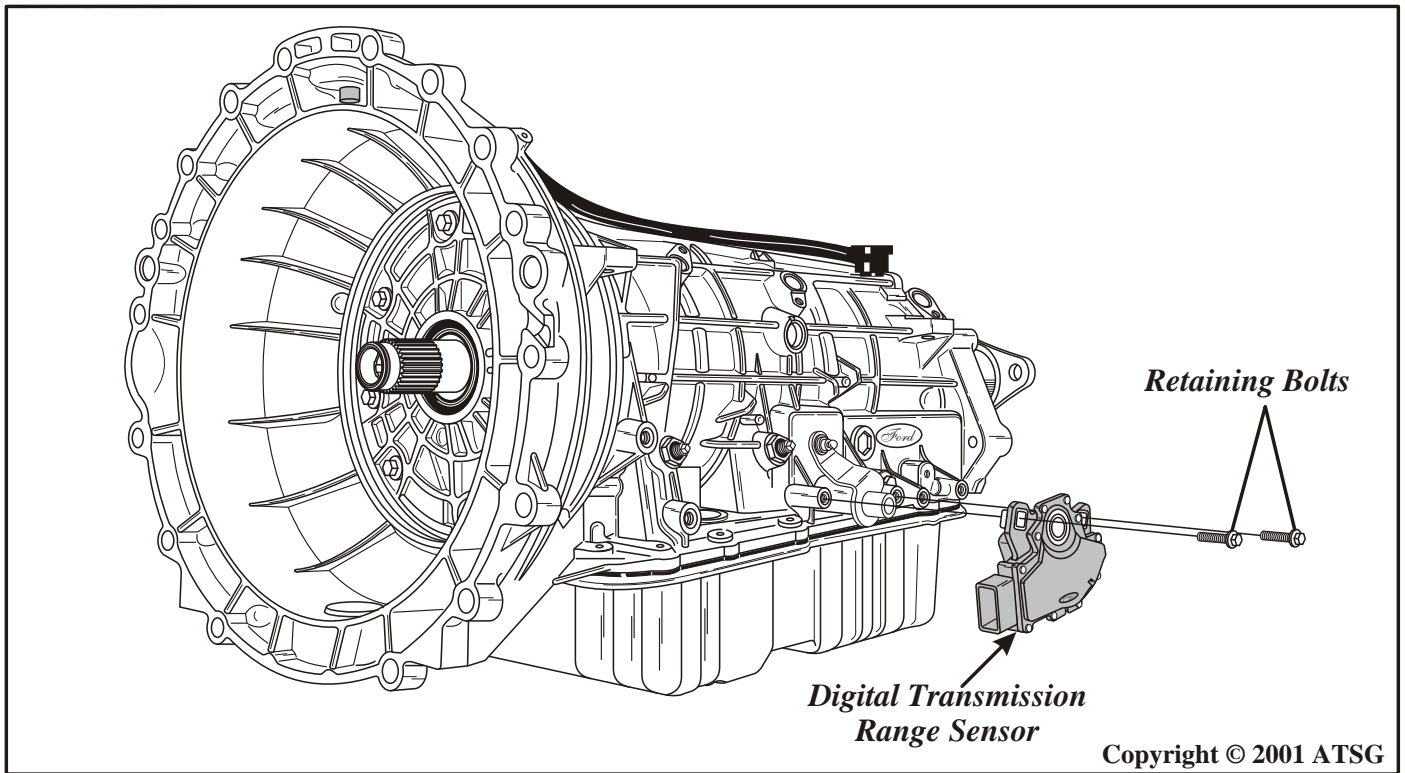

Figure 22

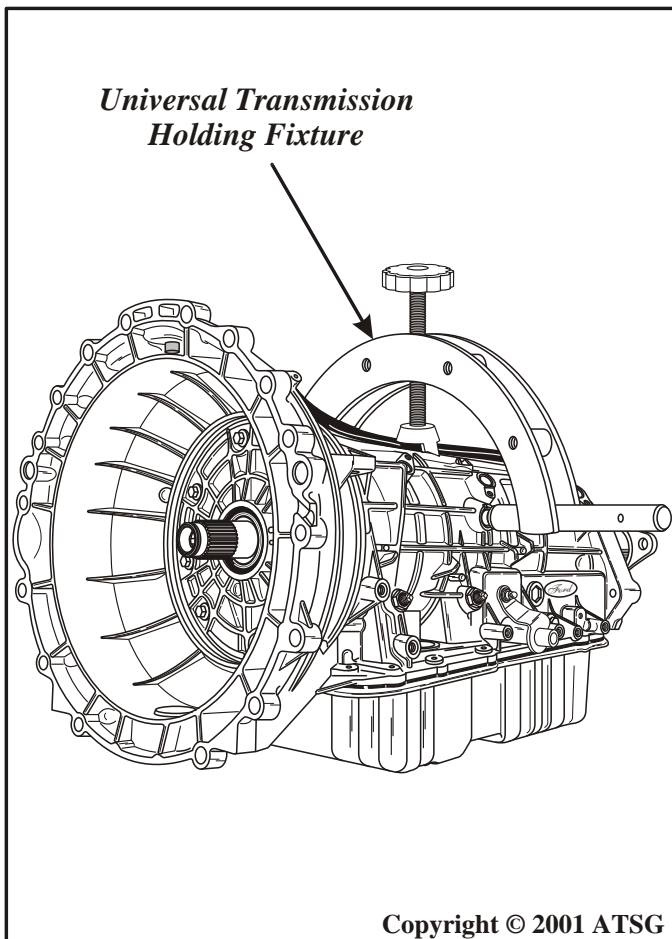

Figure 23

EXTERNAL COMPONENTS (Cont'd)

5. Remove the two Digital Transmission Range sensor retaining bolts, as shown in Figure 22, and remove the sensor.
6. Install a compatible holding fixture onto the transmission case, as shown in Figure 23, that will allow you to rotate the transmission when installed in the bench fixture.
7. Install the transmission into the bench fixture and rotate, so that extension housing is facing up, as shown in Figure 24.
8. Remove and discard the output flange retaining nut, as shown in Figure 24.
9. Using an appropriate puller, remove the output flange, as shown in Figure 24.
10. Remove the seven extension housing retaining bolts, using a 10mm socket (See Figure 25).
11. Remove the extension housing and discard the gasket, as shown in Figure 25.

Caution: *The parking pawl, parking pawl return spring and parking pawl shaft may fall out of extension housing during removal.*

Continued on Page 26

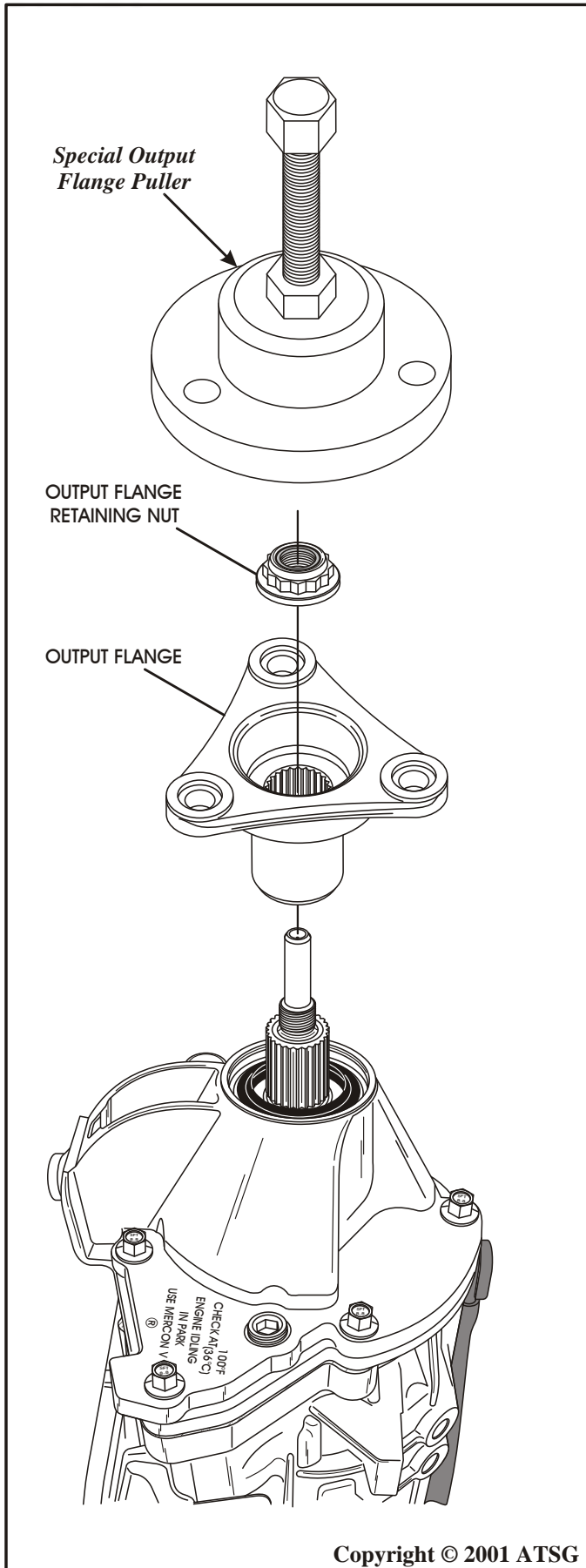

Figure 24

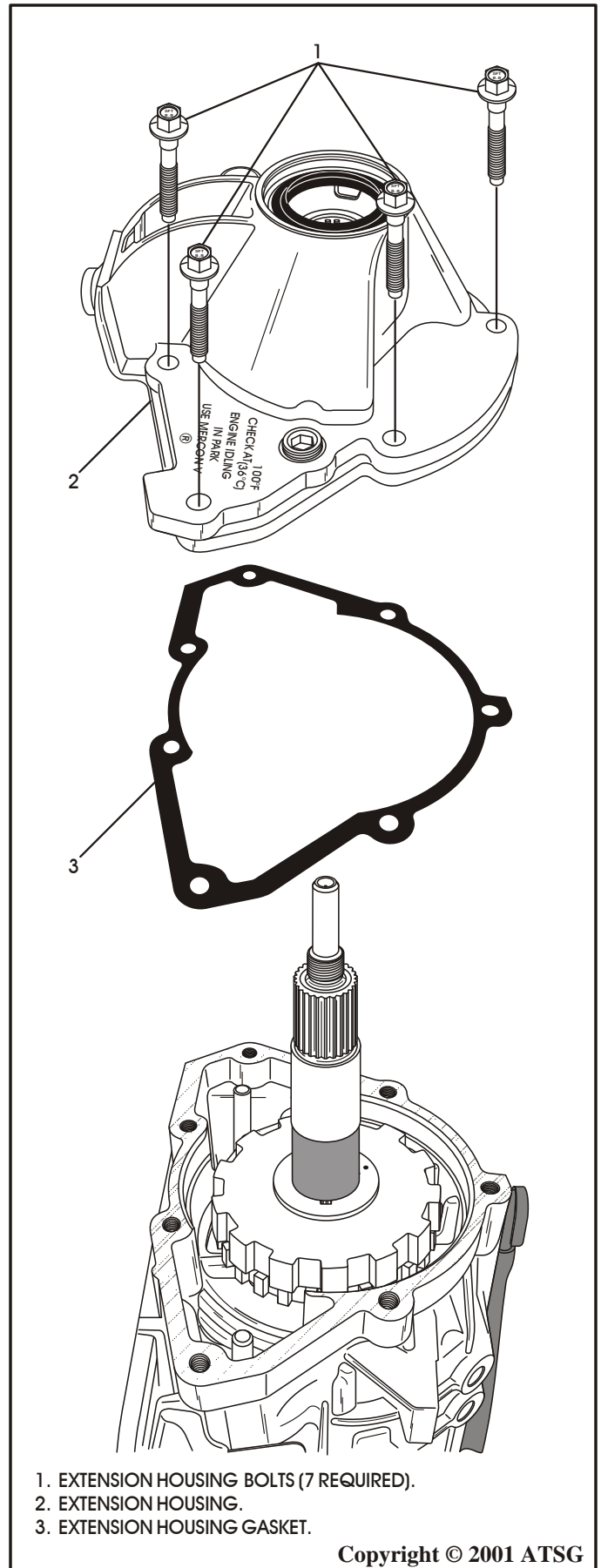

Figure 25

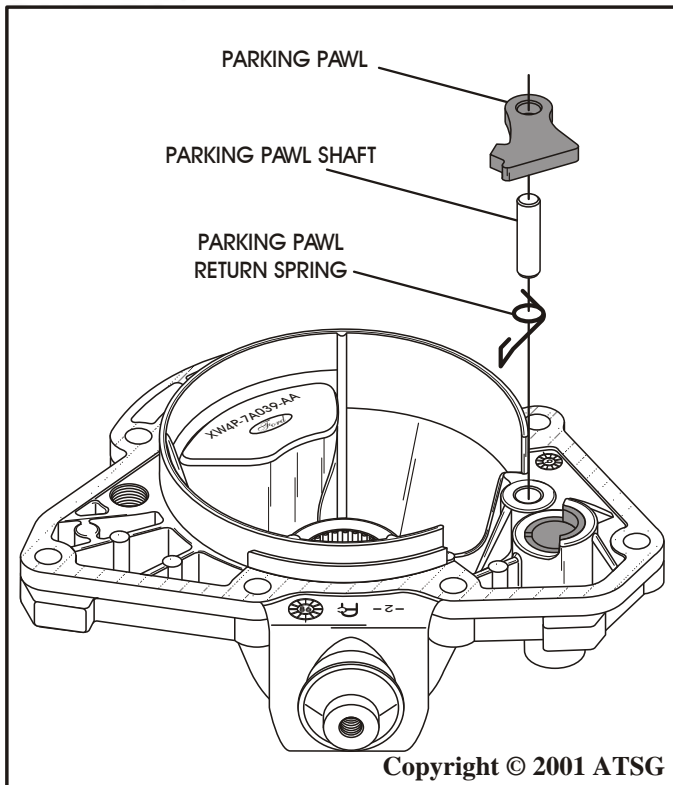

Figure 26

EXTERNAL COMPONENTS (Cont'd)

12. If the parking pawl, parking pawl return spring and parking pawl shaft remain in the extension housing, remove them as shown in Figure 26.
13. Rotate the transmission so that the bottom pan is facing up, as shown in Figure 27.
14. Remove the sixteen bottom pan bolts using an 8mm socket and remove oil pan, as shown in Figure 28.
15. Remove the bottom pan gasket from the case, as shown in Figure 28.

Note: The bottom pan gasket is reusable. Clean and inspect the gasket for damage, and if it is not damaged, it may be re-used.

Continued on Page 28

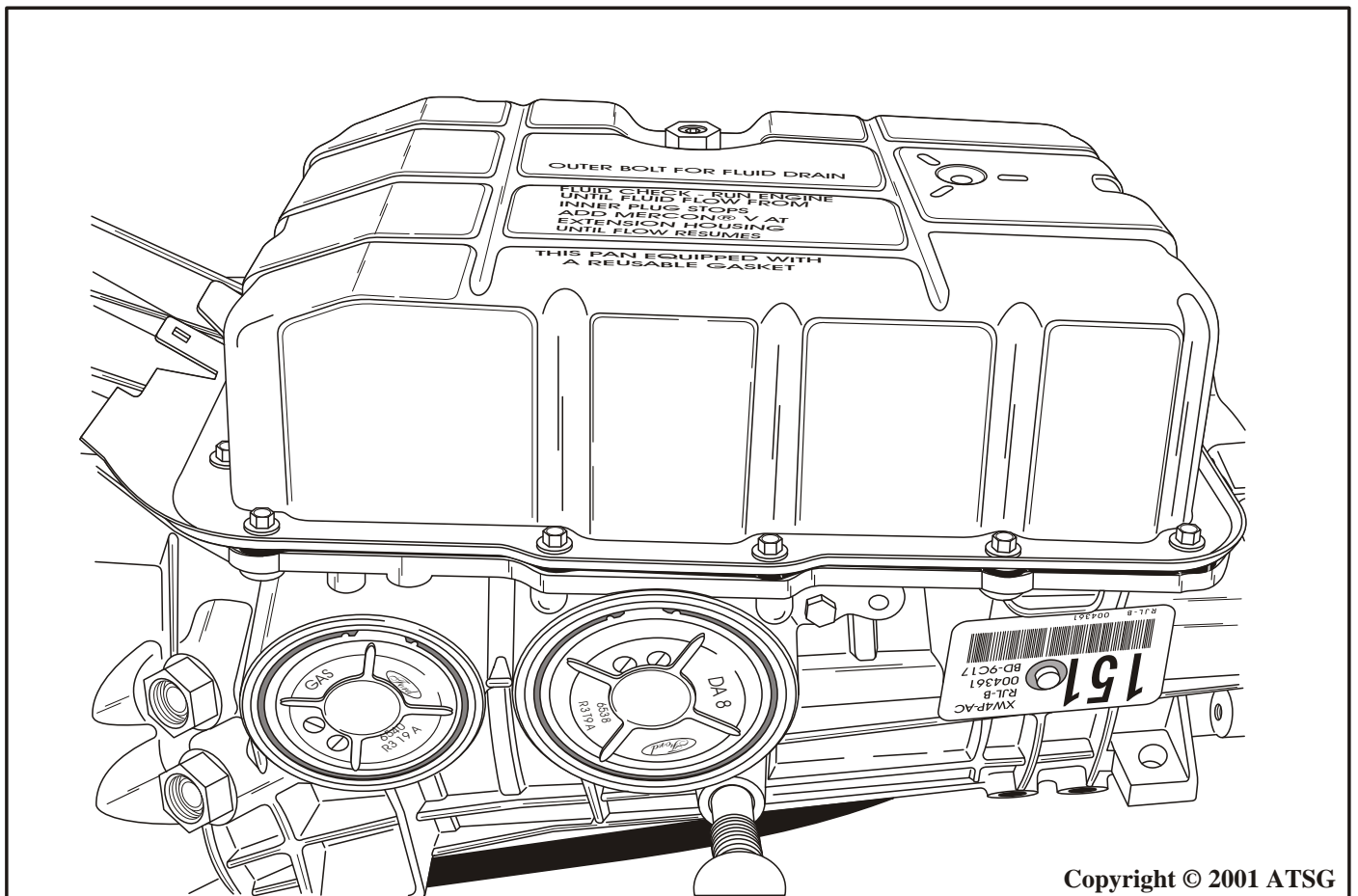
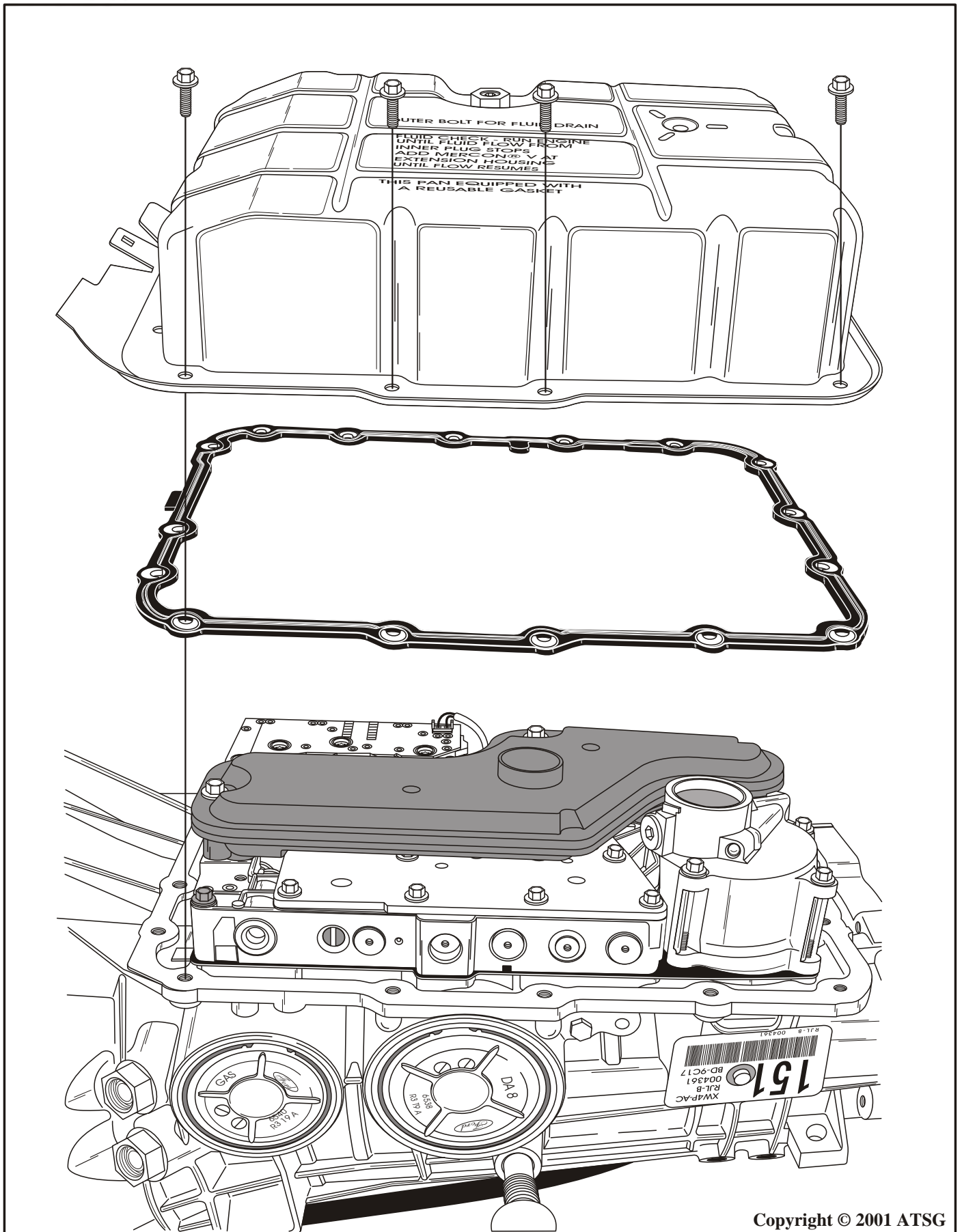

Figure 27



Copyright © 2001 ATSG

Figure 28

EXTERNAL COMPONENTS (Cont'd)

16. Remove the two filter retaining bolts using an 8mm socket as shown in Figure 29.
17. Discard the oil filter and seals (See Figure 29).
18. Remove the two reverse pressure switch bolts, disconnect the switch from solenoid assembly and remove reverse pressure switch, as shown in Figure 30.

19. Remove the four retaining bolts from reverse servo assembly using an 8mm socket and remove the reverse servo assembly, as shown in Figure 30.

Note: Ford Motor Co. recommends discarding this switch and replacing on every rebuild.

Continued on Page 30

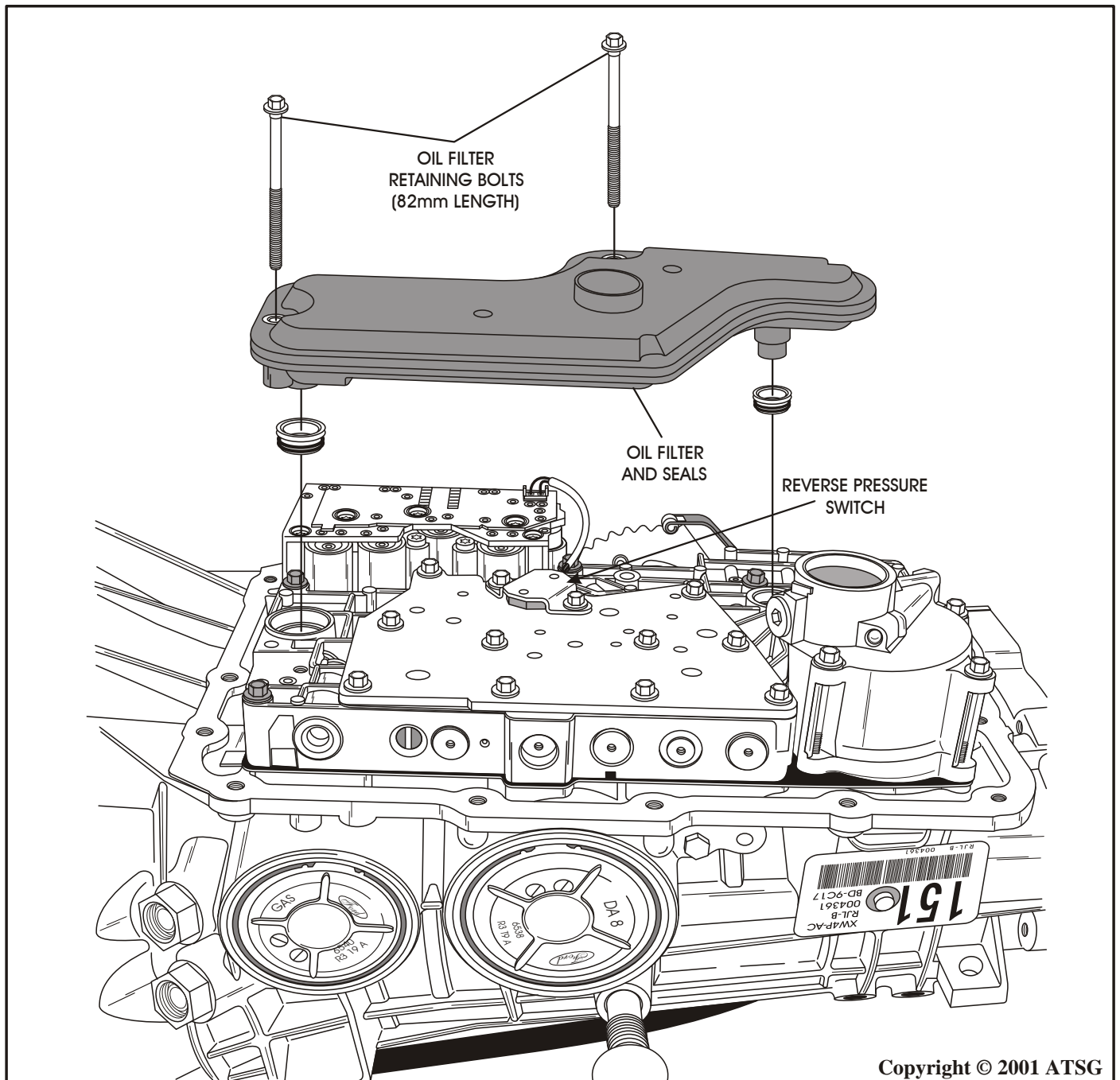

Figure 29

Copyright © 2001 ATSG

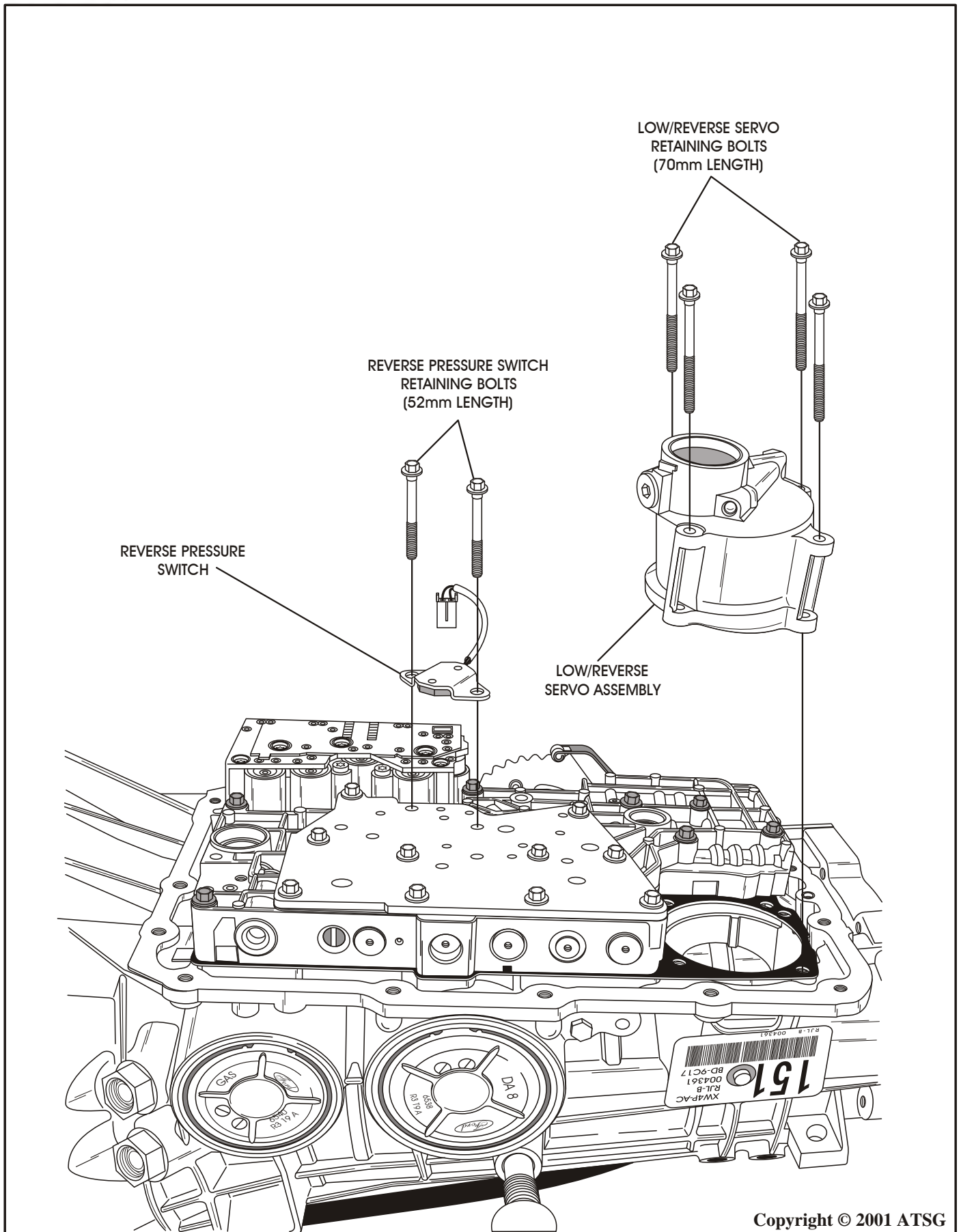

Figure 30

EXTERNAL COMPONENTS (Cont'd)

20. Remove the 10 remaining valve body cover plate bolts using an 8mm socket, as shown in Figure 31.
21. Remove the valve body cover plate, remove and discard the cover plate gasket, as shown in Figure 31.
22. Remove the solenoid body retaining bolts using a 30 Torx bit, as shown in Figure 32.
23. Remove the solenoid body assembly from the transmission, as shown in Figure 32, and set aside for testing in component rebuild.

Continued on Page 32

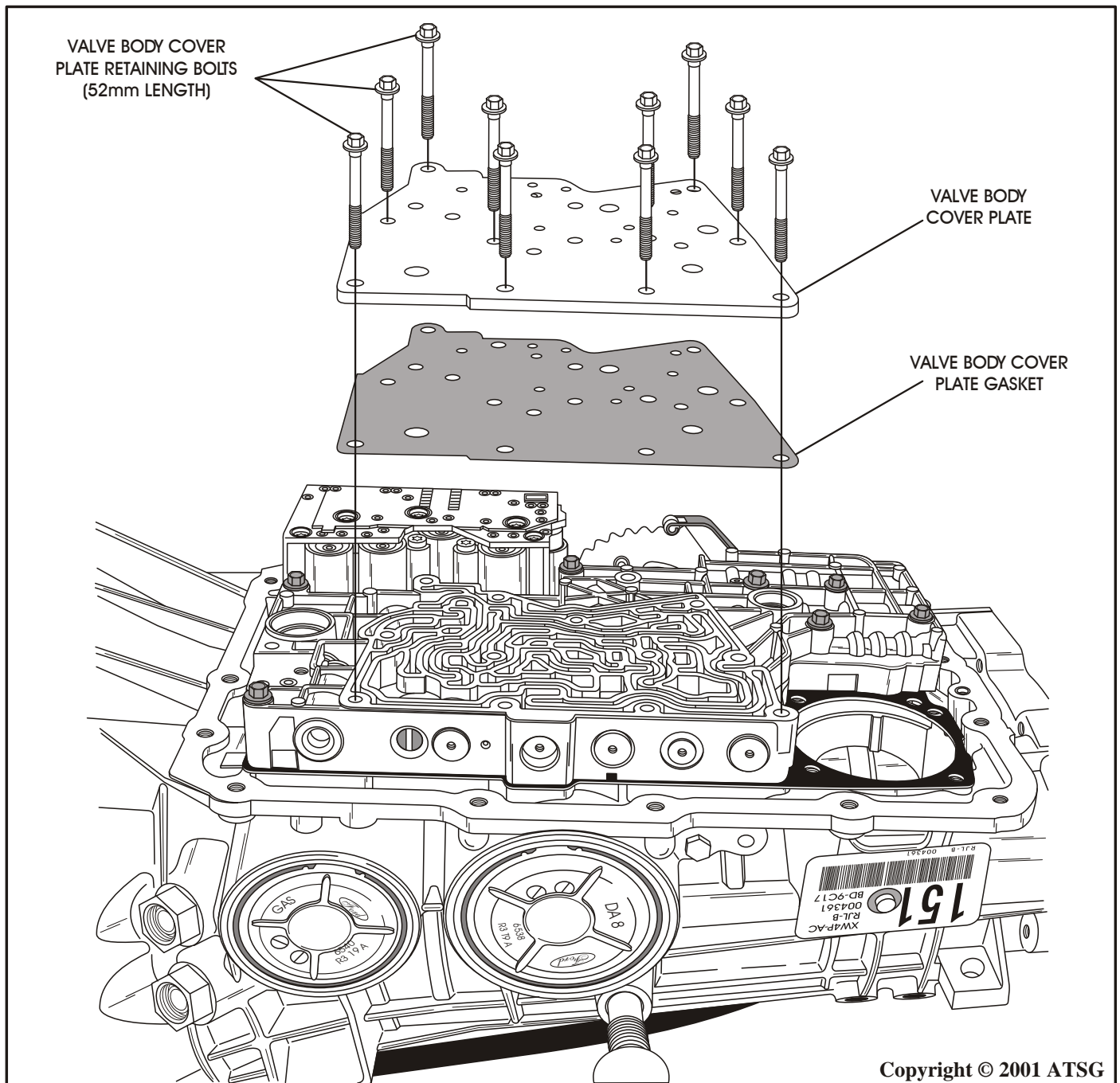
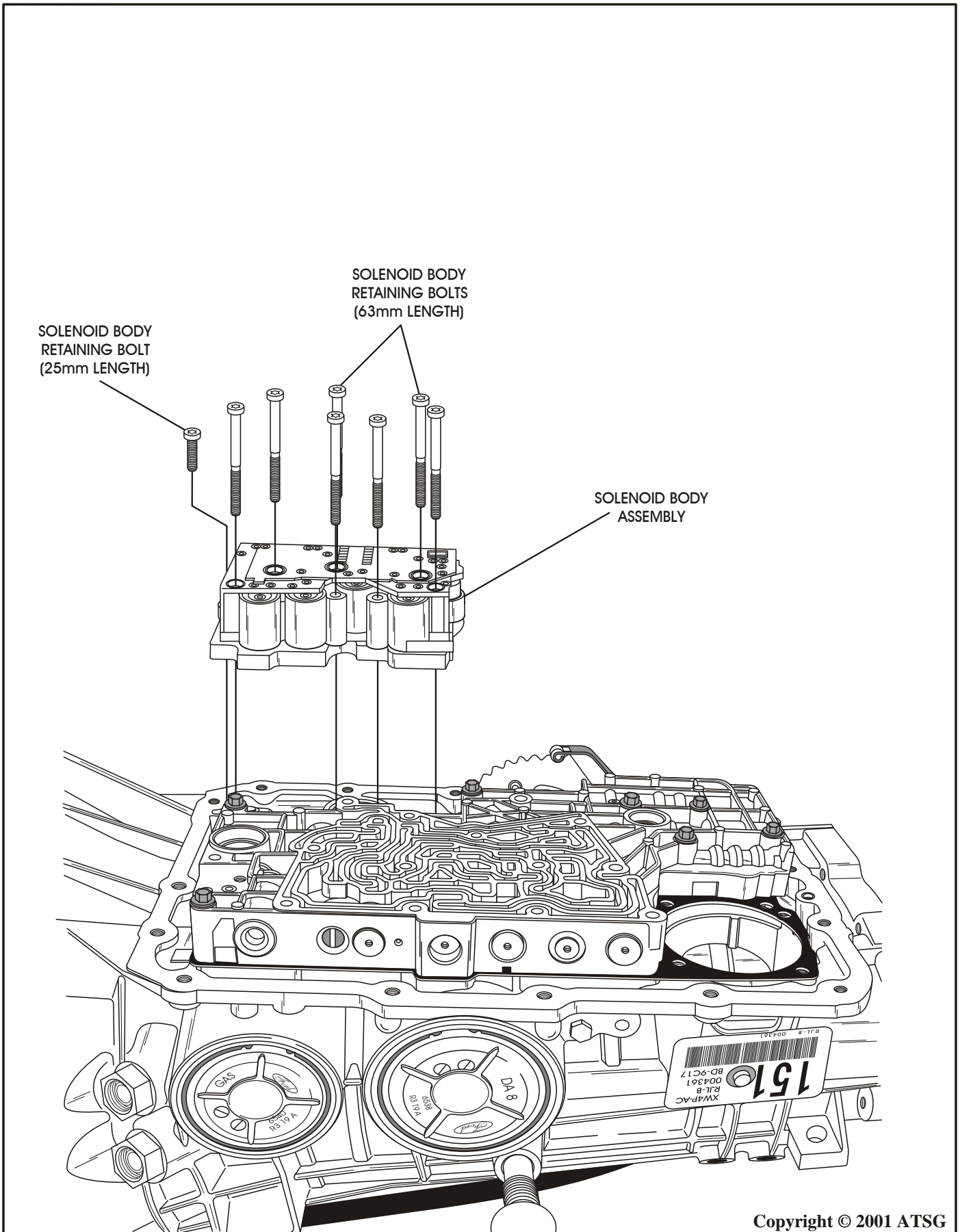

Figure 31



Copyright © 2001 ATSG

Figure 32

EXTERNAL COMPONENTS (Cont'd)

24. Remove the retaining bolt for the detent spring and remove detent spring (See Figure 33).
Note the length of this bolt.
25. Remove the valve body retaining bolt directly in front of the detent spring (See Figure 33).
Note the length of this bolt.
26. Remove the remaining 7 valve body retaining bolts, as shown in Figure 33.

27. Remove the complete valve body and spacer plate assembly and set aside for the component rebuild section (See Figure 33).
28. Remove the intermediate clutch seal retaining spring, remove and discard the intermediate clutch seal, as shown in Figure 34.
29. **Caution: "Do Not" yet remove the center support bolt, as nut may fall into unit.**

Continued on Page 33

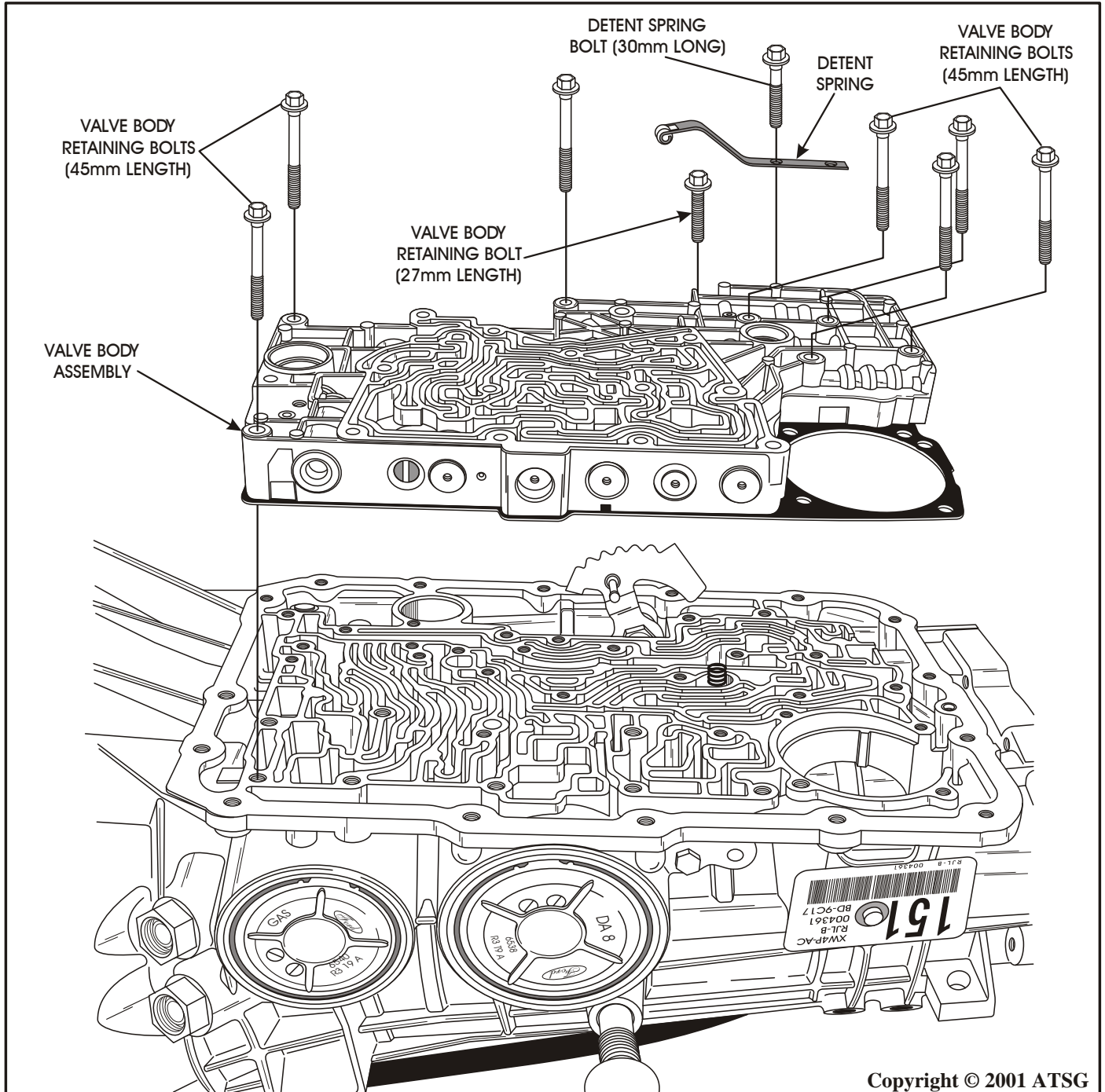

Figure 33

Copyright © 2001 ATSG

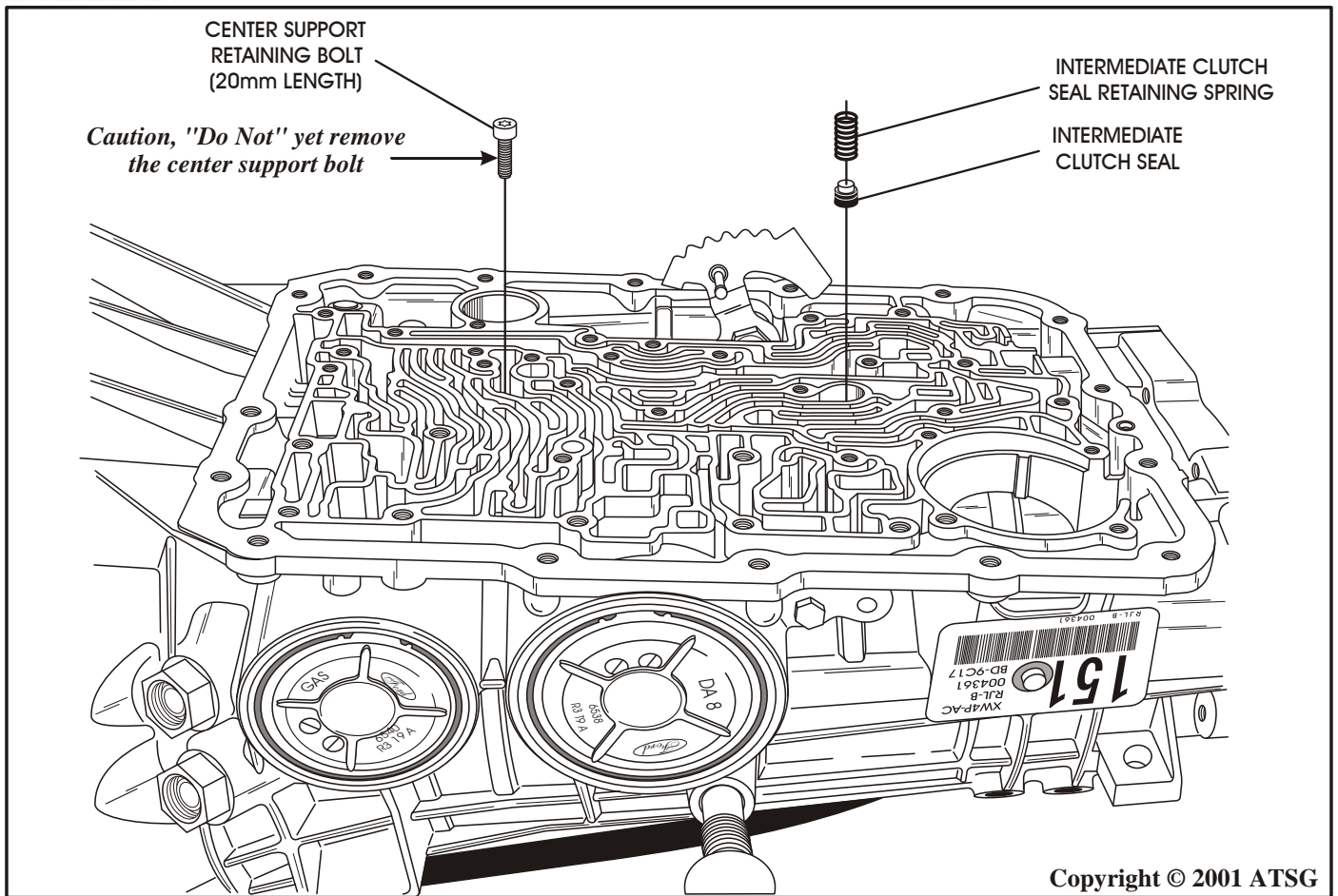

Figure 34

EXTERNAL COMPONENTS (Cont'd)

30. Loosen both band adjusting screws, as shown in Figure 35.
31. **Caution:** Failure to loosen OD band adjusting screw prior to pump removal may cause damage to the pump or OD band.
32. Remove and discard the locknuts from the band adjusting screws, as they are not reusable.

Continued on Page 34

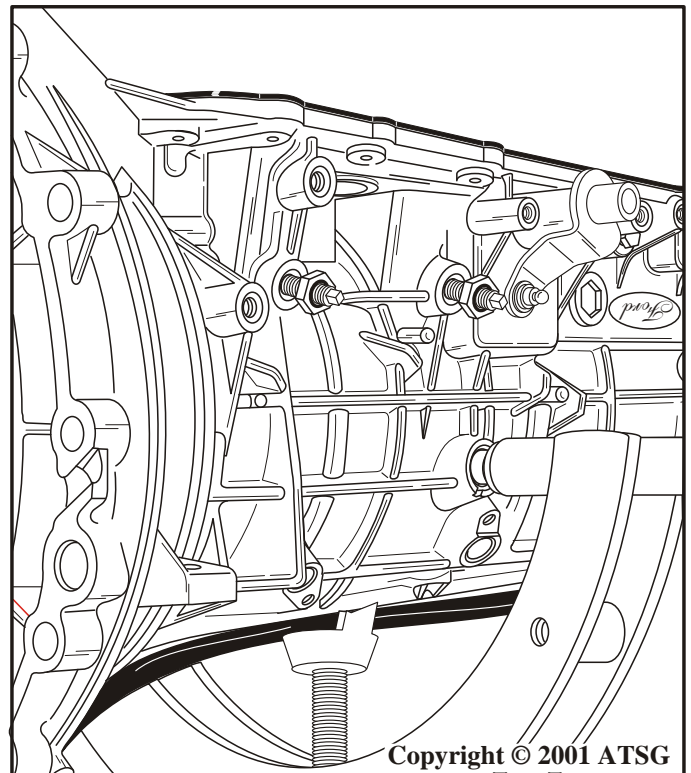

Figure 35

INTERNAL COMPONENTS (Cont'd)

33. Rotate the transmission in bench fixture so that the pump is facing up, as shown in Figure 36.
34. Install the special pump puller, to be used with a slide hammer, as shown in Figure 37.
35. Remove the eight oil pump retaining bolts, as shown in Figure 38.

Note: Ford Motor Co. recommends that the pump bolts not be reused, but replaced.

Continued on Page 35

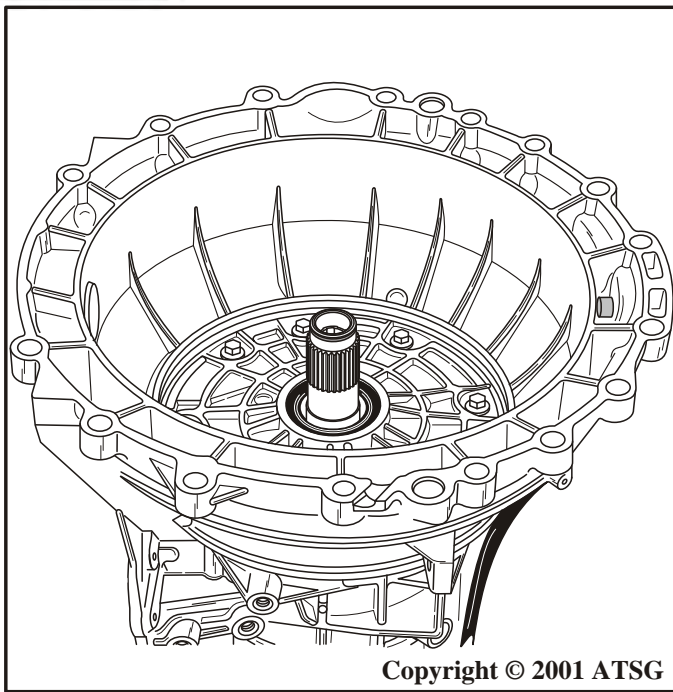

Copyright © 2001 ATSG

Figure 36

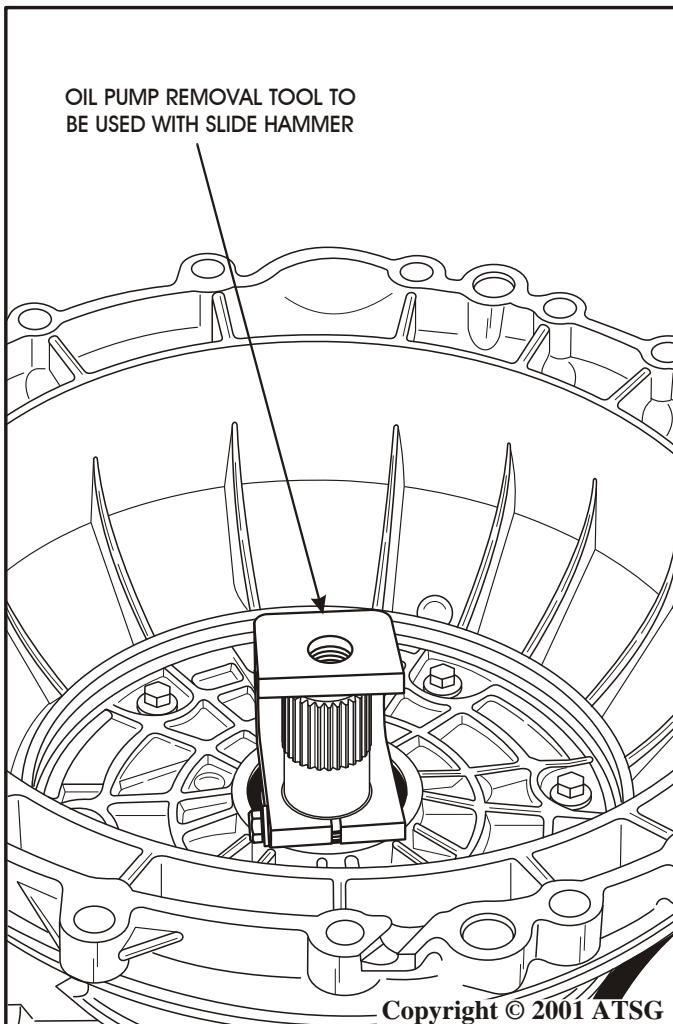

OIL PUMP REMOVAL TOOL TO BE USED WITH SLIDE HAMMER

Copyright © 2001 ATSG

Figure 37

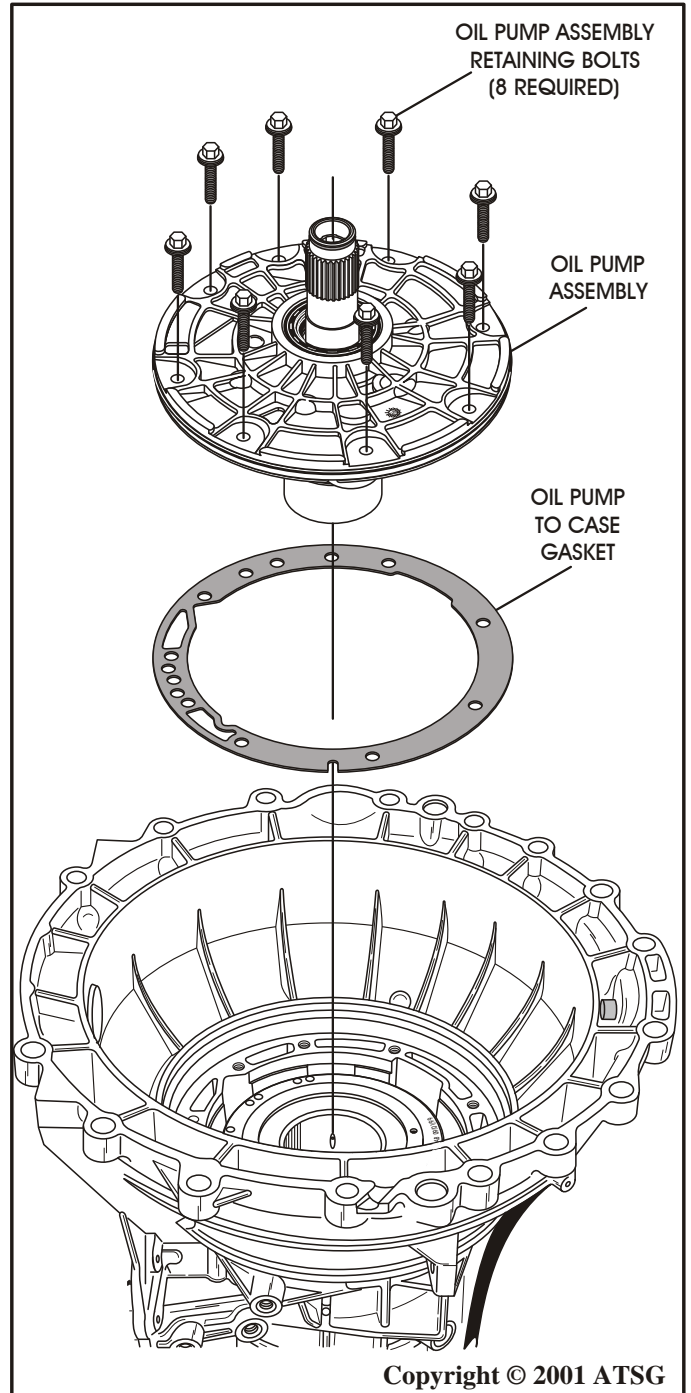

OIL PUMP ASSEMBLY
RETAINING BOLTS
(8 REQUIRED)

OIL PUMP
ASSEMBLY

OIL PUMP
TO CASE
GASKET

Copyright © 2001 ATSG

Figure 38

INTERNAL COMPONENTS (Cont'd)

36. Using the special pump removal tool and your slide hammer, remove the oil pump assembly, as shown in Figure 38.
37. Set the oil pump assembly aside for component rebuild section in this manual.
38. Remove the OD/Coast clutch drum assembly, as shown in Figure 39, and set drum aside for the component rebuild section.
39. Remove the overdrive band assembly and both band struts, as shown in Figure 40.

Note: Notice the difference in the band struts and which side they are located, as shown in Figure 40.
40. Remove the coast clutch drum adapter and the overdrive sun gear from the overdrive carrier, as shown in Figure 41.

Continued on Page 36

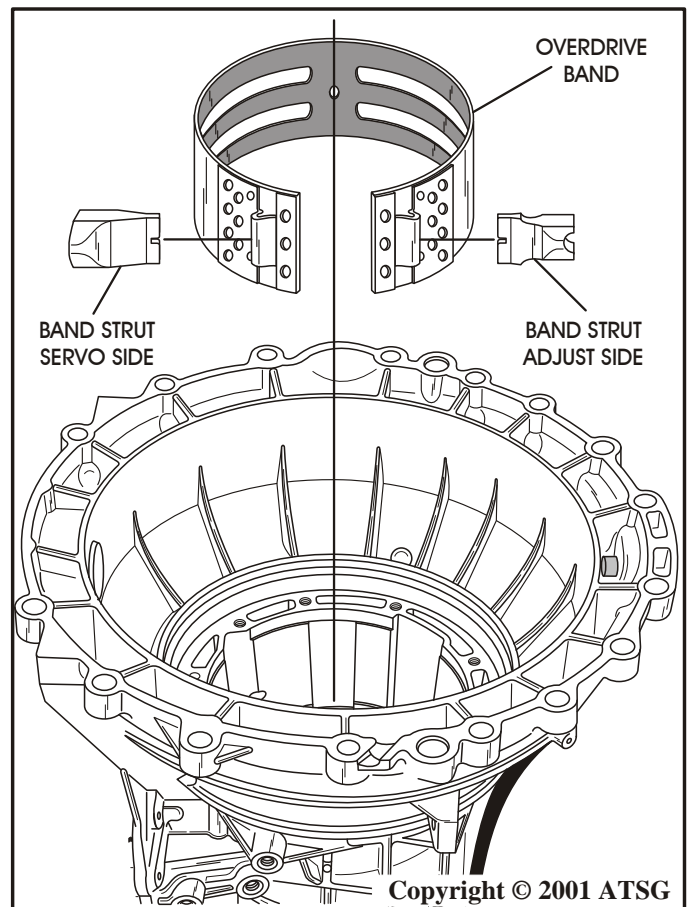

Figure 40

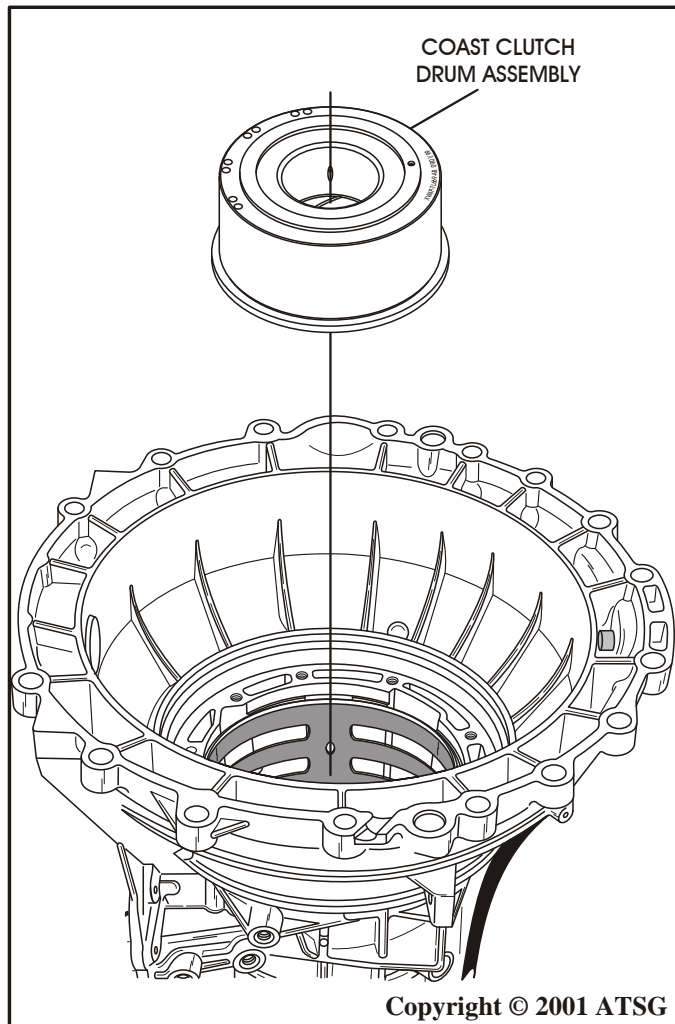

Figure 39

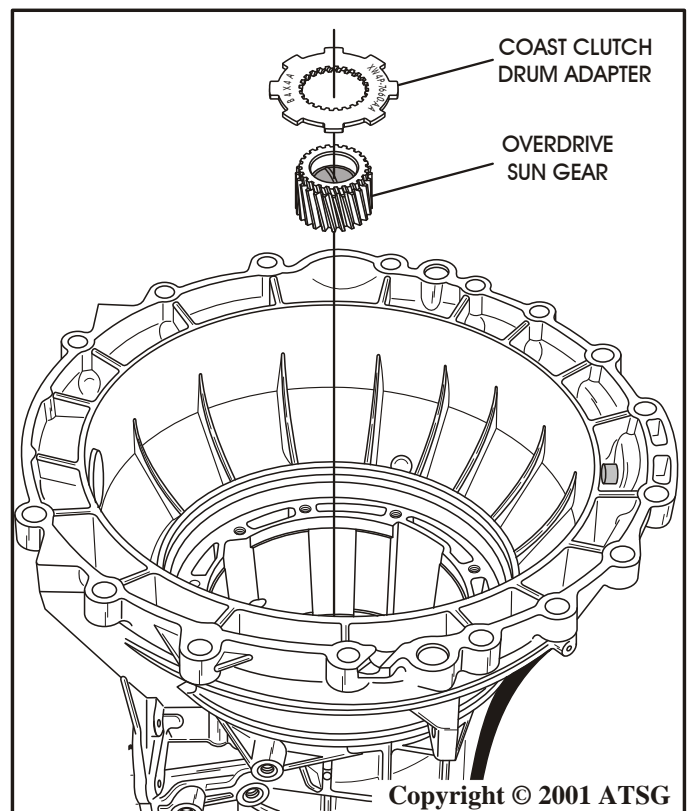

Figure 41

INTERNAL COMPONENTS (Cont'd)

41. Remove the overdrive carrier and center shaft assembly, as shown in Figure 42.
42. Now, remove the center support retaining bolt from the case, as shown in Figure 43, and also remove the locknut, as shown in Figure 44, to prevent it from falling into the assembly.
43. Remove the center support retaining snap ring from the case, as shown in Figure 44.
44. Remove center shaft thrust bearing (No. 3) from the center support, as shown in Figure 44 and tag it for I.D. and location.

Continued on Page 37

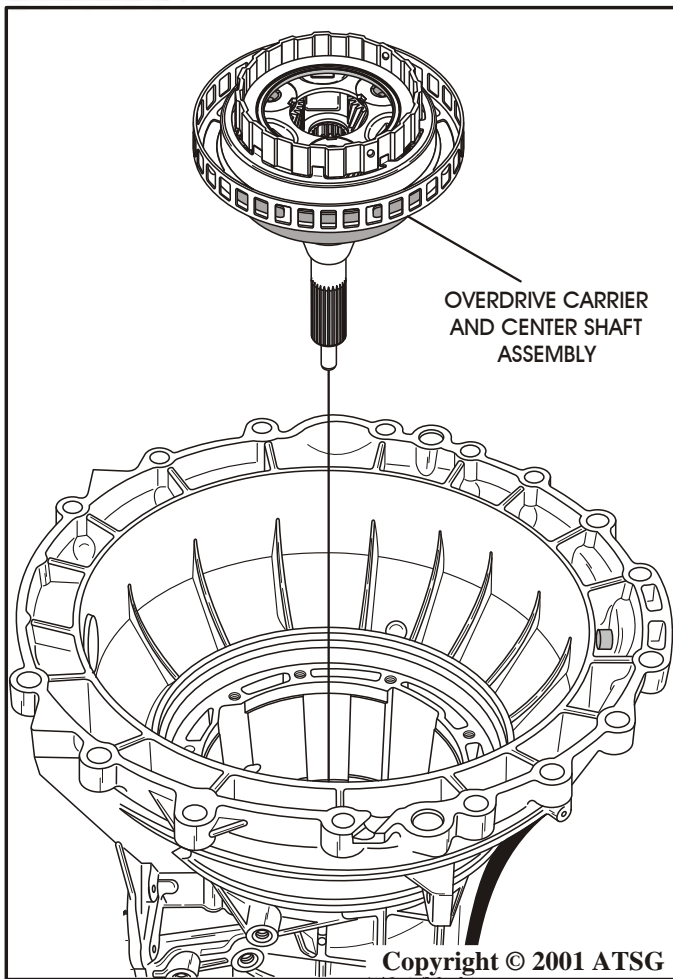

Figure 42

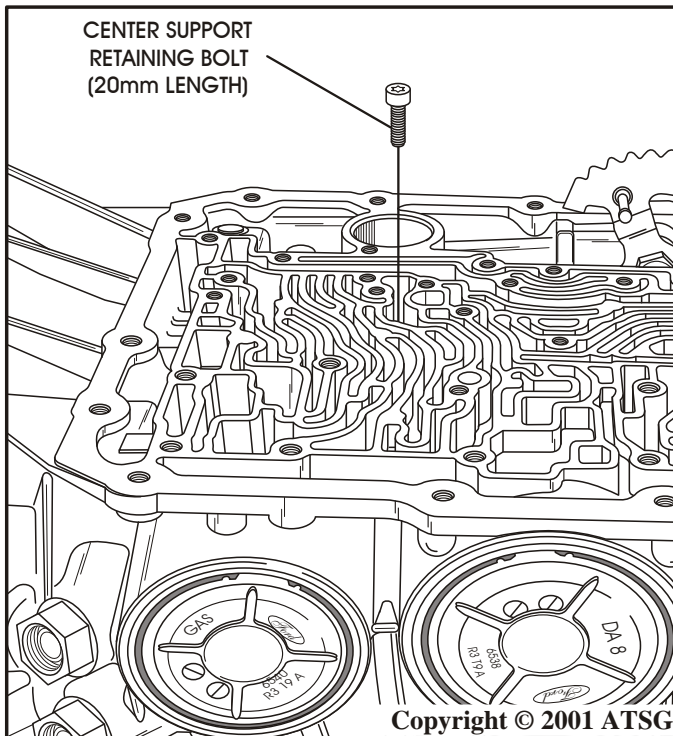

Figure 43

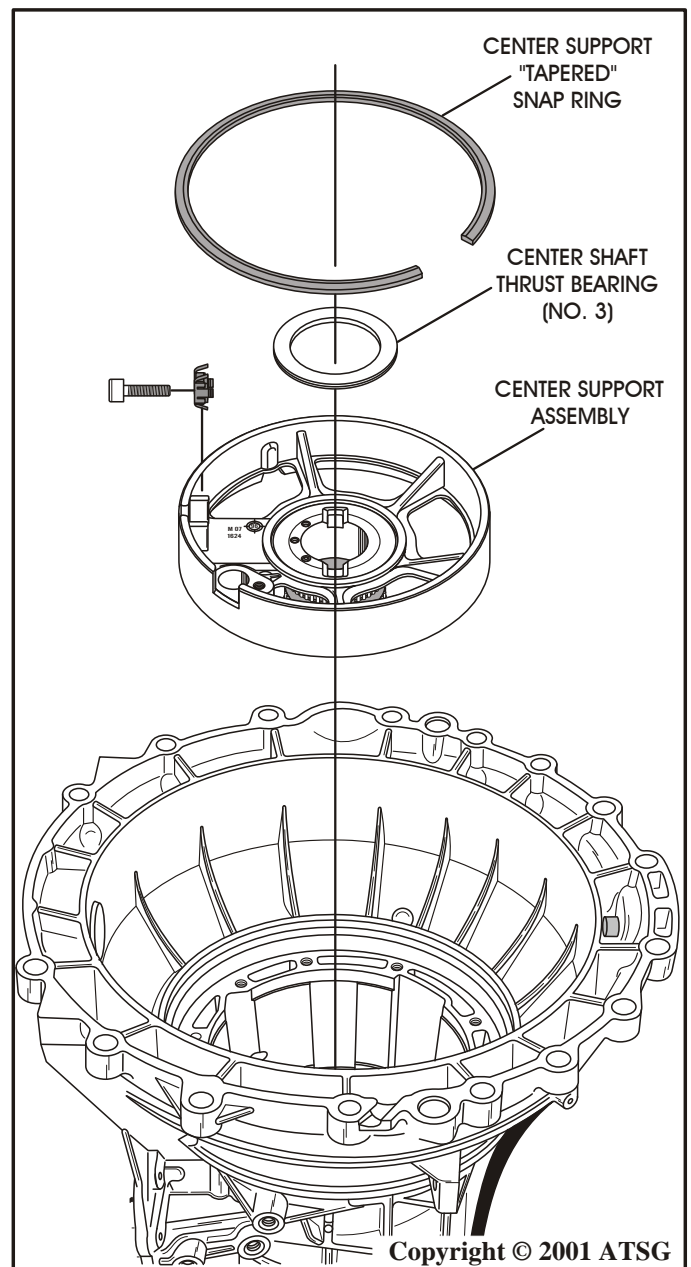

Figure 44

INTERNAL COMPONENTS (Cont'd)

45. Remove the center support and set aside for component rebuild, as shown in Figure 44.
46. Remove the intermediate band assembly and both band struts, as shown in Figure 45.
Note: Notice the difference in the band struts and which side they are located, as shown in Figure 45.
47. Remove and tag for I.D. direct clutch (No. 4) *selective* thrust bearing, as shown in Figure 46.
48. Remove the direct clutch housing assembly and set aside for component rebuild, as shown in Figure 46.
49. Remove and tag for I.D. forward clutch (No. 5) thrust bearing, as shown in Figure 46.
50. Remove the forward clutch housing assembly and set aside for component rebuild, as shown Figure 46.
51. Remove and tag for I.D. the forward clutch (No. 6A) thrust bearing (See Figure 46).
Note: This bearing may stick to the forward clutch housing during removal.

Continued on Page 38

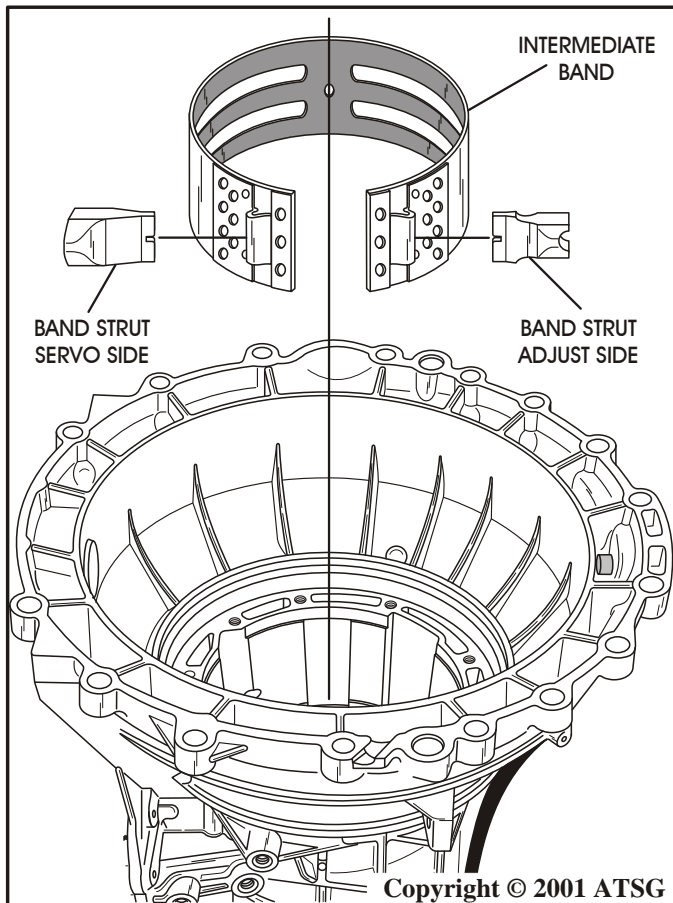

Figure 45

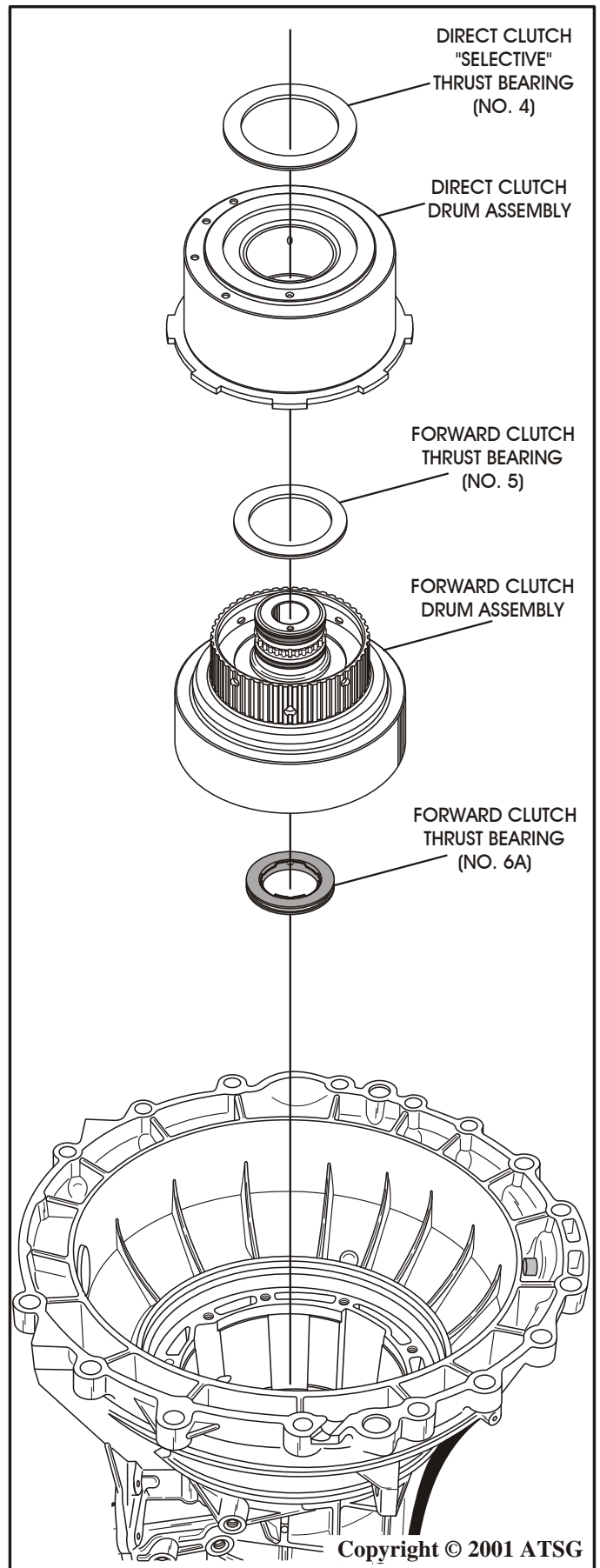

Figure 46

INTERNAL COMPONENTS (Cont'd)

52. Remove forward ring gear and hub assembly along with the forward clutch (No. 6B) thrust washer, as shown in Figure 47.
53. Remove and tag for I.D. the forward planet (No. 7) thrust bearing (See Figure 47).
Note: Bearing may come out with the forward ring gear and hub assembly.
54. Remove the forward planetary carrier assembly as shown in Figure 47.

55. Remove the input sun gear and shell assembly, as shown in Figure 48.
Note: Intermediate Sprag assembly may come out with sun gear and shell.
56. Remove the low/reverse bearing spacer from inside the intermediate clutch pack, as shown in Figure 48.

Continued on Page 39

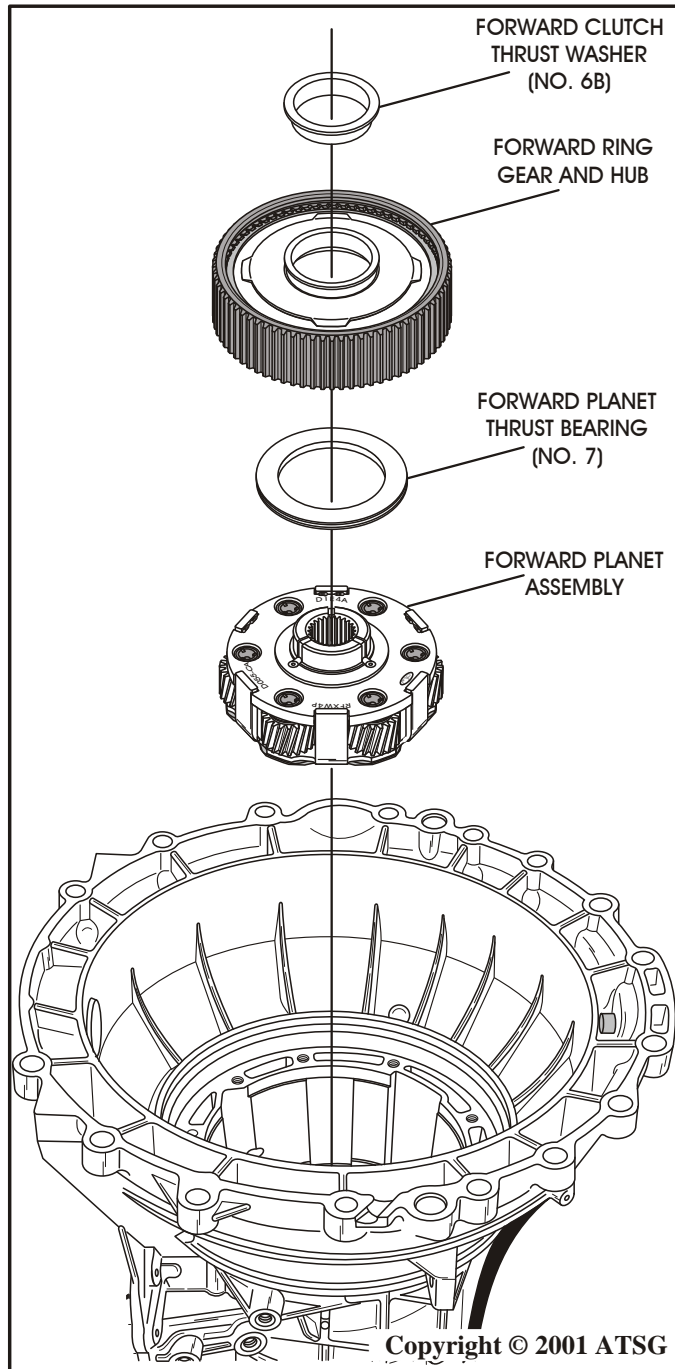

Figure 47

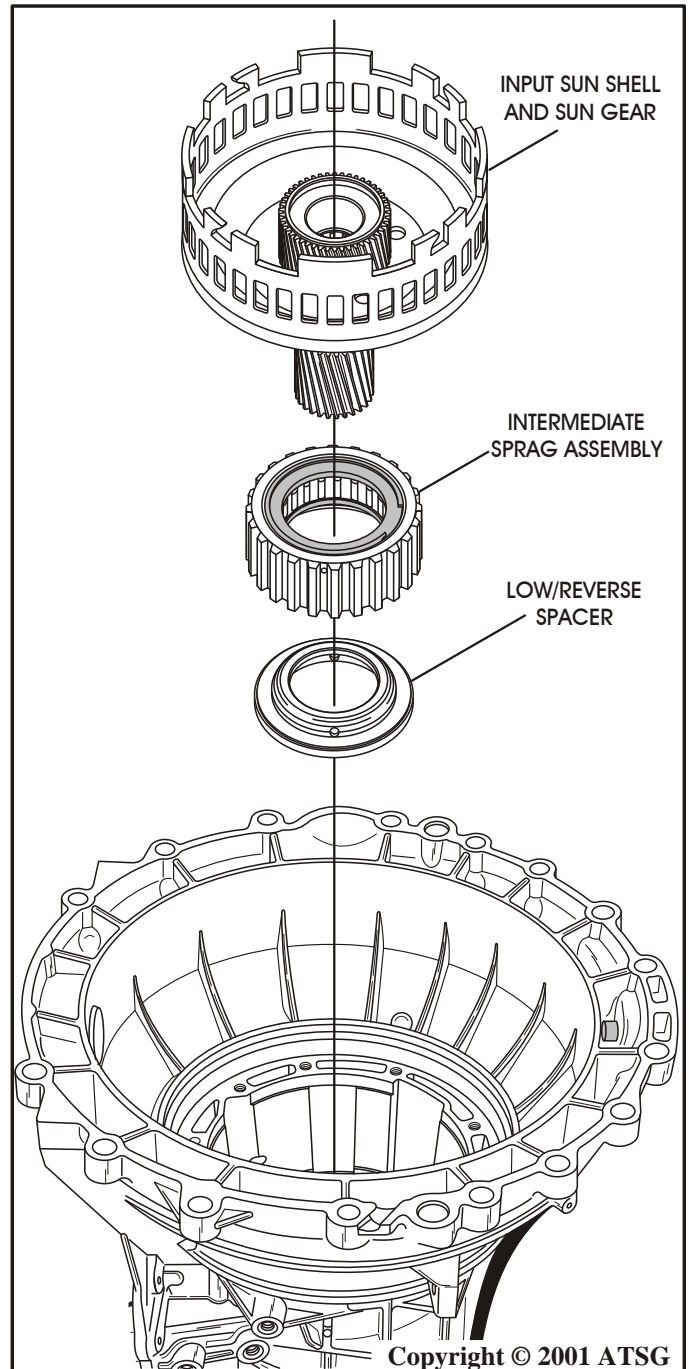

Figure 48

INTERNAL COMPONENTS (Cont'd)

57. Install Special Tool 307-401, to compress the intermediate clutch return spring, as shown in Figure 49.
58. Compress the intermediate clutch return spring and remove the "Flat" retaining snap ring for intermediate clutch piston retainer, as shown in Figure 50.
59. Remove Special Tool 307-401.
60. Remove the intermediate piston retainer and piston assembly and set aside for component rebuild section (See Figure 50).
61. Remove the complete intermediate clutch pack assembly, as shown in Figure 50, and set aside for component rebuild section.

Continued on Page 40

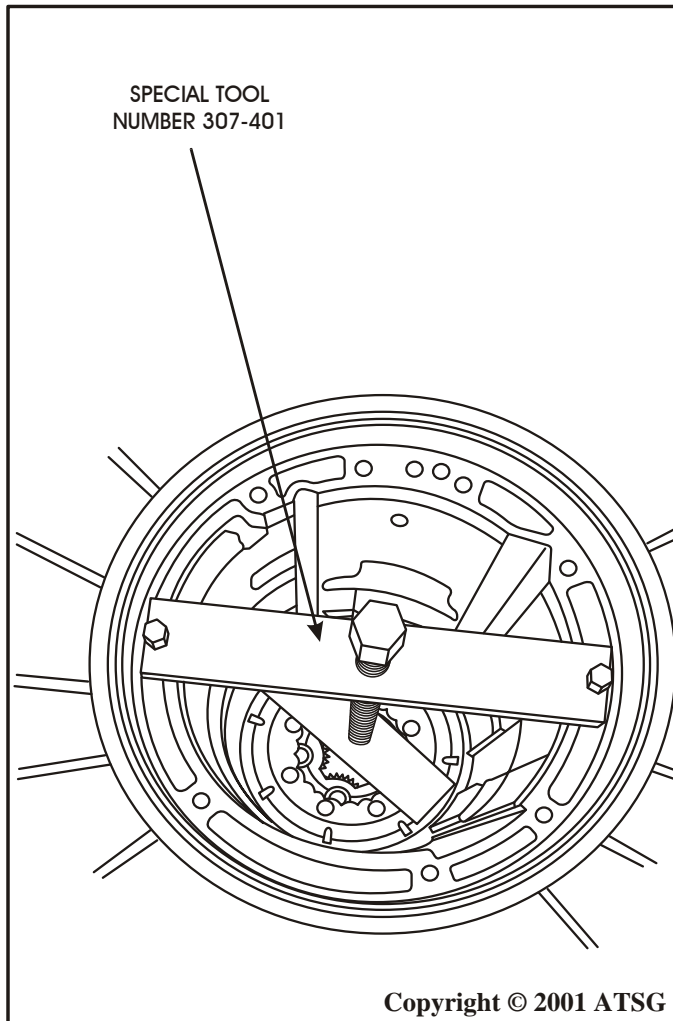

Figure 49

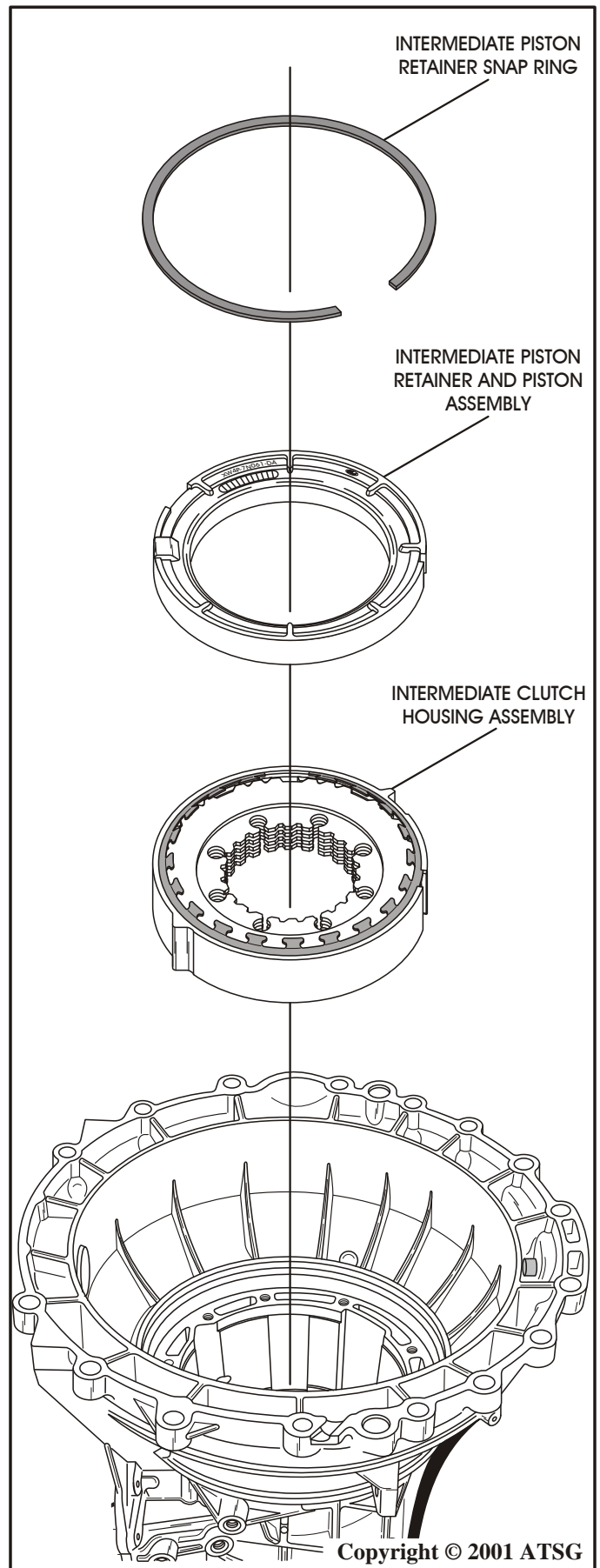

Figure 50

INTERNAL COMPONENTS (Cont'd)

62. Remove and tag for I.D. the rear planetary thrust bearing (No. 8), as shown in Figure 51.
63. Remove the rear planetary retaining snap ring from reverse drum, as shown in Figure 51.
64. Remove the rear planetary carrier from the reverse drum, as shown in Figure 51.
65. Remove the plastic lube dam from the rear planetary ring gear, as shown in Figure 52.
66. Remove the output shaft retaining snap ring from the output shaft, as shown in Figure 52.
Caution: Hold the output shaft while you are removing the snap ring so it does not fall out. Ford Motor Co. also recommends replacing the output shaft snap ring.
67. Remove the output shaft from transmission, from the rear side, so that it does not fall out and cause injury.
68. Remove and tag the rear ring gear, number 9, thrust bearing for I.D. (See Figure 52).
69. Remove the rear planetary ring gear from the transmission, as shown in Figure 52.
70. Remove reverse drum and low sprag assembly by rotating and lifting drum out, as shown in Figure 53.
71. Remove and tag the number 10 thrust bearing for I.D. as shown in Figure 53.
72. Remove the low/reverse band assembly from the case, as shown in Figure 53.

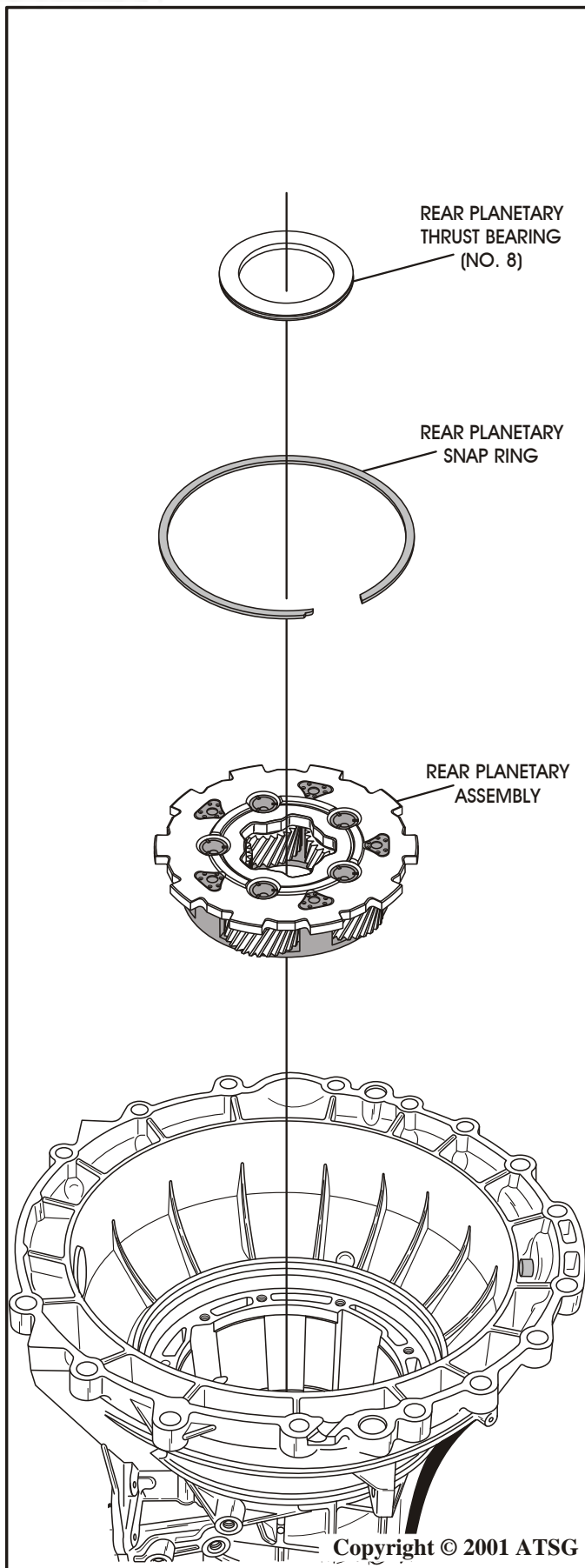

Figure 51

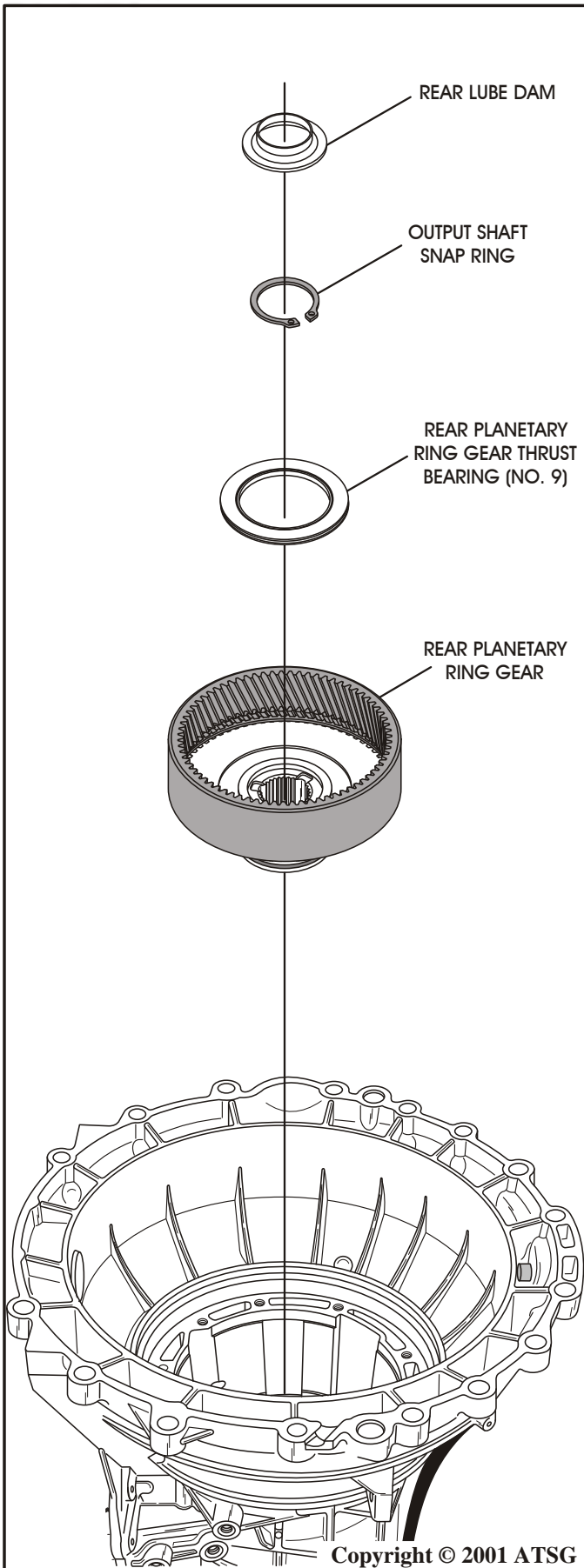

Figure 52

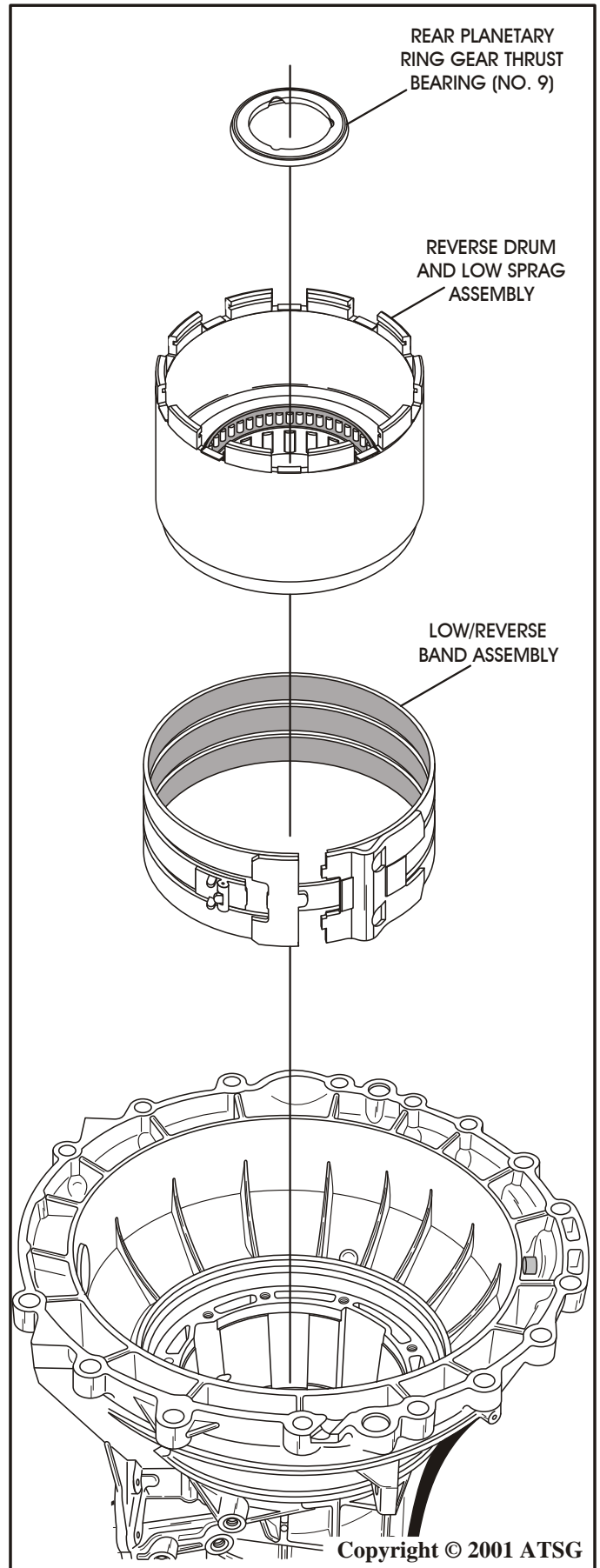

Figure 53

COMPONENT REBUILD SECTION

OIL PUMP ASSEMBLY

1. Disassemble the oil pump assembly using the illustrations in Figure 54 as a guide.
2. Remove and discard the converter seal and all sealing rings (See Figure 54).
3. Inspect all oil pump parts thoroughly for any wear and/or damage.
4. Clean all oil pump and cover parts thoroughly and dry with compressed air

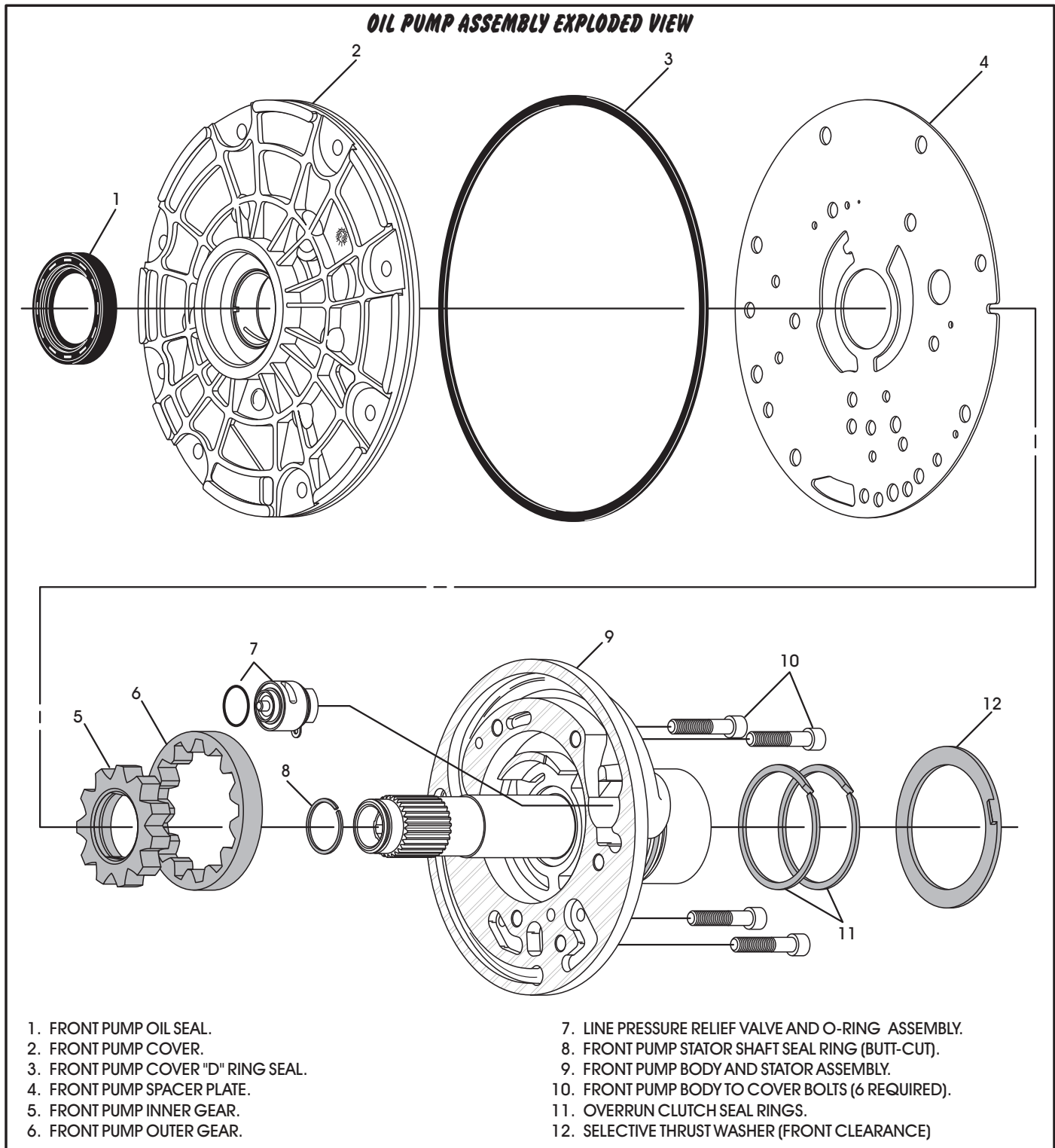

Figure 54

OIL PUMP ASSEMBLY (Cont'd)

5. Install selective thrust washer that came with the unit and retain with Trans-Jel®, as shown in Figure 55.
 6. Install the two overrun clutch seal rings into their grooves and insure that the scarf cuts are assembled properly (See Figure 55).
 7. Install a new "O" ring on the inside diameter of the inner pump gear and ensure that it is fully seated in the groove (See Figure 57). Lube with a small amount of Trans-Jel®.
 8. Dip the pump gears into transmission fluid and install them with the "Dots" facing down, as shown in Figure 57.
- Caution: The pump gears must be installed with the "Dots" facing down (See Figure 56).**
9. Install a new "Butt-Cut" seal ring in the groove in the stator shaft, as shown in Figure 57.
 10. Install the line pressure relief valve and "O-ring" into the cavity in the pump, as shown in Figure 57.

Continued on Page 44

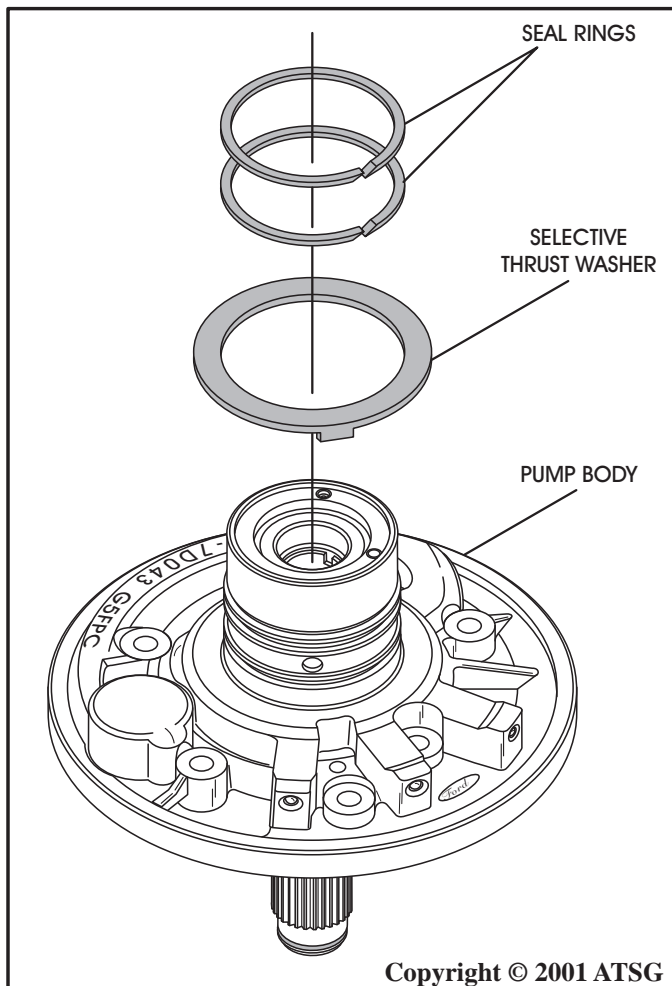

Figure 55

Copyright © 2001 ATSG

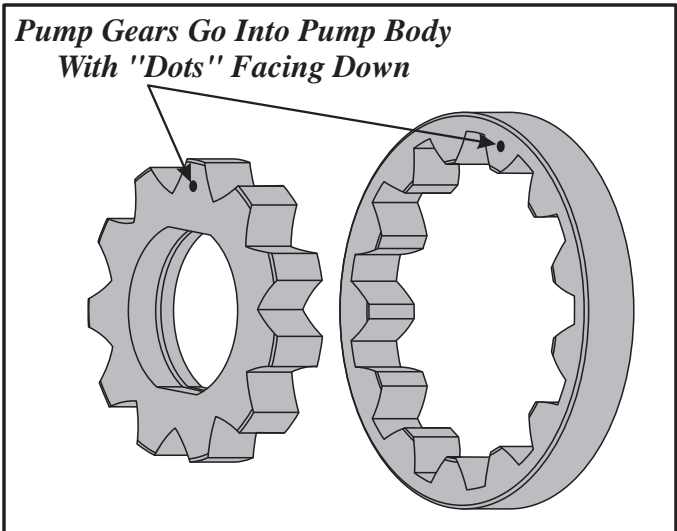

Figure 56

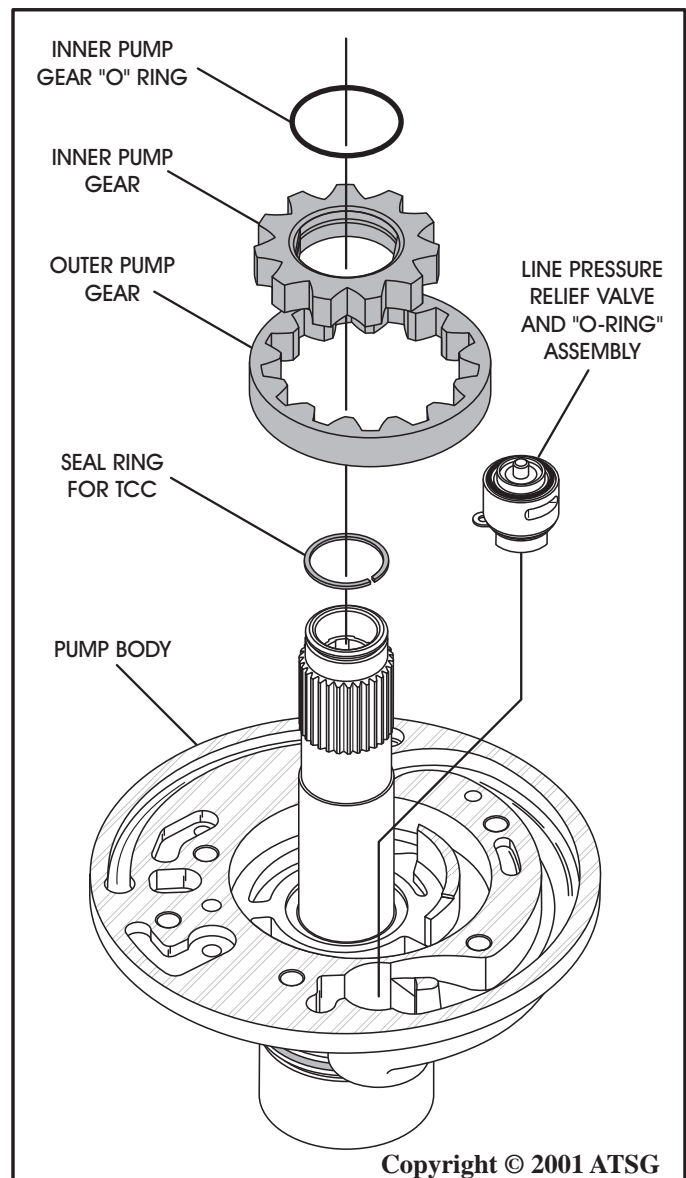

Figure 57

Copyright © 2001 ATSG

OIL PUMP ASSEMBLY (Cont'd)

11. Install a new converter seal into the oil pump cover using the proper seal driver, as shown in Figure 58.
12. Install a new "D" ring seal into outer groove of the oil pump cover, as shown in Figure 58.
13. Lubricate both seals and bushing with a small amount of Trans-Jel®.
14. Place pump body and stator shaft assembly on bench with shaft facing up (See Figure 59).
15. Install oil pump spacer plate and pump cover onto pump body, as shown in Figure 59.

Continued on Page 45

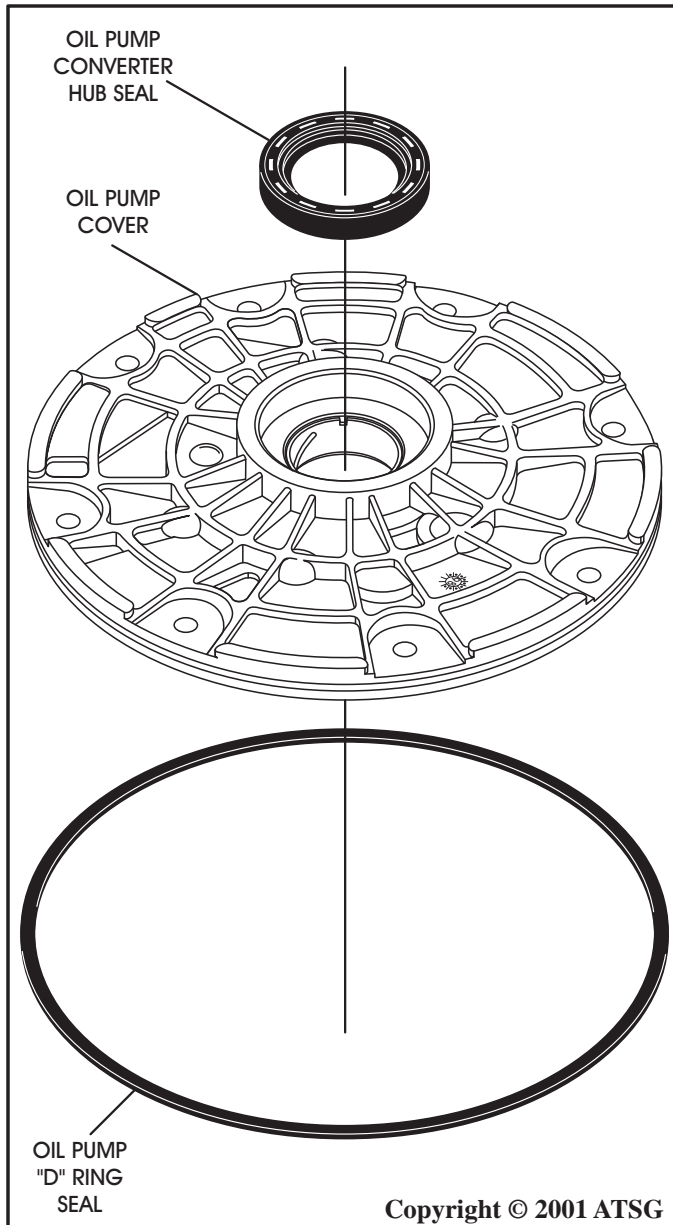

Figure 58

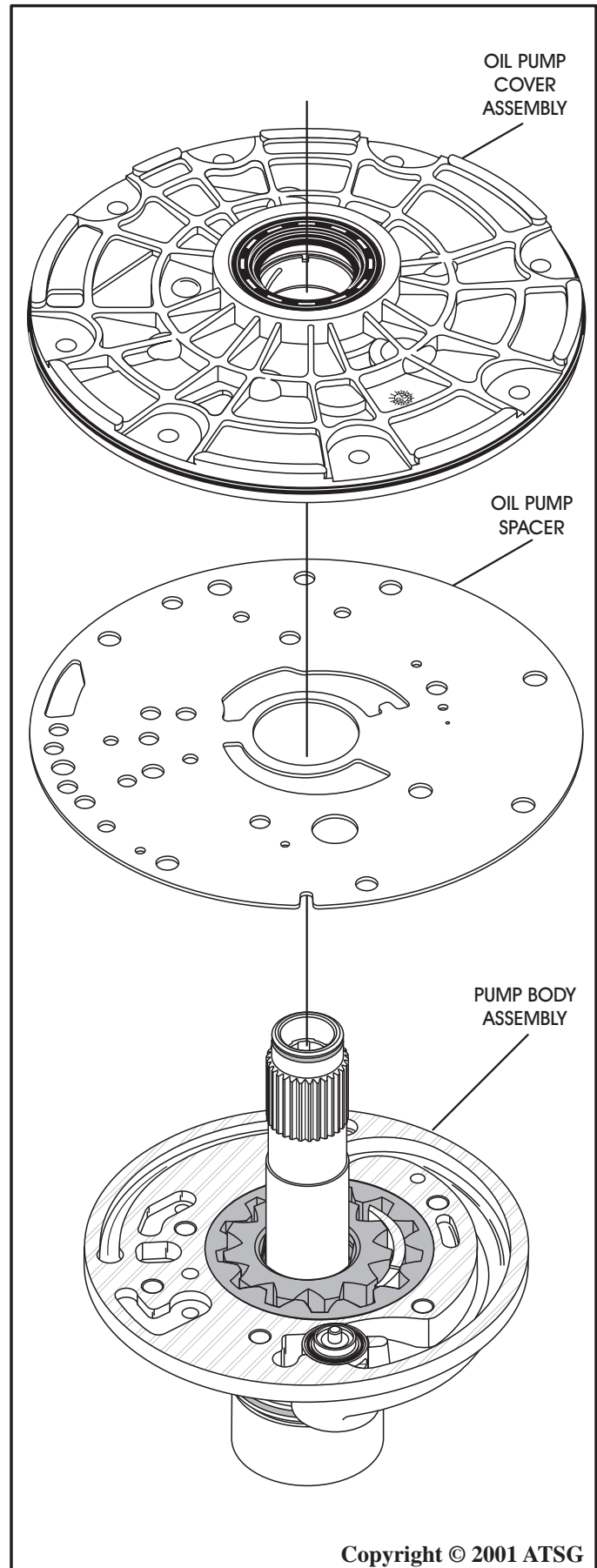

Figure 59

OIL PUMP ASSEMBLY (Cont'd)

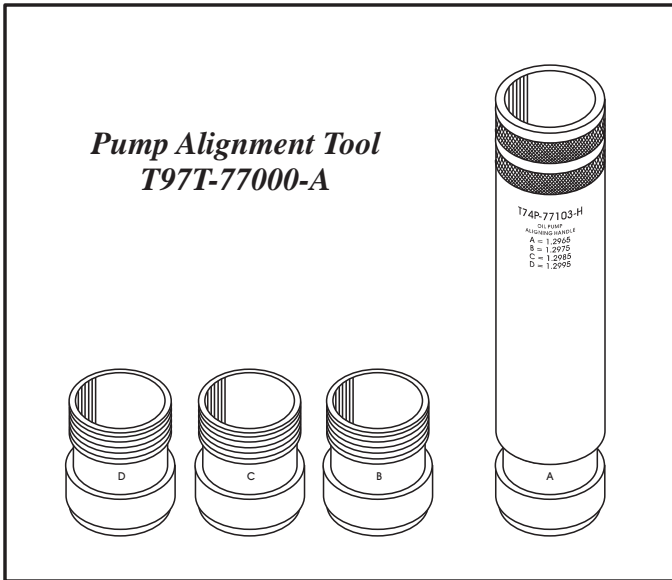

Figure 60

16. Install the appropriate size sleeve into handle of Pump Alignment Tool T97T-77000-A, shown in Figure 60, and install into pump.
17. Turn the assembly over and install the six bolts that retain the body to the cover, as shown in Figure 61.
18. With the alignment tool in place torque all six bolts in a star pattern to 18 ft.lb. as shown in Figure 62.
19. Remove the alignment tool and ensure that the pump gears will turn after they are torqued, as shown in Figure 62.
20. Set completed pump assembly aside for the final assembly process.

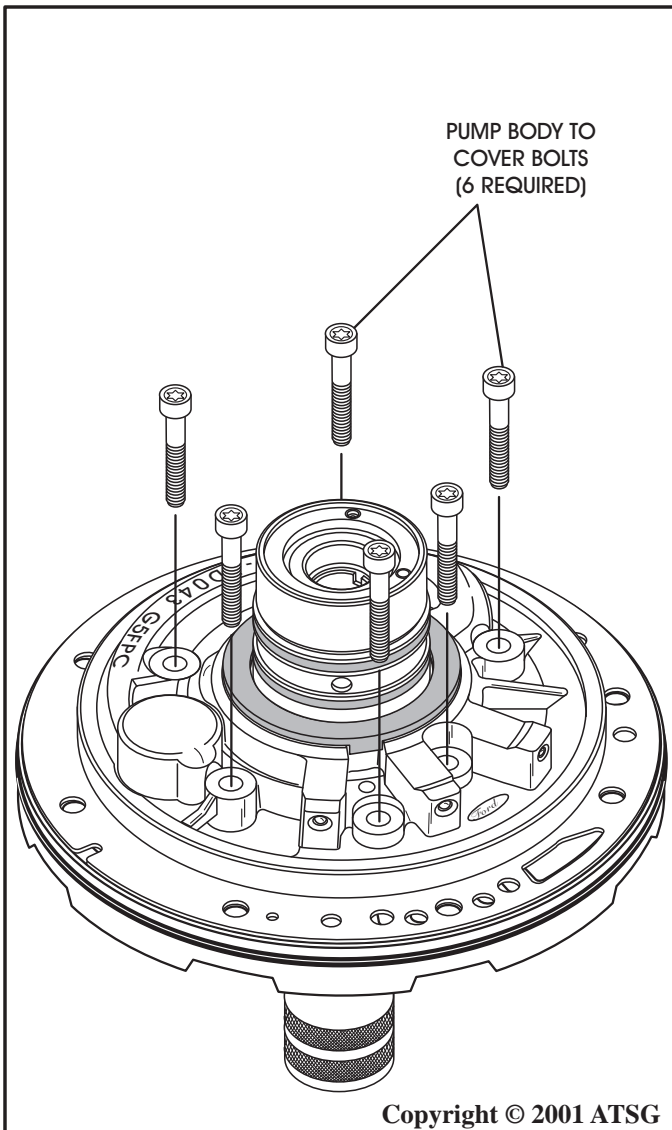

Figure 61

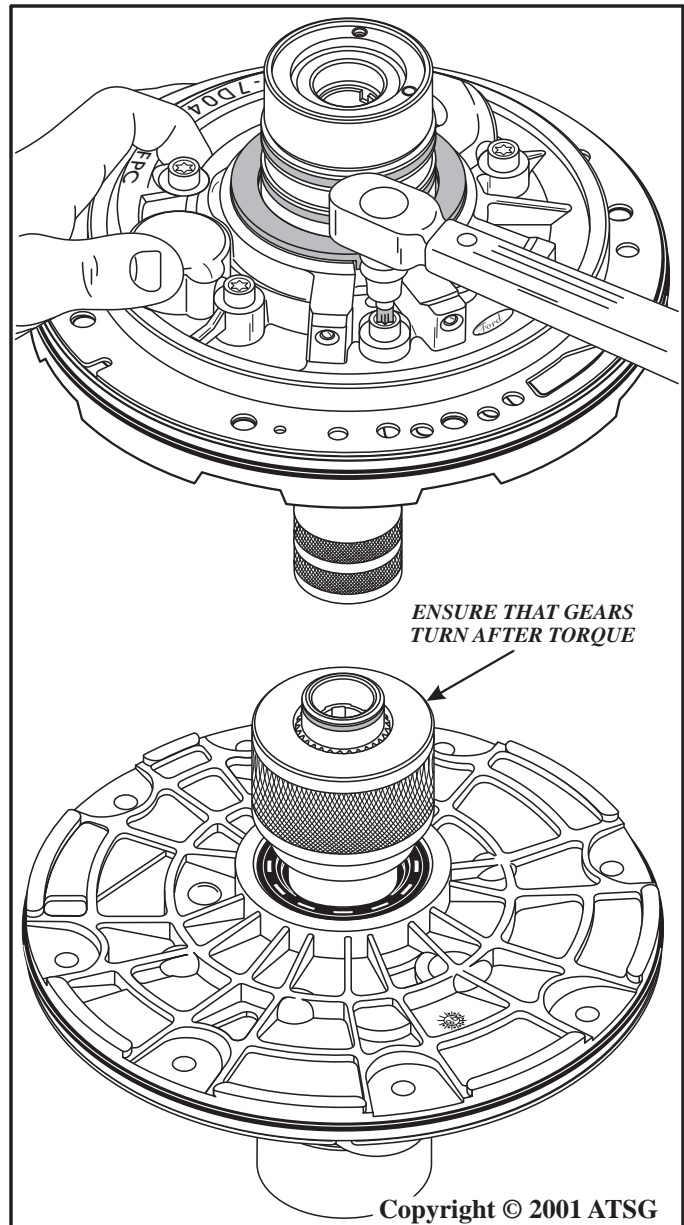

Figure 62

COAST CLUTCH ASSEMBLY

1. Disassemble the coast clutch assembly using the illustrations in Figure 63 as a guide.
2. Remove and discard the coast clutch lip seals, as shown in Figure 63.
3. Inspect all coast clutch parts thoroughly for any wear and/or damage.
4. Clean all coast clutch parts thoroughly and dry with compressed air.

Continued on Page 47

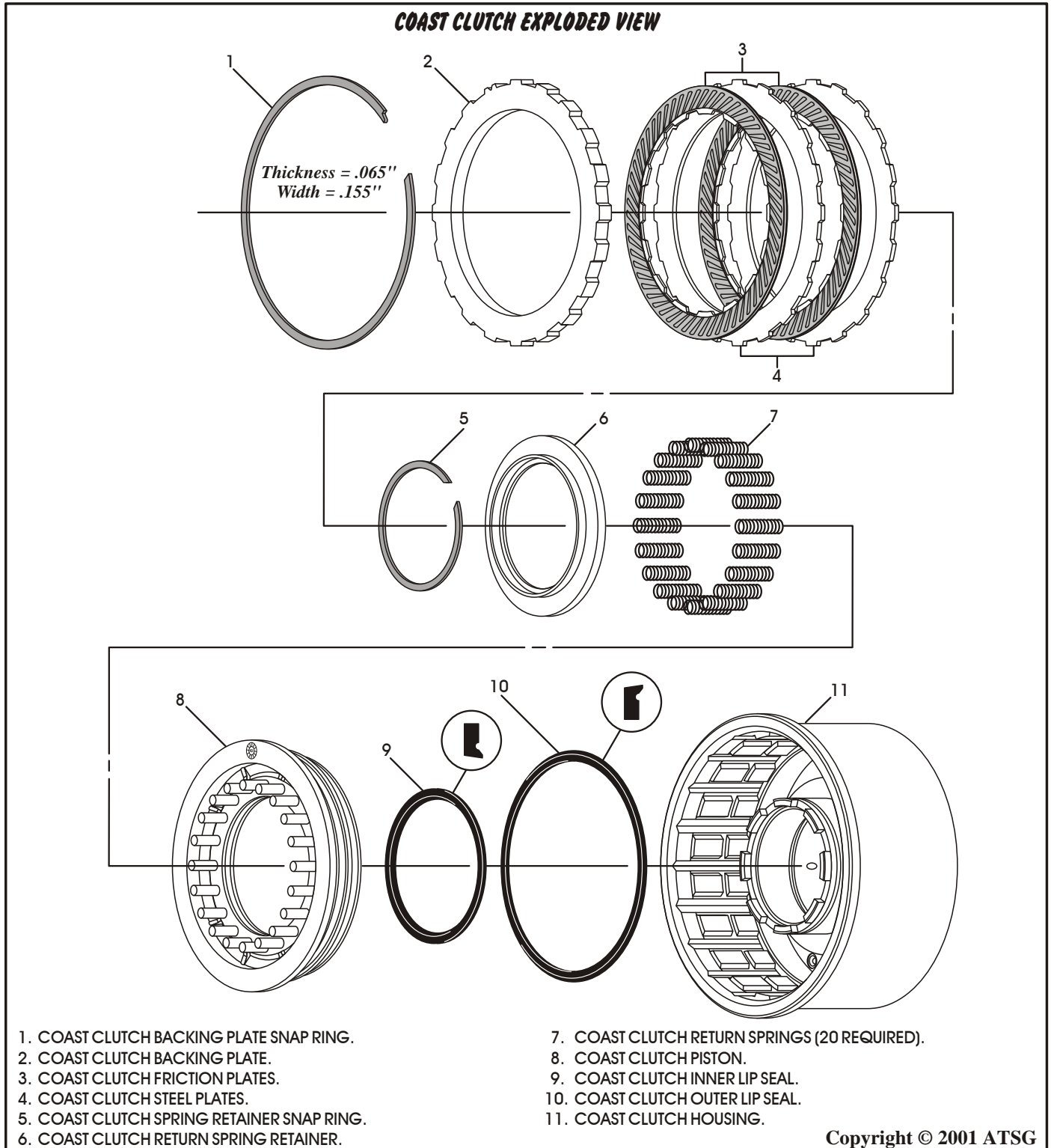

Figure 63

COAST CLUTCH ASSEMBLY (Cont'd)

5. Install a new inner lip seal into the groove in the coast clutch piston, with the lip facing down, as shown in Figure 64.
6. Install a new outer lip seal into the groove in the coast clutch piston, with the lip facing down, as shown in Figure 64.
7. Lubricate both inner and outer lip seals with a small amount of Trans-Jel®.
8. Lubricate both the inner and outer seal surfaces in coast clutch housing with a small amount of Trans-Jel®.
9. Install the completed coast clutch piston into the overrun clutch housing with twisting motion, as shown in Figure 65.

Continued on Page 48

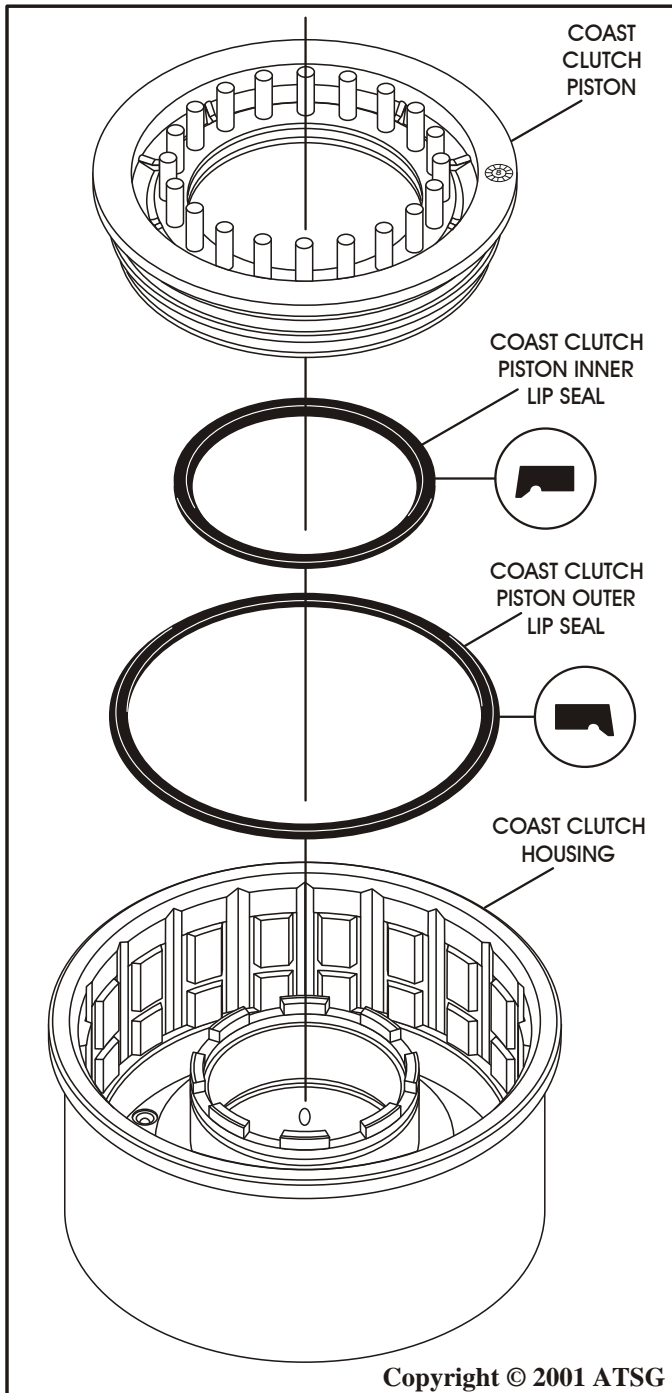

Figure 64

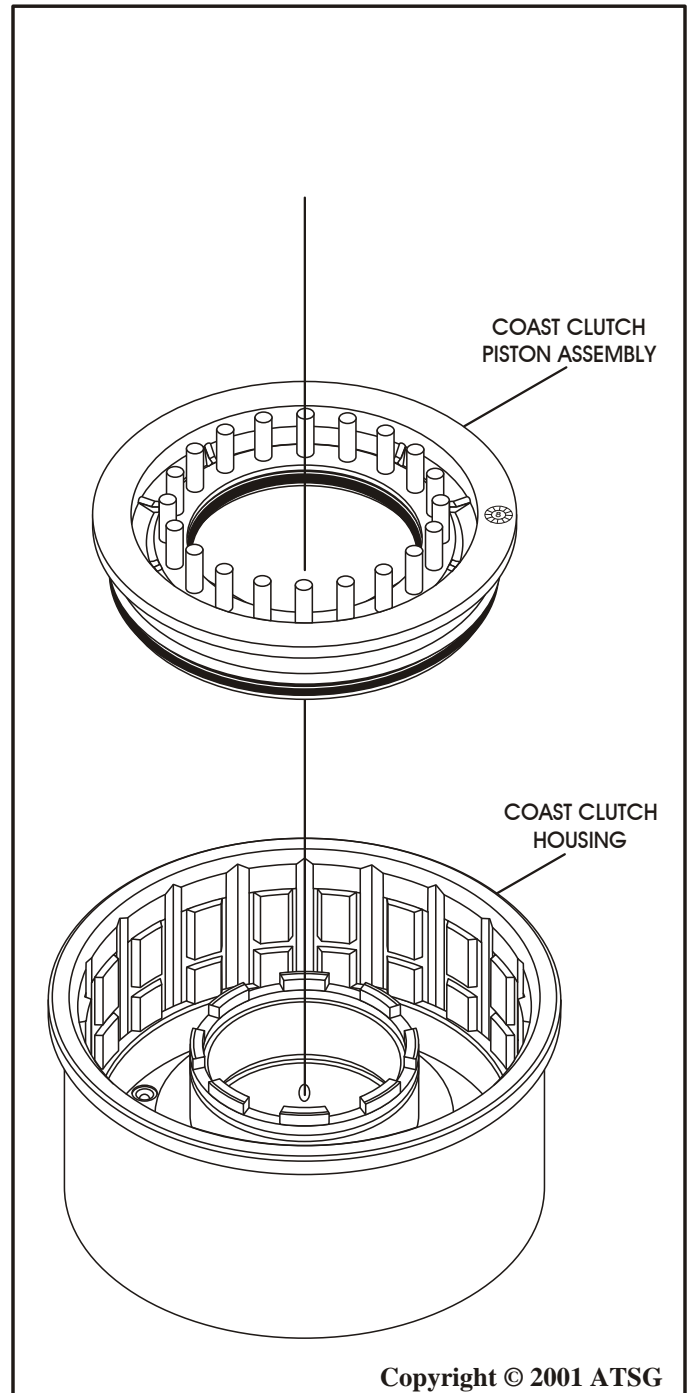

Figure 65

COAST CLUTCH ASSEMBLY (Cont'd)

10. Install the coast clutch piston return springs on the coast clutch piston, as shown in Figure 66.
11. Install the coast clutch return spring retainer on top of return springs, as shown in Figure 66.
12. Carefully compress the retainer and the return springs and install the retaining snap ring, as shown in Figure 66.
13. Remove the spring compressor and ensure that everything is fully seated.
14. Install the friction and steel coast clutch plates into the coast clutch drum, beginning with a steel plate and alternating with a friction plate, until you have installed two of each, as shown in Figure 67.

CAUTION: *Coast Clutch friction plates are directional and must be installed with the grooves facing clockwise, as shown in Figures 67 and 68. Friction plates should be soaked in Mercon V® for at least 30 minutes before installation.*

15. Install the coast clutch backing plate, as shown in Figure 67.
16. Install the coast clutch backing plate snap ring, as shown in Figure 67 and ensure that it is fully seated in the groove (See Figure 67).
17. Install dial indicator on top of backing plate, as shown in Figure 69, and check the coast clutch clearance. Should be 1.3-2.0mm (.051"-.079"), as shown in Figure 69.
18. Change the selective backing plate snap ring as necessary, using the chart in Figure 69, to get the proper clutch clearance.
19. Set the completed coast clutch housing aside for the final assembly process.

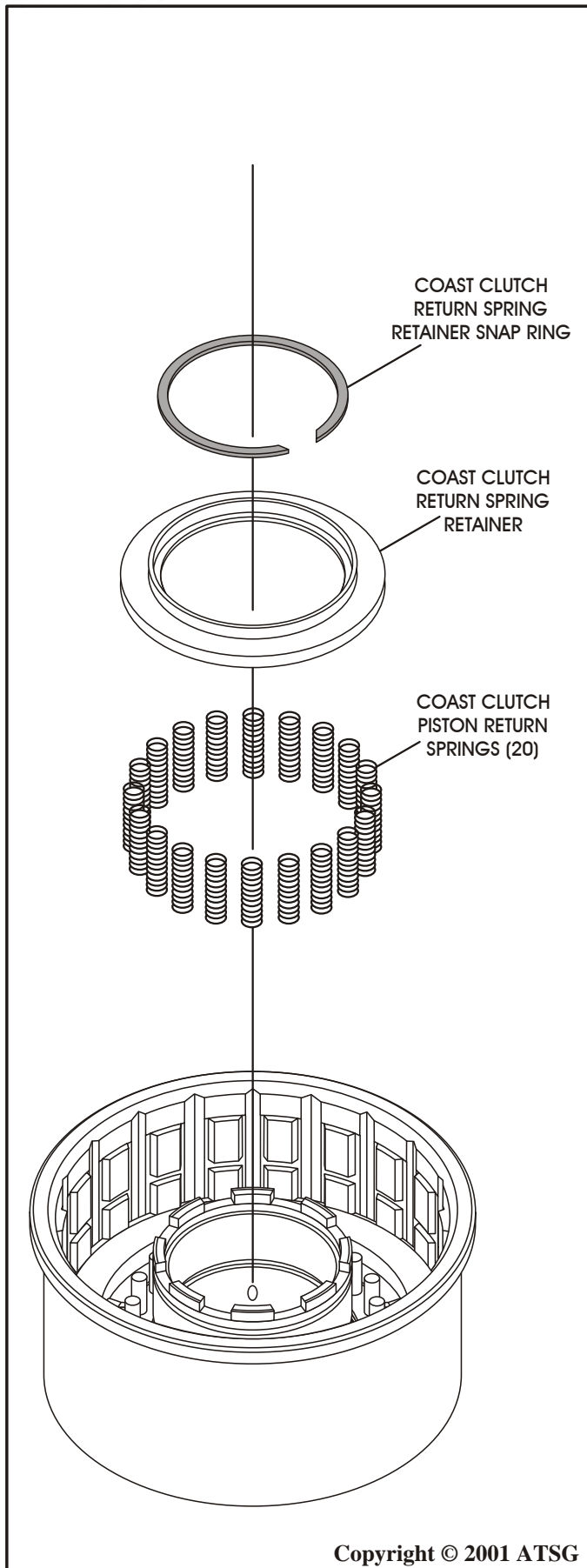

Copyright © 2001 ATSG

Figure 66

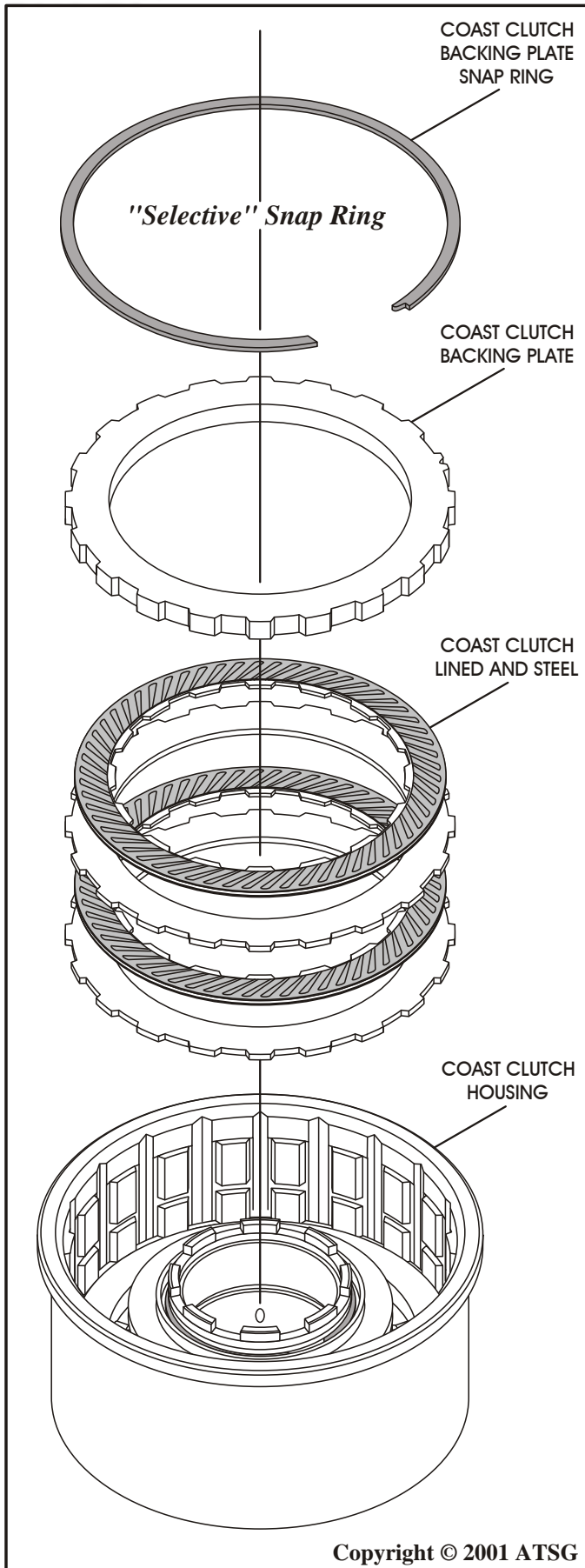

Figure 67

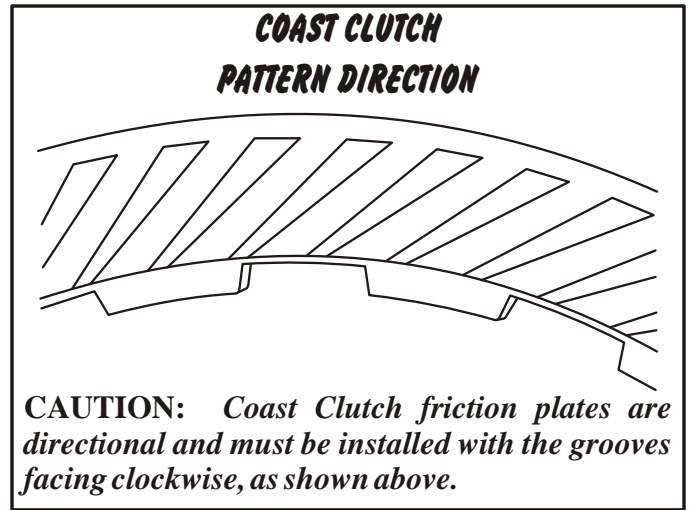

Figure 68

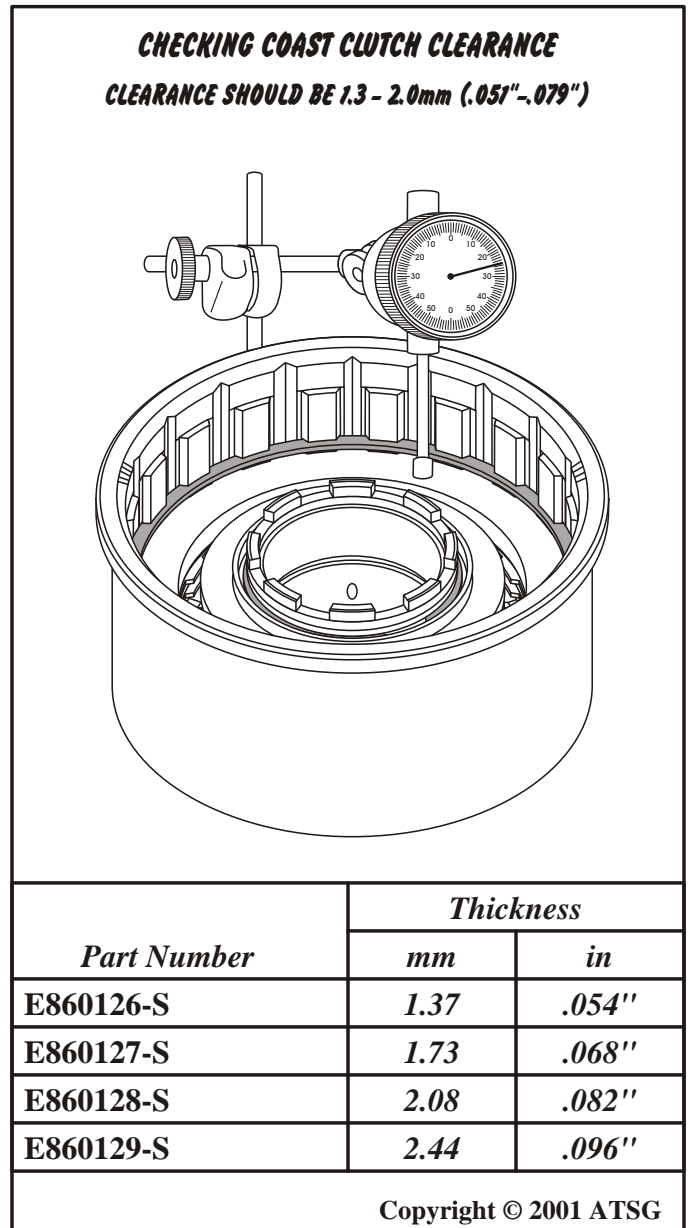

Figure 69

OVERDRIVE CARRIER AND SPRAG ASSEMBLY

1. Disassemble the overdrive carrier from center shaft using Figure 70 as a guide.
2. Inspect all of the overdrive carrier parts shown in Figure 70 for any wear and/or damage.
3. Clean all overdrive carrier parts thoroughly and dry with compressed air.
4. Install the overdrive sprag assembly into the overdrive center shaft, in the direction shown in Figure 71, until fully seated.
5. Install thrust bearing onto overdrive carrier, as shown in Figure 72, and retain with a small amount of Trans-Jel®.
6. Install completed overdrive center shaft onto the overdrive carrier by rotating shaft counter clockwise as you install (See Figure 72).

Continued on Page 52

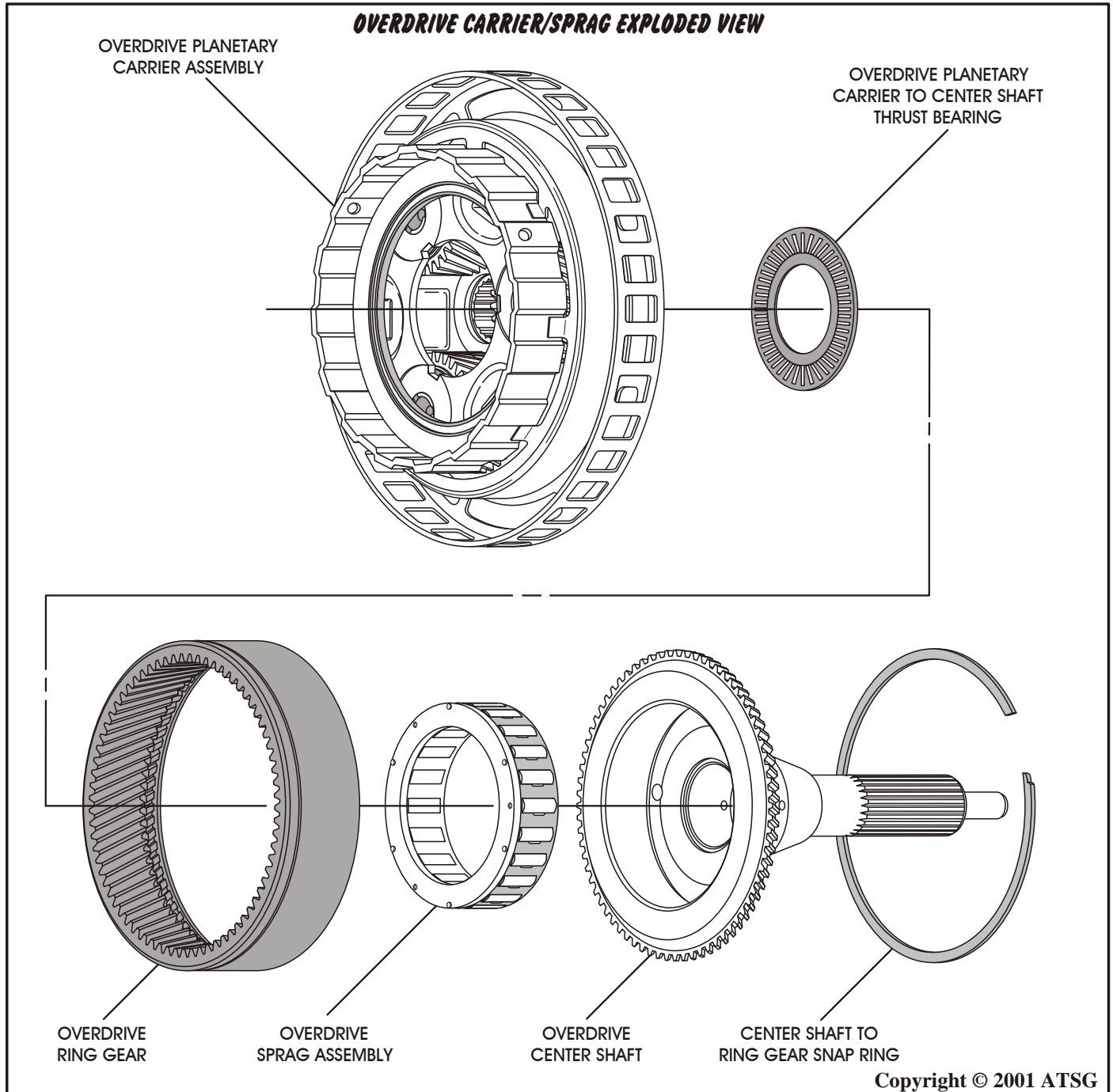

Figure 70

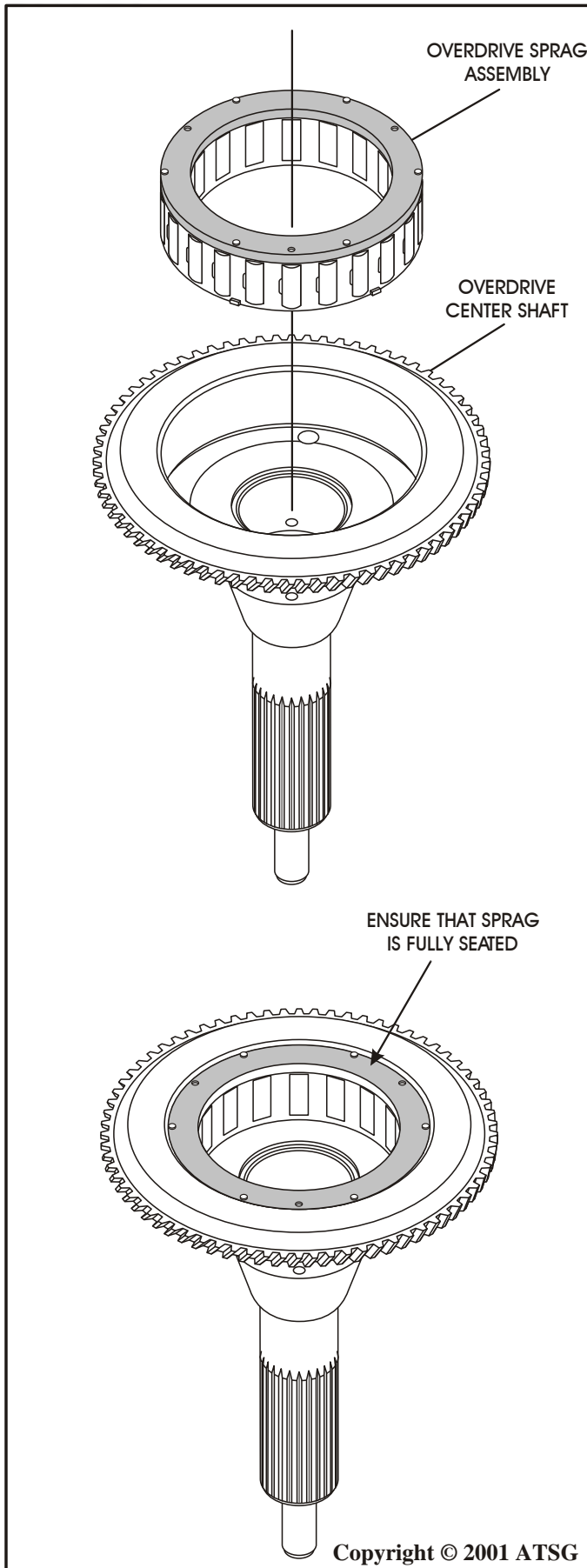

Figure 71

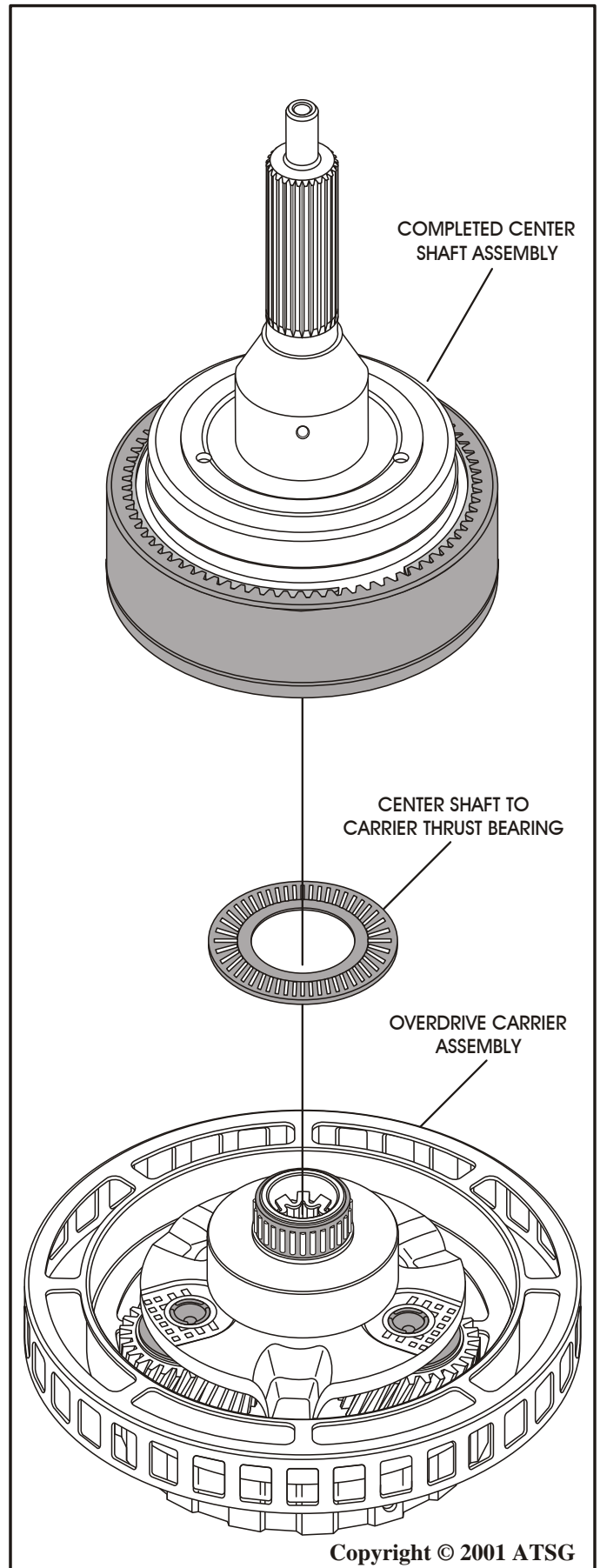

Figure 72

OVERDRIVE CARRIER AND SPRAG ASSEMBLY (Cont'd)

7. Verify proper overdrive sprag rotation, using Figures 73 or 74, and then set the overdrive planetary carrier aside for final assembly.

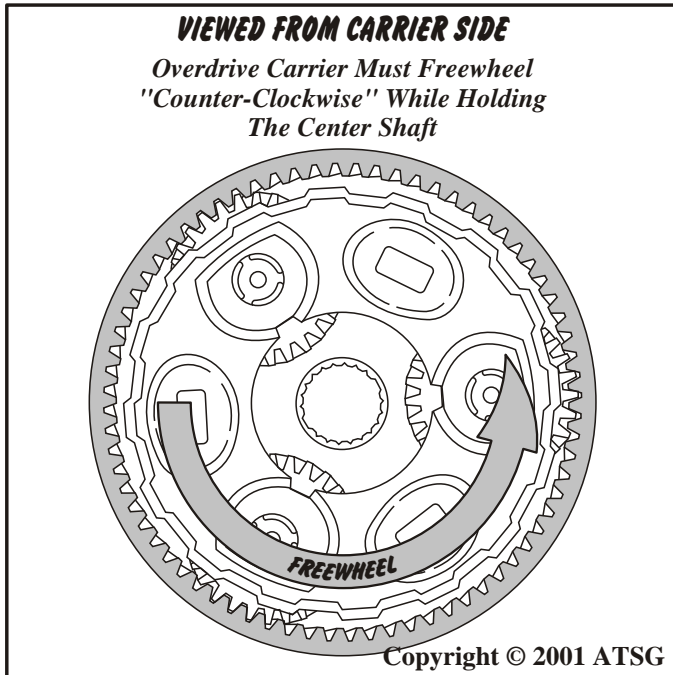

Figure 73

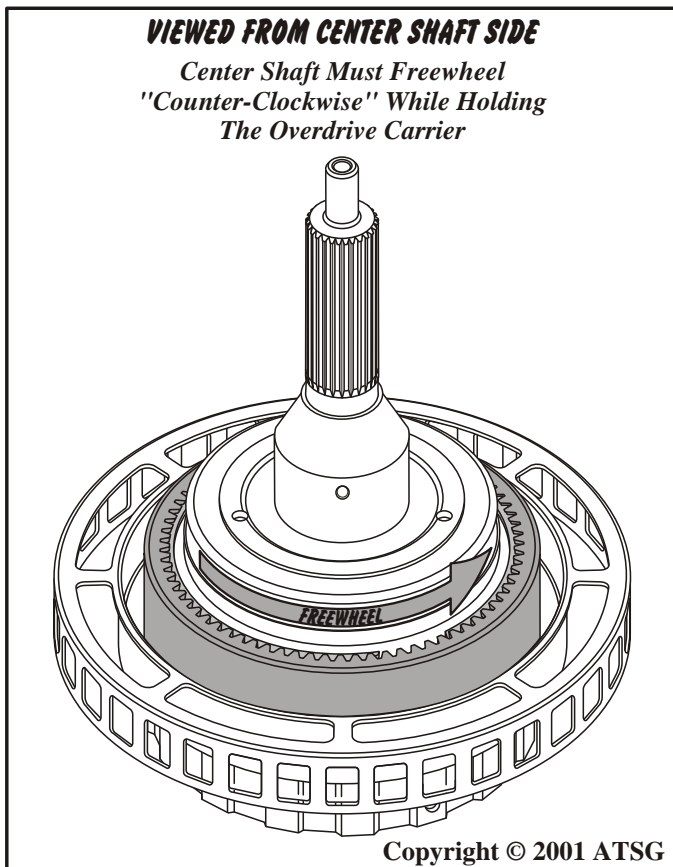

Figure 74

DIRECT CLUTCH ASSEMBLY

1. Disassemble the direct clutch assembly using the illustrations in Figure 76 as a guide.
2. Remove and discard the direct clutch lip seals, as shown in Figure 76.
3. Inspect all direct clutch parts thoroughly for any wear and/or damage.
4. Clean all direct clutch parts thoroughly and dry with compressed air.
5. Install a new inner lip seal into the groove in the direct clutch piston, with the lip facing down, as shown in Figure 75.
6. Install a new outer lip seal into the groove in the direct clutch piston, with the lip facing down, as shown in Figure 75.
7. Lubricate both inner and outer lip seals with a small amount of Trans-Jel®.

Continued on Page 54

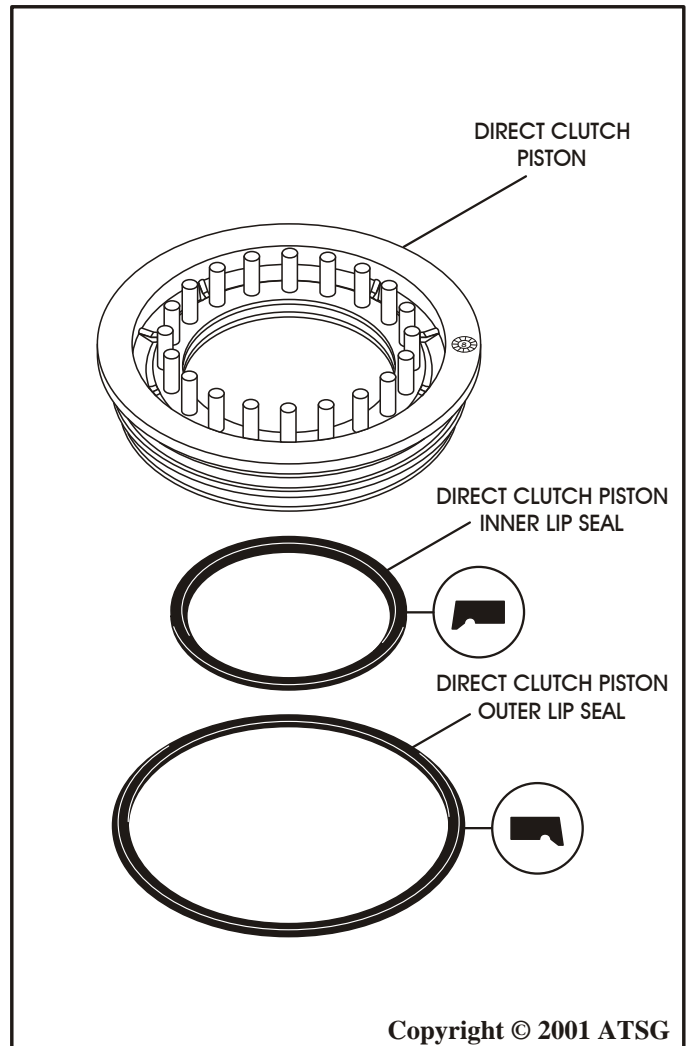
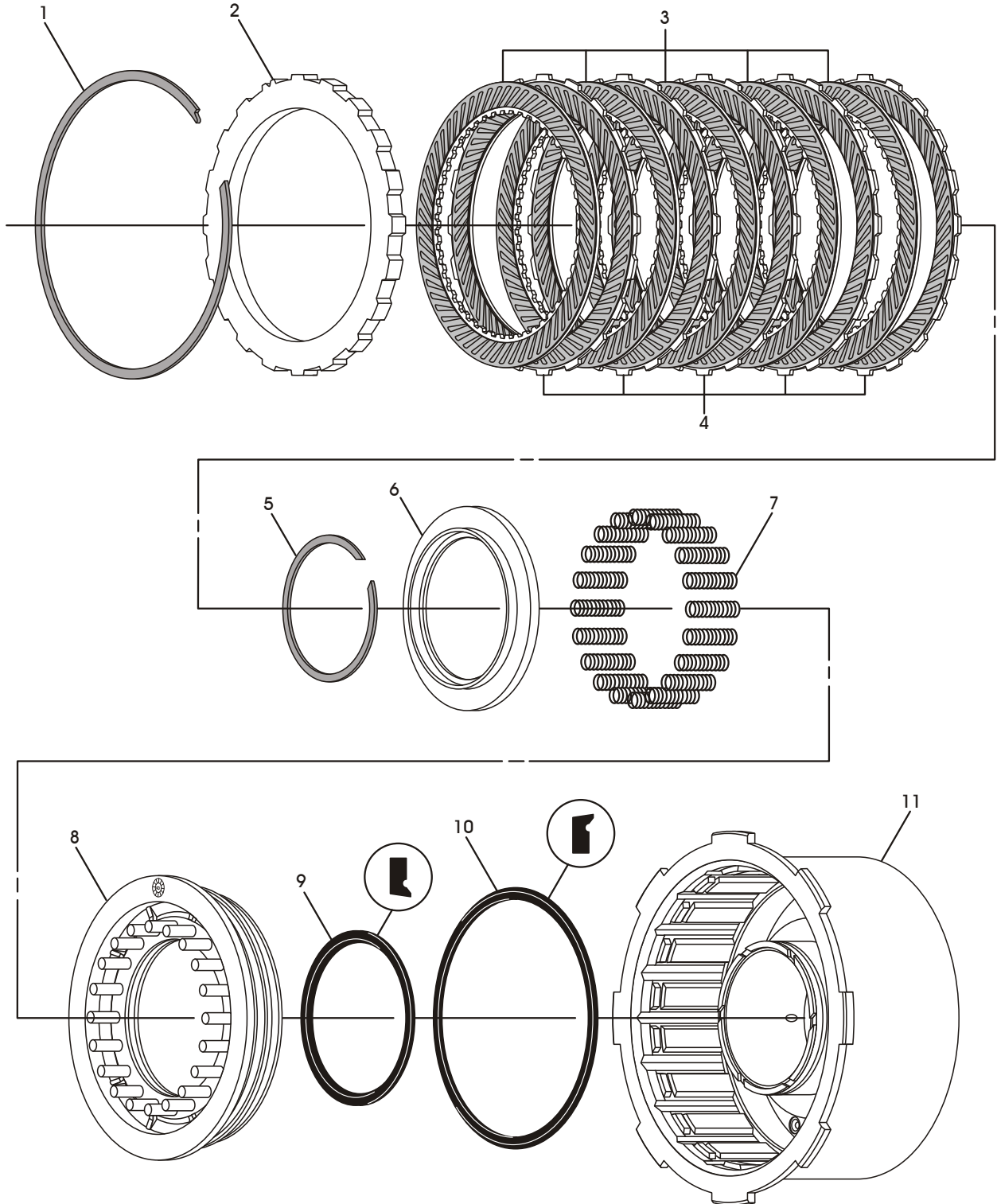

Figure 75

DIRECT CLUTCH EXPLODED VIEW



- 1. DIRECT CLUTCH BACKING PLATE "SELECTIVE" SNAP RING.
- 2. DIRECT CLUTCH BACKING PLATE.
- 3. DIRECT CLUTCH "SINGLE SIDED" INSIDE SPLINE PLATES.
- 4. DIRECT CLUTCH "SINGLE SIDED" OUTSIDE SPLINE PLATES.
- 5. DIRECT CLUTCH SPRING RETAINER SNAP RING.
- 6. DIRECT CLUTCH RETURN SPRING RETAINER.

- 7. DIRECT CLUTCH RETURN SPRINGS (20 REQUIRED).
- 8. DIRECT CLUTCH PISTON.
- 9. DIRECT CLUTCH INNER LIP SEAL.
- 10. DIRECT CLUTCH OUTER LIP SEAL.
- 11. DIRECT CLUTCH HOUSING.

Copyright © 2001 ATSG

Figure 76

DIRECT CLUTCH ASSEMBLY (Cont'd)

8. Lubricate both the inner and outer seal surfaces in direct clutch housing with a small amount of Trans-Jel®.
9. Install the completed direct clutch piston into the direct clutch housing with twisting motion, as shown in Figure 77.
10. Install the direct clutch piston return springs on the direct clutch piston, as shown in Figure 78.
11. Install the direct clutch return spring retainer on top of return springs, as shown in Figure 78.
12. Carefully compress the retainer and the return springs and install the retaining snap ring, as shown in Figure 78.
13. Remove the spring compressor and ensure that everything is fully seated.
14. Install the direct clutches beginning with an outside spline plate and alternating with inside spline plates, until you have installed 5 of each, as shown in Figure 79.

CAUTION: *Direct Clutch friction plates are directional and must be installed with the internal tooth plate grooves facing clockwise, and the external tooth plates grooves facing counterclockwise, as shown in Figure 80.*

Caution: *Friction plates should be soaked in Mercon V® 30 minutes before installing.*

15. Install the direct clutch backing plate, as shown in Figure 79.
16. Install the direct clutch backing plate snap ring, as shown in Figure 79 and ensure that it is fully seated in the groove (See Figure 79).
17. Install dial indicator on top of backing plate, as shown in Figure 81, and check the direct clutch clearance. Should be 1.3-2.0mm (.051"-.079"), as shown in Figure 81.
18. Change the selective backing plate snap ring as necessary, using the chart in Figure 81, to get the proper direct clutch clearance.
19. Set the completed direct clutch housing aside for the final assembly process.

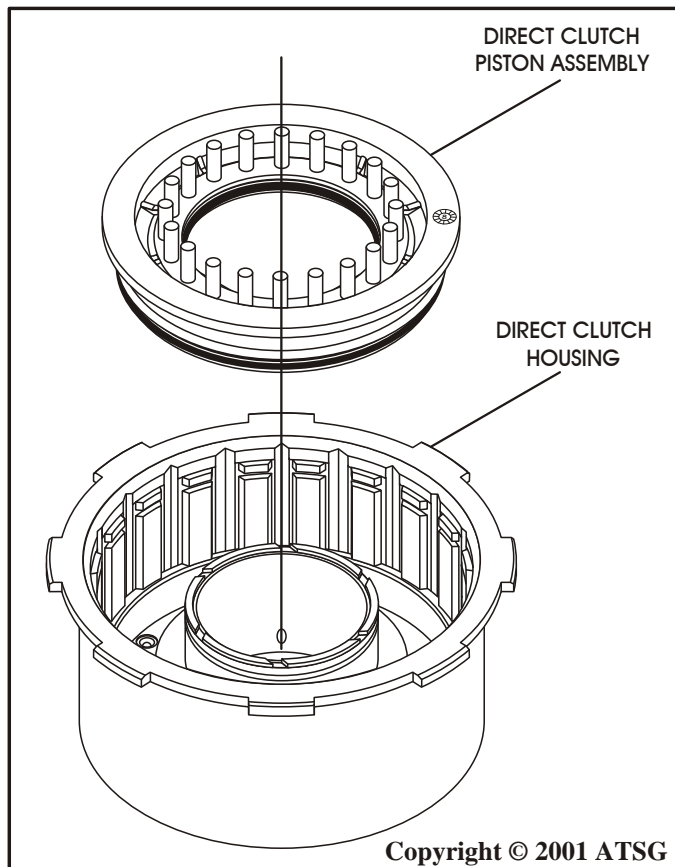

Figure 77

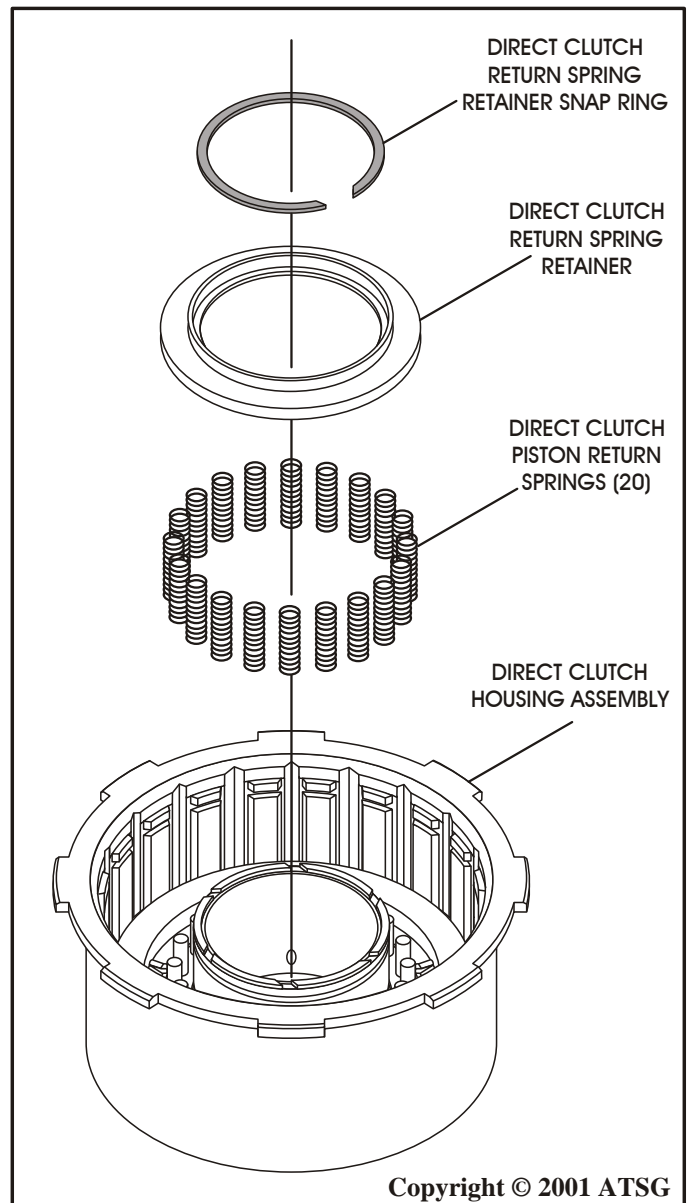

Figure 78

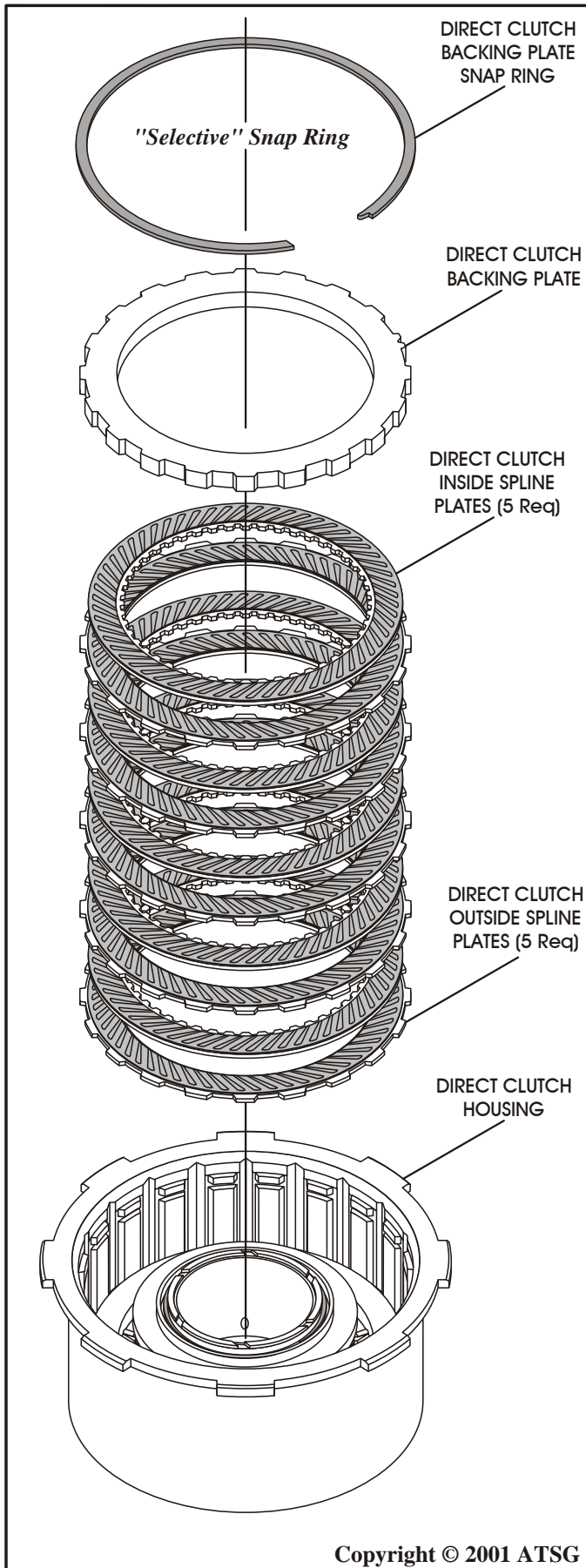

Figure 79

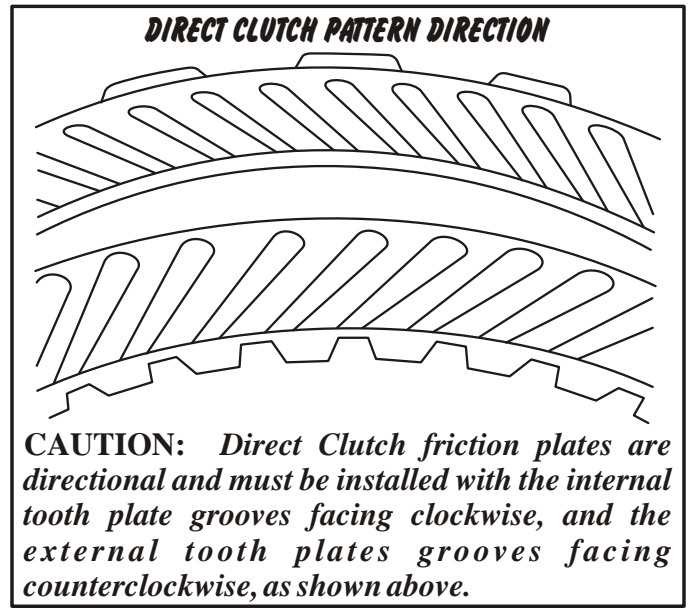

Figure 80

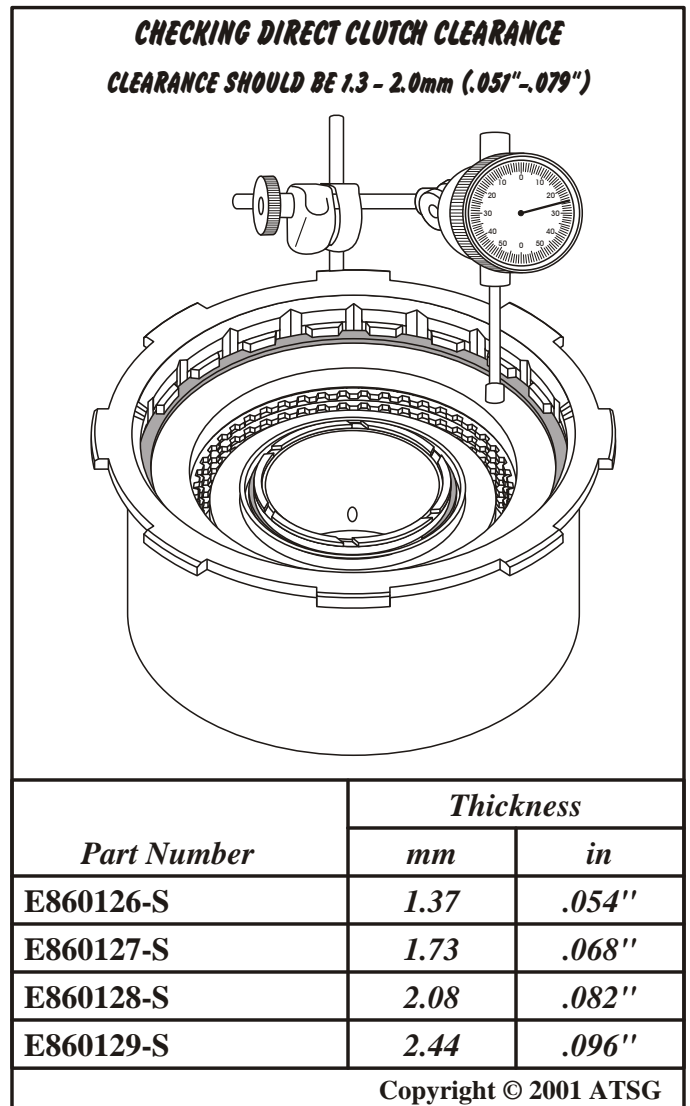
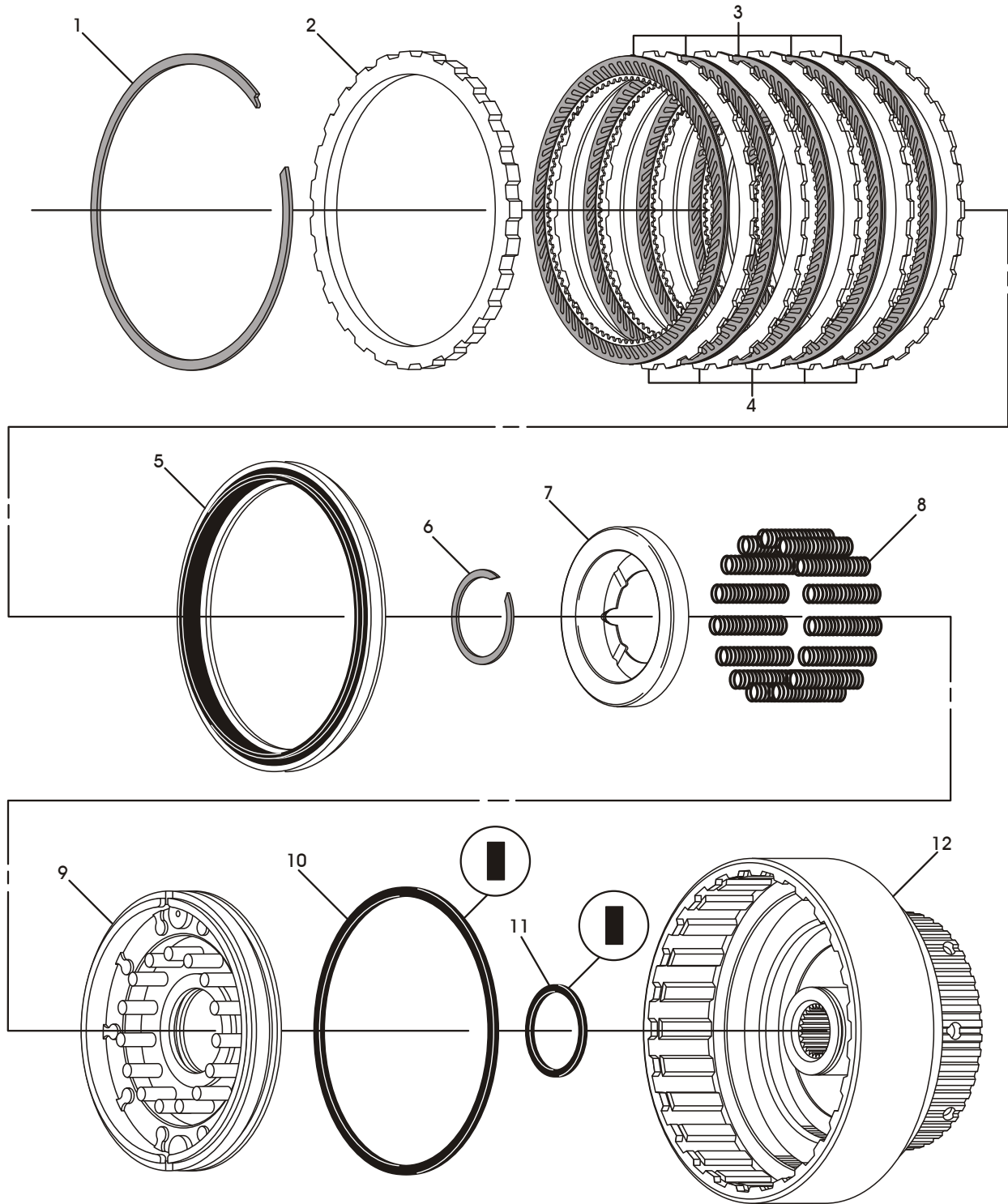

Figure 81

FORWARD CLUTCH ASSEMBLY EXPLODED VIEW



1. FORWARD CLUTCH BACKING PLATE "SELECTIVE" SNAP RING.
2. FORWARD CLUTCH BACKING PLATE.
3. FORWARD CLUTCH FRICTION PLATES.
4. FORWARD CLUTCH STEEL PLATES.
5. FORWARD CLUTCH CUSHION PLATE.
6. FORWARD CLUTCH RETURN SPRING RETAINER SNAP RING.

7. FORWARD CLUTCH PISTON RETURN SPRING RETAINER.
8. FORWARD CLUTCH PISTON RETURN SPRINGS (15 REQUIRED).
9. FORWARD CLUTCH PISTON.
10. FORWARD CLUTCH PISTON OUTER "D" RING SEAL.
11. FORWARD CLUTCH PISTON INNER "D" RING SEAL.
12. FORWARD CLUTCH HOUSING.

Copyright © 2001 ATSG

Figure 82

FORWARD CLUTCH ASSEMBLY

1. Disassemble the forward clutch assembly using the illustrations in Figure 82 as a guide.
2. Remove and discard the forward clutch piston "D" ring seals, as shown in Figure 82.
3. Inspect all forward clutch parts thoroughly for any wear and/or damage.
4. Clean all forward clutch parts thoroughly and dry with compressed air.
5. Install new sealing rings into their grooves on the forward clutch housing (See Figure 83).
6. Ensure that the sealing rings are seated and rotate freely in grooves (See Figure 84).
7. Install a new inner "D" ring seal into the groove in the forward clutch piston (See Figure 85)
8. Install a new outer "D" ring seal into the groove in the forward clutch piston (See Figure 85).
7. Lubricate both inner and outer "D" ring seals with a small amount of Trans-Jel®.

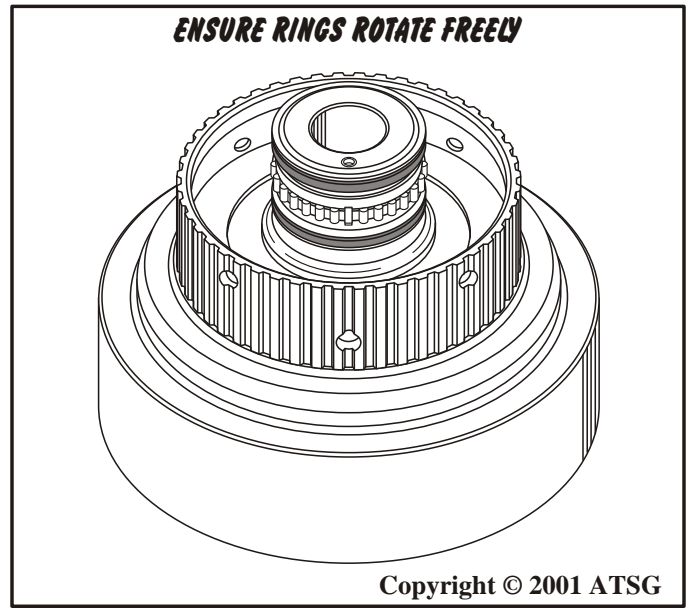

Figure 84

Continued on Page 58

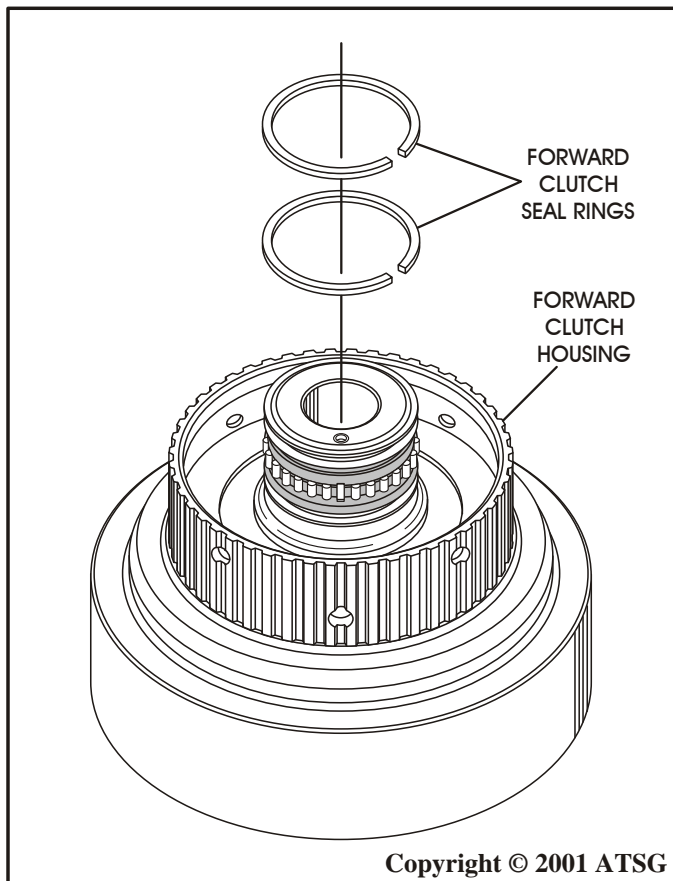

Figure 83

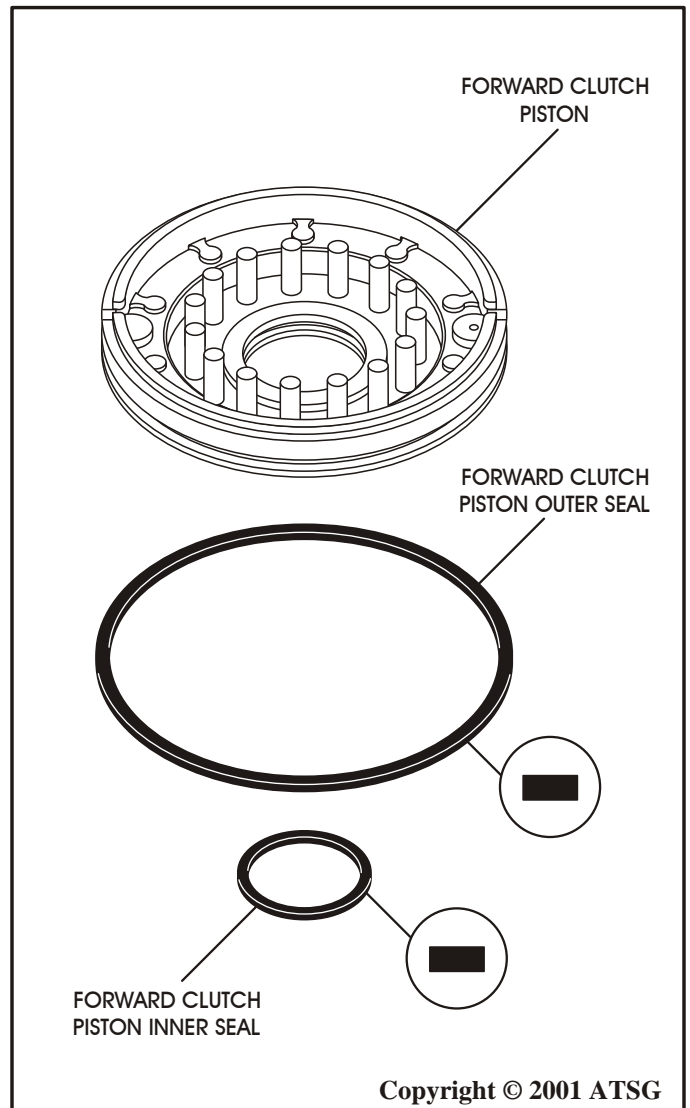

Figure 85

FORWARD CLUTCH ASSEMBLY (Cont'd)

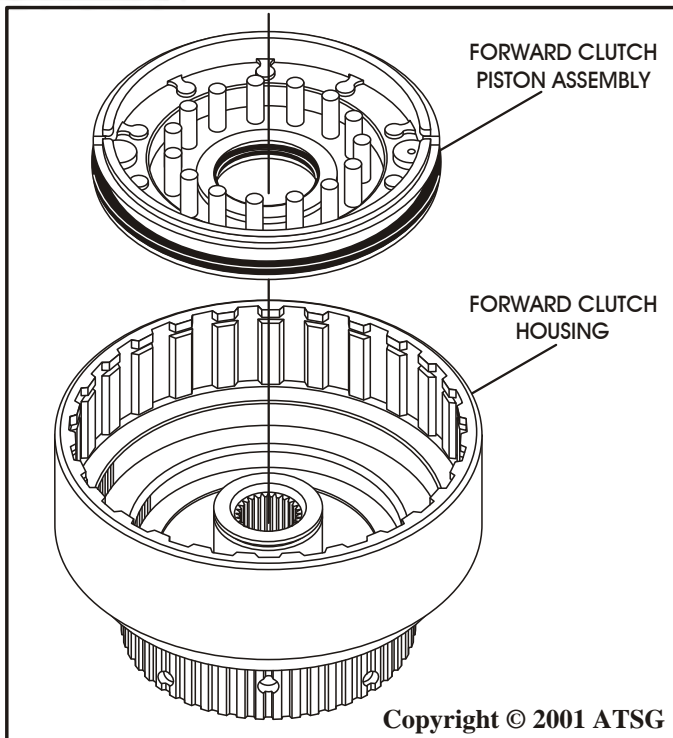

Figure 86

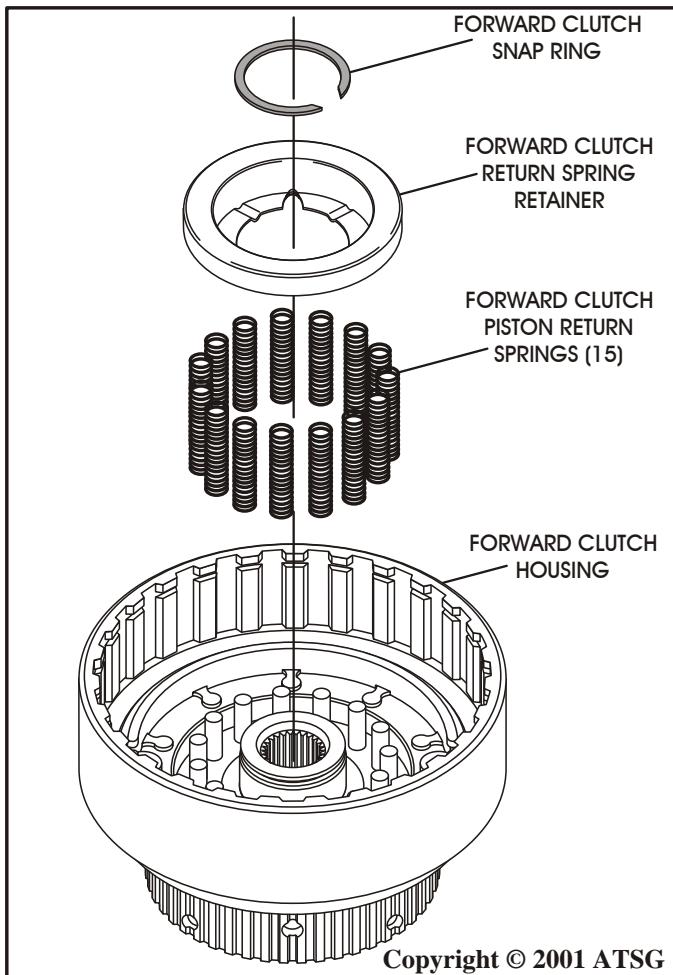

Figure 87

8. Lubricate both seal surfaces with small amount of Trans-Jel® and install the forward clutch piston with a twisting motion, using care so as not to damage the seals (See Figure 86).
9. Install the forward clutch piston return springs on the piston, as shown in Figure 87.
10. Install the spring retainer on top of the springs, as shown in Figure 87.
11. Compress the return springs and retainer and install the spring retainer snap ring, as shown in Figure 87.
12. Remove the spring compressor.
13. Install the forward clutch cushion plate on top of the piston, as shown in Figure 88.
14. Install the forward clutch plates beginning with a steel plate and alternating with friction plates, until you have installed 5 of each, as shown in Figure 88.

CAUTION: *Forward Clutch friction plates are directional and must be installed with the grooves facing counterclockwise, as shown in Figure 89. Friction plates should be soaked in Mercon V® for 30 minutes before installing.*

15. Install forward clutch backing plate, as shown in Figure 88.
16. Install forward clutch backing plate snap ring, as shown in Figure 88 and ensure that it is fully seated in the groove.
17. Install dial indicator on top of backing plate, as shown in Figure 90, and check the amount of forward clutch clearance. Clearance should be 1.3 - 2.0mm (.051" - .079") (See Figure 90).
18. Change the selective backing plate snap ring as necessary, using the chart in Figure 90, to get the proper forward clutch clearance.
19. Set the completed forward clutch housing aside for the final assembly process.

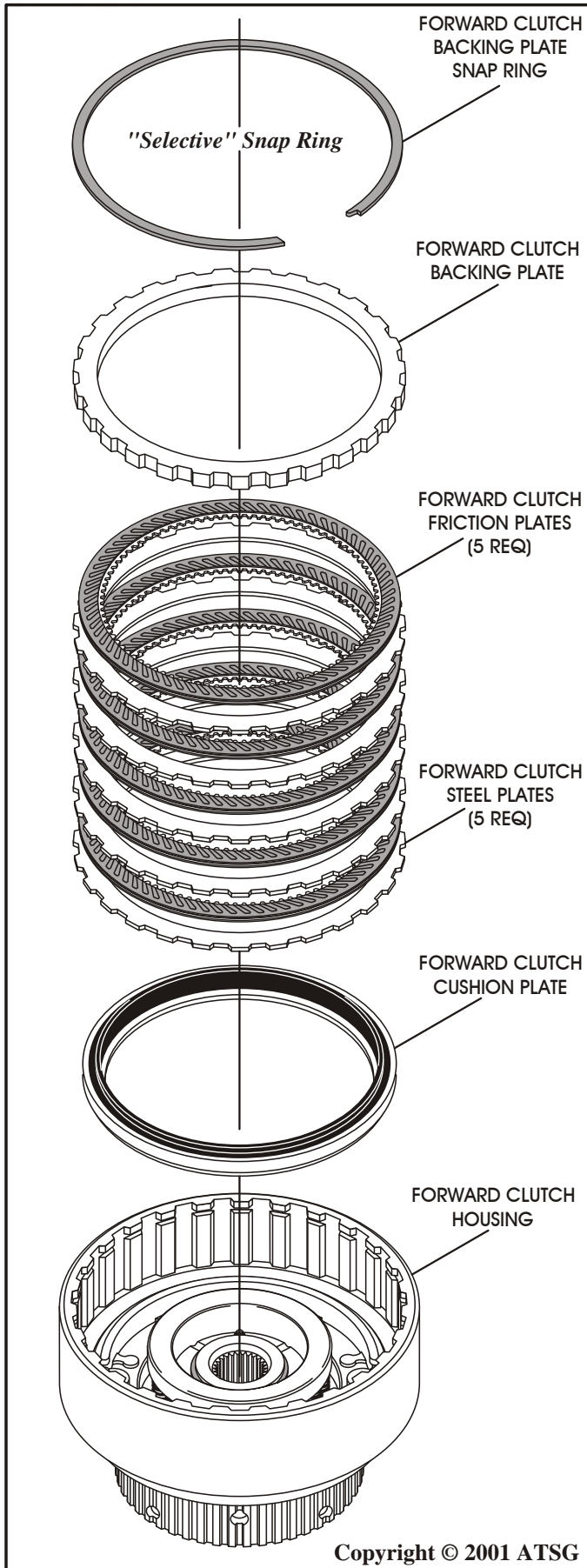

Figure 88

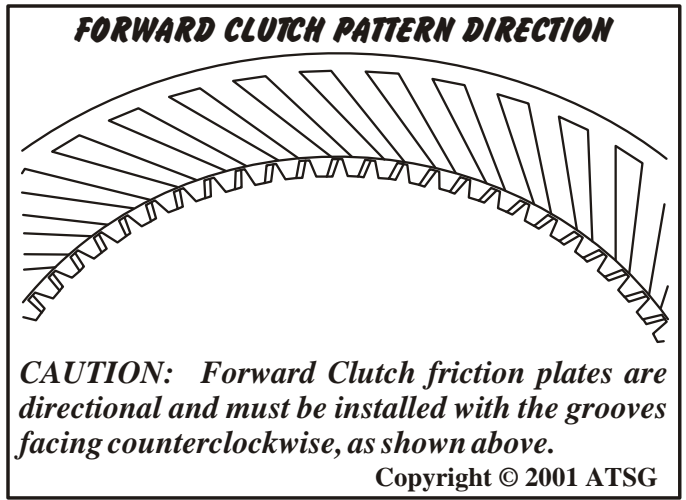

Figure 89

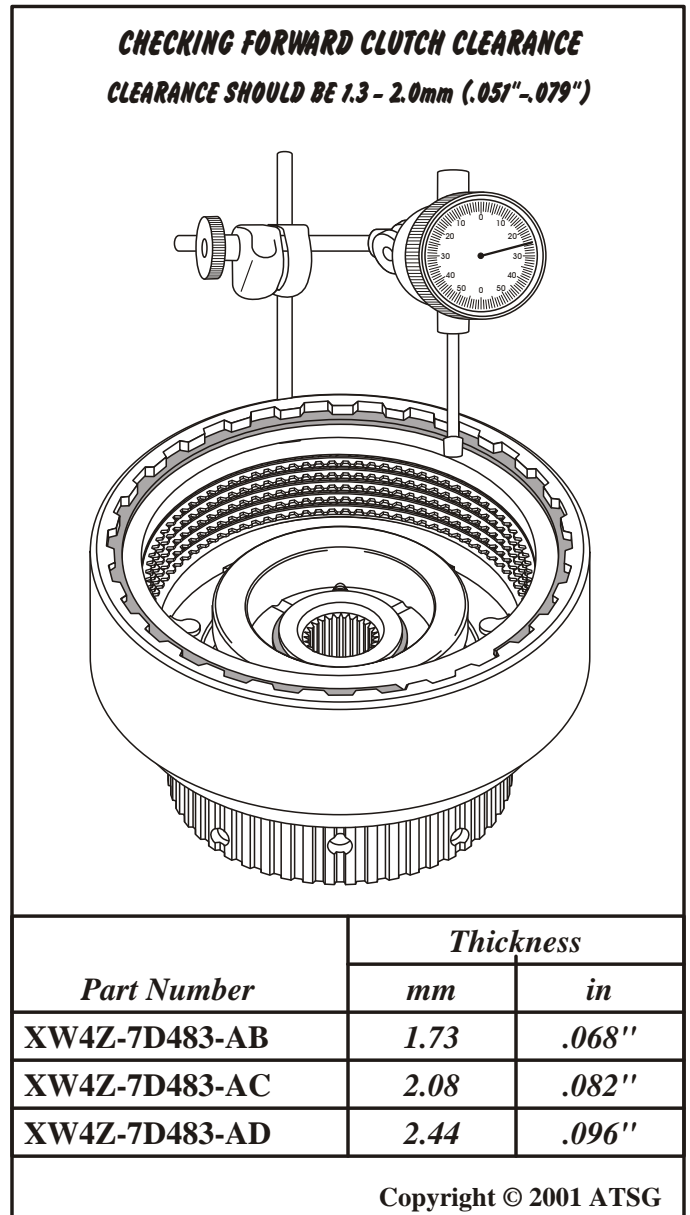

Figure 90

CHECK CENTER SUPPORT BEARING RACE FOR CRACKS

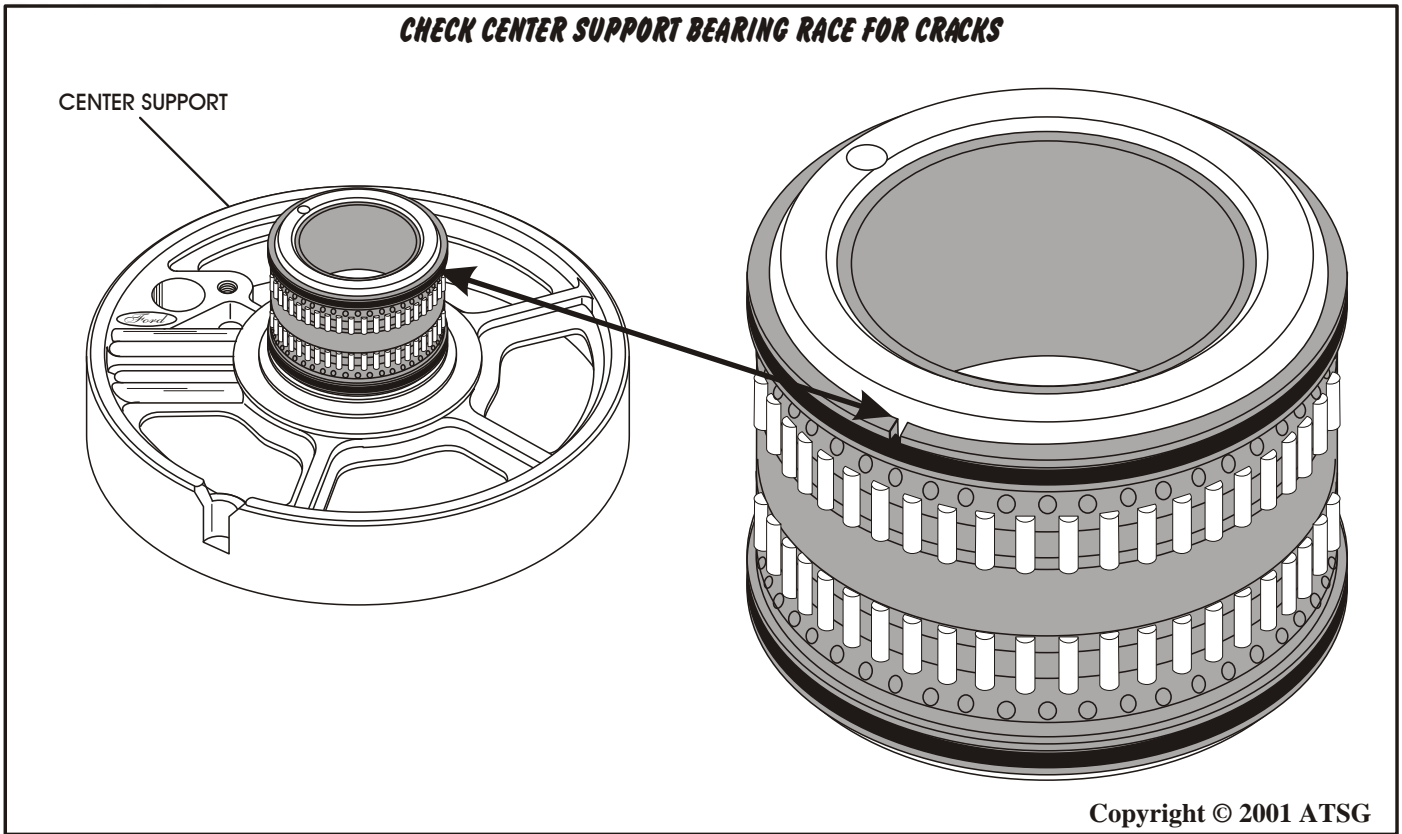

Figure 91

**EXAMPLE OF CRACKED RACE
WITH BEARING TAKEN OFF**

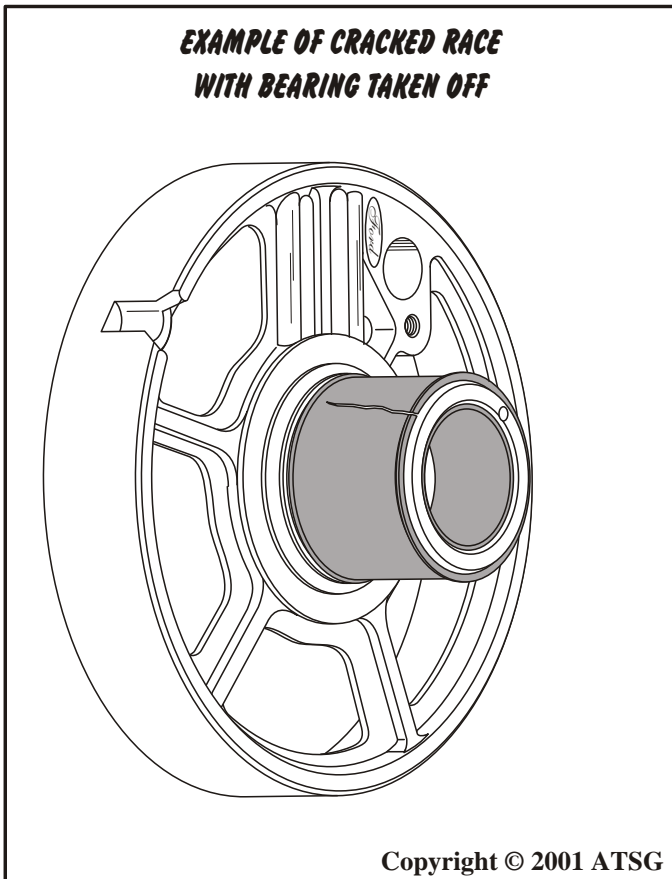

Figure 92

**INSTALL NEW SEAL RINGS
ON CENTER SUPPORT**

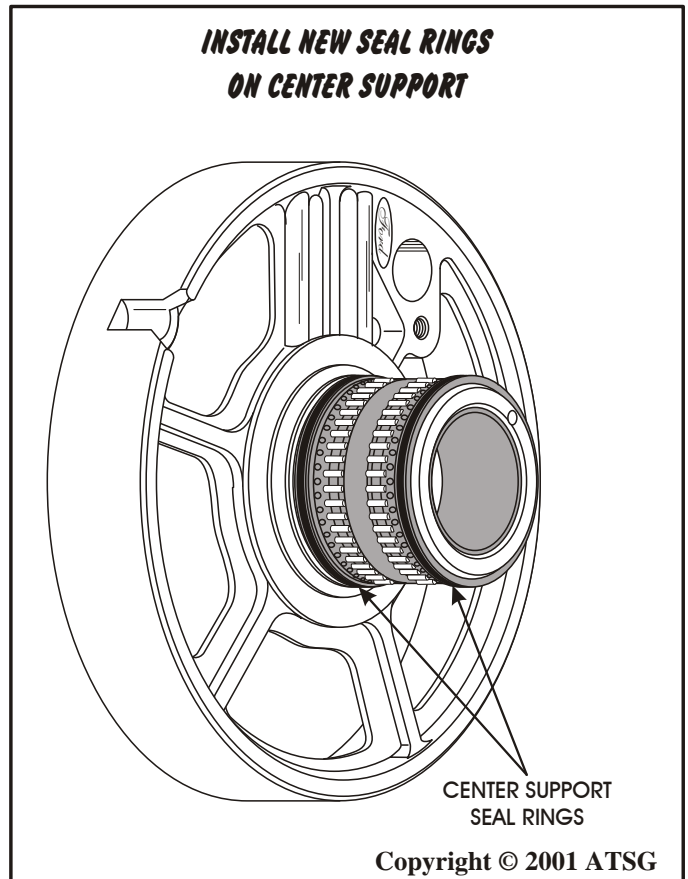

Figure 93

CENTER SUPPORT ASSEMBLY

1. The center support assembly will require some *extra inspection* to ensure it's integrity.
2. Inspect bearing race at the top of the bearing, as shown in Figure 91, for any visible cracks.
3. ***If there are any visible cracks, replacement of complete center support will be necessary, as the bearing is not available as a service item.***
4. We have seen several supports with the bearing race cracked, as shown in Figure 92. This will create leakage of direct and forward clutch oil, into each others circuit.
5. If you cannot visually see any crack, install new sealing rings onto the center support, as shown in Figure 93.
6. The ***only positive way*** to verify the integrity of the center support, is to assemble the forward and direct clutch housings, with the appropriate thrust bearings, onto the support, as shown in Figure 94.
7. Now air check the direct and forward clutch passages to ensure these passages are not connected.

Caution: This air check should be performed with every center support assembly, and then replaced as necessary.

8. After you have verified the integrity of center support assembly, set the completed support aside for the final assembly process.

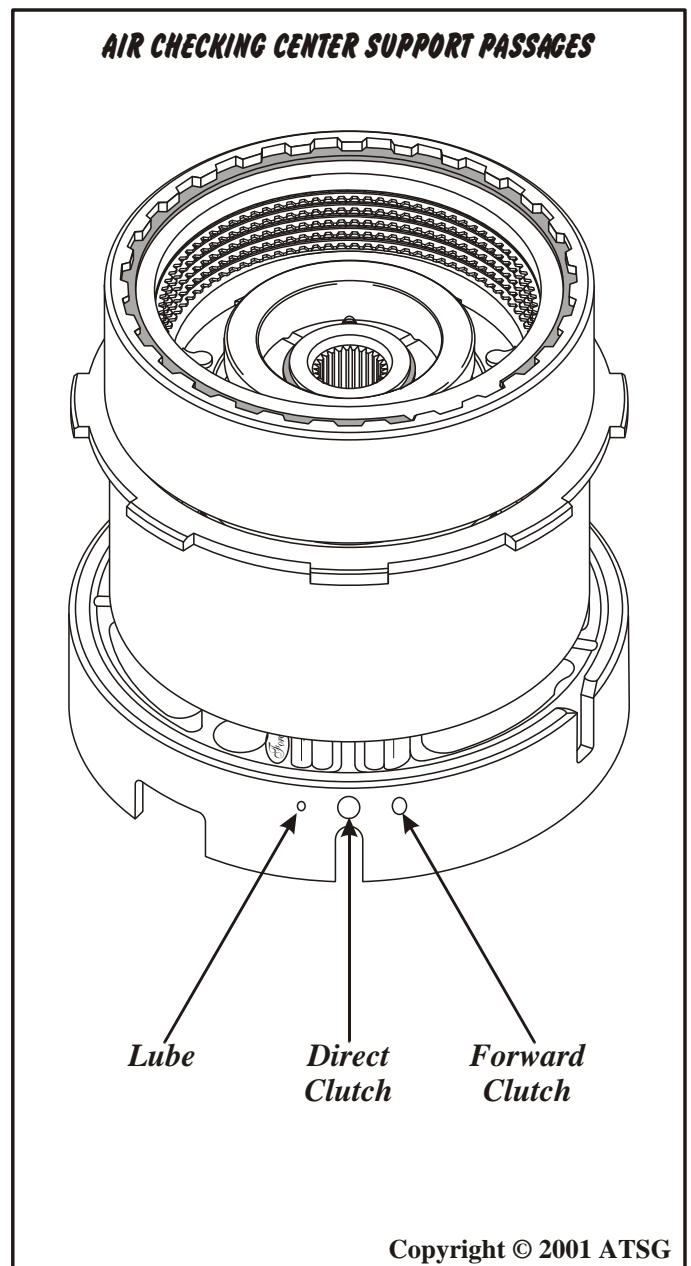

Figure 94

LOW SPRAG AND REVERSE DRUM ASSEMBLY

1. *The low sprag assembly is not yet available as a service item. If the low sprag or the bearing assembly needs replacement, the complete reverse drum assembly must be purchased.*
2. If you do take it apart, the bearing assembly must be installed first, in the direction shown in Figure 95.
3. Then install the low sprag assembly, with the tabs facing down, as shown in Figure 95, until it "Snaps" into the groove.
4. After inspection and re-assembly if necessary, set the completed reverse drum assembly aside for the final assembly process (See Figure 96).

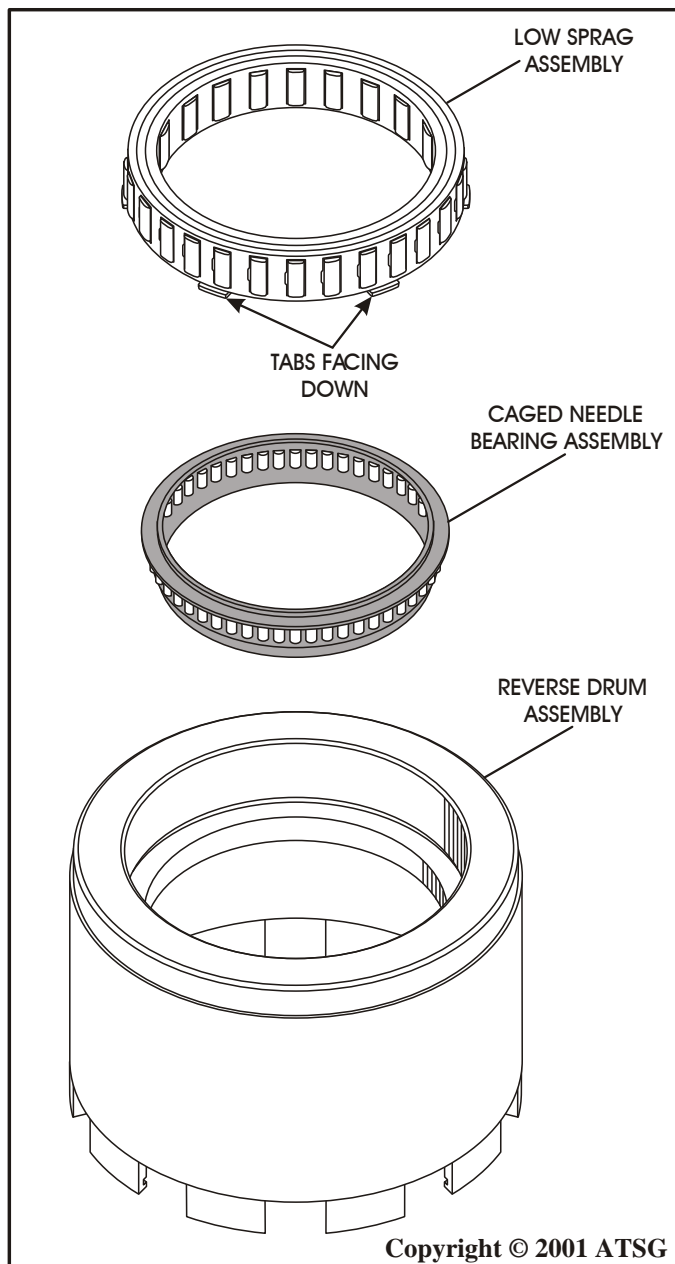

Figure 95

REAR RING GEAR AND HUB ASSEMBLY

1. Inspect all rear ring gear parts thoroughly as shown in Figure 97.
2. Remove and discard the sealing ring on the rear gear hub, as shown in Figure 97.
3. Assemble the rear ring gear hub into the rear ring gear and install the snap ring, as shown in Figure 97.
4. Install a new sealing ring into the groove in the ring gear hub, as shown in Figure 97.
Caution: *This sealing ring is manufactured with two small notches in the outside diameter as shown in Figure 98, and must be installed in this location.*
5. Set completed rear ring gear and hub assembly, as shown in Figure 99, aside for final assembly process.

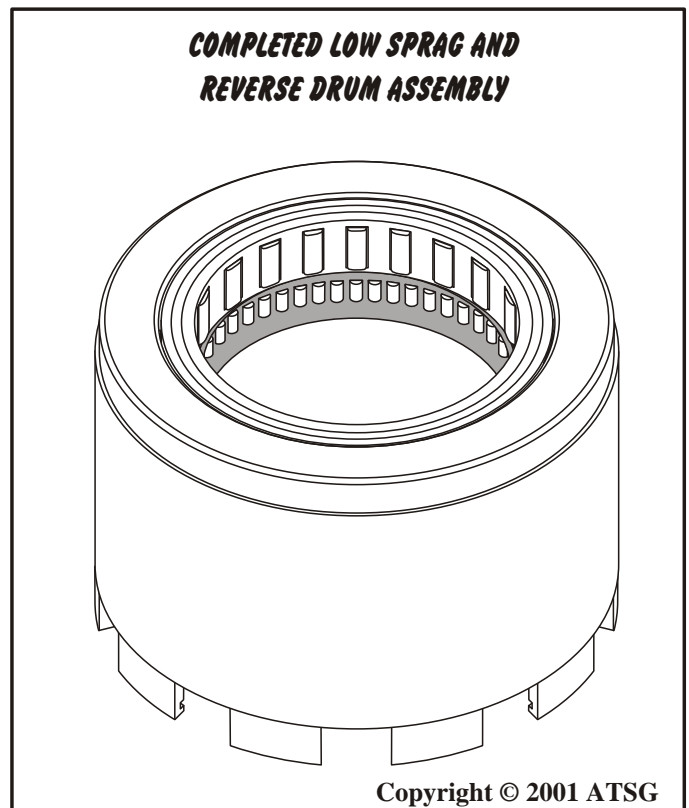

Figure 96

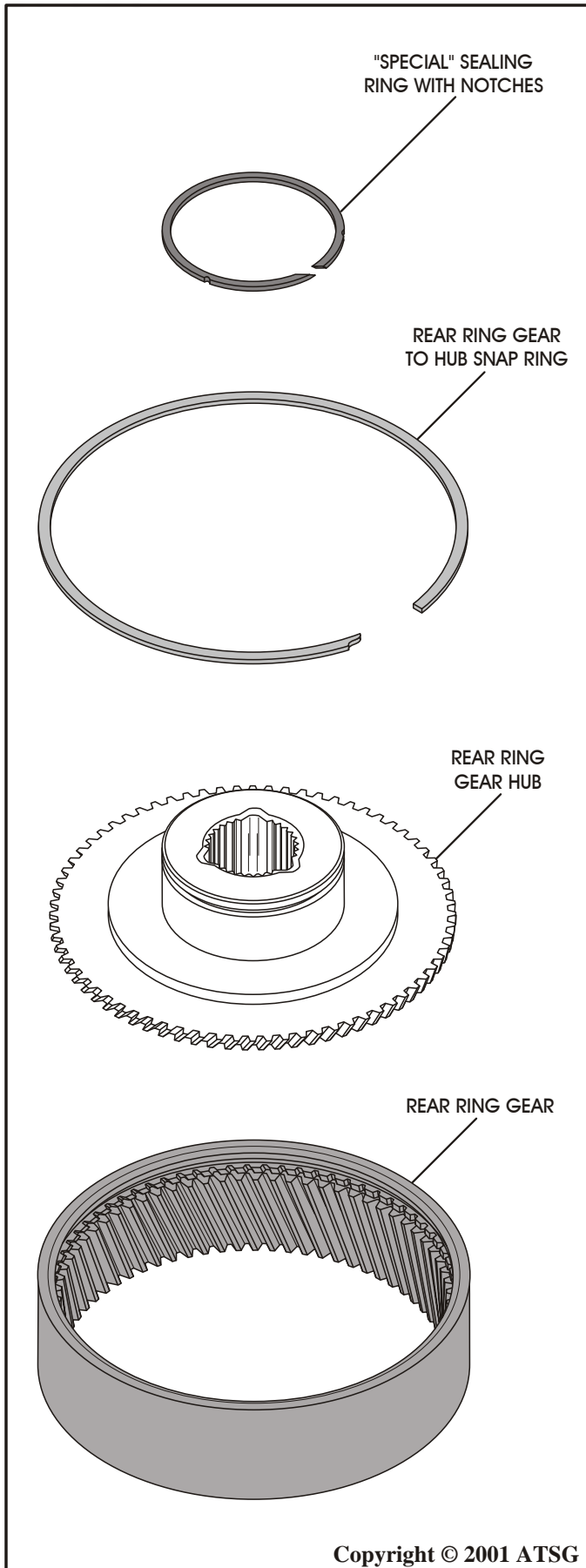

Figure 97

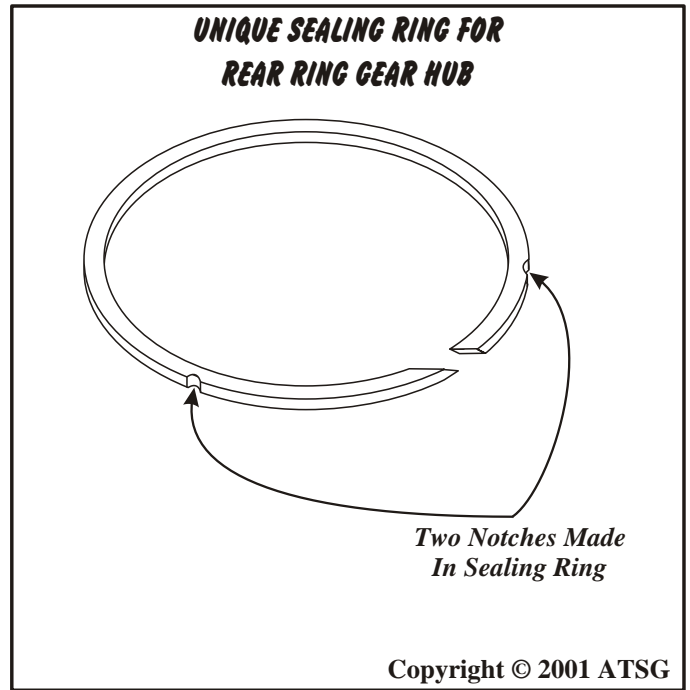

Figure 98

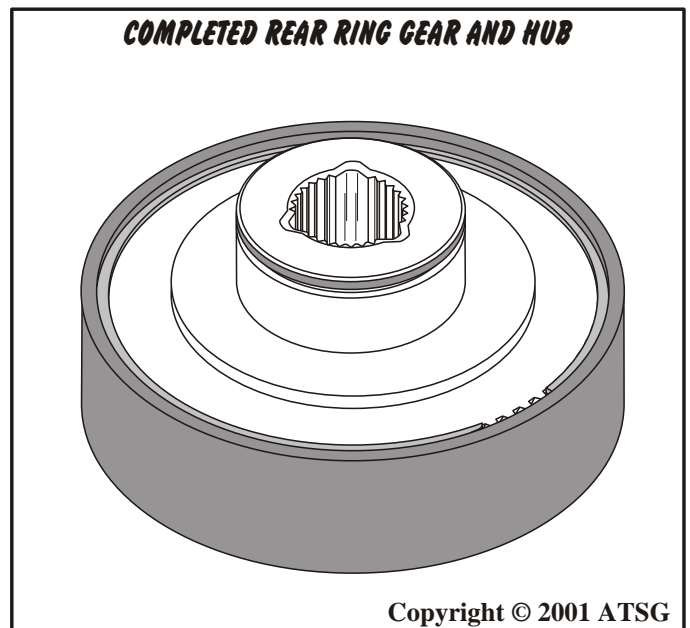

Figure 99

FRONT PLANETARY CARRIER ASSEMBLY

1. Inspect the front planetary carrier carefully for any wear and/or damage (See Figure 100).
2. Inspect the rear planetary carrier thrust bearing that is "Trapped" inside the planetary gears, for any wear and/or damage.
3. Inspect the front planetary carrier thrust washer for any wear and/or damage (See Figure 100).
4. Replace the thrust washer as necessary.
5. Install the front planetary carrier thrust washer by "Snapping" the tabs into place, as shown in Figure 100.
6. Set completed front planetary carrier assembly aside for the final assembly process. Refer to Figure 101.

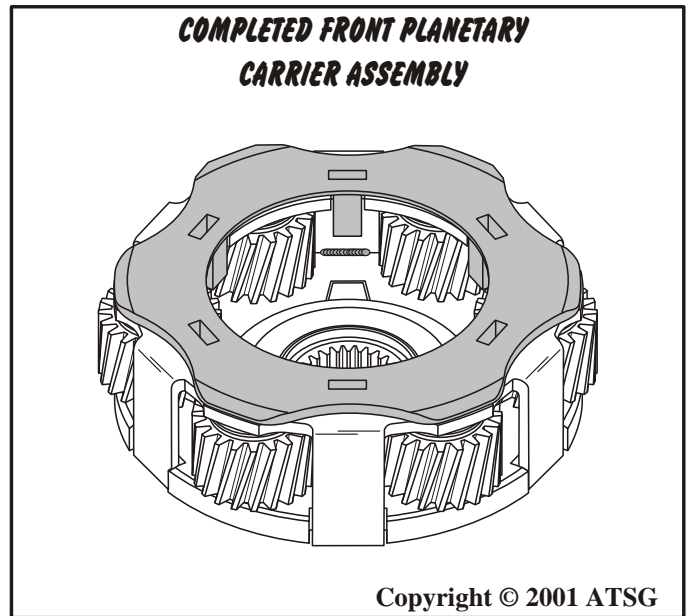

Figure 101

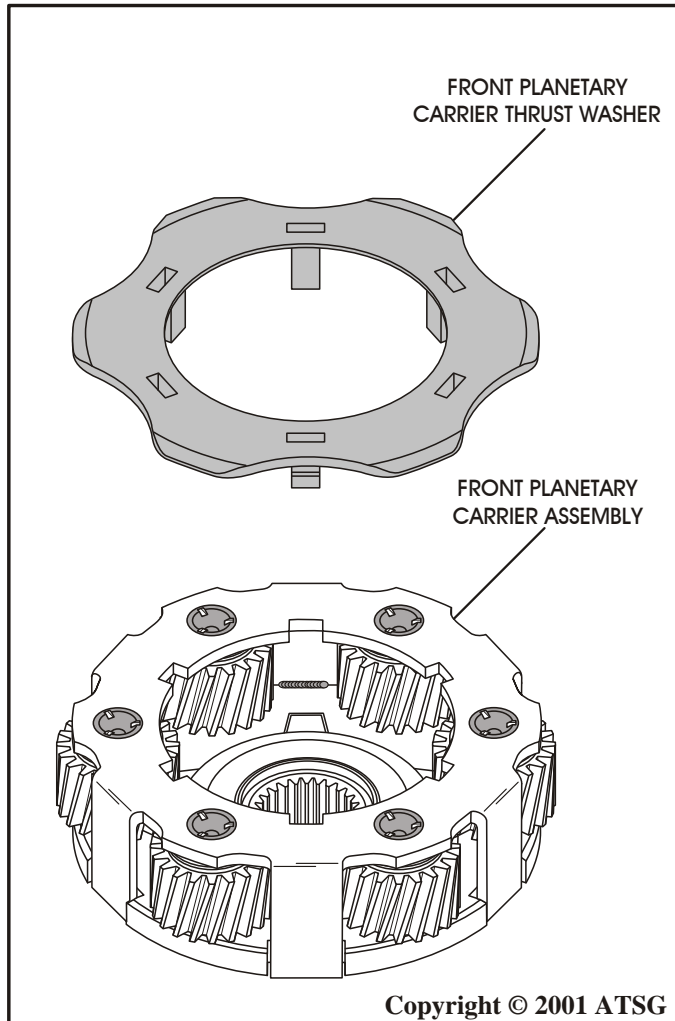

Figure 100

REAR PLANETARY CARRIER ASSEMBLY

1. Inspect the rear planetary carrier carefully for any wear and/or damage (See Figure 102).
2. Set completed rear planetary carrier assembly aside for the final assembly process. Refer to Figure 102.

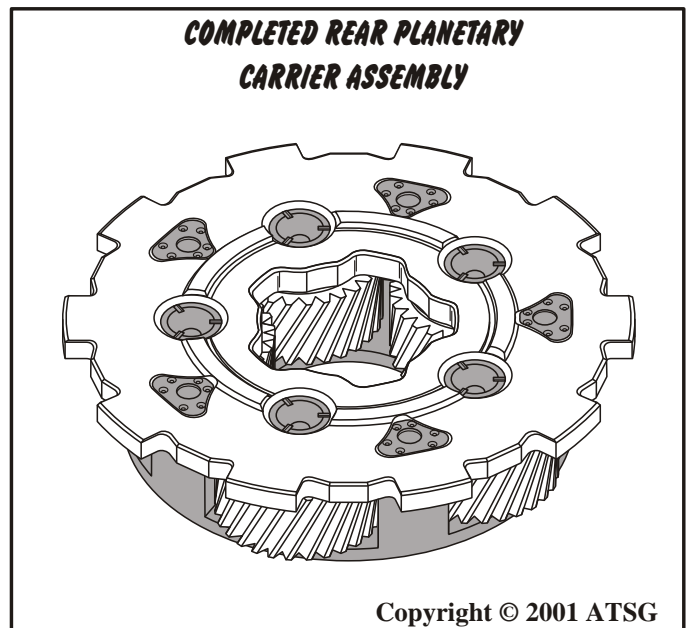

Figure 102

INTERMEDIATE SPRAG ASSEMBLY

1. Disassemble the intermediate sprag and sun gear shell assembly parts using the illustrations shown in Figure 103.
2. Inspect all intermediate sprag parts thoroughly for any wear and/or damage.
3. Clean all intermediate sprag parts thoroughly and dry with compressed air.

Continued on Page 67

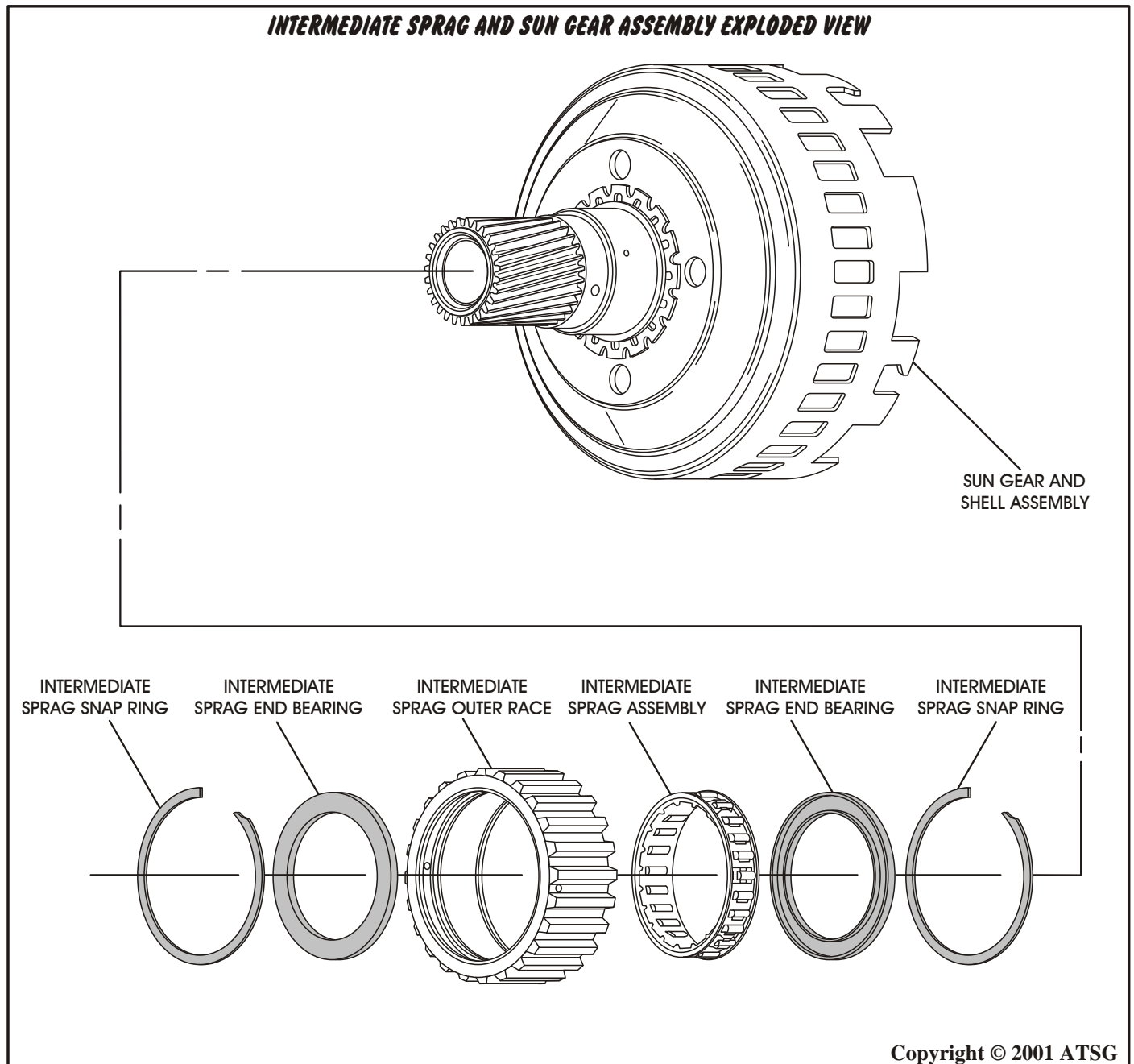

Figure 103

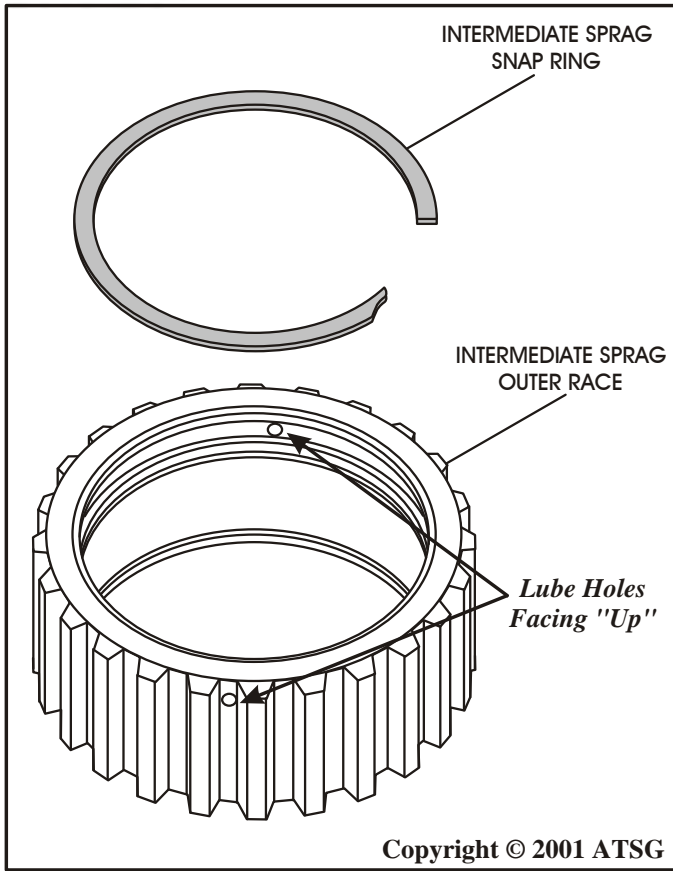

Figure 104

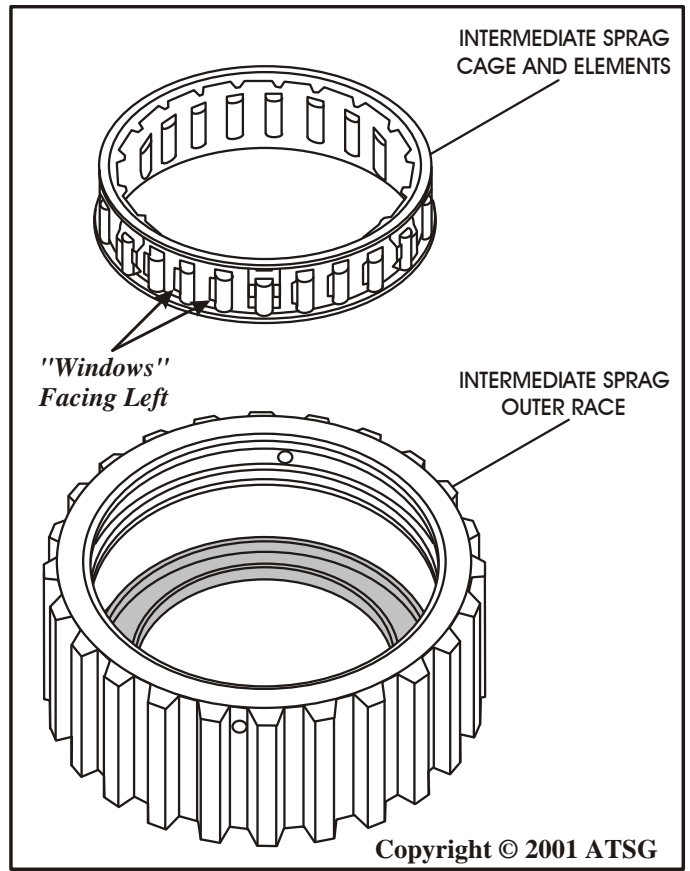

Figure 106

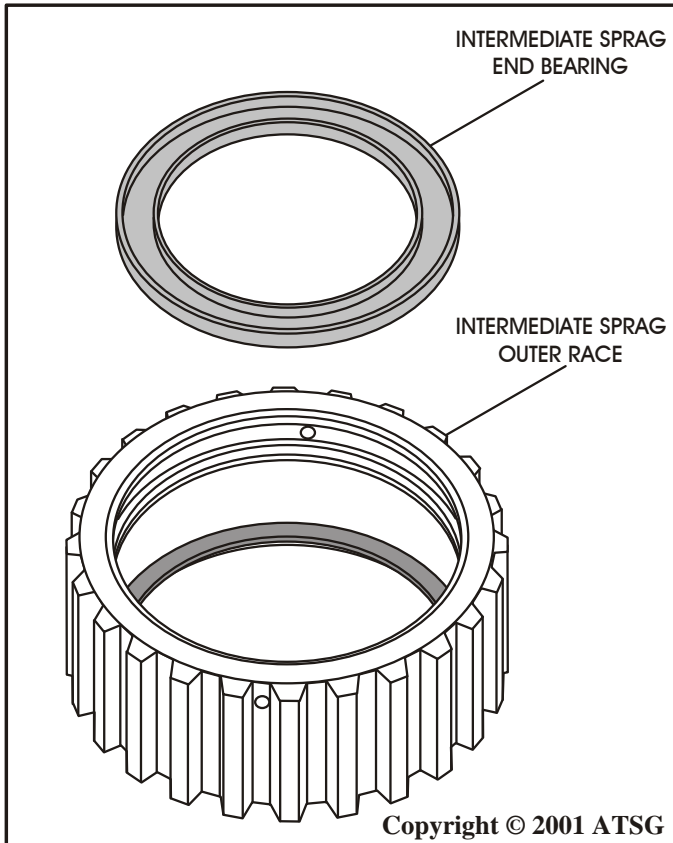

Figure 105

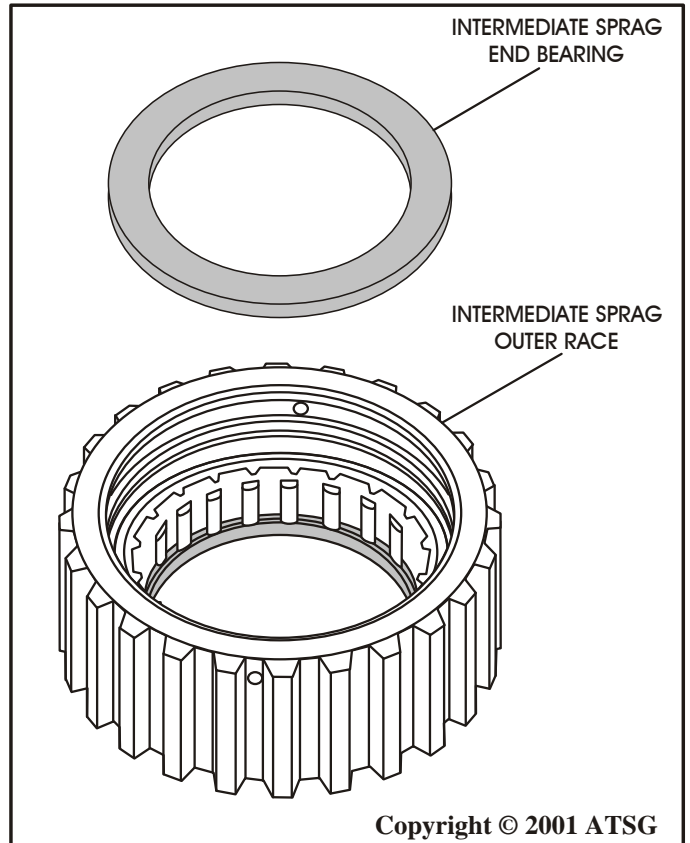

Figure 107

INTERMEDIATE SPRAG ASSEMBLY

4. Place the sprag outer race on a flat work bench with the *lube holes facing up*, as illustrated in Figure 104.

CAUTION: *The sprag outer race must be placed in this position during assembly as outside splines are cut off-set and will not assemble into the intermediate clutch plates even though the outer race freewheels in the proper direction (See Figure 104).*

5. Install one snap ring into the bottom groove in the sprag outer race, as shown in Figure 104.

6. Install one sprag end bearing on top of the previously installed snap ring, with grooved side facing up, as shown in Figure 105.

7. Install the intermediate sprag cage and element assembly into the outer race, with "Windows" *facing to the left*, as shown in Figure 106.

CAUTION: *The "Windows" must face in the direction shown in Figure 106, for sprag rotation to be correct.*

8. Install the second end bearing on top of the sprag cage with the smooth side facing up, as shown in Figure 107.

9. Install the second snap ring into the groove in the outer race, as shown in Figure 108.

10. The completed intermediate sprag assembly should look like the illustration shown in Figure 109.

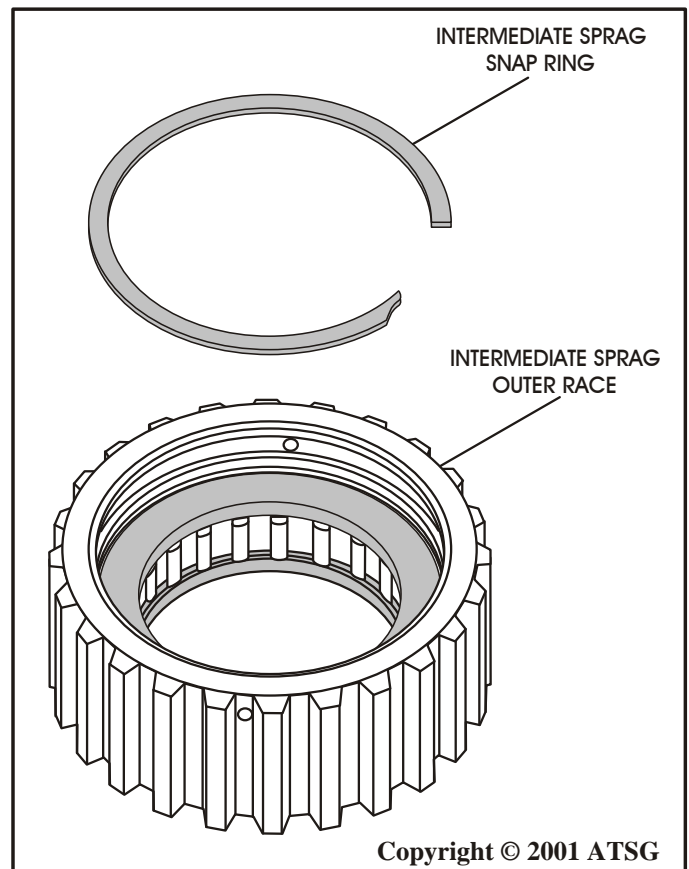

Figure 108

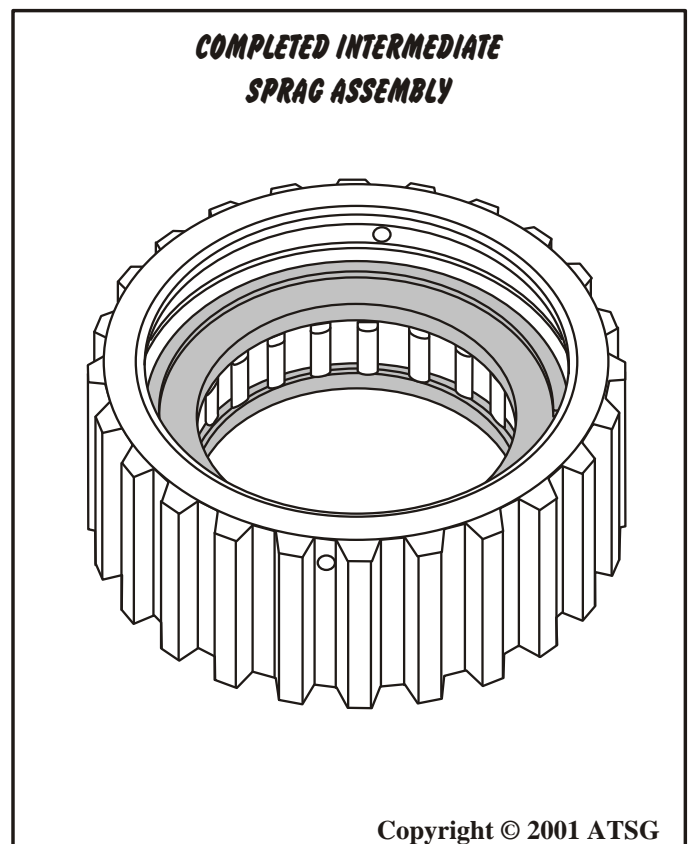

Figure 109

Continued on Page 68

INTERMEDIATE SPRAG ASSEMBLY

11. Install completed intermediate sprag assembly onto sun gear and shell assembly assembly by rotating in a clock-wise direction, as shown in Figure 110.
12. Intermediate sprag outer race *must* freewheel in clockwise direction and lock counter-clockwise as shown in Figure 111.
13. Set the completed intermediate sprag and sun gear assembly aside for final assembly.

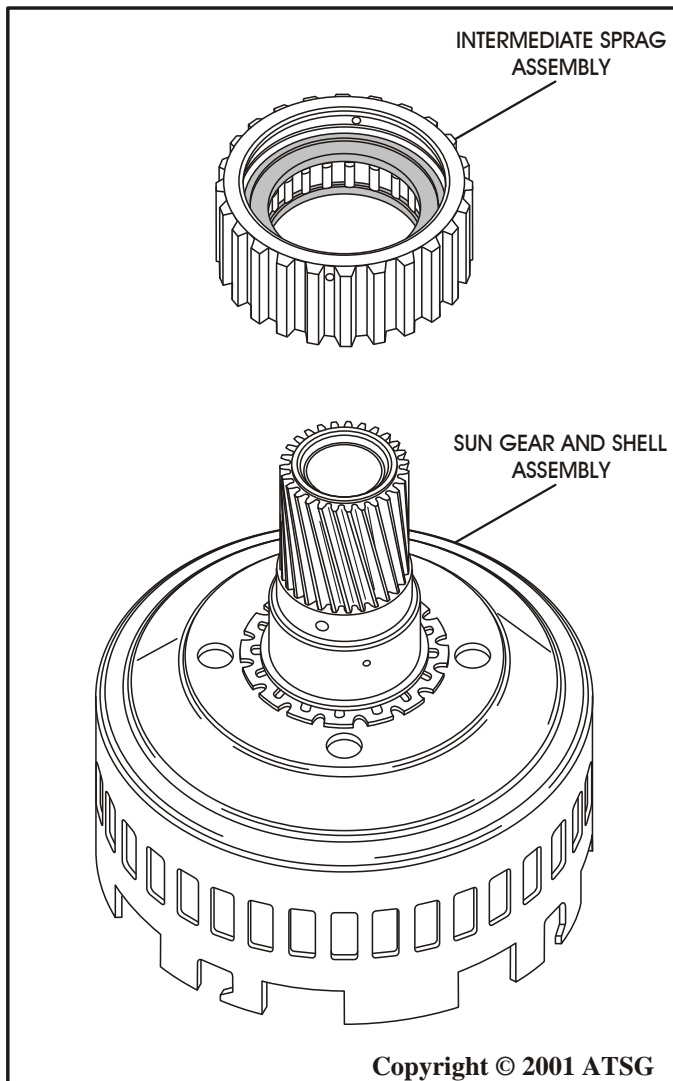

Figure 110

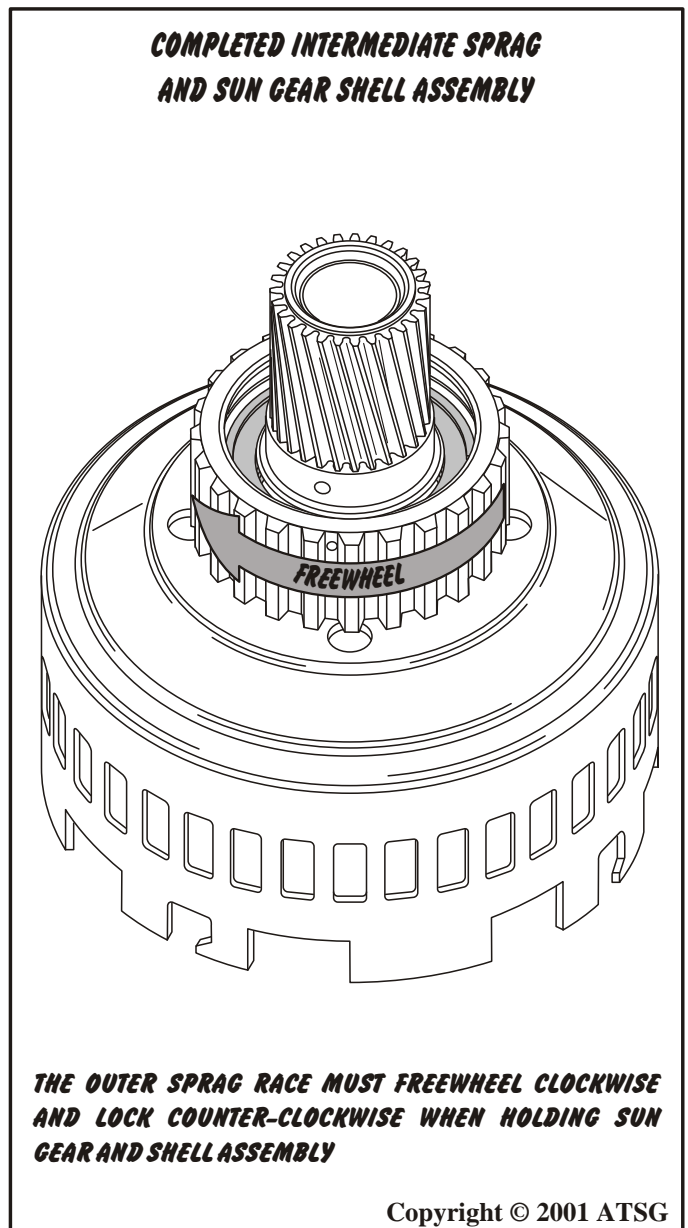

Figure 111

INTERMEDIATE CLUTCH ASSEMBLY

1. Disassemble the intermediate clutch assembly using illustrations in Figure 112 as a guide.
2. Inspect all intermediate clutch parts thoroughly for any wear and/or damage.
3. Clean all intermediate clutch parts thoroughly and dry with compressed air.
4. Inspect intermediate clutch molded piston and replace as necessary.
5. Note that the intermediate clutch plates are the single sided design, as shown in Figure 112. *Note: These plates have a special "off-set" machining on the teeth, so that they will not assemble in transmission if installed wrong.*

Continued on Page 70

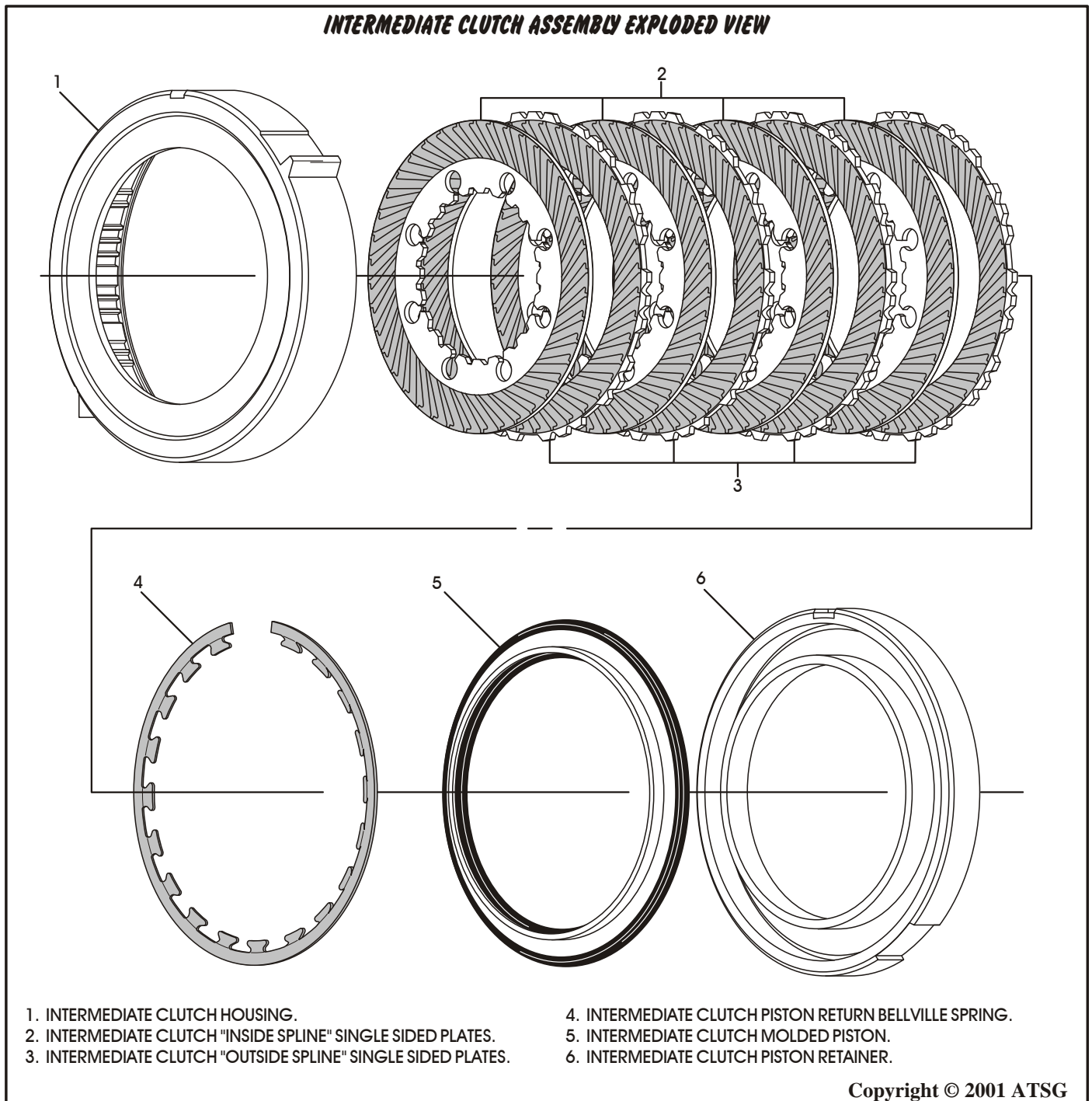

Figure 112

INTERMEDIATE CLUTCH ASSEMBLY (Cont'd)

6. Install the intermediate clutch plates into the intermediate clutch housing beginning with an inside spline plate first, with the lining facing down, as shown in Figure 113.
7. Now alternate with outside spline plates, with the lining facing down, as shown in Figure 113, until you have installed four of each plate.
8. The last plate in should be an outside spline plate, with the lining facing down, as shown in Figure 113.

Note: *These plates have a special off-set machining on the teeth, so that they will not assemble in transmission if installed wrong in the intermediate clutch housing. All friction plates should be soaked in Mercon V® for at least 30 minutes before installation.*

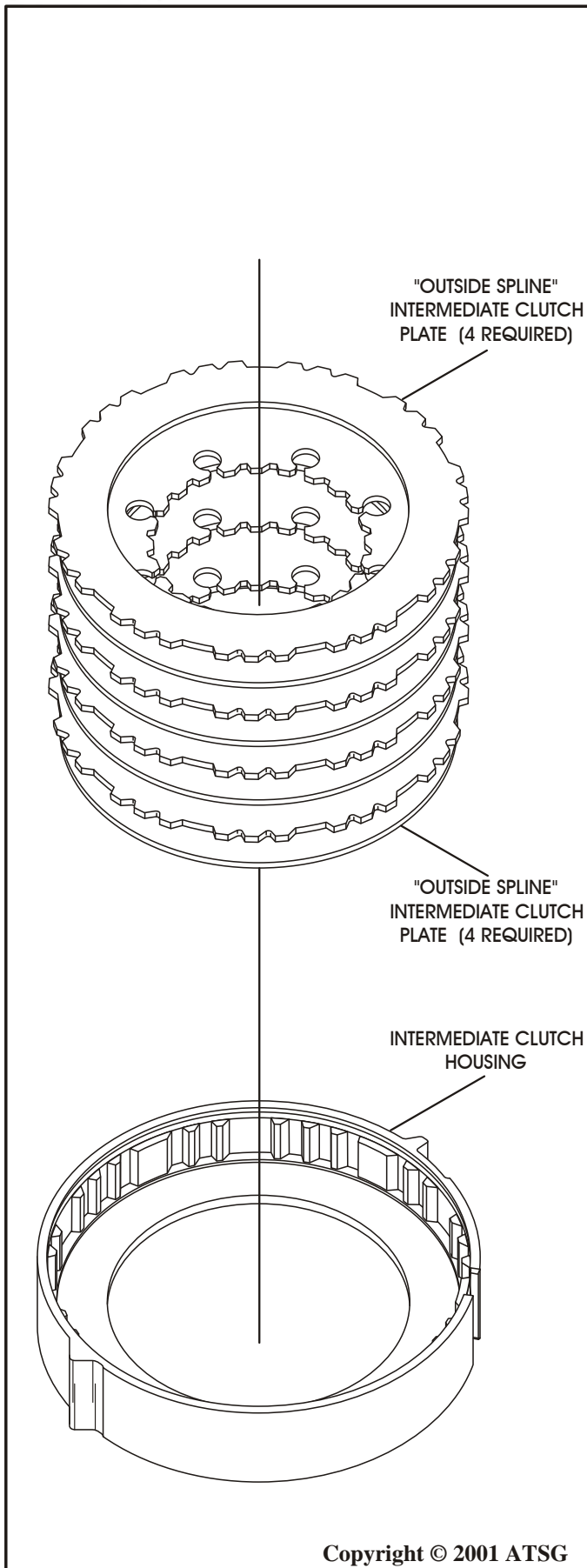

Figure 113

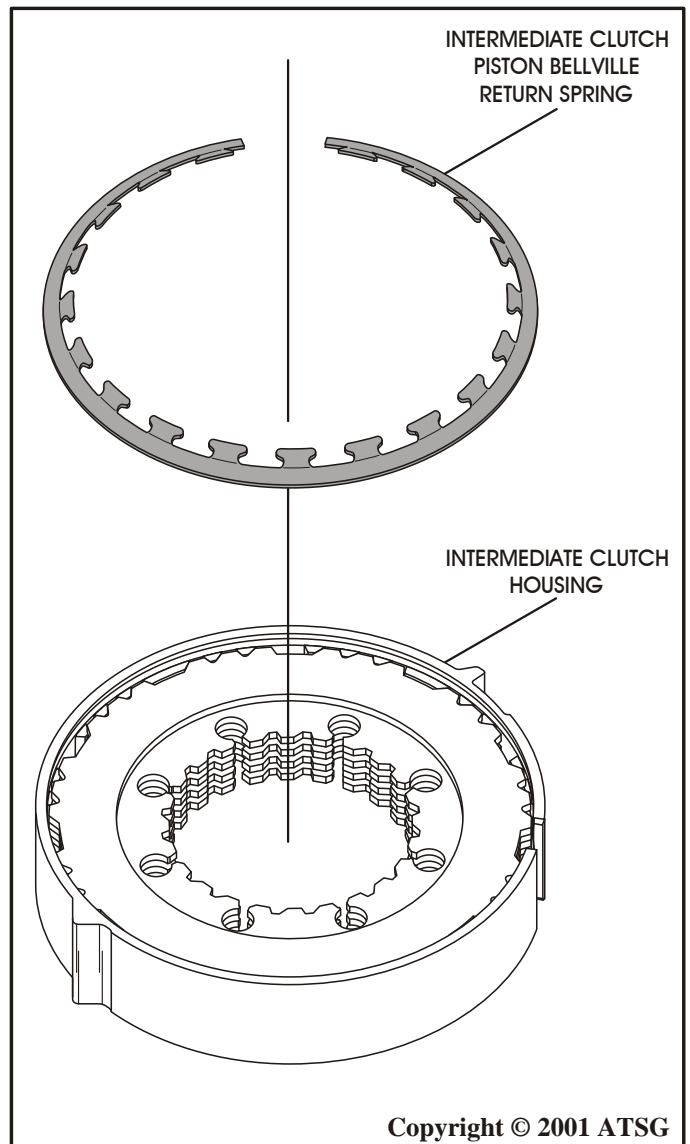

Figure 114

INTERMEDIATE CLUTCH ASSEMBLY (Cont'd)

9. Install the intermediate clutch bellville return spring into the groove in intermediate clutch housing, as shown in Figure 114, and ensure that it is fully seated.
10. Lubricate intermediate clutch molded piston with a small amount of Trans-Jel®.
11. Lubricate both seal surfaces of the intermediate clutch piston retainer with a small amount of Trans-Jel®.
12. Install the intermediate clutch piston into the intermediate clutch piston retainer, as shown in Figure 115, with a twisting motion.
13. Set the completed intermediate clutch housing assembly and completed intermediate clutch piston retainer assembly aside for the final assembly process (See Figure 116).

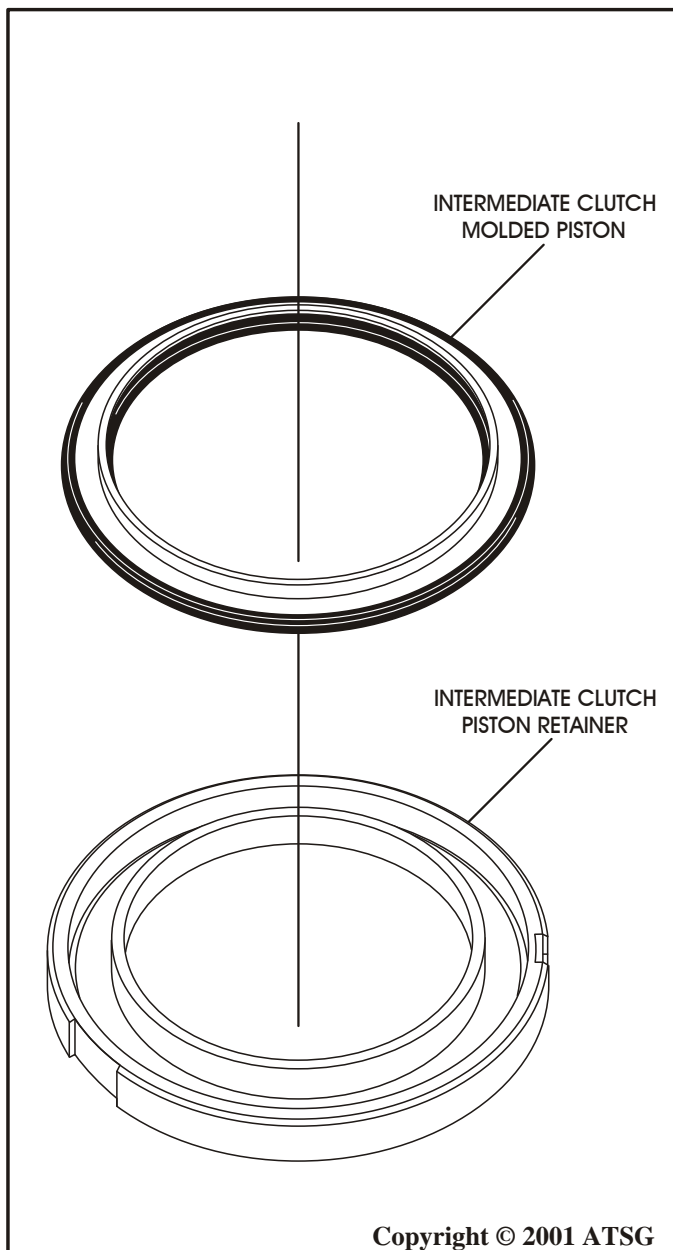

Figure 115

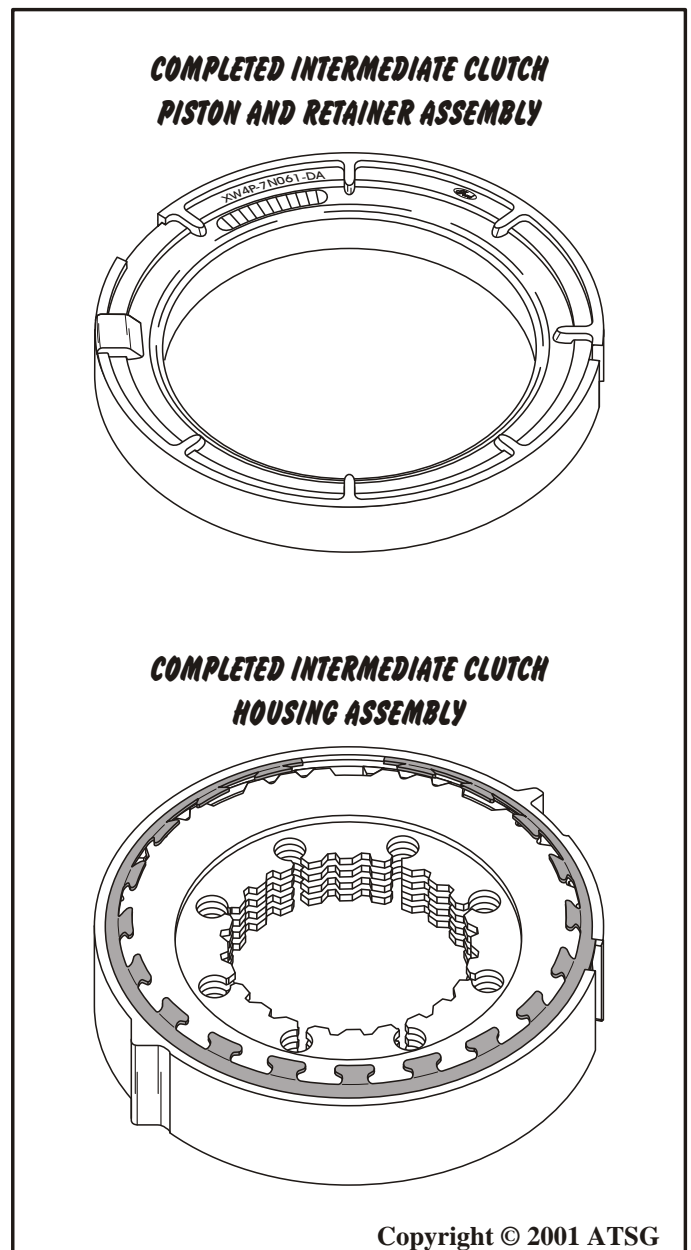
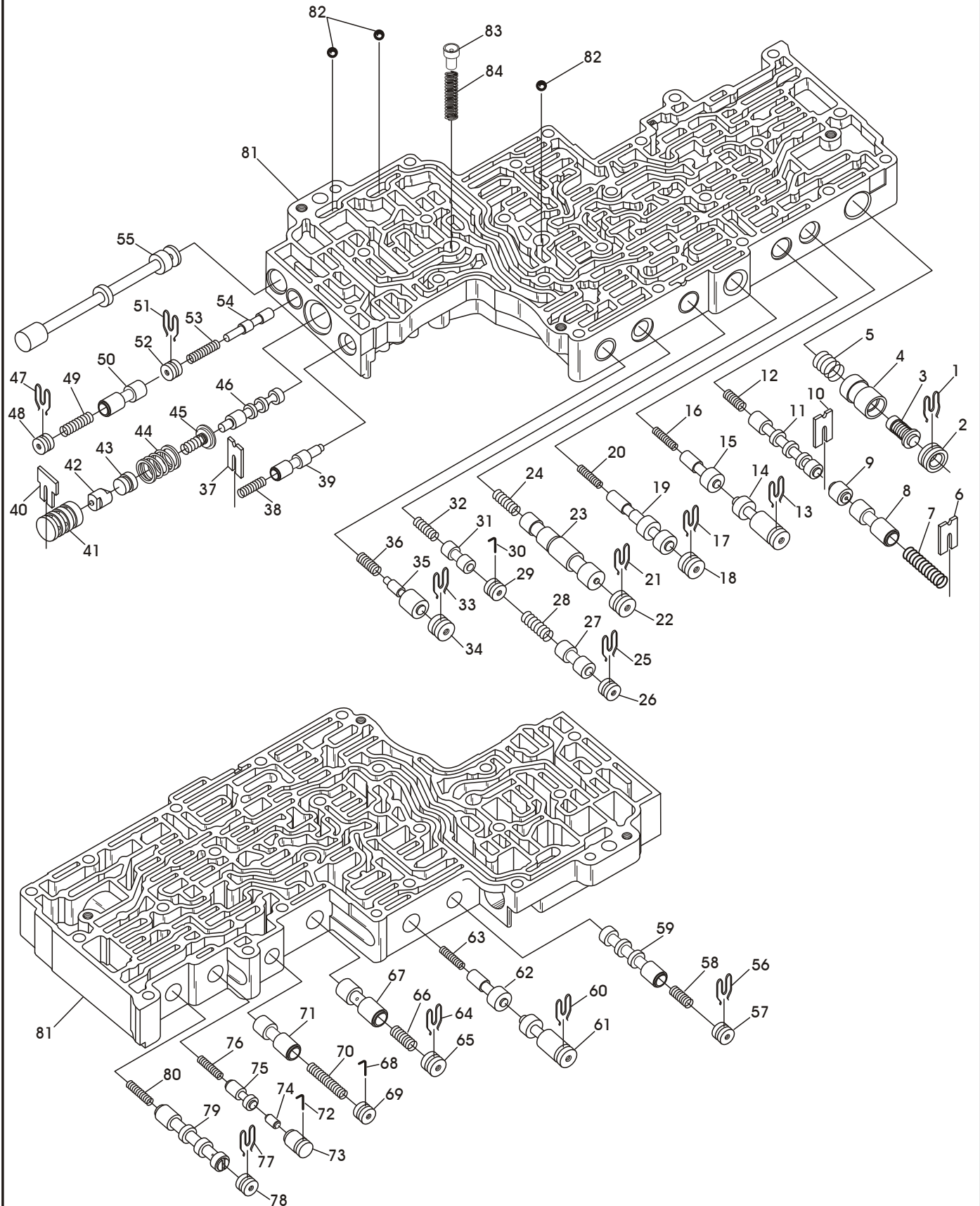

Figure 116

VALVE BODY ASSEMBLY EXPLODED VIEW



Copyright © 2001 ATSG

Figure 117



Technical Service Information

VALVE BODY ASSEMBLY

1. Disassemble the main valve body assembly using Figure 117 as a guide.
2. Lay each valve line-up out in order as you remove them from the valve body casting.
3. Inspect each valve, valve spring, bore plug and retainers for any wear and/or damage. Replace complete valve body as necessary.
4. Clean all valve body parts thoroughly and dry with compressed air.
5. Install each valve train back into their bores *exactly* as shown in Figure 117, lubricating them with Mercon V® as they are installed.
6. Refer to Figure 118 for the *exact* placement of retaining pins and clips, as some of them are installed inboard in the worm tracks of the valve body casting.
7. Extra care here will eliminate some of the troublesome problems encountered later.

Continued on Page 74

VALVE BODY LEGEND

- | | |
|---|--|
| 1. COOLER BYPASS VALVE RETAINER CLIP | 44. MAIN REGULATOR VALVE OUTER SPRING |
| 2. COOLER BYPASS VALVE BORE PLUG | 45. MAIN REGULATOR VALVE INNER SPRING AND RETAINER |
| 3. THERMO VALVE ASSEMBLY | 46. MAIN REGULATOR VALVE |
| 4. COOLER BYPASS VALVE | 47. REVERSE INHIBIT VALVE BORE PLUG RETAINER CLIP |
| 5. COOLER BYPASS VALVE SPRING | 48. REVERSE INHIBIT VALVE BORE PLUG |
| 6. COAST CLUTCH CONTROL VALVE RETAINER PLATE | 49. REVERSE INHIBIT VALVE SPRING |
| 7. COAST CLUTCH CONTROL VALVE SPRING | 50. REVERSE INHIBIT VALVE |
| 8. COAST CLUTCH CONTROL VALVE | 51. SOLENOID REGULATOR VALVE BORE PLUG RETAINER CLIP |
| 9. COAST CLUTCH CONTROL VALVE BORE PLUG | 52. SOLENOID REGULATOR VALVE BORE PLUG |
| 10. OVERDRIVE SERVO CONTROL VALVE RETAINER PLATE | 53. SOLENOID REGULATOR VALVE SPRING |
| 11. OVERDRIVE SERVO CONTROL VALVE | 54. SOLENOID REGULATOR VALVE |
| 12. OVERDRIVE CONTROL VALVE SPRING | 55. MANUAL SHIFT CONTROL VALVE |
| 13. MODULATOR VALVE RETAINER CLIP | 56. SELECT VALVE BORE PLUG RETAINER CLIP |
| 14. MODULATOR VALVE BORE PLUG | 57. SELECT VALVE BORE PLUG |
| 15. MODULATOR VALVE | 58. SELECT VALVE SPRING |
| 16. MODULATOR VALVE SPRING | 59. SELECT VALVE |
| 17. 4-3 INT. SERVO REG. DOWNSHIFT CONTROL VALVE CLIP | 60. MODULATOR VALVE BORE PLUG RETAINER CLIP |
| 18. 4-3 INT. SERVO REG. DOWNSHIFT CONTROL VALVE BORE PLUG | 61. MODULATOR VALVE BORE PLUG |
| 19. 4-3 INT. SERVO REG. DOWNSHIFT CONTROL VALVE | 62. MODULATOR VALVE |
| 20. 4-3 INT. SERVO REG. DOWNSHIFT CONTROL VALVE SPRING | 63. MODULATOR VALVE SPRING |
| 21. 4-3 PRE-STROKE INT. BAND CONTROL VALVE RETAINER CLIP | 64. FORWARD ENGAGEMENT CONTROL VALVE RETAINER CLIP |
| 22. 4-3 PRE-STROKE INT. BAND CONTROL VALVE BORE PLUG | 65. FORWARD ENGAGEMENT CONTROL VALVE BORE PLUG |
| 23. 4-3 PRE-STROKE INT. BAND CONTROL VALVE | 66. FORWARD ENGAGEMENT CONTROL VALVE SPRING |
| 24. 4-3 PRE-STROKE INT BAND CONTROL VALVE SPRING | 67. FORWARD ENGAGEMENT CONTROL VALVE |
| 25. REVERSE ENGAGEMENT VALVE RETAINER CLIP | 68. TCC BACK PRESSURE VALVE BORE PLUG RETAINER CLIP |
| 26. REVERSE ENGAGEMENT VALVE BORE PLUG | 69. TCC BACK PRESSURE VALVE BORE PLUG |
| 27. REVERSE ENGAGEMENT VALVE | 70. TCC BACK PRESSURE VALVE SPRING |
| 28. REVERSE ENGAGEMENT VALVE SPRING | 71. TCC BACK PRESSURE VALVE |
| 29. HIGH CLUTCH CONTROL VALVE BORE PLUG | 72. TCC MODULATOR CONTROL VALVE SLEEVE RETAINER CLIP |
| 30. HIGH CLUTCH CONTROL VALVE BORE PLUG RETAINER | 73. TCC MODULATOR CONTROL VALVE SLEEVE |
| 31. HIGH CLUTCH CONTROL VALVE | 74. TCC MODULATOR CONTROL VALVE |
| 32. HIGH CLUTCH CONTROL VALVE SPRING | 75. TCC MODULATOR VALVE |
| 33. REVERSE MODULATOR VALVE BORE PLUG RETAINER CLIP | 76. TCC MODULATOR VALVE SPRING |
| 34. REVERSE MODULATOR VALVE BORE PLUG | 77. TCC CONTROL VALVE BORE PLUG RETAINER CLIP |
| 35. REVERSE MODULATOR VALVE | 78. TCC CONTROL VALVE BORE PLUG |
| 36. REVERSE MODULATOR VALVE SPRING | 79. TCC CONTROL VALVE |
| 37. REAR SERVO CONTROL VALVE RETAINER PLATE | 80. TCC CONTROL VALVE SPRING |
| 38. REAR SERVO CONTROL VALVE SPRING | 81. MAIN VALVE BODY CASTING |
| 39. REAR SERVO CONTROL VALVE | 82. RUBBER CHECKBALLS .250" DIAMETER (3 REQUIRED) |
| 40. MAIN REGULATOR BOOST VALVE SLEEVE RETAINER PLATE | 83. PRESSURE CONTROL LIMIT VALVE |
| 41. MAIN REGULATOR VALVE BOOST SLEEVE | 84. PRESSURE CONTROL LIMIT VALVE SPRING |
| 42. MAIN REGULATOR LINE BOOST VALVE | |
| 43. MAIN REGULATOR REVERSE BOOST VALVE | |

Copyright © 2001 ATSG

Figure 117 "LEGEND"

VALVE BODY ASSEMBLY (Cont'd)

8. Ensure that the valve train retainers have been installed in their proper locations, as shown in Figure 118.
9. Lubricate all installed valve trains with a small amount of Mercon V®, before installing the valve body spacer plate.
10. Install the three .250" Viton checkballs into the locations shown in Figure 119.
11. Install the pressure control limit valve and spring into the proper location, as shown in Figure 119.
12. Install two valve body spacer plate alignment dowels in the locations shown in Figure 119.
13. **Special Note: The valve body spacer plate has bonded gaskets on both sides, and Ford Motor Co. recommends replacement of the spacer plate on all rebuilds.**
14. Most aftermarket gasket kits come equipped with new valve body gaskets, but the top and bottom gaskets are different.
15. These new gaskets may be used if you can successfully remove the old gaskets without damage to the spacer plate.
16. Install the new gaskets on the proper sides of spacer plate and place over alignment dowels, or install a new Ford spacer plate assembly, as shown in Figure 119.
17. Install the three spacer plate retaining bolts, as shown in Figure 119, and torque the bolts to 10 Nm (89 in.lb.).
18. Remove the alignment dowels and set the completed valve body assembly aside for the final assembly process.

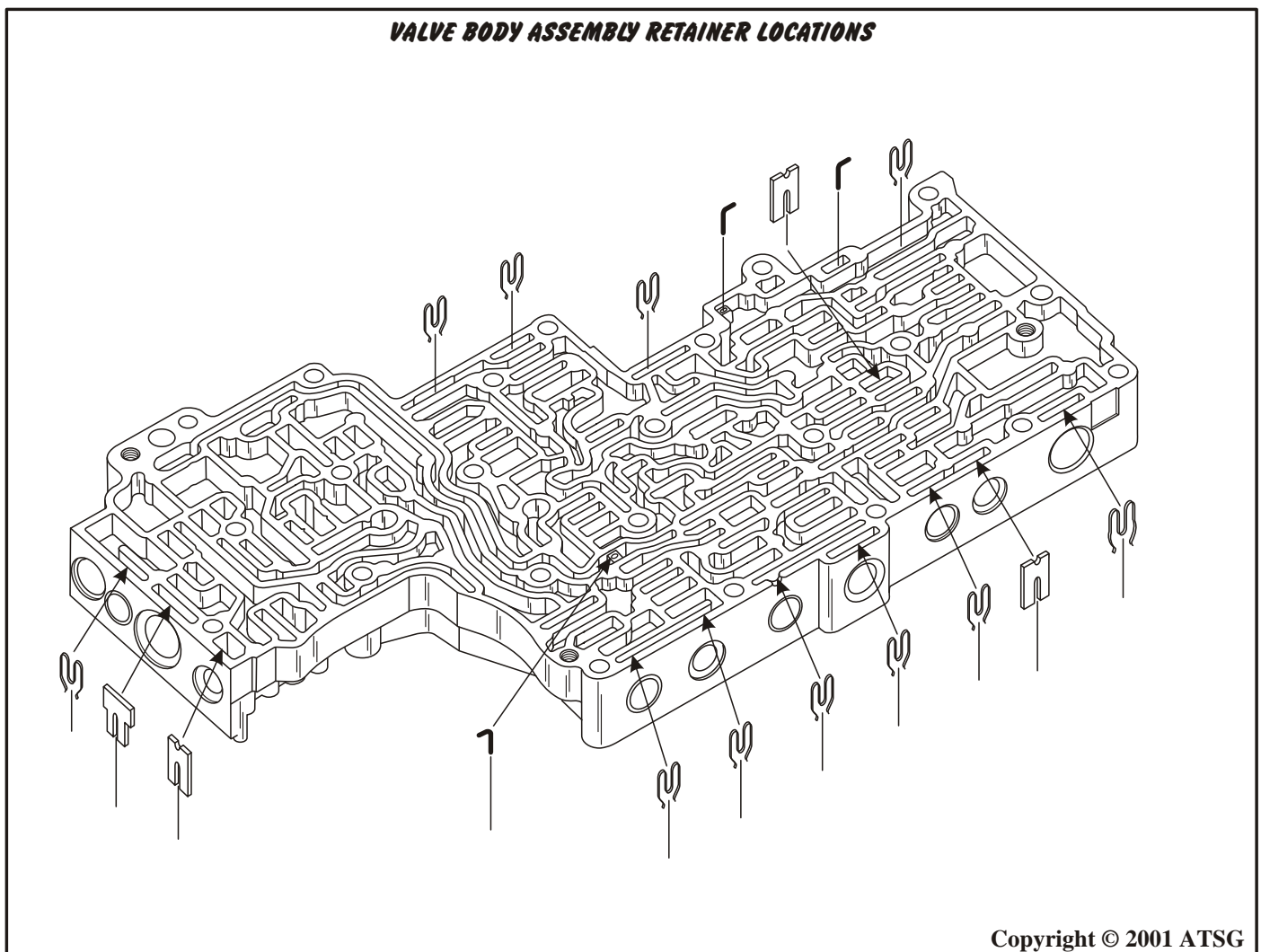

Figure 118

VALVE BODY SPACER PLATE AND GASKETS

SPACER PLATE
RETAINING BOLT
(3 REQUIRED)

SPACER PLATE
RETAINING BOLT
(3 REQUIRED)

"NEW" SPACER PLATE WITH BONDED GASKETS
OR CLEAN PLATE WITH AFTERMARKET GASKETS

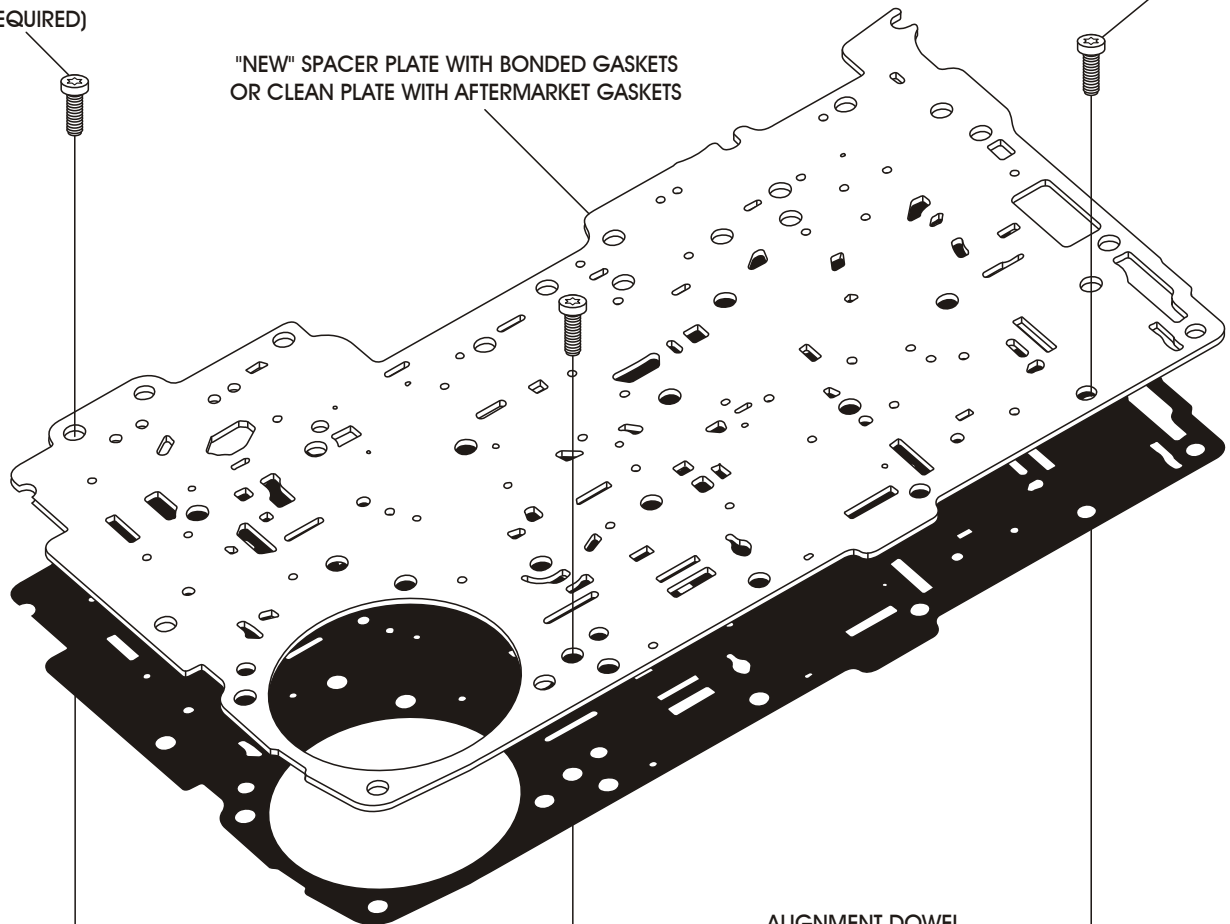

.250" VITON BALLS
(3 REQUIRED)

RELIEF VALVE
AND SPRING

ALIGNMENT DOWEL
(2 REQUIRED)

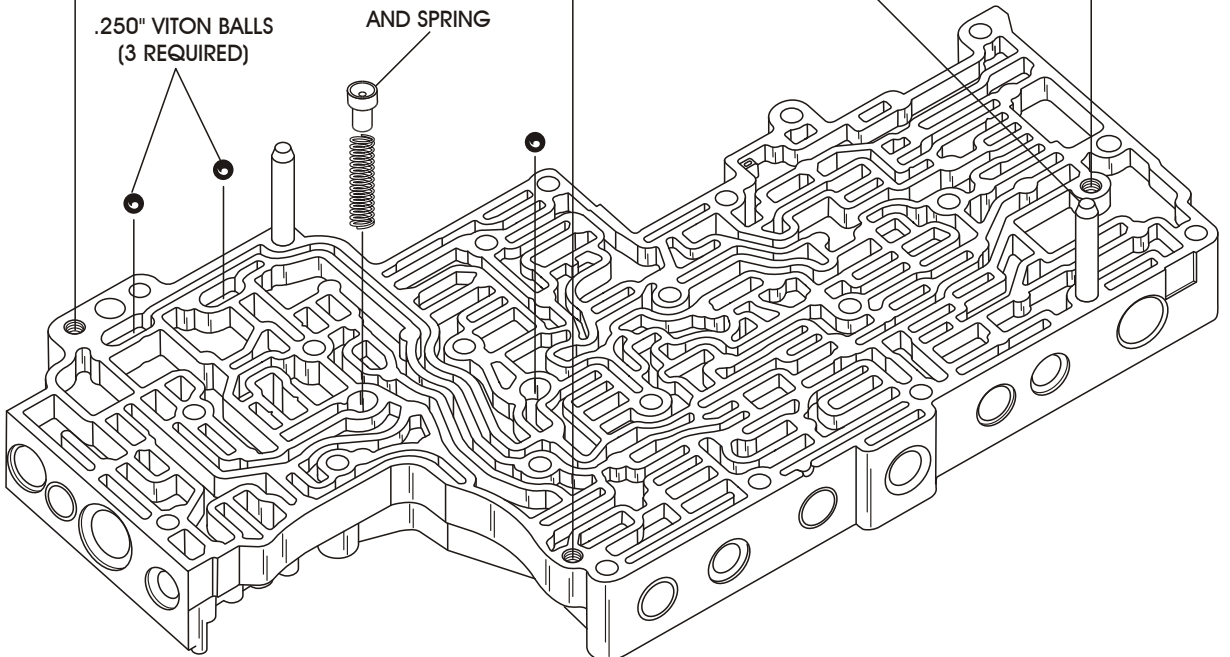

Copyright © 2001 ATSG

Figure 119

REVERSE SERVO ASSEMBLY

1. Disassemble the reverse servo assembly using Figure 121 as a guide.
2. Tabs on the reverse servo cover plate mate with slots in the reverse housing every 120 degrees.
3. Remove reverse servo cover plate by turning in either direction to release. Align the arrow on the cover plate with any slot on the housing, as shown in Figure 120.
4. Inspect all reverse servo parts thoroughly for any wear and/or damage.

Note: *The reverse servo piston has a molded seal, as shown in Figure 121. Replace the piston assembly as necessary.*

5. Remove and discard the reverse servo piston inner "D" ring seal from the servo housing, as shown in Figure 121.
6. Remove and inspect the reverse servo check valve and spring, as shown in Figure 121.

Continued on Page 77

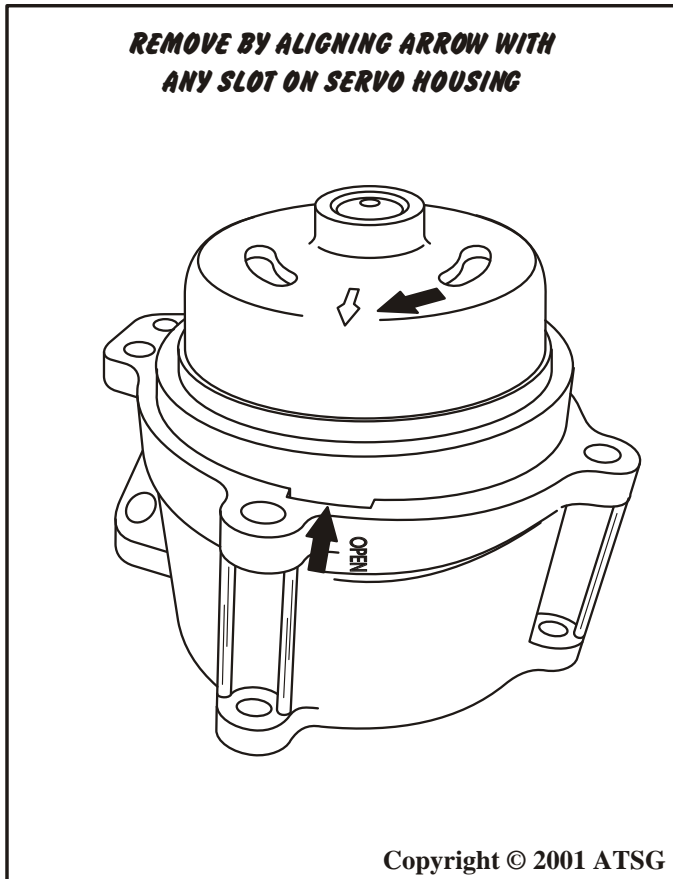

Figure 120

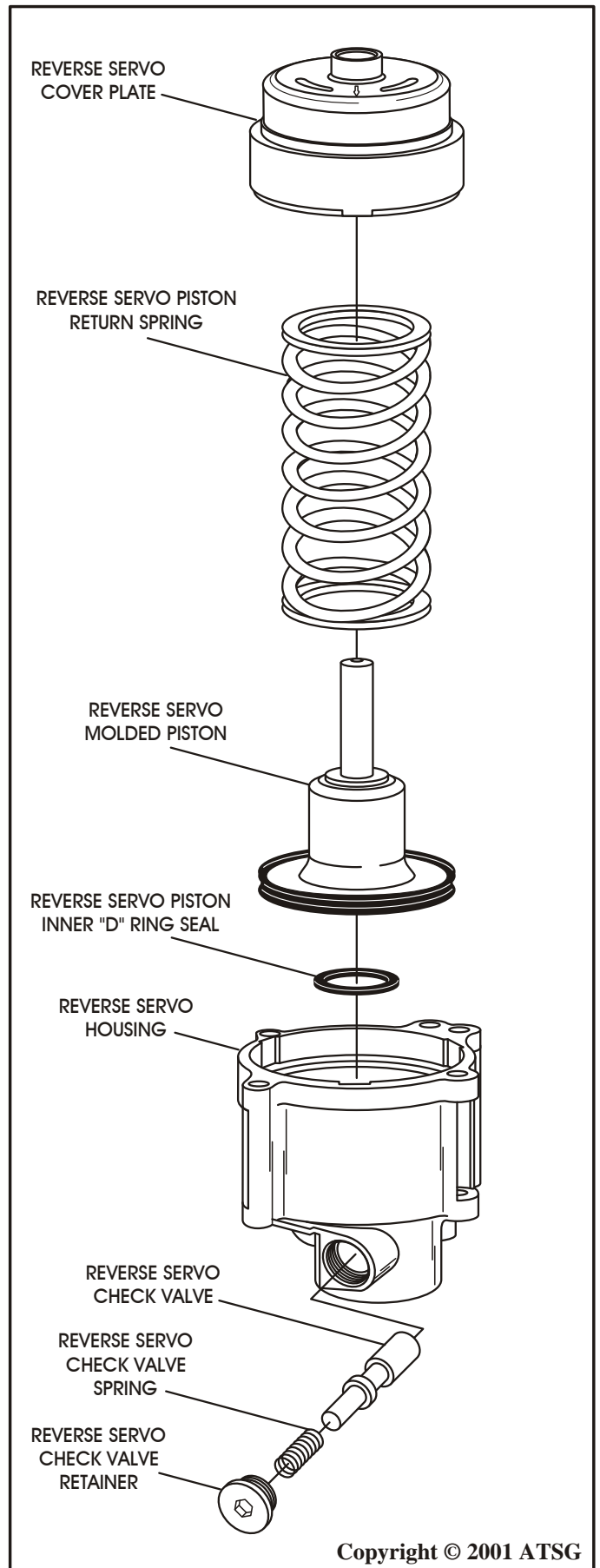

Figure 121

REVERSE SERVO ASSEMBLY (Cont'd)

7. Install new reverse servo piston inner "D" ring seal into the groove in reverse servo housing, as shown in Figure 122, and lubricate with a small amount of Trans-Jel®.
8. Lubricate the reverse servo check valve with Mercon V®, and install in housing, as shown in Figure 123, followed by the spring and the retainer.
9. Lubricate the reverse servo piston with a small amount of Trans-Jel®, and install into reverse servo housing, as shown in Figure 123.
10. Install the reverse servo piston return spring in reverse servo housing (See Figure 124).

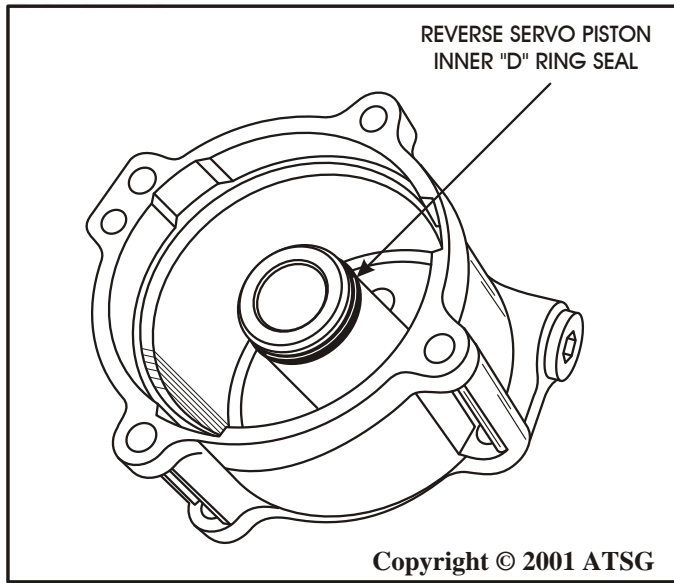

Figure 122

Continued on Page 78

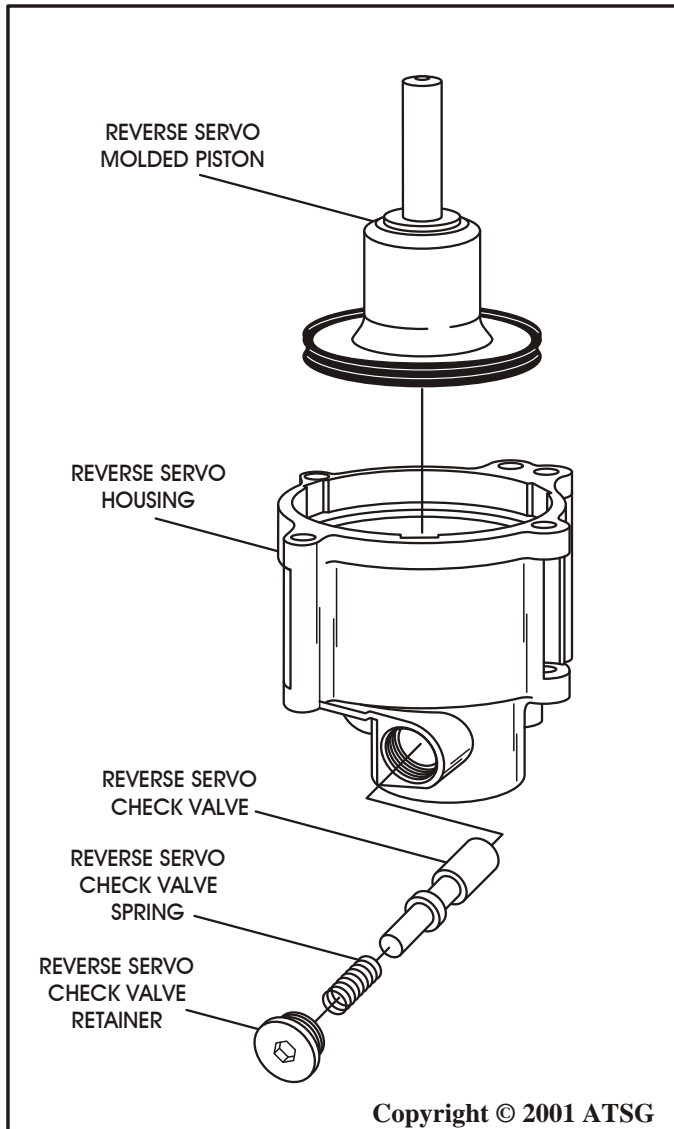

Figure 123

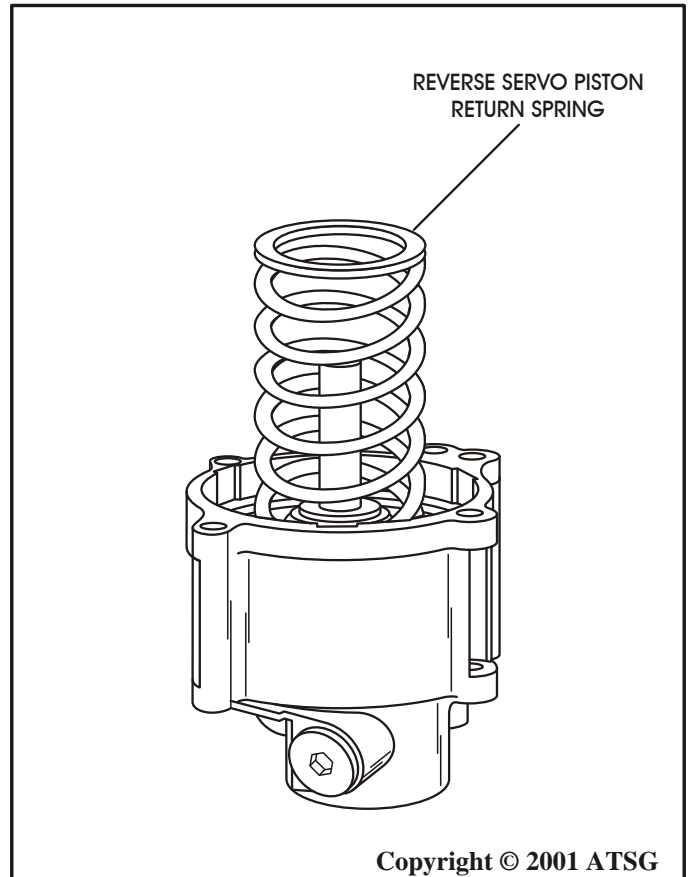

Figure 124

REVERSE SERVO ASSEMBLY (Cont'd)

11. Install the reverse servo cover plate over the return spring, compress the return spring with the cover plate and rotate the tabs into position in the slot, as shown in Figure 125.
12. **Caution:** *The arrow on the cover plate must be aligned evenly between any two slots on the reverse servo housing (See Figure 126).*
13. Set the completed reverse servo assembly aside for the final assembly process.

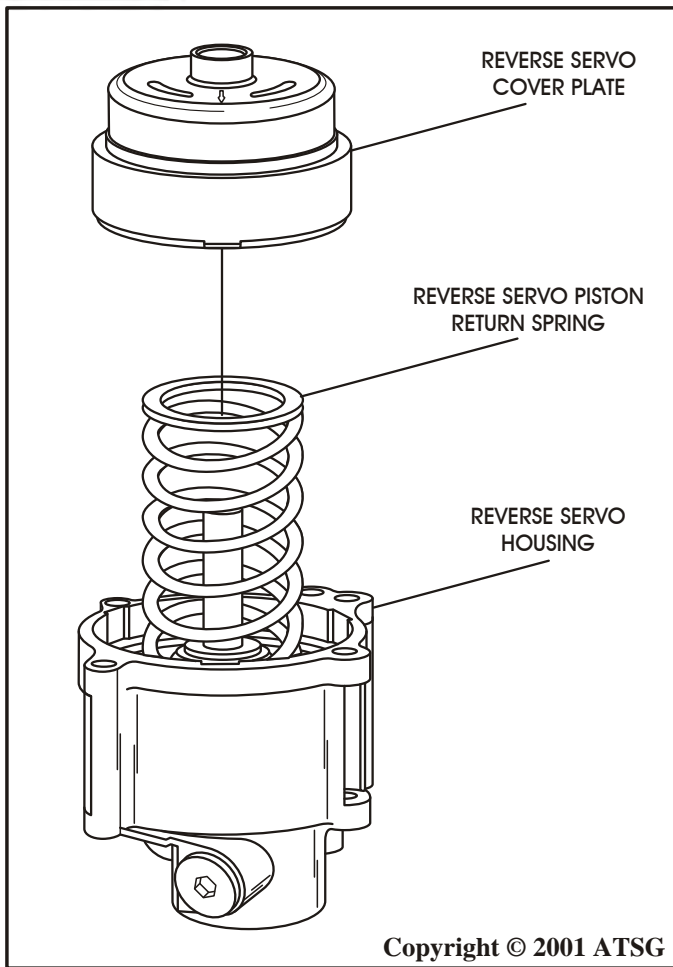

Figure 125

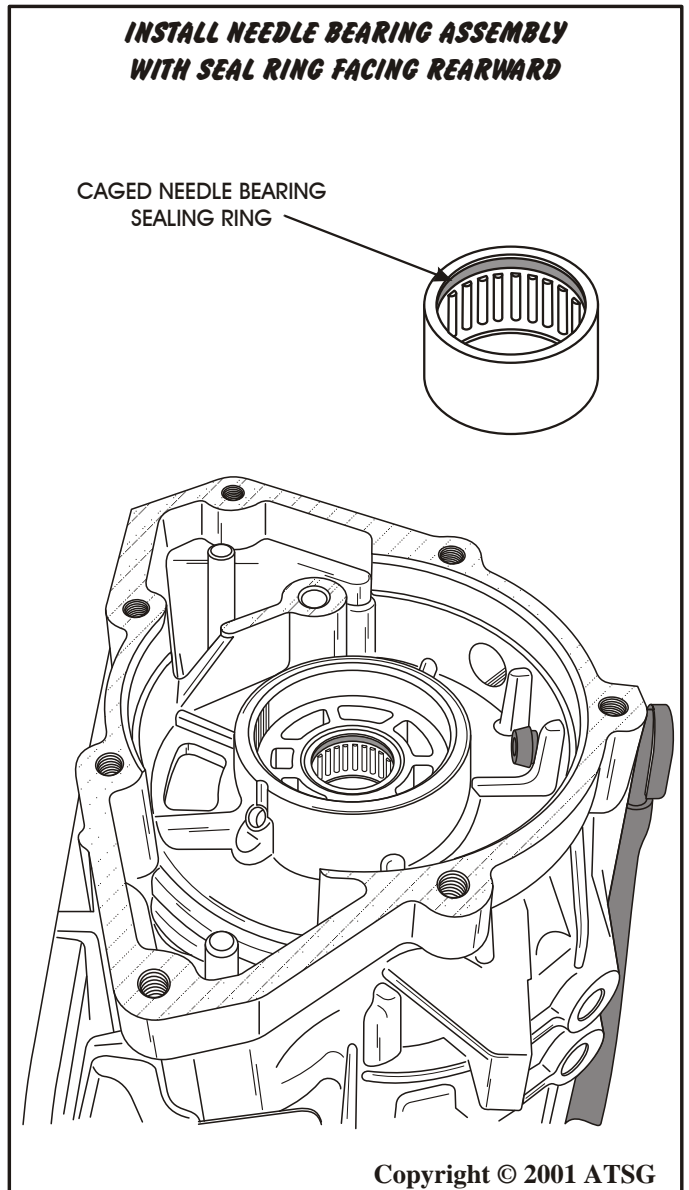

Figure 127

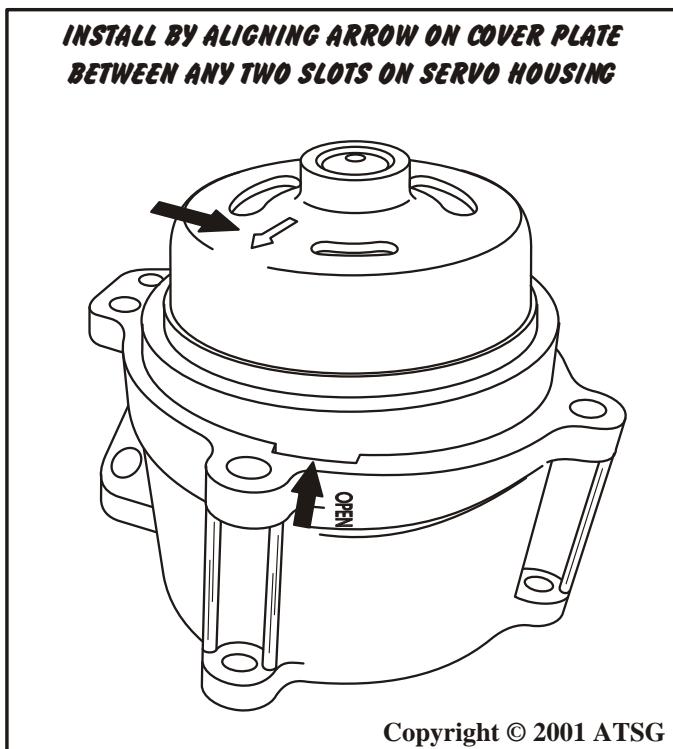

Figure 126

TRANSMISSION CASE ASSEMBLY

1. Inspect the transmission case thoroughly for wear, damaged surfaces, or stripped threads.
2. Inspect the rear case caged needle bearing and replace as necessary using the appropriate tools to remove and install (See Figure 127).

Note: *If replacement is necessary ensure that the sealing ring end of the bearing faces rear, as shown in Figure 127.*

3. Install new manual lever seal into case using the appropriate seal driver (See Figure 128).
4. Install the manual lever, inside detent lever and park rod assembly, manual lever retaining pin and torque nut to 48Nm (35 ft.lb.). Refer to Figure 129.

Note: *Do Not allow the wrench to strike the manual valve inner detent lever pin.*

5. Install the number 11 thrust washer into rear of case, as shown in Figure 130, and retain with a small amount of Trans-Jel®.

Continued on Page 81

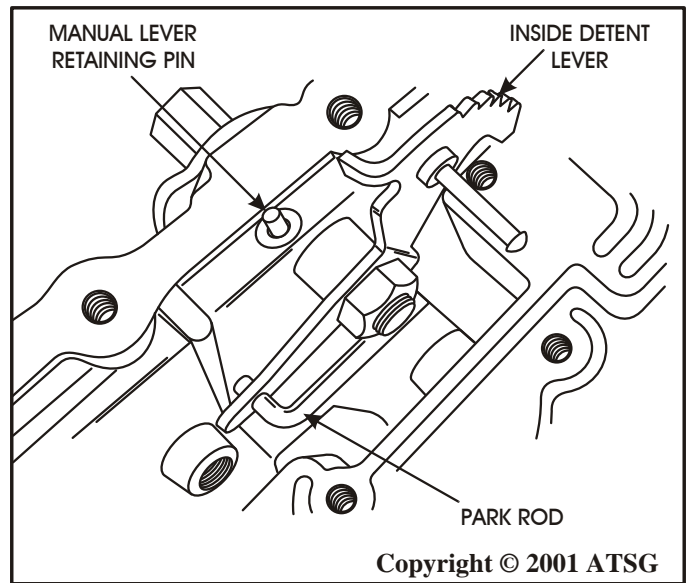

Figure 129

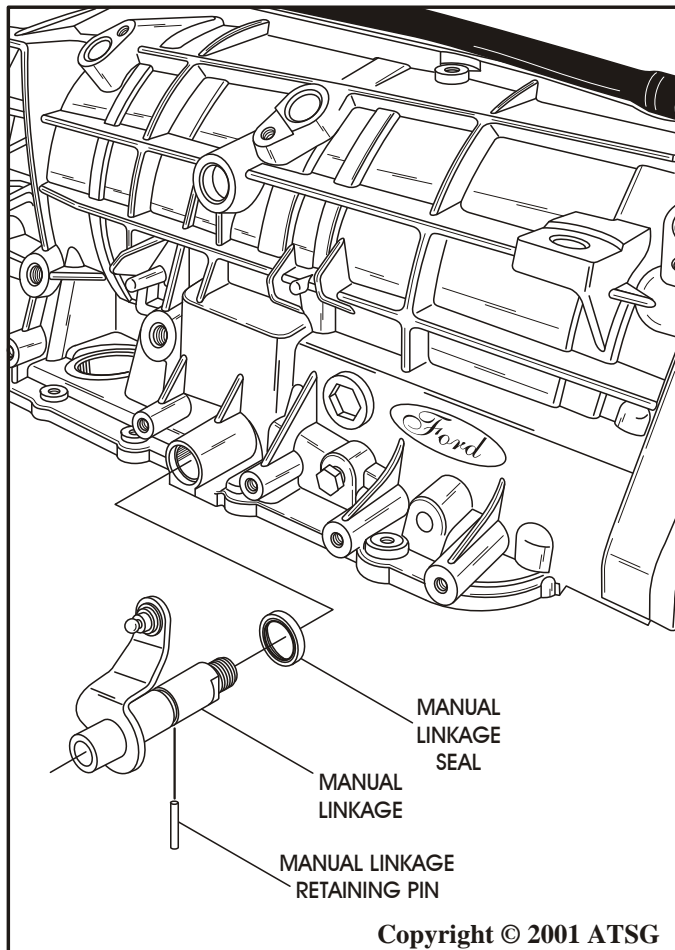

Figure 128

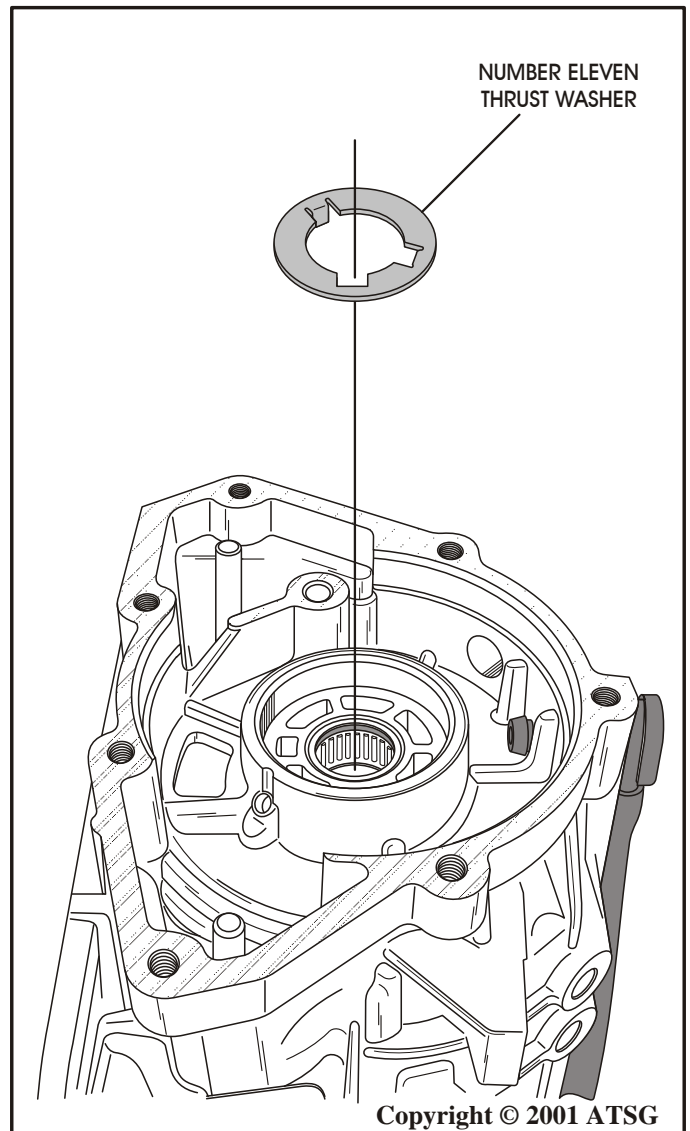

Figure 130

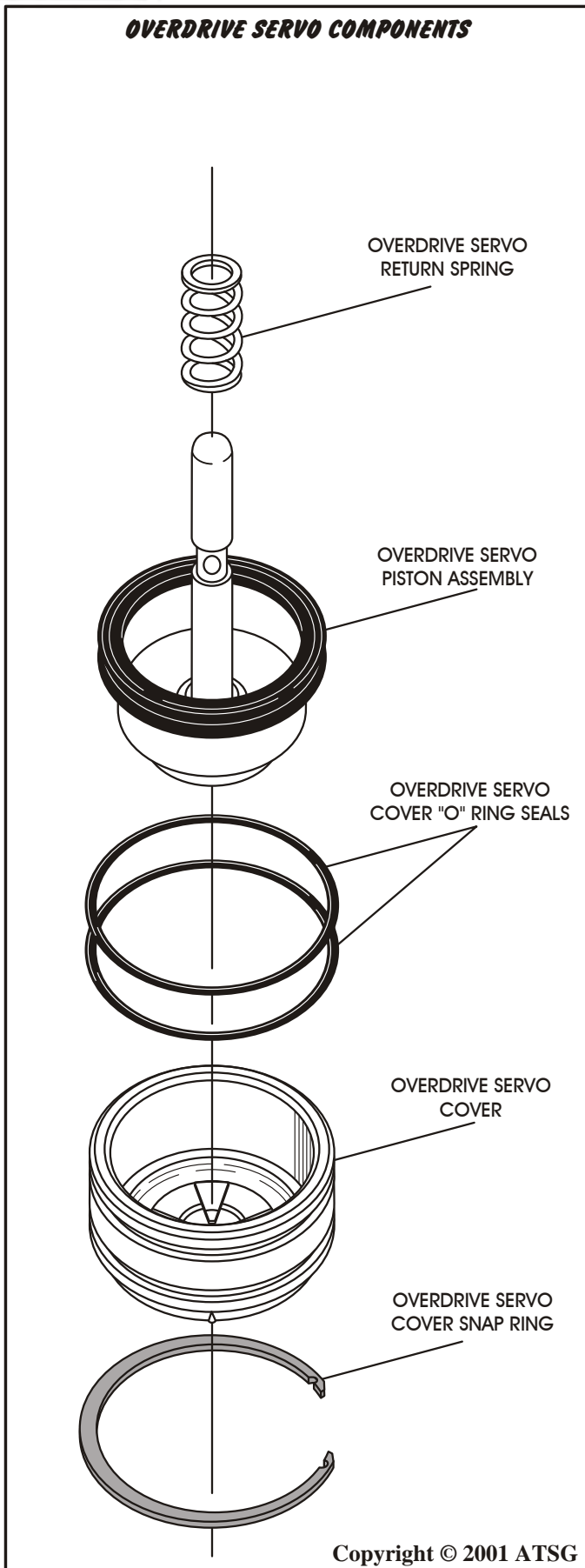

Figure 131

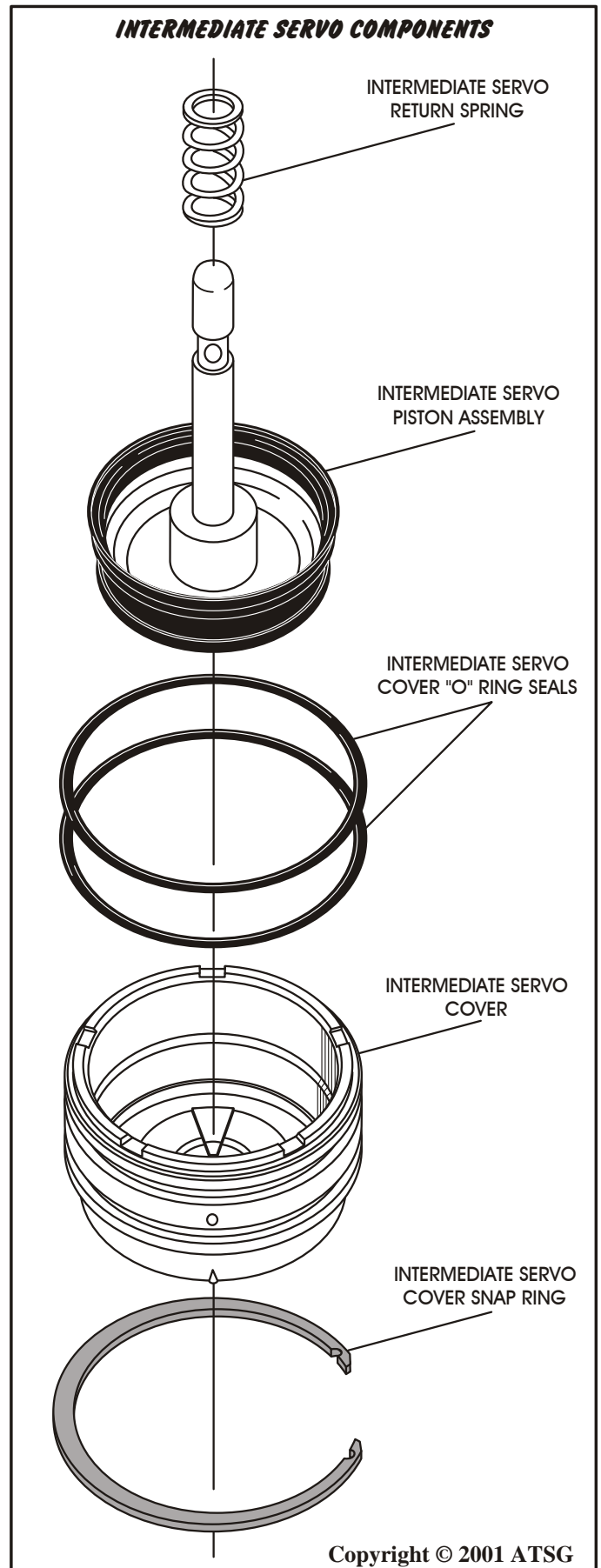

Figure 132

TRANSMISSION CASE ASSEMBLY (Cont'd)

6. Install the transmission case into the fixture and rotate so that pan surface is facing up, as shown in Figure 133.
7. Install new "O" ring seals into the overdrive servo cover grooves, as shown in Figure 131, and lubricate with small amount of Trans-Jel®.
8. Inspect the molded lip seal on the overdrive servo piston for any wear and/or damage and replace piston assembly as necessary.
9. Lubricate molded seal and the overdrive servo case bore with a small amount of Trans-Jel®, and install return spring on back side, as shown in Figure 131.
10. Install the overdrive servo cover assembly into the case bore, compress the return spring and install the snap ring (See Figure 133).
11. Install new "O" ring seals into the intermediate servo cover grooves, as shown in Figure 132, and lubricate with small amount of Trans-Jel®.
12. Inspect the molded lip seals on the intermediate servo piston for any wear and/or damage and replace piston assembly as necessary.
13. Lubricate molded seals and both intermediate servo cover bores with a small amount of Trans-Jel®.
14. Install the intermediate servo piston into the cover with a twisting motion, until it is fully seated (See Figure 132).
15. Install the servo return spring over the pin on the back side as shown in Figure 132.
16. Install the intermediate servo assembly into the case bore, compress the return spring and install the snap ring (See Figure 133).
17. With these two servo assemblies installed, you are now ready for the final assembly process.

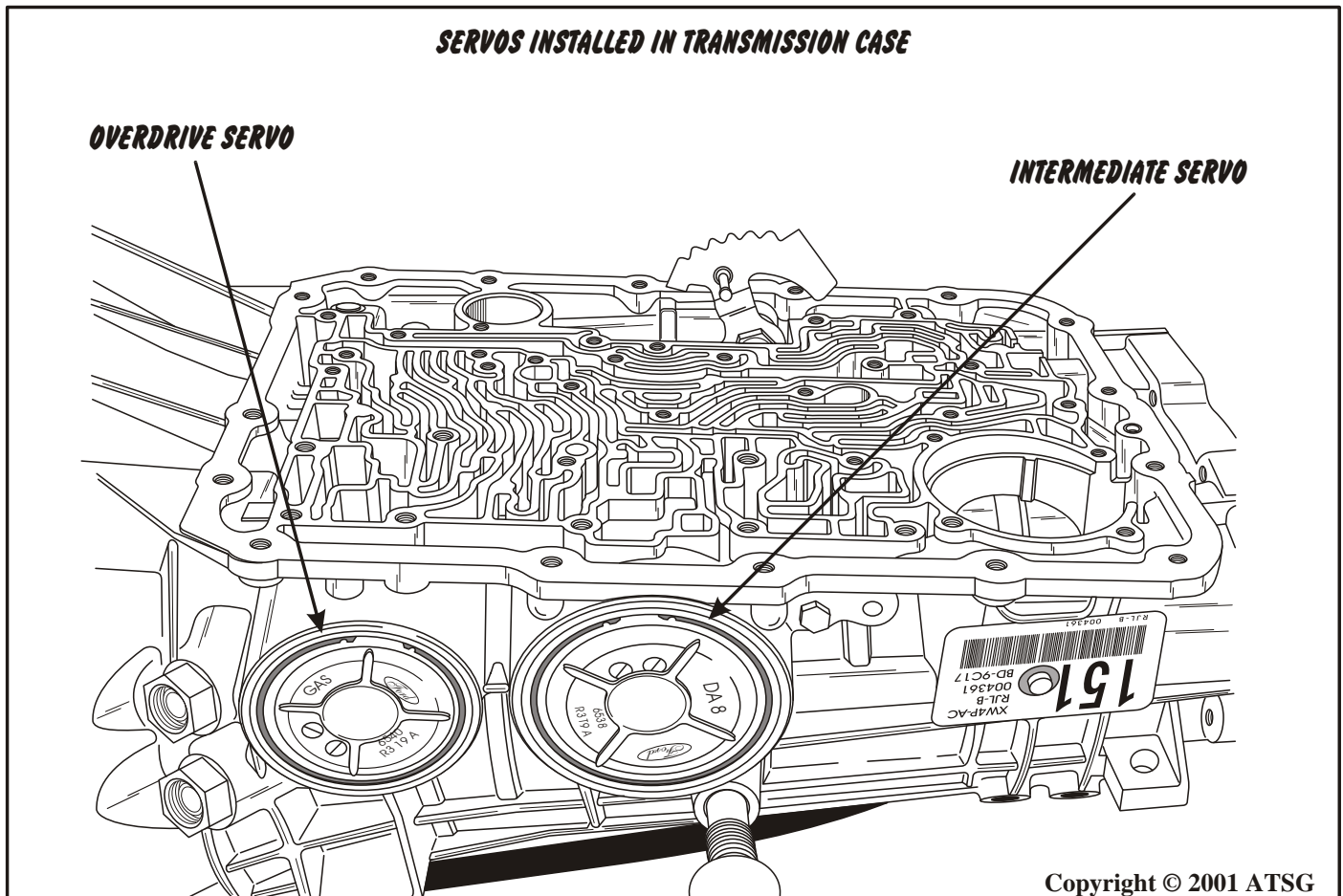

Figure 133

EXTENSION HOUSING AND PARKING PAWL

1. Inspect the extension housing caged needle bearing for any wear and/or damage.
2. Replace caged needle bearing as necessary, using the appropriate puller and installer. Refer to Figure 134 as a guide.
3. Install a new extension housing yoke seal, as shown in Figure 134, using the appropriate seal driver.
4. Turn the extension housing over to install the parking pawl components (See Figure 135).
5. Install the parking pawl return spring onto the extension housing, with the leg of the return spring in front of housing shoulder, as shown in Figure 136.
6. Install the parking pawl pivot pin through the center of return spring, as shown in Figure 137.
7. Install the parking pawl over the pivot pin and hook the return spring on the parking pawl, as shown in Figure 138.
8. Set the completed extension housing aside for the final assembly process.

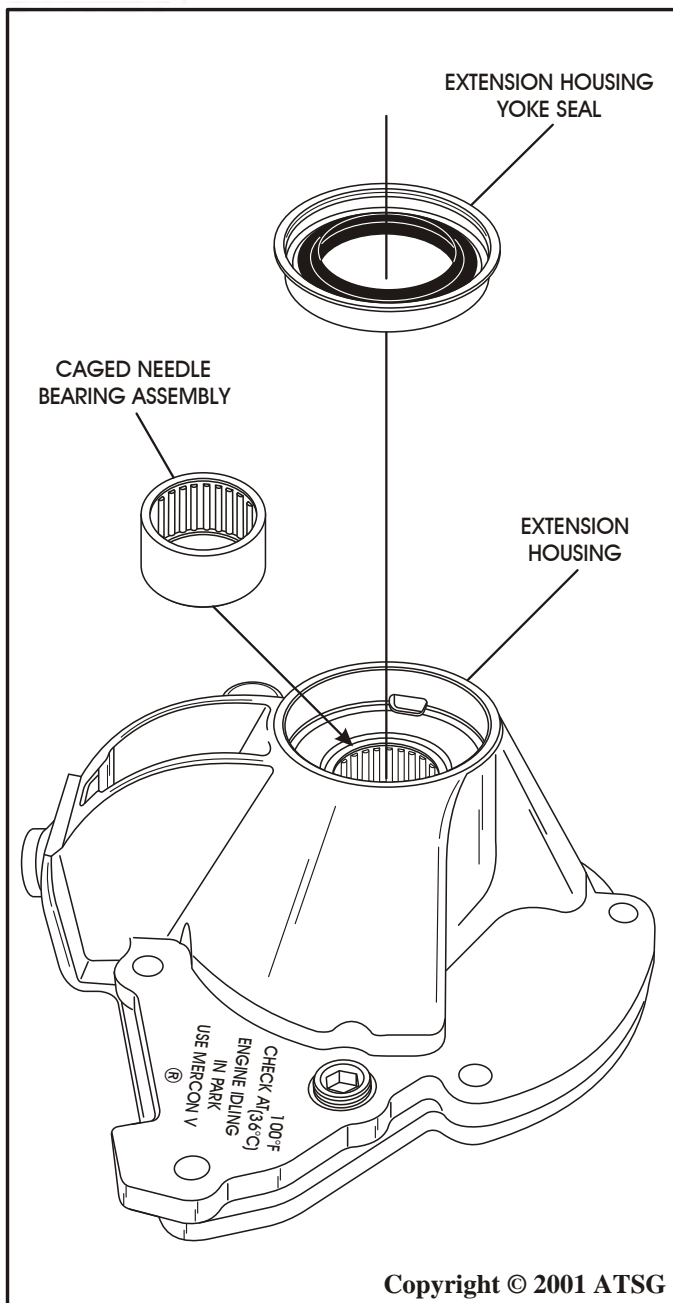

Figure 134

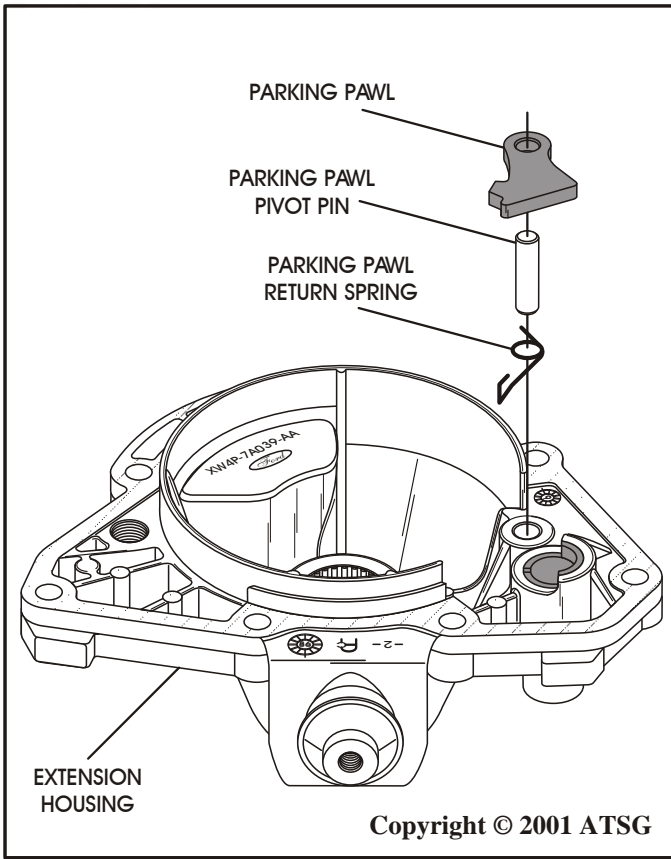

Figure 135

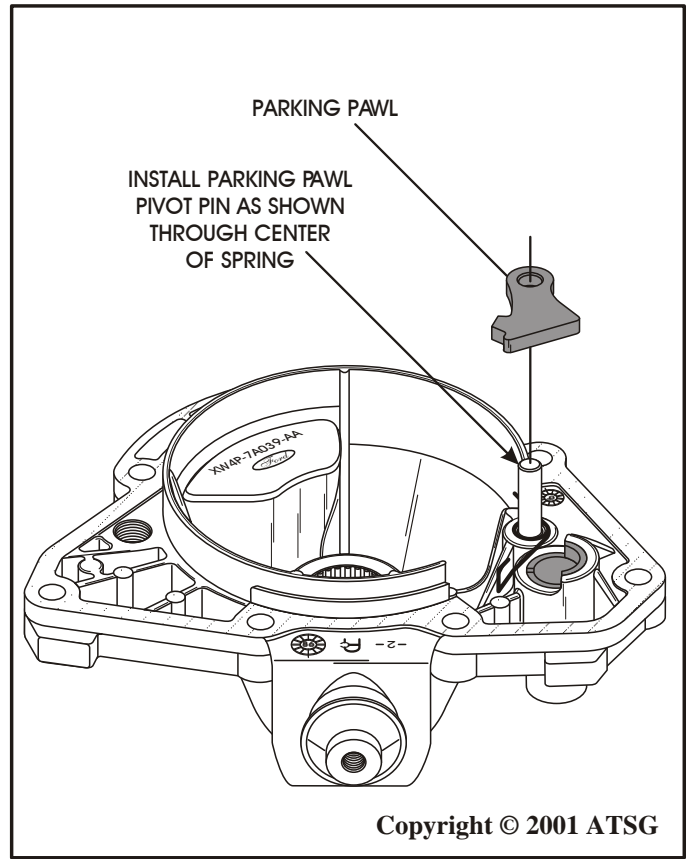

Figure 137

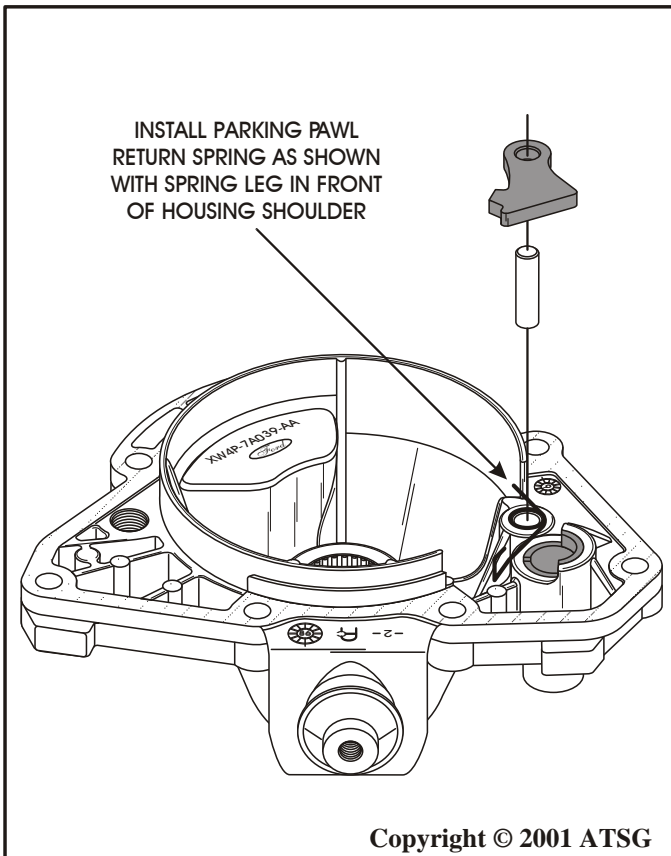

Figure 136

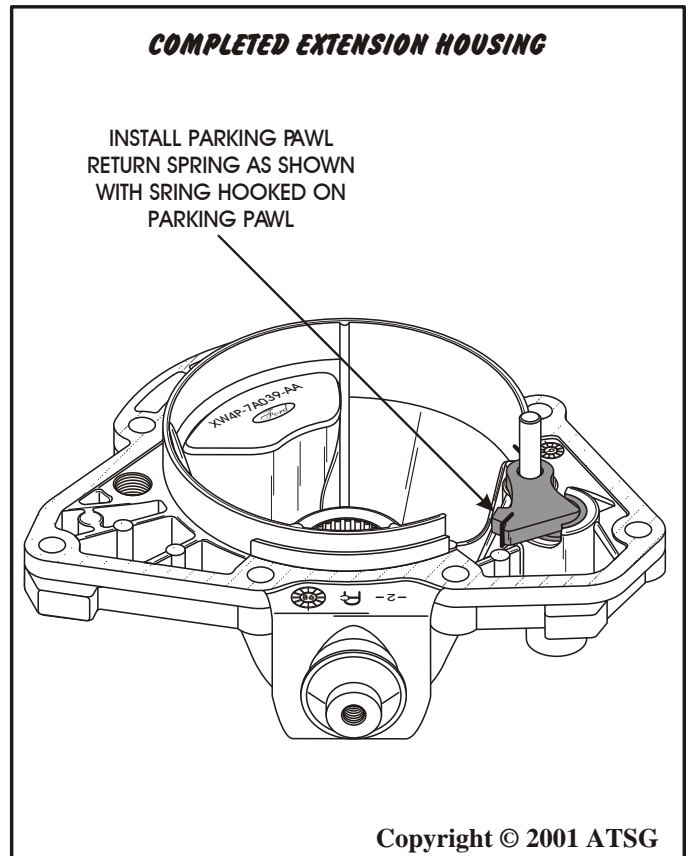
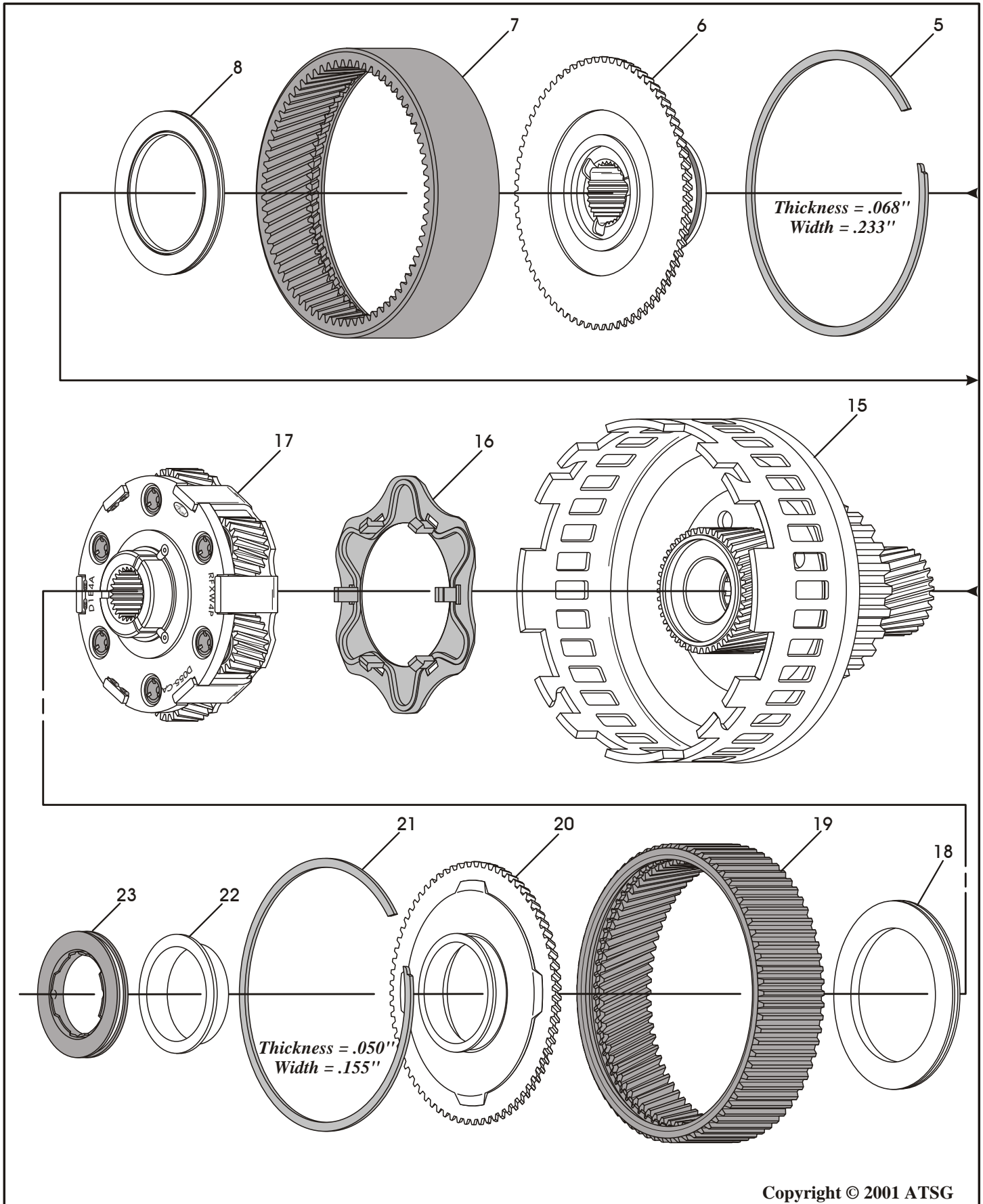
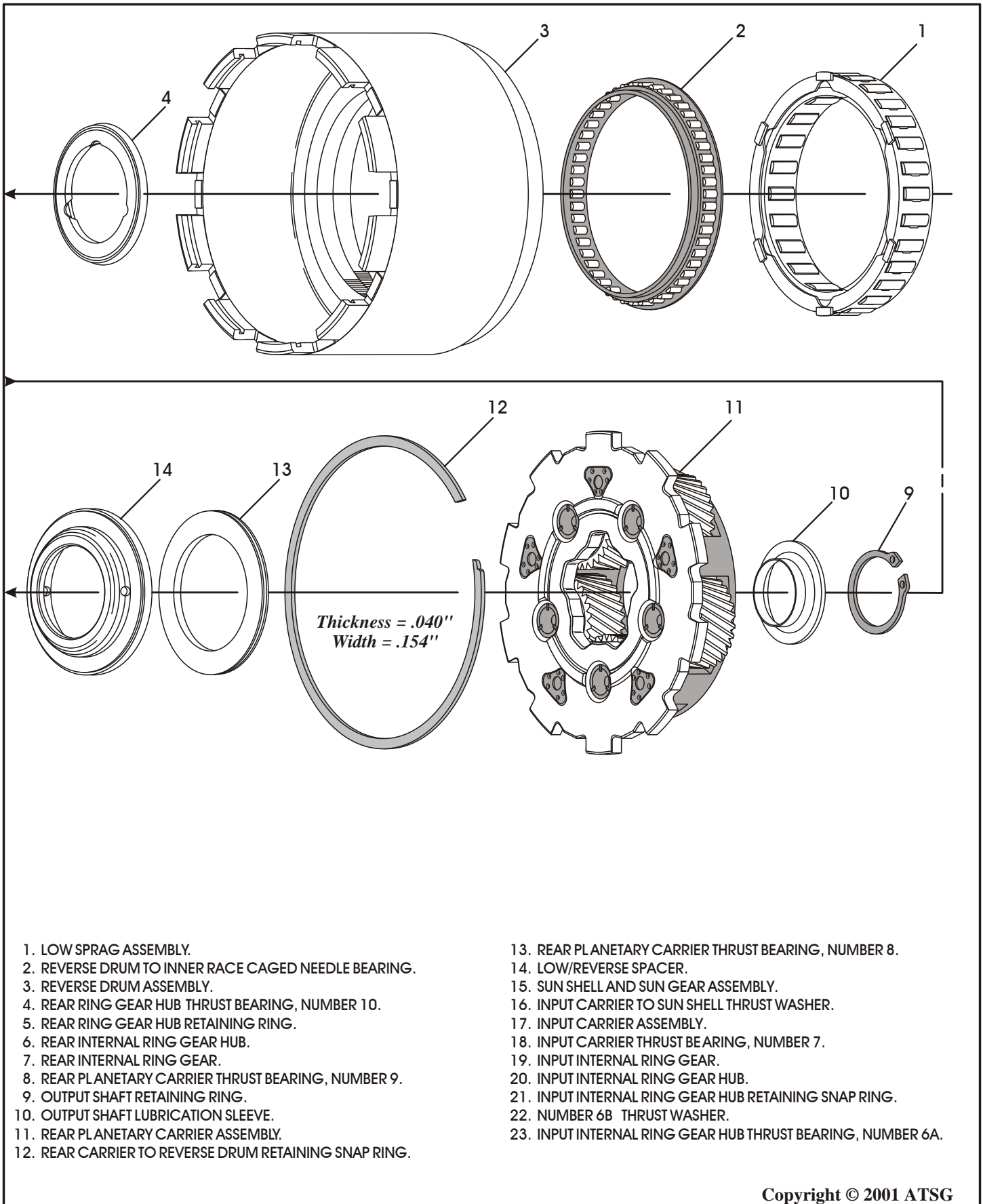

Figure 138



Copyright © 2001 ATSG

Figure 139



Copyright © 2001 ATSG

Figure 140

FINAL TRANSMISSION ASSEMBLY

INTERNAL COMPONENTS

1. Rotate transmission in fixture so that front of case is facing up, as shown in Figure 141.
2. Install the reverse band into transmission, as shown in Figure 141, ensuring that it engages on the band anchor lugs in the case.
3. Compress the reverse band enough to engage the reverse band lever into the notches in the reverse band.
4. Install reverse drum and low sprag assembly into the reverse band, as shown in Figure 141, by rotating in a clock-wise direction.
5. Install rear planetary ring gear thrust bearing (Number 10) into the case in direction shown in Figure 141.
6. Install the pre-assembled rear planetary ring gear that has the seal ring with the notches in it, as shown in Figure 142.

Continued on Page 87

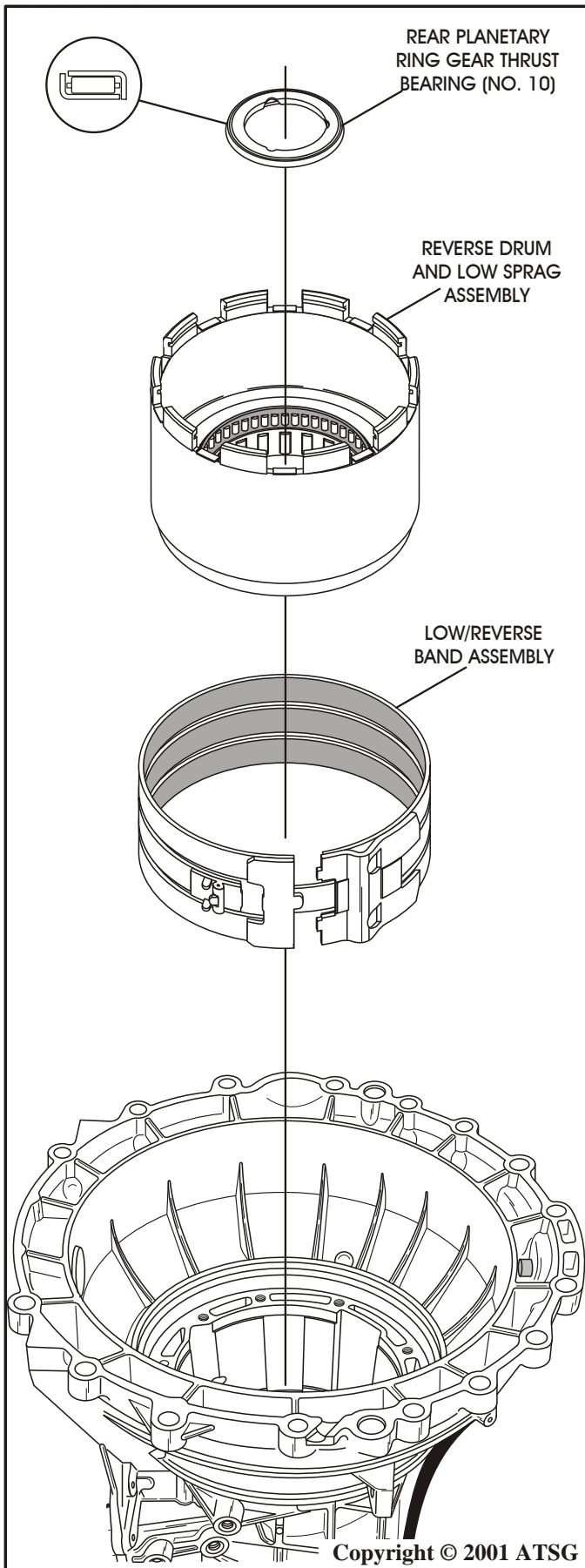

Figure 141

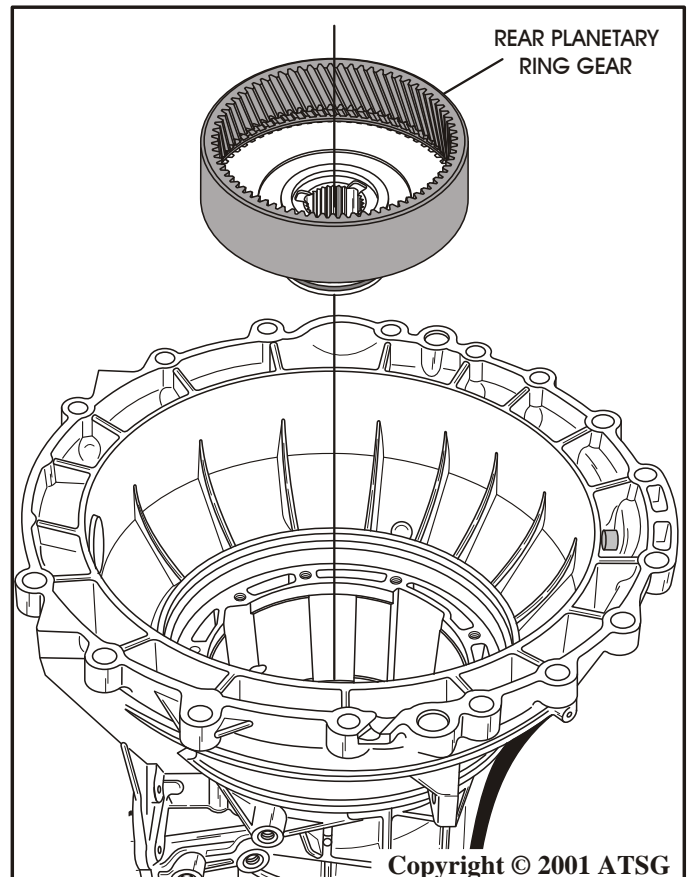

Figure 142

INTERNAL COMPONENTS (Cont'd)

7. Rotate transmission so that the pan surface is facing up, as shown in Figure 143.
8. Ensure the number 11 thrust washer is still in place in rear of case, as shown in Figure 143.
9. Install the parking gear into transmission, as shown in Figure 143.
10. Install the output shaft into transmission in the direction shown in Figure 144, by rotating so that it engages in the parking gear splines and the rear planetary ring gear splines.

Continued on Page 88

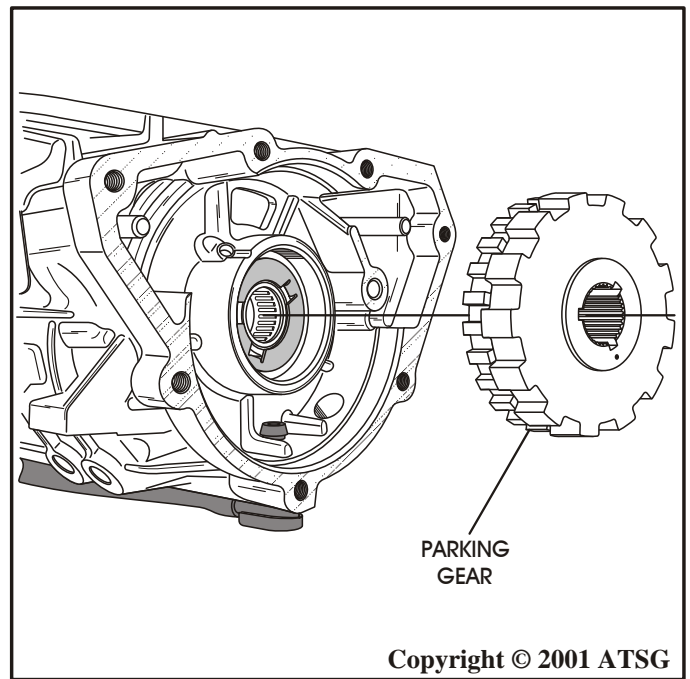

Figure 143

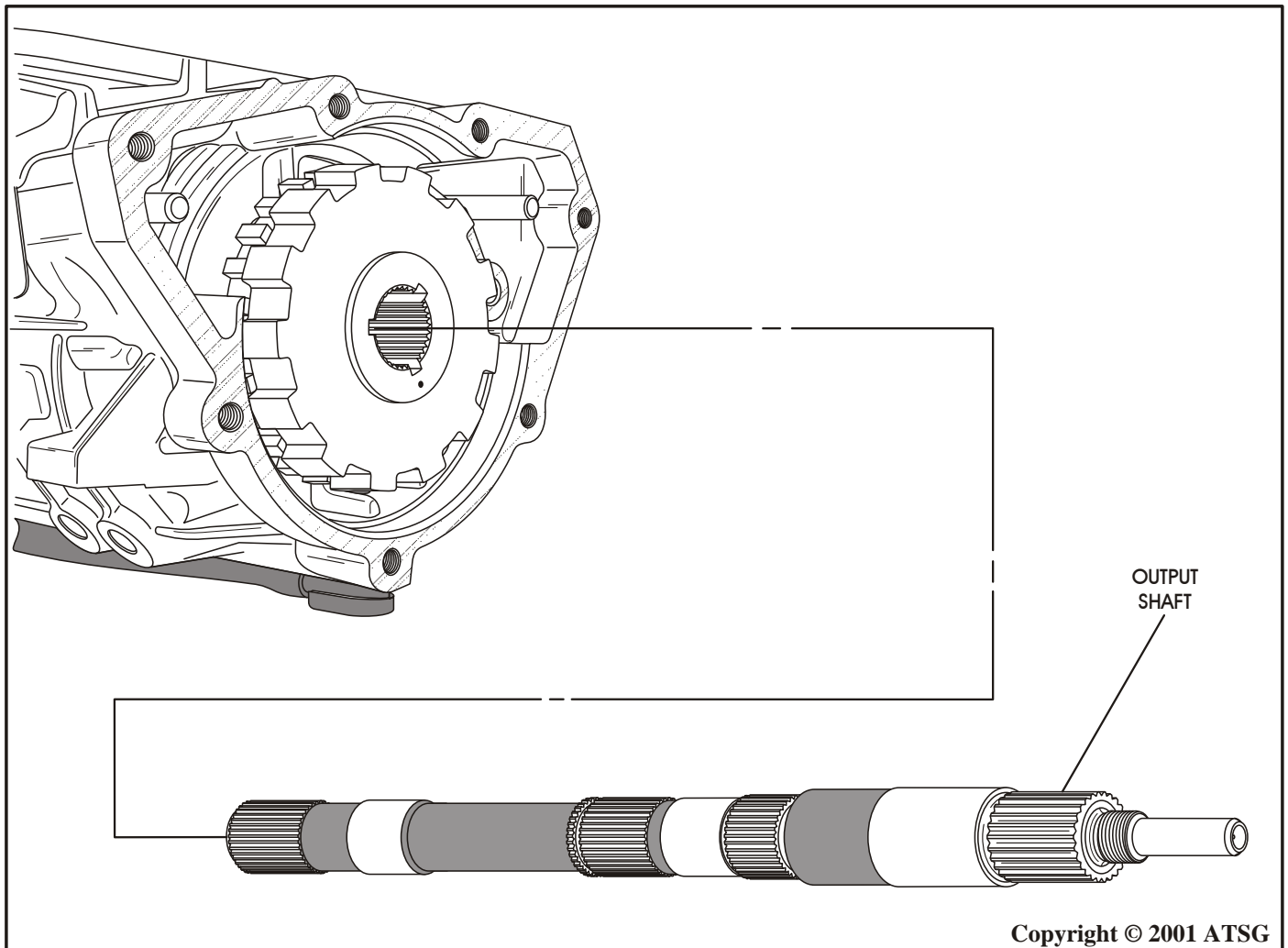

Figure 144

INTERNAL COMPONENTS (Cont'd)

11. With the pan rail still facing up, install output shaft snap ring into the groove in the output shaft and ensure that it is fully seated. Refer to Figure 145.

Caution: *This must be done with pan rail facing up, so that output shaft does not fall out and possibly create injury.*

12. Now the transmission can be rotated so that bell is facing up, as shown in Figure 145.

13. Install the plastic rear lube dam into rear ring gear in the direction shown in Figure 145.

14. Install the rear planetary thrust bearing (No 9) into rear ring gear in the direction shown in Figure 146, and retain with a small amount of Trans-Jel®.

15. Install the rear planetary carrier assembly, as shown in Figure 146, by rotating into position.

16. Install the rear planetary snap ring into groove in reverse drum and ensure it is fully seated. (See Figure 146). **Note:** *Reverse drum will must be lifted up to install snap ring.*

Continued on Page 89

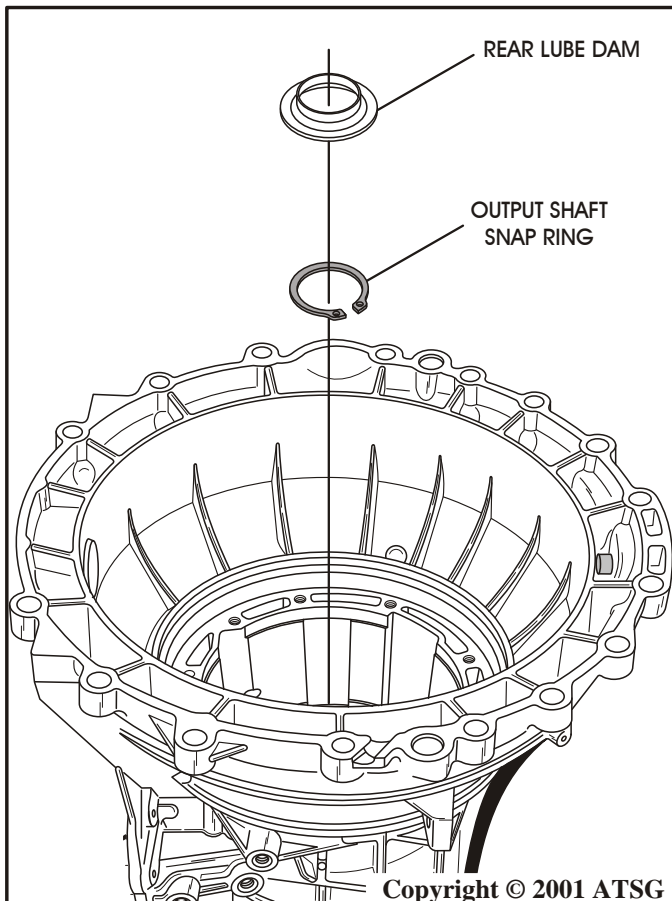
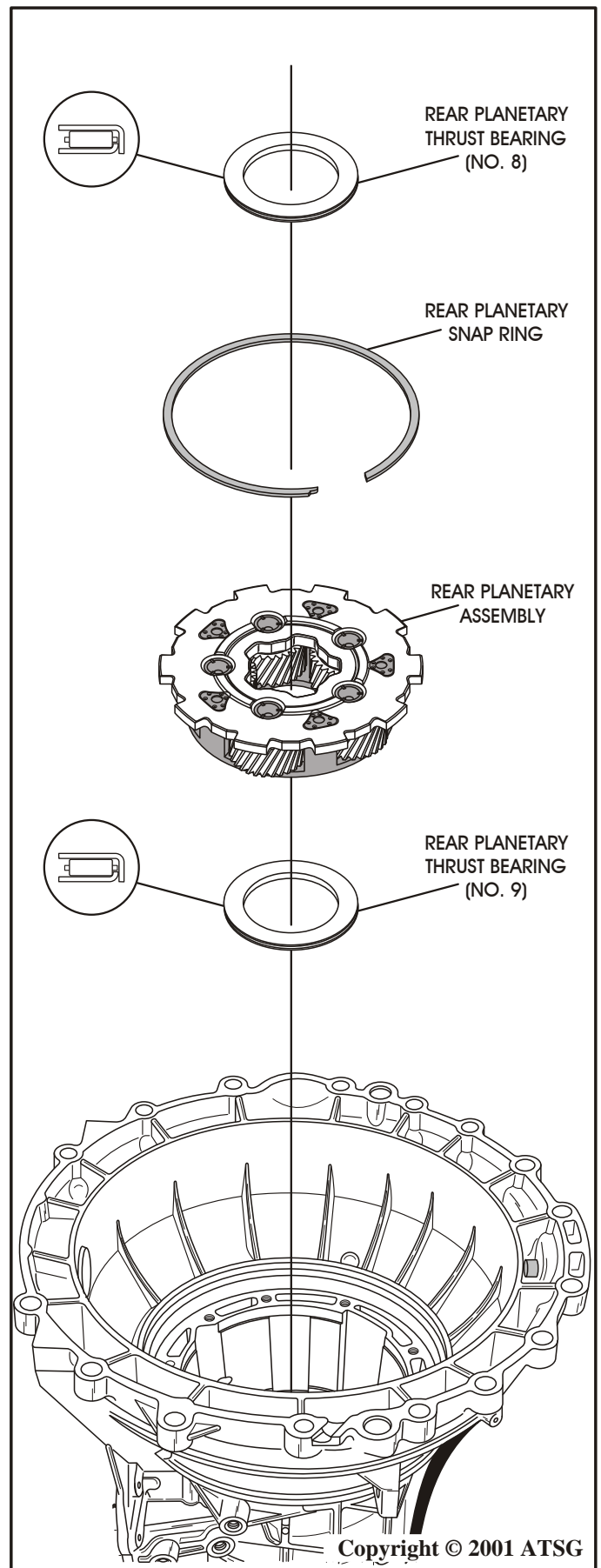

INTERNAL COMPONENTS (Cont'd)

17. Install the rear planetary thrust bearing (No 8) onto rear planetary in the direction shown in Figure 146, and retain with a small amount of Trans-Jel®.
18. Install the low/reverse spacer on top of the rear planetary thrust bearing (No 8), in the direction shown in Figure 147, and retain with a small amount of Trans-Jel®.
19. Install the pre-assembled intermediate clutch housing assembly into the transmission case, as shown in Figure 148, and ensure it is fully seated.
20. Install the pre-assembled intermediate piston retainer assembly into the transmission case, as shown in Figure 148.

Continued on Page 90

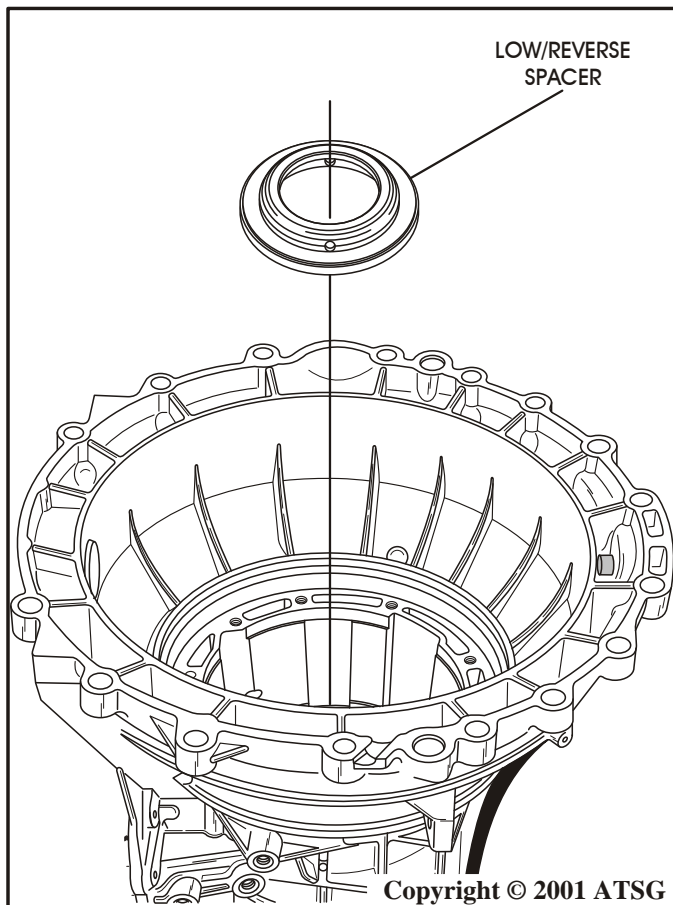

Figure 147

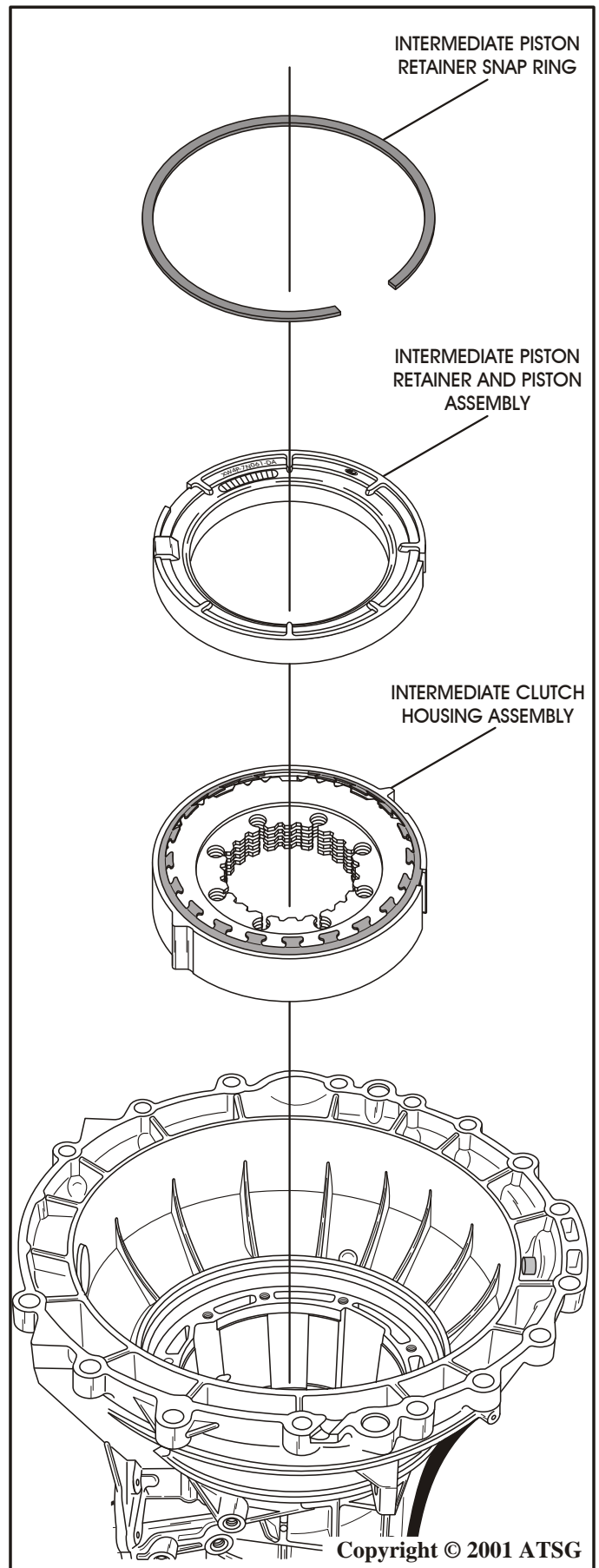

Figure 148

INTERNAL COMPONENTS (Cont'd)

21. Install the special tool, as shown in Figure 149, to compress the intermediate clutch bellville spring.
22. Compress the bellville return spring and install retaining snap ring for the intermediate clutch piston retainer (See Figure 148).
Caution: Ford recommends replacing this snap ring on all rebuilds.
23. Remove the compression tool.
24. Install the pre-assembled input shell and sprag assembly, as shown in Figure 150, by rotating into position.
25. Install the pre-assembled forward planetary assembly, as shown in Figure 150, by rotating into position.
Caution: Ensure that snapped in thrust washer is still in position.
26. Install forward planetary thrust bearing (No 7), in the direction shown in Figure 150, and retain with a small amount of Trans-Jel®.
27. Install the forward ring gear and hub, as shown in Figure 150, by rotating into position.
28. Install forward clutch thrust washer (No. 6B), as shown in Figure 150.

Continued on Page 91

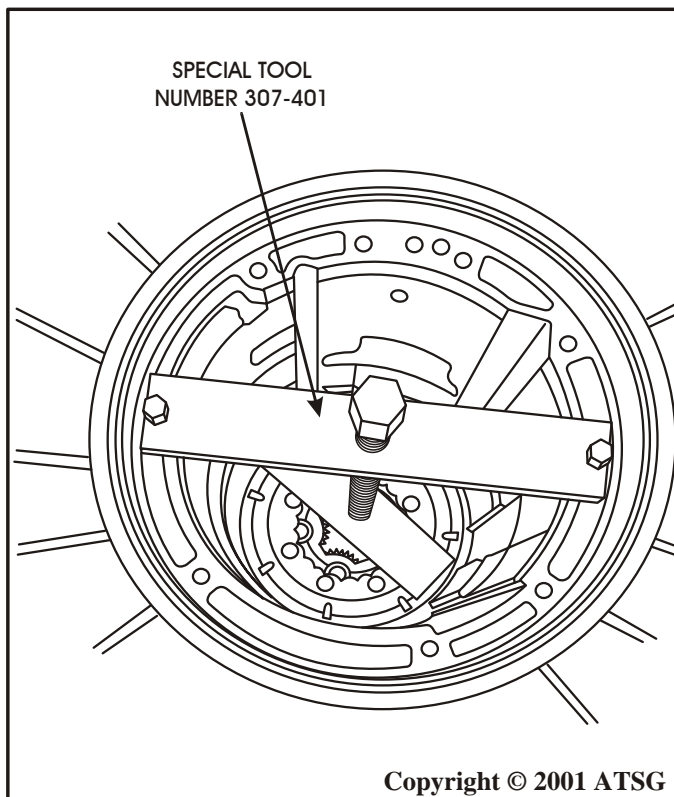

Figure 149

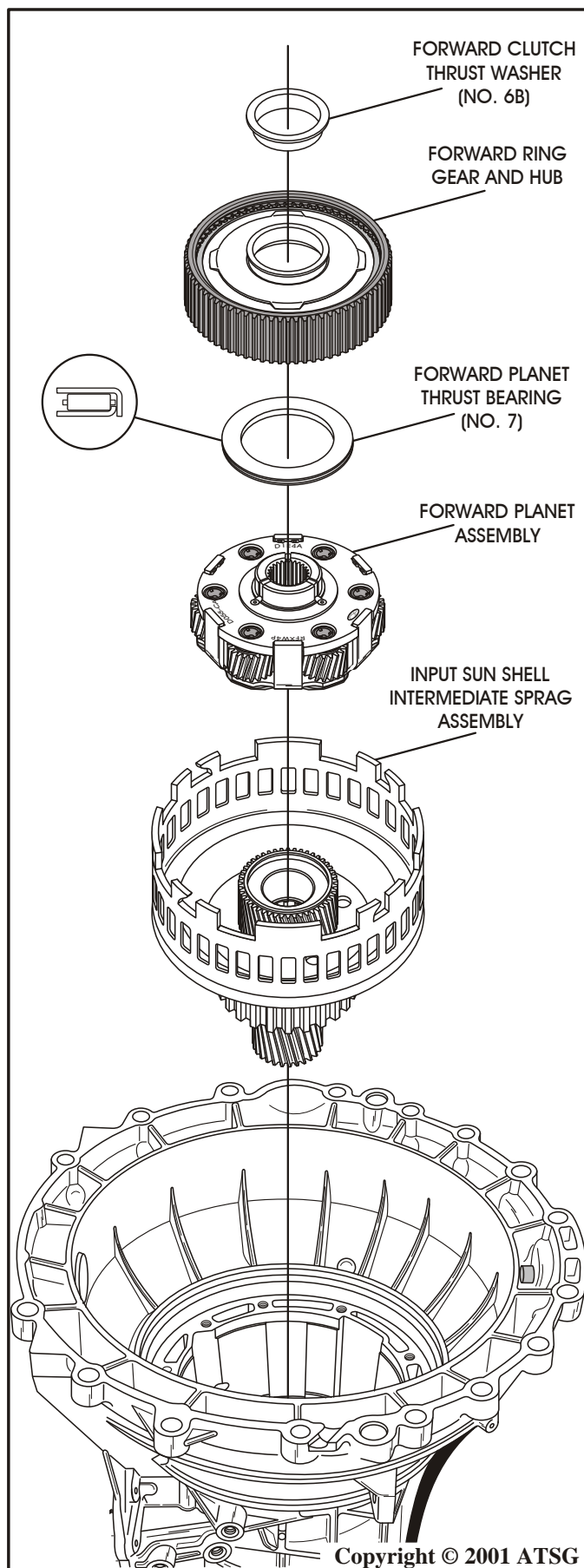

Figure 150

INTERNAL COMPONENTS (Cont'd)

29. Install forward clutch thrust bearing (No 6A) onto the back side of pre-assembled forward clutch drum, in direction shown in Figure 151, and retain with a small amount of Trans-Jel®.
30. Install forward clutch thrust bearing (No 5) on front side of forward clutch drum, in direction shown in Figure 151, and retain with a small amount of Trans-Jel®.
31. Install forward clutch housing, with bearings, as an assembly, as shown in Figure 151.
32. **Caution: The thrust bearing (No 4) that goes between direct clutch drum and center support is "Selective" and a measurement must be made before installation.**
33. Assemble the selective bearing, direct clutch housing and center support, **on the bench**, as shown in Figure 152.
34. Measure with a dial caliper through the speed sensor hole down to the surface of the direct clutch housing, as shown in Figure 152, and **record this as dimension "A"**.

Continued on Page 93

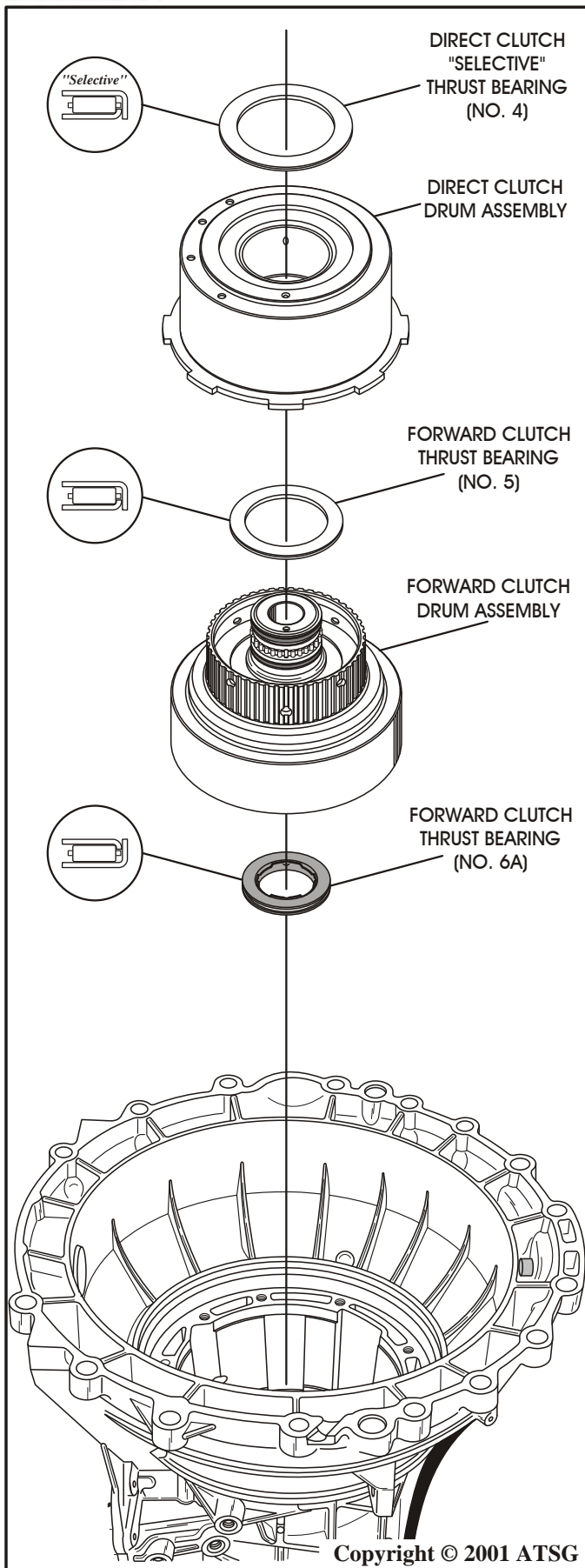

Figure 151

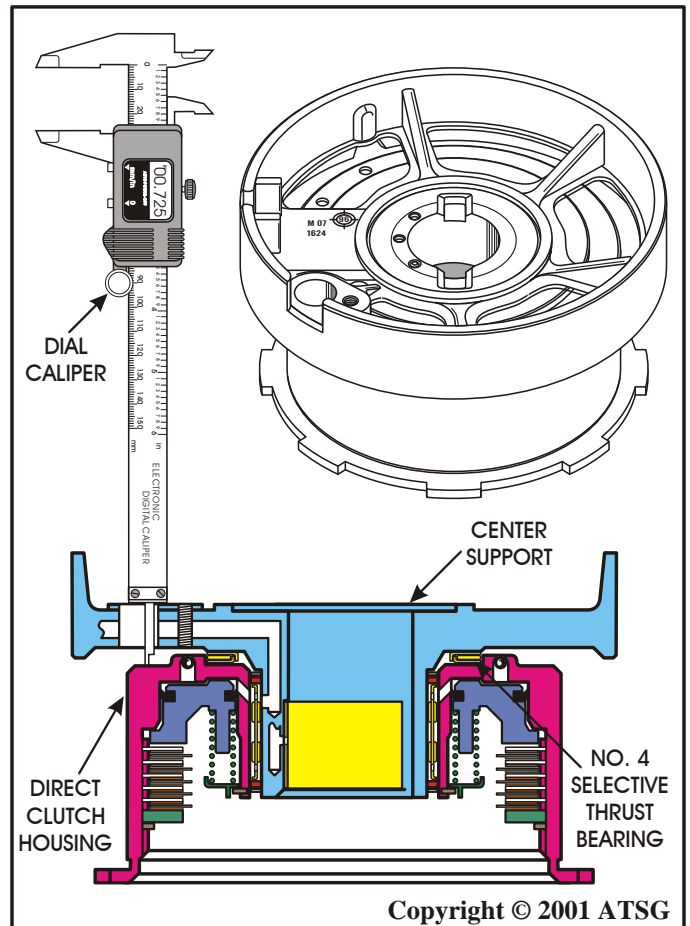

Figure 152

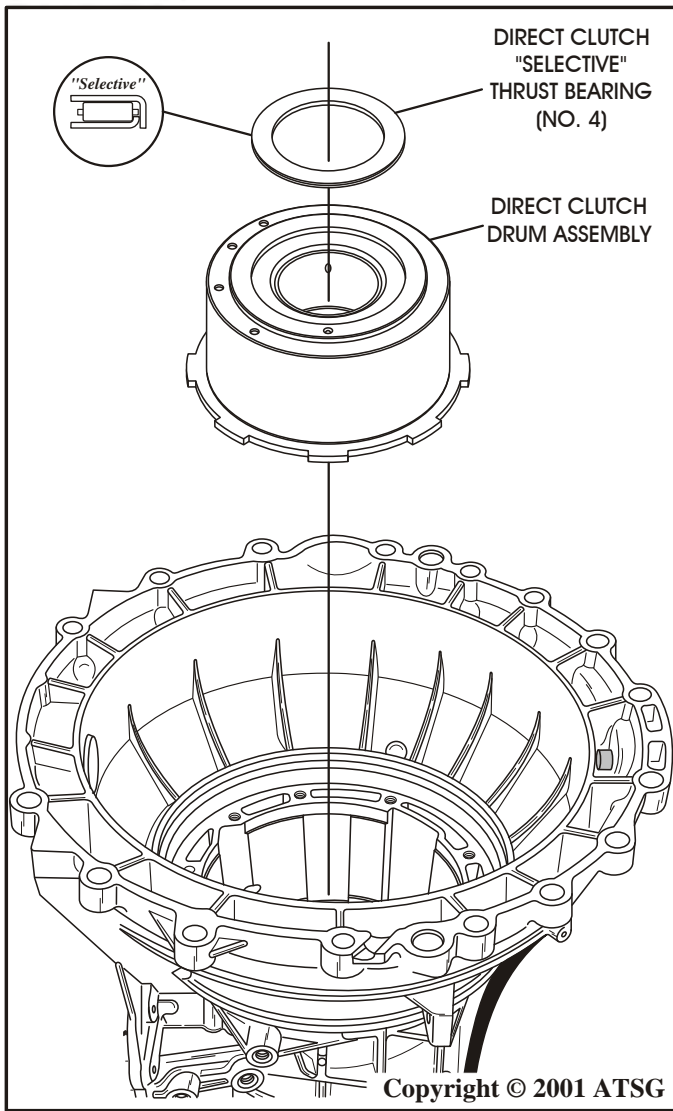

Figure 153

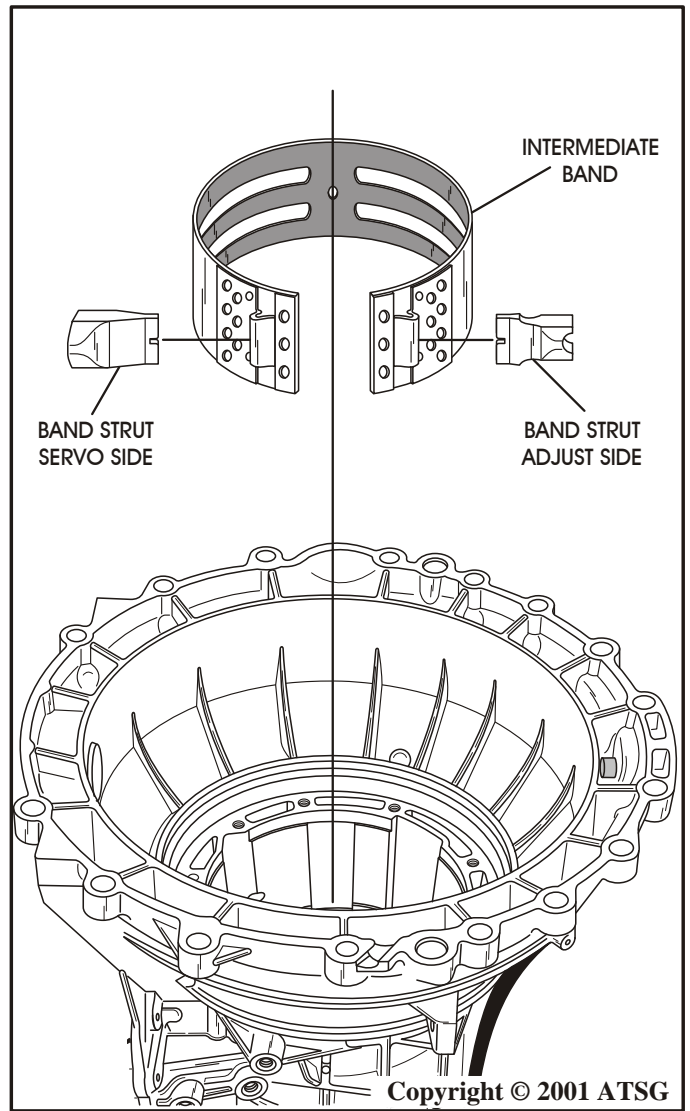

Figure 154

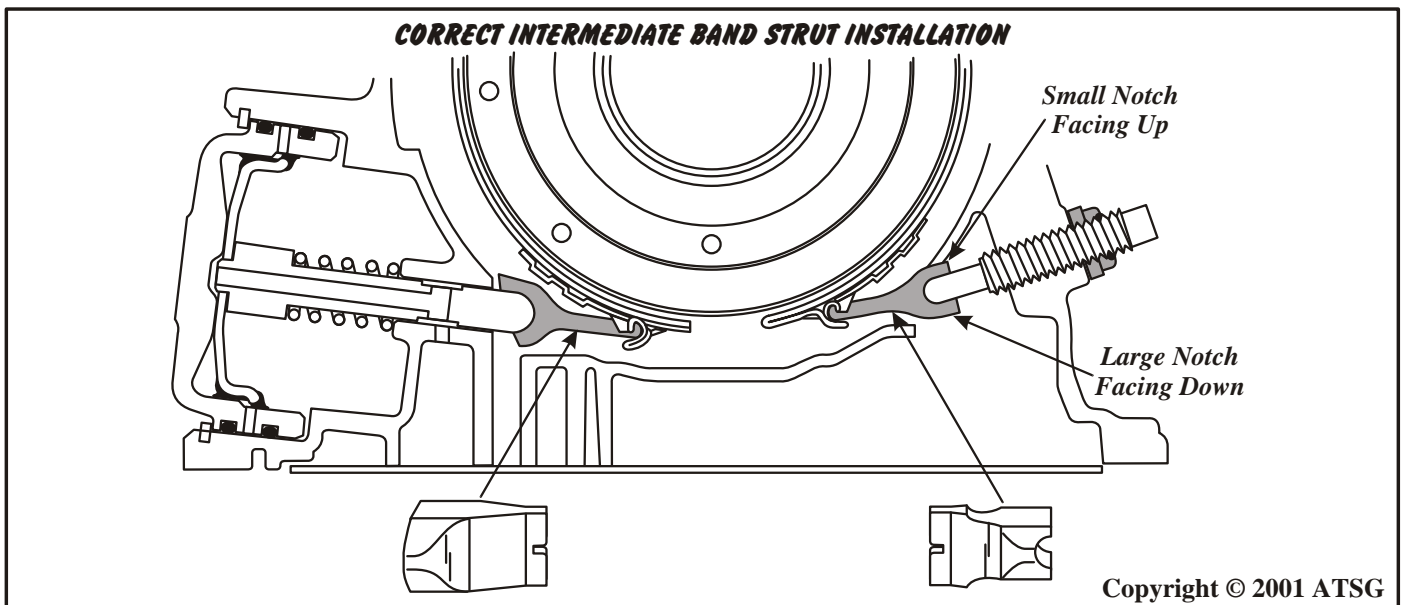

Figure 155

INTERNAL COMPONENTS (Cont'd)

35. After you have recorded the first measurement, install the pre-assembled direct clutch housing, as shown in Figure 153, by rotating back and forth until fully seated.
36. Install the number 4 thrust bearing in position on the direct clutch drum, in the direction that is shown in Figure 153.
37. Install the intermediate band into transmission and around the direct clutch housing, as shown in Figure 154.

INTERNAL COMPONENTS (Cont'd)

38. Install the intermediate band struts on each side of the band, *exactly* as shown in Figure 155.
Caution: *The anchor or adjustment side must have strut installed that is illustrated in Figure 155 and must be installed with the small notch facing the top of transmission.*
The apply or servo side must also be installed, as shown in Figure 155.
39. Install the center support assembly, ensuring that you align the hole for the center support with the proper passage (See Figure 156).
40. Loosely install the center support retaining bolt as shown in Figure 157.

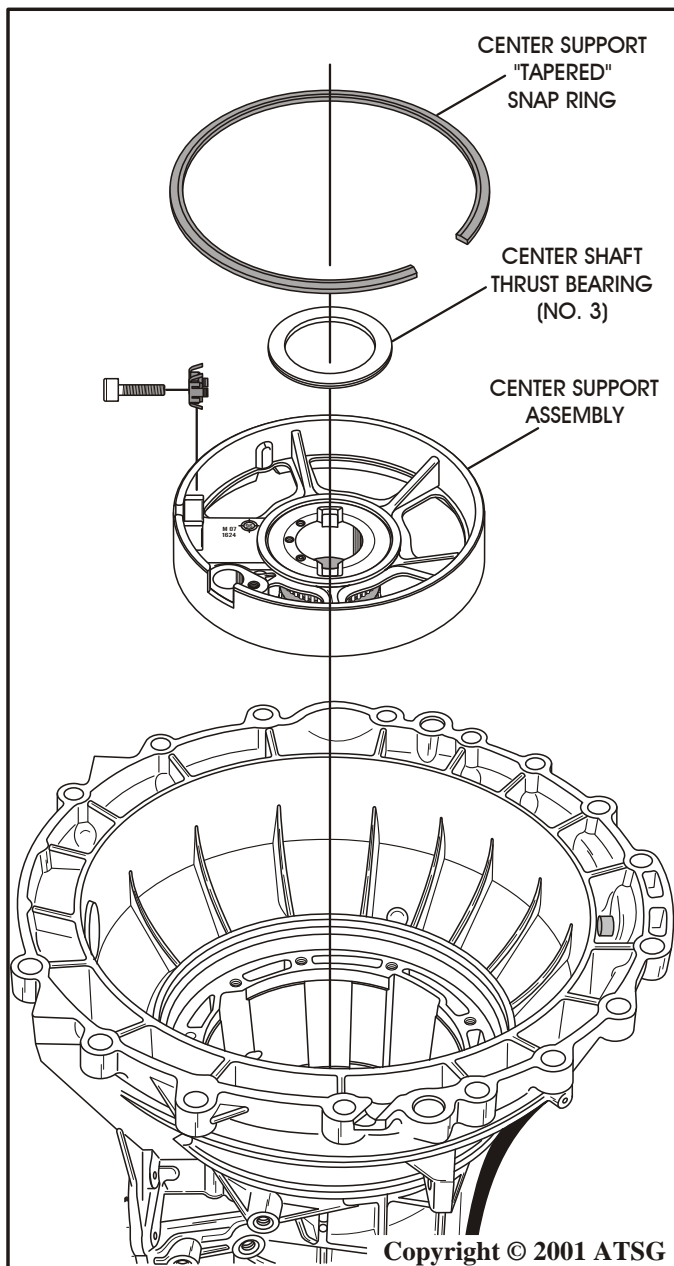

Figure 156

Continued on Page 94

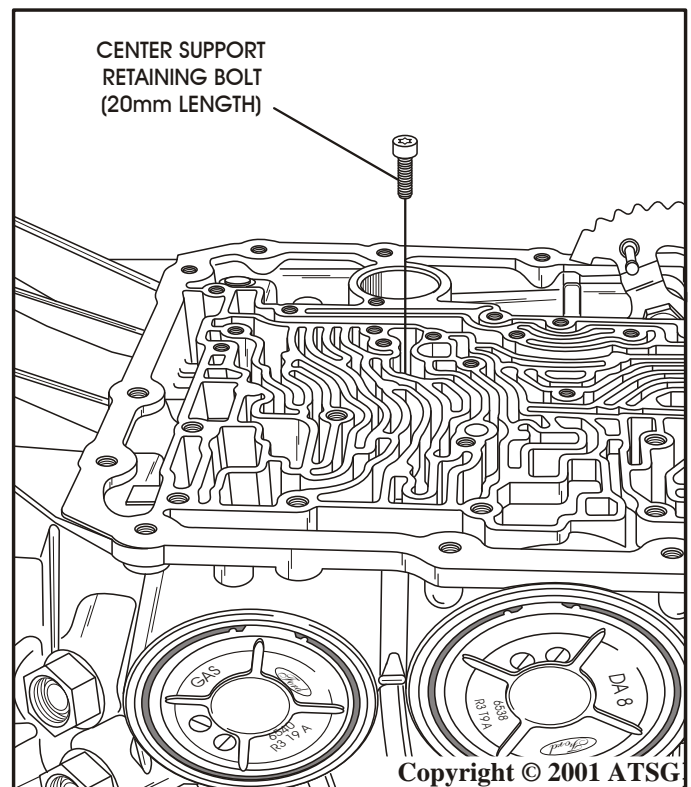

Figure 157

INTERNAL COMPONENTS (Cont'd)

41. Install the center support snap ring with the opening in the snap ring to the opening in the center support, as shown in Figure 158.
42. Now we must once again measure with the dial caliper through the speed sensor hole down to the surface of the direct clutch housing with all of the parts installed in the case, as shown in Figure 160, **and record this as dimension "B"**.
43. Subtract previously recorded dimension "A" from now recorded dimension "B", and this will give you the rear end clearance.

Example: Dimension "B" = .735"
Dimension "A" = .725"
Difference = .010"
44. **Rear end clearance should be .008" to .012"**. Change the selective No. 4 thrust bearing using the chart in Figure 159, as necessary to arrive at the proper end play.

Continued on Page 95

SELECTIVE NO. 4 THRUST BEARING CHART		
THICKNESS	PART NO.	I.D. NOTCHES
.104" - .110"	XW4Z-7D014-CA	None
.111" - .117"	XW4Z-7D014-DA	One
.118" - .125"	XW4Z-7D014-EA	Two
.126" - .132"	XW4Z-7D014-FA	Three

Figure 159

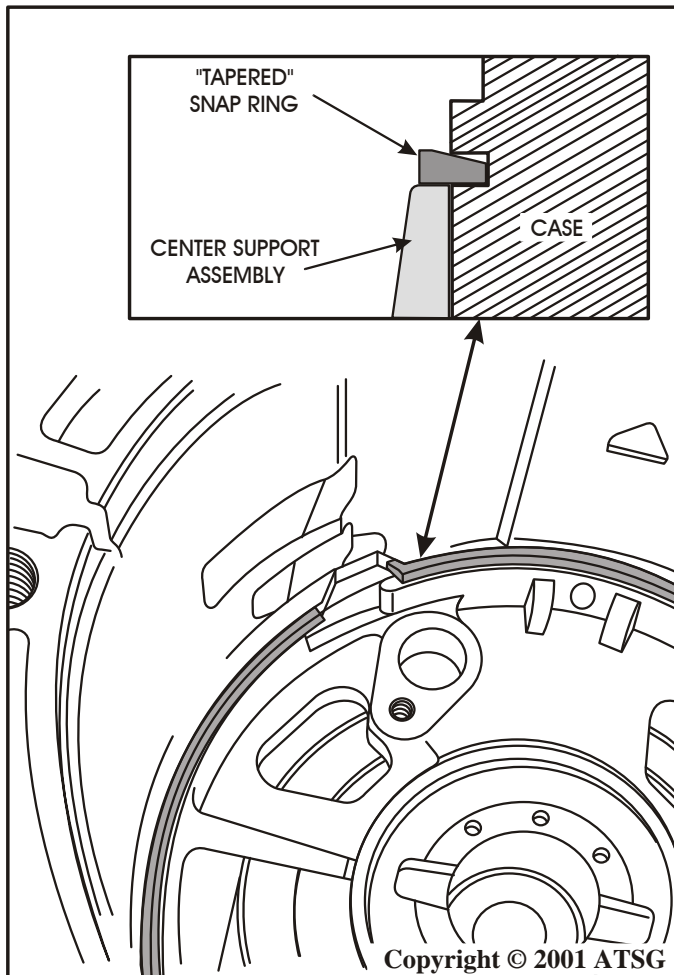

Figure 158

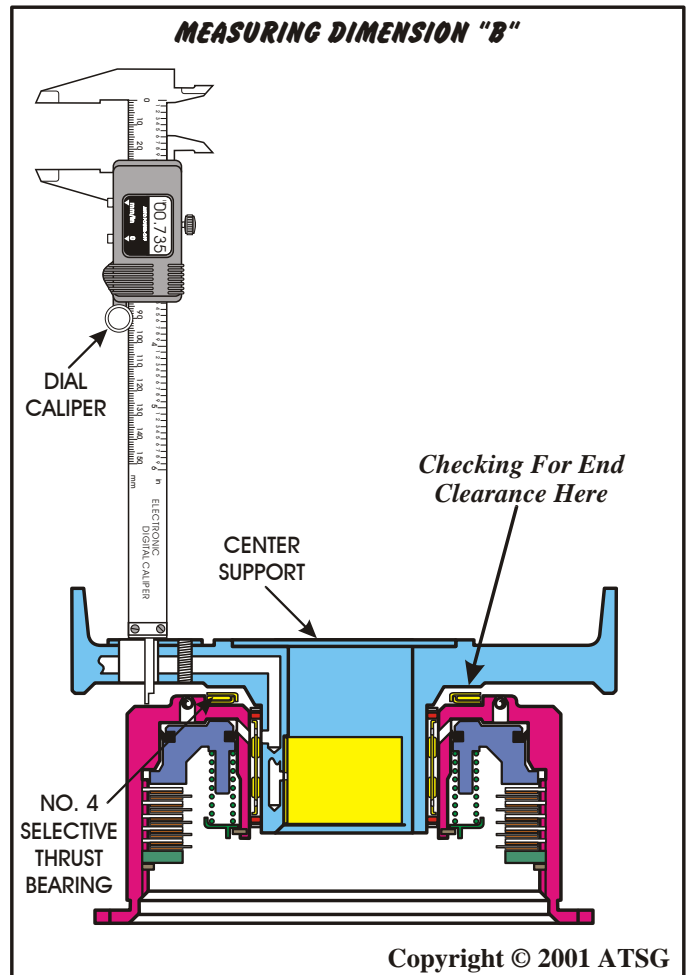

Figure 160

INTERNAL COMPONENTS (Cont'd)

45. Install the center shaft to center support thrust bearing (No. 3) onto the center support, as shown in Figure 161.
46. Install the pre-assembled overdrive carrier and center shaft assembly, as shown in Figure 162, ensuring that it is splined into the forward clutch housing and fully seated.
47. Install the overdrive sun gear into overdrive carrier, as shown in Figure 162, by rotating into position.
48. Install the coast clutch housing adapter plate on overdrive sun gear, as shown in Figure 162, and ensure that it is fully seated.

Continued on Page 97

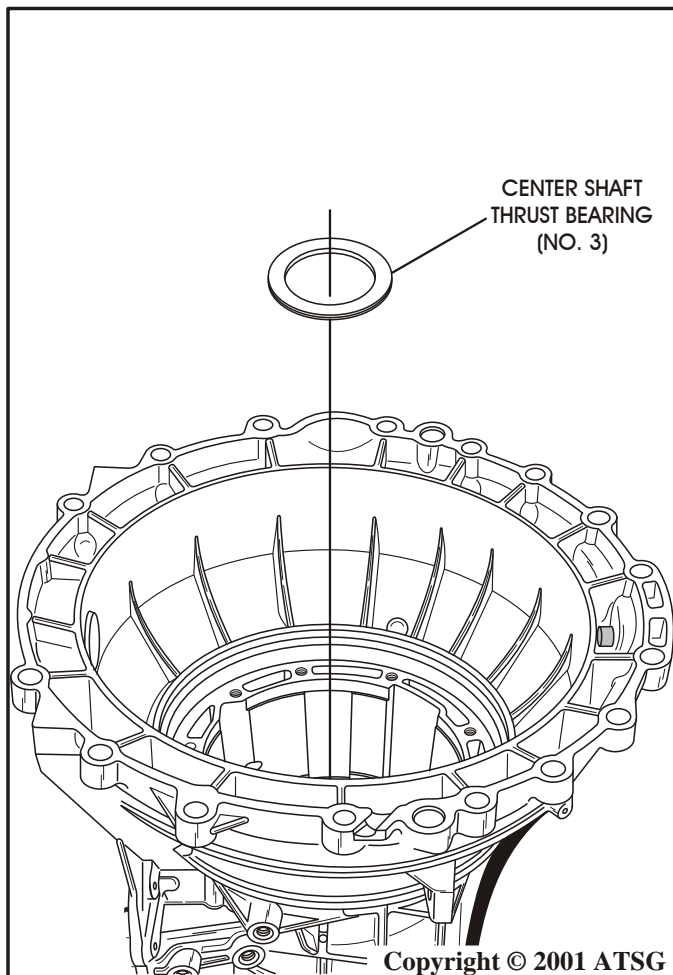

Figure 161

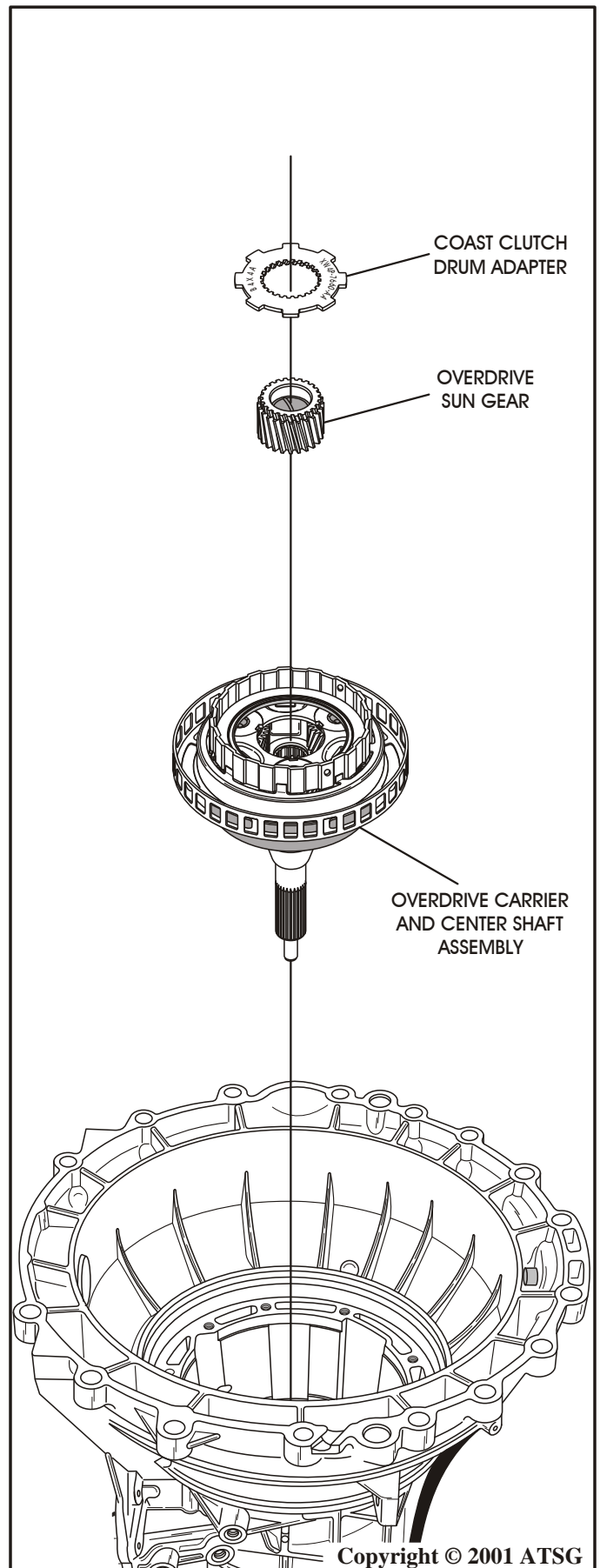

Figure 162

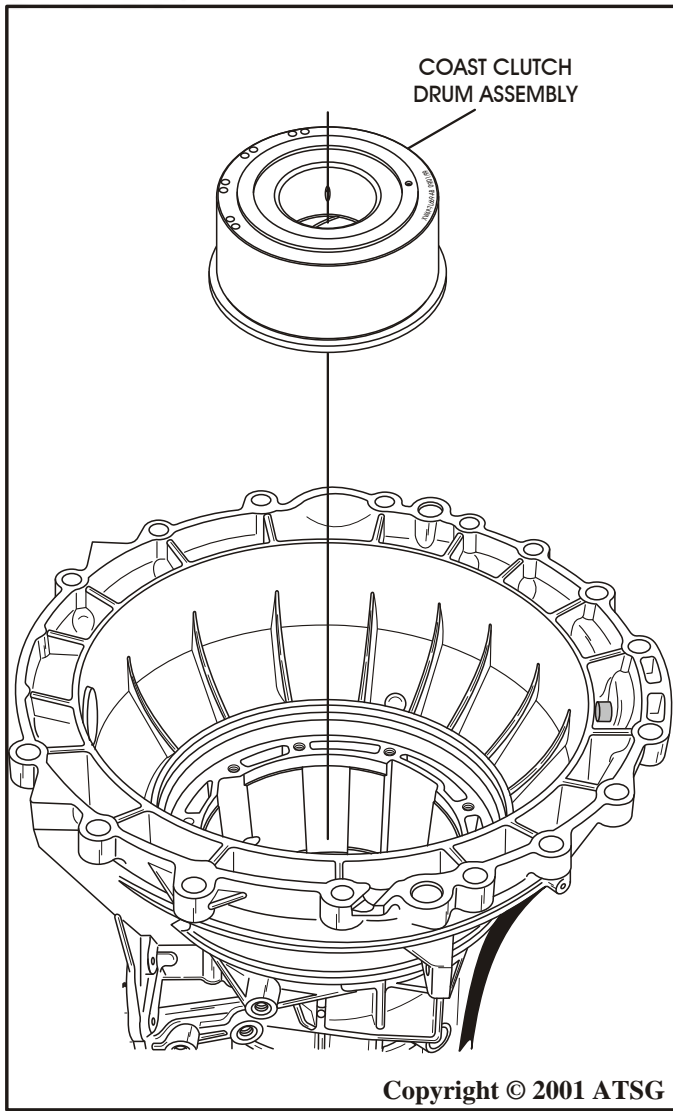

Figure 163

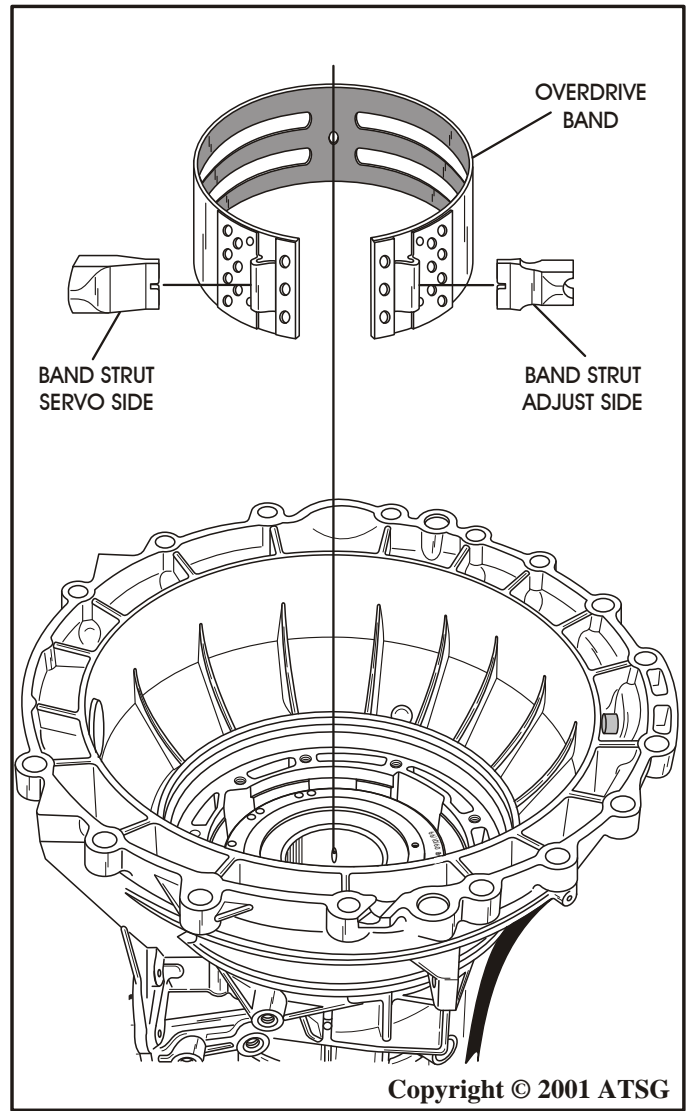

Figure 164

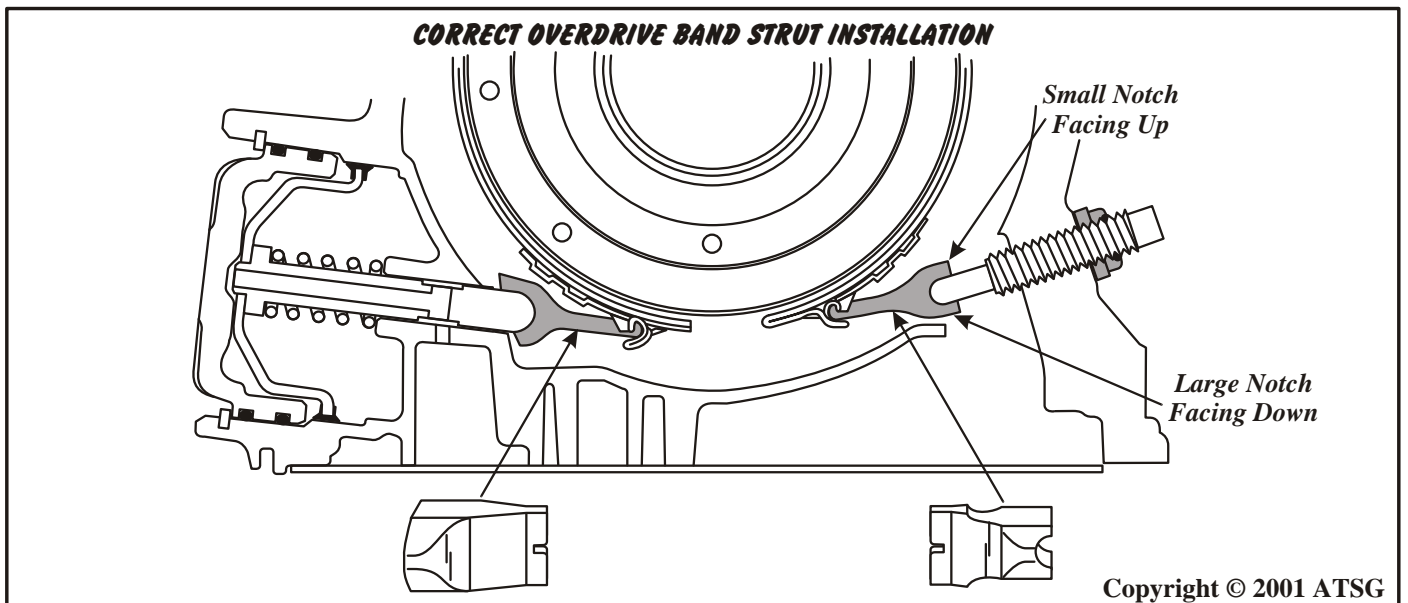
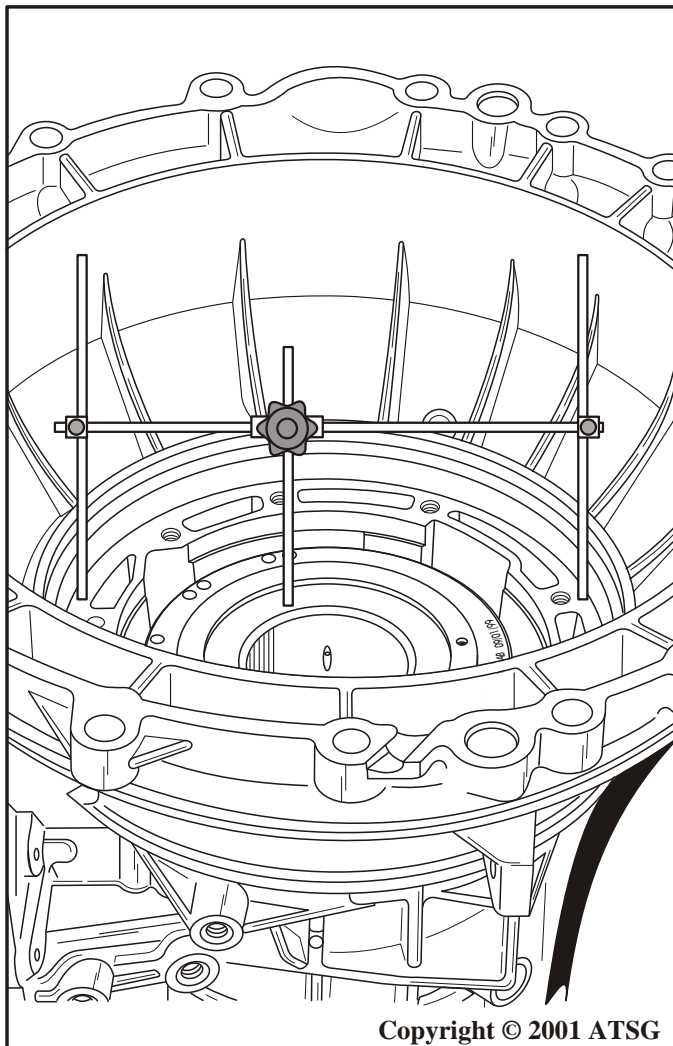

Figure 165

INTERNAL COMPONENTS (Cont'd)

49. Install the pre-assembled coast clutch housing, as shown in Figure 163, by rotating back and forth to engage clutches on hub, until fully seated.
50. Install the overdrive band into transmission and around the coast clutch housing, as shown in Figure 164.
51. Install the overdrive band struts on each side of the band, *exactly* as shown in Figure 164.
Caution: The anchor or adjustment side must have strut installed that is illustrated in Figure 165 and must be installed with the small notch facing the top of transmission. The apply or servo side must also be installed, as shown in Figure 165.
52. Install "H" gauge onto case pump surface and move center rod down to surface on the coast clutch where selective thrust washer rides, as shown in Figure 166.



Copyright © 2001 ATSG

Figure 166

INTERNAL COMPONENTS (Cont'd)

53. Install pump gasket onto the pre-assembled oil pump, as shown in Figure 167.
54. Place the "H" gauge with the previously set center rod onto the oil pump in the opposite direction, with the center rod placed over the selective washer, as shown in Figure 167.
55. Measure with a feeler gage between the center rod and selective thrust washer, as shown in Figure 167.
56. Front end clearance should be .012" - .018". Change the selective oil pump thrust washer from the chart below, as necessary, to achieve proper front end clearance.

Continued on Page 98

SELECTIVE OIL PUMP THRUST WASHER CHART		
THICKNESS	PART NO.	I.D. COLOR/NO.
.066" - .069"	XW4Z-7D014-XA	Brown/"8"
.073" - .075"	XW4Z-7D014-NA	Red/"4"
.080" - .082"	XW4Z-7D014-RA	Black/"6"
.087" - .089"	XW4Z-7D014-YA	Orange/"9"
.094" - .096"	XW4Z-7D014-ZA	Purple/"10"

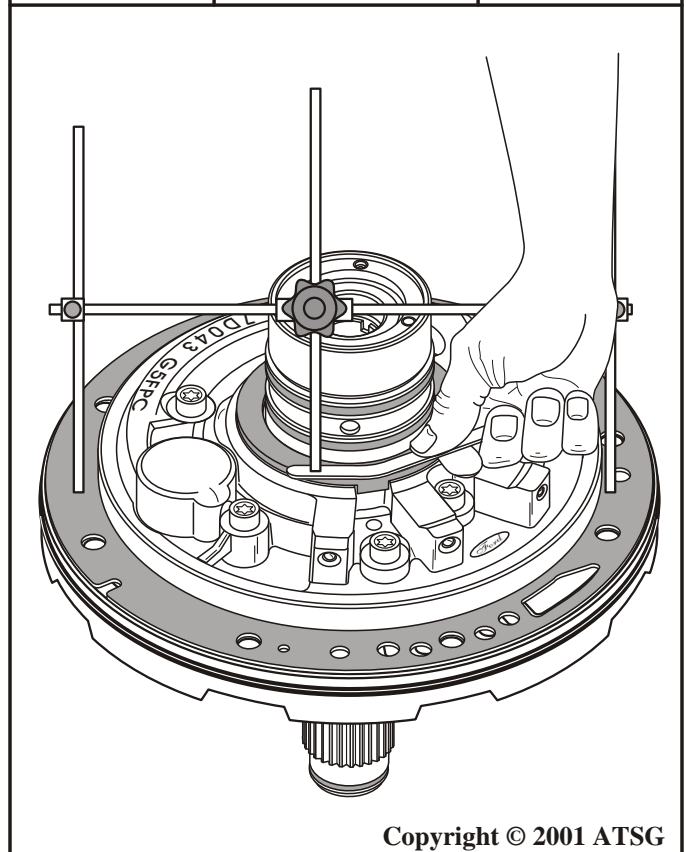

Copyright © 2001 ATSG

Figure 167

INTERNAL COMPONENTS (Cont'd)

57. Install the oil pump to case gasket into case, as shown in Figure 168, and align holes.
58. Lubricate the case bore where the "O" ring rides with a small amount of Trans-Jel®.
59. Install the pre-assembled oil pump assembly into the case, as shown in Figure 168, using care not to damage the pump "O" ring.
60. Install the eight oil pump assembly retaining bolts, and torque to 25Nm (18 ft.lb.), as shown in Figure 169.
61. Rotate the transmission so that the valve body surface is facing up, as shown in Figure 170.
62. Torque the center support retaining bolt down to 11 Nm (100 in.lb.), (See Figure 170).

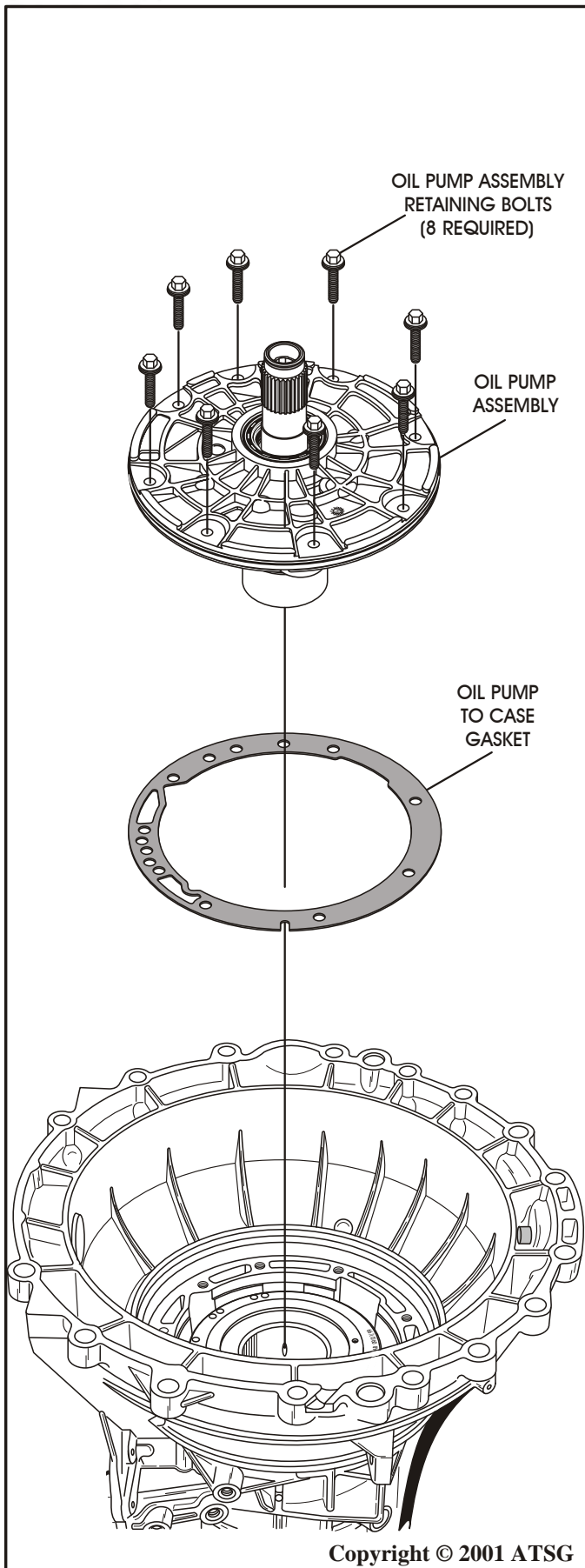

Figure 168

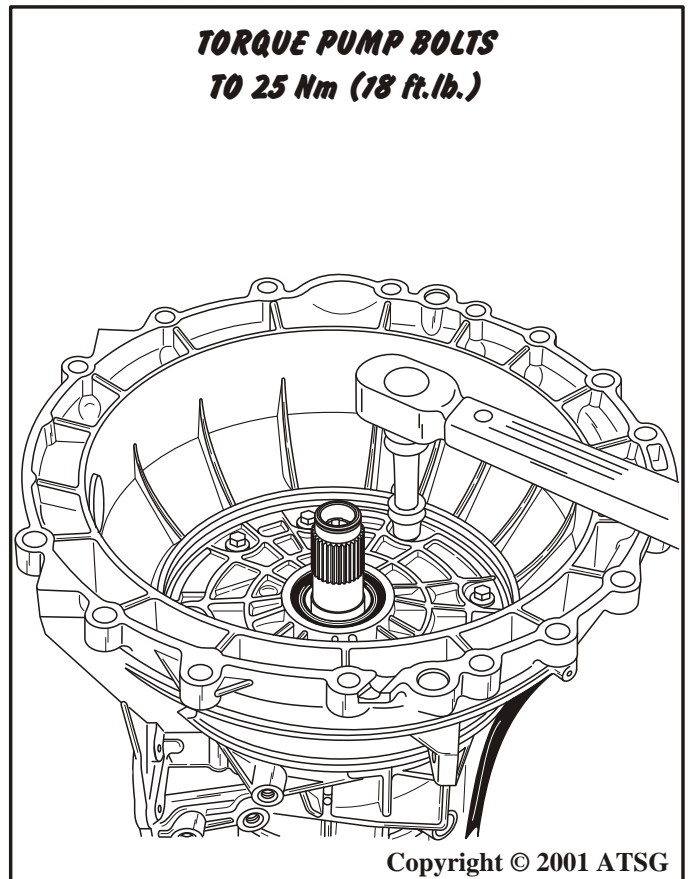

Figure 169

INTERNAL COMPONENTS (Cont'd)

63. Install new locking nuts on both band adjusting screws, using care not to let the adjusting screw come out, so that the band anchors will not fall out and into transmission (See Figure 171).
64. Adjust the overdrive band by turning adjusting screw in while holding the lock nut. Torque the adjusting screw to 14 Nm (10 ft.lb.) and then back out *exactly* two (2) full turns. Refer to Figure 171.
65. Adjust intermediate band by turning adjusting screw in while holding the lock nut. Torque the adjusting screw to 14 Nm (10 ft.lb.) and then back out *exactly* two (2) full turns. Refer to Figure 171.
66. Install intermediate clutch seal and retaining spring into the transmission case cavity, shown in Figure 172.

Caution: This seal should be installed using a drift punch and installed by hand to ensure it is fully seated against housing.

Continued on Page 100

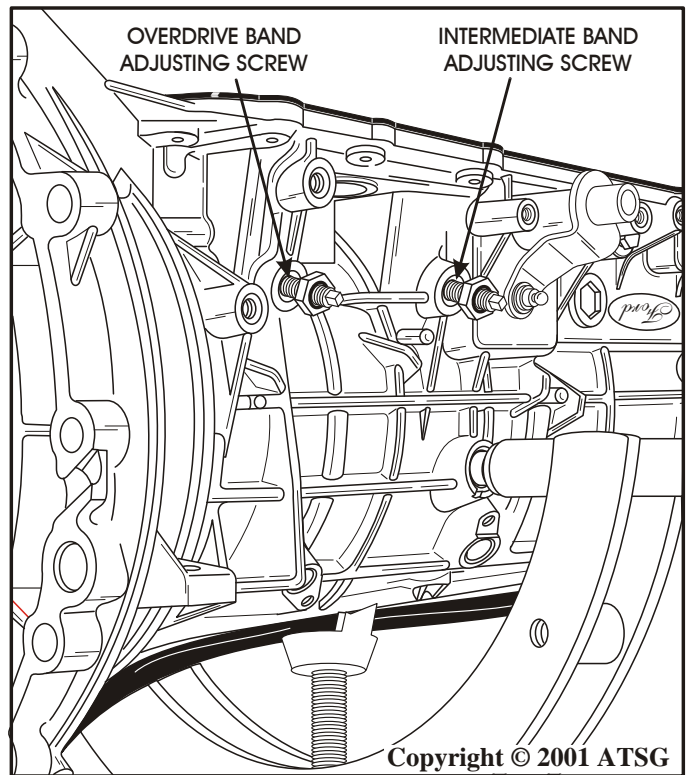

Figure 171

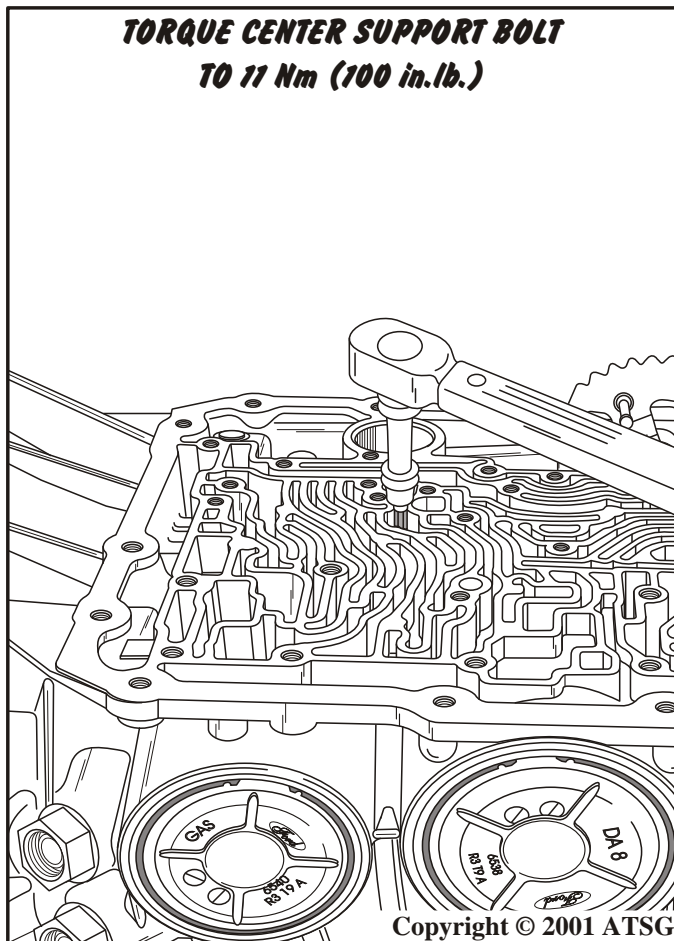

Figure 170

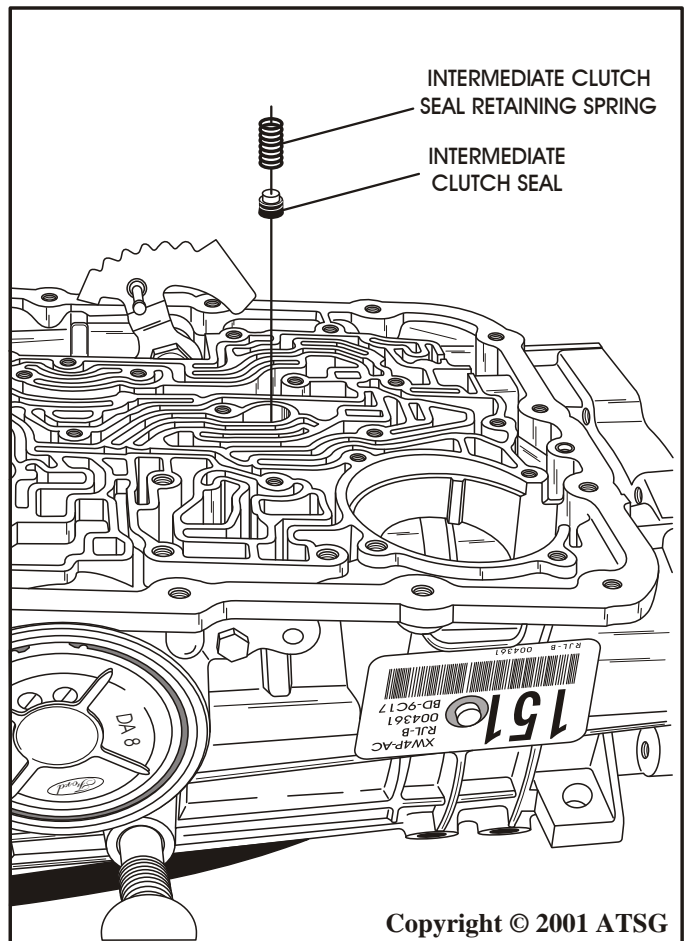

Figure 172

INTERNAL COMPONENTS (Cont'd)

67. Install the pre-assembled valve body assembly onto the case, as shown in Figure 173.

Caution: Ensure that manual valve is engaged on inside detent lever properly.

68. Install the valve body retaining bolts into the exact locations, as shown in Figure 173, finger tight only, and paying attention to the length of the bolts to ensure proper location.

69. Install the detent spring and retaining bolt, as shown in Figure 173, finger tight only.

70. Install the pre-checked solenoid body assembly onto transmission, as shown in Figure 174, and finger tighten only.

Note: Refer to Page 5 for solenoid body specifications as necessary.

Continued on Page 102

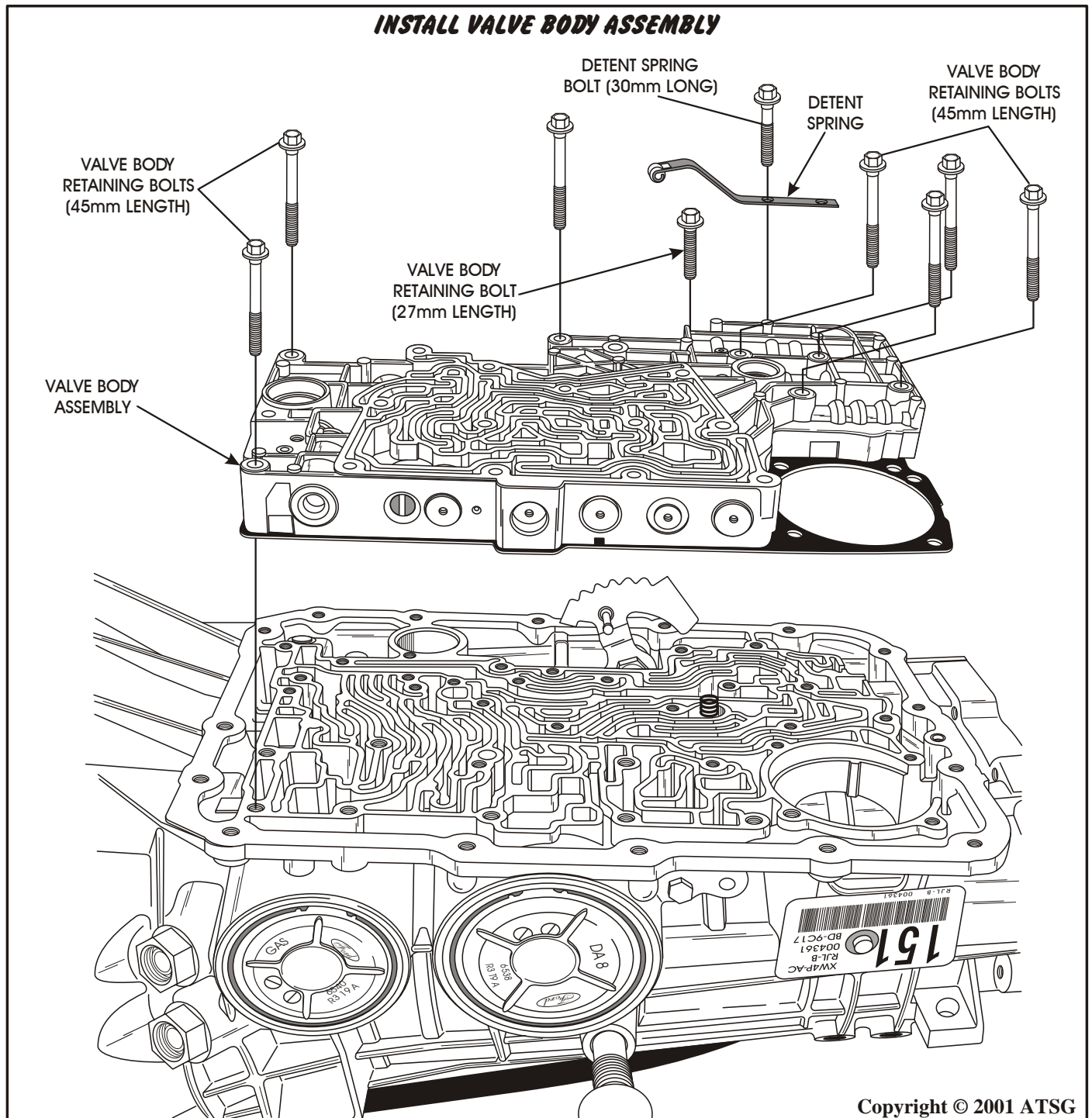

Figure 173

INTERNAL COMPONENTS (Cont'd)

71. Install the valve body cover plate gasket and valve body cover plate as shown in Figure 175.
72. Install the ten valve body cover plate bolts in the *exact* locations shown in Figure 175, and finger tighten only.
73. Install the reverse switch onto the cover plate as shown in Figure 176, finger tighten only and plug the harness connector into the solenoid body (See Figure 176).
74. Install pre-assembled reverse servo assembly onto spacer plate, as shown in Figure 176, and finger tighten only.
75. Torque the valve body and cover bolts down to 10 Nm (89 in.lb.), beginning in the center and working outward in a circle.
76. Torque solenoid body bolts to 8 Nm (71 in.lb.).
77. Torque reverse servo bolts to 10 Nm (10 ft.lb.).

Continued on Page 104

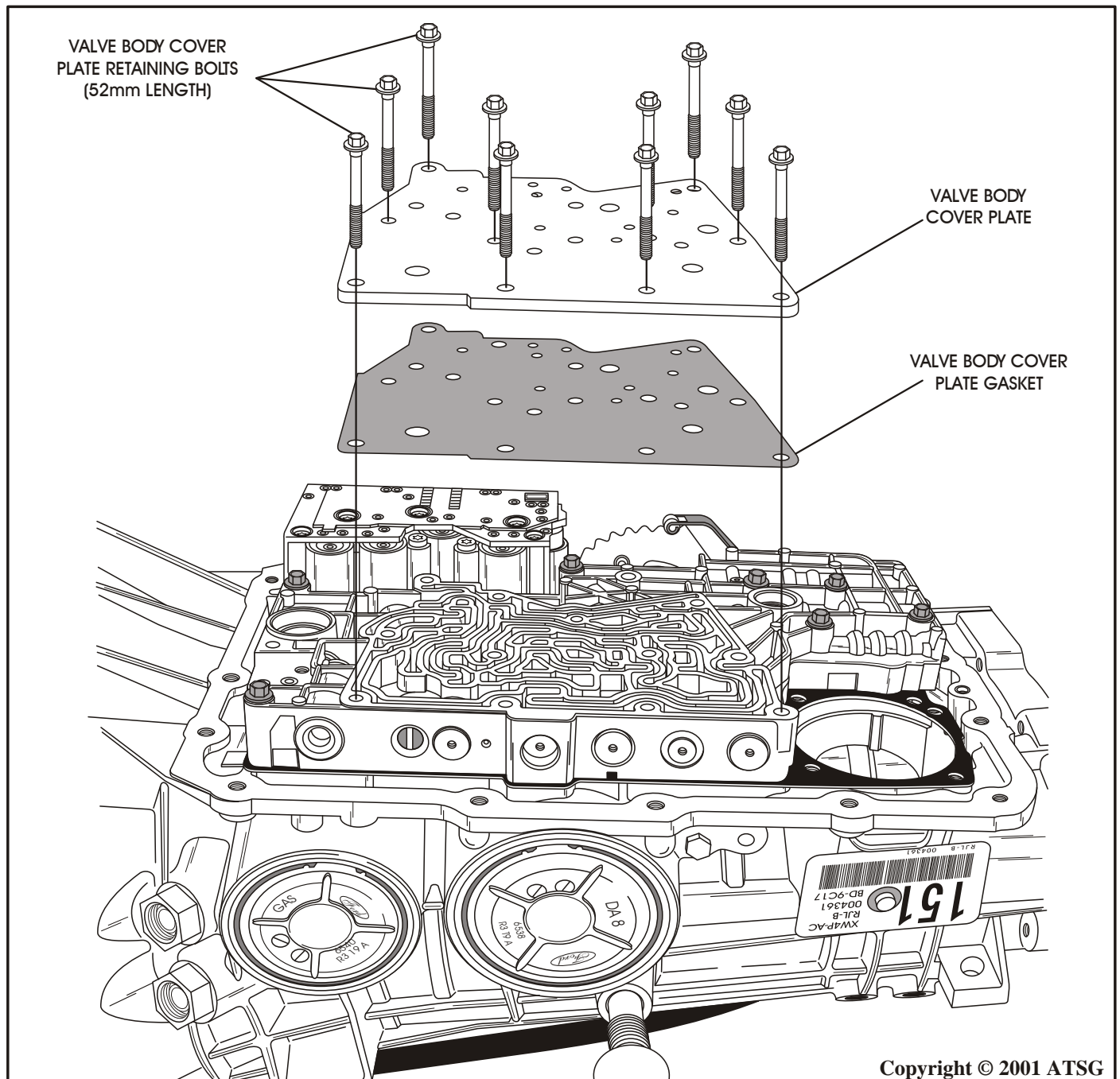
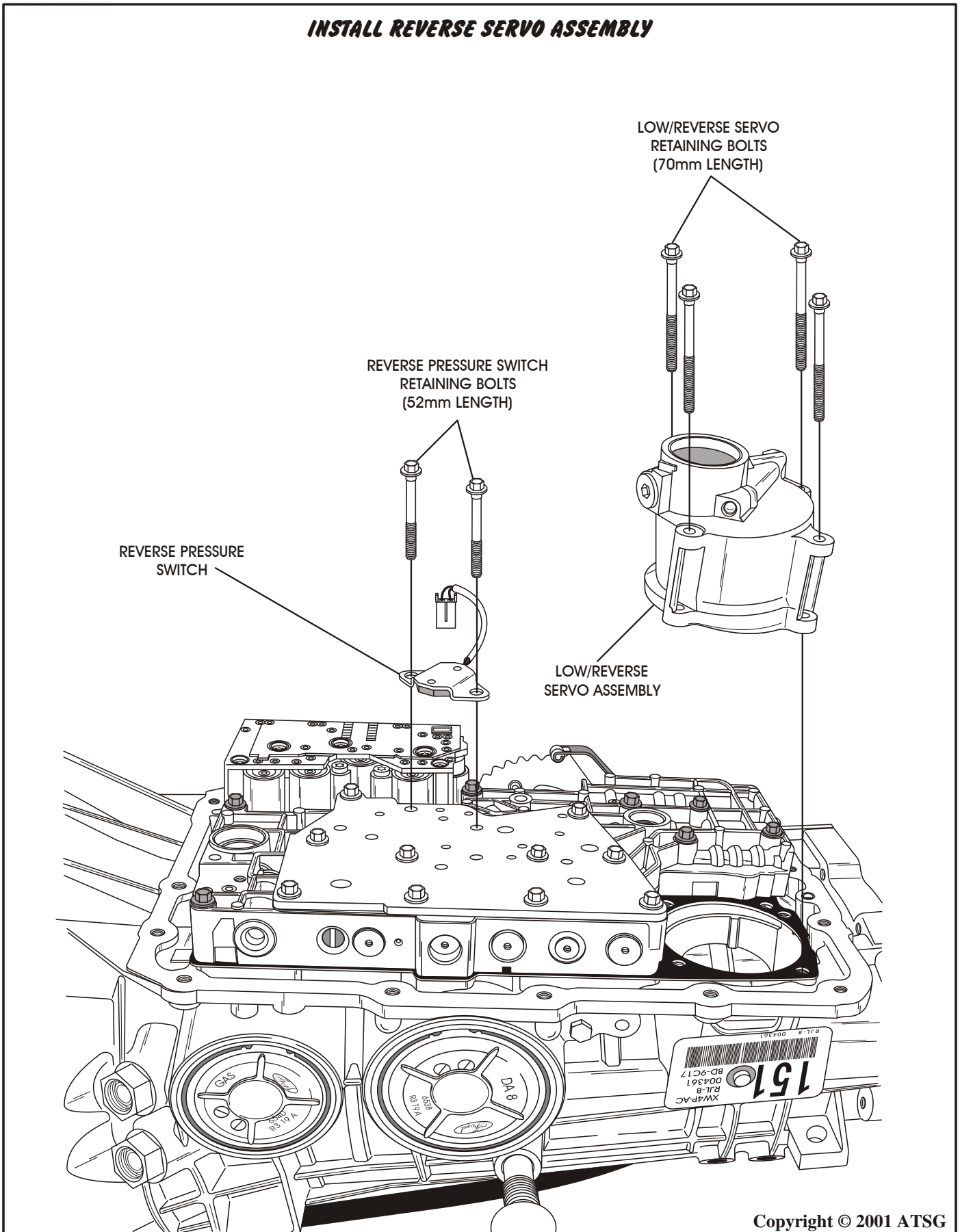

Figure 175

INSTALL REVERSE SERVO ASSEMBLY



Copyright © 2001 ATSG

Figure 176

INTERNAL COMPONENTS (Cont'd)

78. Install new filter seals on new filter and install filter assembly, as shown in Figure 177.
79. Torque both filter bolts to 10 Nm (10 ft.lb.).
80. Install new pan gasket onto transmission case, as shown in Figure 178.

Note: This pan gasket is re-usable as long as none of the beads are broken.

81. Install the bottom pan assembly and the sixteen bottom pan bolts, as shown in Figure 178, and torque the bolts to 11 Nm (8 ft.lb.) using the "criss-cross" sequence.

Continued on Page 106

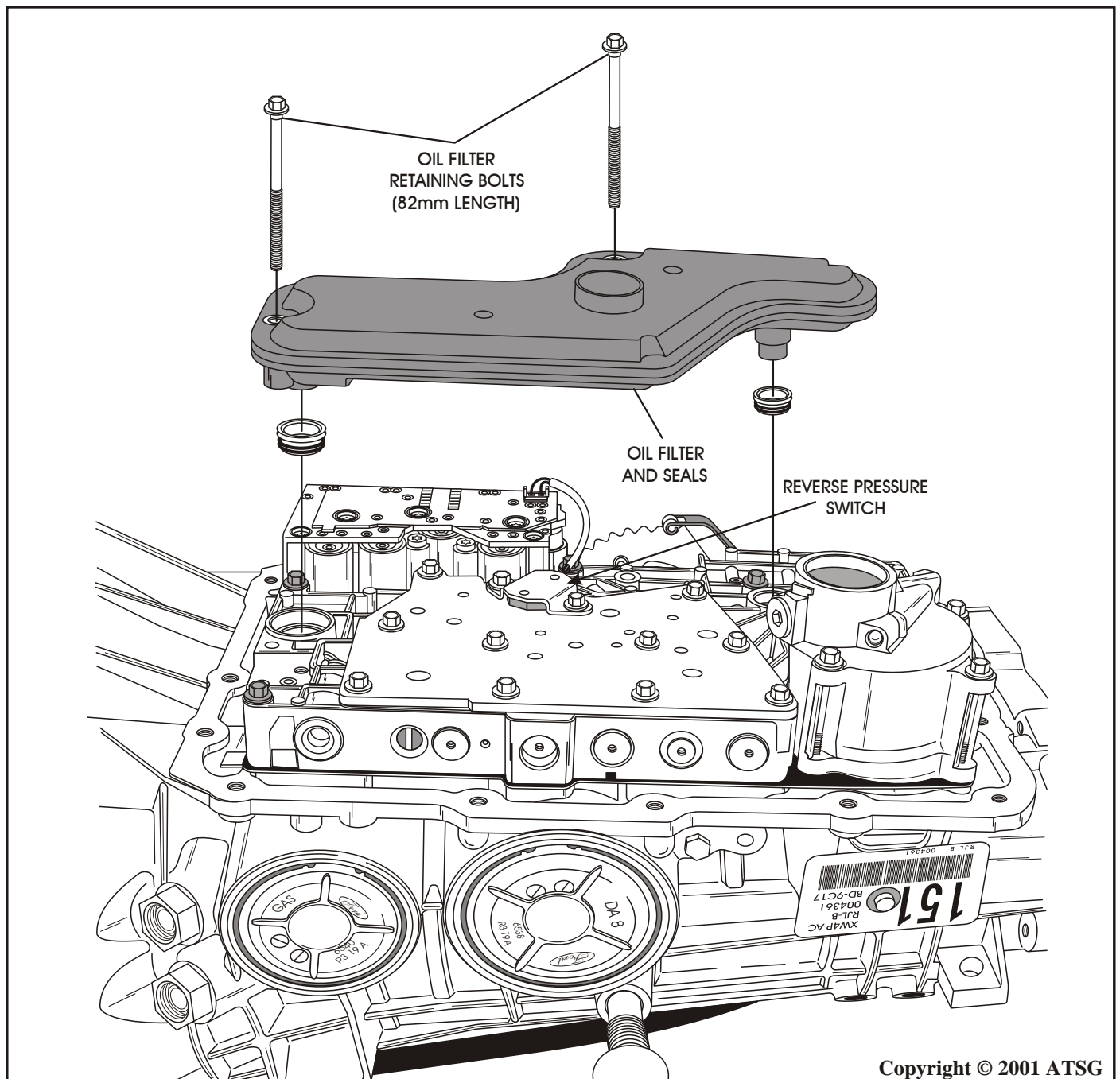
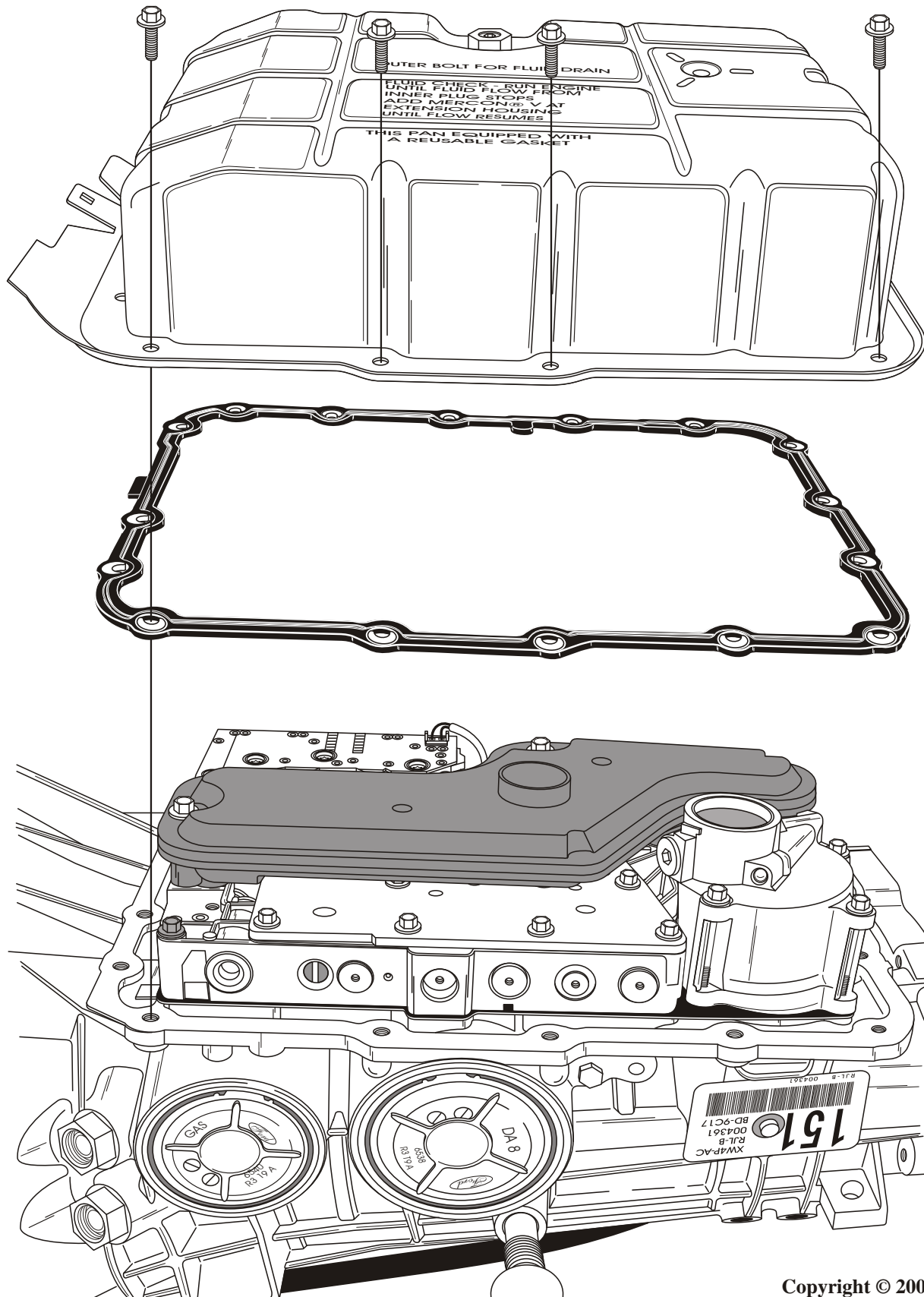

Figure 177

Copyright © 2001 ATSG

INSTALL BOTTOM PAN AND GASKET



Copyright © 2001 ATSG

Figure 178

INTERNAL COMPONENTS (Cont'd)

82. Rotate transmission so that rear is facing up, as shown in Figure 179.
83. Install new extension housing gasket onto case, as shown in Figure 179.
84. Install pre-assembled extension housing onto case, as shown in Figure 179, ensuring that the parking rod goes between the parking pawl and the case.
85. Install the seven (7) extension housing bolts, as shown in Figure 179, and torque to 39 Nm (29 ft.lb.).

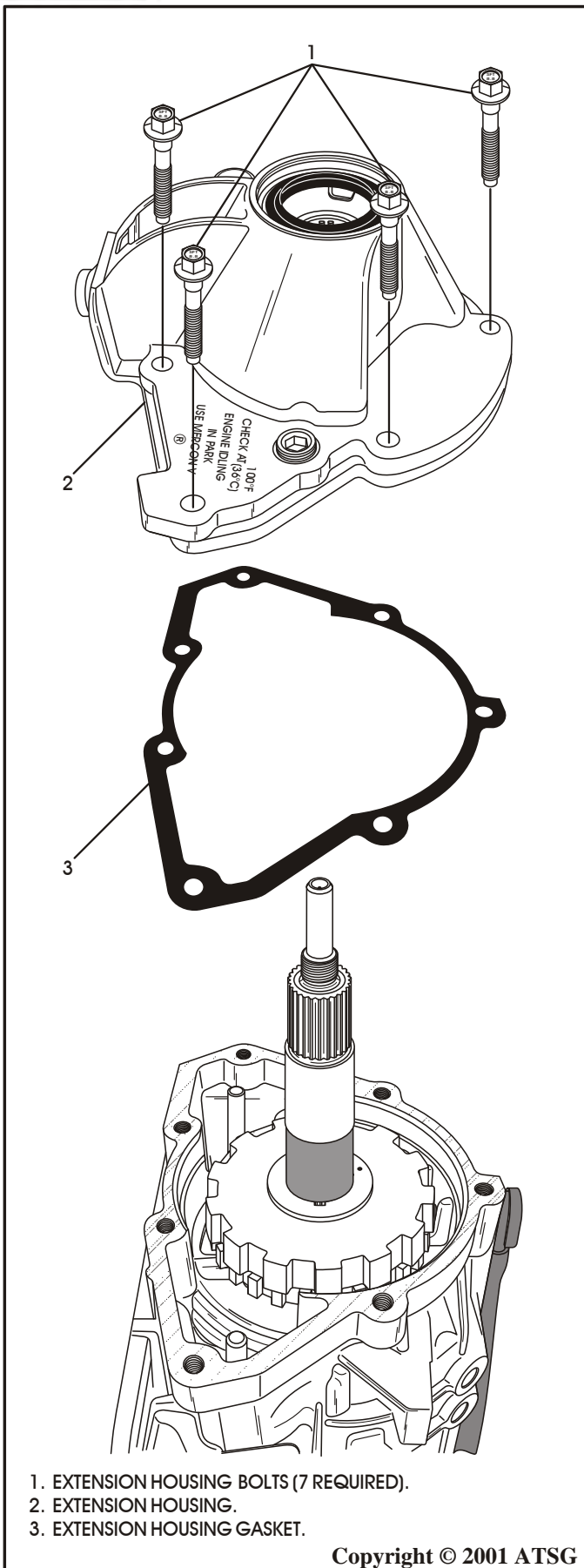

Figure 179

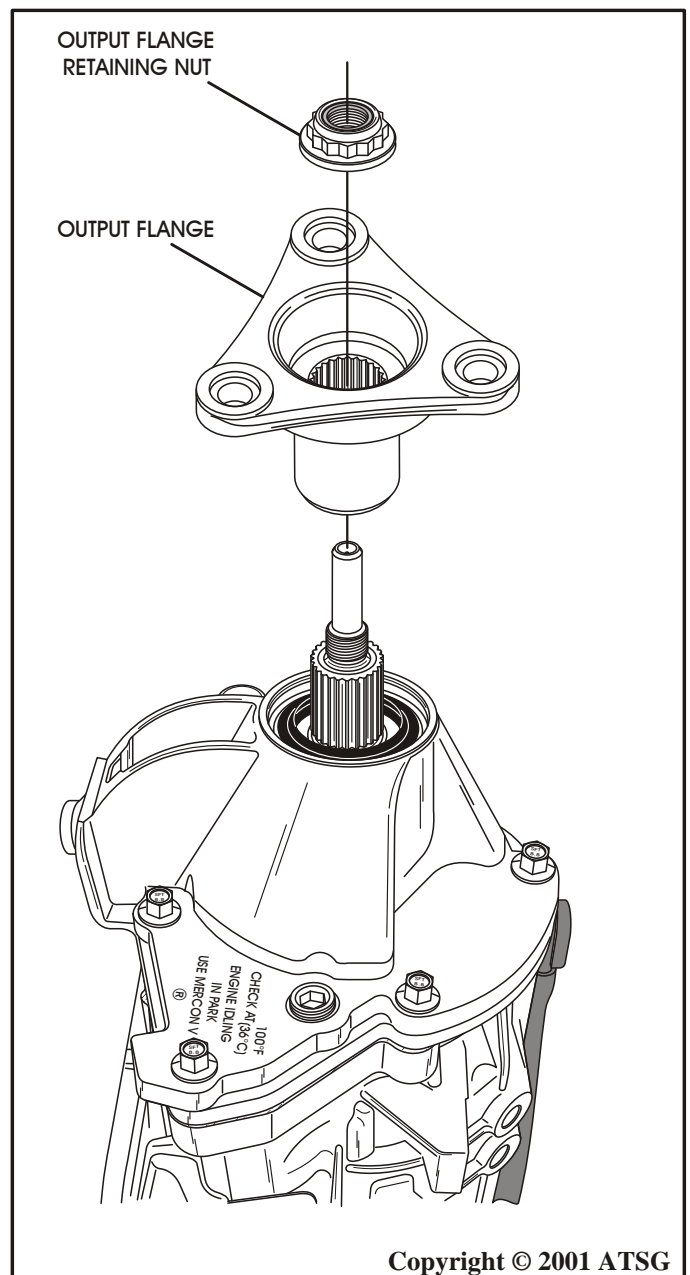

Figure 180

INTERNAL COMPONENTS (Cont'd)

86. Install the output flange onto the output shaft, as shown in Figure 180.
- Caution:** Ford recommends a special tool to install the output flange to avoid damaging any internal parts (See Figure 181).
87. Install a *new* output flange retaining nut and torque to 131 Nm (97 ft.lb.), as shown in Figure 182.
88. Rotate transmission so that pan is facing down as shown in Figure 183, and remove complete assembly from the bench fixture.

Continued on Page 108

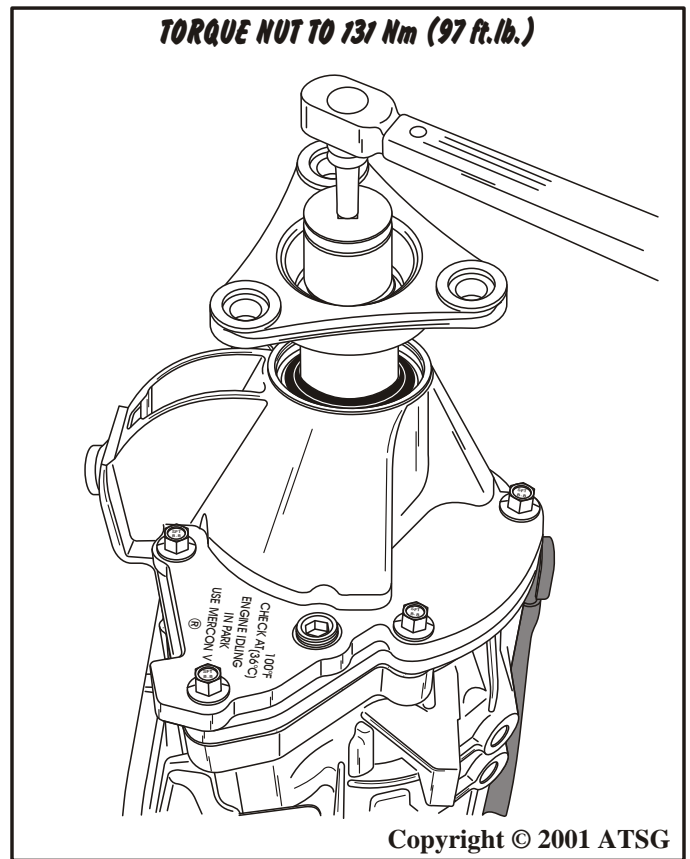

Figure 182

Copyright © 2001 ATSG

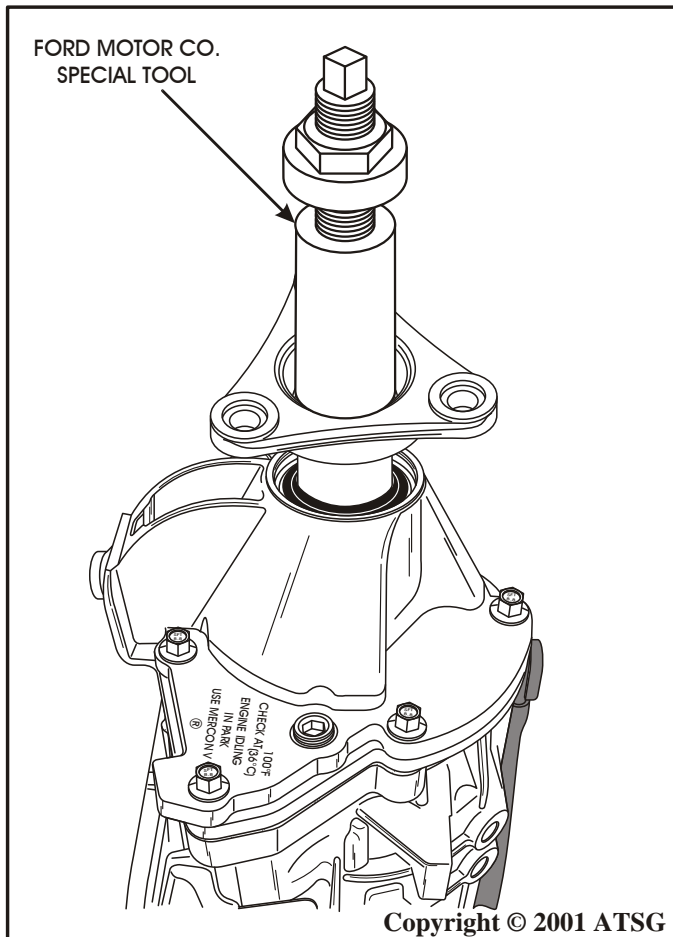

Figure 181

Copyright © 2001 ATSG

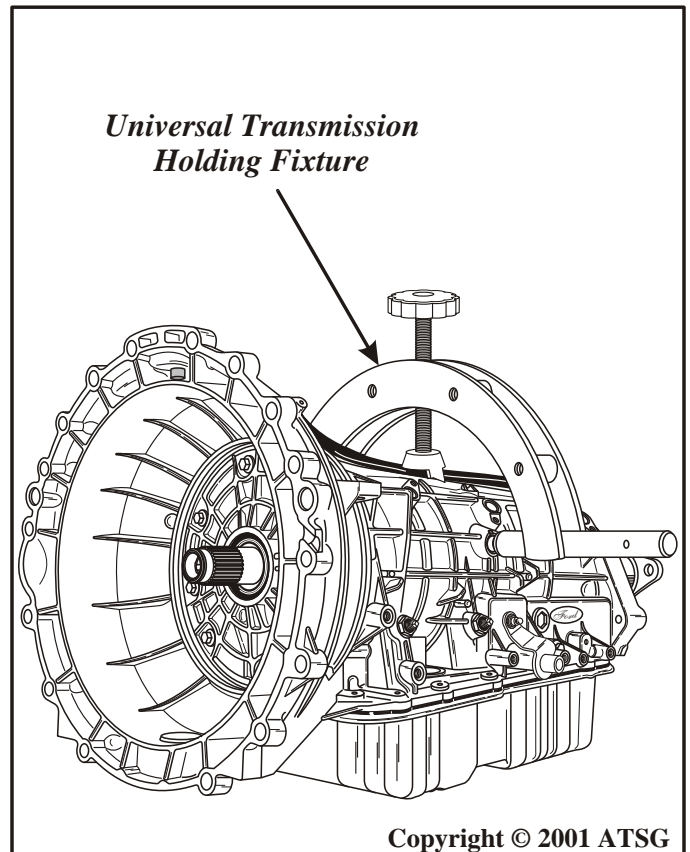

Figure 183

Copyright © 2001 ATSG

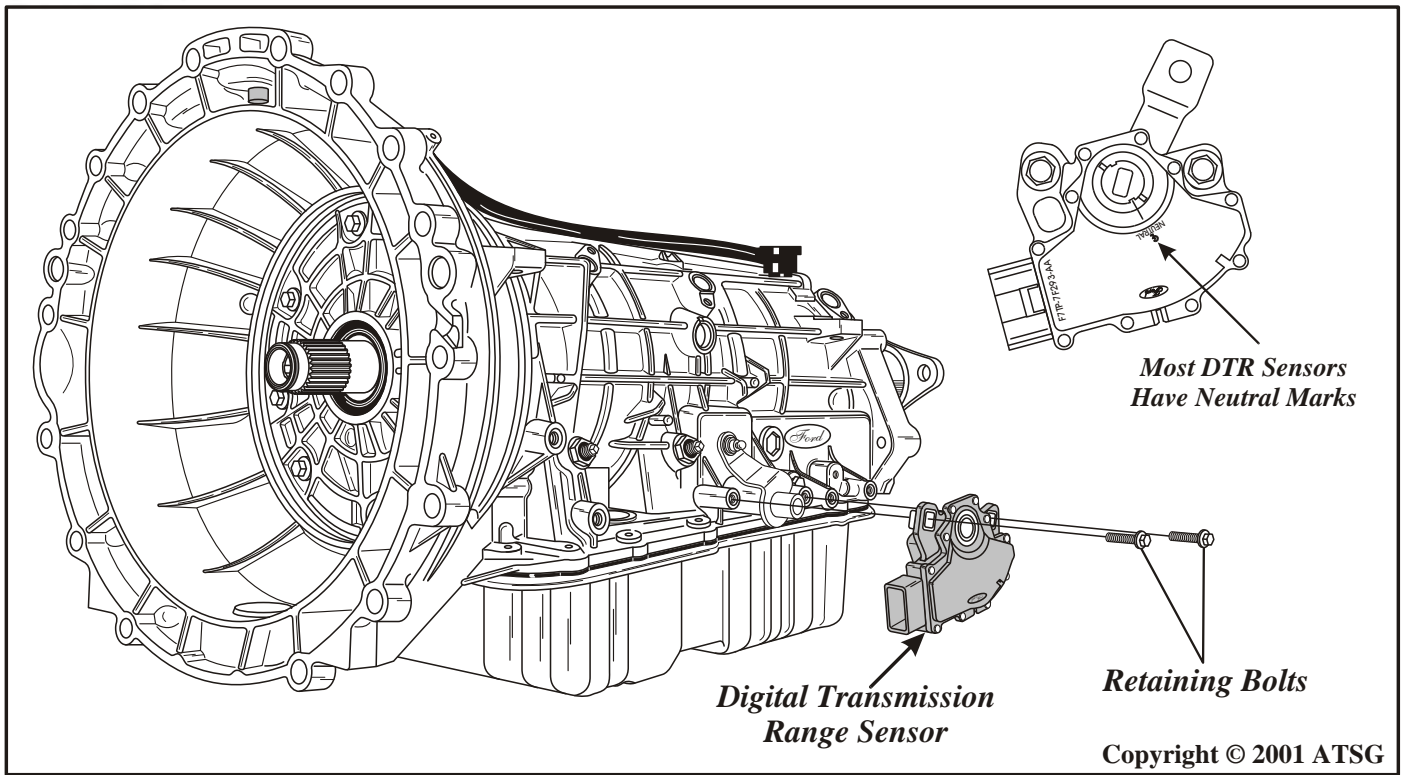

Figure 184

EXTERNAL COMPONENTS

1. Place the manual lever in the neutral position and install the Digital Transmission Range sensor, as shown in Figure 184.
2. Install the two DTR retaining bolts finger tight at this time (See Figure 184).
3. Install the adjustment gage and tighten the two DTR bolts by alternating from side to side, and torque to 10 Nm (89 in.lb.).

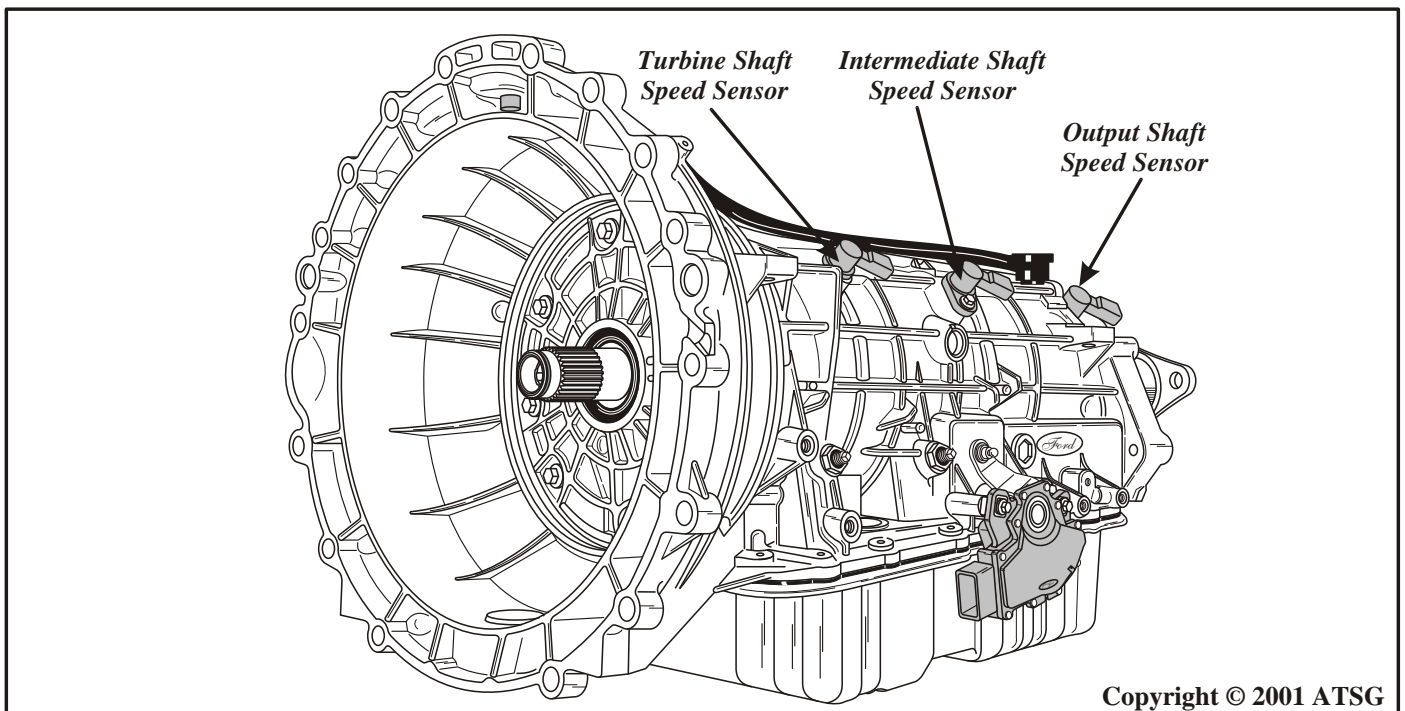

Figure 185

EXTERNAL COMPONENTS

4. Install a new "O" ring on turbine speed sensor and install into case in the location, as shown in Figure 185.
Note: Use Figure 186 to identify the three speed sensor assemblies, and use the chart on Page 17 for proper Ohms readings.
5. Install a new "O" ring on the intermediate shaft speed sensor and install into case in the location shown in Figure 185.
Note: Use Figure 186 to identify the three speed sensor assemblies, and use the chart on Page 17 for proper Ohms readings.
6. Install a new "O" ring on output shaft speed sensor and install in case in the location shown in Figure 185.
Note: Use Figure 186 to identify the three speed sensor assemblies, and use the chart on Page 17 for proper Ohms readings.
7. Torque all three speed sensor retaining bolts to 10 Nm (89 in.lb.).
8. Check and ensure that both oil pressure plugs are tight, as shown in Figures 187 and 188.

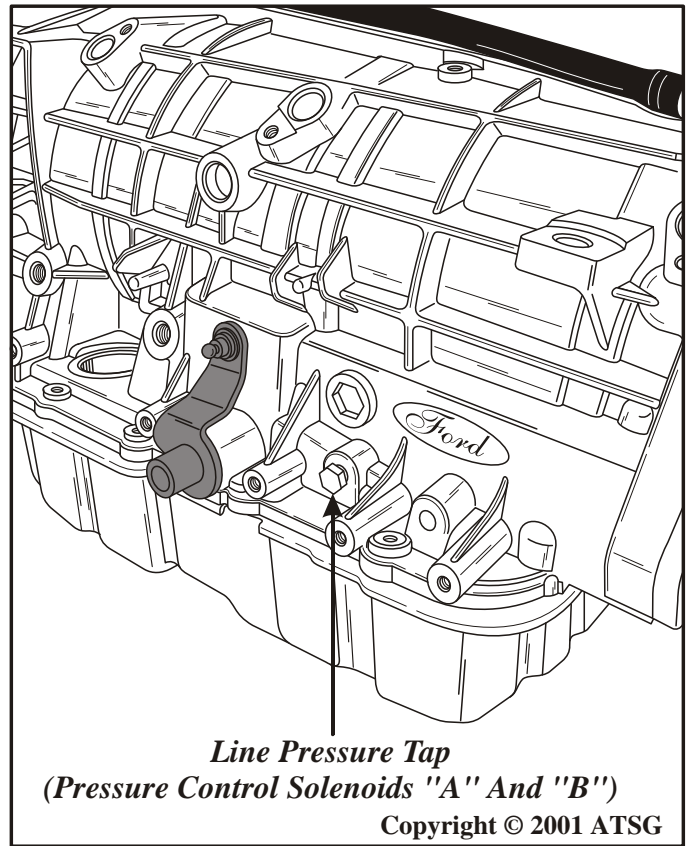

Figure 187

Continued on Page 110

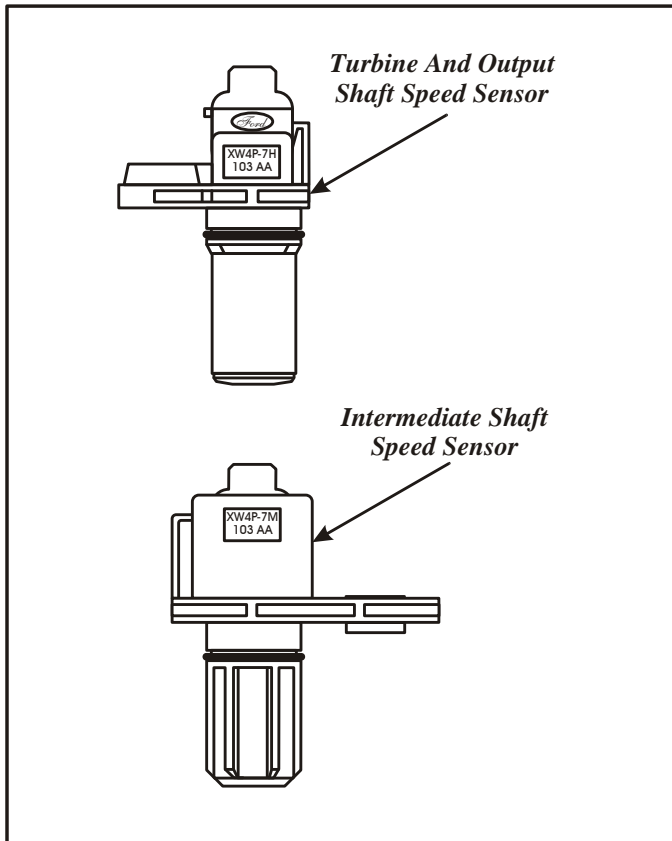

Figure 186

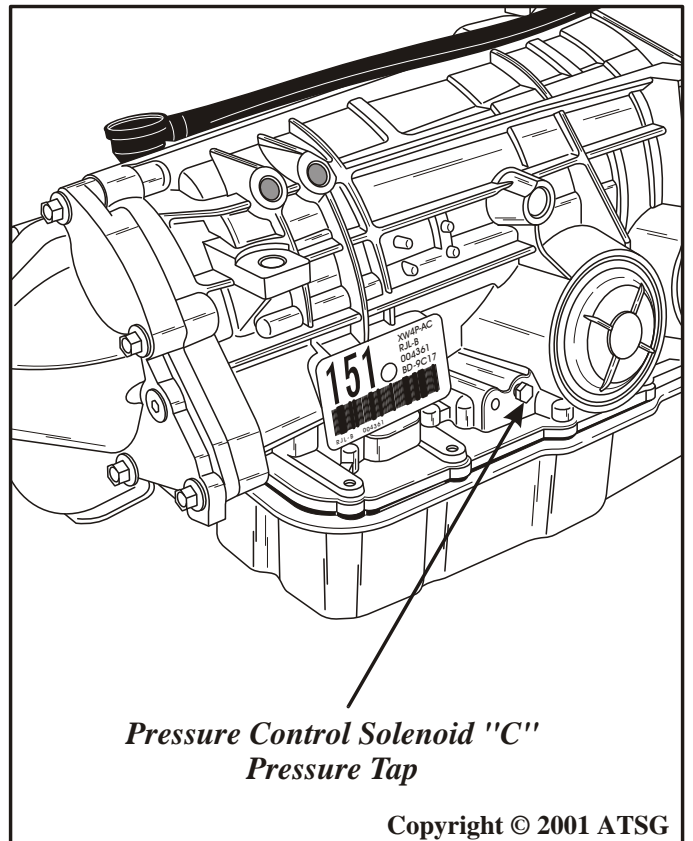

Figure 188

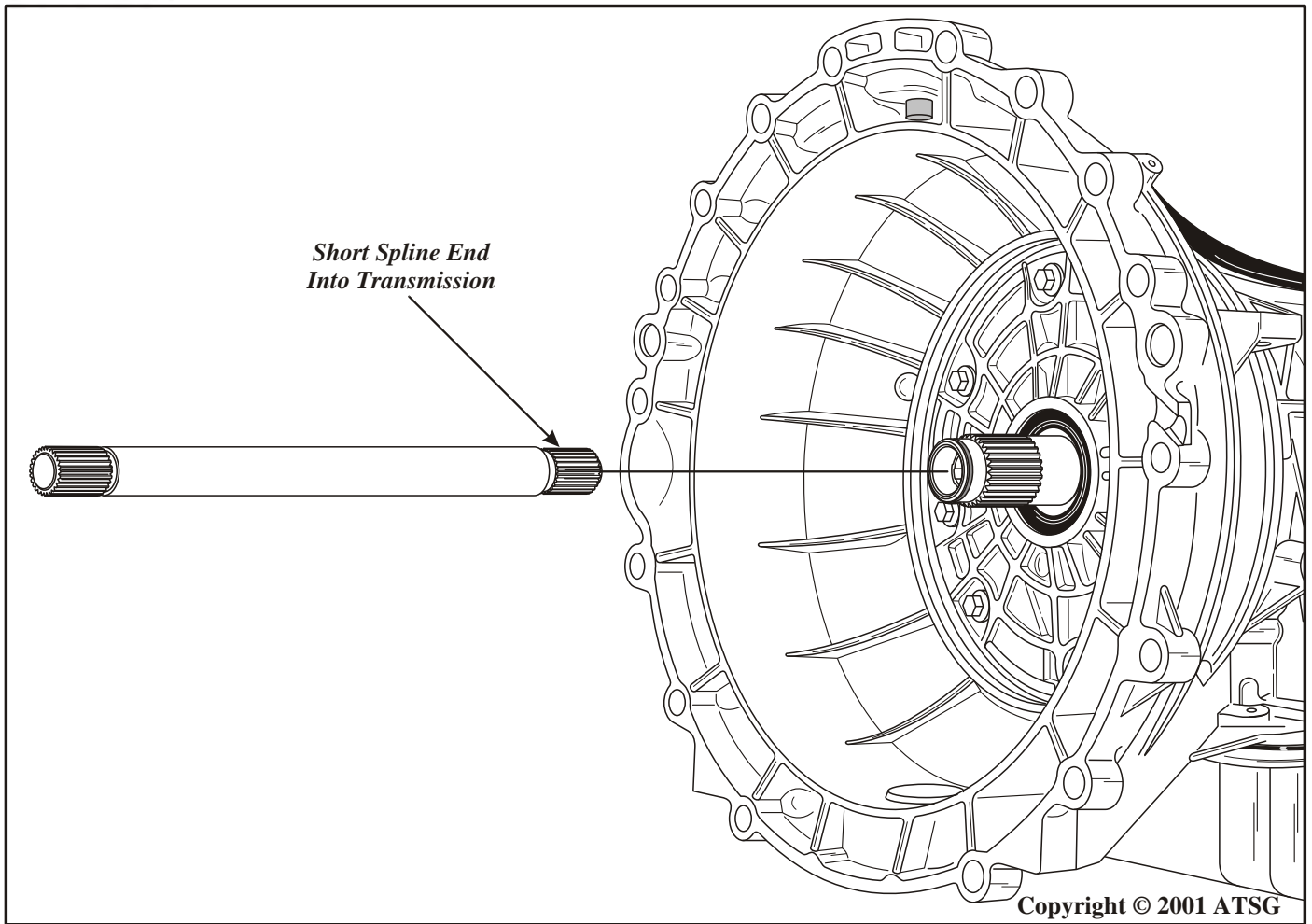

Figure 189

EXTERNAL COMPONENTS

9. Install the input shaft into the transmission, as shown in Figure 189.

Caution: The splines on input shaft are not the same length on both ends. The end with the shorter splines goes into transmission, as shown in Figure 189.

SPECIAL NOTE:
THIS UNIT REQUIRES MERCON V®.

**CONGRATULATIONS!
YOU ARE FINISHED.**

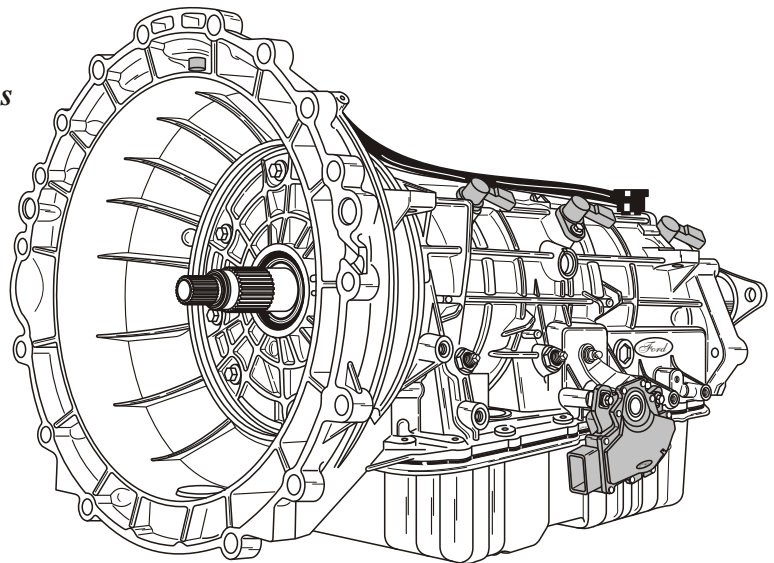

BOLT CHART

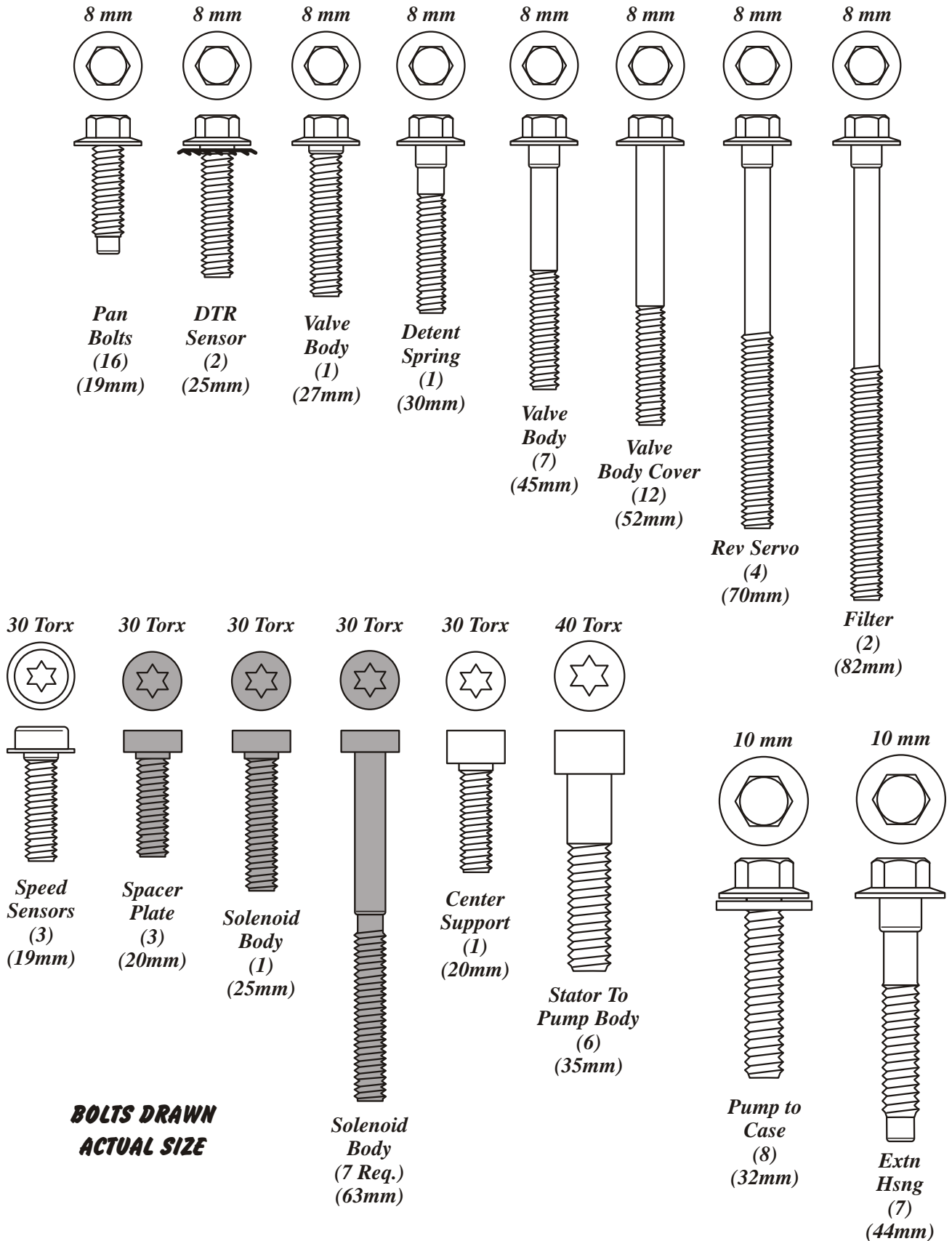

**BOLTS DRAWN
ACTUAL SIZE**

Figure 190

FORD 5R55N

CHECKING FLUID LEVEL

Checking the fluid level on any vehicle equipped with Ford Motor Company's new 5R55N transmission may become confusing to some technicians. There is a plug in the extension housing, shown in Figure 193, that would lead one to believe that this is where you check the fluid level, since some of the other manufacturers are currently checking fluid level in this manner, and it refers to the correct temperature to check the fluid right on the extension housing.

However, this is a **"Fill" plug only** on the new 5R55N transmission from Ford Motor Company, which is currently found in the 2000 Lincoln LS and some Jaguars. To **"Check"** for the correct fluid level, you must remove the **check plug**, which is located in the center of the bottom pan drain plug, and is removed with an allen wrench, as shown in Figure 193, while holding the drain plug with the proper size wrench so as not to loosen the drain plug.

We have provided you with a cut-away drawing of the bottom oil pan and the drain plug so that you will understand how this system works. Notice that the drain plug actually has a "stem" made on it that extends some distance up into the bottom pan, which is our way to establish the proper fluid level in the transmission. By removing the "Check" plug from the "Drain" plug, the fluid should just trickle over the stem and out through the center of the drain plug, as shown in Figure 193. The **"Fill"** plug in the extension housing is your only way to replace and/or fill with fluid, in the 5R55N transmission.

We have also identified the cooler line fittings and lines, as shown in Figure 192.

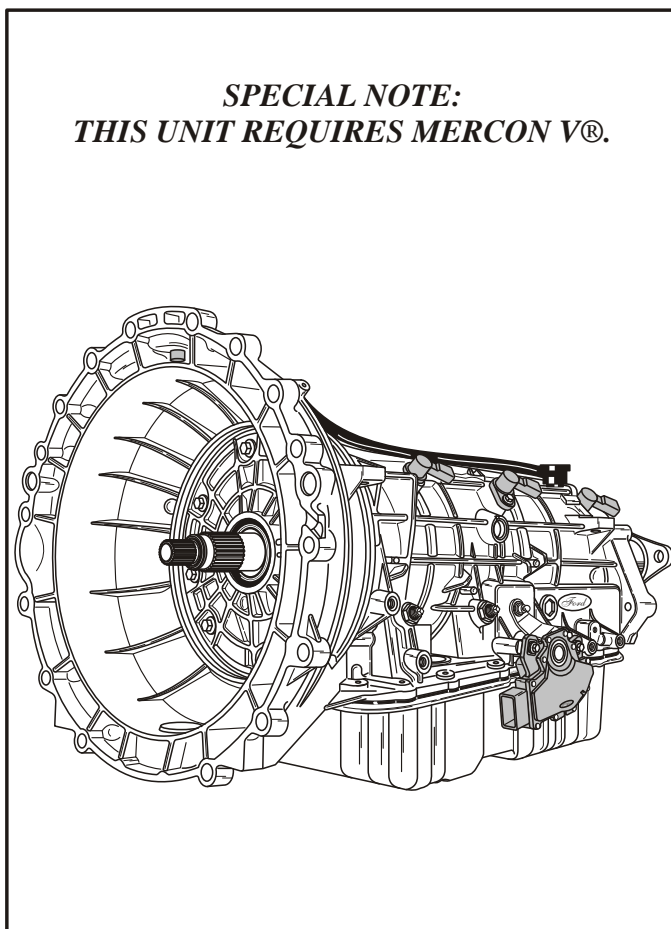

Figure 191

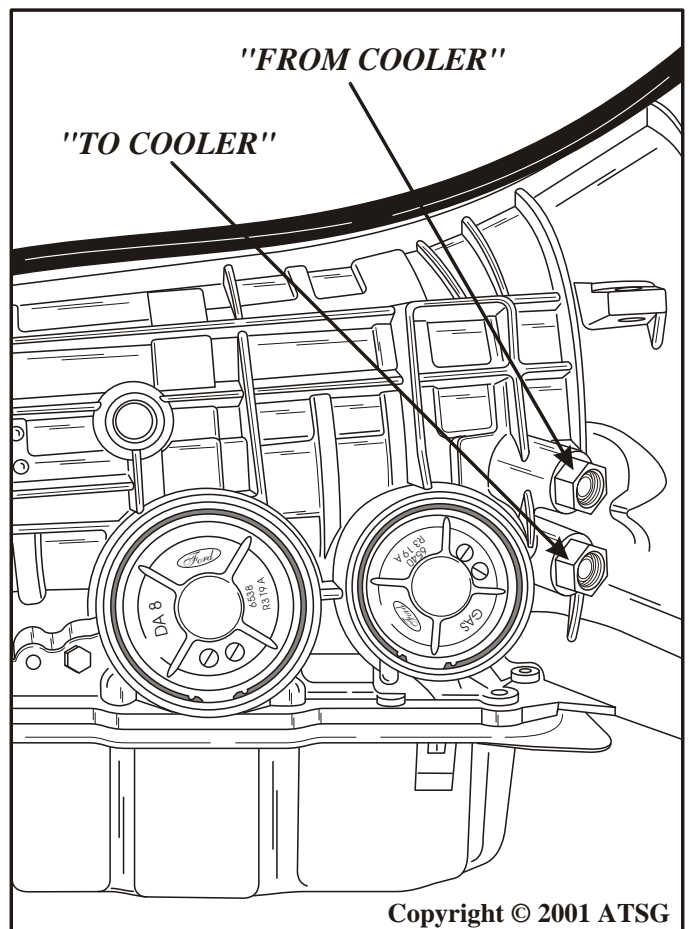

Figure 192

CHECKING FLUID LEVEL

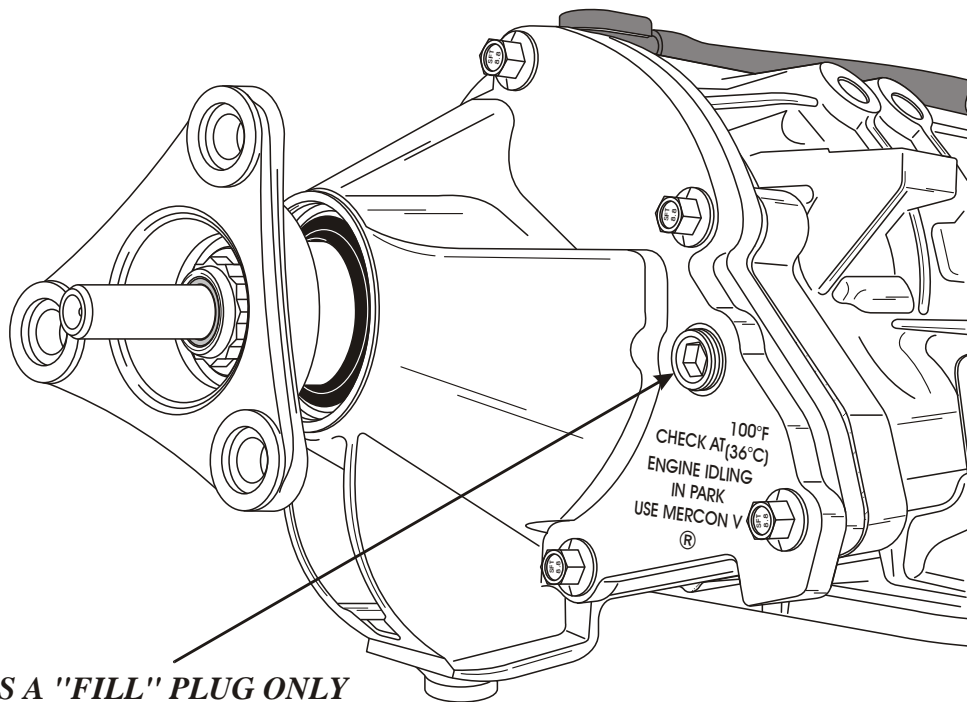
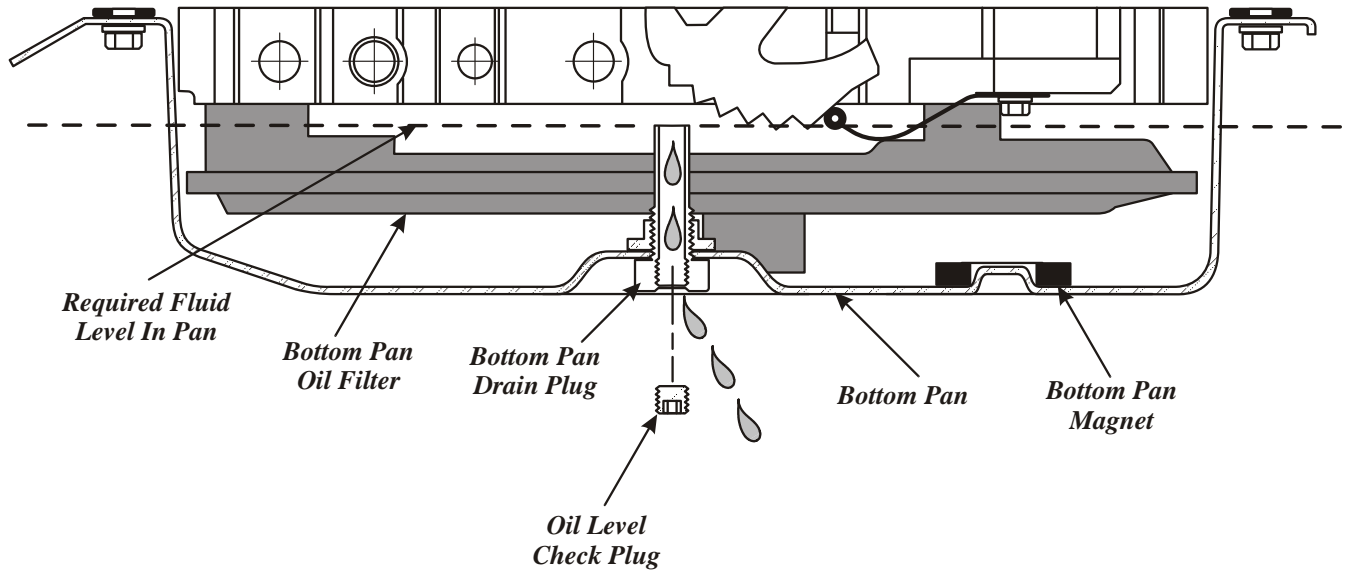
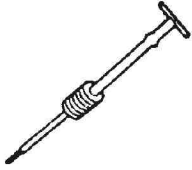

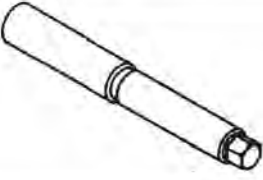
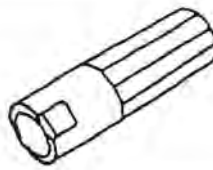
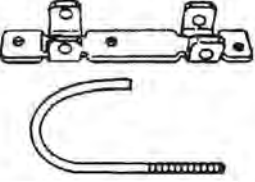

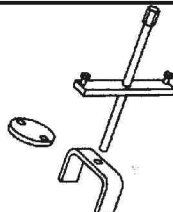







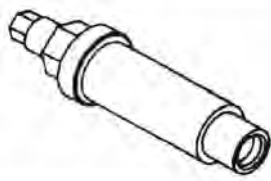



Figure 193

SPECIAL SERVICE TOOLS FORD OR "ROTUNDA" PART NUMBERS ARE REFERENCED

	<p>IMPACT SLIDE HAMMER 100-001 (T50T-100-A)</p>		<p>OIL PUMP ALIGNMENT TOOL 307-S039 (T74P-77103-X)</p>
	<p>OUTPUT SHAFT FLANGE INSTALLER 307-404</p>		<p>PUMP GEAR "O" RING SIZER 307-338 (T95L-700-10-G)</p>
	<p>SERVO COVER COMPRESSOR 307-402</p>		<p>DIAL INDICATOR 100-002 (TOOL-4201-C)</p>
	<p>INT CUSHION SPRING COMPRESSOR 307-401</p>		<p>TRS ALIGNMENT TOOL 307-351 (T97L-70010-A)</p>
	<p>OIL PUMP ALIGNMENT DOWELS 307-399</p>		<p>DEPTH MICROMETER 303-D206 (D8OP-4201-A)</p>
	<p>RETAINING RING PLIERS 307-343 (T95P-77001-AHR)</p>		<p>OUTPUT SHAFT BEARING INSTALLER 307-348 (T97T-77110-A)</p>
	<p>VALVE BODY GUIDE PIN (.248") 307-334 (T95L-70010-C) (2 REQUIRED)</p>		<p>BEARING REMOVER 308-047 (T77F-1102-A)</p>
	<p>OUTPUT FLANGE INSTALLER 205-479</p>		<p>BAND ADJUSTMENT TOOL 307-S022 (T71P-77370-A)</p>

Copyright © 2001 ATSG

Figure 194

SPECIAL SERVICE TOOLS
FORD OR "ROTUNDA" PART NUMBERS ARE REFERENCED



 <p>EXTENSION HOUSING SEAL INSTALLER 307-038 (T74P-77052-A)</p>	 <p>FORWARD CLUTCH INNER LIP SEAL PROTECTOR 307-051 (T74P-77548-A)</p>
 <p>COAST AND DIRECT CLUTCH INNER LIP SEAL PROTECTOR 307-049 (T74P-77404-A)</p>	 <p>FORWARD CLUTCH OUTER LIP SEAL PROTECTOR 307-052 (T74P-77548-B)</p>
 <p>FRONT PUMP SEAL INSTALLER 307-349 (T97T-77000-A)</p>	 <p>AIR TEST PLATE 307-405</p>
 <p>FRONT PUMP REMOVAL TOOL 307-397</p> <p><i>A very acceptable alternative for this tool is available from Trans-Tool in San Antonio and is universal so it works on many other models. Their part number is T-0033.</i></p>	 <p>UNIVERSAL PULLER 307-001 (TOOL-1175-AC)</p>  <p>OUTPUT FLANGE REMOVAL TOOL 307-408</p>
	<p align="right">Copyright © 2001 ATSG</p>

Figure 195

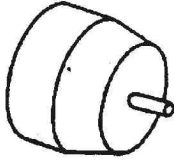
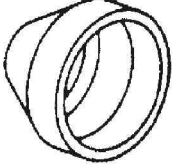

Technical Service Information

TORQUE SPECIFICATIONS			
Description	Nm	In.Lb.	Ft.Lb.
Pump Stator To Pump Cover	25		18
Spacer Plate Retaining Bolts	10	89	
Inside Detent Lever Nut	48		35
Oil Pump To Case Bolts	25		18
Center Support Bolt	11	100	
Valve Body Bolts	10	89	
Valve Body Cover Bolts	10	89	
Solenoid Body Bolts	8	71	
Reverse Servo Bolts	10	89	
Filter Bolts	10	89	
Bottom Pan Bolts	11	100	
Extension Housing Bolts	39		29
Output Flange Retaining Nut	131		97
Transmission Range Sensor	10	89	
Speed Sensors	10	89	

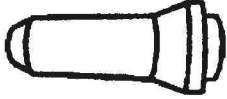
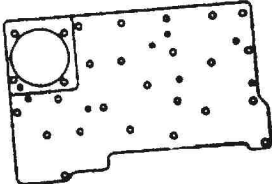
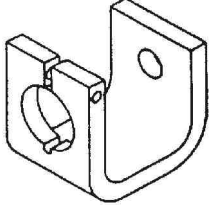
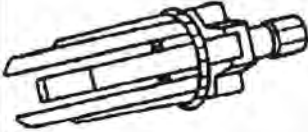
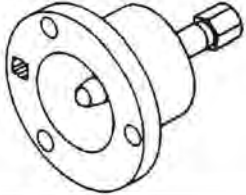
Figure 196

***A VERY HEARTY "THANK YOU" TO LEON AUTRY OF
A & REDS TRANSMISSION PARTS
FOR SUPPLYING US WITH THE TRANSMISSION THAT MADE
THE ILLUSTRATIONS IN THIS BOOKLET POSSIBLE.***

A & REDS TRANSMISSION PARTS

***PLEASE FEEL FREE TO CALL TODAY
1 800 835-1007***

***WE HAVE WHAT YOU NEED FOR
"ALL" YOUR TRANSMISSION NEEDS!***

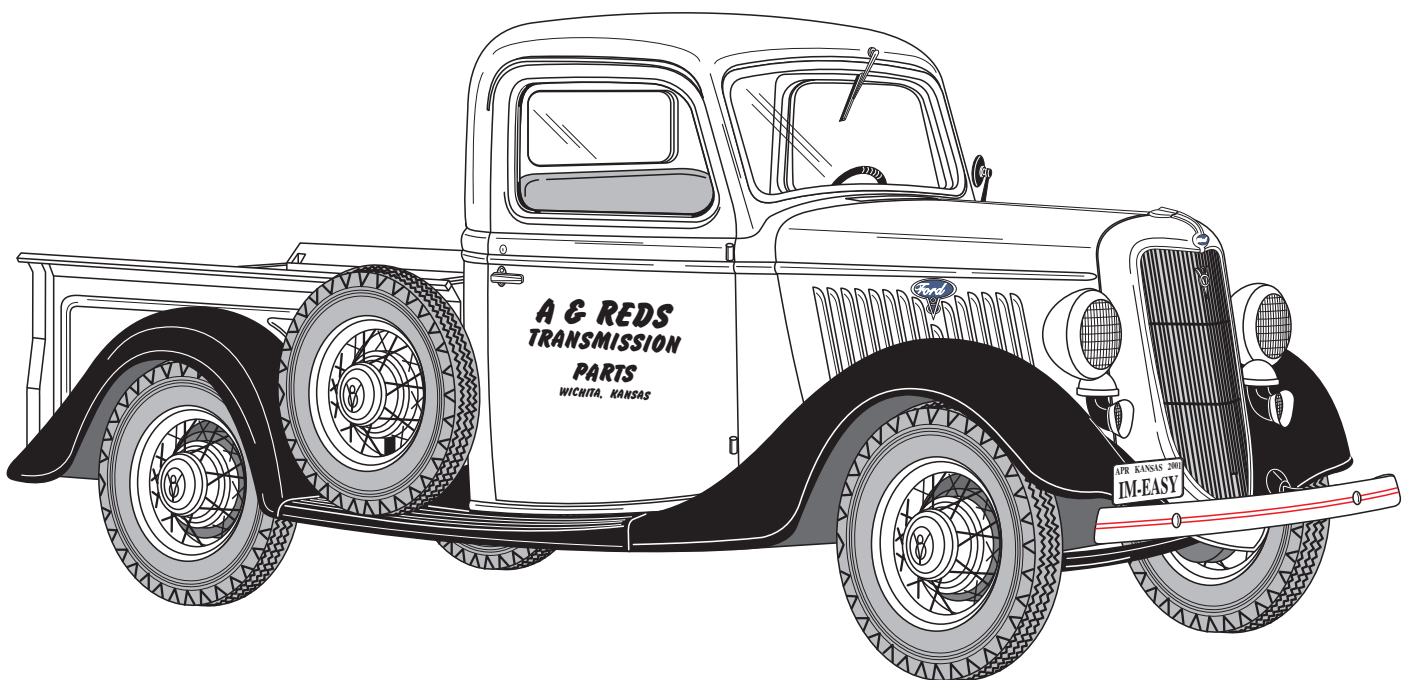

Copyright © 2001 ATSG



FORD 5R55N REVISED CHECKBALL LOCATIONS

CHANGE: Ford Motor Co. eliminated one of the checkballs in the 5R55N transmission as a running change during the 2000 model year. Early version, which requires 3 checkballs, is illustrated in Figure 1, and the late version, requires 2 checkballs, as shown in Figure 2.

REASON: Improved driveability and pleaseability.

PARTS AFFECTED:

- (1) VALVE BODY CASTING - The valve body casting changed in the location of the checkball that was eliminated, as shown in Figure 1 and 2.
- (2) VALVE BODY SPACER PLATE - The valve body spacer plate was modified to accommodate the elimination of the one checkball, as shown in Figure 1 and 2.

INTERCHANGEABILITY:

The spacer plates "Cannot" be interchanged between the early and late style valve bodies.

The "Late Style" valve body and spacer plate as a package will retro-fit back on all models of the 5R55N transmission and is recommended.

"EARLY STYLE" 3 CHECKBALL VALVE BODY AND SPACER PLATE

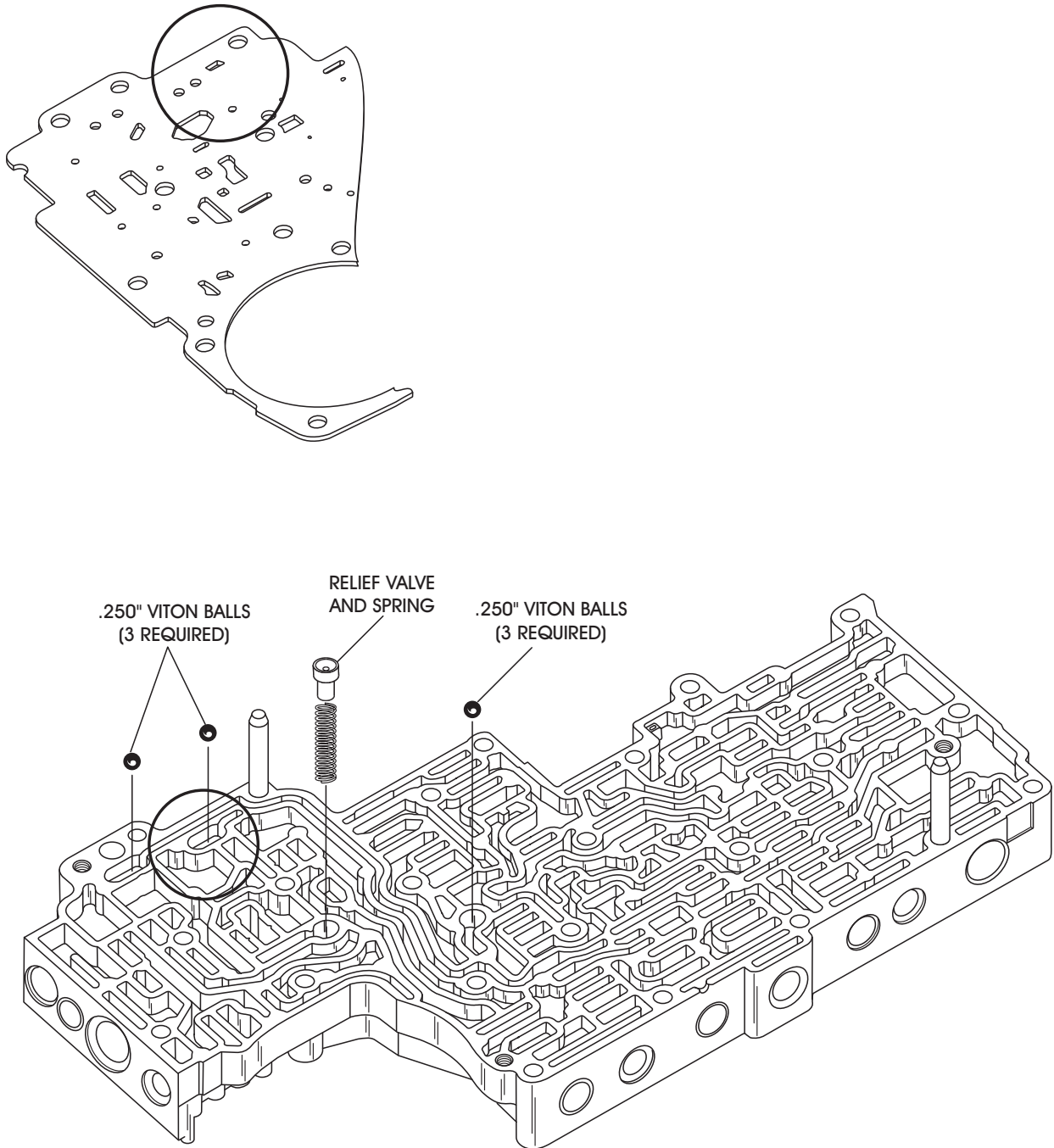

Copyright © 2005 ATSG

Figure 1

"LATE STYLE" 2 CHECKBALL VALVE BODY AND SPACER PLATE

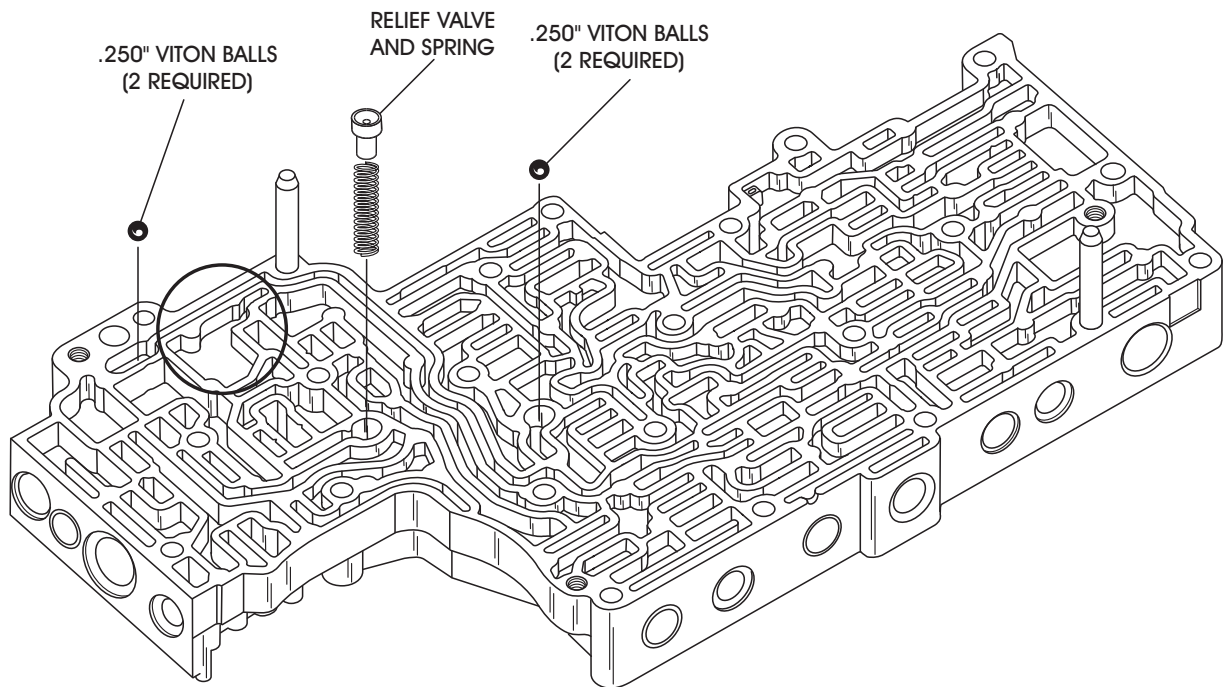
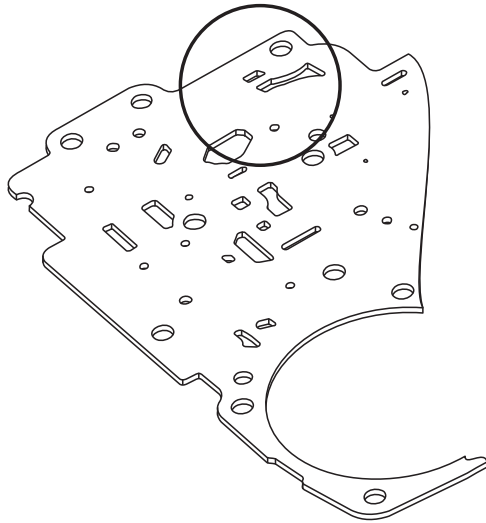

Copyright © 2005 ATSG

Figure 2