

2004 S-TYPE - Engine Cooling - 303-03A

Engine Cooling

Vehicles with 2.5L or 3.0L engine

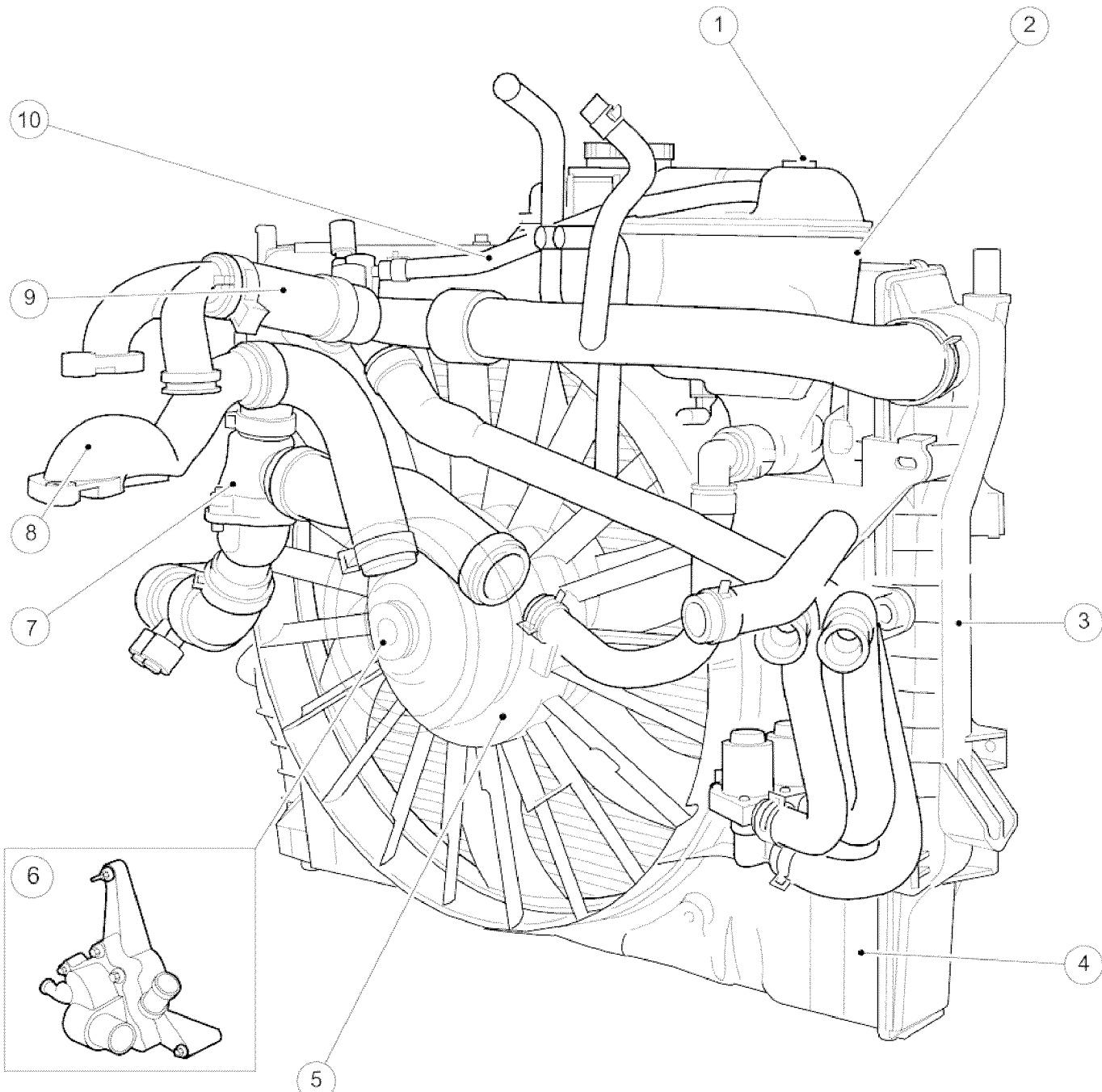

E30952

Item **Description**

2004 S-TYPE - Engine Cooling - 303-03A

1	Bleed screw
2	Coolant expansion tank
3	Radiator
4	Radiator shroud
5	Cooling fan motor
6	Water pump
7	Thermostat housing
8	Engine coolant inlet
9	Engine coolant outlet
10	Vent hose

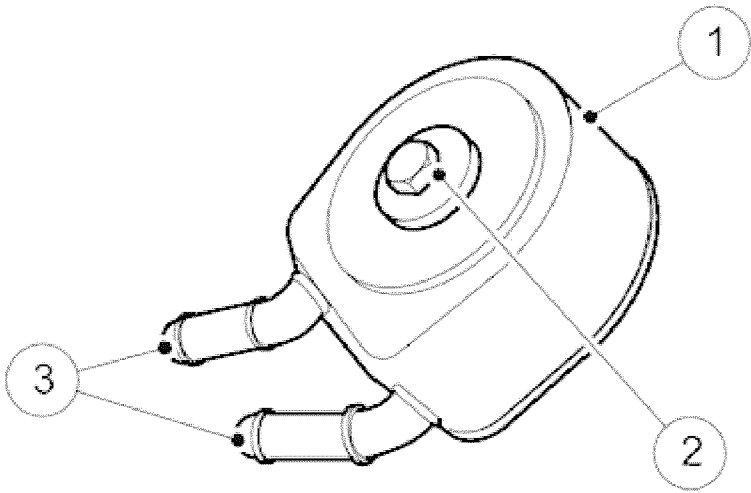

E31280

Item	Description
1	Engine oil cooler
2	Retaining bolt
3	Engine oil cooler inlet and outlet tubes

Vehicles with 4.2L engine

Vehicles with 4.2L engine without supercharger

2004 S-TYPE - Engine Cooling - 303-03A

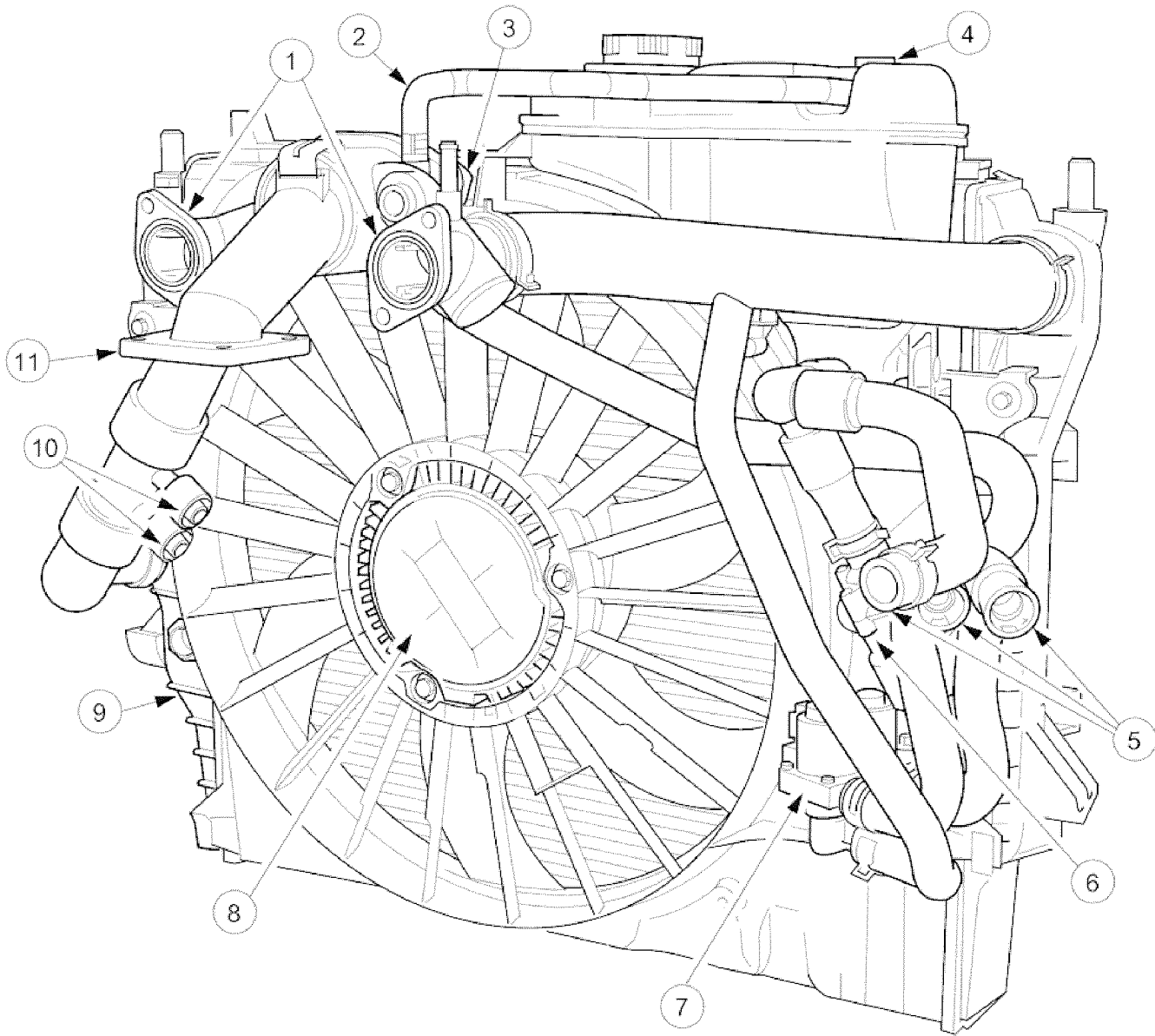

E30956

Item	Description
1	Engine coolant outlet
2	Vent hose
3	Thermostat housing
4	Bleed screw
5	Heater hose connections
6	Auxillary coolant flow pump
7	Dual coolant flow valve
8	Cooling fan motor
9	Radiator
10	Engine oil cooler connections
11	Engine coolant inlet

2004 S-TYPE - Engine Cooling - 303-03A

Vehicles with 4.2L engine with supercharger

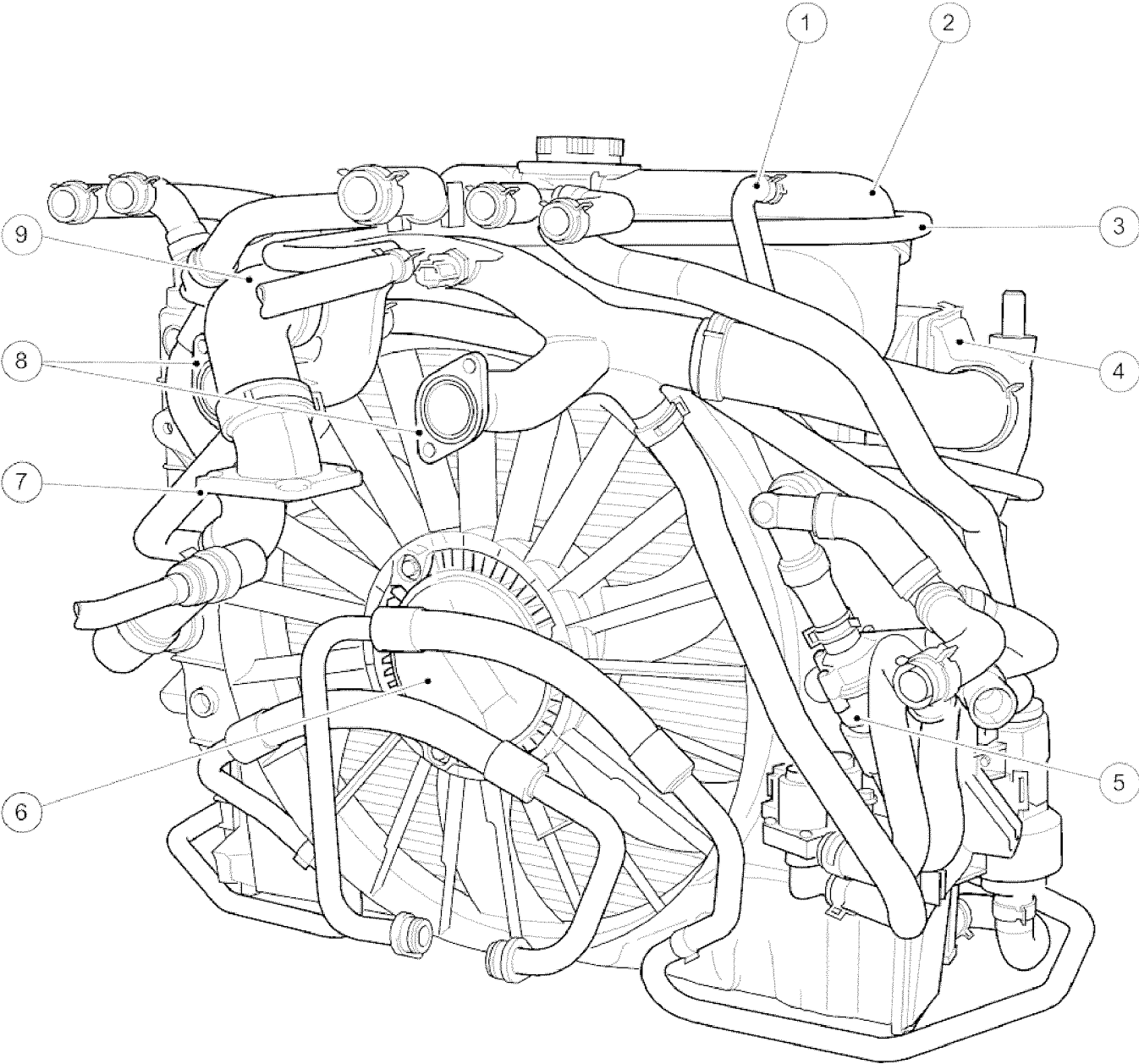

E30954
Item Description

2004 S-TYPE - Engine Cooling - 303-03A

1	Vent hose (SC radiator)
2	Coolant expansion tank
3	Vent hose
4	Radiator
5	Auxillary coolant flow pump
6	Cooling fan motor
7	Engine coolant inlet
8	Engine coolant outlet
9	Thermostat housing



WARNING:

NEVER REMOVE THE COOLANT PRESSURE CAP UNDER ANY CIRCUMSTANCES WHILE THE ENGINE IS OPERATING. FAILURE TO FOLLOW THIS INSTRUCTION MAY RESULT IN PERSONAL INJURY.

TO AVOID HAVING SCALDING HOT COOLANT OR STEAM BLOW OUT OF THE COOLING SYSTEM, USE EXTREME CARE WHEN REMOVING THE COOLANT PRESSURE CAP FROM A HOT COOLING SYSTEM. WAIT UNTIL THE ENGINE HAS COOLED, THEN WRAP A THICK CLOTH AROUND THE COOLANT PRESSURE CAP AND TURN IT SLOWLY UNTIL THE PRESSURE BEGINS TO RELEASE. STEP BACK WHILE THE PRESSURE IS RELEASED FROM THE SYSTEM. WHEN CERTAIN ALL THE PRESSURE HAS BEEN RELEASED (STILL WITH A CLOTH) TURN AND REMOVE THE COOLANT PRESSURE CAP FROM THE COOLANT EXPANSION TANK. FAILURE TO FOLLOW THESE INSTRUCTIONS MAY RESULT IN PERSONAL INJURY.



WARNING:

TO AVOID THE POSSIBILITY OF PERSONAL INJURY, DO NOT OPERATE THE ENGINE WITH THE HOOD OPEN UNTIL THE FAN BLADES HAVE BEEN EXAMINED FOR CRACKS AND SEPARATION. FAILURE TO FOLLOW THIS INSTRUCTION MAY RESULT IN PERSONAL INJURY.



WARNING:

REMOVE FUSE 38 FROM THE ENGINE COMPARTMENT FUSE BOX PRIOR TO PERFORMING ANY UNDER HOOD SERVICE IN THE AREA OF THE COOLING FAN WHEN THE ENGINE IS HOT, SINCE THE COOLING FAN MOTOR COULD OPERATE IF THE ENGINE HAS BEEN SWITCHED OFF. FAILURE TO FOLLOW THIS INSTRUCTION MAY RESULT IN PERSONAL INJURY.



CAUTION:

The engine cooling system must be maintained with the correct concentration and type of anti-freeze solution to prevent corrosion and frost damage.



CAUTION:

Never remove the coolant pressure cap under any circumstances while the engine is operating. Failure to follow this instruction may result in damage to the engine.

The cooling system consists of the following:

- Radiator
- Coolant pressure cap
- Thermostat
- Water pump
- Electric cooling fan
- Coolant expansion tank
- Engine oil cooler

2004 S-TYPE - Engine Cooling - 303-03A

Water Pump

The water pump is of a conventional design and is driven by the crankshaft pulley through the accessory drive belt. The water pump belt tension is maintained by an automatic drive belt tensioner. <<303-05>>

Thermostat

The thermostat is located in the thermostat housing and allows rapid engine warm-up by restricting coolant flow through the radiator below 82°C (180°F). The thermostat also assists in keeping the engine operating temperature within predetermined limits. On the 4.2L supercharged engine the thermostat begins to open at 84°C (183°F) and is fully open at 98°C (208°F), on the 4.2L and 2.5 or 3.0L engine the thermostat begins to open at 88°C - 92°C (190°F - 198°F) and is fully open at 102°C (216°F).

When the engine is cold and the thermostat is closed, coolant flows from the water pump through the engine. It then returns to the water pump through the upper coolant hose.

When the engine is warm and the thermostat is open, coolant flows into the radiator through the upper coolant hose. It then returns to the water pump from the radiator through the lower coolant hose and engine oil cooler.

The heater core is on a parallel circuit and is unaffected by the position of the thermostat.

Radiator

The radiator is of aluminium construction with plastic end tanks. Foam seals are fitted to the radiator to prevent the cooling air from by passing the radiator core. A coolant drain plug is provided in the lower coolant end tank of the radiator for the draining of the coolant. The Cooling fan shroud is attached to the radiator.

Cooling Fan

A single, variable speed cooling fan motor is attached to a fan shroud located behind the radiator. The speed is determined by the Engine Coolant Temperature (ECT) and the air conditioning pressure and transmission oil temperature.

Under hot operating conditions, the fan may continue to operate for four minutes after the engine has been switched off.

Engine Block Heater

For vehicle markets subject to very cold climate conditions, an engine block heater for connection to an external mains power supply, is fitted in place of the engine block drain plug.

Coolant Recovery System

A pressurized coolant expansion tank system is used which continuously separates the air from the cooling system and replenishes the system through the coolant expansion tank outlet hose, attached to the heater return hose.

A continuous vent from the engine and radiator to the coolant expansion tank prevents air locks from forming in the cooling system.

Manual bleed points are provided on the coolant reservoir.

The coolant expansion tank serves as the location for:

2004 S-TYPE - Engine Cooling - 303-03A

- Service fill.
- Coolant expansion during warm-up.
- Air separation during operation.
- System pressurization by the coolant pressure cap.
- The coolant expansion tank is designed to have approximately 0.5 to 1 liter of air when cold to allow for coolant expansion.

Engine Oil Cooler

The engine oil cooler is a Modine oil to water type. The oil cooler on the 2.5 or 3.0L engine is located on the left-hand side of the engine and is fitted to the oil filter housing. The oil cooler on the 4.2L engine is located at the front of the engine and is fitted between the oil filter housing and the oil filter.

The coolant supply for the engine oil cooler is through the radiator bottom hose.

Engine Coolant

The long life engine coolant is formulated to last for five years or 240,000 km (150,000 miles). The coolant is silicate free and orange in color. The long life engine coolant must not be mixed with conventional engine coolant.

Vehicles with 2.5L or 3.0L engine

2004 S-TYPE - Engine Cooling - 303-03A

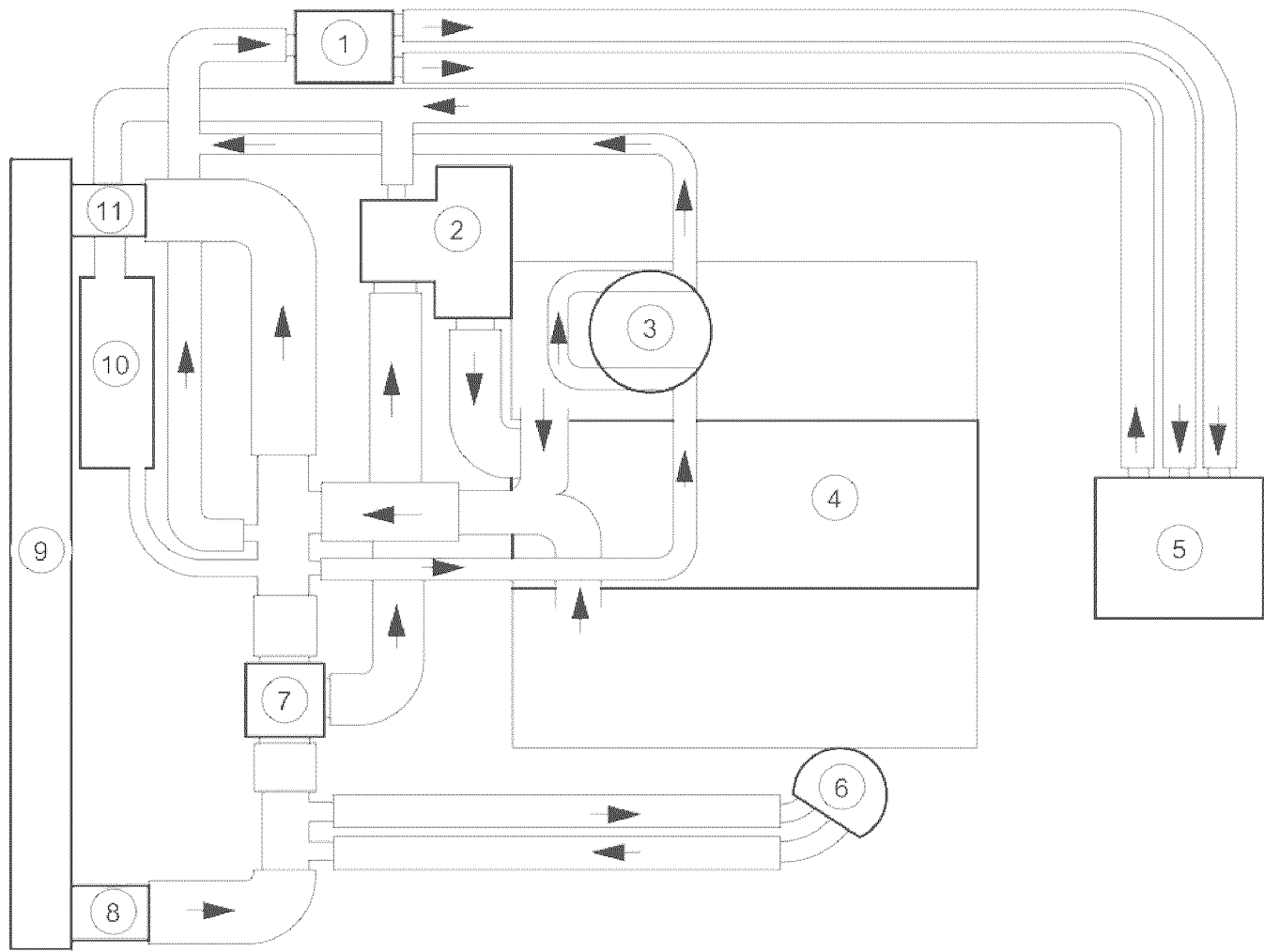

E30957

Item	Description
1	Dual coolant flow valve
2	Water pump
3	Throttle body
4	V6 engine
5	Heater core
6	Engine oil cooler
7	Thermostat
8	Lower hose
9	Radiator
10	Coolant expansion tank
11	Upper hose
12	Top hose

Vehicles with 4.2L engine

2004 S-TYPE - Engine Cooling - 303-03A

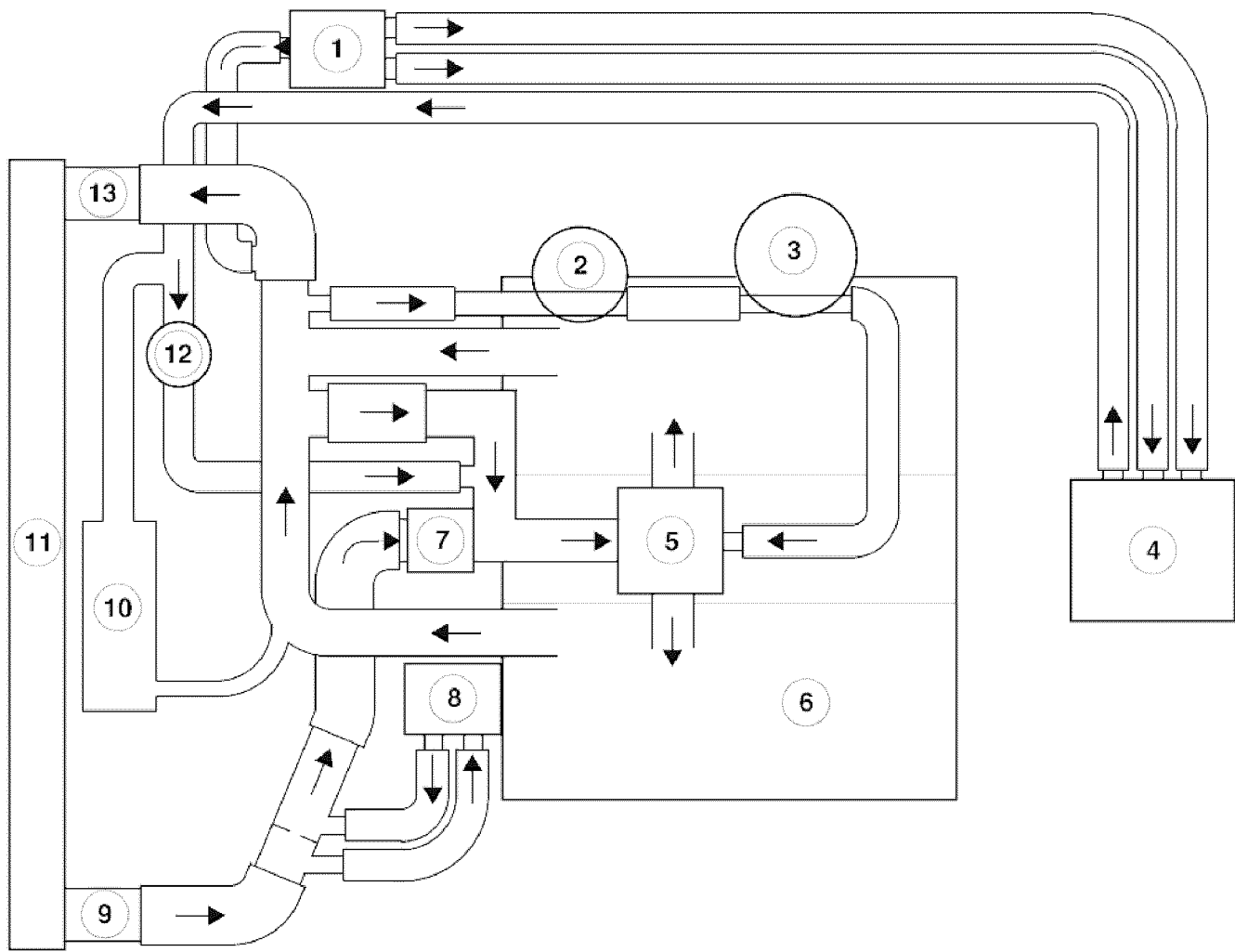

E30953

Item	Description
1	Dual coolant flow valve
2	EGR valve
3	Throttle body
4	Heater core
5	Water pump
6	Engine bank (left-hand)
7	Thermostat
8	Engine oil cooler
9	Lower hose
10	Coolant expansion tank
11	Radiator
12	Auxiliary coolant flow pump
13	Upper hose

2004 S-TYPE - Engine Cooling - 303-03A

Vehicles with 4.2L engine with supercharger

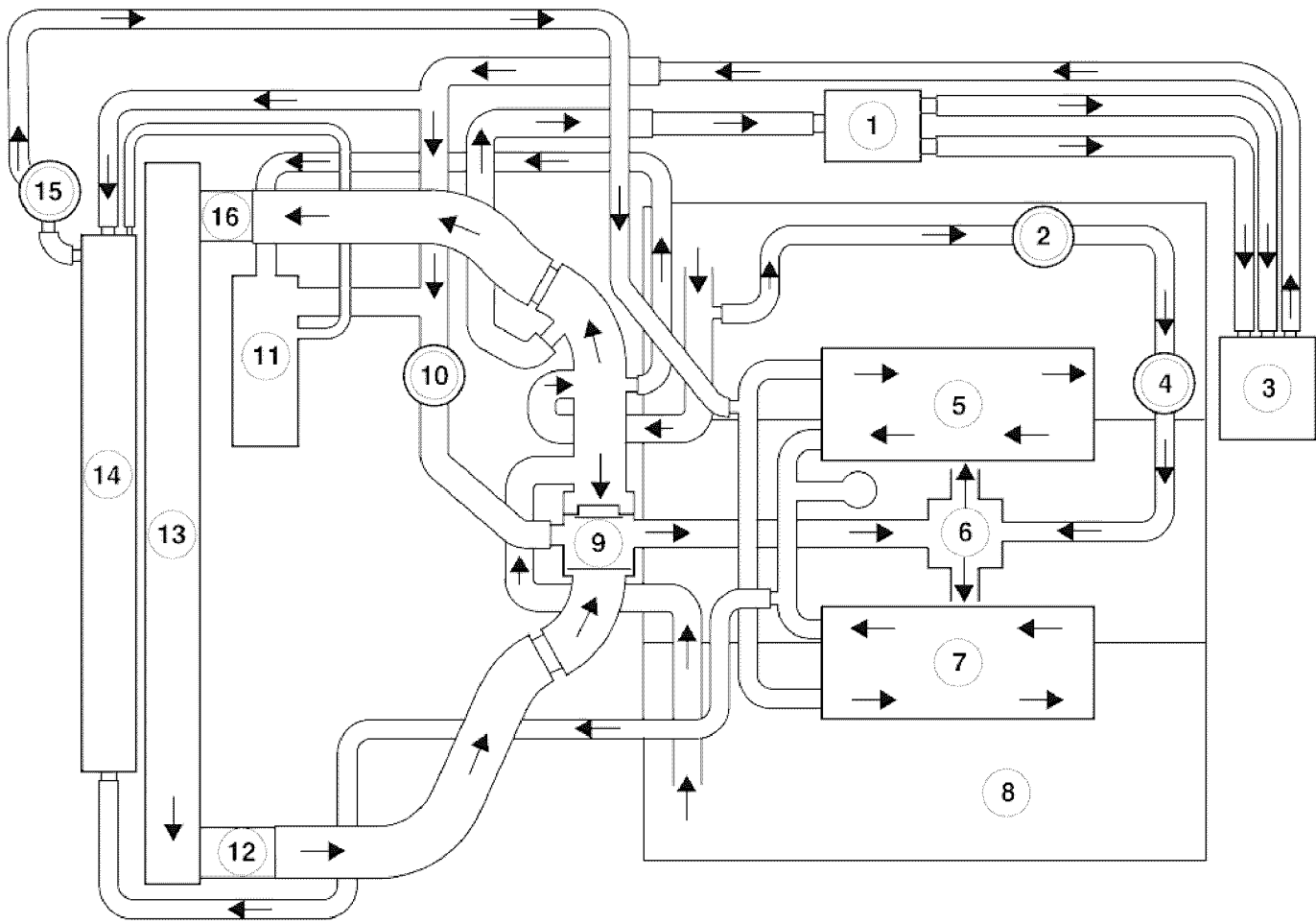

E30955

Item Description

2004 S-TYPE - Engine Cooling - 303-03A

1	Dual coolant flow valve
2	EGR valve
3	Heater core
4	Throttle body
5	Charge air cooler (right-hand)
6	Water pump
7	Charge air cooler (left-hand)
8	Engine bank (left-hand)
9	Thermostat
10	Auxiliary coolant flow pump
11	Coolant expansion tank
12	Lower hose
13	Radiator
14	SC radiator
15	SC coolant pump
16	Upper hose