



MODEL
XK, XJ,
S-TYPE

DATE
17 Apr 2007

NUMBER
JTB00034

SERVICE

TECHNICAL BULLETIN

SECTION: 100-04

Noise when Turning Steering Wheel

AFFECTED VEHICLE RANGE:

XJ	VIN: G41427 to H15491
S-TYPE	VIN: N38511 to N80136
XK (X150)	VIN: B00379 to B13633

CONDITION SUMMARY:

STEERING COLUMN ADJUSTMENT TO RESOLVE NOISE

Situation: Increased loading on the bulkhead bushing can result in noise coming from the steering column when the steering wheel is turned.

Action: If a customer expresses concern about the steering noise symptoms and they are verified, reposition the lower steering column to release pressure on the bulkhead bushing as outlined below in the Repair Procedure of this bulletin.

PARTS:

△ NOTE: The "KSP205" lubricant is used from the Squeaks and Rattles kit JLM21204.
C2C 2918.....Bolt Qty 2

WARRANTY:

△ NOTE: Repair procedures are under constant review, and therefore times are subject to change; those quoted here must be taken as guidance only. Always refer to DDW to obtain the latest repair time.

△ NOTE: An allowance equivalent to US\$5.00 may be claimed in local currency quoting sundry item code (ROW) ZZZ001, NAS ('other') for the parts used from JLM21204.

DDW requires the use of causal part numbers. Labor only claims must show the causal part number with a quantity of zero.

<i>Description</i>	<i>SRO</i>	<i>Time (Hours)</i>	<i>Condition Code</i>	<i>Causal Part</i>
Reposition lower steering column - XJ Range	57.91.34	0.50	41	C2C 2918
Reposition lower steering column - S-TYPE	57.91.34	0.60	41	C2C 2918
Reposition lower steering column - New XK	57.91.34	0.50	41	C2C 2918

Normal warranty policy and procedures apply.

NOTE: The information in Technical Bulletins is intended for use by trained, professional technicians with the knowledge, tools, and equipment required to do the job properly and safely. It informs these technicians of conditions that may occur on some vehicles, or provides information that could assist in proper vehicle service. The procedures should not be performed by "do-it-yourselfers." If you are not a Retailer, do not assume that a condition described affects your vehicle. Contact an authorized Jaguar service facility to determine whether the bulletin applies to a specific vehicle.

REPAIR PROCEDURE

LUBRICATION OF STEERING PLATE

1. If the vehicle is an S-TYPE, perform the following steps:
 - Centralize the steering wheel and secure in place with a suitable brace.
 - Raise the vehicle on a lift.
 - Remove floor undertray.
 - Remove the upper steering column pinch bolt. (Figure 1)
 - Detach the lower steering column universal joint from the steering gear. (Figure 2)
 - Lower the vehicle on the lift.
 - Detach the lower steering column shaft from the upper steering column. (Figure 3)
 - Remove the lower steering column support bearing retaining nuts. (Figure 4)
 - Remove the lower steering column. (Figure 5)

△ **NOTE: Global Technical Reference (GTR) lookup sequence is as follows:**
GTR Home > NAS > Service Information/ X350 - XJ/2006 > Workshop Manuals > Bookmark "Chassis/Steering System/ 211-04 – Steering Column" Link "Steering Column Lower Shaft"

2. If the vehicle is an XJ or New XK vehicle, refer to GTR Workshop Manual, section: 211-04 (57.40.05) and remove the steering column lower shaft.

△ **NOTE: Bearing faults are to be carried out as a separate Warranty claim.**

3. Slide the bearing up the column and check the bearing condition.
4. If there is a fault with the bearing, repair the fault and claim separately.

Figure 1

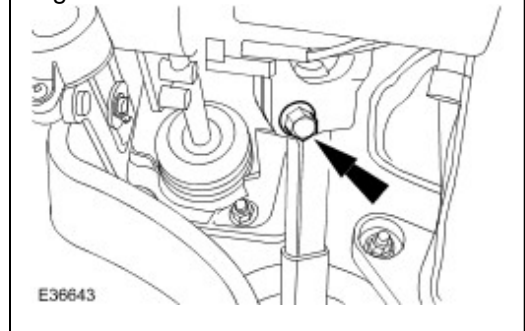

Figure 2

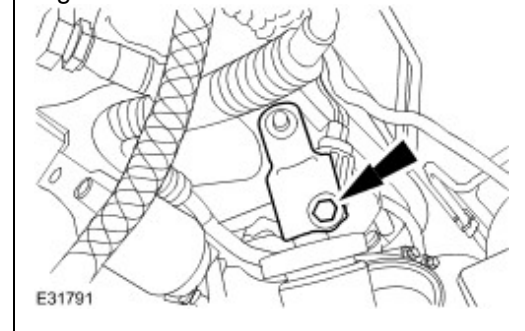

Figure 3

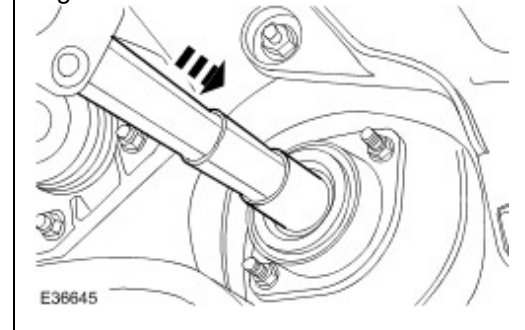

Figure 4

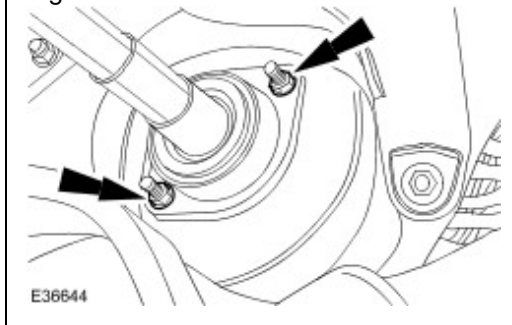
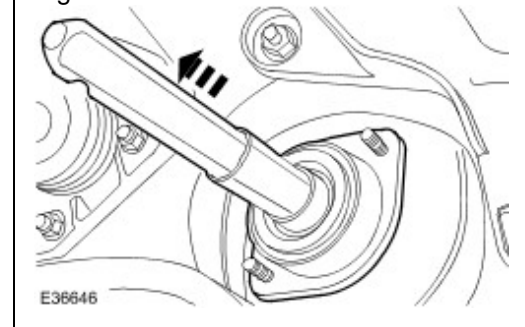

Figure 5





NOTE: Knuckle faults are to be carried out as a separate Warranty claim.

5. Check condition of the lower knuckle joint.
6. If there is a fault with the knuckle, repair the fault
7. Slide back the steering column retaining plate to gain access to the retaining plate rubber.
8. Grease the retaining plate rubber using two packs of KSP205 from the Squeaks and Rattles Kit (JLM21204). (Figure 6)

INSTALL AND ADJUST STEERING COLUMN

1. Place lower column to the vehicle.
2. If the vehicle is an XJ or New XK vehicle, refer to GTR Workshop Manual, section: 211-04 (57.40.05) to install and align the steering column lower shaft.
3. If the vehicle is an S-TYPE perform the following:
 - Install and align the lower steering column.
 - Install and tighten the lower steering column support bearing securing nuts to 9Nm (xx lbf.ft).
 - Reposition the lower column to the upper column.
 - Install and tighten the new pinch bolt to 35Nm. (xx lbf.ft).
4. Raise the vehicle on the lift.
5. Install and align the lower column to the steering gear.
6. Reposition the lower steering column swinging link to its lowest position. (Figure 7 for XK and Figure 8 for XJ and S-TYPE) .

Figure 6

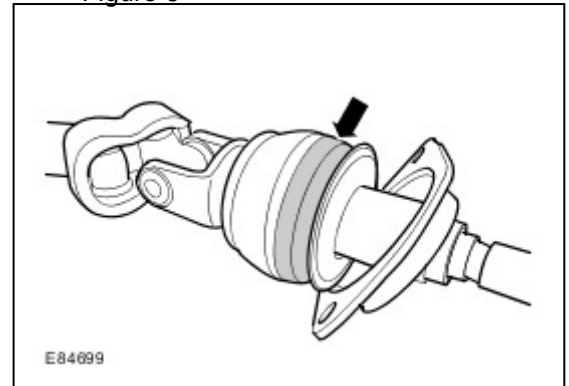

Figure 7

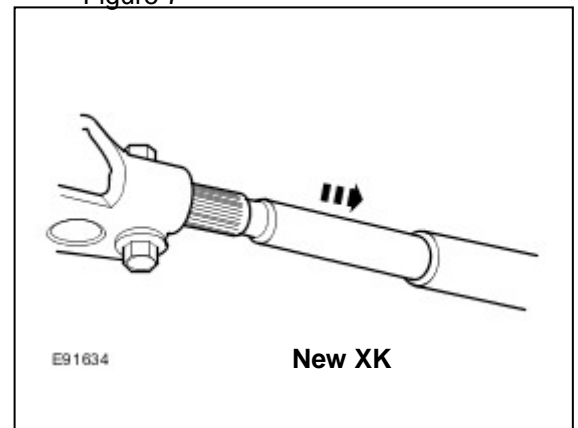
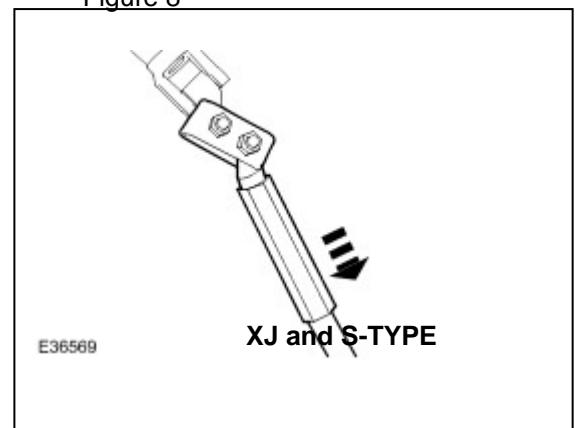

Figure 8



7. Mark the position of the steering column lower shaft relative to the universal joint. (Figure 9)
8. Reposition the lower column swinging link to its highest position. (Figure 10 for New XK and Figure 11 for XJ and XJ and S-TYPE)
9. Move the steering column lower shaft until the measurement between the mark on the steering column lower shaft and the top of the universal joint is 7mm. (Figure 12)
10. Fully tighten the new lower column pinch bolt, install the new fastener and tighten to 35Nm. (Figure 13)
11. Install the floor undertray.
12. Lower the vehicle on the lift.

