



Technical Service Bulletin

No.JTB00034v3
21 June 2007

Reissue

Please replace the previous edition of this bulletin.

This bulletin supersedes TSB JT B00034v2/2007 dated 01 May, which should either be destroyed or clearly marked to show it is no longer valid (e.g. with a line across the page).

Subject/Concern: Noise When Turning Steering Wheel

Models:

XJ Range		VIN-range: G41427-H15491
S-TYPE		VIN-range: N38511-N80136
The New XK		VIN-range: B00379-B13633

Markets: All

Section: 100-04

Summary:

Noise emanating from the steering column when turning the steering wheel.

This Version of the bulletin has been issued for a change in the Service Instruction.

Cause: Increased loading on the bulkhead bushing.

Action: Should a customer express concern, reposition the lower steering column to release pressure on the bulkhead bushing. Follow the Service Instruction outlined below.

NOTE: An allowance equivalent to £2.60 sterling may be claimed in local currency quoting sundry item code (ROW) ZZZ001, NAS ('other') for the parts used from JLM21204.

Parts Required:

Description	Part Number	Quantity
Bolts	C2C 2918	2

Labour Time:

Operation Description	Operation No.	Time
Reposition lower steering column - XJ Range	57.91.34	0.5 hours
Reposition lower steering column - S-TYPE	57.91.34	0.6 hours
Reposition lower steering column - New XK	57.91.34	0.5 hours

Repair/Claim Coding:	
Causal Part:	C2C 2918
ACES Condition Code:	41
Defect Code:	

Service Instruction

On XJ Range and New XK Vehicles

1. Remove Steering Column Lower Shaft (see Global Technical Reference GTR Workshop Manual, section: 211-04 (57.40.05)) then carry on from step 12.

On S-TYPE Vehicles

2. Centralize the steering wheel.

Vehicles with locking steering column only

3. Lock the steering column by removing the ignition key.
4. Raise the vehicle on a lift.
5. Remove floor undertray.
6. Remove the upper steering column pinch bolt.

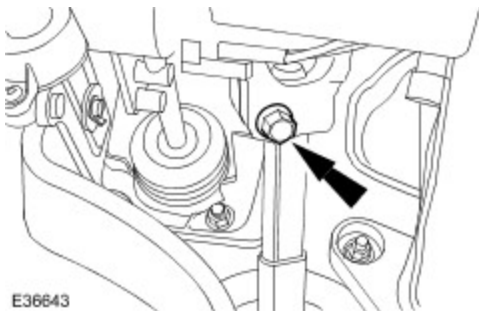

7. Detach the lower steering column universal joint from the steering gear.

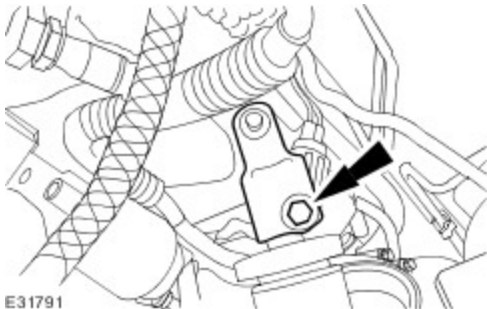

8. Lower the vehicle on the lift.
9. Detach the lower steering column shaft from the upper steering column.

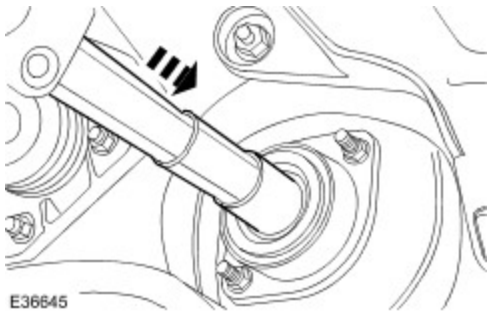

- 10 . Remove the lower steering column support bearing retaining nuts.

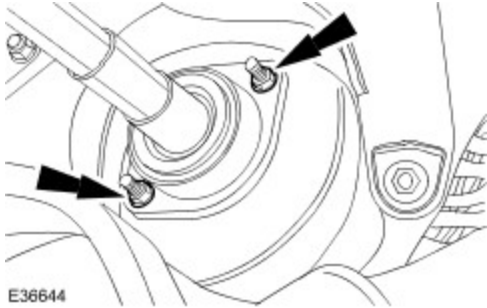

- 11 . Remove the lower steering column.

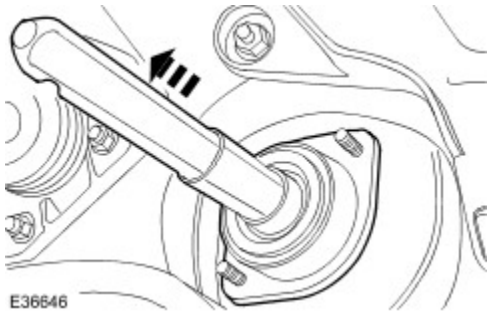

- 12 . **NOTE:** If there is a fault with the bearing, repair the fault (to be carried out as a separate Warranty claim).

Slide the bearing up the column and check the bearing condition.

- 13 . **NOTE:** If there is a fault with the knuckle, repair the fault (to be carried out as a separate Warranty claim).

Check condition of the lower knuckle joint.

- 14 . Slide back the steering column retaining plate to gain access to the retaining plate rubber.
15 . Grease the retaining plate rubber (using KSP205 x 2 from the Squeaks and Rattles Kit (JLM21204)).

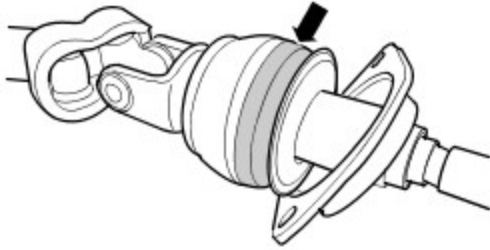

E84699

- 16 . Place lower column to the vehicle.

New XK Vehicles

- 17 . **NOTE:** When installing lower shaft follow steps below for XK Vehicles.

Install the Steering Column Lower Shaft (see Global Technical Reference GTR Workshop Manual, section: 211-04 (57.40.05)).

- 18 . Install and align the lower steering column.
- 19 . Install and tighten the lower steering column support bearing securing nuts to 9Nm.
- 20 . Reposition the lower column to the upper column, secure the new pinch bolt, install the new fastener and tighten to 35Nm.
- 21 . Raise the vehicle on the lift.
- 22 . Install and align the lower column to the steering gear.

New XK Vehicles and S-TYPE Vehicles

- 23 . Reposition the lower steering column to its lowest position.

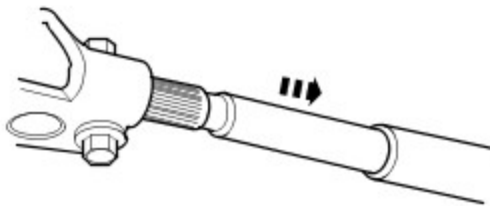

E91634

On XJ Range Vehicles

- 24 . Reposition the lower steering column swinging link to its lowest position.



On All Vehicles

25 . Mark the position of the steering column lower shaft relative to the universal joint.

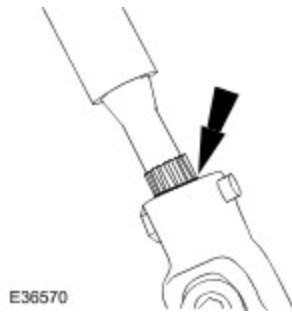

New XK Vehicles and S-TYPE Vehicles

26 . Reposition the lower column swinging link to its highest position.

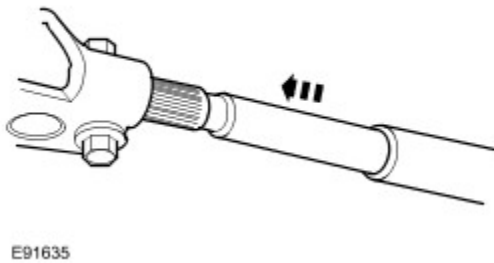

On XJ Range Vehicles

27 . Reposition the lower column swinging link to its highest position.

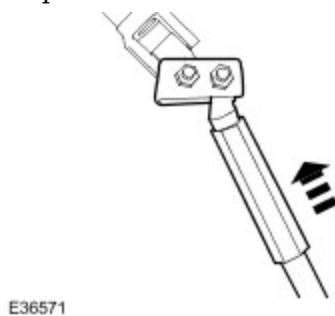

On All Vehicles

- 28 . Move the steering column lower shaft until the measurement between the mark on the steering column lower shaft and the top of the universal joint is 7mm.

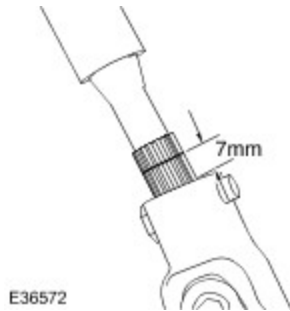

- 29 . Fully tighten the new lower column pinch bolt, install the new fastener and tighten to 35Nm.

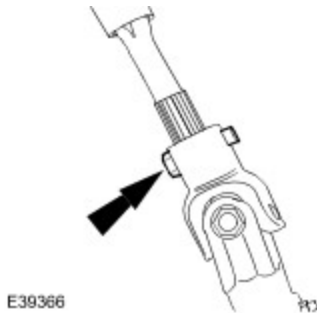

- 30 . Install the floor undertray.
31 . Lower the vehicle on the lift.

©2007 Jaguar