

Transmission Selector Lever 44.15.04

Removal

1. Place the transmission selector lever to the 'R' position.
2. Remove the parking brake switch. <<206-05>>

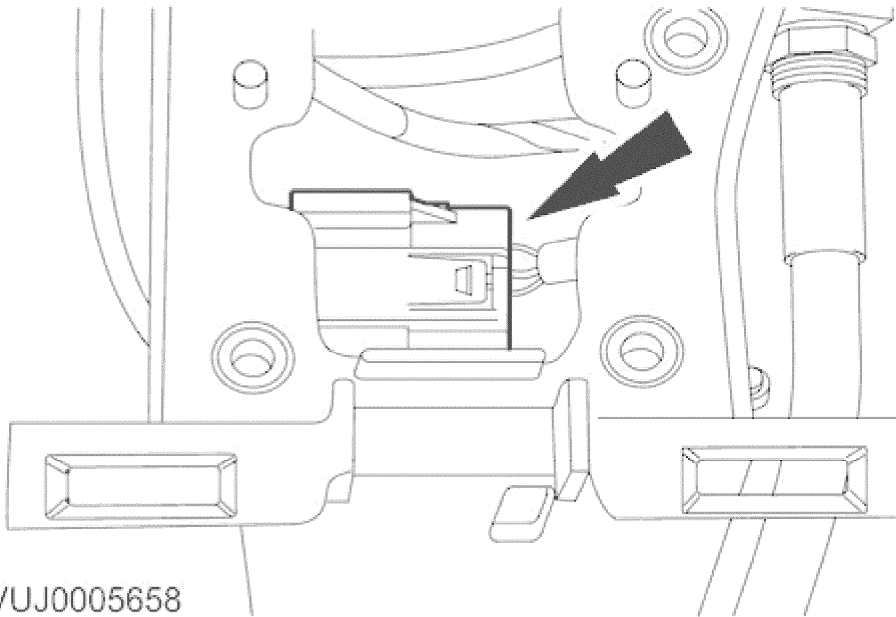

VUJ0005658

3. Disconnect the electrical connector.

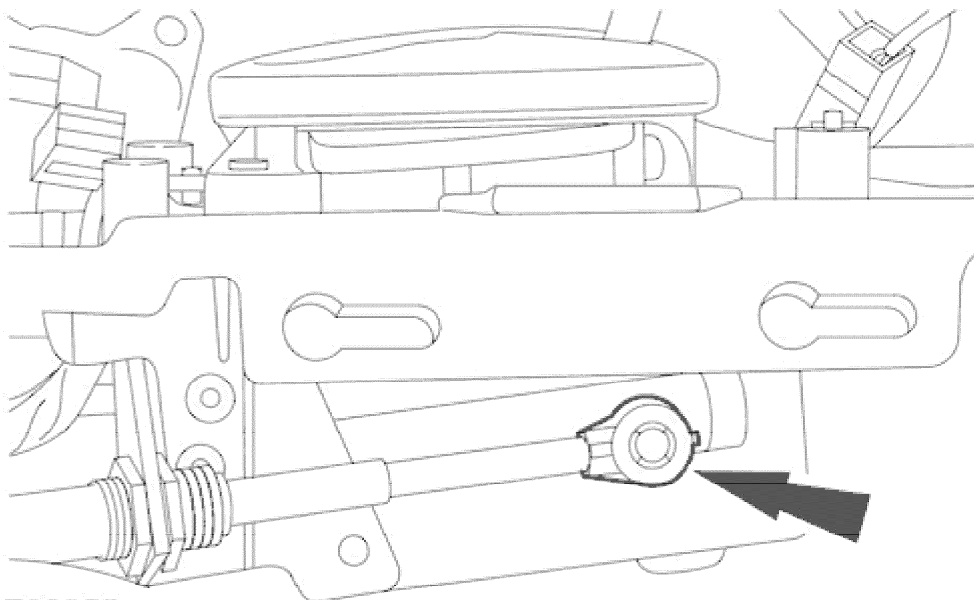

E30355

4. Detach the selector lever cable.

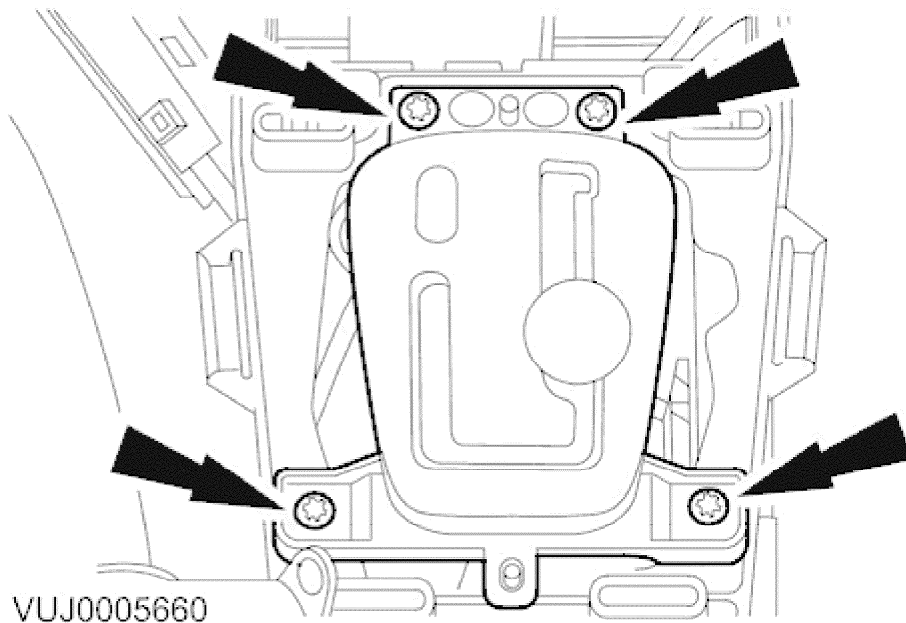

5. Detach the transmission selector lever.
• Remove the retaining bolts.

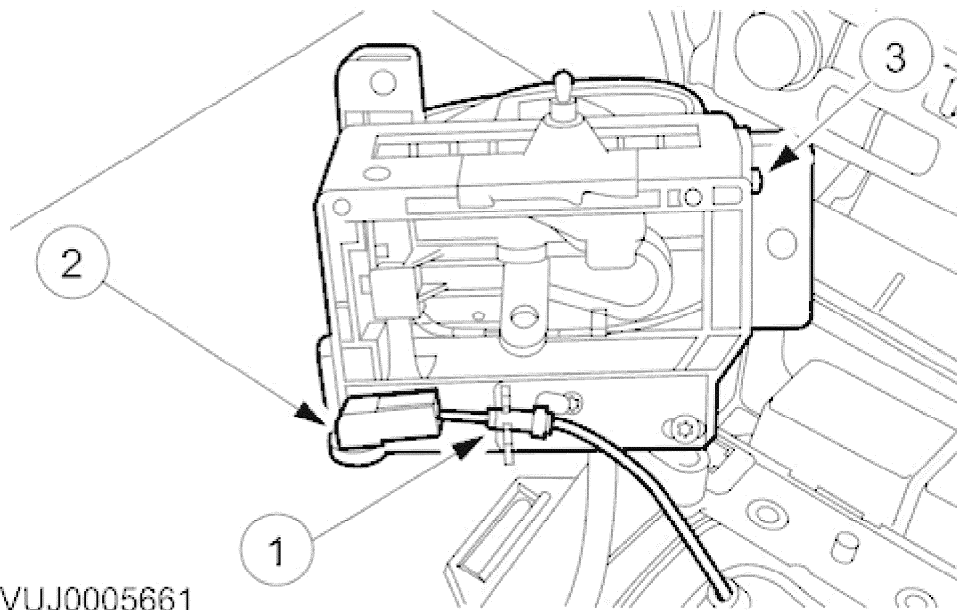

6. Remove the transmission selector lever.
1. Detach the ignition switch interlock cable.
2. Disconnect the ignition switch interlock cable.
3. Remove the transmission selector lever.

Installation

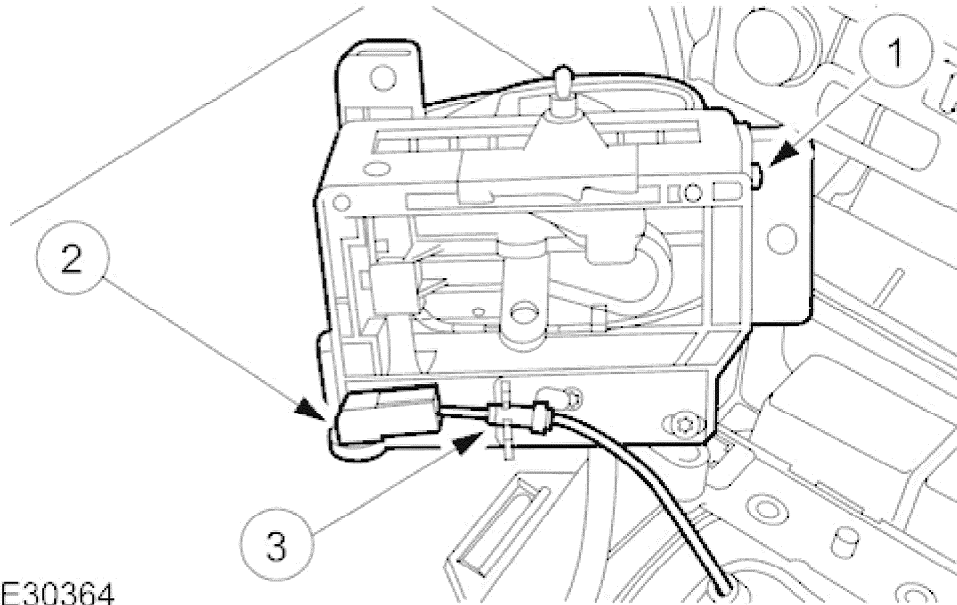

E30364

1. Attach the ignition switch interlock cable.
 1. Install the transmission selector lever.
 2. Connect the ignition switch interlock cable.
 3. Attach the ignition switch interlock cable.

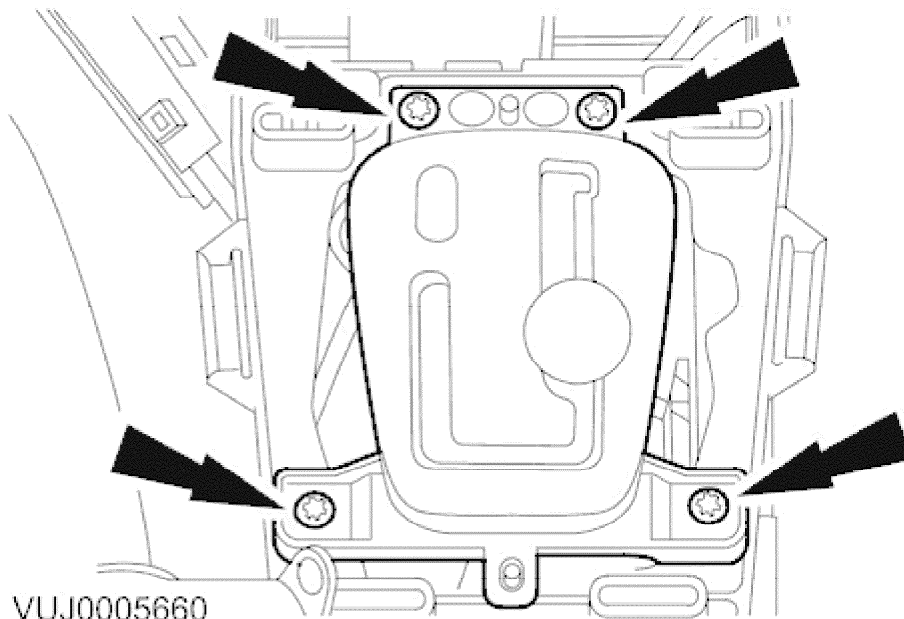

VUJ0005660

2. Attach the transmission selector lever.
 - Tighten to 11 Nm.

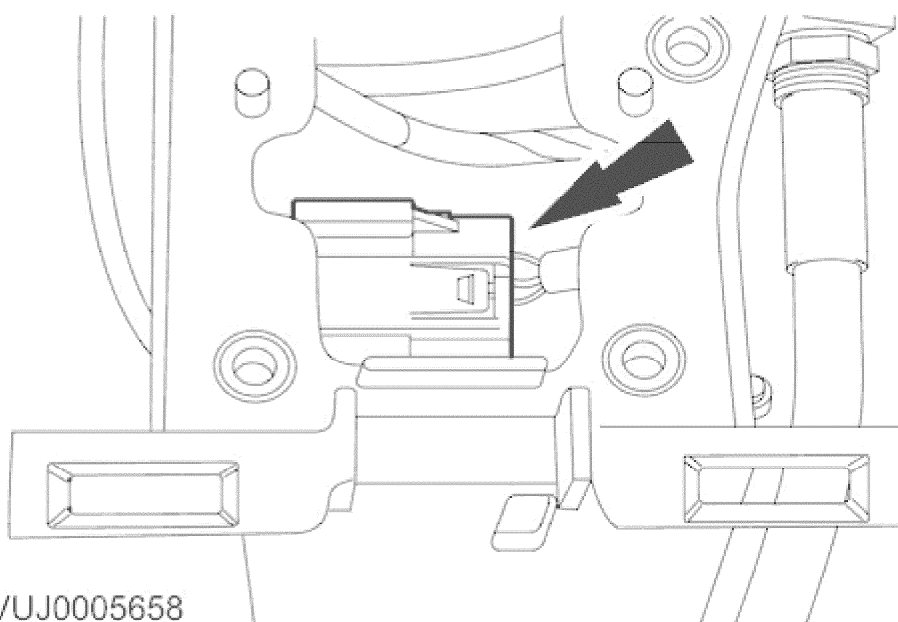

VUJ0005658

3. Connect the electrical connector.

4. Install the parking brake switch. <<206-05>>

5. **NOTE:**

Fully extend the selector cable, then retract the selector cable one detent.

Make sure the selector lever cable is in the 'R' position.

6. Make sure the transmission selector lever is in the 'R' position.

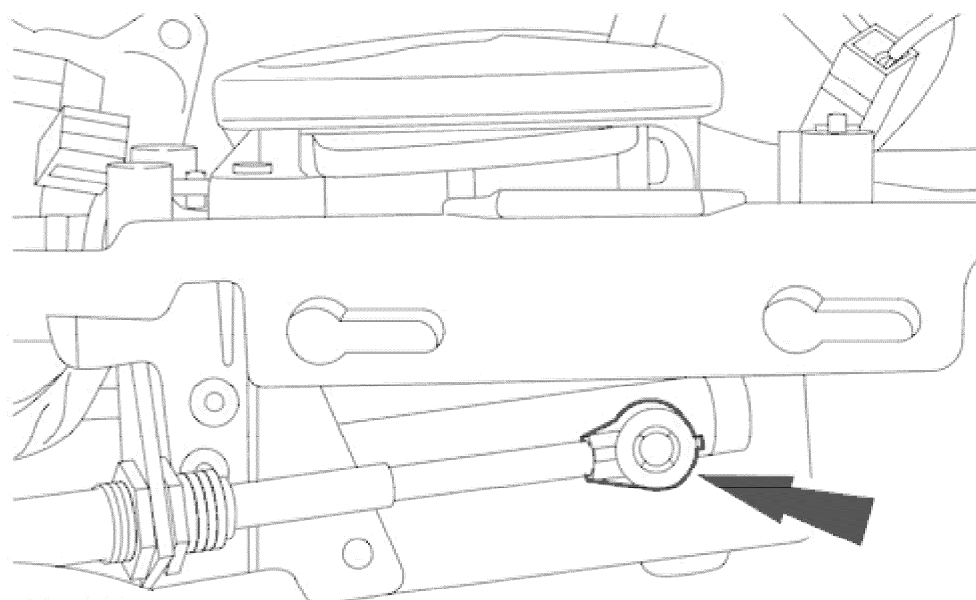

E30355

7. Attach the selector lever cable.

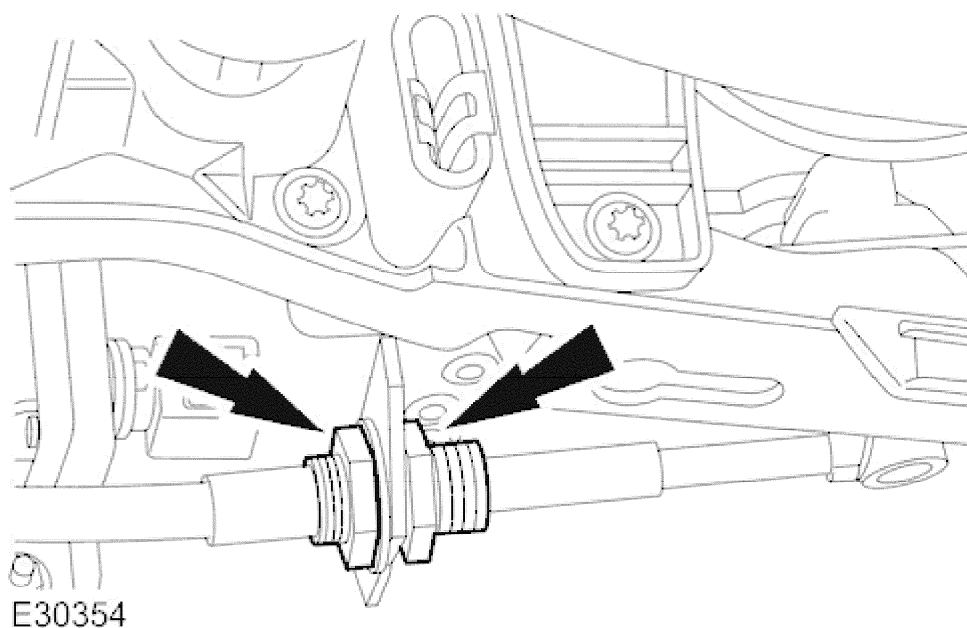

8. Loosen the selector lever cable lock nuts.

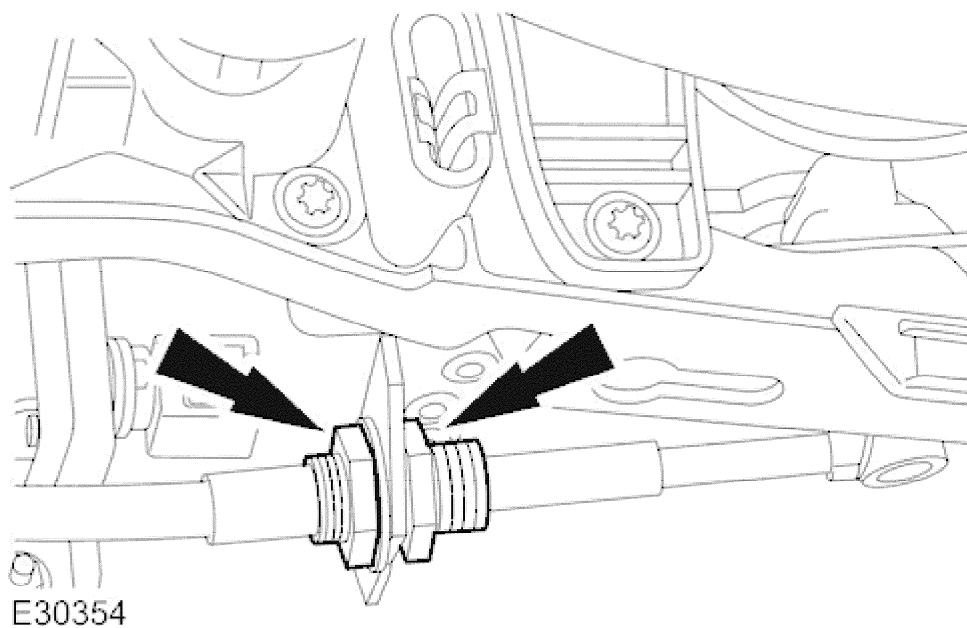

9. Adjust the selector lever cable lock nuts to lock against the retaining bracket without moving the set position of either the shift lever or the selector lever cable.

- Do not fully tighten the selector lever cable lock nuts.

10. **NOTE:**

Make sure all transmission selector lever positions select the relevant automatic transmission states.

Move the transmission selector lever to all positions.

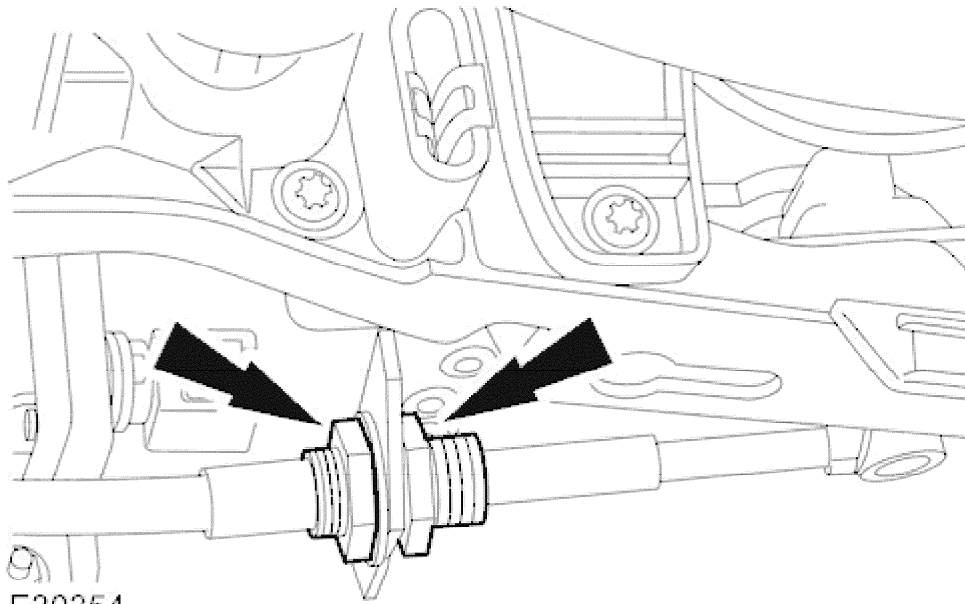

E30354

11. **NOTE:**

When tightening the selector lever cable lock nuts, make sure both lock nuts are tightened to the specified torque simultaneously.

Tighten the selector lever cable lock nuts.

- Tighten to 20 Nm.