

Valve Cover: Service and Repair

RH

Valve Cover RH
Removal
All vehicles

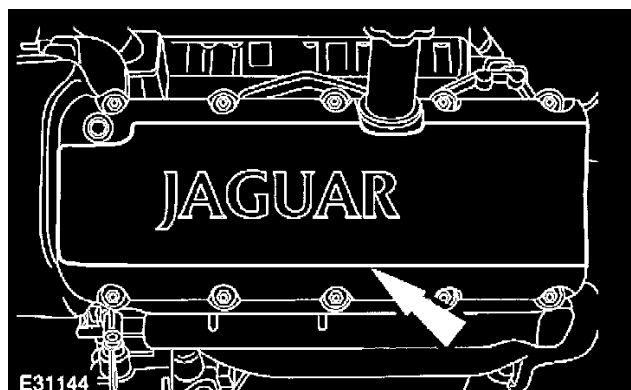

1. **NOTE:** Left-hand shown right-hand similar.

Remove the ignition coil-on-plug cover.

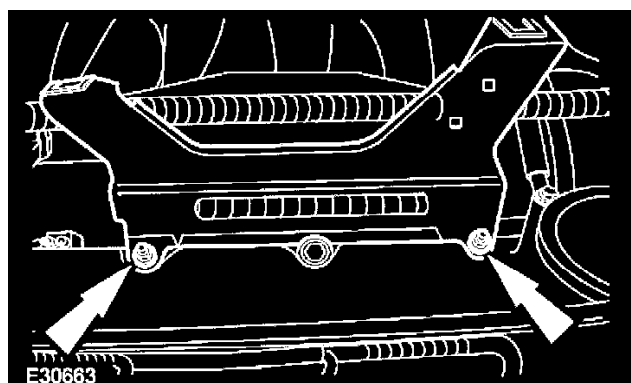

Vehicles without supercharger

2. Remove the right-hand engine cover bracket.

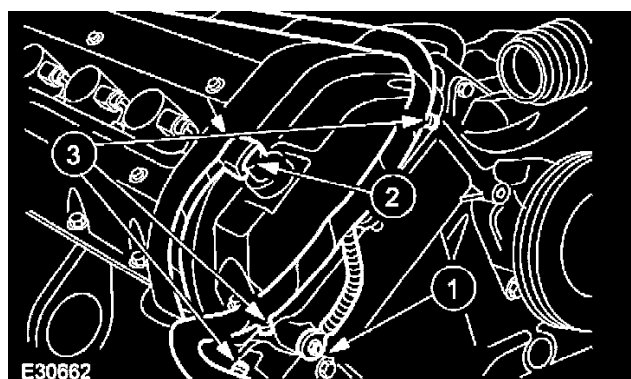

3. Detach the engine wiring harness.
 1. Detach the ground harness
 2. Disconnect the Variable Camshaft Timing (VCT) oil control solenoid electrical connector.
 3. Detach the engine wiring harness.

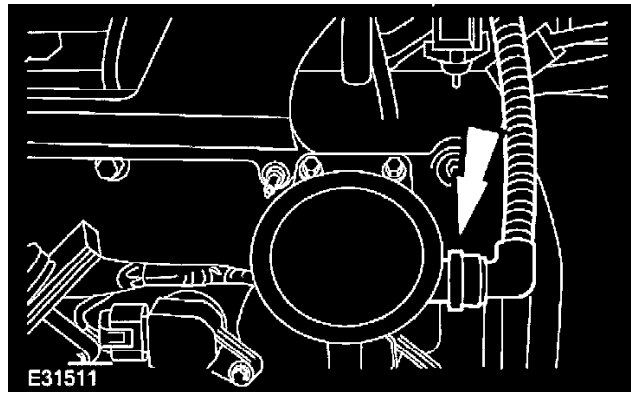
**All vehicles**

4. Disconnect the Positive Crank Ventilation (PCV) pipe.

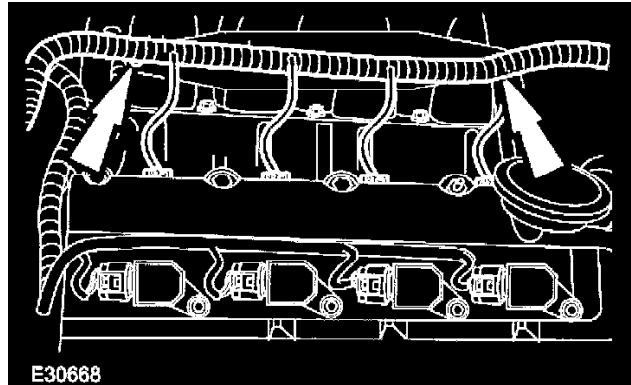

5. Detach the right-hand engine wiring harness.

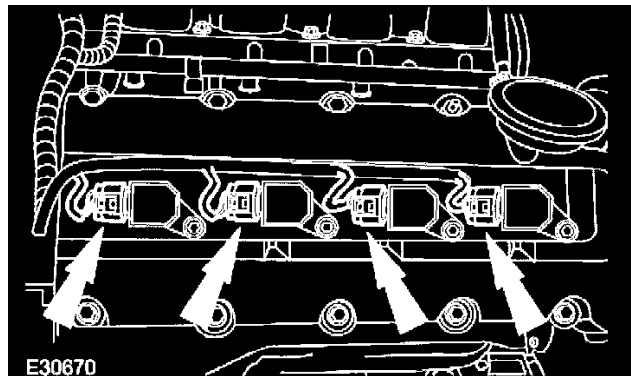

6. Remove the ignition coil-on-plugs.
^ Remove the retaining bolts.

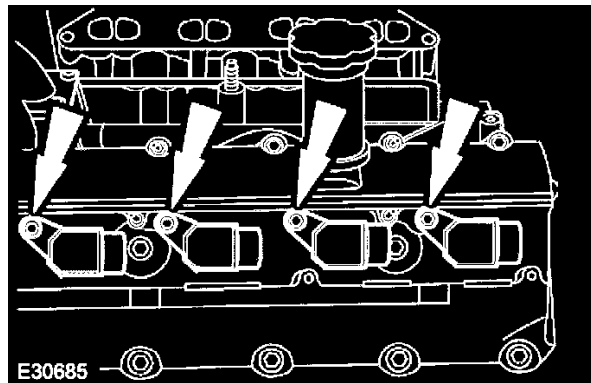

7. Remove the ignition coil-on-plugs.
^ Remove the retaining bolts.

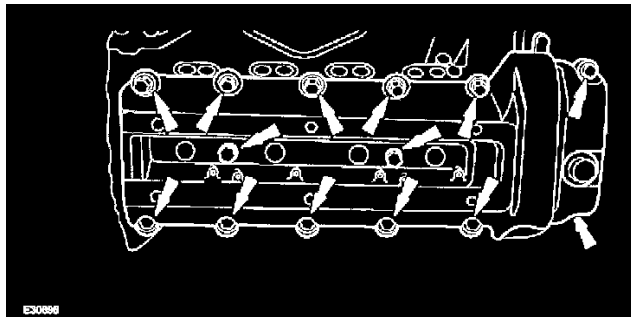

8. Remove the valve cover assembly.

- ^ Remove and discard valve cover gaskets.

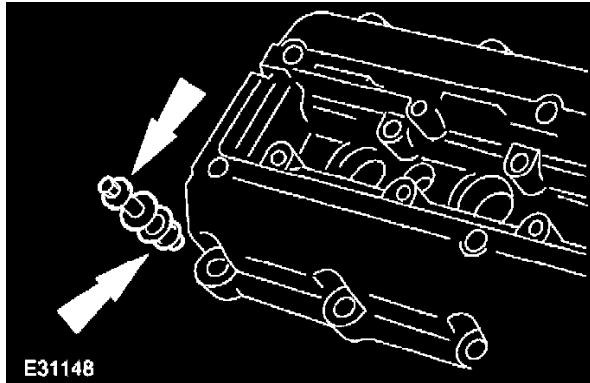

9. **NOTE:** On removal of the valve cover retaining bolts note their positions in the valve cover.

Remove the valve cover retaining bolts.

- ^ Remove and discard the valve cover retaining bolt O-ring seals.

Installation

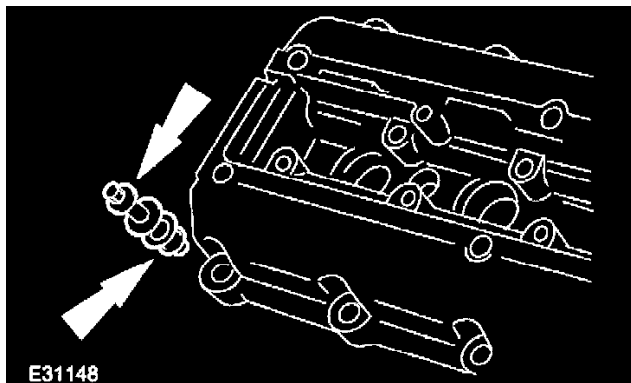

All vehicles

1. **NOTE:** Install the valve cover retaining bolts to their positions previously noted.

Install the valve cover retaining bolts.

- ^ Install new valve cover retaining bolt O-ring seals.

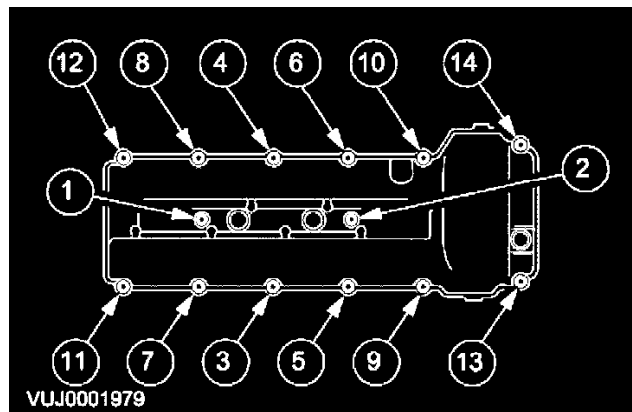

2. Install the valve cover.

- ^ Install new valve cover gaskets.
- ^ Complete the tightening sequence.
- ^ Tighten to **12 Nm**.

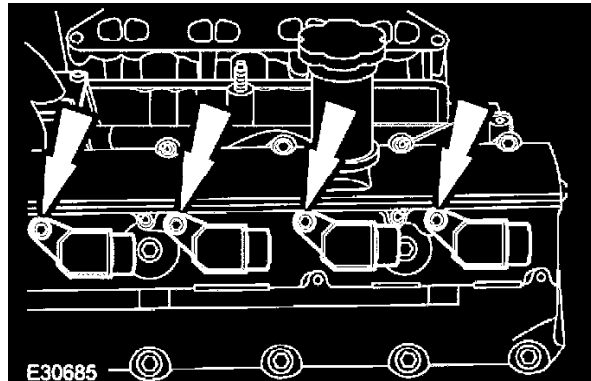

3. Install the ignition coil-on-plugs.

- ^ Tighten to **5 Nm**.

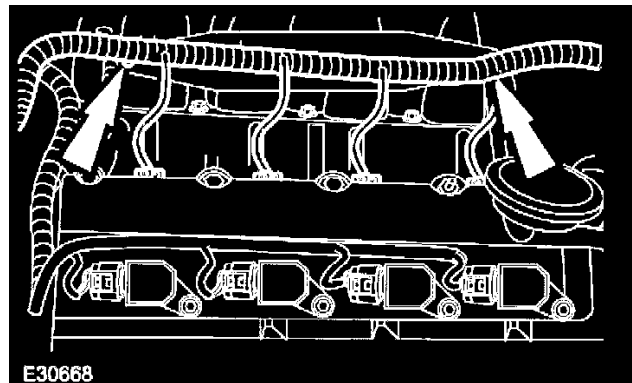

4. Attach the right-hand engine wiring harness.

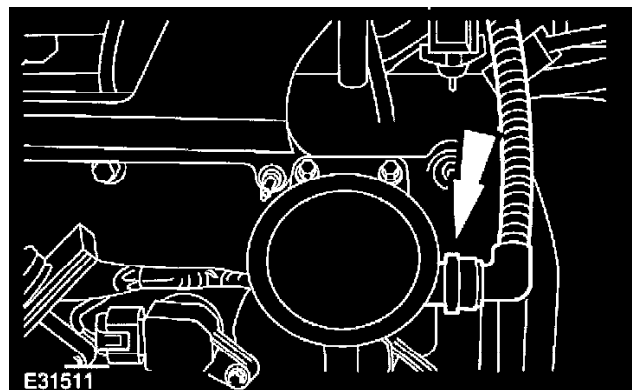

5. Connect the Positive Crank Ventilation (PCV) pipe.

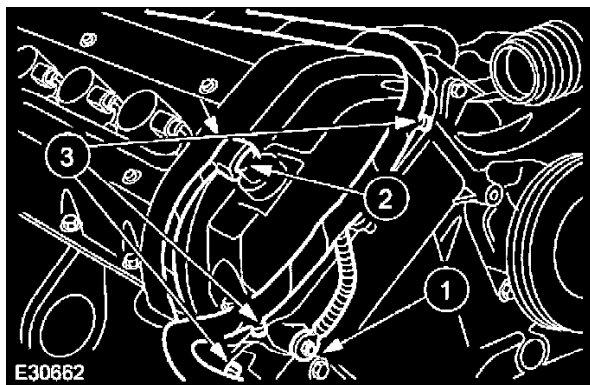

Vehicles without supercharger

6. Attach the engine wiring harness.
 1. Attach the ground harness
 2. Connect the VCT oil control solenoid electrical connector.
 3. Attach the engine wiring harness.

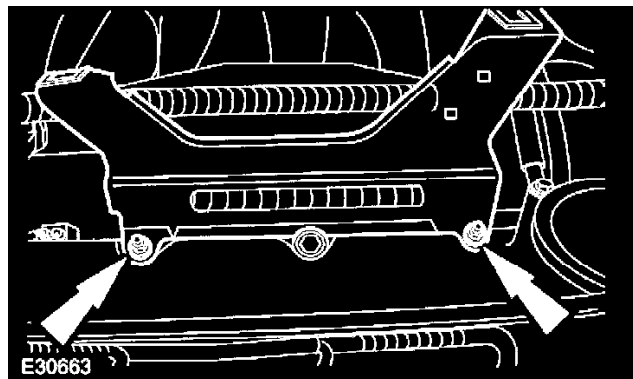

7. Install the right-hand engine cover bracket.

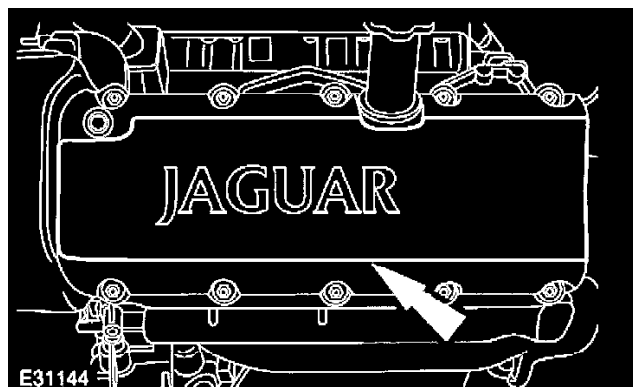

All vehicles

8. **NOTE:** Left-hand shown right-hand similar.

Install the ignition coil-on-plug cover.