

LUBRICATION SYSTEM

Oil Level / Temperature Sensor

The AJ133 5.0L engines use a new ultrasonic oil level/temperature sensor, a first for Jaguar. The new sensor provides an electronic indication when the oil in the engine sump is low or high. This allows for the elimination of the mechanical dipstick.

The sensor maps the oil fill level continuously during trips. The advantage over the static dipstick method is that all 'marginal influences' are compensated for by

averaging. Marginal influences include the vehicle being on a slope, the oil flowing back at the end of a journey, lateral and longitudinal acceleration, or even dipstick tolerances.

The values determined can be used to signal that the minimum oil level has been reached or to display the current oil level if required.

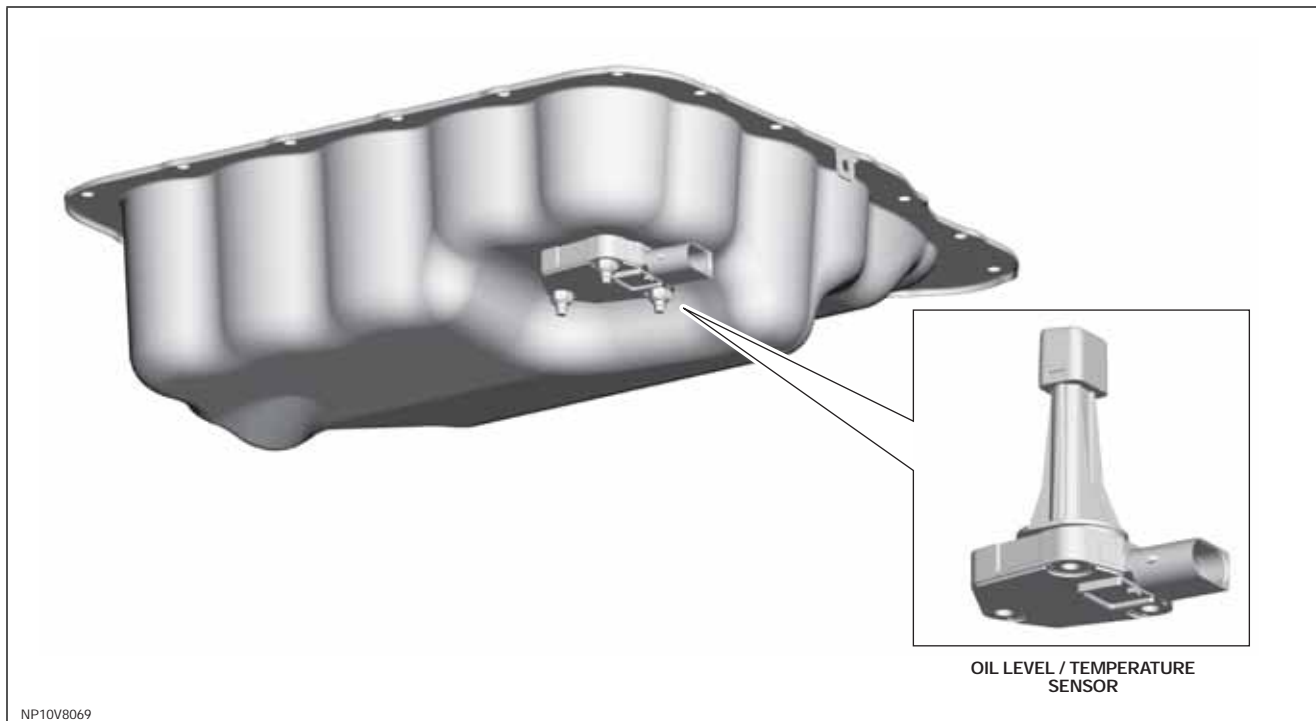

The continuous-mode sensor measures engine oil level and temperature. The oil level and oil temperature readings are converted into a pulse-width modulated (PWM) output signal.

The measuring system consists of a flange, connector, electronic circuitry, and the sensor itself. Oil level metering is determined by the oil-to-air interface layer.

The oil level sensor has the following technical properties:

- Linear measuring range
- Continuous measuring under static and dynamic conditions
- Temperature signal and oil level signal 0.3s after switch-on
- Measuring frequency > 10 Hz
- Customer-specific output signal
- Installs at bottom of oil sump
- Temperature measuring

The sensor is mounted to the underside of the sump, from where it sends an ultrasonic pulse vertically upward (engine position). It then measures the time for the pulse to be reflected back from the top surface of the oil.

It compares this time period with a time period of a second pulse which travels within the sensor across a reference distance. With both time periods it can calculate the oil height from the sensor flange, negating the noise factors which affect the speed of the pulse through the oil.

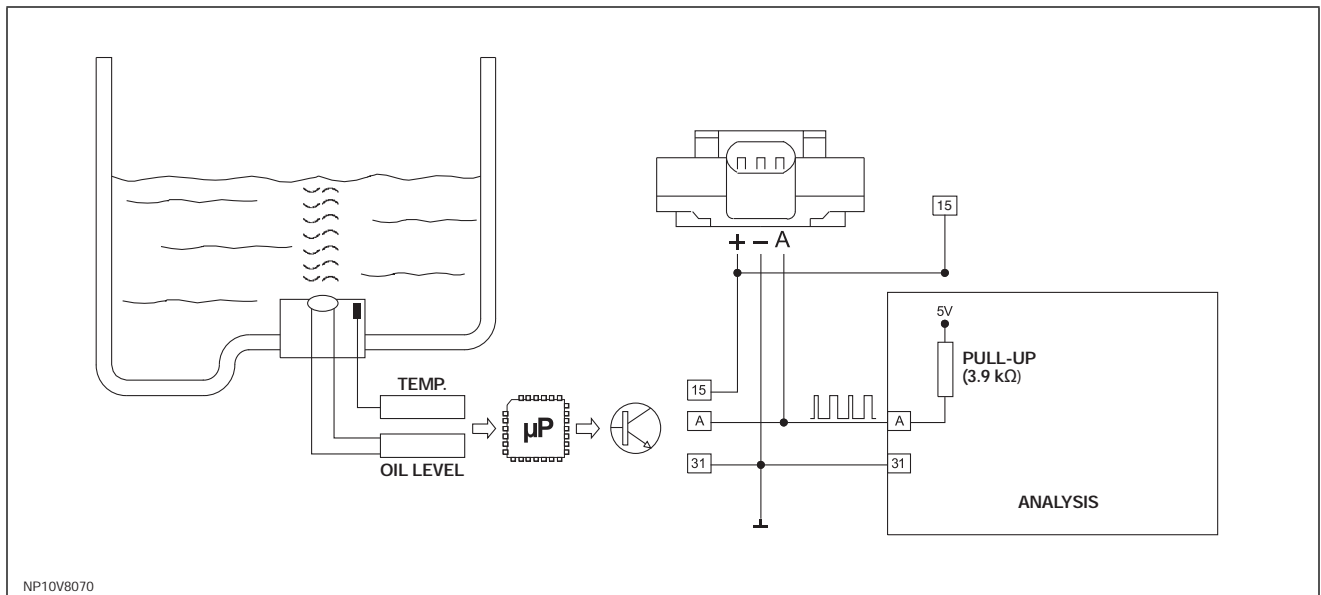

NP10V8070

Specification	Function
Power source	Battery voltage
Level Accuracy	±2mm (±4mm < -30°C)
Temperature Accuracy	±2°C (35°F)
Operating Level Range	18mm – 116mm (Dynamic) 116mm – 147mm (Static)
Operating Temp. Range	-40°C – 160°C (-40°F – 320°F)
Pin 1	Power Supply
Pin 2	Ground
Pin 3	Output Signal

Oil Pressures

Engine Speed	Temperature	Pressure
Idle	20°C (68°F)	2 bar (29 psi)
1500 rpm	20°C (68°F)	6 bar (87 psi)
3000 rpm	40°C (104°F)	6.2 bar (90 psi)
3000 rpm	110°C (230°F)	5 bar (72.5 psi)
3000 rpm	130°C (266°F)	4 bar (58 psi)

Oil Evacuation Tube

The Jaguar 5.0L engine sees the introduction of an oil evacuation tube in addition to the traditional oil drain plug. The oil evacuation tube is installed to allow oil to be drawn from the sump pan for servicing using a Jaguar-approved oil evacuation tool. The upper end of the oil evacuation tube is located under the oil filler cap. For detailed Oil Vacuum Draining and Filling procedures, please refer to the appropriate section of the workshop manual.

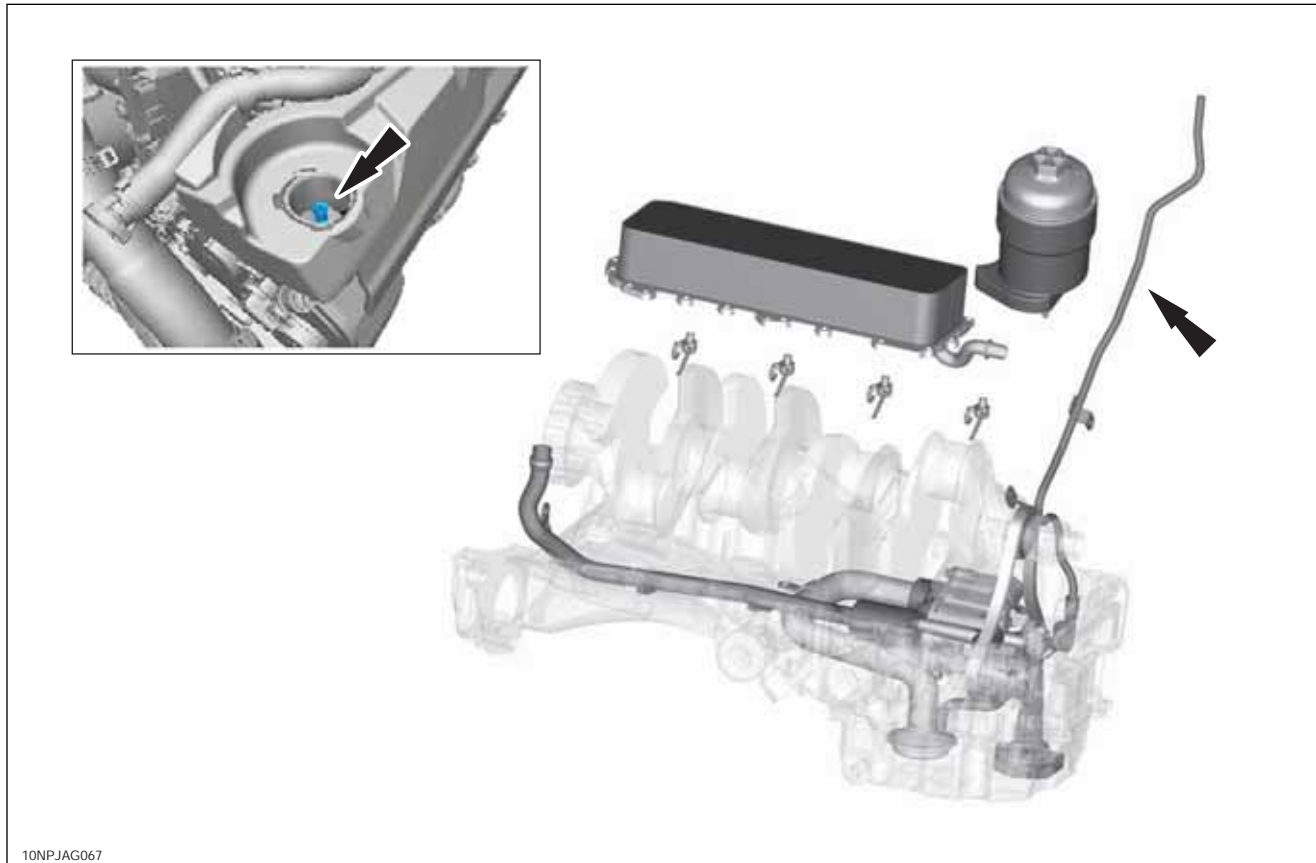

Oil Level Check / Service Mode (5.0L)

In its normal mode, the oil level display uses an 'average oil level', derived from an algorithm that calculates and monitors the engine oil level over a period of time, thus producing an averaged oil level. 'Service Mode' is an accurate live reading of the oil level and is not a time-averaged value. Service Mode is for use by technicians during the PDI procedure and after an oil change.

In order to access Service Mode and generate an accurate live reading, the following conditions must be met:

- The vehicle **MUST** be parked on level ground. The sensor installation is very sensitive to vehicle tilt in the fore-aft direction: 0.5° vehicle tilt can generate an oil level measurement error up to 0.5 liter (0.52 qt.).
- The gear selector must be in the PARK position and the hood must be open.
- A minimum wait of 10 minutes must pass after the engine is switched off. This allows the oil in the system to drain back to the sump. Monitoring the oil level without this wait will give an incorrect reading.

To enter Service Mode:

- Scroll through the trip menu to access the oil level display.
- Press the cruise control CANCEL button twice within 2 seconds.
- The instrument pack display will revert to the normal display in the trip computer.
- Scroll through the trip menu to access the oil level display once more.
- The graphic now corresponds to the LIVE (Service Mode) value.

Key to illustration:

- **A:** Oil level 50% to 100% of recommended level. No top-up required.
- **B:** Oil level 12.5% to 50% of recommended level. Add 0.5 liters of oil.
- **C:** Oil level 0% to 12.5% of recommended level. Add 1 liter of oil.
- **D:** Oil above maximum for safe operation. Do not drive vehicle. Seek qualified assistance.
- **E:** Oil level below minimum for safe operation. Add 1 liter of oil and re-check.
- **F:** Oil drain in progress, oil level not available. Wait 5 minutes then re-check the oil level display.
 - **XF:** The message center will display the message 'NOT AVAIAABLE SEE HANDBOOK' without the oil can icon
 - **XK:** The message center will display the oil can icon with the message 'NOT AVAIAABLE SEE HANDBOOK'

NOTE: If this display is accompanied by the warning message 'ENGINE OIL LEVEL MONITOR SYSTEM FAULT', a fault with the oil level monitor is indicated. Seek qualified assistance.

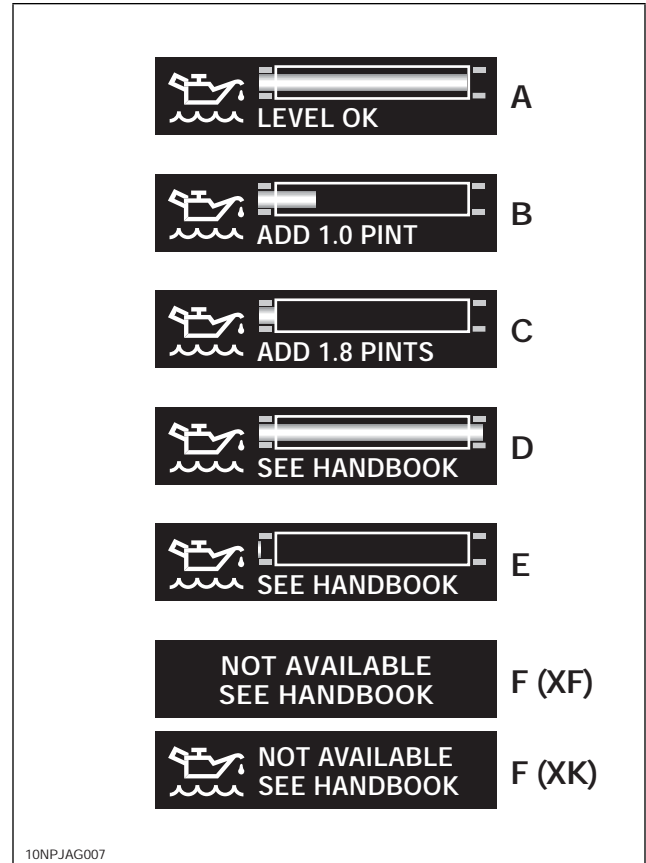
XF/XK Message Center Oil Level Display

Average Oil Level Reset Procedure

The average oil level reset procedure enables the technician to reset the averaged oil level data stored. This is required during PDI and after an oil change.

To reset the stored averaged oil level data:

- Scroll through the trip menu to access the oil level display.
- Press the cruise control CANCEL button twice within 2 seconds.
- The instrument pack display will revert to the normal display in the trip computer.
- Scroll through the trip menu to access the oil level display once more.
- The graphic now corresponds to the LIVE value.
- Press and hold the cruise control CANCEL button for more than 2 seconds.
- Switch the ignition off to allow the ECU to shutdown completely.
- Switch the ignition on, access the oil level display and verify that the stored value has updated correctly.

Service Interval Indicator Reset Procedure

The procedure described below is used to reset the Service Interval Indicator. During the process, switch presses must each be carried out within 3 seconds:

- With the vehicle ignition off, press and hold the rear fog lamp switch
- Allow the vehicle to enter power mode
- Press the start button without the brake pedal depressed
- Immediately release the rear fog lamp switch
- Press and hold the trip computer cycle switch
- Press and hold the rear fog lamp switch
- Continue to hold the trip computer and rear fog lamp switches
- If the process has been successful, the message center will display 'RESETTING SERVICE MODE' and then display 'SERVICE MODE RESET' after 10 – 15 seconds
- Release both switches and switch the ignition off.