

2010.0 XF (X250), 303-04

FUEL CHARGING AND CONTROLS - V8 S/C 5.0L PETROL

HIGH PRESSURE FUEL PUMP 2 (G1185931)

REMOVAL AND INSTALLATION

19.45.30	HIGH PRESSURE FUEL PUMP - FRONT - RENEW	5000 CC, AJ V8, SUPERCHARGED	3.7	USED WITHINS
----------	--	------------------------------------	-----	-----------------

19.45.31	HIGH PRESSURE FUEL PUMP - REAR - RENEW	5000 CC, AJ V8, SUPERCHARGED	3.8	USED WITHINS
----------	---	------------------------------------	-----	-----------------

REMOVAL

WARNING:

Do not smoke or carry lighted tobacco or open flame of any type when working on or near any fuel related components. Highly flammable mixtures are always present and may ignite. Failure to follow these instructions may result in personal injury.

CAUTION:

Make sure that tools and equipment are clean, free of foreign material and lubricant.

 **NOTE:**

Some variation in the illustrations may occur, but the essential information is always correct.

1. Refer to: [Petrol and Petrol-Ethanol Fuel Systems Health and Safety Precautions](#) (100-00 General Information, Description and Operation).
2. Refer to: [Fuel System Pressure Release - V8 5.0L Petrol/V8 S/C 5.0L Petrol](#) (310-00 Fuel System - General Information, General Procedures).
3. Refer to: [Secondary Bulkhead Panel LH - TDV6 3.0L Diesel /V8 5.0L Petrol/V8 S/C 5.0L Petrol](#) (501-02 Front End Body Panels, Removal and Installation).
4. Refer to: [Secondary Bulkhead Panel RH - TDV6 3.0L Diesel /V8 5.0L Petrol/V8 S/C 5.0L Petrol](#) (501-02 Front End Body Panels, Removal and Installation).
5. Refer to: [Engine Cover - V8 5.0L Petrol/V8 S/C 5.0L Petrol](#) (501-05 Interior Trim and Ornamentation, Removal and Installation).
6. Refer to: [Fuel Injection Component Cleaning](#) (303-04C Fuel Charging and Controls - V8 5.0L Petrol, General Procedures).
- 7.

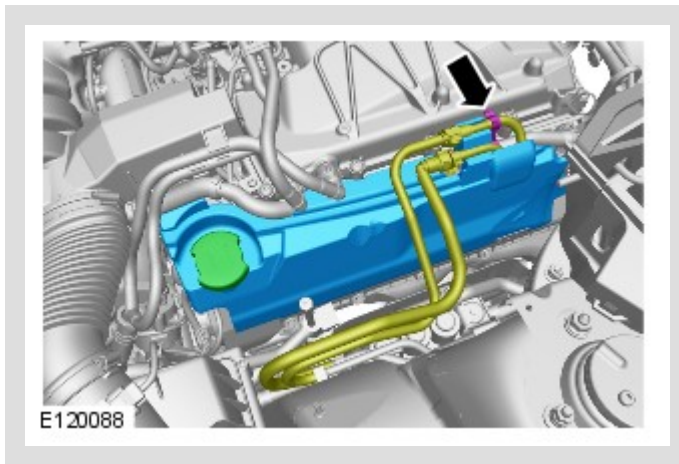

8.

ⓘ CAUTION:

Be prepared to collect escaping fluids.

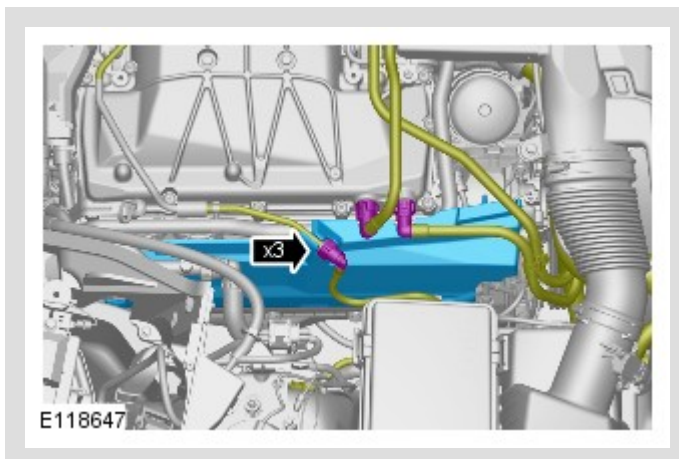

9.

Refer to: [Air Cleaner Outlet Pipe RH \(303-12C Intake Air Distribution and Filtering - V8 5.0L Petrol, Removal and Installation\)](#).

10.

ⓘ CAUTIONS:

- Be prepared to collect escaping fluids.
- Make sure that all openings are sealed. Use new blanking caps.

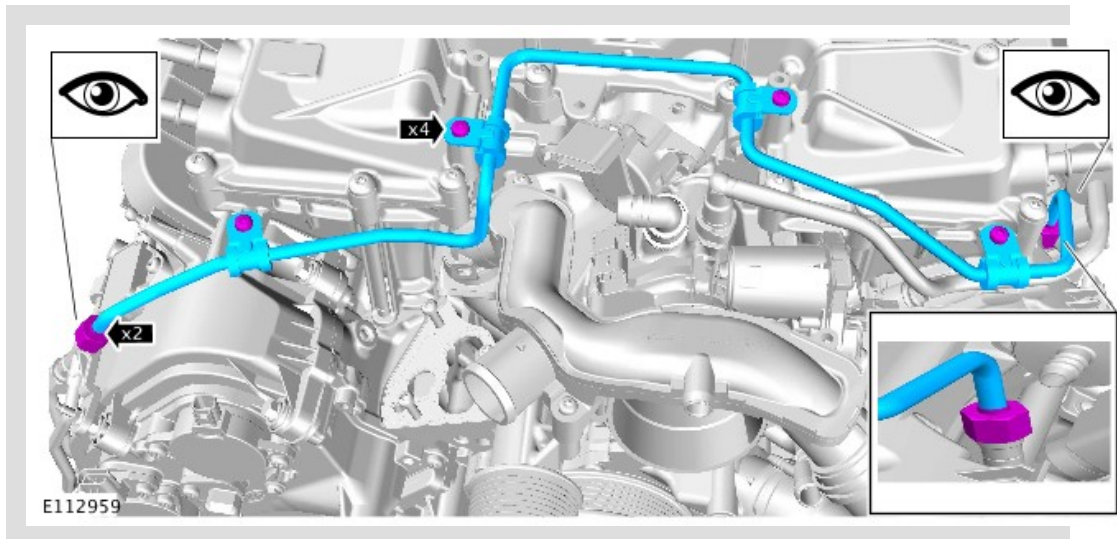

11.

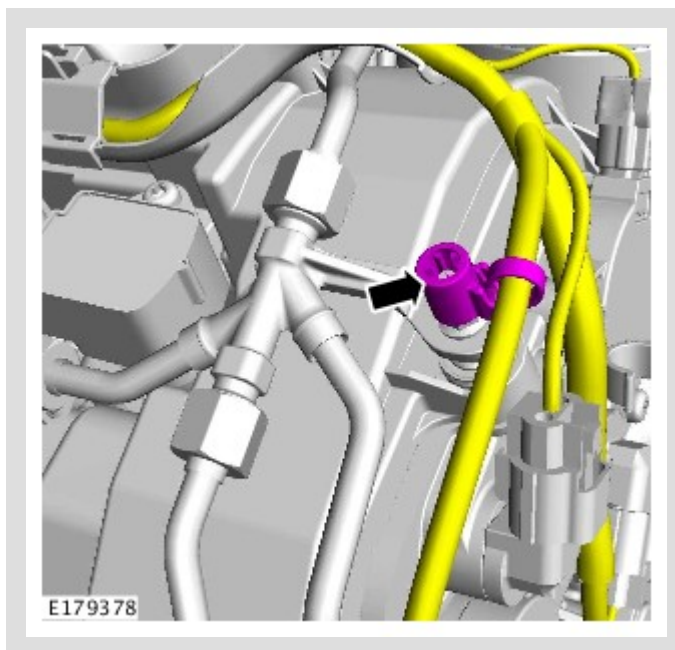

12.

ⓘ CAUTIONS:

- Be prepared to collect escaping fluids.
- Make sure that all openings are sealed. Use new blanking caps.

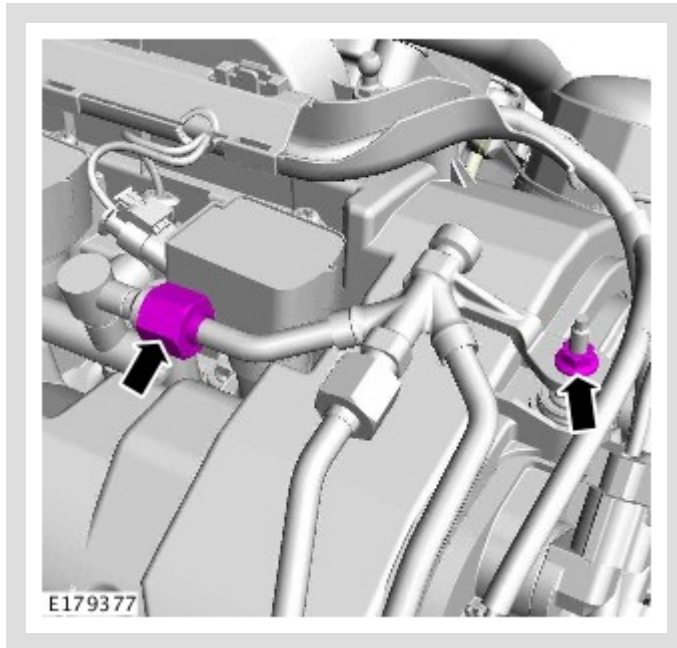

13.

⚠ WARNING:

Do not work on or under a vehicle supported only by a jack. Always support the vehicle on safety stands.

Raise and support the vehicle.

14.

Refer to: [Engine Mount RH](#) (303-01C Engine - V8 5.0L Petrol, Removal and Installation).

15.

Refer to: [Generator - V8 5.0L Petrol](#) (414-02B Generator and Regulator - V8 5.0L Petrol/V8 S/C 5.0L Petrol, Removal and Installation).

16.

📄 NOTE:

Engine shown removed for clarity.

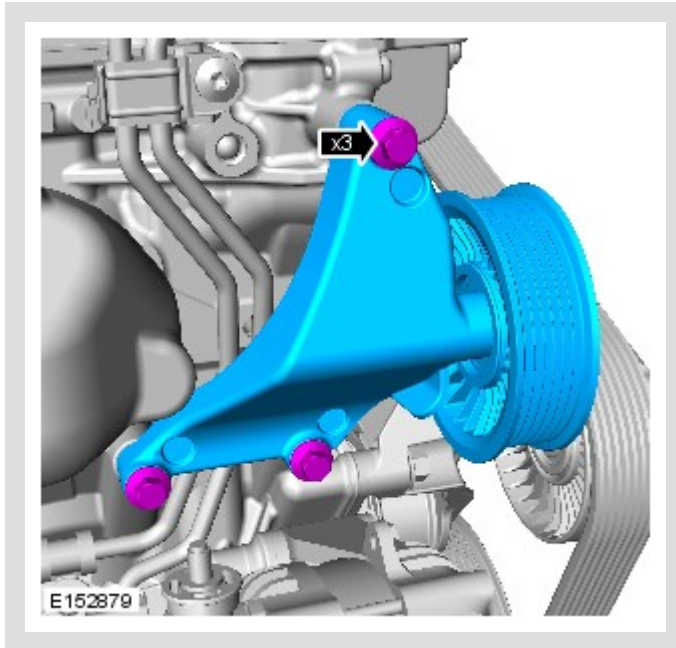

17.

△ NOTE:

Engine shown removed for clarity.

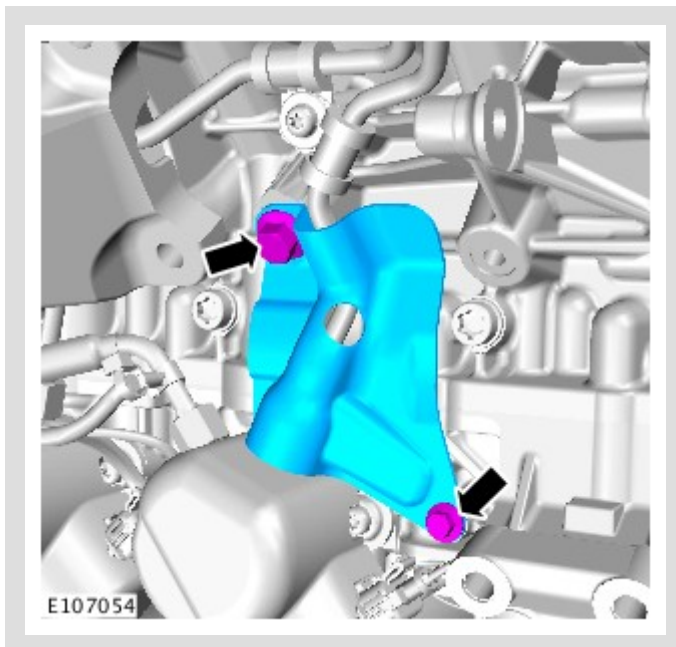

18.

△ NOTE:

Engine shown removed for clarity.

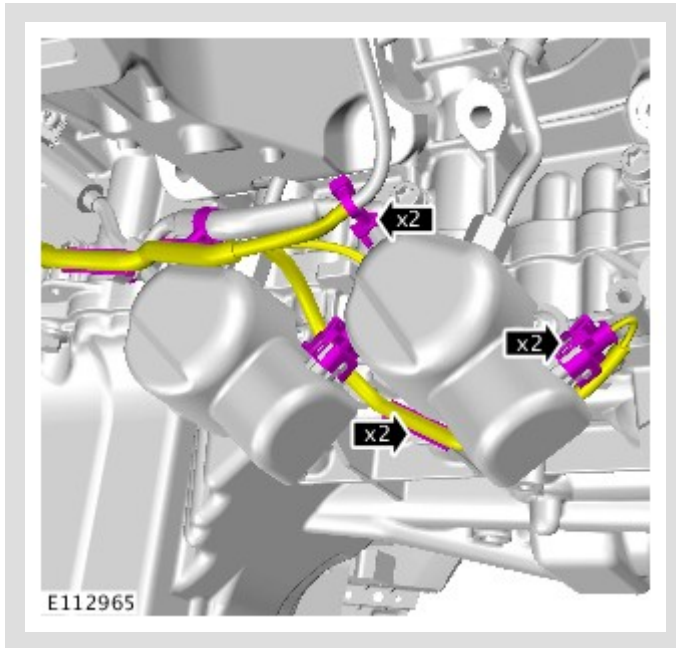

19.

ⓘ CAUTION:

Make sure that all openings are sealed. Use new blanking caps.

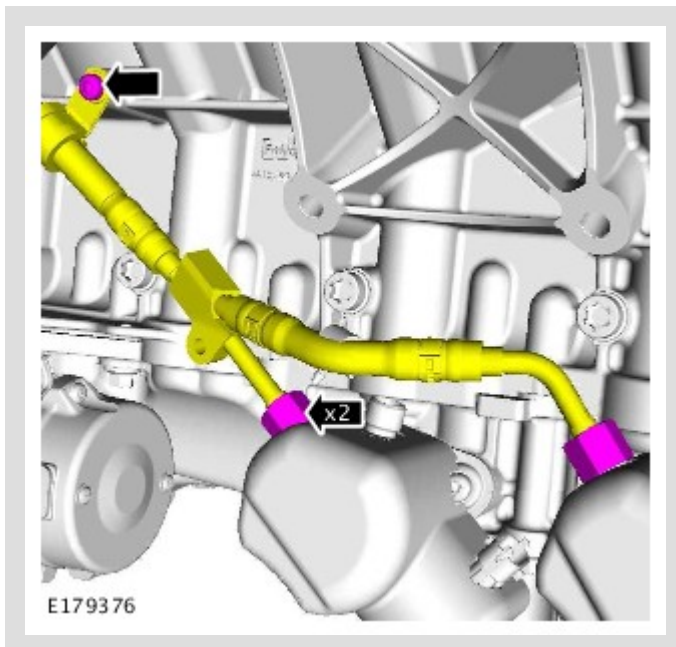

20.

⚠ CAUTIONS:

- Remove and discard the high-pressure fuel supply lines.
- Be prepared to collect escaping fluids.
- Make sure that all openings are sealed. Use new blanking caps.

△ NOTE:

Engine shown removed for clarity.

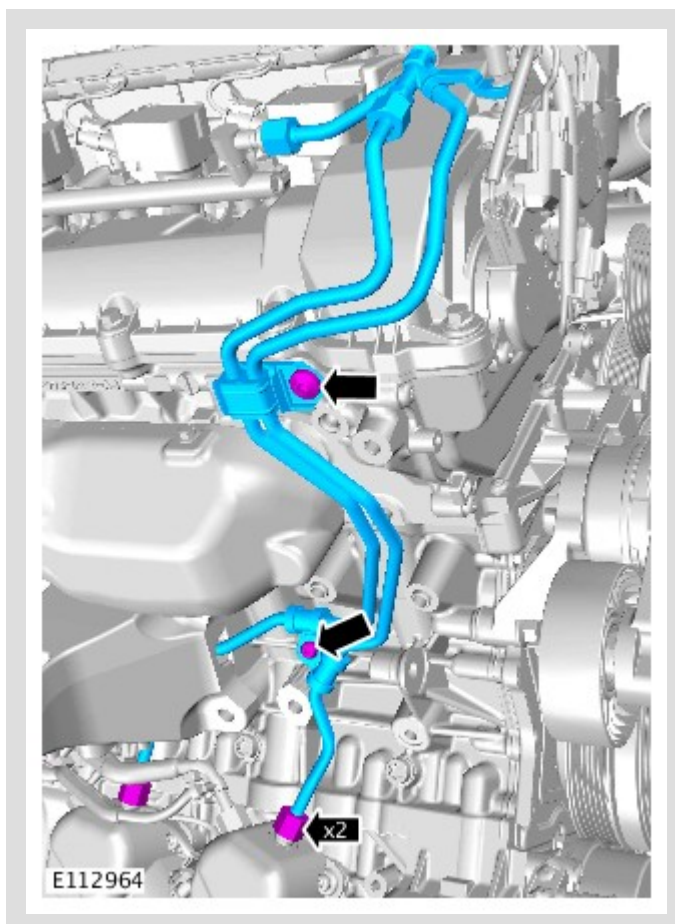

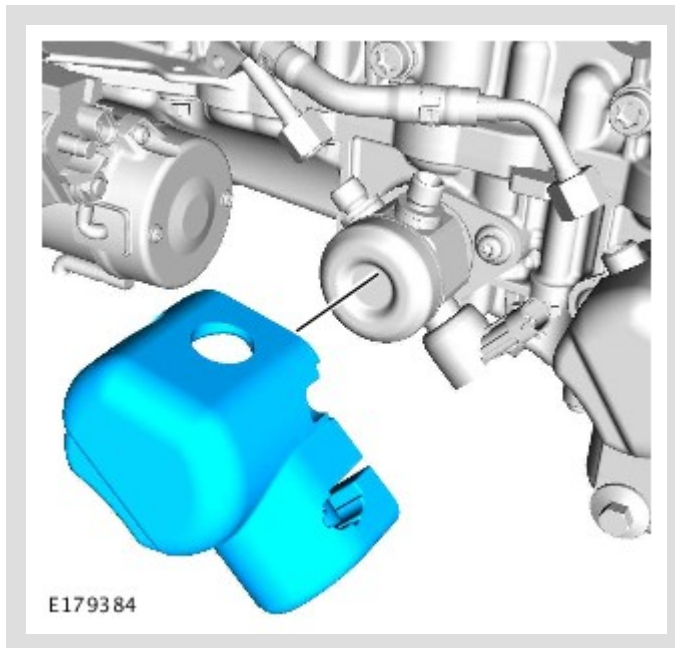

22.

⚠ CAUTION:

Be prepared to collect escaping fluids.

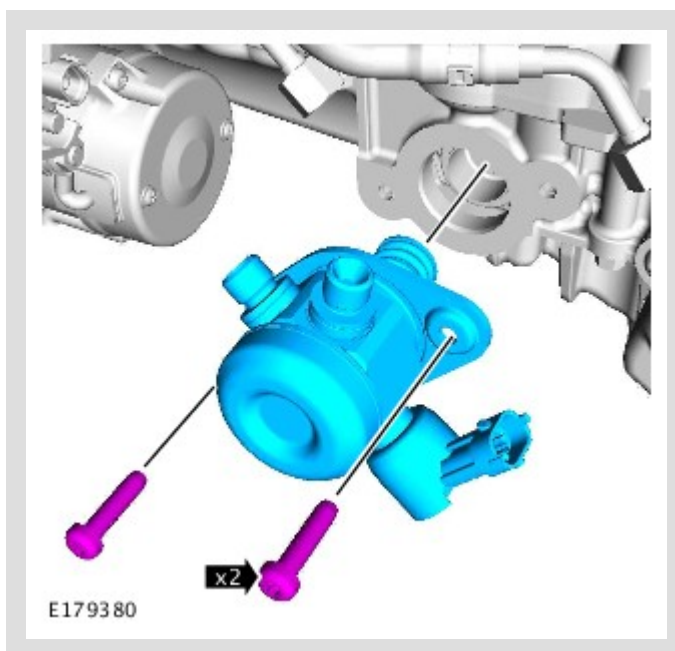

Loosen the Torx screws a turn each at a time.

23.

⚠ CAUTION:

Be prepared to collect escaping fluids.

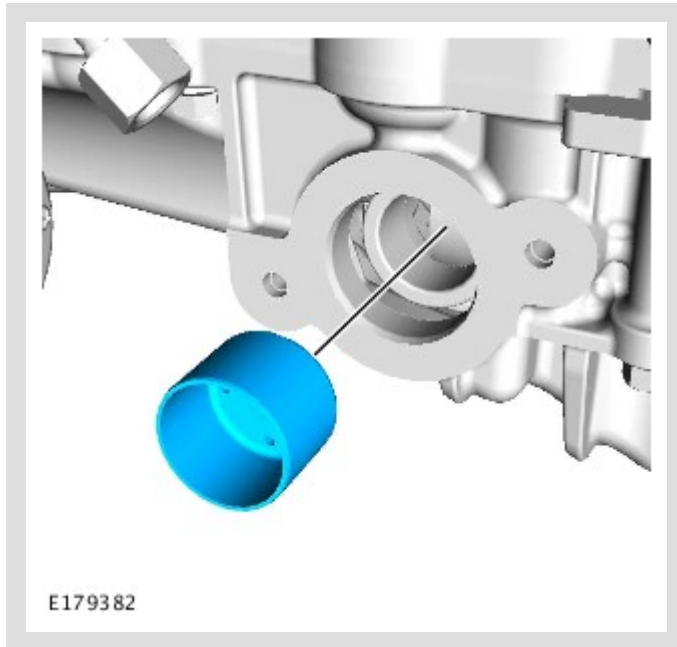

INSTALLATION

1.

⚠ NOTE:

Lubricate the fuel rail high-pressure fuel pump bucket with clean engine oil.

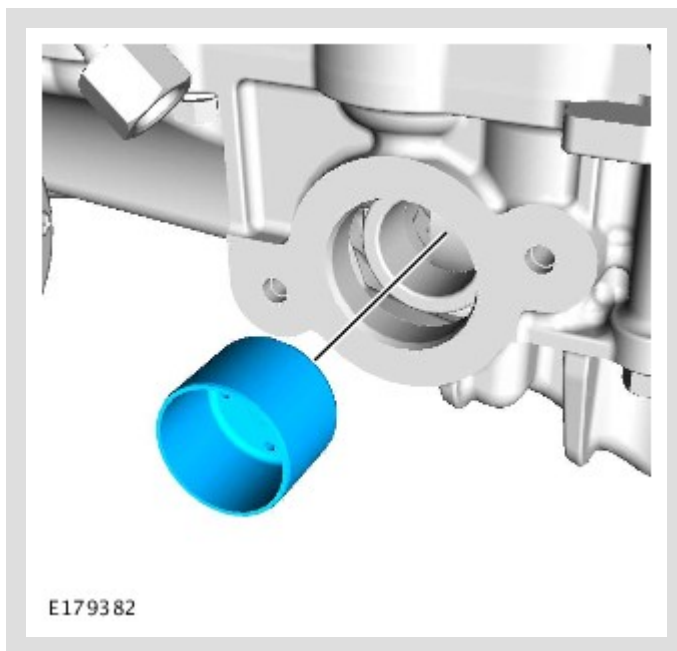

2.

⚠ CAUTION:

Tighten the Torx screws a turn at a time until the correct torque is achieved.

⚠ NOTE:

Lubricate the fuel rail high-pressure fuel pump O-ring seal with clean engine oil.

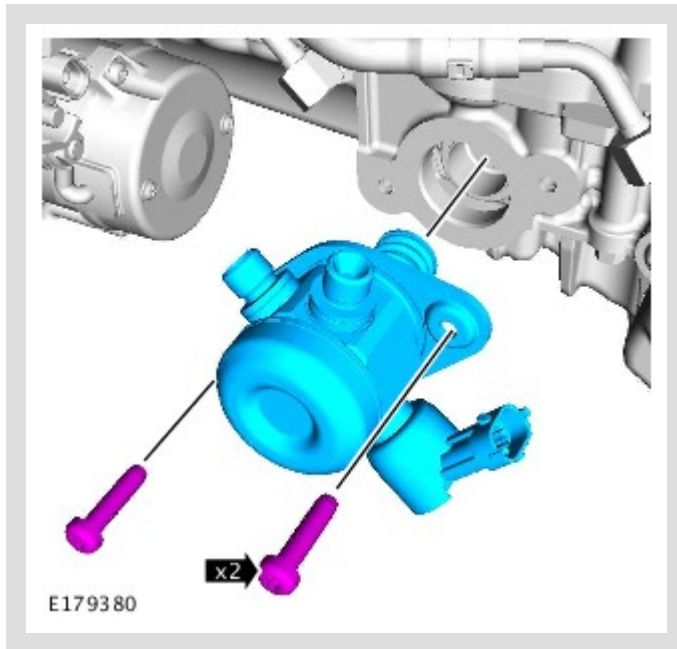

Install the high-pressure fuel pump.

Torque: 12 Nm

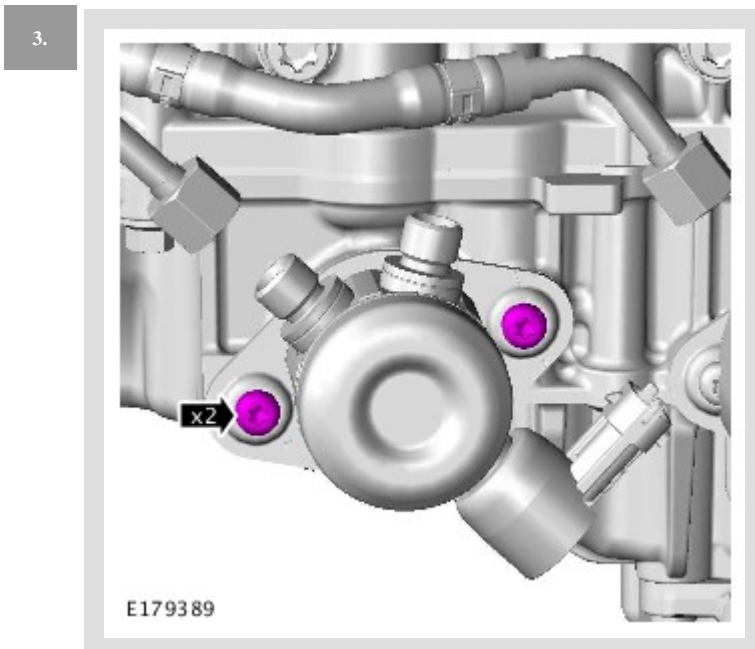

Loosen the Torx screws half a turn each.

4.

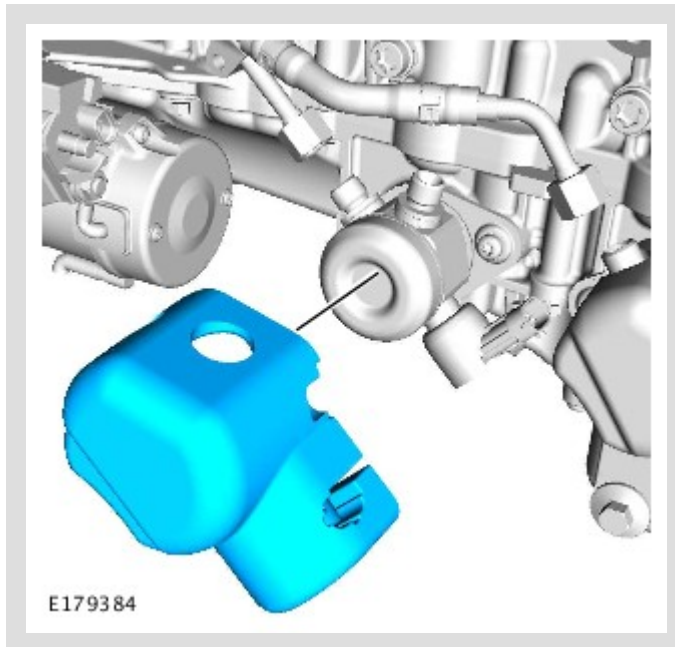

5.

⚠ CAUTIONS:

- Install new high-pressure fuel supply lines.
- Lubricate the high-pressure fuel supply line unions with clean engine oil.

△ NOTES:

- Engine shown removed for clarity.
- Remove and discard the blanking caps.

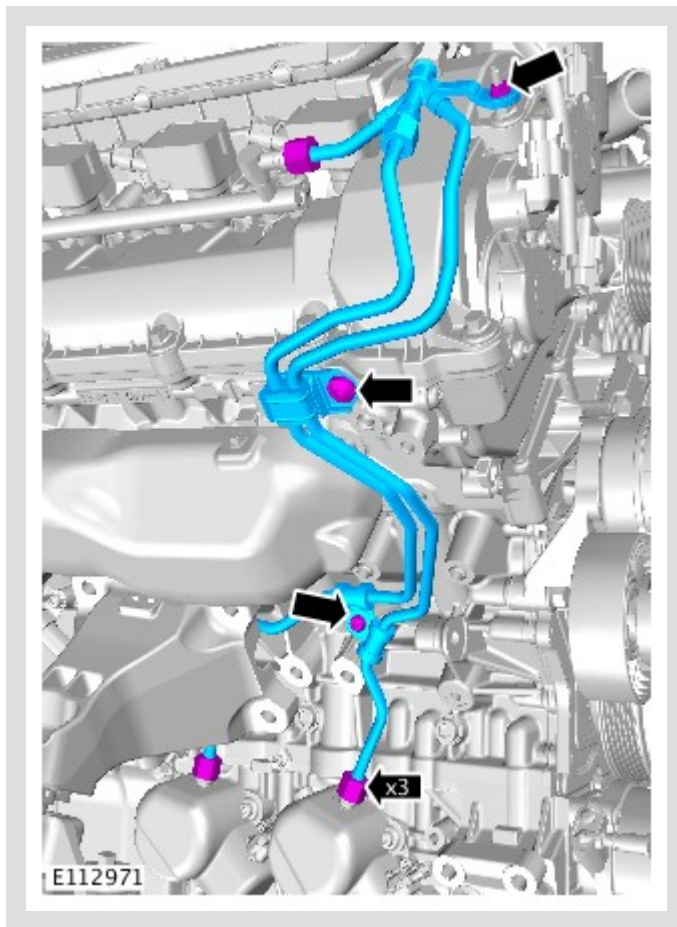

Install the high-pressure fuel supply lines, tighten the bolts and unions finger tight at stage.

6.

⚠ CAUTION:

Care must be taken when positioning the fuel rail high-pressure fuel pump cover to one side.

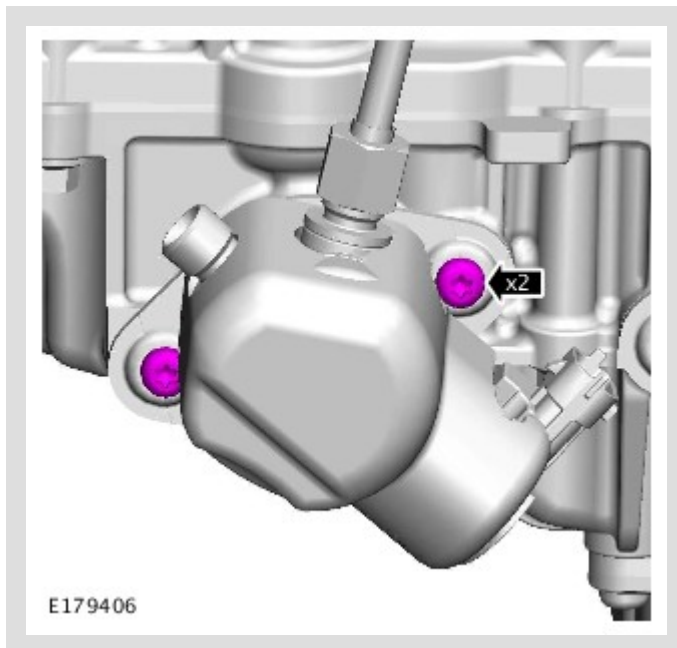

Tighten the Torx screws.

Torque: 12 Nm

7. Lower the vehicle.

8.  **CAUTION:**

Lubricate **only** the union threads with clean engine oil.

 **NOTE:**

Engine shown removed for clarity.

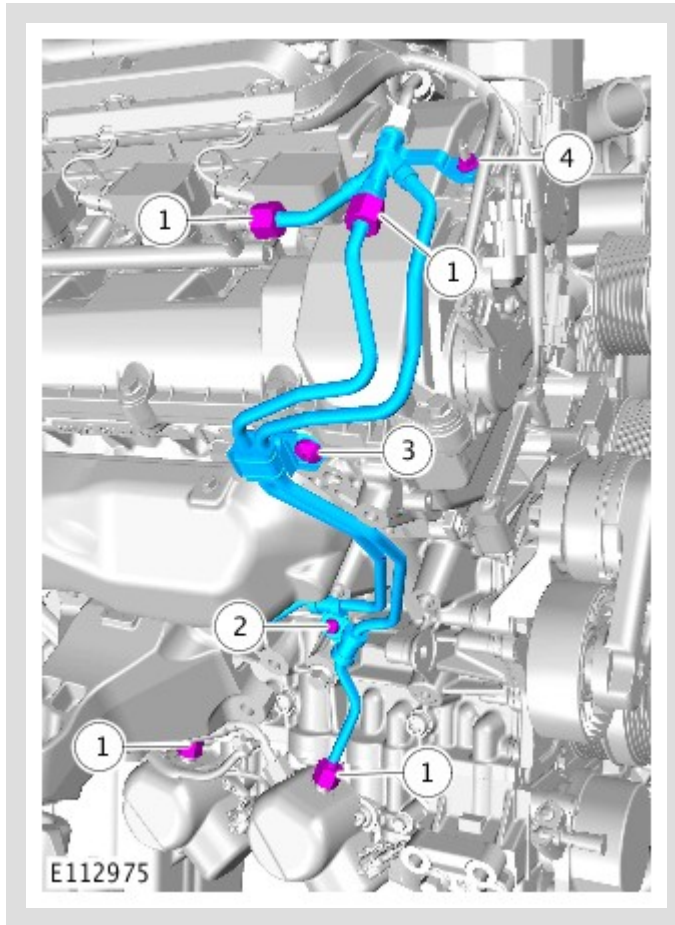

Torque:

Unions (1) **21 Nm**

M6 (2) **11 Nm**

M8 (3) **25 Nm**

M5 nut (4) **6 Nm**

9.

NOTE:

Remove and discard the blanking caps.

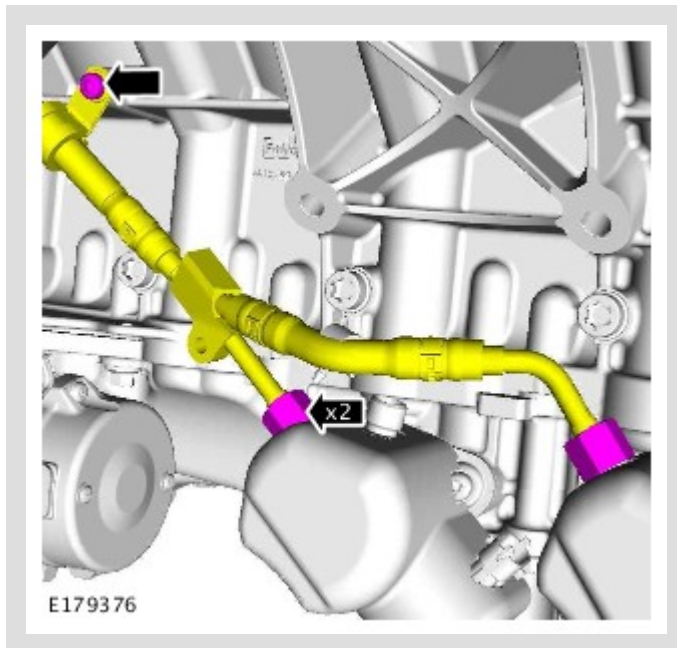

Torque:

Unions **21 Nm**

Bolt **12 Nm**

10.

 **NOTE:**

Install the bolt and unions finger tight before final tightening.

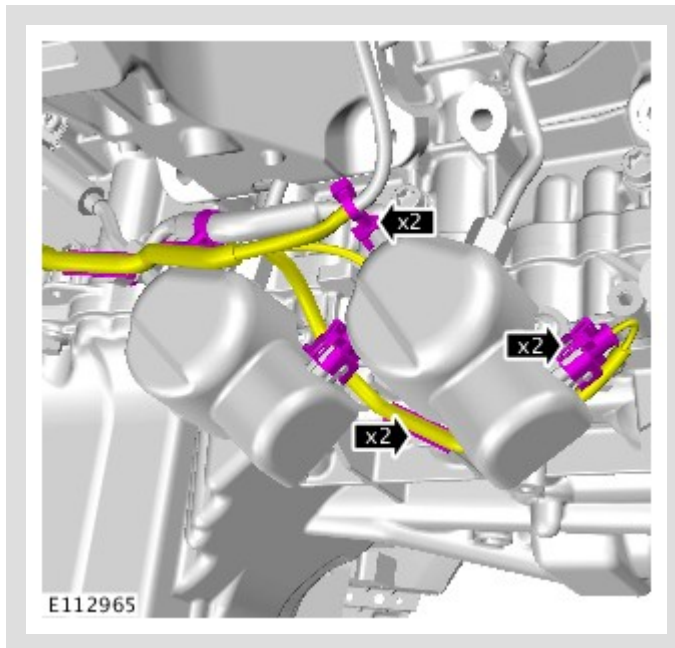

Torque:

Unions **21 Nm**

M6 **11 Nm**

11.

 **NOTE:**

Engine shown removed for clarity.

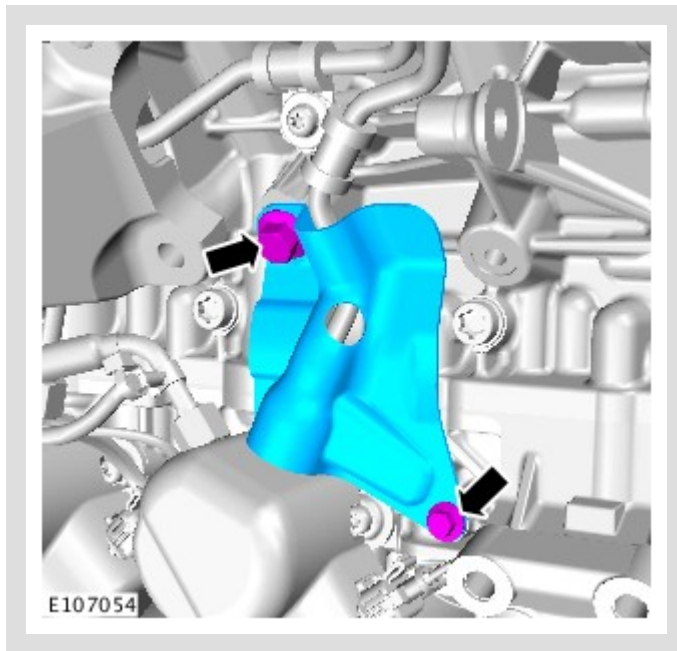

Torque:

M10 **29 Nm**

M6 **11 Nm**

12.

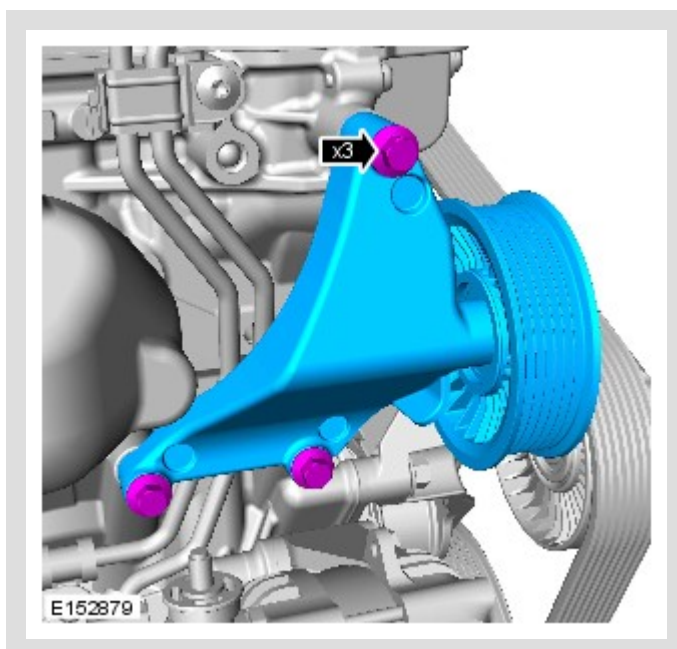

Torque: 25 Nm

13. Refer to: [Generator - V8 5.0L Petrol](#) (414-02B Generator and Regulator - V8 5.0L Petrol/V8 S/C 5.0L Petrol, Removal and Installation).

14. Refer to: [Engine Mount RH](#) (303-01A Engine - V8 4.2L Petrol, In-vehicle Repair).

15.

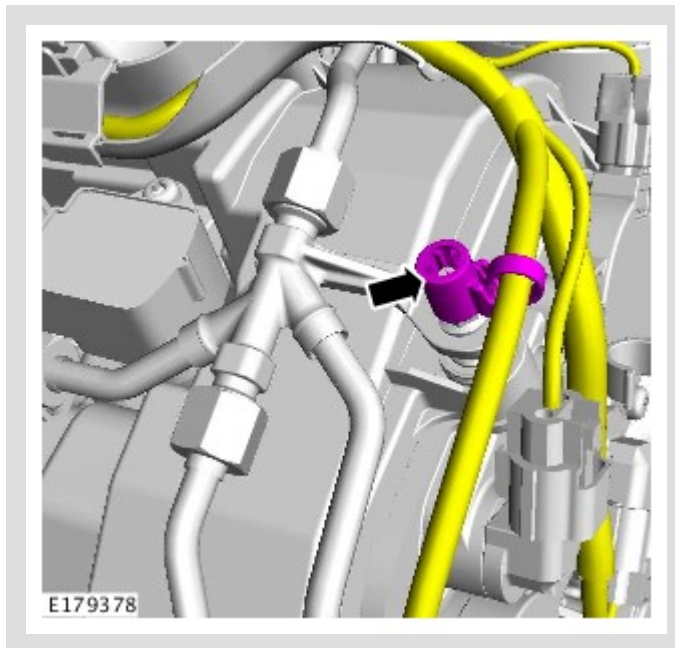

16.



NOTES:

- Lubricate the union threads with clean engine oil.
- Do not tighten at this stage.
- Remove and discard the blanking caps.

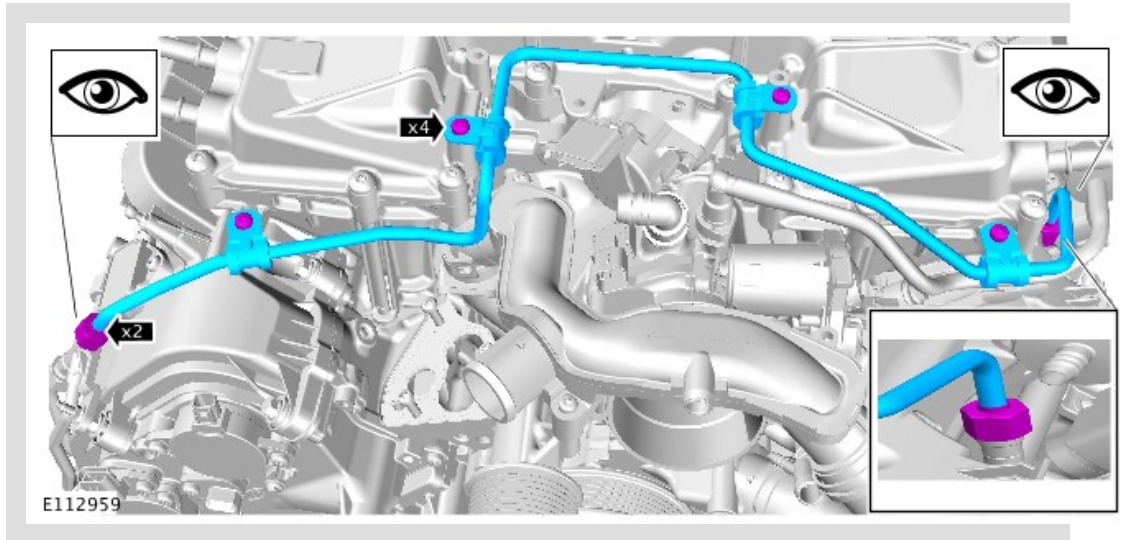

17.

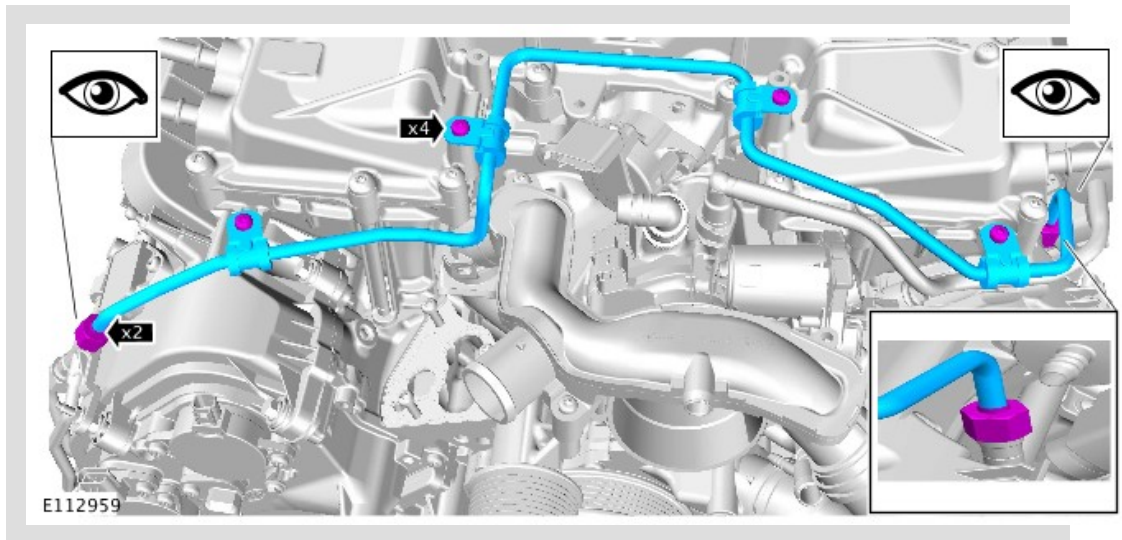

Torque:

Unions **21 Nm**

Bolts **8 Nm**

18.

Refer to: [Air Cleaner Outlet Pipe RH \(303-12C Intake Air Distribution and Filtering - V8 5.0L Petrol, Removal and Installation\)](#).

19.

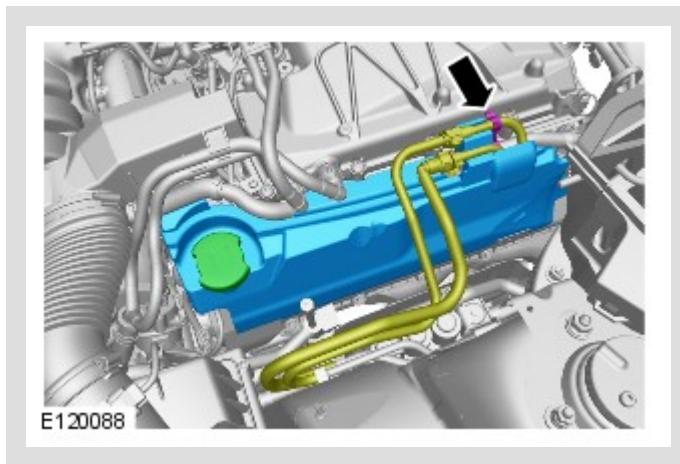

20.

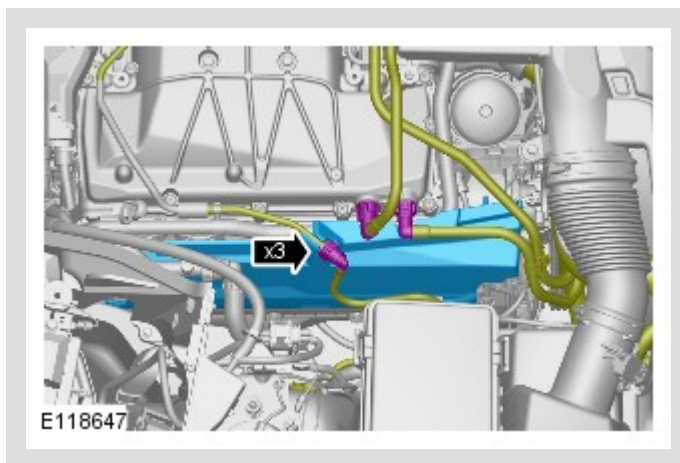

21. Refer to: [Engine Cover - V8 5.0L Petrol/V8 S/C 5.0L Petrol](#) (501-05 Interior Trim and Ornamentation, Removal and Installation).

22. Refer to: [Secondary Bulkhead Panel RH - TDV6 3.0L Diesel /V8 5.0L Petrol/V8 S/C 5.0L Petrol](#) (501-02 Front End Body Panels, Removal and Installation).

23. Refer to: [Secondary Bulkhead Panel LH - TDV6 3.0L Diesel /V8 5.0L Petrol/V8 S/C 5.0L Petrol](#) (501-02 Front End Body Panels, Removal and Installation).

24. Refer to: [Battery Disconnect and Connect](#) (414-01 Battery, Mounting and Cables, General Procedures).

