

# 2001 XJ RANGE - Front Suspension - 204-01

## Shock Absorber 60.30.04

### Special Service tools

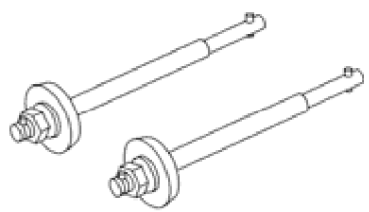

E36444

Front Camber Tie-down Link  
204-114 (JD 133)

### Removal

-  **CAUTION:**  
Replacement of nuts and bolts: Various thread-locking devices are used on nuts and bolts throughout the vehicle. These devices restrict the number of times a nut or bolt can be used. <<100-00>>

Raise the front of the vehicle. <<100-02>>

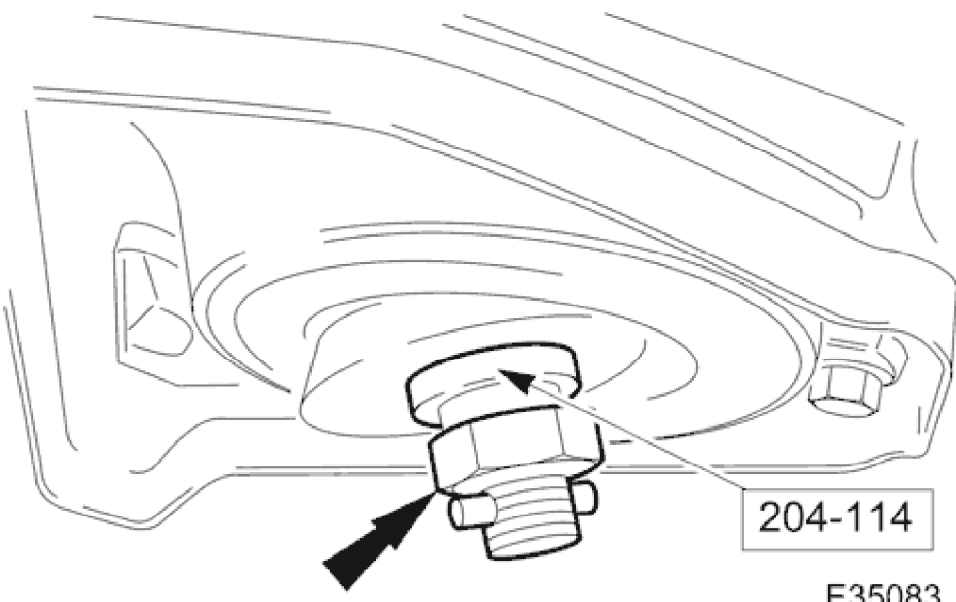

- Fully slacken the adjuster nut of the special tool 204-114 and position in the center of the road spring.

# 2001 XJ RANGE - Front Suspension - 204-01

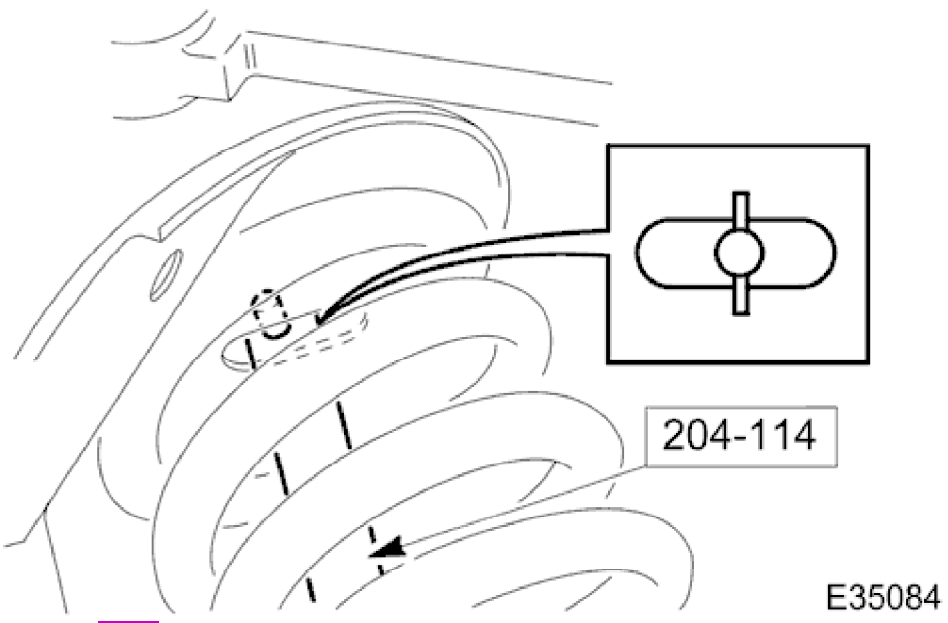

- 3.  **WARNING:**  
**ENSURE THAT THE DOWEL OF THE SPECIAL TOOL 204-114 IS CORRECTLY POSITIONED ACROSS THE SUSPENSION TURRET SLOT.**

Locate the special tool in the suspension turret slot.

- Pass the upper dowel through the slot in the suspension turret and rotate to locate the dowel.

- 4. Lower the front of the vehicle.

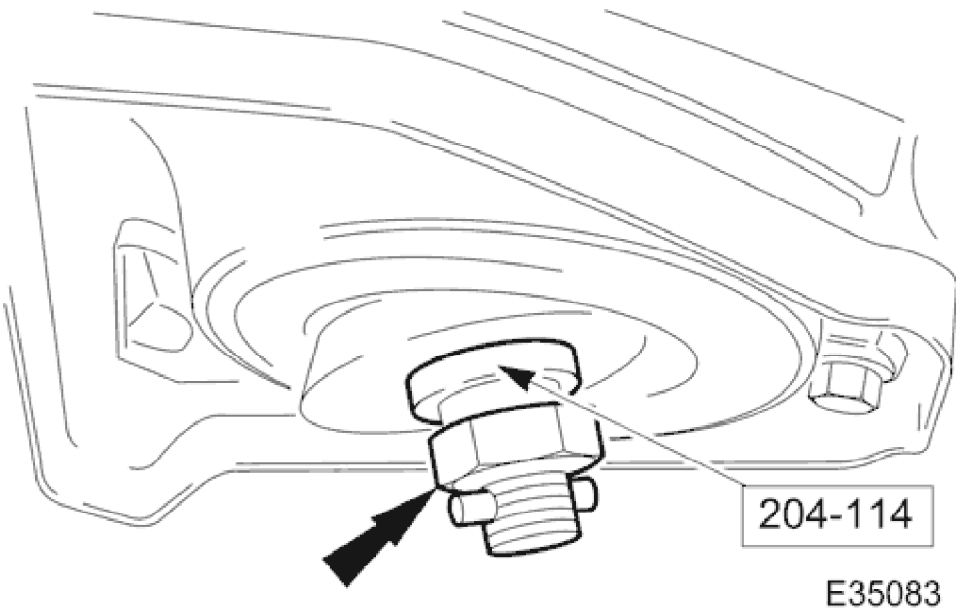

- 5.  **WARNING:**  
**WHEN TIGHTENING THE TOOL NUT, USE THE LOWER DOWEL AS A GUIDE TO ENSURE THAT THE TOOL STEM DOES NOT ROTATE AND DISTURB THE POSITION OF THE DOWEL IN THE**

# 2001 XJ RANGE - Front Suspension - 204-01

## SUSPENSION TURRET.

Tighten the nut of the special tool 204-114 to its full extent, to achieve a suspension mid-laden position.

- 6. Raise the front of the vehicle and support on axle stands. <<100-02>>
- 7. Remove the appropriate road wheel. <<204-04>>

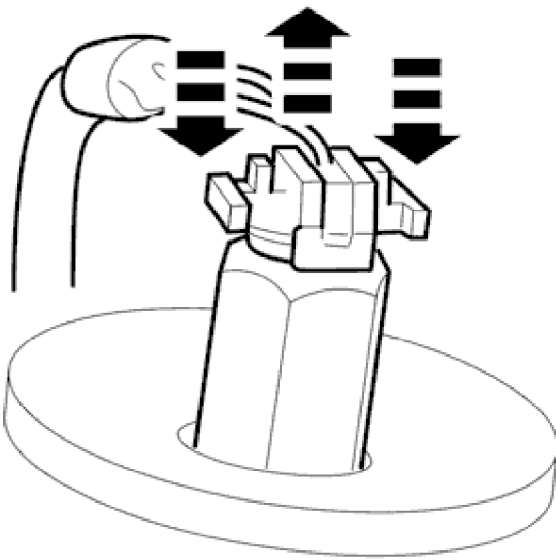

E35165

- 8. On vehicles with adaptive damping:
  - Disconnect the shock absorber electrical connector by pressing the lugs down and pulling the connector up.

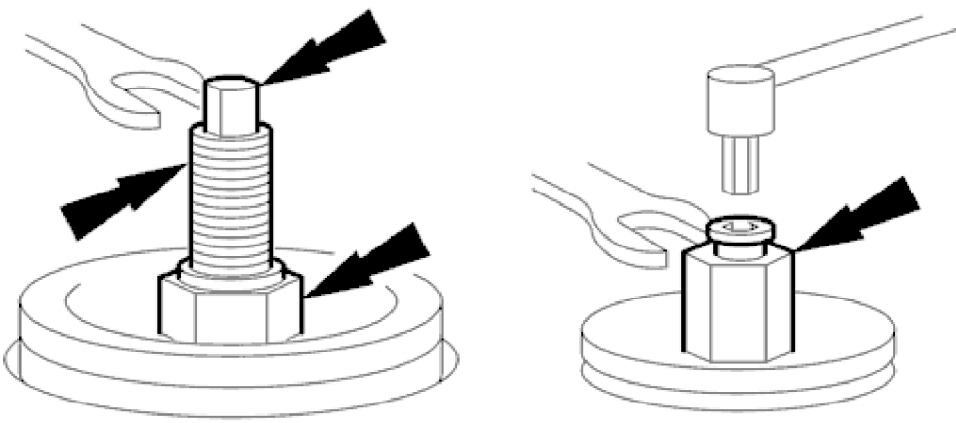

E35166

- 9. Remove the shock absorber from the upper mounting.
  - Position a wrench on the shock absorber shaft flats to prevent rotation (wrench in socket on vehicles with adaptive damping).
  - Remove the shock absorber upper retaining nut.

# 2001 XJ RANGE - Front Suspension - 204-01

- Remove the upper washer and isolator.

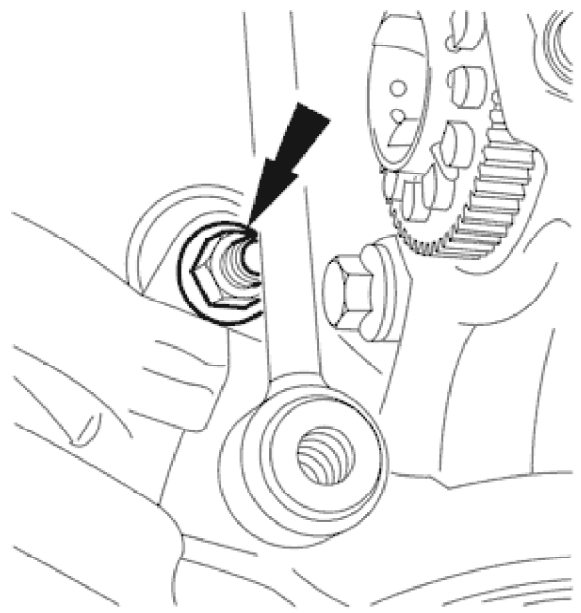

E35125

10. Detach the shock absorber.
- Remove the lower shock absorber retaining nut.
  - Remove the lower shock absorber retaining bolt.

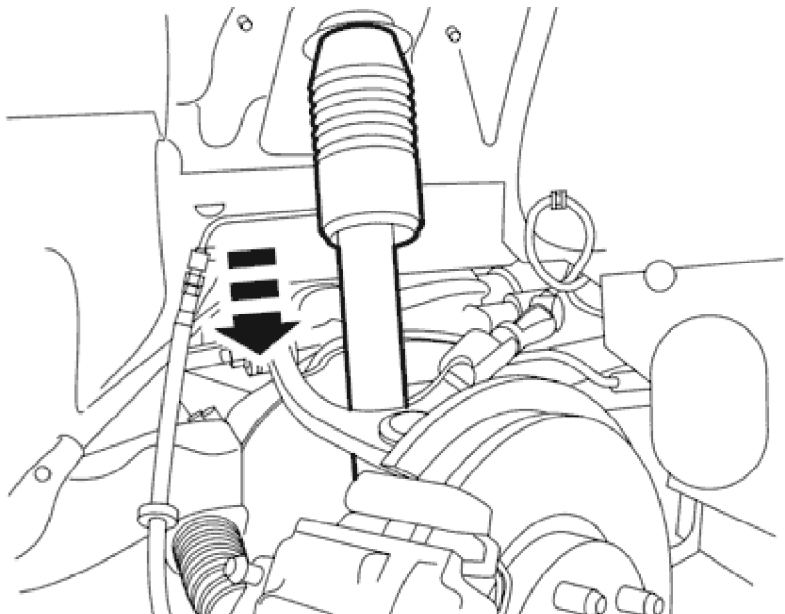

E42792

11. Remove the shock absorber through the lower wishbone.

## Installation

# 2001 XJ RANGE - Front Suspension - 204-01

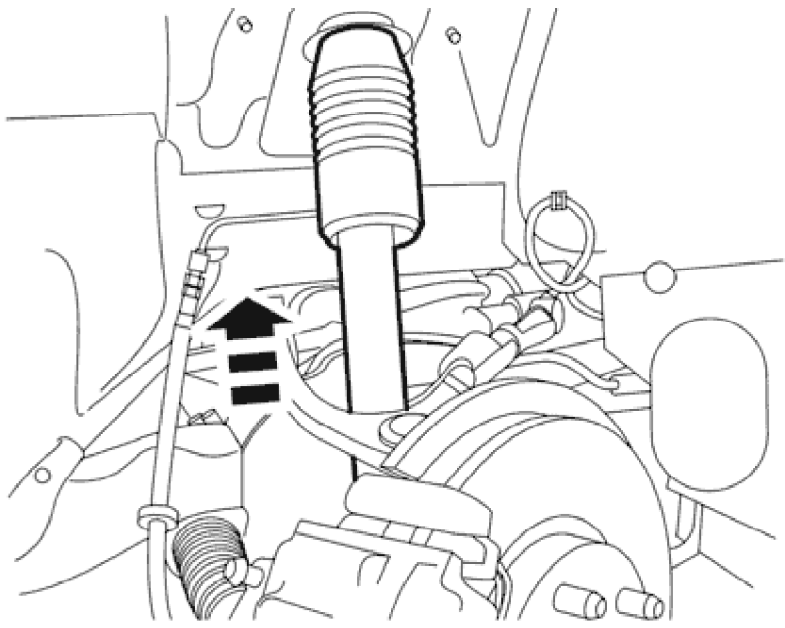

E42793

1. Install the shock absorber through the lower wishbone.

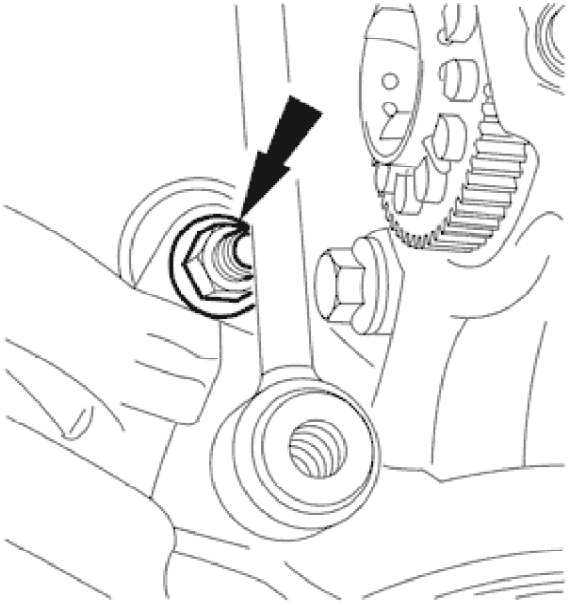

E35125

2. Attach the shock absorber.
- Install the lower shock absorber retaining nut.
  - Install the lower shock absorber retaining bolt.
  - Tighten to 43 to 57 Nm.

## 2001 XJ RANGE - Front Suspension - 204-01

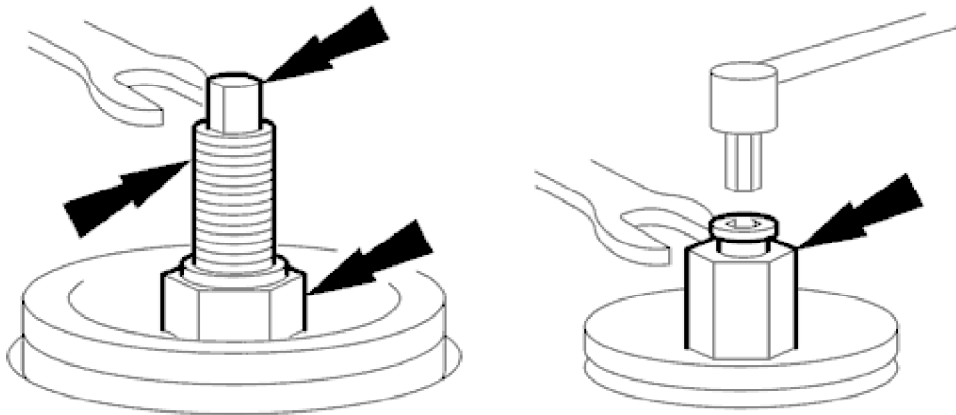

E35166

### 3. Attach the shock absorber to the upper mounting.

- Install the upper washer and isolator.
- Install the shock absorber upper retaining nut.
- Position a wrench on the shock absorber shaft flats to prevent rotation (wrench in socket on vehicles with adaptive damping).
- Tighten the shock absorber upper lock nut to 30-40 Nm (16-18 Nm on vehicles with adaptive damping).

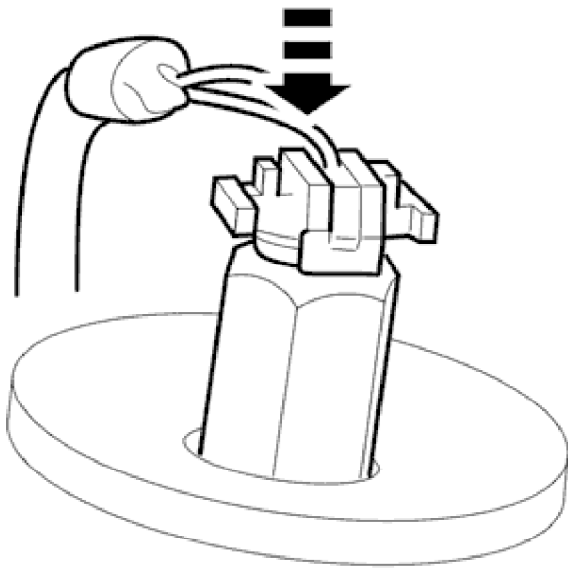

E35164



### 4. **CAUTION:**

**Make sure the adaptive damping electrical connector is correctly aligned. Failure to follow these instructions may cause damage to the electrical connector.**

On vehicles with adaptive damping:

- Connect the shock absorber electrical connector, ensuring the electrical connector key locates in the socket keyway.

# 2001 XJ RANGE - Front Suspension - 204-01

- 5. Fit the road wheel. <<204-04>>
- 6. Raise the vehicle, remove the axle stands and fully lower the vehicle. <<100-02>>

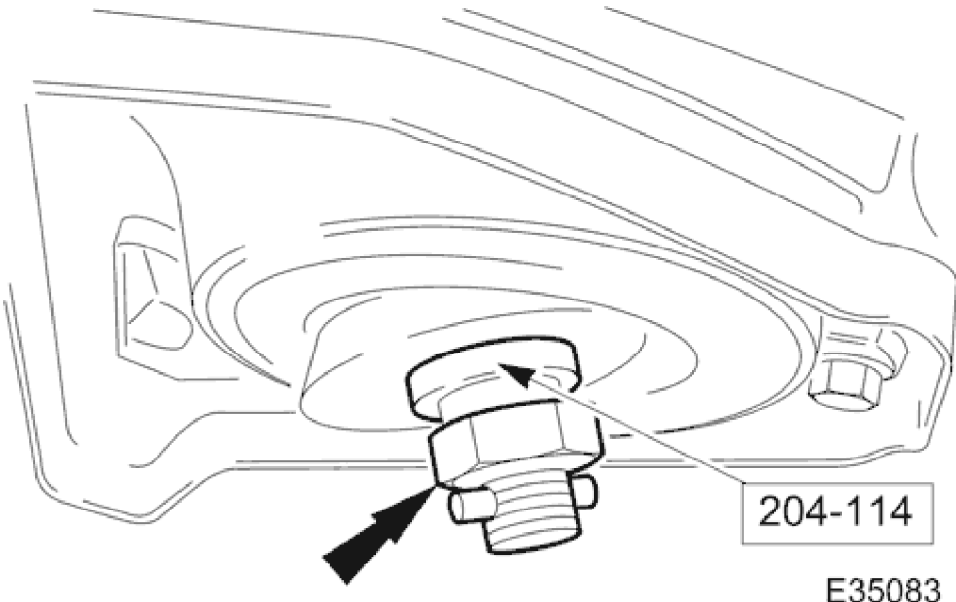

- 7. Fully slacken the adjuster nut of the special tool 204-114.

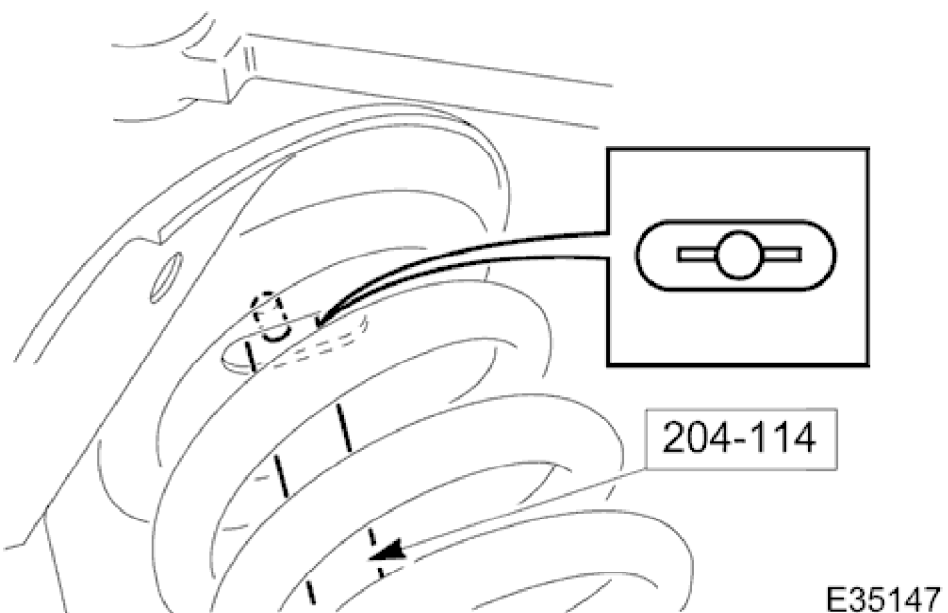

- 8. Rotate the special tool 204-114 to release the dowel from the suspension turret slot.
- 9. Raise the vehicle for access and remove the special tool 204-114 from the suspension.
- 10. Fully lower the vehicle.