

PUBLISHED: 11-MAY-2011
2016.0 XJ RANGE (X351), 501-12

INSTRUMENT PANEL AND CONSOLE

INSTRUMENT PANEL UPPER SECTION [G126974-0]

SPECIAL TOOL(S)

JLR-412-147



E125756

JLR-412-147

Remover, Register

REMOVAL



WARNINGS:

- To avoid accidental deployment, the restraints control module backup power supply must be depleted. Wait at least one minute after disconnecting the battery ground cable(s) before commencing any repair or adjustment to the supplemental restraint system (SRS), or any component(s) adjacent to the SRS sensors. Failure to follow these instructions may result in personal injury.
- Always wear safety glasses when working on an air bag equipped vehicle and when handling an air bag module. Failure to follow this instruction may result in personal injury.
- To minimize the possibility of premature deployment, do not use radio key code savers when working on the supplemental restraint system. Failure to follow this instruction may result in personal injury.
- To minimize the possibility of injury in the event of premature deployment, always carry a live air bag module with the bag and trim cover pointed away from the body. Failure to follow this instruction may result in personal injury.
- To minimize the possibility of premature deployment, live air bag modules must only be placed on work benches which have been ground bonded and with the trim cover facing up. Failure to follow these instructions may result in personal injury.
- Never probe the electrical connectors of air bag modules or any other supplemental restraint system component. Failure to follow this instruction may result in personal injury.
- Painting over the driver air bag module trim cover or instrument panel could lead to deterioration of the trim cover and air bags. Do not for any reason attempt to paint discolored or damaged air bag module trim covers or instrument panel. Install a new component. Failure to follow this instruction may result in personal injury.



NOTE:

Removal steps in this procedure may contain installation details.

1. Refer to: [Startup Battery Disconnect and Connect](#) (414-01 Battery, Mounting and Cables, General Procedures).

2. Refer to: [Steering Wheel](#) (211-04 Steering Column, Removal and Installation).

3.  **NOTE:**

The procedure must be carried out on both sides.

Refer to: [A-Pillar Trim Panel](#) (501-05 Interior Trim and Ornamentation, Removal and Installation).

4. Refer to: [Glove Compartment](#) (501-12 Instrument Panel and Console, Removal and Installation).

5. Refer to: [Instrument Cluster](#) (413-01 Instrument Cluster, Removal and Installation).

6. Refer to: [Instrument Panel Lower Section](#) (501-12 Instrument Panel and Console, Removal and Installation).

7. Fully extend the steering column for access.

8.  **NOTE:**

The procedure must be carried out on both sides.

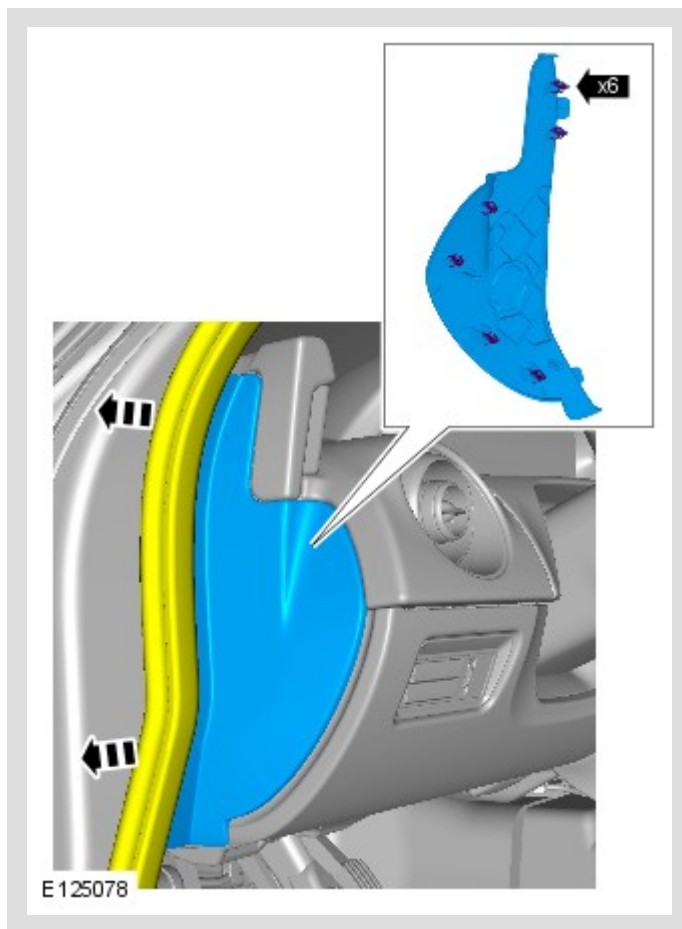

9.

 **NOTE:**

The procedure must be carried out on both sides.

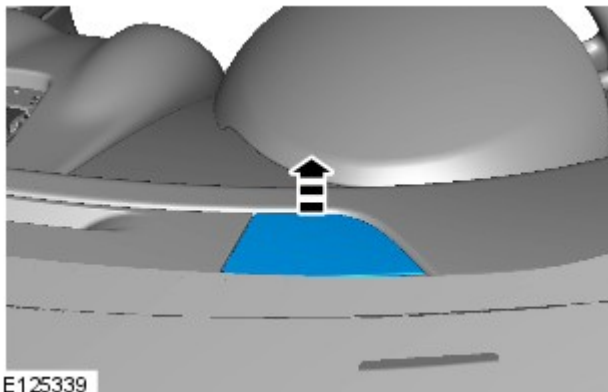

E125339

10.

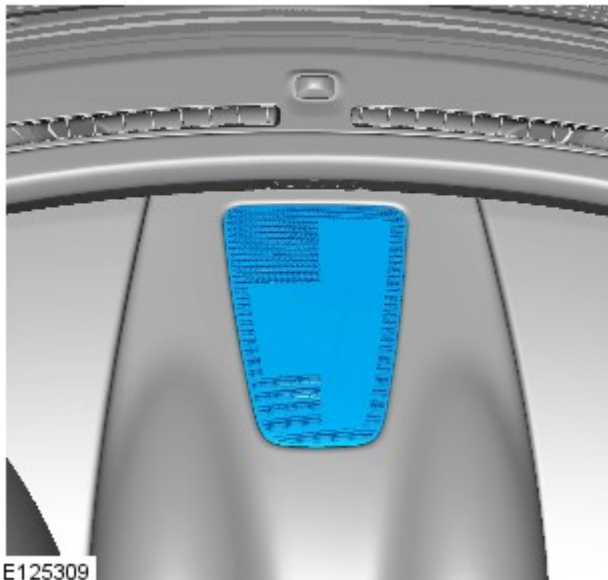

E125309

11.

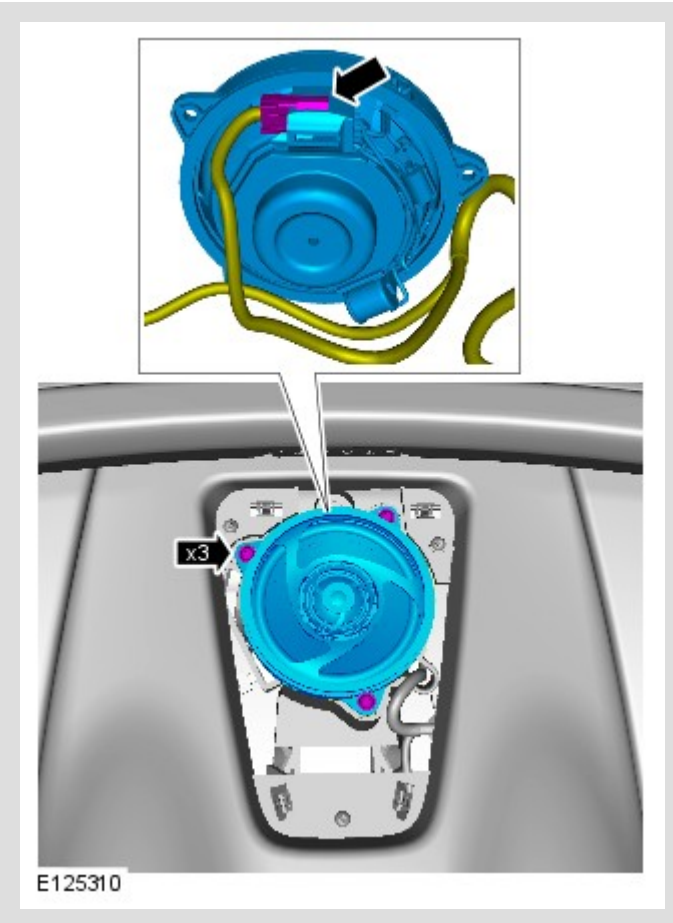

Torque: 2.5 Nm

12.

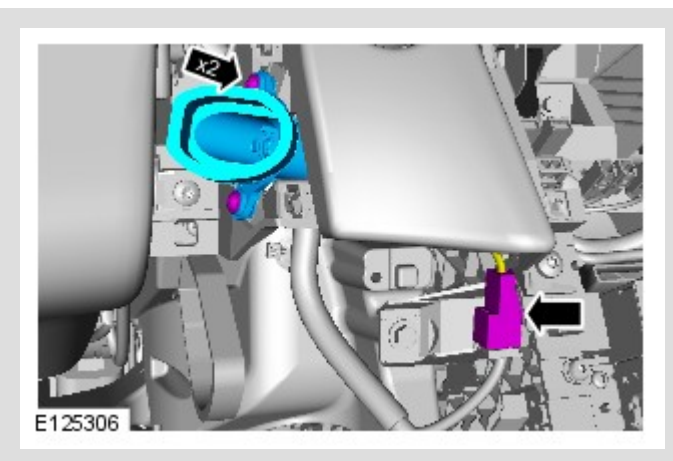

Torque: 2.5 Nm

! CAUTIONS:

- Before inserting the special tool, make sure that the register is fully open.
- Care must be taken to avoid damage to the internal components of the center registers.
- Repeat for the other centre register secured to the instrument panel.
- To install the register, align the securing clips and push the register into the housing until firmly secured in it's seated position.
- During removal, care must be taken not to damage the instrument panel covering with the register clips.

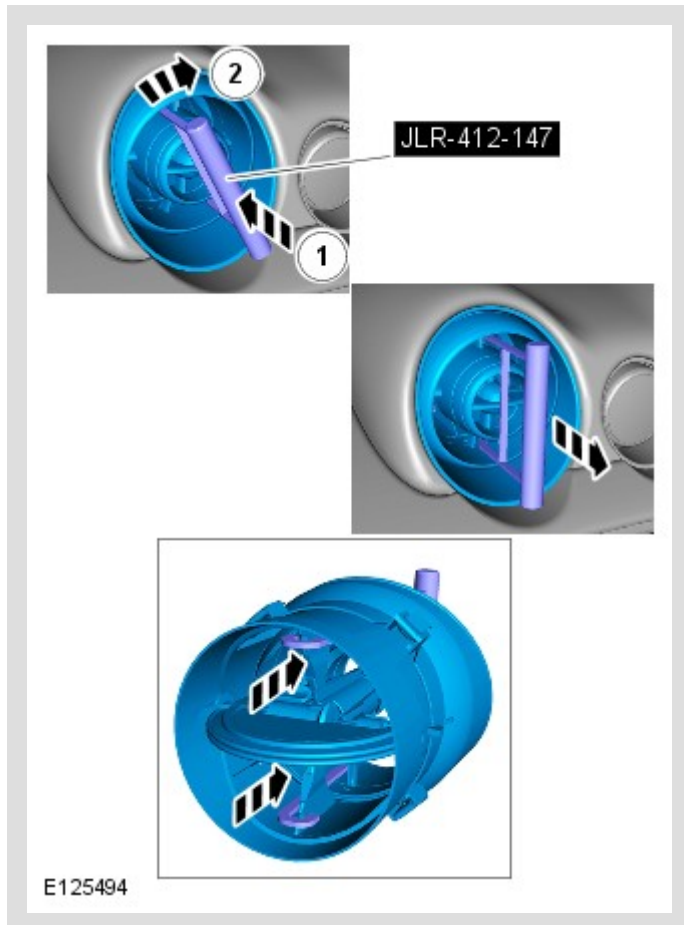

Special Tool(s): [JLR-412-147](#)

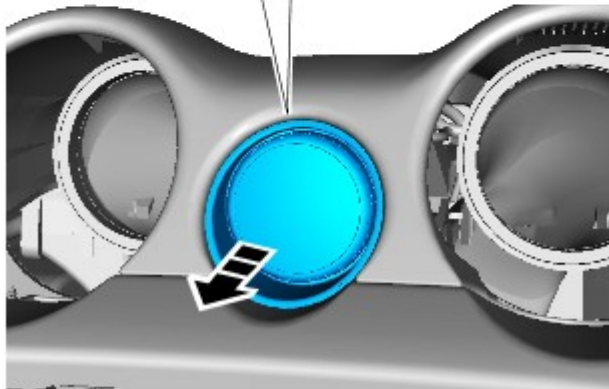
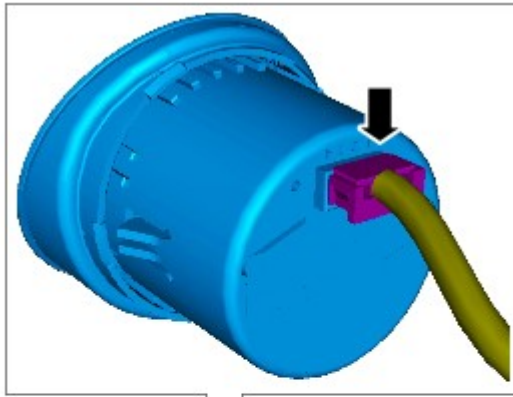

E125313

15.

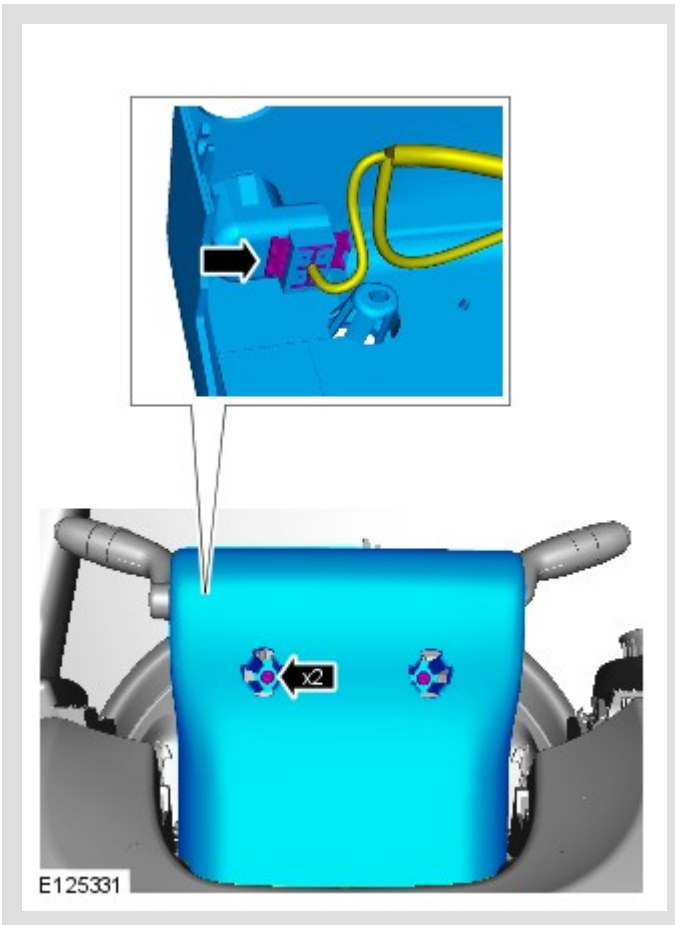

Torque: 2.5 Nm

16.

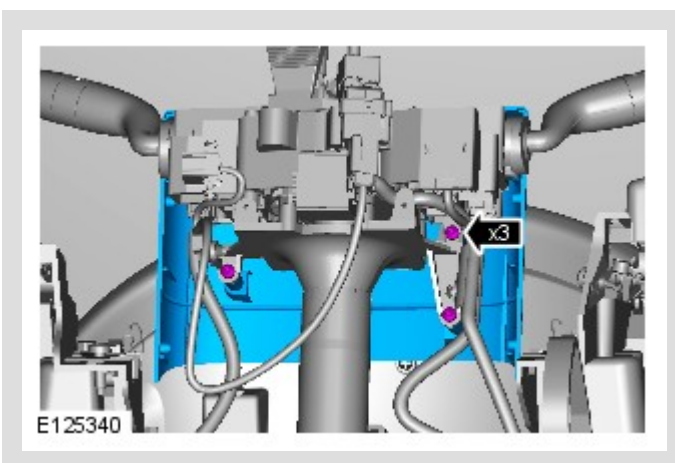

Torque: 2.5 Nm

17.

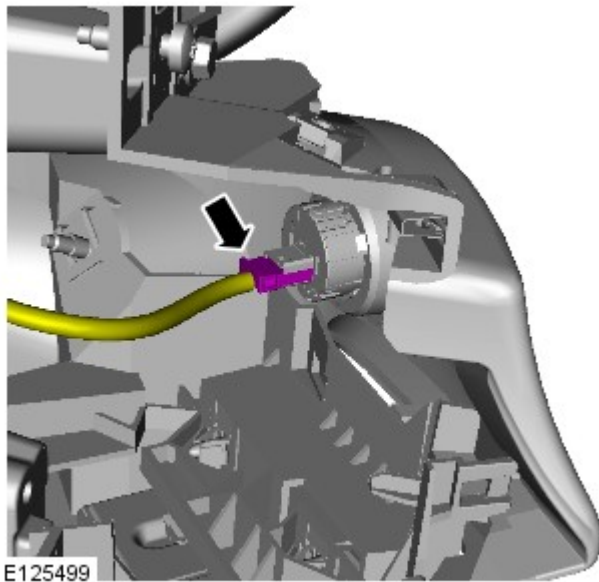

18.

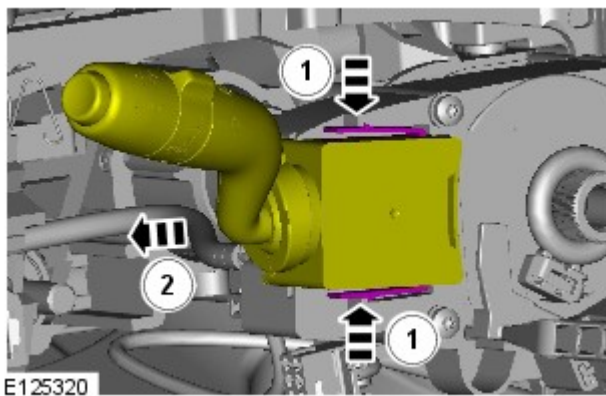

19.

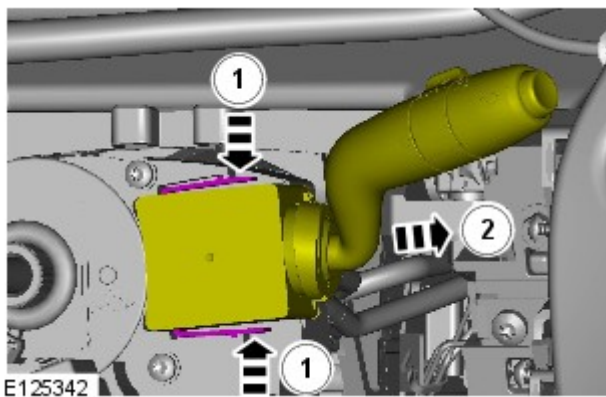

20.

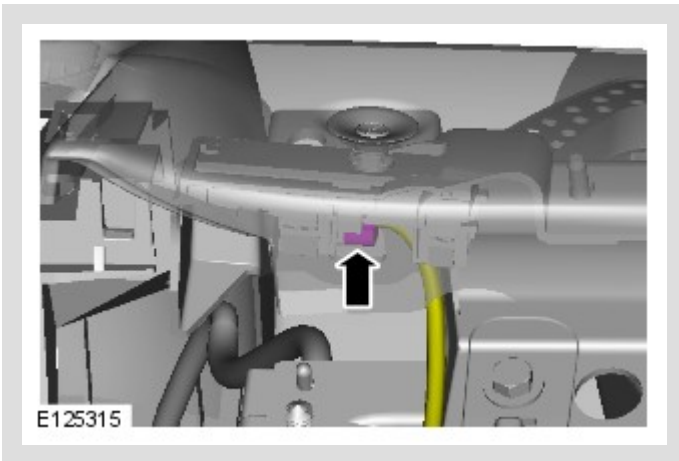

21.

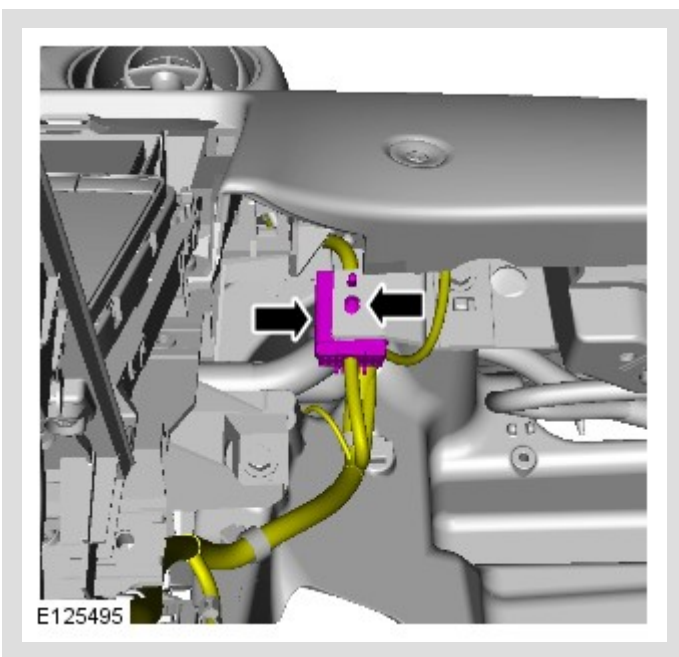

22.

 **NOTE:**

The procedure must be carried out on both sides.

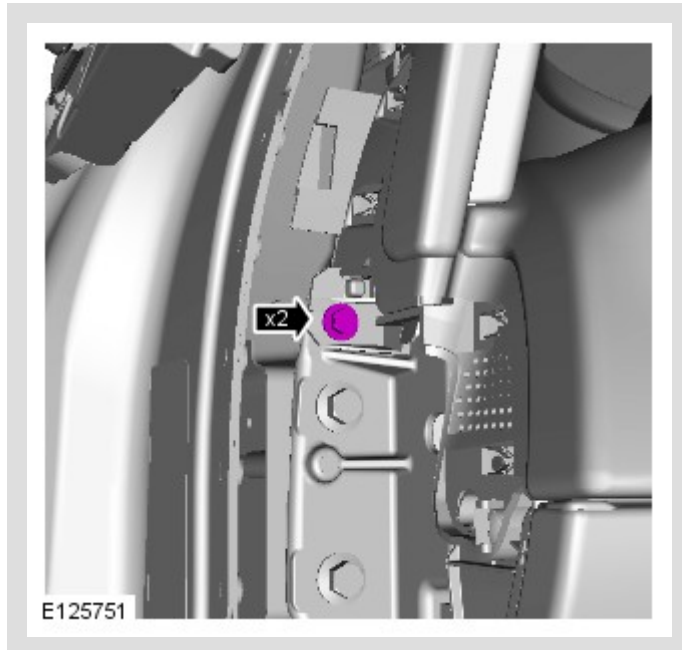

Torque: 9 Nm

23.

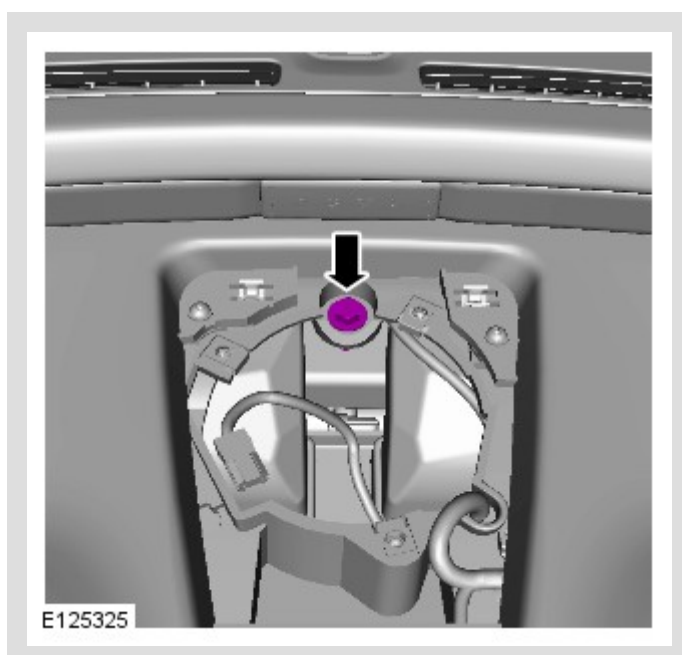

Torque: 9 Nm

24.

 **NOTE:**

The procedure must be carried out on both sides.

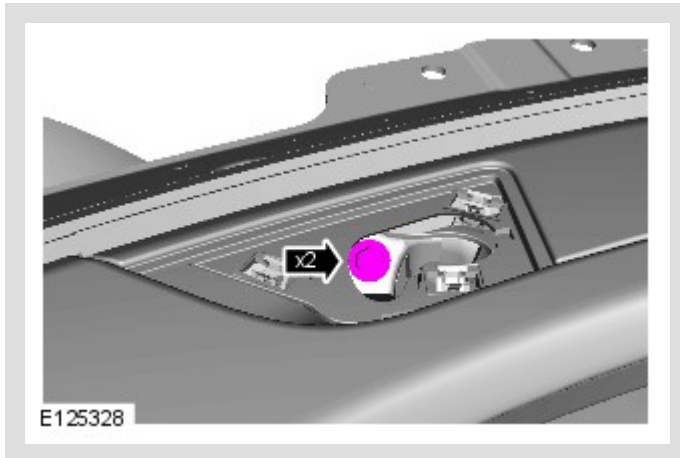

Torque: 9 Nm

25.

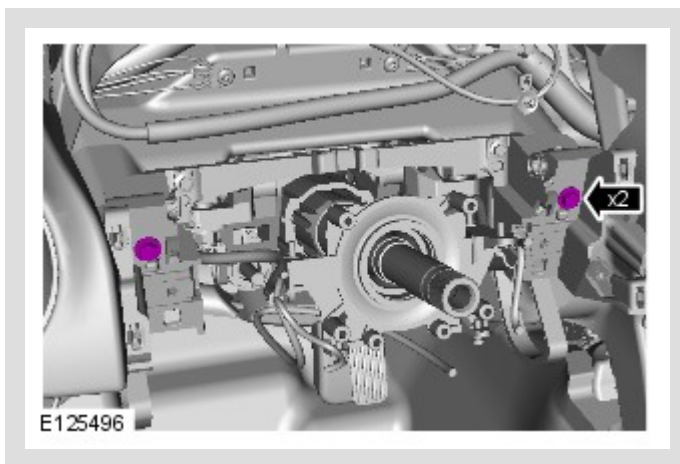

Torque: 9 Nm

26.

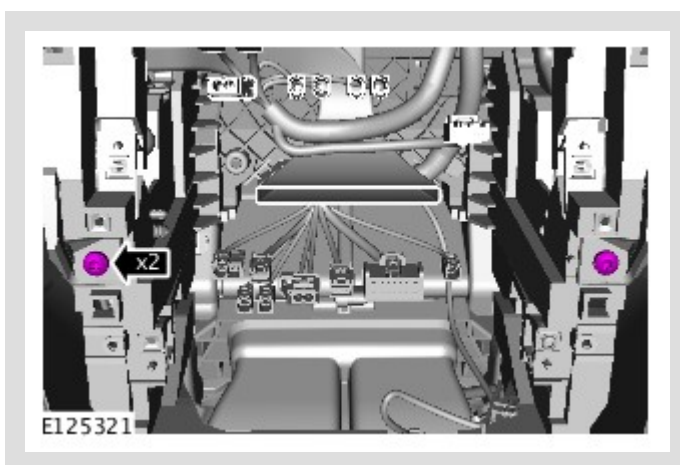

Torque: 4 Nm

27.

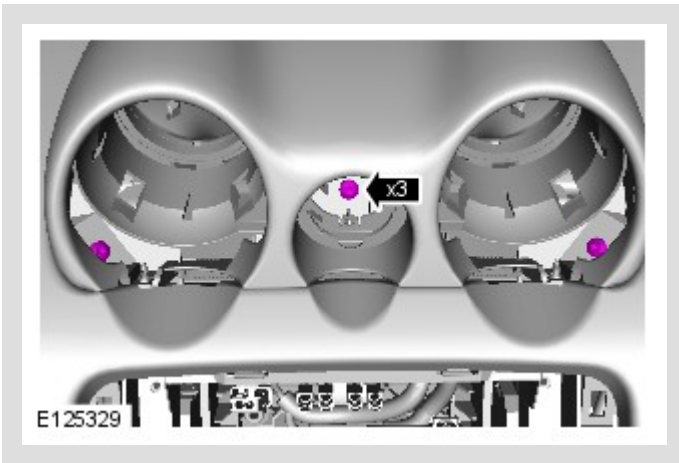

Torque: 4 Nm

28.

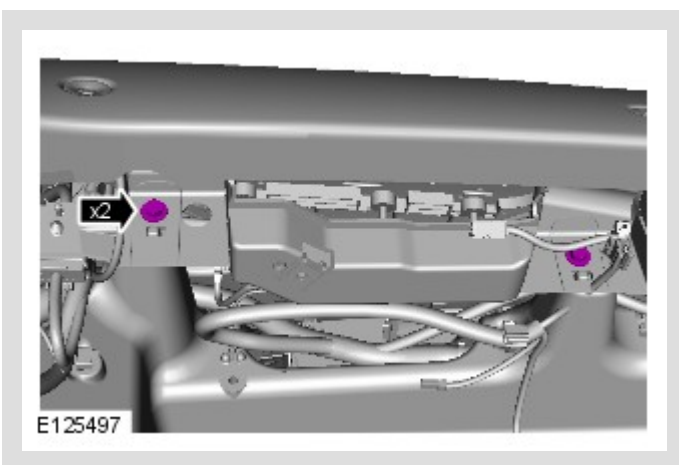

Torque: 9 Nm

29.

 **NOTE:**

Some variation in the illustrations may occur, but the essential information is always correct.

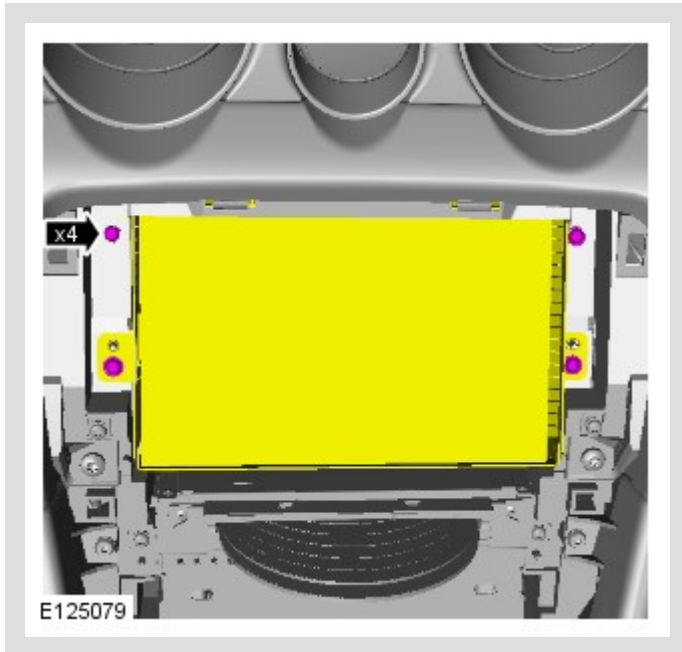

Torque: 4 Nm

30.

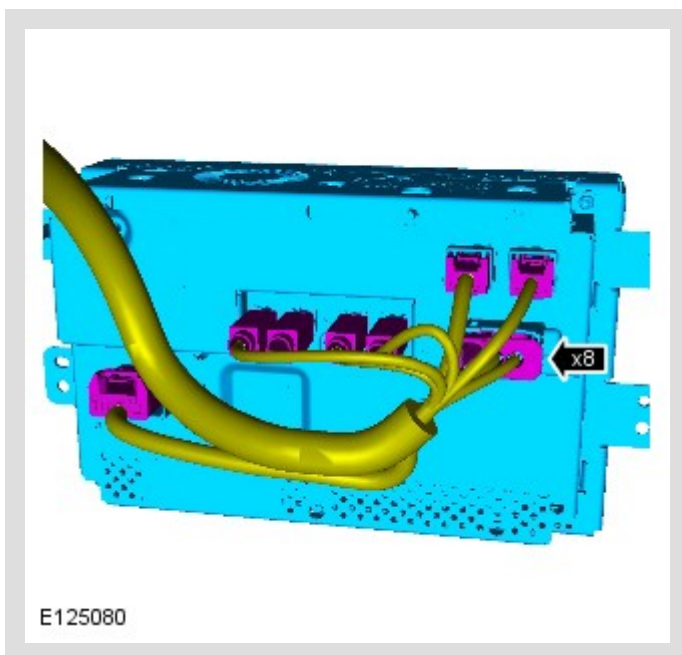

31.

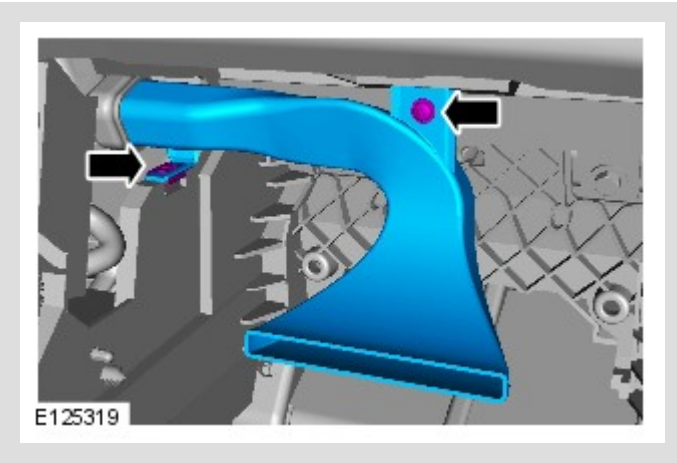

Torque: **2.5 Nm**

32.

⚠ CAUTION:

Note the fitted position of the component prior to removal.

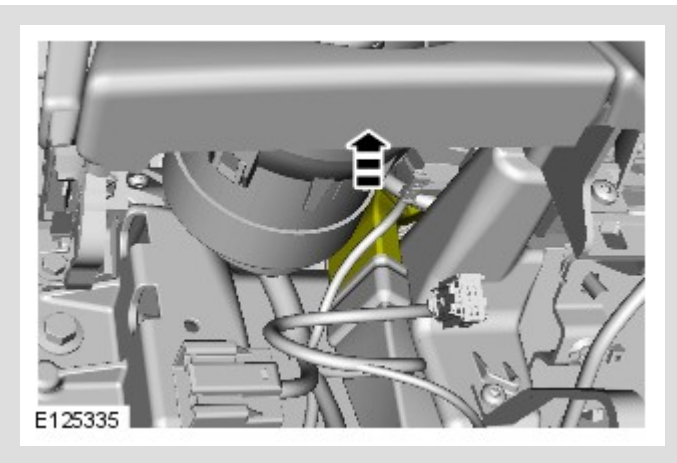

33.

 NOTE:

Some variation in the illustrations may occur, but the essential information is always correct.

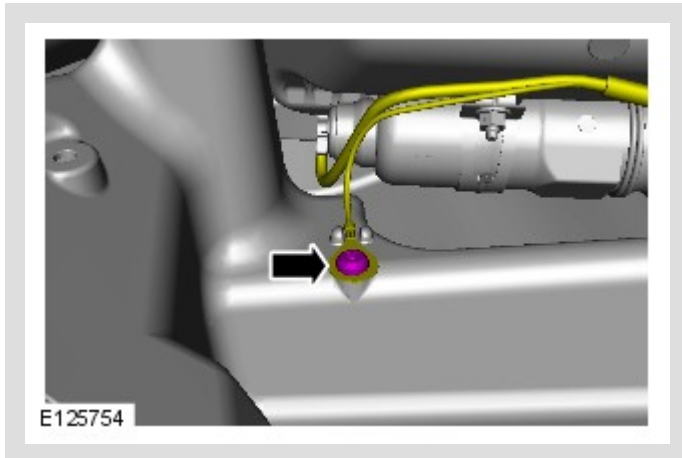

Torque: 9 Nm

34.

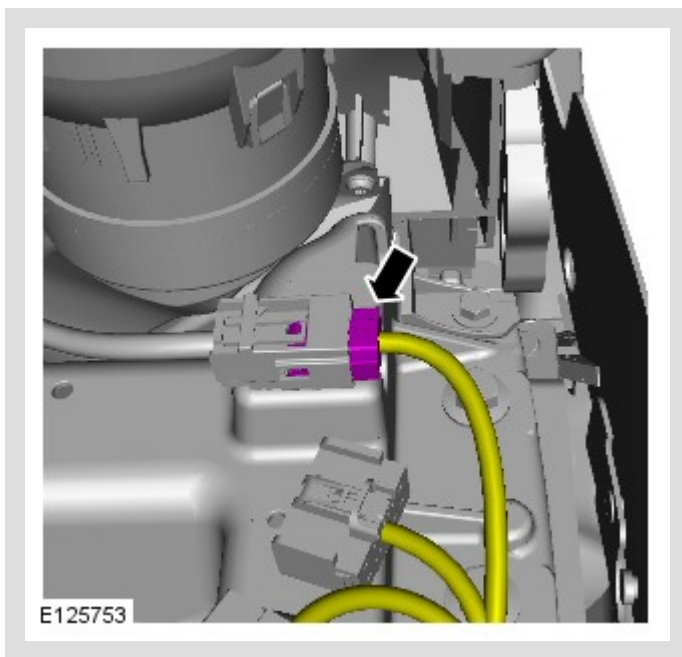

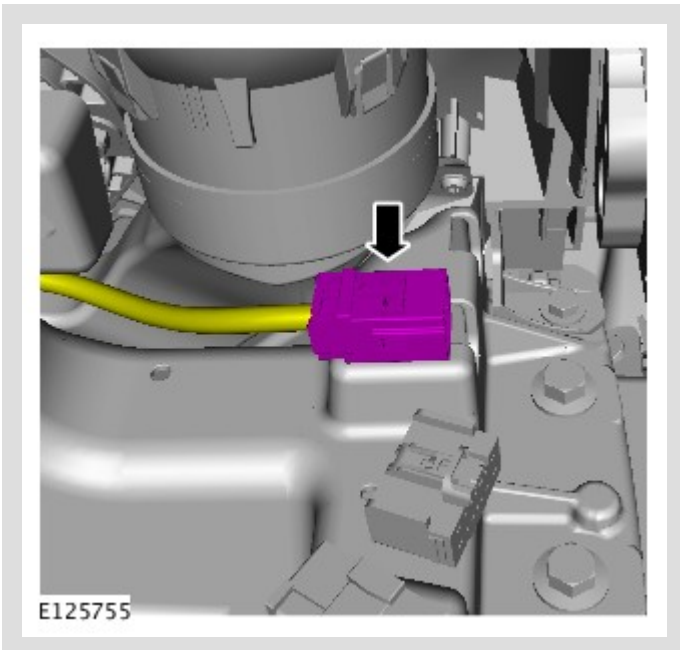

! CAUTIONS:

- Note the fitted position of the component prior to removal.
- Take extra care not to damage the edges of the component.

⚠ NOTES:

- This step requires the aid of another technician.
- LHD illustration shown, RHD is similar.

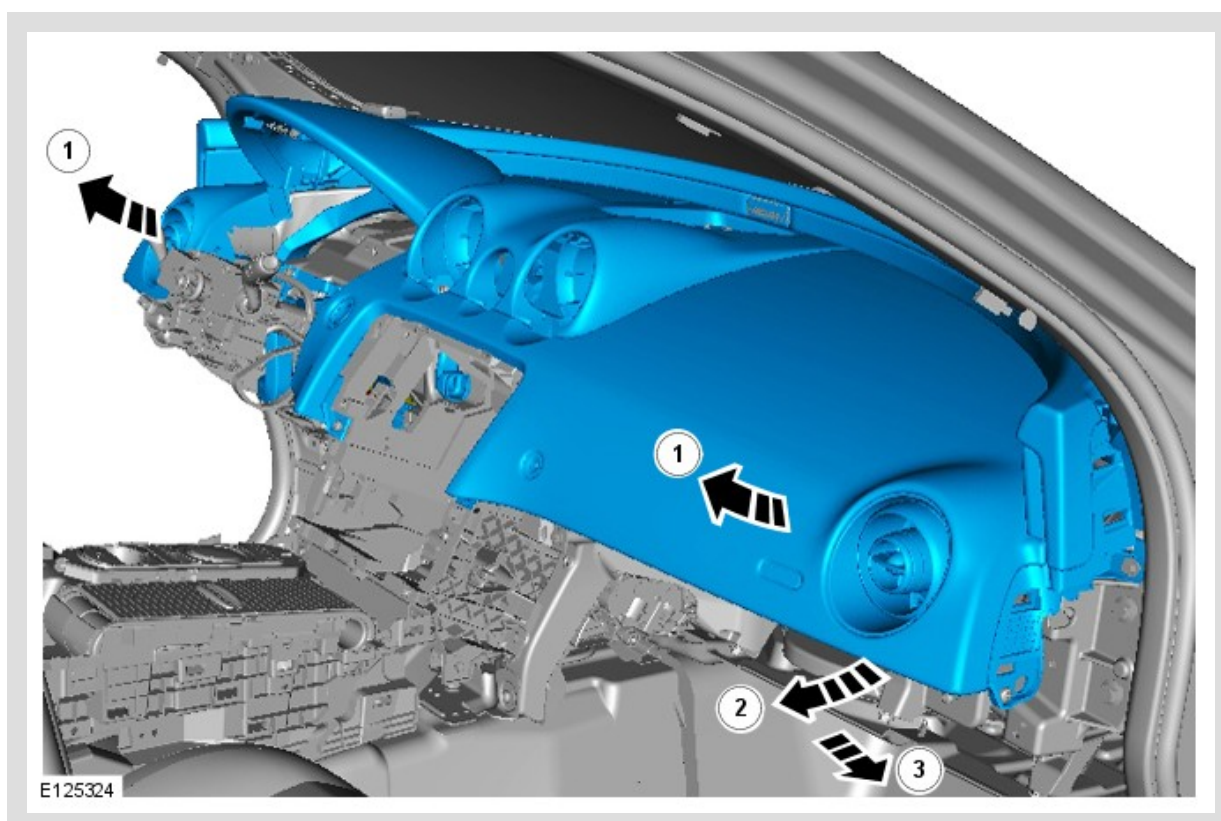

37.

 **NOTE:**

Do not disassemble further if the component is removed for access only.

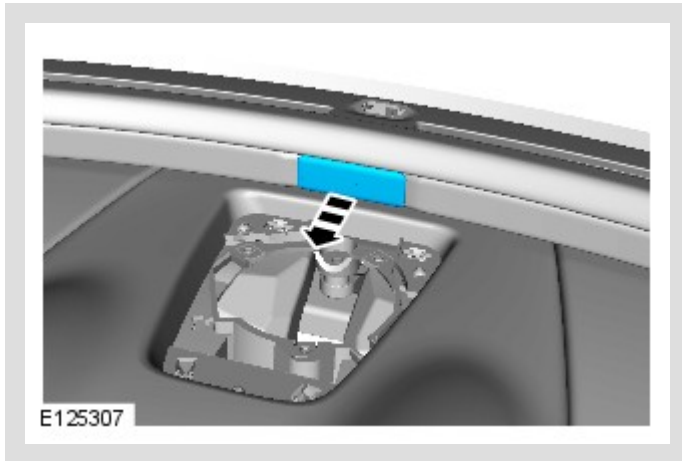

38.

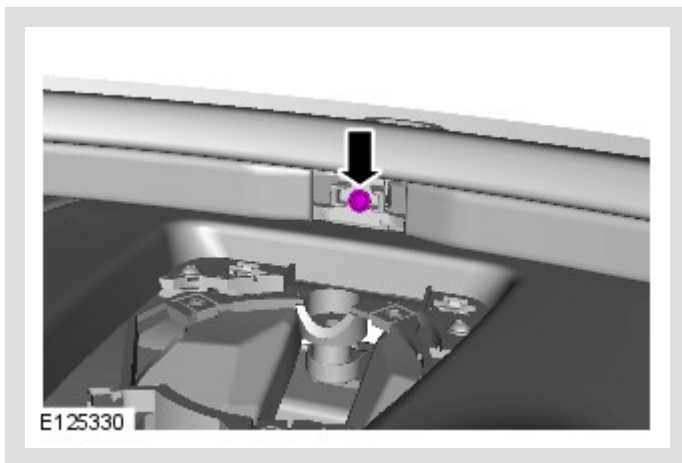

Torque: 2.5 Nm

39.

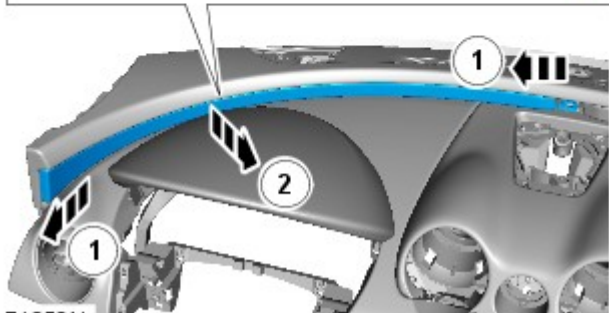
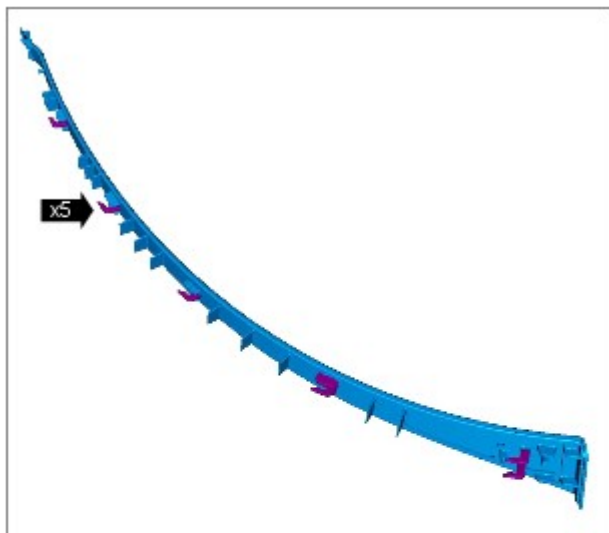

E125341

40.

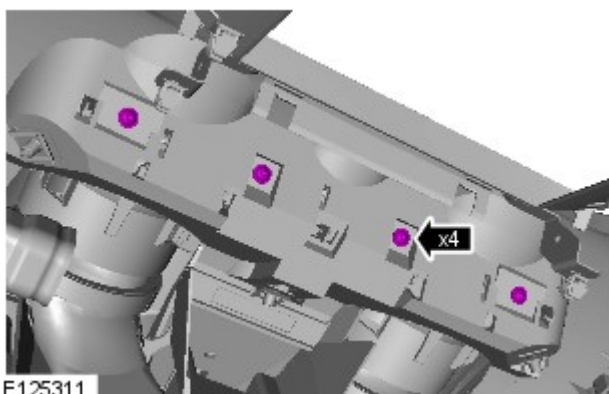

E125311

Torque: 2.5 Nm

4.1.

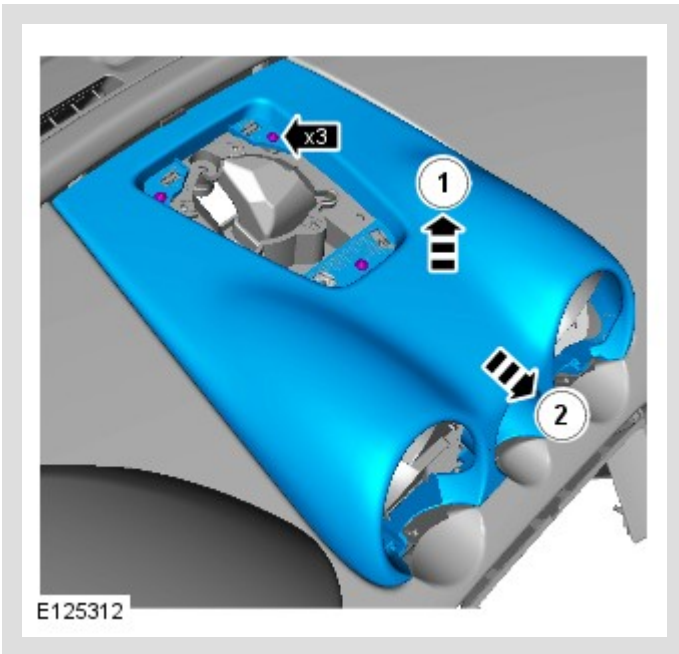

Torque: 2.5 Nm

4.2.

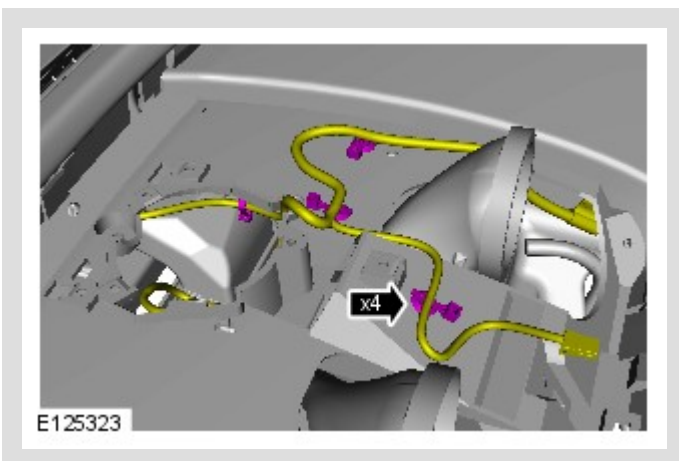

43.

⚠ CAUTION:

Note the fitted position of the component prior to removal.

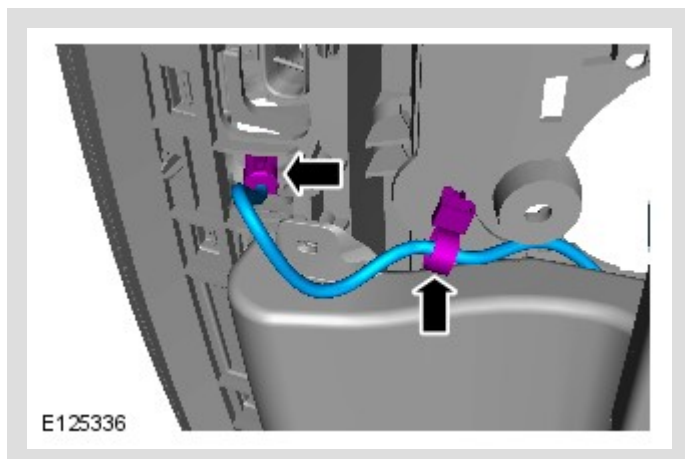

E125336

44.

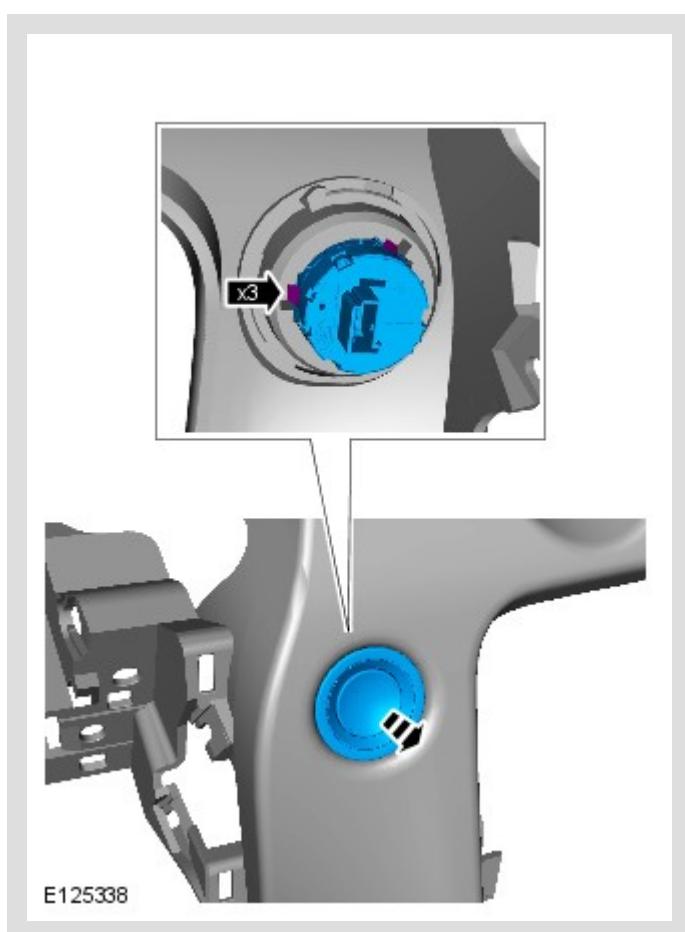

E125338

! CAUTIONS:

- Care must be taken to avoid damage to the seal register and running surface.
- Repeat for each of the registers secured to the instrument panel.
- Before inserting the special tool, make sure that the register is fully open.
- To install the register, align the securing clips and push the register into the housing until firmly secured in its seated position.
- During removal, care must be taken not to damage the instrument panel covering with the register clips.

△ NOTE:

Some variation in the illustrations may occur, but the essential information is always correct.



Special Tool(s): [JLR-412-147](#)

46.

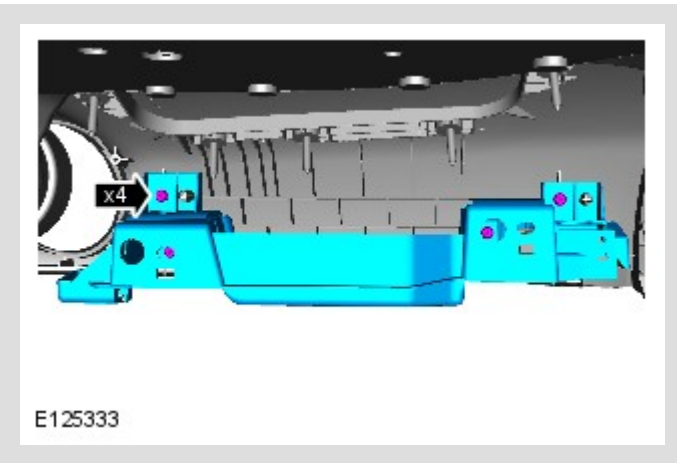

Torque: **2.5 Nm**

47.

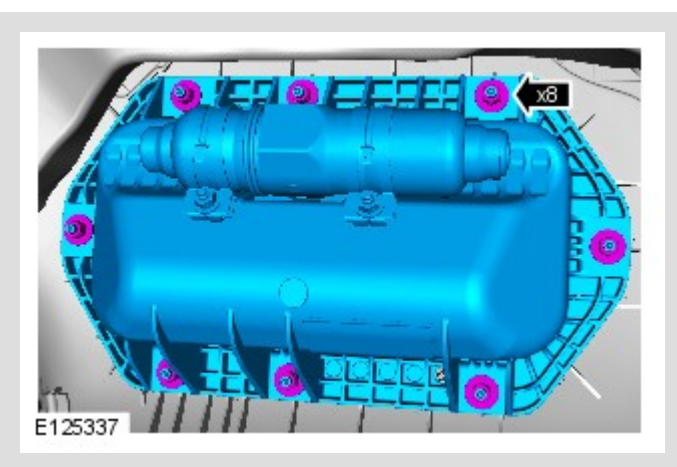

Torque: **4.5 Nm**

48.

 **NOTE:**

The procedure must be carried out on both sides.

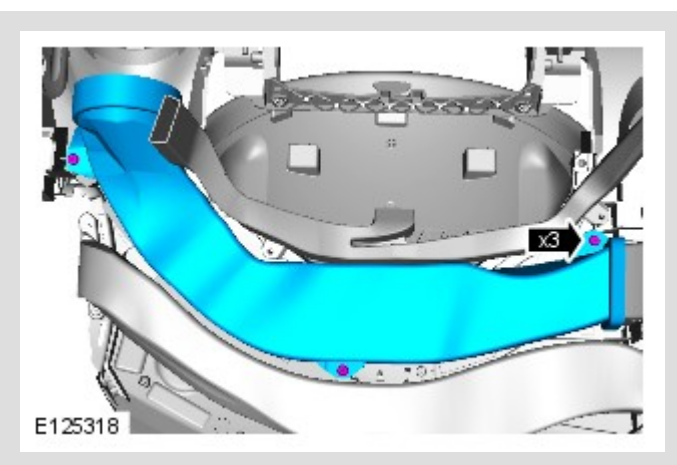

Torque: **2.5 Nm**

49.

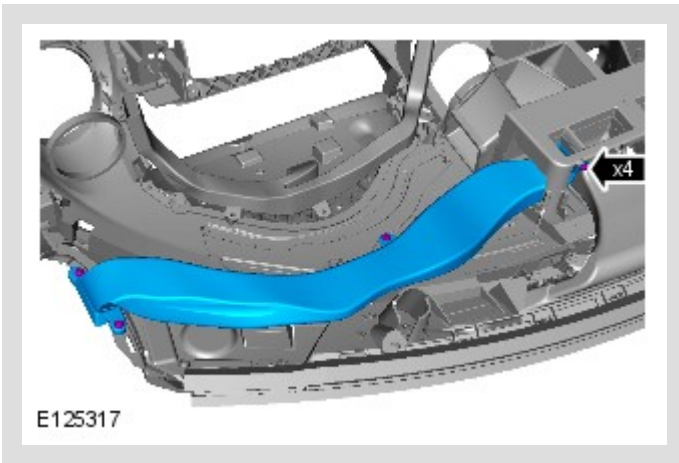

Torque: **2.5 Nm**

50.

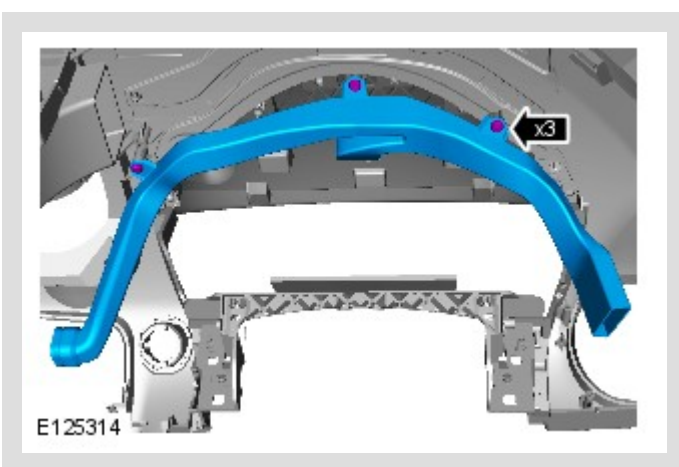

Torque: **2.5 Nm**

51.

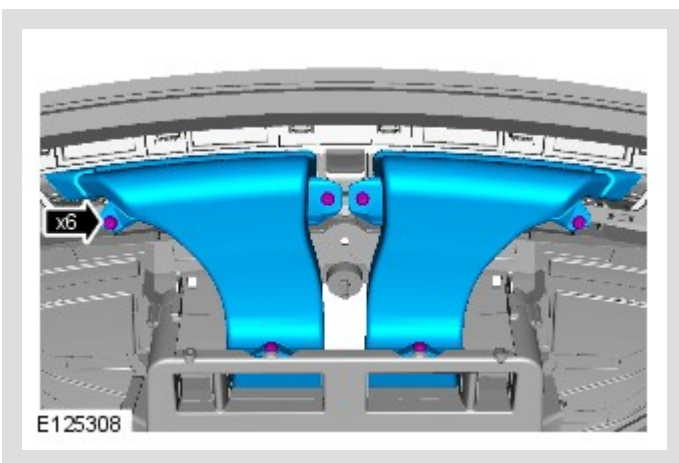

Torque: **2.5 Nm**

52.

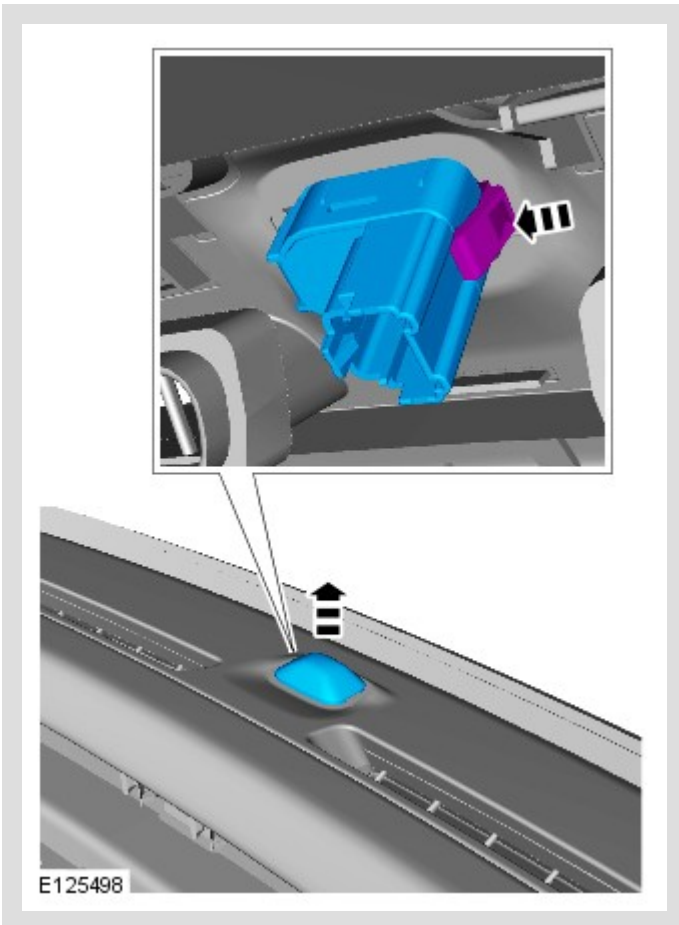

53.

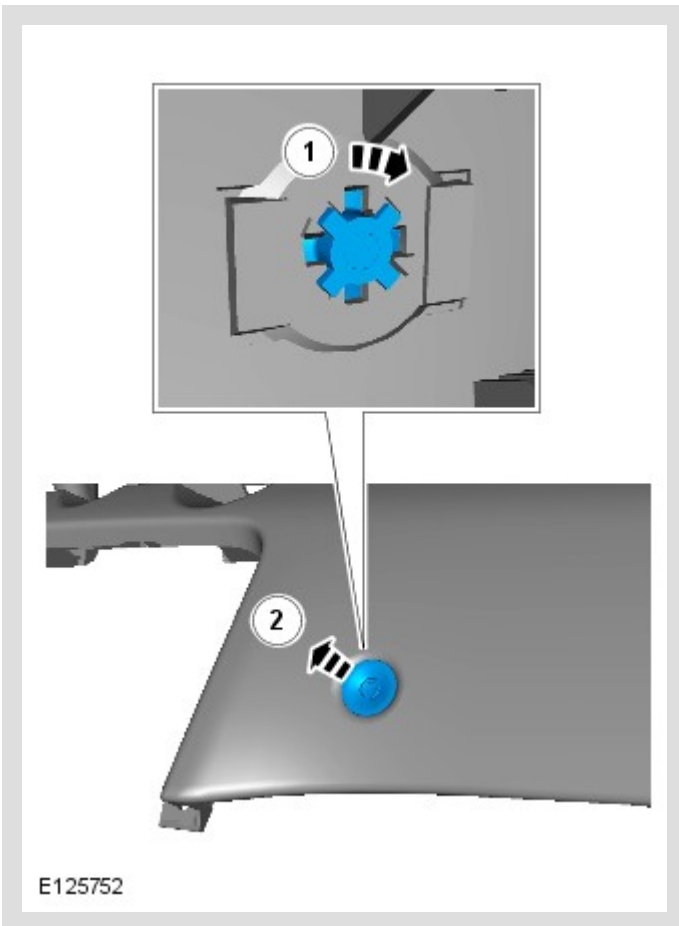

INSTALLATION

1. To install, reverse the removal procedure.

2.