

TIRE PRESSURE MONITORING SYSTEM

⚠ WARNING

TPMS provides a low pressure warning and does not re-inflate your tires. Tire pressures should be checked regularly, when cold, using an accurate pressure gauge.

⚠ WARNING

TPMS can NOT register damage to a tire. Regularly check the condition of your tires, especially if the vehicle is driven off-road.

NOTICE

When inflating tires, care should be taken to avoid bending or damaging the TPMS valves. Always ensure correct alignment of the inflation head to the valve stem.

Note: Non-approved accessories may interfere with the system. If this occurs, **TIRE PRESSURE MONITORING FAULT** is displayed in the message center.

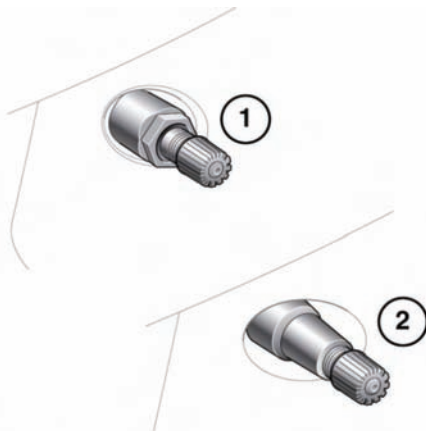

E132513

Wheels fitted with a TPM system can be visually identified by the external metal lock nut and valve (1). All Jaguar non-TPM system wheels have a rubber valve fitted (2).

TPMS OPERATION

The TPMS monitors pressure of the tires via sensors located in each wheel and a receiver located within the vehicle. Communication between sensor and receiver is via Radio Frequency (RF) signals.



The tire pressure warning comprises a yellow warning telltale within the instrument panel, and the associated messages within the message center.

Each tire, including the spare (if provided), should be checked monthly when cold and inflated to the inflation pressure recommended by the vehicle manufacturer on the vehicle placard or tire inflation pressure label. (If your vehicle has tires of a different size than the size indicated on the vehicle placard or tire inflation pressure label, you should determine the proper tire inflation pressure for those tires.) As an added safety feature, your vehicle has been equipped with a tire pressure monitoring system (TPMS) that illuminates a low tire pressure telltale when one or more of your tires is significantly under-inflated.

Accordingly, when the low tire pressure telltale illuminates, you should stop and check your tires as soon as possible, and inflate them to the proper pressure. Driving on a significantly under-inflated tire causes the tire to overheat and can lead to tire failure. Under-inflation also reduces fuel efficiency and tire tread life, and may affect the vehicle's handling and stopping ability.

Please note that the TPMS is not a substitute for proper tire maintenance, and it is the driver's responsibility to maintain correct tire pressure, even if under-inflation has not reached the level to trigger illumination of the TPMS low tire pressure telltale.

Tire pressure monitoring system (TPMS)

The TPMS may issue a warning if the under-inflation becomes significant. When driving through variable climatic conditions, the TPMS warnings may be intermittent.

Your vehicle has also been equipped with a TPMS malfunction indicator to indicate when the system is not operating properly.

The TPMS malfunction indicator is combined with the low tire pressure telltale. When the system detects a malfunction, the telltale will flash for approximately one minute and then remain continuously illuminated. This sequence will continue upon subsequent vehicle start-ups as long as the malfunction exists.

When the malfunction indicator is illuminated, the system may not be able to detect or signal low tire pressure as intended. TPMS malfunctions may occur for a variety of reasons, including the installation of replacement or alternate tires or wheels on the vehicle that prevent the TPMS from functioning properly. Always check the TPMS malfunction telltale after replacing one or more tires or wheels on your vehicle to ensure that the replacement or alternate tires and wheels allow the TPMS to continue to function properly.

A supplementary text message will accompany the system indicator and will display **TIRE PRESSURE MONITORING SYSTEM FAULT**.

TEMPORARY USE SPARE WHEEL AND TIRE CHANGE

If the temporary use spare wheel is fitted the system will automatically recognize the change in wheel positions. Then after approximately ten minutes of driving above 18 mph (25 km/h), a message detailing which tire is affected (e.g. **FRONT LEFT**) and **TIRE PRESSURE NOT MONITORED** will be displayed accompanied by illumination of the warning

telltale and the corresponding block in the vehicle graphic.

The warning telltale will initially flash and will subsequently revert to continuous illumination. Extended use of the temporary use spare wheel will produce an additional text message **TIRE PRESSURE MONITORING SYSTEM FAULT**.

This TPM system display sequence will be activated at every ignition cycle until the temporary use spare wheel is replaced by a fully operational full size wheel and tire assembly.

Always replace the temporary use wheel before having TPM system faults investigated. The fault may well be rectified with the installation of a fully operational full size running tire in lieu of the temporary use spare wheel assembly.

TIRE CHANGING

NOTICE

Always have your tires serviced or changed by a qualified technician.

Care must be taken to avoid contact between the bead of the tire and the sensor during removal and refitting of the tire, otherwise the sensor may become damaged and or inoperable.

NOTICE

Valve stem seal, washer, nut, valve core and cap should be replaced at every tire change. Valve stem seal, washer and nut must be replaced if valve retention nut is loosened. Sensor units and nuts must be refitted using correct torque figures and associated profile. Damage to the vehicle may result if these precautions are not taken.

Sensors can be removed from the wheel by the unscrewing of the valve retention nut.

REPLACEMENT SENSOR

Should the sensor require replacing, it should be carried out by a Dealer/Authorized Repairer.

A replacement sensor must be fitted to a running wheel in order to be recognized by the system. The vehicle needs to be stationary for 15 minutes during the sensor installation before the system is ready to detect the new sensor. The vehicle must be driven for a minimum of fifteen minutes after the sensor change, and then remain stationary for fifteen minutes to activate full TPM system operation.

If the TPM system warning for any wheel does not clear, even after ensuring correct inflation and driving for more than ten minutes above 18 mph (25 km/h), you should seek qualified assistance as soon as possible.

TYPE APPROVAL NUMBERS

United States of America

This device complies with part 15 of the FCC Rules. Operation is subject to the following two conditions:

- (1) This device may not cause harmful interference, and
- (2) this device must accept any interference received, including interference that may cause undesired operation.

Canada

This device complies with Industry Canada Standard IC - RSS-210: Operation is subject to the following two conditions:

- (1) this device may not cause interference, and
- (2) this device must accept any interference, including interference that may cause undesired operation of the device.

Note: *Changes or modifications not expressly approved by the manufacturer could void the user's authority to use the equipment.*

The TPMS radio frequency approval numbers for the USA and Canada are shown below:

USA FCC ID:	KR5S120123
	TX KR55WK47594
	RX 5WK4887
Canada IC:	267T-S120123
	267T-5WK47594
	CAN2671032336A