

TECHNICAL BULLETIN
JT B00368
15 JUL 2014



© Jaguar Land Rover Limited
All rights reserved.

SECTION: 501-17

Creaking Noises During Driving From The Panoramic Roof Centre Area,
Only When The Opening Panel Is In The Closed Position

AFFECTED VEHICLE RANGE:

XJ Range (X351)

Model Year: 2010-2014
VIN: V00001-V68703

MARKETS:

All

CONDITION SUMMARY:

Situation: Creaking noises from the rear edge of the roof opening panel area, only when the opening panel in the closed position, during vehicle torsional inputs. This bulletin is a potential addition to work described in campaign K117 as this particular concern will normally occur whilst driving over undulation in the road, such as, but not exclusively - drain covers, traffic calming measures and uneven road surfaces, with the roof panel closed.

Cause:

- The roof opening panel rear edge interior tooth feature comes into contact with the roof frame when closed.
- Movement between the sliding roof panel mechanism arm and the locking arm during torsional inputs to the vehicle.

Suggested Customer Concern Code - J03.

Action: Should a customer express concern, follow the Service Instruction outlined below.

PARTS:

| | | |
|----------|---------|-------------|
| C2D38990 | Insert. | Quantity: 2 |
| C2D40864 | Oil | Quantity: 1 |
| C2D40865 | Grease | Quantity: 1 |

TOOLS:

No Tools Required

WARRANTY:

NOTE: Repair procedures are under constant review, and therefore times are subject to change; those quoted here must be taken as guidance only. Always refer to TOPIx to obtain the latest repair time.

NOTE: DDW requires the use of causal part numbers. Labor only claims must show the causal part number with a quantity of zero.

| DESCRIPTION | SRO | TIME (HOURS) | CONDITION CODE | CAUSAL PART |
|---------------------------------------|-----------------|--------------|----------------|-------------|
| Roof Opening Panel Creak Repair. | 76.96.20 | 0.7 | 07 | C2D30275 |
| Roof Opening Panel Creak Repair (LWB) | 76.96.20 | 0.7 | 07 | C2D30276 |

NOTE: Normal Warranty procedures apply.

SERVICE INSTRUCTION:

NOTE: The procedure must be carried out on both sides of the roof opening panel.



NOTE: Please note this bulletin is supplementary to campaign K117 but may not be appropriate for all reported customer concerns.

1 Remove the roof opening panel glass (see TOPIx Workshop Manual, section 507-17).

Vin range V24464 to V59436.

2 With a suitable tool, remove the outer section of trim as shown.

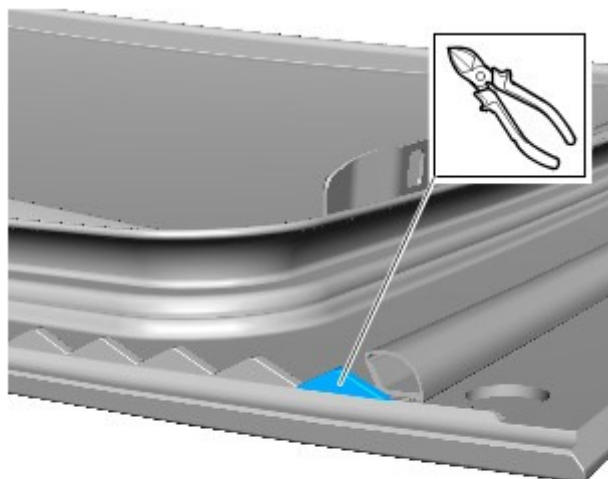

E162053

All vehicles.

3 Cut and remove the front section of the seal as shown.

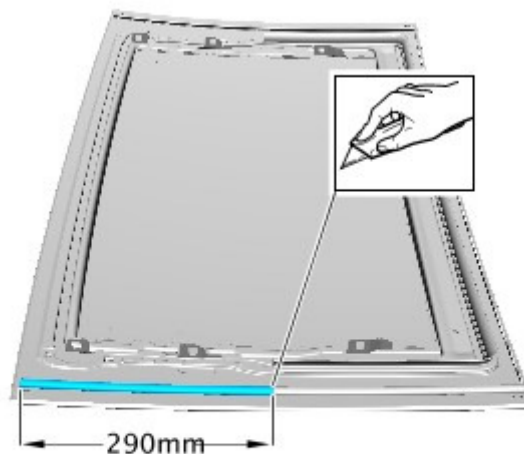

E164042

4 Clean the area shown of any residue.

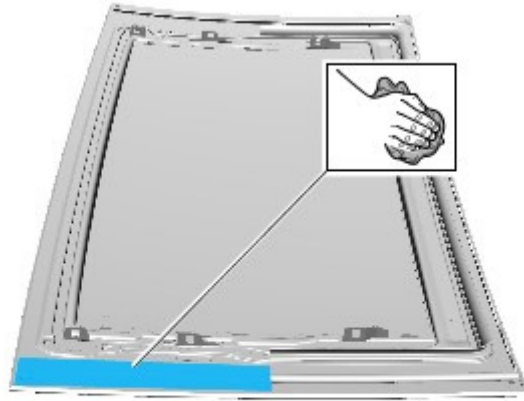

E164041

5  **CAUTION: When carrying out this step take care not to disengage the spring.**

! **CAUTION: Do not use any cleaning solution in this step.**

Raise the roof opening panel regulator arms into the vent position and clean them with a suitable cloth.

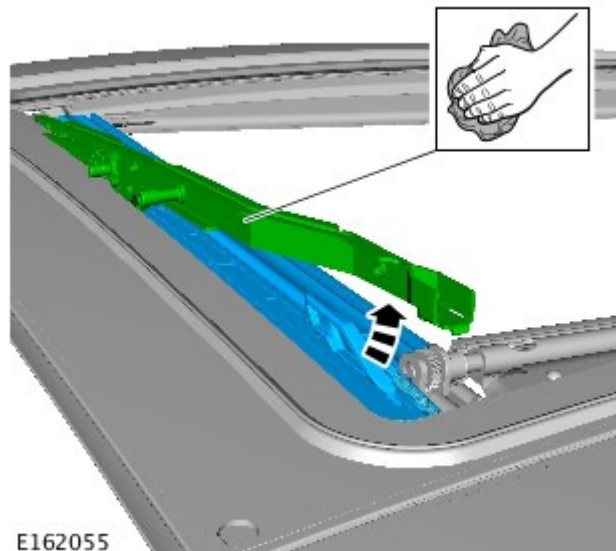

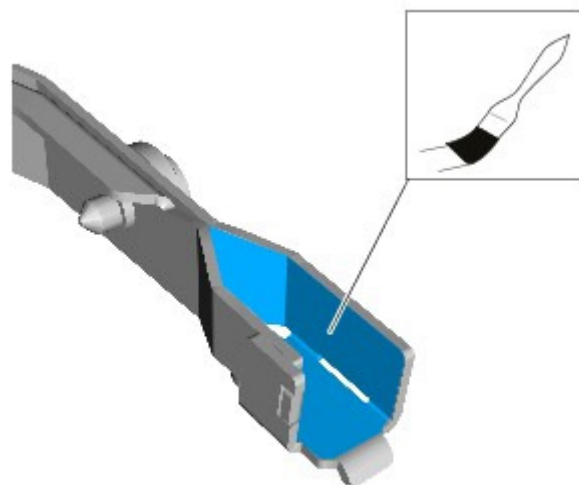

E162055

6 Using a suitable small brush, lubricate the opening roof panel regulator arm with grease.



E164227

7  **CAUTION:** When fitting the insert, make sure the rubber buffer is correctly located and not trapped between the insert and the roof opening panel regulator arm.

 **NOTE:** Make sure the sliding roof panel regulator arm is clean before installing the insert.

Install the insert into the roof opening panel regulator arm as shown.

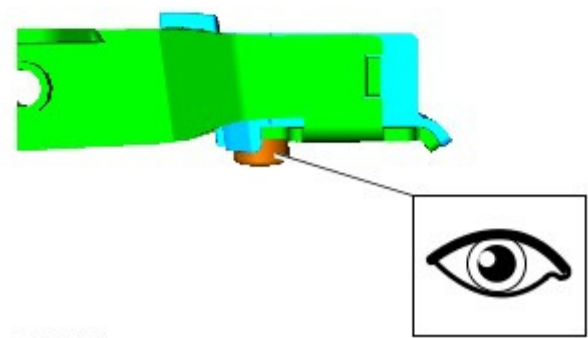
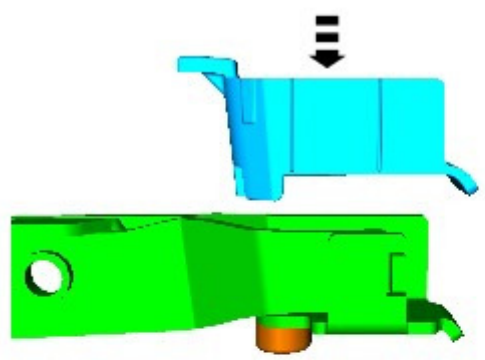

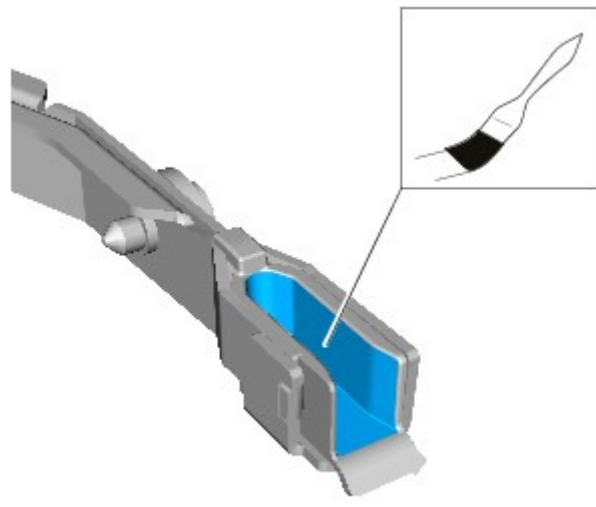

E162054

8 Using a suitable small brush, lubricate the insert with grease.





E162601

9  **CAUTION:** Remove the excess lubrication oil from a suitable brush before applying sparingly to the slider channel. Failure to comply with this guidance may contaminate trim components.

 **CAUTION:** Make sure when applying the oil that it is applied to the slider channel only and not the surrounding components.

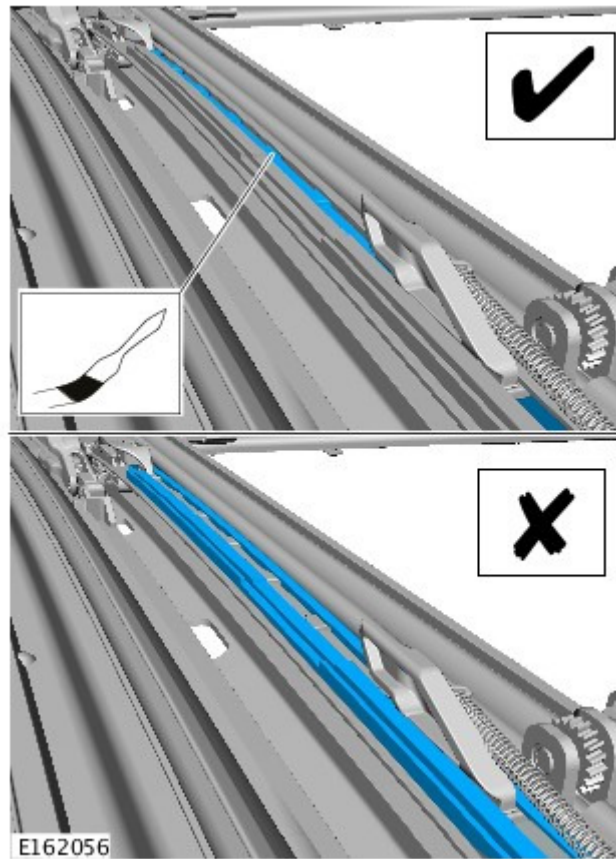
Lubricate the roof opening panel slider channel with the recommended oil.



- 10**  **CAUTION:** When carrying out this step take care not to disengage the spring.

 **NOTE:** Make sure sufficient lubricating oil penetrates in between the locking arm and guide rail as shown.

Move the locking arm back and forwards to distribute the lubricating oil.

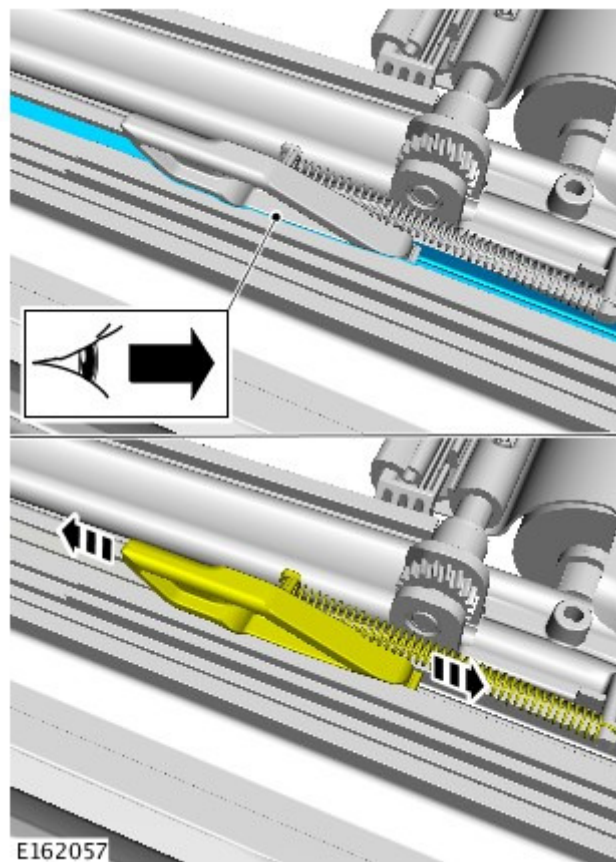

- 11** Using a suitable brush lubricate the area shown with grease.

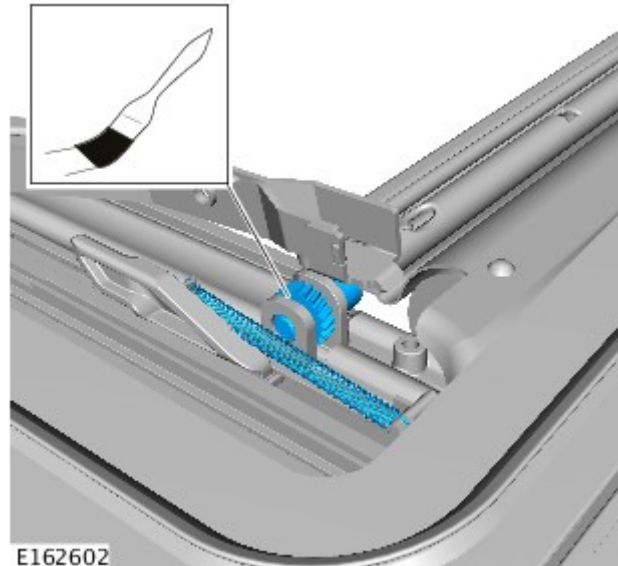

- 12** Using a suitable brush lubricate the contact point with grease.

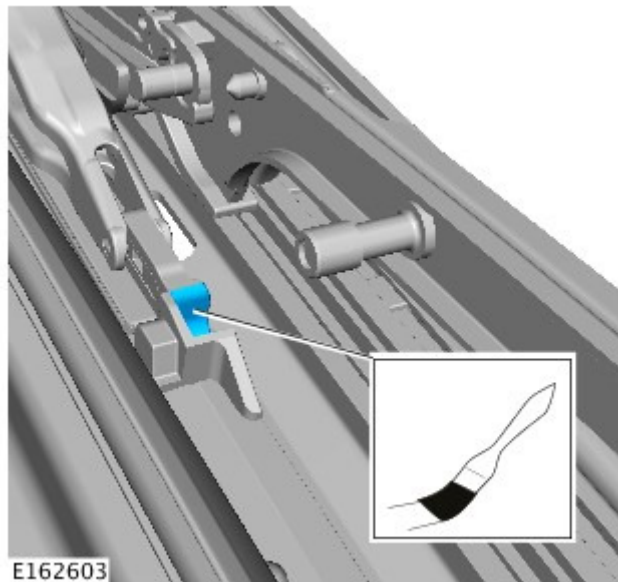

- 13** Repeat the above process for the other side.
- 14** Install the roof opening panel glass (see TOPIx Workshop Manual, section 507-17).
- 15** Carry out roof opening panel alignment procedure (see TOPIx Workshop Manual, section 507-17).
- 16** Carry out motor synchronization procedure (see TOPIx Workshop Manual, section 507-17).