



SERVICE ACTION

Service Action
Number: K117

Subject: Panoramic Roof Creak	Publication No.:	501-K117v3
	Model:	XJ
	Model Year:	2010-2012
	VIN Range:	V00001 to V24464 (SWB) V00001 to V24700 (LWB)
	Date of Issue:	9 th August 2012
	Expiration Date:	28 th February 2014

To:	All UK Authorized Repairers
For the Attention of:	The Managing Director
Copies To:	The Service/After-sales Director/Manager The Parts Director/Manager
Related information:	This Service Action is being re-issued for a change to step 52 in the Workshop Procedure.

RE: Panoramic Roof Creak

Dear Colleagues

In certain circumstances XJ vehicles may experience torsional loads which may cause slight movement in the panoramic roof joints. In some cars this may lead to the generation of noise as the joint slips and sticks.

Action to be taken

Unsold vehicles must be repaired prior to hand-over of the vehicle for retail sale. At the next service opportunity you are requested to inspect the vehicle and where necessary replace the service kit and set opening panel alignment. The workshop procedure is attached as Appendix 1.

Please check DDW to ensure that the vehicle is affected by this Service Action prior to undertaking any rework action. DDW will be updated to reflect only those vehicles affected.

At the time of confirming a booking for vehicle repair, please ensure that all outstanding Field Service Actions are identified to ensure the correct parts are available and adequate workshop time is allocated for repairs to be completed at one visit.

Parts Information

If required the relevant parts from table 1 should be ordered through Jaguar Parts Operations in the normal manner.

Table 1

Description	Part Number	Quantity	% of vehicles requiring this part*
Service kit	C2D23230	1	100
Spacer	C2D23471	1	100

*** - when ordering parts, please order the expected percentage failure rate of parts identified only**

Warranty Information

Table 2 – SROs

Description	SRO	Time
Replace service kit and set opening panel alignment	76.95.89	1.9
Drive in/drive out	10.10.10	0.1

Warranty claims should be submitted quoting program code **K117**, together with the relevant option code from Table 3 of this Service Action. This will result in payment of the stated time. As option codes are used, there is no requirement for you to enter parts or SRO information; these are repeated here for information only.

The option that allows for the drive in/drive out allowance can only be claimed if the vehicle is brought back into the workshop for this action alone to be undertaken.

Table 3

Program Code	Option	Description	SRO	Time	Part Number	Qty
K117	G	Replace service kit and set opening panel alignment	76.95.89	1.9	C2D23230	1
					C2D23471	1
K117	H	Replace service kit and set opening panel alignment	76.95.89	1.9	C2D23230	1
		Drive in/drive out	10.10.10	0.1	C2D23471	1

Warranty claims should be submitted in accordance with the current Jaguar Warranty Policy and Procedures Manual and its amendments, unless stated otherwise in this Service Action.

Yours faithfully



Peter Cockle
 Technical Director – Global Customer Service

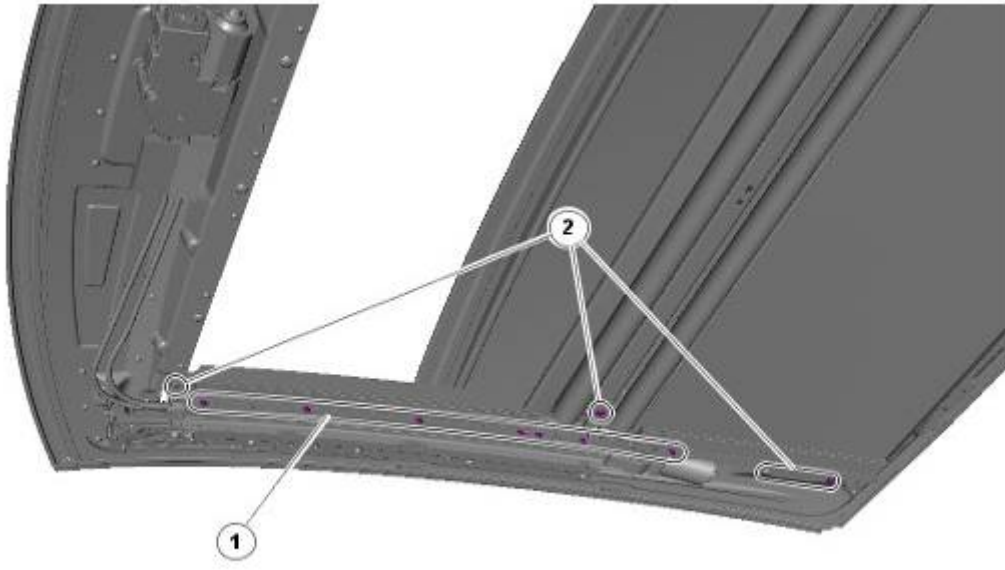


Attached: Appendix 1 – Workshop Procedure

Appendix 1 – Workshop Procedure

CAUTION:  Make sure the vehicle is on a flat level surface.

CAUTION:  Make sure the removed Torx bolts are replaced with encapsulated Torx bolts supplied.

NOTE: All vehicles require 10 Torx bolts, 4 nuts and 14 washers, (there will be surplus parts included in the kit supplied). The Long Wheel Base (LWB) derivatives also require 2 adhesive pads.

Item	Description
	 <p style="text-align: center;">Fig. 1</p>
1	<p>NOTE: RH side shown, LH side similar. NOTE: LWB shown, SWB similar.</p> <p>Note the fixings affected by this re-work (see Fig.1).</p> <ul style="list-style-type: none"> • Fixings required to be rigid (see 1 in Fig.1). • Fixings required to be free to slip (see 2 in Fig.1).
2	<p>CAUTION:  Before starting the Workshop Procedure, protect the complete interior of the car from damage, staining or dirt. Make sure suitable clean gloves are worn especially when handling the headliner, blinds etc.</p> <p>CAUTION:  Make sure no damage is caused to the headliner clips when removing the headlining.</p> <p>Fully open the roof opening panel.</p> <ul style="list-style-type: none"> • Carry out steps 4 to 6, and 9 to 15 from the Headliner procedure (see TOPIx section 501-05). • Remove both C-Pillar Trim Panels (see TOPIx section 501-05)










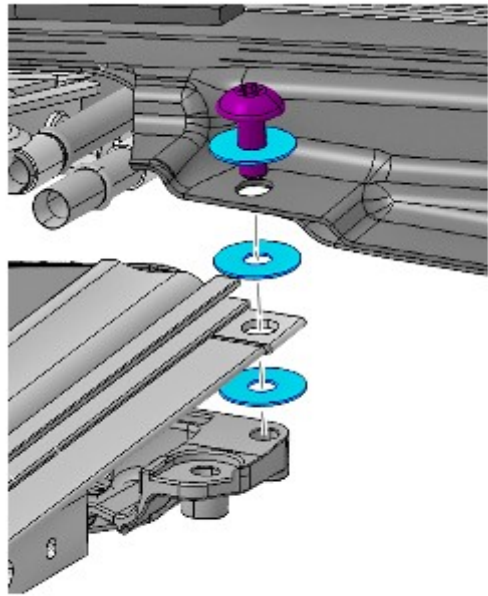
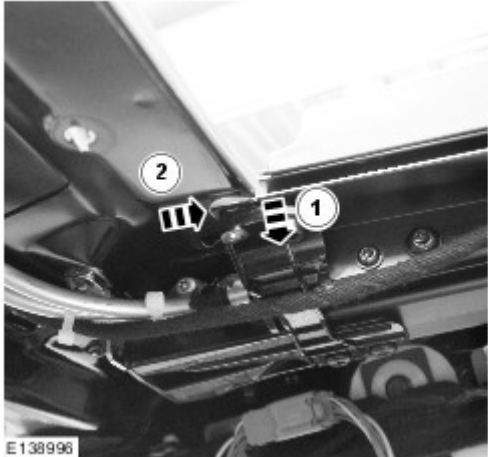
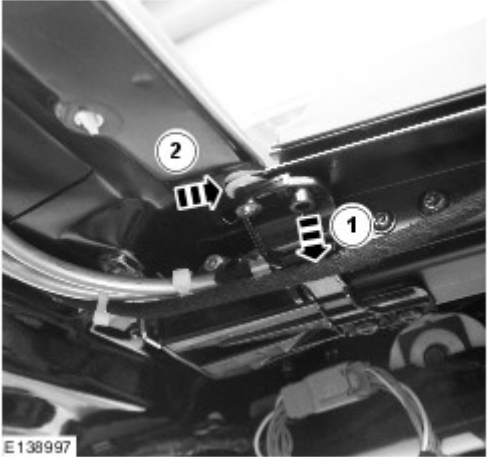

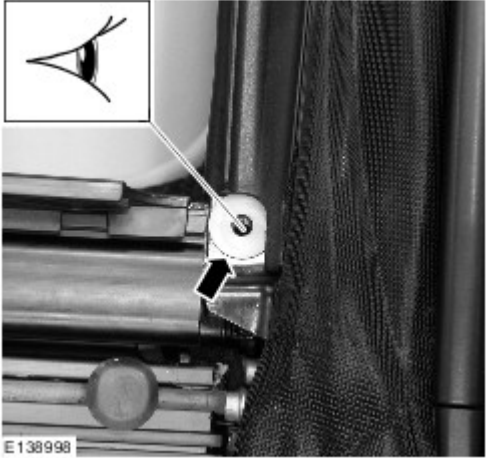



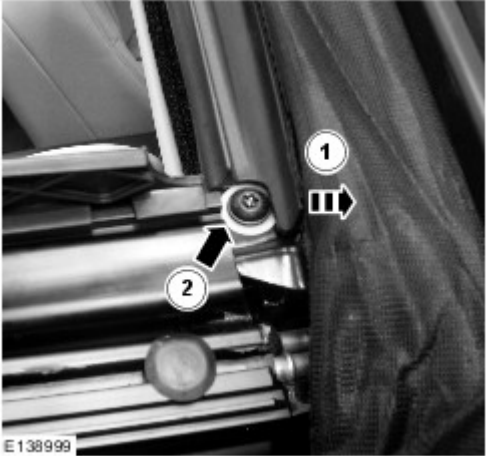




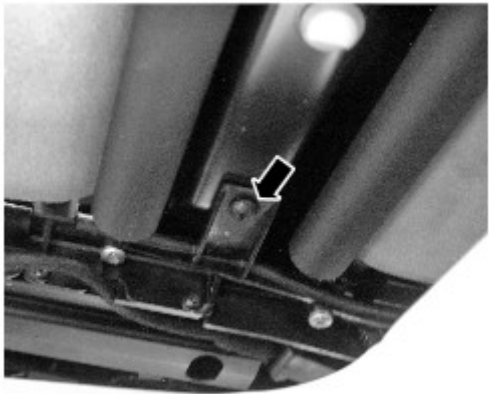

<p>3</p>	<p>CAUTION:  Make sure the headlining is fully supported, and that the harnesses are not damaged during re-positioning.</p> <p>With the aid of another technician carry out steps 17 to 20 from the Headliner procedure (see TOPIx section 501-05).</p> <ul style="list-style-type: none"> • Re-position the front seats in to the fully forward position, fully lowered, with the seat back in the fully upright position and the head rests in the fully lowered position. 	
<p>4</p>	<p>CAUTION:  The locating peg component can be released during this procedure, make sure that pressure is applied to the component to prevent this.</p> <p>CAUTION:  Note the fitted position of the wind deflector net, spring and locating peg component prior to removal.</p> <p>Release the wind deflector (see Fig. 2).</p> <ul style="list-style-type: none"> • Open the roof opening panel glass to the fully open position. • Apply gentle pressure to the locating peg component. • Using a suitable tool release the wind deflector arm. • Repeat the process to the other side of the vehicle. 	 <p>E138993</p>
<p>5</p>	<p>CAUTION:  Make sure that the locating peg component is correctly installed, failure to follow this instruction may result in damage to the vehicle.</p> <p>If required, install the locating peg component (see Fig. 3).</p> <ul style="list-style-type: none"> • Repeat this process to the other side of the vehicle if required. 	 <p>E138994</p>
		<p>Fig. 3</p>


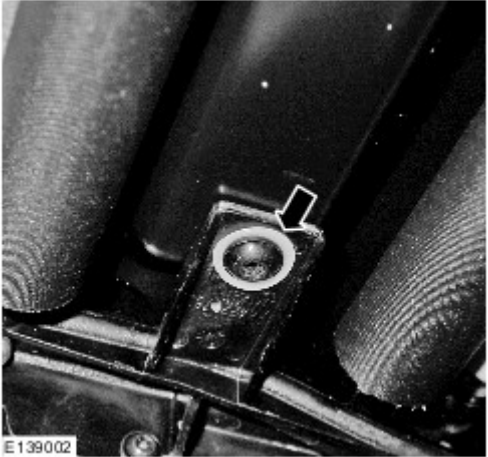




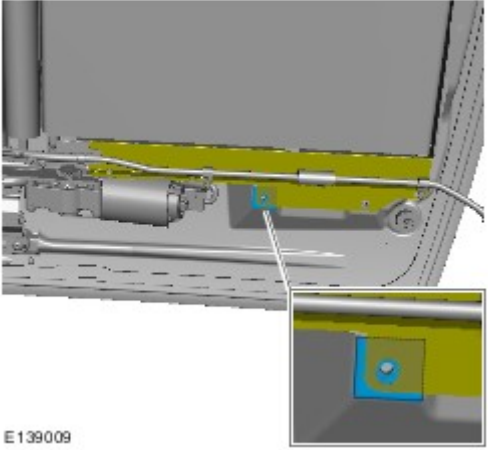
Fig. 2

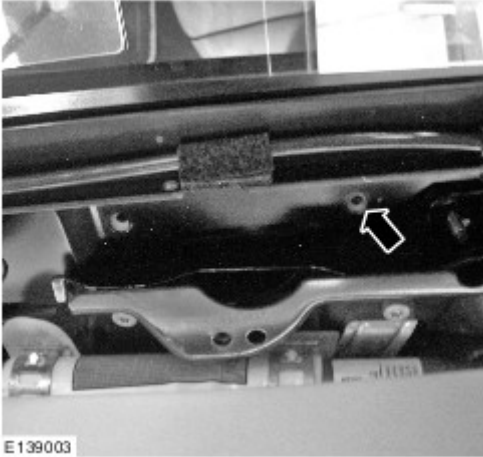

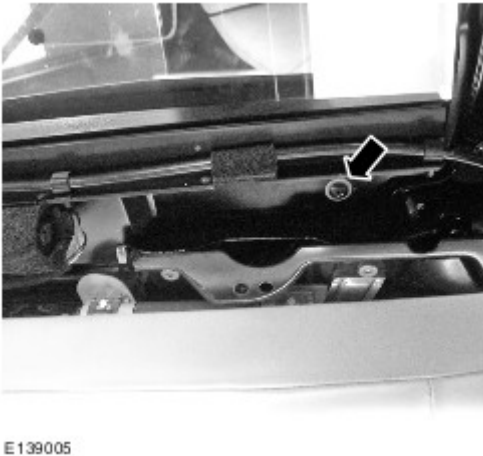


Fig. 3

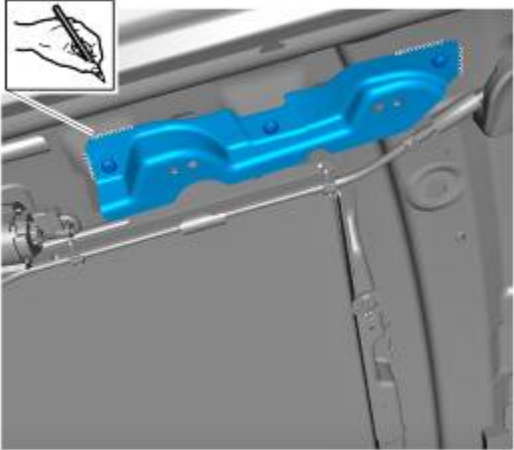




<p>6</p>	<p>CAUTION:  Make sure that the inner sight shield is not disturbed during this procedure.</p> <p>CAUTION:  Make sure the casting thread is clean and free from burrs.</p> <p>Remove and discard the Torx bolt (see Fig. 4).</p> <ul style="list-style-type: none"> • Apply gentle pressure to the trim to aid removal (see 1 in Fig. 4). • Remove and discard the Torx bolt (see 2 in Fig. 4). • Remove any residual traces of locking adhesive from the casting threads and the fixing mating faces. 	
		<p>Fig. 4</p>
<p>7</p>	<p>Note the position of the washers within the roof assembly (see Fig. 5).</p>	
		<p>Fig. 5</p>
<p>8</p>	<p>Install the middle washer (see Fig. 6).</p> <ul style="list-style-type: none"> • If required, apply gentle downwards pressure to create a sufficient gap between the mating surfaces (see 1 in Fig. 6). • Slide the washer in from the front of the vehicle until it is aligned with the hole (see 2 in Fig. 6). 	
		<p>Fig. 6</p>

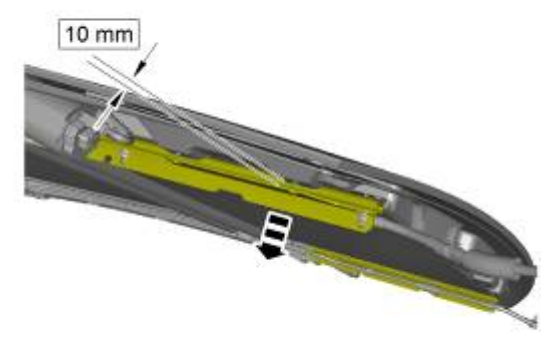

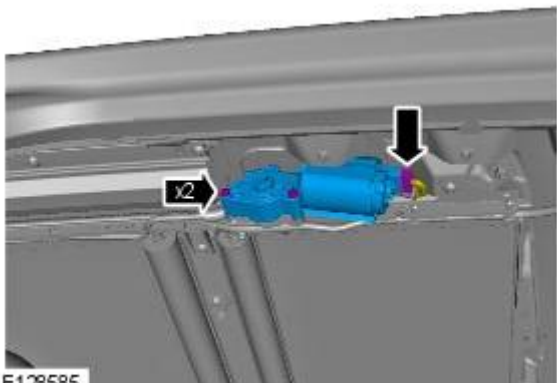

<p>9</p>	<p>Install the lower washer (see Fig. 7).</p> <ul style="list-style-type: none"> Using a suitable tool apply a gentle pressure to create a sufficient gap between the mating surfaces (see 1 in Fig. 7). Slide the washer in from the front of the vehicle until it is aligned with the hole (see 2 in Fig. 7). 	
		<p>Fig. 7</p>
<p>10</p>	<p>CAUTION:  Make sure that the 3 washers are correctly aligned with the hole.</p> <p>Install the upper washer (see Fig. 8).</p>	
		<p>Fig. 8</p>
<p>11</p>	<p>CAUTION:  Make sure that the Torx bolt is not cross threaded during installation.</p> <p>CAUTION:  Make sure that the Torx bolt is tightened by hand, do not use air tools.</p> <p>CAUTION:  Make sure the casting thread is clean and free from burrs.</p> <p>Install the new Torx bolt (see Fig. 9).</p> <ul style="list-style-type: none"> If required, apply gentle pressure to the trim (see 1 in Fig. 9). Tighten the Torx bolt to 4 Nm (see 2 in Fig. 9). If the upper washer is free to rotate after the fixing is tightened, progressively tighten the Torx bolt until the upper washer is fully clamped. Tighten the Torx bolt a further 90 degrees. 	
		<p>Fig. 9</p>

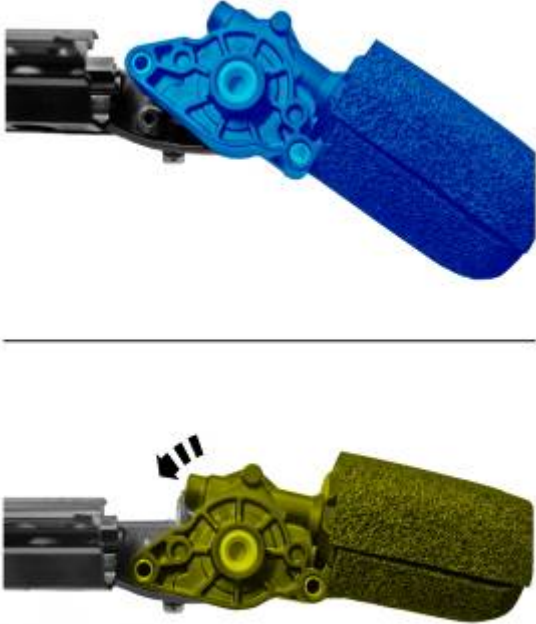
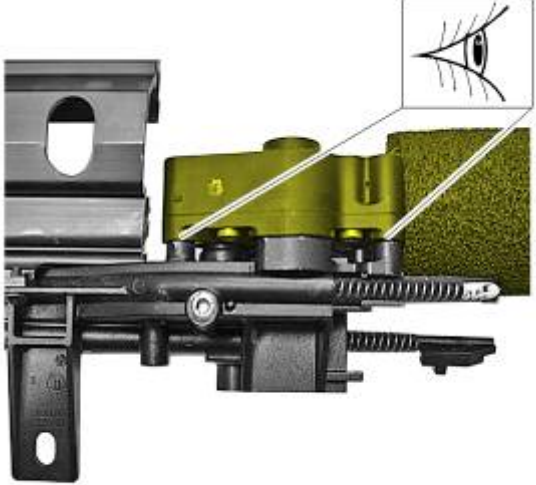
12	Repeat steps 6 to 11 to the other side.	
13	<p>CAUTION:  Make sure the locating peg component is correctly located.</p> <p>CAUTION:  Make sure the spring is correctly located.</p> <p>Install the wind deflector.</p> <ul style="list-style-type: none"> Carefully install the wind deflector arm to the locating peg component. Repeat to the other side. If required, adjust the wind deflector net. 	
14	<p>CAUTION:  On the first operation there may be an audible click, this is normal.</p> <p>Manually check the operation of the wind deflector.</p> <ul style="list-style-type: none"> Press the wind deflector fully down 3 times. 	
The following steps are for the RH side only		
15	<p>CAUTION:  Make sure the thread is clean and free from burrs.</p> <p>NOTE: RH side only</p> <p>Remove and discard the Torx bolt (see Fig. 10).</p>	 <p>E139000</p>
		Fig. 10
16	<p>NOTE: RH side only</p> <p>Install the upper washer (see Fig. 11).</p> <ul style="list-style-type: none"> Slide the washer in between the mating faces until it is aligned with the hole. 	 <p>E139001</p>
		Fig. 11


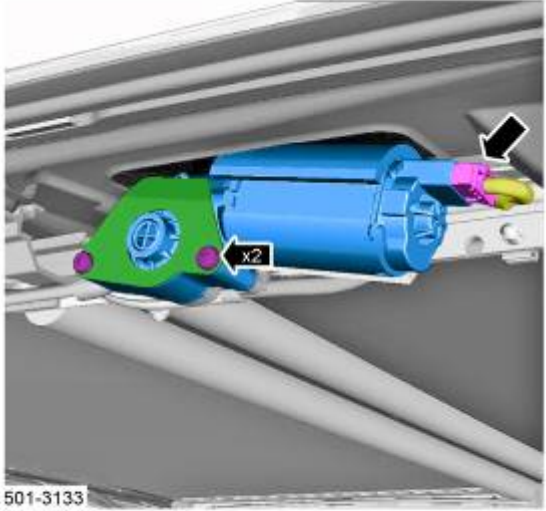

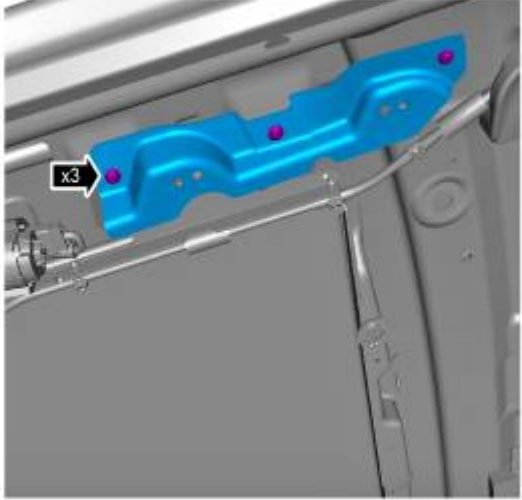

<p>17</p>	<p>CAUTION:  Make sure the thread is clean and free from burrs.</p> <p>NOTE: RH side only.</p> <p>Install the new Torx bolt (see Fig. 12).</p> <ul style="list-style-type: none"> • Install a washer to the bolt. • Tighten the Torx bolt to 4 Nm. 	
		<p>Fig. 12</p>
<p>18</p>	<p>CAUTION:  Make sure the lateral position of the rail is marked before removing the fixings.</p> <p>CAUTION:  Make sure the threads are clean and free from burrs.</p> <p>NOTE: Long Wheel Base (LWB) has two fixings and the Standard Wheel Base (SWB) has one fixing.</p> <p>NOTE: LWB shown, SWB is similar.</p> <p>NOTE: RH side only.</p> <p>Using a suitable marker, mark the lateral position of the rail (see Fig. 13).</p> <ul style="list-style-type: none"> • Remove and discard the Torx bolt(s). 	
		<p>Fig. 13</p>
<p>19</p>	<p>CAUTION:  Make sure that the adhesive foam pad is positioned directly above the front fixing hole.</p> <p>NOTE: LWB only.</p> <p>NOTE: RH side only.</p> <p>Install the adhesive foam pad between the mating faces of the discarded front fixing hole (see Fig. 14).</p>	
		<p>Fig. 14</p>


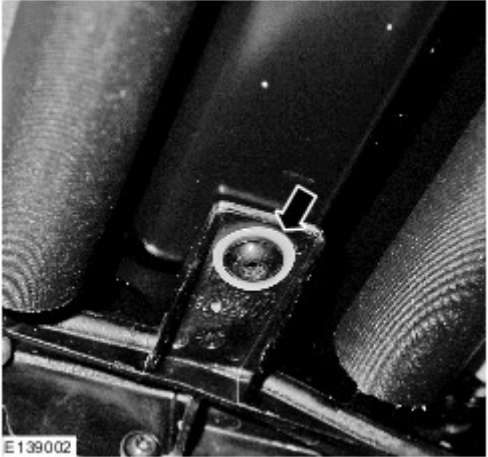

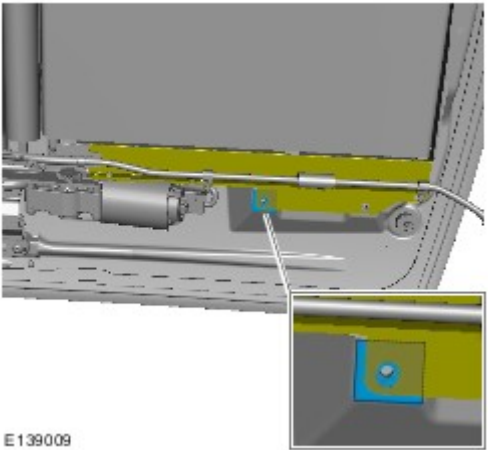
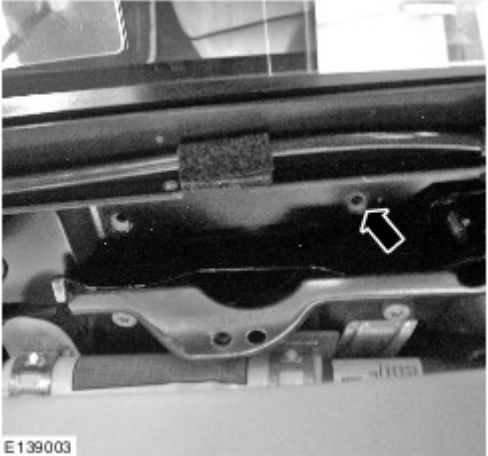
<p>20</p>	<p>NOTE: Do not install a fixing to the front hole on LWB vehicles. NOTE: RH side only.</p> <p>Install the upper washer (see Fig. 15).</p> <ul style="list-style-type: none"> Slide the washer in between the mating faces until it is aligned with the hole. 	
		<p>Fig. 15</p>
<p>21</p>	<p>CAUTION:  Make sure the threads are clean and free from burrs. NOTE: RH side only.</p> <p>Install the new Torx bolt (see Fig. 16).</p> <ul style="list-style-type: none"> Install a washer to the bolt. Align the rail to the marked lateral position. Tighten the Torx bolt to 4 Nm. 	
		<p>Fig. 16</p>
<p>The following steps are for the LH side only</p>		
<p>22</p>	<p>CAUTION:  Make sure the thread is clean and free from burrs. NOTE: LH side only. NOTE: RH side shown, LH similar.</p> <p>Remove and discard the Torx bolt (see Fig. 17).</p>	
		<p>Fig. 17</p>





<p>23</p>	<p>NOTE: LH side only.</p> <p>Using a suitable marker, mark the position of the grab handle bracket (see Fig. 18).</p>	 <p>5013103</p>
		<p>Fig. 18</p>
<p>24</p>	<p>NOTE: LH side only.</p> <p>Remove the grab handle bracket (see Fig. 19).</p> <ul style="list-style-type: none"> Remove the 3 Torx bolts 	 <p>5013104</p>
		<p>Fig. 19</p>
<p>25</p>	<p>CAUTION:  Make sure the lateral position of the rail is marked before removing the fixings.</p> <p>CAUTION:  Make sure the threads are clean and free from burrs.</p> <p>NOTE: Long Wheel Base (LWB) has two fixings and the Standard Wheel Base (SWB) has one fixing.</p> <p>NOTE: LWB shown, SWB is similar.</p> <p>NOTE: LH side only.</p> <p>NOTE: RH side shown, LH similar.</p> <p>Using a suitable marker, mark the lateral position of the rail (see Fig. 20).</p> <p>Remove and discard the Torx bolt(s).</p>	 <p>E139004</p>
		<p>Fig. 20</p>

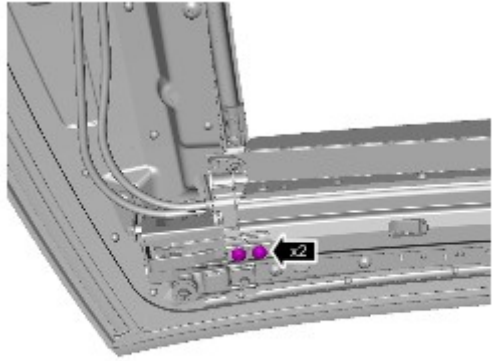


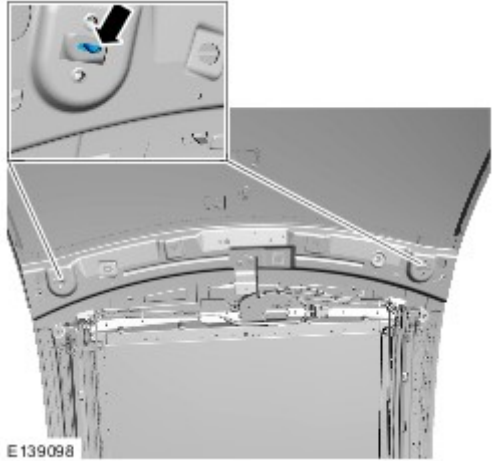
<p>26</p>	<p>NOTE: LH side only. Lower the rear of the guide Rail by 10mm (see Fig. 21).</p>	 <p>501 3101</p>
<p style="text-align: right;">Fig. 21</p>		
<p>27</p>	<p>CAUTION:  Note the fitted position of the harness. NOTE: LH side only. Remove the glass panel opening blind motor (see Fig. 22). <ul style="list-style-type: none"> • Remove the 2 Torx bolts. • Disconnect the electrical connector. </p>	 <p>E128585</p>
<p style="text-align: right;">Fig. 22</p>		
<p>28</p>	<p>NOTE: The spacer will be correctly seated when an audible click is heard. If it does not seat fully it may cause damage to the fixing threads etc when the motor is offered back into position. NOTE: LH side only. Install the spacer (see Fig. 23).</p>	 <p>501 3099</p>
<p style="text-align: right;">Fig. 23</p>		


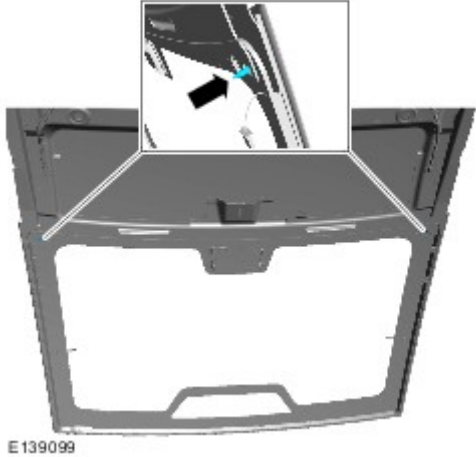
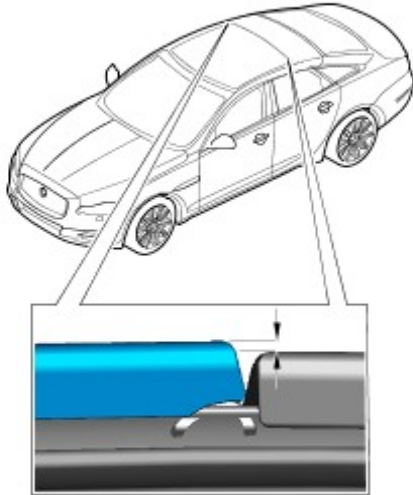
<p>29</p>	<p>NOTE: LH side only. Install the glass opening panel blind motor (see Fig. 24).</p>	 <p>501 3102</p>
		<p>Fig. 24</p>
<p>30</p>	<p>NOTE: LH side only. Make sure that the glass opening panel blind motor is correctly located in to the casting (see Fig. 25).</p>	 <p>501 3100</p>
		<p>Fig. 25</p>


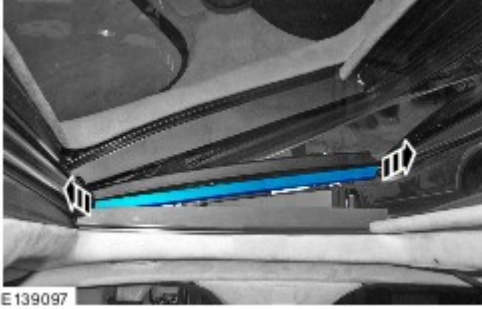

<p>31</p>	<p>CAUTION:  Make sure the harness is located in the original position.</p> <p>NOTE: LH side only.</p> <p>Secure the glass opening panel blind motor (see Fig. 26).</p> <ul style="list-style-type: none"> • Install the support bracket. • Install the Torx bolts and tighten to 6 Nm. • Connect the electrical connector. 	
		<p>Fig. 26</p>
<p>32</p>	<p>CAUTION:  Make sure the grab handle bracket is located in the original position.</p> <p>NOTE: LH side only.</p> <p>Install the grab handle bracket (see Fig. 27).</p> <ul style="list-style-type: none"> • Tighten the Torx bolts to 6 Nm. 	
		<p>Fig. 27</p>
<p>33</p>	<p>NOTE: LH side only.</p> <p>NOTE: RH side shown, LH similar.</p> <p>Install the upper washer (see Fig. 28).</p> <ul style="list-style-type: none"> • Slide the washer in between the mating faces until it is aligned with the hole. 	
		<p>Fig. 28</p>

<p>34</p>	<p>CAUTION:  Make sure the thread is clean and free from burrs.</p> <p>NOTE: LH side only.</p> <p>Install the new Torx bolt (see Fig. 29).</p> <ul style="list-style-type: none"> • Install a washer to the bolt. • Tighten the Torx bolt to 4 Nm. 	
		<p>Fig. 29</p>
<p>35</p>	<p>CAUTION:  Make sure that the adhesive foam pad is positioned directly above the front fixing hole.</p> <p>NOTE: LWB only.</p> <p>NOTE: LH side only.</p> <p>NOTE: RH side shown, LH similar.</p> <p>Install the adhesive foam pad between the mating faces of the discarded front fixing hole (see Fig. 30).</p>	
		<p>Fig. 30</p>
<p>36</p>	<p>NOTE: Do not install a fixing to the front hole on LWB vehicles.</p> <p>NOTE: LH side only.</p> <p>NOTE: RH side shown, LH similar.</p> <p>Install the upper washer (see Fig. 31). Slide the washer in between the mating faces until it is aligned with the hole.</p>	
		<p>Fig. 31</p>

<p>37</p>	<p>CAUTION:  Make sure the threads are clean and free from burrs.</p> <p>NOTE: LH side only.</p> <p>NOTE: RH side shown, LH similar.</p> <p>Install the new Torx bolt (see Fig. 32).</p> <ul style="list-style-type: none"> • Install a washer to the bolt. • Align the rail to the marked lateral position. • Tighten the Torx bolt to 4 Nm. 	 <p>E139005</p>
<p>Fig. 32</p>		
<p>The steps below apply to both sides of the vehicle</p>		
<p>38</p>	<p>Install the Torx bolt and nut (see Fig. 33).</p> <ul style="list-style-type: none"> • Tighten to 6 Nm. • Repeat to the other side. 	 <p>E139006</p>
<p>Fig. 33</p>		
<p>39</p>	<p>NOTE: Harness shown re-positioned for clarity, make sure the harness is correctly located in to the rail.</p> <p>Install the Torx bolt and nut (see Fig. 34).</p> <ul style="list-style-type: none"> • Tighten to 6 Nm. • Repeat to the other side. 	 <p>E139007</p>
<p>Fig. 34</p>		

<p>40</p>	<p>Tighten to 2 Torx bolts to 6 Nm (see Fig. 35).</p>	 <p>E139008</p>
		<p>Fig. 35</p>
 <p>E139095</p>		
<p>Fig. 36</p>		
<p>41</p>	<p>Make sure that the seven M4 side rail Torx bolts are tighten to 3 Nm (see Fig. 36).</p>	
<p>42</p>	<p>CAUTION:  Make sure when snapping off the alignment pegs that they do not protrude through the slot in the body as this can cause a noise.</p> <p>NOTE: Apply a small amount of grease to the inside of the socket to prevent the broken peg remaining in the vehicle.</p> <p>If present, remove the front windshield locating pegs (see Fig. 37).</p> <ul style="list-style-type: none"> Using a suitable socket (5.5mm deep) and extension bar, snap off the pegs. 	 <p>E139098</p>
		<p>Fig. 37</p>

<p>43</p>	<p>CAUTION:  Make sure when snapping off the alignment pegs that they do not protrude through the slot in the body as this can cause a noise.</p> <p>If present, repeat the above step to the rear windshield locating pegs (see Fig. 38).</p>	 <p>E 139099</p>
		<p>Fig. 38</p>
<p>44</p>	<p>Check the operation of the one-touch function on the roof opening panel glass, and both blinds.</p> <ul style="list-style-type: none"> • Fully close the roof opening panel glass. • Check the one touch function. • If the operation of the roof opening panel glass is not normal, check the wind deflector alignment and locating peg position (see step 13 of this Workshop Procedure). 	
<p>45</p>	<p>To install the headliner, reverse steps 2 and 3.</p>	
<p>46</p>	<p>Make sure that the rear of the opening glass panel is set to the profile of flush or up to +1mm proud at the rear outer corners (see Fig. 39).</p> <ul style="list-style-type: none"> • If the roof opening panel glass is outside the above specification, adjust the roof opening panel glass by relaxing the centre and rear fixings. 	 <p>E 139942</p>
		<p>Fig. 39</p>

<p>47</p>	<p>CAUTION:  Note the fitted position and gap between the top of the shield and the roof opening panel.</p> <p>If required, adjust the rear fixings to achieve the above specification (see Fig. 40).</p> <ul style="list-style-type: none"> • Position the roof opening panel glass to the tilt position. • Remove the outer sight shield. 	
		<p>Fig. 40</p>
<p>48</p>	<p>Adjust the roof opening panel glass (see Fig. 41).</p> <ul style="list-style-type: none"> • Release the 2 Torx bolts. • Allow the roof opening panel glass to settle. • Tighten the Torx bolts to 7 Nm. 	
		<p>Fig. 41</p>
<p>49</p>	<p>Close the roof opening panel glass and check that the specification has been achieved.</p> <ul style="list-style-type: none"> • If the specification has not been achieved, repeat steps 47 and 48 to achieve the correct alignment of the roof opening panel. 	
<p>50</p>	<p>Install the outer sight shield.</p>	
<p>51</p>	<p>NOTE: Make sure that the height of the rear edge of the roof opening panel glass is the same on both sides of the vehicle.</p> <p>If required, repeat steps 46 to 50 to the other side.</p>	
<p>52</p>	<p>Road test vehicle to make sure that there are no roof noise concerns present.</p> <ul style="list-style-type: none"> • If no roof noise concerns are present, the vehicle repair is now complete. • If a noise concern is present, continue the road test with the roof opening panel glass in the vent position. • If the noise is not present with the roof opening panel glass in vent position, re-adjust the roof opening panel glass to 1 mm above the leading edge of the rear fixed glass panel. • Repeat the road test after re-adjusting the roof opening panel glass and make sure the noise concern is no longer present. <p>NOTE: Any other repairs carried out as a result of the D&T diagnostics must be claimed as a separate Warranty Claim.</p> <ul style="list-style-type: none"> • If further noise concerns are present please review the D&T within TOPIx section 501-17. 	