



 **CAUTION:** When using a floor jack to jack up the rear of the vehicle, the jack head must be aimed at the NVH bar securing bolts to avoid fuel tank damage or body damage.

 **CAUTION:** When using a floor jack, a cushioned pad must be utilized to avoid body damage.

 **CAUTION:** When using axle stands, a cushioned pad must be utilized to avoid damage to the body or rear subframe assembly.

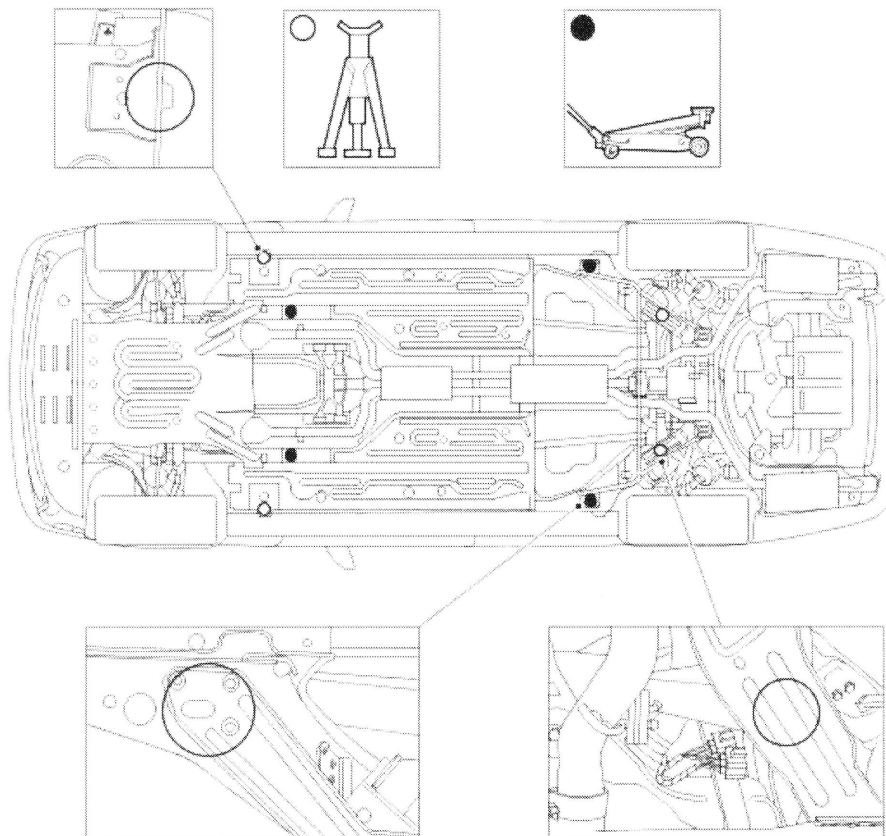

E37355

Vehicle Recovery

NOTE:

Prior to vehicle recovery, make sure the vehicle keys are available and the security system is disarmed.