



Technical Service Bulletin

No.B501-13
17 February 2005

Subject/Concern: Water Ingress Roof Opening Panel Area

Models:

XJ Range | North America Only | North America Only VIN-range: G00442-G38526

Markets: All

Section: 501-25D

Summary:

This Technical Bulletin has been issued to address customer concerns of water ingress from the roof opening panel area, staining the head lining, and with the possibility of the instrument pack warning light illuminating.

Cause: The roof opening panel rear drain tubes may be restricted and will not allow water to drain away. This may lead to water spilling onto the head lining and water may also run down the D-pillar area and accumulate in the rear seat pan, and lead to potential corrosion to connectors FP002 and FP006.

Action: Should a customer express concern, check that the roof opening panel drain tubes are draining correctly, and reposition the drain tubes if required. Follow the Service Instruction outlined below.

Parts Required:

Description	Part Number	Quantity
N/A		N/A

Labour Time:

Operation Description	Operation No.	Time
Check water drain and reposition drain tube - one side only (without removing seats)	76 94 69/04	0.4 hours
Check water drain and reposition drain tube - both sides (without removing seats)	76 94 69/05	0.6 hours

Repair/Claim Coding:

Causal Part:	C2C 19603
ACES Condition Code:	N/A
Defect Code:	N/A

Service Instruction

- 1 . Drive the vehicle onto a suitable raised surface so the front wheels are approximately 75mm (3in) higher than the rear wheels.



- 2 . Open the roof opening panel and ensure the ignition is turned 'OFF'.



CAUTION: When pouring water into the channel, make sure it does not overflow and run over the roof opening panel mechanism into the vehicle cabin.

- 3 . Using a suitable container/bottle slowly pour water into the roof opening panel drainage channel.

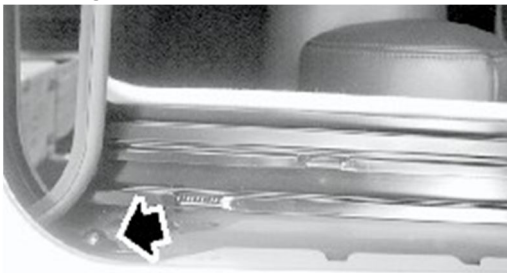

- 4 . With assistance, look for water flowing onto the floor from the drain tubes located behind the rear wheels.

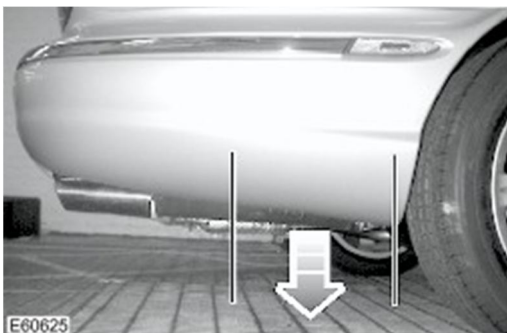

- 5 . Repeat step 3 for the opposite side of the roof opening panel.

If the water drains from both drain tubes, follow Technical Service Bulletin B501-07 to identify the source of the water ingress. If the water does not drain from both drain tubes, carry on from step 6.

- 6 . Disconnect the battery (see Global Technical Reference GTR Workshop Manual, section: 414-01).

- 7 . Remove the high mounted stoplamp (see Global Technical Reference GTR Workshop Manual, section: 417-01).
- 8 . Place suitable protective material on the rear parcel shelf.
- 9 . Locally detach the weather strip from the rear door aperture.



CAUTION: Do not detach the C-pillar upper trim panel retaining strap from the body. Do not detach the rear safety belt.

- 10 . Carefully detach the C-pillar upper trim panel. Slide the retaining strap downwards to detach the strap from the trim panel, and place the trim panel on the rear parcel shelf.

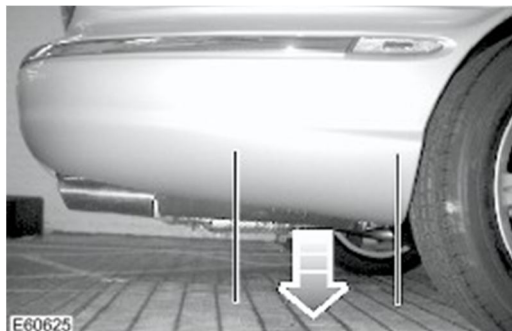

- 11 . **NOTE:** Note the fitted position of the washers prior to removal.

Remove the rear occupant assistance handle.

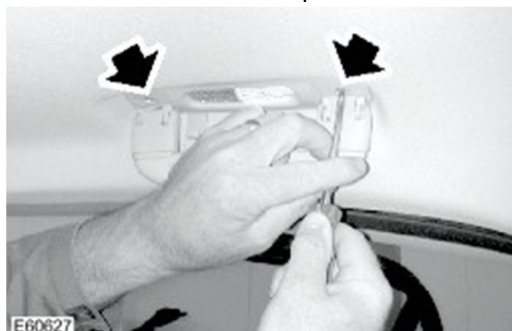

- 12 . Carefully lower the rear corner of the headlining sufficiently to gain access to the drain tube.
- 13 . Remove and discard the adhesive tape securing the drain tube to the roof panel.
- 14 . Reposition the drain tube between the white foam blocks.

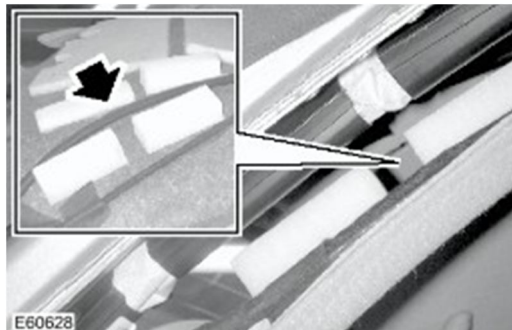

- 15 . Reposition the headlining to the roof panel, ensuring the drain tube remains between the white foam blocks.
- 16 . Position the rear occupant assistance handle to the headlining, ensuring the washers are fitted correctly. Install screws and torque to 1.5Nm (1.11 lbf.ft).

17 . Reposition excess drain tube downwards past parcel shelf edge.



CAUTION: When pouring water into the channel, make sure it does not overflow and run over the roof opening panel mechanism into the vehicle cabin.

18 . Using a suitable container/bottle slowly pour water into the roof opening panel drainage channel.

19 . With assistance, look for water flowing onto the floor from the drain tubes behind the rear wheels.

20 . If water is not flowing from the drain tube, remove the rear occupant assistance handle and carefully lower the rear corner of the headlining sufficiently to gain access to the drain tube. Reposition the drain tube and retest until water flows from the tube. Reposition the headlining to the roof opening panel and reinstall the rear occupant assistance handle.



CAUTION: Ensure the retaining strap is fully located to the C-pillar trim panel.

21 . Install the retaining strap to the C-pillar upper trim panel, install and fully seat the upper C-pillar trim.



22 . Locally install and seat the weather strip to the rear door aperture.

23 . If required carry out steps 9 to 22 for the opposite side of the roof opening panel.

24 . Remove the protective material from the rear parcel shelf.

25 . Install the high mounted stoplamp (see Global Technical Reference GTR Workshop Manual, section: 417-01).



CAUTION: When pouring water into the channel, make sure it does not overflow and run over the roof opening panel mechanism into the vehicle cabin.

26 . Using a suitable container/bottle slowly pour water into the roof opening panel drainage channel.

27 . With assistance, look for water flowing onto the floor from the drain tubes behind the rear wheels.

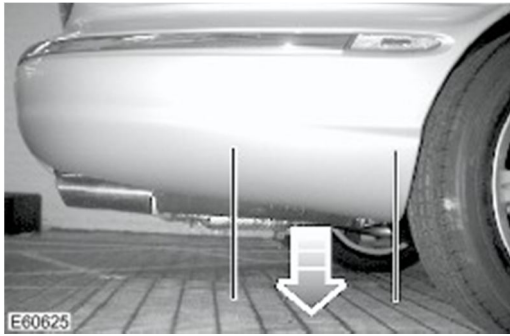

- 28 . Connect the battery (see Global Technical Reference GTR Workshop Manual, section: 414-01).
- 29 . Close the roof opening panel.
- 30 . Close the door.

©2005 Jaguar