

## Contents

Introduction . . . . .	1
PDI Sheets . . . . .	1
Rectification and Warranty . . . . .	1
Showroom Preparation and Valeting . . . . .	1
Preparation . . . . .	2
Vehicle Details . . . . .	2
Vehicle Order Specification . . . . .	2
Checking Battery Voltage . . . . .	3
Battery Isolation Transit Relay . . . . .	3
Effects of Battery Disconnection . . . . .	5
Fitting of Transit Items . . . . .	7
Standard Checks: Fluid Levels and Tyre Pressures . . . . .	9
Recommended Lubricants and Fluids . . . . .	9
Fluid Reservoirs and Dipstick Locations . . . . .	10
Fluid Leaks . . . . .	11
Check/Top-up Engine Oil . . . . .	11
Check/Top-up Power Steering Fluid . . . . .	12
Check/Top-up Brake Fluid . . . . .	12
Check/Top-up Coolant . . . . .	13
Check/Top-up Windscreen Washer Reservoir . . . . .	14
Tyre Pressures . . . . .	14
Standard Checks: Functional . . . . .	15
Parkbrake Operation . . . . .	15
Windscreen Washer and Wipers . . . . .	15
Exterior Lighting . . . . .	16
Brake and Reversing Lights . . . . .	17
Direction Indicators . . . . .	17
Hazard Warning Light . . . . .	17
Door Mirror Adjustment . . . . .	18
Seat Belts . . . . .	18
Horn . . . . .	18
Road Test . . . . .	19
Pre-Road Test . . . . .	19
On the Open Road . . . . .	19
After Road Test . . . . .	19
Final Preparation . . . . .	24
Brake Disc Transit Protection Bags . . . . .	24
Tyre Pressures . . . . .	24
Removing the Transit Relay . . . . .	24
Airbag warning label (USA/Canada) . . . . .	25
Navigation System (where fitted) . . . . .	26
Removal of KATS Transit Coating . . . . .	28
Valeting . . . . .	29
Owner Literature . . . . .	29



**JAGUAR**

## INTRODUCTION

### CAUTION:

**With the transit relay fitted, the parking brake can only be released by adopting the following procedure:**

- Turn the ignition switch to position II and wait 5 seconds.
- Apply the foot brake and hold.
- Lift the parking brake switch to apply.
- Press the parking switch to release.

**See page 15 for further details on parking brake operation.**

This Pre-Delivery Inspection Manual (PDI) is applicable to the Jaguar XJ model only.

The purpose of the Pre-Delivery Inspection is to ensure that customers receive a vehicle which has been built and prepared to the highest possible standard.

**No vehicle should be put on public display before the Pre-Delivery Inspection (PDI) has been conducted.**

Before starting the PDI, Service Bulletins must be checked for the latest information.

### Note:

Ensure that vehicle body protectors and internal protection covers are available.

## PDI Sheets

PDI Check Sheets are provided with boxes marked '✓' for 'Checked Correct' and 'X' for 'Action Required'.

### Important:

**When marking a box 'X', notes must be made in the 'Comments' column, e.g. 'Engine oil low', 'Oil leak from sump joint', etc.**

## Rectification and Warranty

If simple rectification of a minor fault can be accomplished by the PDI engineer, then this should be done e.g. bulb replacement; tyre pressure adjustment; fluid reservoir top-up; touching-in small chips or blemishes, etc.

Major defects however, serious panel or paint rectification work, must be reported to Jaguar Cars Limited and rectified under strict supervision in Jaguar workshops, within the guidelines of laid down Warranty Policy.

Certain warranty work at PDI may require prior consultation.

Should items be missing, the required parts should be procured through normal channels and costs claimed back via the DDW system under the 'Shortage' claim type.

All missing items should be recorded on the PDI Check Sheet and countersigned by an authorised person.

Claims for rectifying incorrect specification items and/or shortages must be made in accordance with the conditions detailed in Section C of the Warranty Policy and Procedures Manual.

### Note:

Prior authority must be obtained from Jaguar, if the total cost of rectifying all incorrect specifications or all shortages (calculated at warranty reimbursement rates) is £250 or more per vehicle.

Delivery damage is not the responsibility of Jaguar Cars Limited and must not be made the subject of a warranty claim. It is the responsibility of the Dealer to identify any such damage at the time of the new vehicle receipt and to ensure that the full details are recorded on the Delivery Receipt. Claims for rectification of such damage must be directed to the Delivery Company.

Failure to notify the Delivery Company of damage details at the time of vehicle delivery will result in claims for subsequent rectification being rejected.

Warranty claims for damage repairs may only be submitted where Jaguar's responsibility is clearly indicated. Examples falling into this category are paintwork damage during the fitment of trim or outward facing dents on the door skin.

Warranty claims will not be accepted for any damage repaired or identified after the vehicle has been placed into service.

## Showroom Preparation and Valeting

The final preparation of the vehicle for the showroom or customer is of paramount importance. It is essential that the vehicle provides satisfaction to the most discerning customer.

Failure to recognise this fundamental requirement will result in customer dissatisfaction and cause unnecessary work having to be carried out at a later date.

# The XJ: Pre-Delivery Inspection

## PREPARATION

It is recommended that the battery voltage check is carried out before switching the ignition on to move the vehicle or perform the main PDI checks. See below.

## Vehicle Details

Record the following vehicle details on the PDI check sheet:

- Vehicle Identification Number (VIN, see below)
- Engine number (see illustration below)

- Model
- Ignition/door key number
- Paint code
- Trim code
- Radio code

The VIN, paint code, trim code and manufacture date are shown on the vehicle Certification Label which is located on the left-hand front door post.

The VIN is also visible from outside the vehicle, on a plate in the lower left edge of the windscreen.

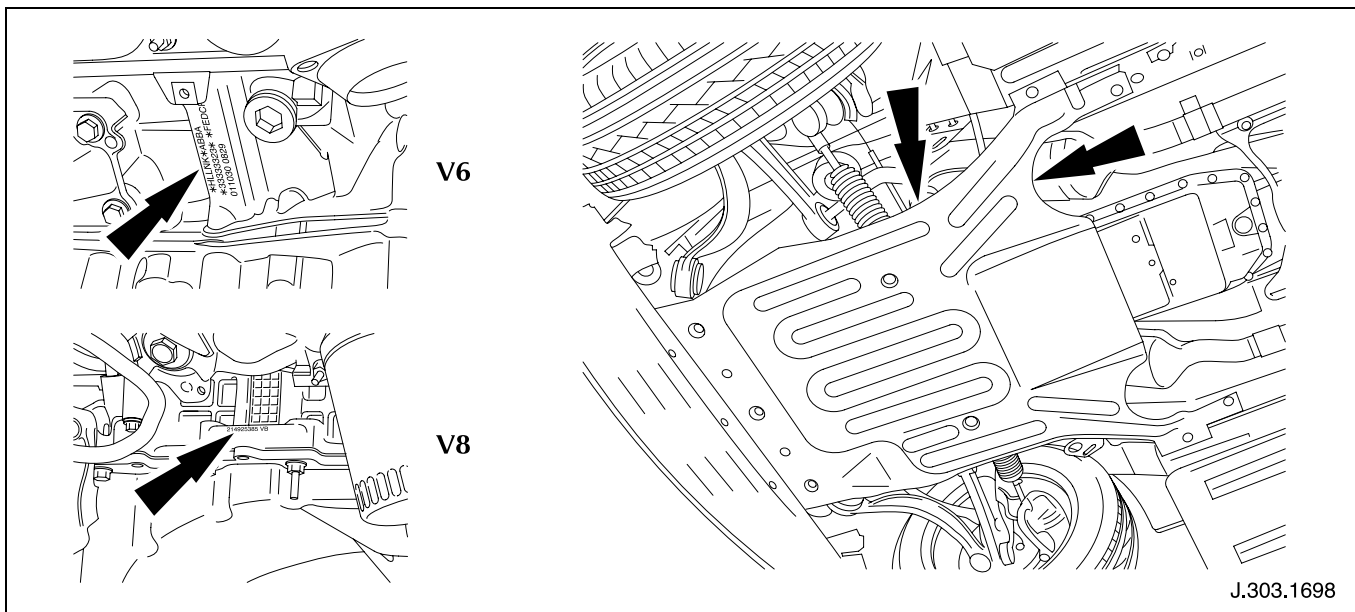

## Vehicle Order Specification

**Check:** The vehicle conforms to the specification and options required including rugs, etc.

## Checking Battery Voltage

To accurately measure the open circuit battery voltage, either of the following preconditions must be observed. It is assumed that the transit relay is fitted.

- Allow 12 hours after the ignition has been switched off before measuring the open circuit voltage.
- Alternatively, switch the ignition on, switch the headlights on for 3 minutes then switch the headlights and ignition off. Wait 10 minutes with the ignition off before measuring the battery voltage.

### Access

Open the luggage compartment and fold the floor panel forward to reveal the battery.



**WARNING:**

**DO NOT SMOKE.**

**AVOID SPARKS, SHORT CIRCUITS OR OTHER SOURCES OF IGNITION.**

**HYDROGEN, WHICH IS HIGHLY EXPLOSIVE, IS EMITTED PARTICULARLY DURING CHARGING.**

**SWITCH OFF CURRENT BEFORE MAKING OR BREAKING ELECTRICAL CONNECTIONS.**

**ALWAYS DISCONNECT THE EARTH TERMINAL FIRST AND RECONNECT IT LAST.**

- 1 Check that the pinch bolts on the battery terminal cables and transit relay are tightened to a torque of **3 – 4 Nm** (10 mm spanner).
- 2 Using a digital multimeter, in Volts mode, connect the red (positive) lead to the battery positive terminal and connect the black (negative) lead to the negative terminal.

**Check:** The meter reading and record the voltage on the PDI check sheet. If the voltmeter reading is below **12.5 Volts** but above 12.45 Volts, recharge the battery.  
If the reading is below 12.45 Volts, fit a replacement battery.

## Battery Isolation Transit Relay

A transit relay is fitted to the battery. This allows the vehicle to be driven when necessary, but isolates the battery from the vehicle during transit and storage preventing the battery becoming discharged.

The Transit Relay (below) is connected between the battery positive post and the battery positive lead. When the ignition is off, the transit relay isolates the positive side of the battery. When the ignition is on, a signal applied via the auxiliary connector (**D**), closing the positive side of the battery circuit.

**The transit relay should remain fitted to the battery until within 24 hours of the handover to the customer, in order to reduce battery drain.**

The PDI checks specified in this document can be carried out with the transit relay fitted and the ignition switched on (where applicable). The ignition should not be left on for extended periods.

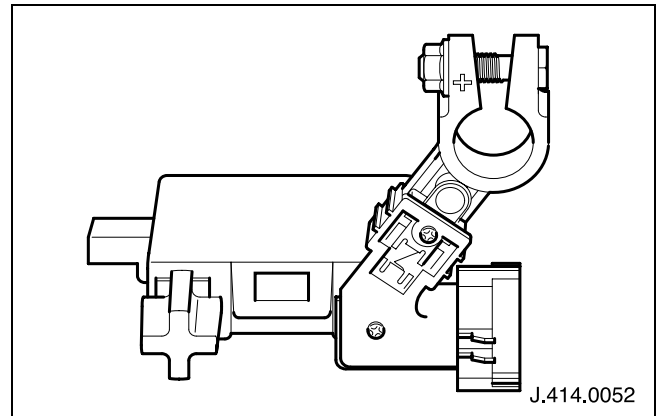

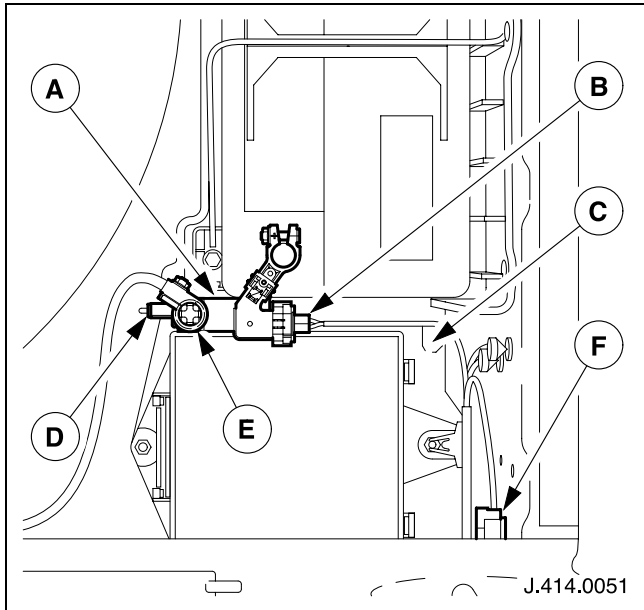

## Transit Relay Removal/Battery Reconnection

To Remove the Transit Relay (A):

- 1 Ensure that the ignition switch is turned off.
- 2 Open the luggage compartment and open the access panel.
- 3 Remove the by-pass feed connector (B) from the transit relay and locate it in the stowage fitting (C) beside the battery.
- 4 Remove the auxiliary connector (D) from the transit relay and locate on the stowage fitting on the battery tray moulding.
- 5 Disconnect the Battery Positive lead (E) from the Transit Relay.
- 6 Disconnect the Transit Relay from the Battery.

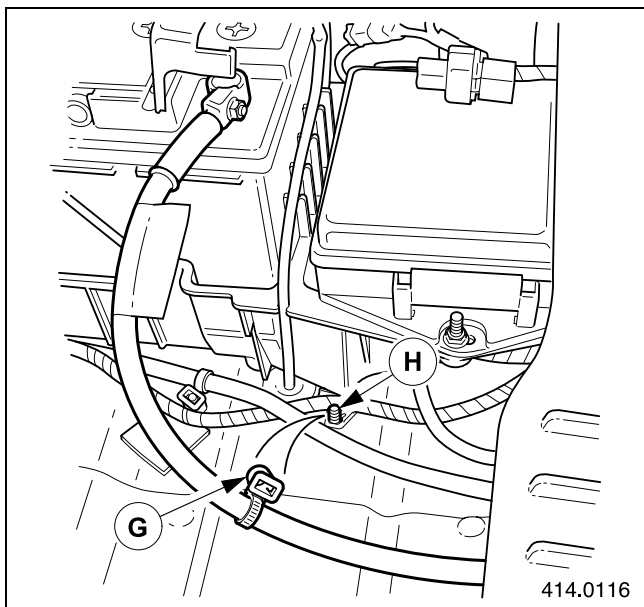

- 7 Refit the Positive lead to the Battery terminal and tighten the pinch bolt to a torque of 3 – 4 Nm.
- 8 Locate the stud fixing (G) on the Positive lead, onto the stud (H) on the bottom of the wheel well, between the spare tyre and the corner of the battery.

### Note:

The Transit Relay must be returned through the Warranty Recovery procedure.

### Air Suspension: Reconnect & Reset

The air suspension is set in 'transportation' mode before leaving the factory. This raises the vehicle to a preset height, with engine on, to allow greater ground clearance during loading onto vehicle transporters. The air suspension electrical connector (F) is supplied disconnected. Reconnect the mating halves of the connector before carrying out the following procedure to reprogram the air suspension into 'customer' mode.

- 1 Fit the World Diagnostic System (WDS) Connector to the vehicle.
- 2 Switch on the WDS and wait 2½ minutes.
- 3 Type in the VIN and tick through the operating warnings.
- 4 When prompted 'Do you want to reconfigure', select 'No'. Confirm that the VIN is correct.
- 5 When prompted 'Do you want to read DTC', select 'No'. The system starts initialising.
- 6 Select 'Vehicle Configuration' tab from the top tool bar. Select 'Set-up and Configuration'. Press the tick and follow the on-screen instructions.
- 7 When prompted, connect the WDS cable to the J1962 connector on the vehicle. Switch On the ignition to position II, 'Loading data' appears on the screen. Tick through the pop-up menus, as appropriate.
- 8 When a list of features that can be reset, appears on the screen, scroll down to 'Air Suspension'. Highlight this text and on the right-hand side of the screen panel, select 'Customer Mode'.
- 9 Press the confirmation button at the top right-hand side of the screen; press the tick at the button right-hand side of the screen.
- 10 On the confirmation panel, select 'Yes' and press the tick. When the program complete panel appears, press the tick.
- 11 Disconnect the WDS connector from the vehicle.

## Effects of Battery Disconnection

If the battery is disconnected, certain electrical functions (see below) must be reset or re-learned.

With the transit relay fitted, switching the ignition off isolates the battery after a delay of approximately 10 – 15 seconds.

### CAUTION:

**Before disconnecting the battery, ensure the ignition is turned off for at least 15 seconds. The battery should never be disconnected with the ignition switched on since this will not allow modules to shut down correctly and will result in fault codes being stored and spurious faults being induced.**

**Ensure a minimum interval of 20 seconds from battery disconnection to battery reconnection.**

**When reconnecting a battery cable, ensure that the operation is carried out in one clean connection to avoid unwanted electrical 'spikes' in the system.**

## Engine Management Adaptations

After a battery disconnection/reconnection, the engine management system loses various adaptive settings (fuelling, etc.) resulting in a slight deterioration in engine/transmission performance such as idle quality and automatic gearshifts. No action is required since the system automatically re-calibrates itself during a normal drive cycle.

## Re-calibrate Throttle Pedal

After battery reconnection, the engine management system must 're-learn' the limits of throttle pedal travel. This is to ensure correct adaptive settings are stored for kickdown operation. Re-programming is done with the ignition switch in position **II** as follows:

- Slowly press the accelerator pedal fully through the kickdown detent to the floor. Release the pedal and repeat the action.

## Security

The alarm system resumes the same state as before the battery was disconnected.

If the alarm was sounding when the battery was disconnected it will sound again when the battery is reconnected. To disarm it press the key transmitter unlock button or insert the ignition key and turn to position **II**.

## Security System Battery Backed Sounder

A security system battery backed sounder is fitted to vehicles in the UK, Belgium, Holland, Israel, Luxembourg, France, Ireland and Malta.

This device will sound the alarm if the vehicle battery is disconnected when the security system is armed.

To prevent the siren sounding during the fitment of the transit relay during production build, the siren feature is disabled from the Dealer Option menu.

Following the final removal of the transit relay, the siren **MUST** be reprogrammed using the World Diagnostic System (WDS) as follows:

- 1 Switch on the WDS and wait 2½ minutes.
- 2 Type in the VIN and tick through the operating warnings.
- 3 When prompted 'Do you want to reconfigure', select 'No'. Confirm that the VIN is correct.
- 4 When prompted 'Do you want to read DTC', select 'No'. The system starts initialising.
- 5 Select 'Vehicle Configuration' tab from the top tool bar. Select 'Dealer Options'. Press the tick.
- 6 When prompted, connect the WDS cable to the J1962 connector on the vehicle. Switch On the ignition to position **II**, 'Loading data' appears on the screen. Tick through the pop-up menus, as appropriate.
- 7 When a list of features that can be reset appears on the screen, scroll down to 'Battery backed sounder'. Highlight this text and on the right-hand side of the screen panel, select 'Enable'.
- 8 Press the confirmation button at the top right-hand side of the screen; press the tick at the button right-hand side of the screen.
- 9 On the confirmation panel, select 'Yes' and press the tick. When the program complete panel appears, press the tick.
- 10 Disconnect the WDS connector from the vehicle.

## Audio Security Code

In some countries, an audio system security code must be re-entered if the battery has been disconnected.

- On systems without the telematics touch screen display, enter the code via the numbered buttons on the radio/cassette panel. A bleep indicates that the code has been entered correctly.
- On systems fitted with the telematics touch screen display, first remove the protective film from the screen. Press the **AUDIO** button at the top left-hand corner of the telematics console and switch the radio/cassette unit on. Enter the security code using the numbered touch screen buttons, followed by the ENTER icon.

## Clock Setting

The analogue clock is adjusted by pressing the (+) and (-) buttons below the dial. Pressing and holding either button will increase the rate of hand movement forwards or backwards, as required.

## Parkbrake

A message 'APPLY PARKBRAKE' will be displayed when the battery is reconnected and ignition is ON. Refer to Parkbrake Operation – 'Note' on page 15.

## Window Anti-trap Feature

Each electrically operated window and the sliding roof has an anti-trap feature on the one-touch close operation. If the upward movement of the window detects an obstacle the anti-trap feature will immediately stop the window closing, then move it downwards for a short distance.

**If the battery is discharged or disconnected either directly or via the transit relay, the window one-touch up/anti-trap function will be cancelled. When the battery is reconnected or recharged the window one-touch up/anti-trap function must be reset. Note that the sliding roof anti-trap function does not require to be reset.**

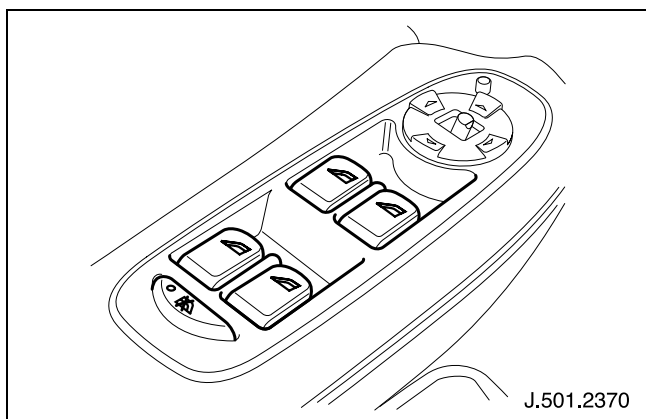

**Window operation** – the window switches are located on the driver's door (switchpack above, RHD version shown) and on each electrically operated window.

To lower a window:

- Press the switch downwards to the first position until the desired position is reached then release.
- For one-touch operation, press the switch briefly to the second position to fully open the window in one movement. Window travel can be stopped at any time by pressing the switch again.

To raise a window:

- Pull the switch upwards to the first position until the desired position is reached, then release. Window travel can be stopped at any time by pressing the switch again.
- For one-touch operation, pull the switch briefly to the second position to fully close the window in one movement. Window travel can be stopped at any time by pressing the switch again.

**One-touch up/anti-trap function reset** – after a battery disconnection/reconnection, the one-touch window close/anti-trap action will not operate (all other window control functions are unaffected).

To reset the one-touch up/anti-trap function:

- 1 Fully close the window, hold the switch in the close position for 2 seconds and then release. Wait for 2 seconds, do not open the window.
- 2 Hold the switch again for a further 2 seconds.
- 3 Confirm the operation by opening the window and then closing it with the one-touch up switch.
- 4 Repeat for the remaining electrically operated windows.

**Ice override** – if, when closing the window, the window stops and reverses, it may be due to a blockage, such as ice, damage in the glass guide or a mislocated seal, causing the anti-trap function to operate. If there are signs of damage or other faults, the problem must be rectified before proceeding with the PDI checks.

If the stoppage is due to icing, the protection function may be overridden:

- After the initial attempt to close the window, operate the close switch a second time.
- When the window has reversed from the blockage, operate the switch (within 10 seconds) until the window stops again (it will not reverse on the third attempt).
- Immediately operate the close switch again. The window will now move up a short distance with increased force to override the blockage.
- Repeat the override action until the window has closed. Each time the window stops, the switch must be operated immediately (within 0.5 seconds) to initiate further override action.

**Motor overload protection** – repeated opening and closing of a window will cause the motor protection system to inhibit all window movement for a short period.



## Fitting of Transit Items

A number of loose items are carried in the trunk during transit and include front and rear towing eye covers, the front grille vane, front number plate plinth and cigar lighters. If a navigation system is fitted, the map DVD is also carried in the trunk and should be loaded during final preparations. See page 26.

## Vehicle Towing Eye

Check that a towing eye, for owner use, is included with the jacking equipment in the trunk. If it is not, retain and stow the towing eye from the rear of the vehicle.

## Front Fixings

Remove the front towing eye. Note it has a left-hand thread and is unscrewed in a clockwise direction. Insert the protective bung into the towing eye fixing hole.

Discard the towing eye as waste material.

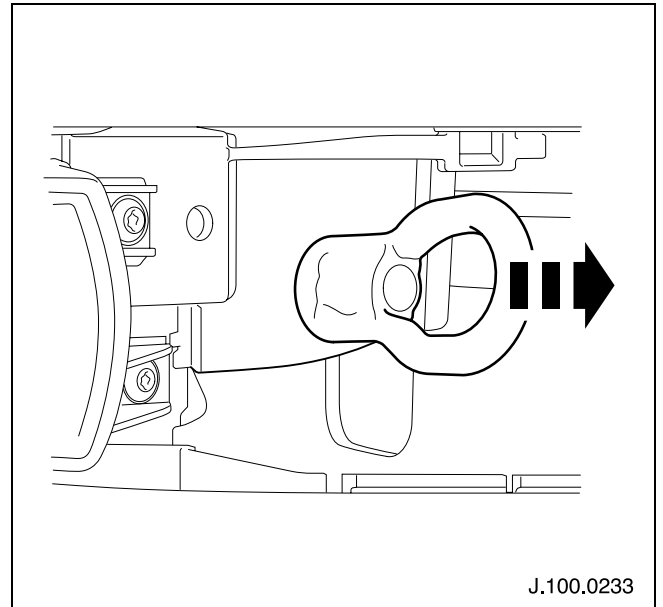

Locate the three lugs at the lower section of the grille vane to the struts in the grille aperture. Pivot up and clip the vane's top lug into position. Secure the vane with the two torx head bolts.

Carefully clip the bumper aperture cover into position. First clip the lower edge to the bumper aperture, pivot up and press the top edge into position.

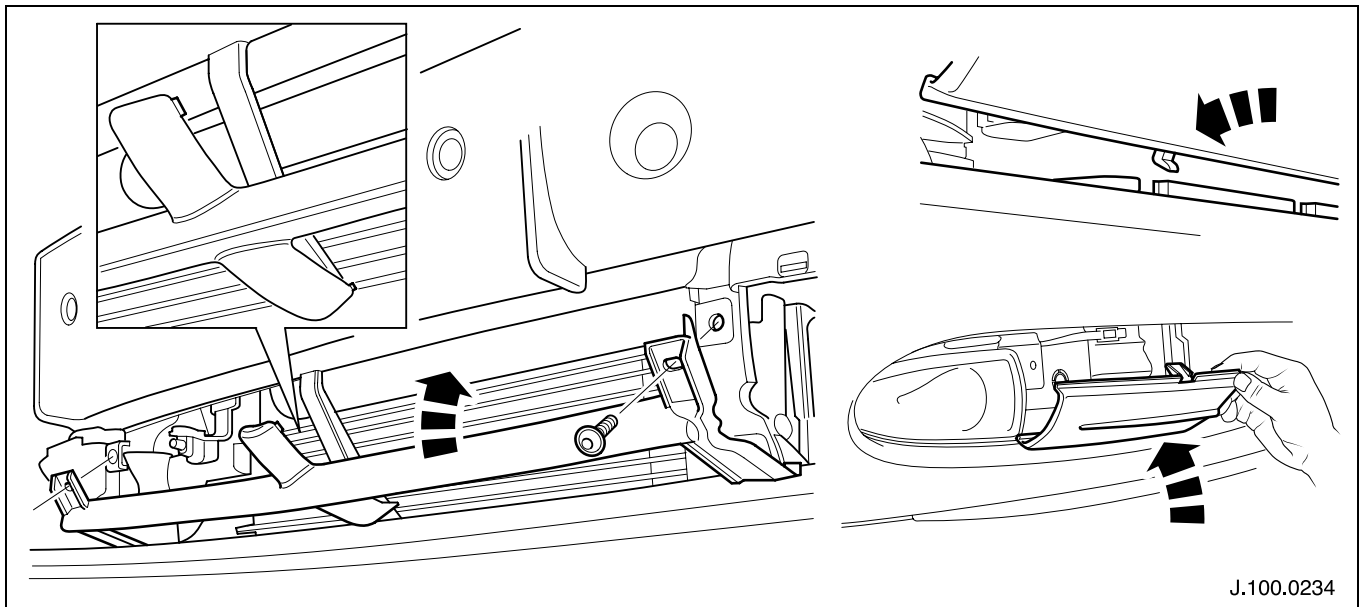

## Rear Fixings

Remove the rear towing eye. Note it has a left-hand thread and is unscrewed in a clockwise direction.

Discard the towing eye as waste material.

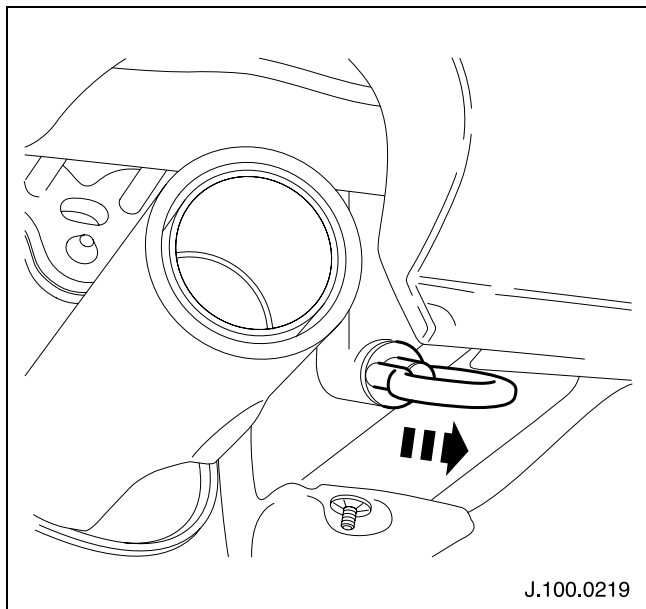

## Fire Extinguisher (Saudi Arabia only)

Fit the fire extinguisher in accordance with the fitting instructions supplied in the kit.

## Lash Down Brackets

Remove the two front lash down brackets (arrowed) and discard.

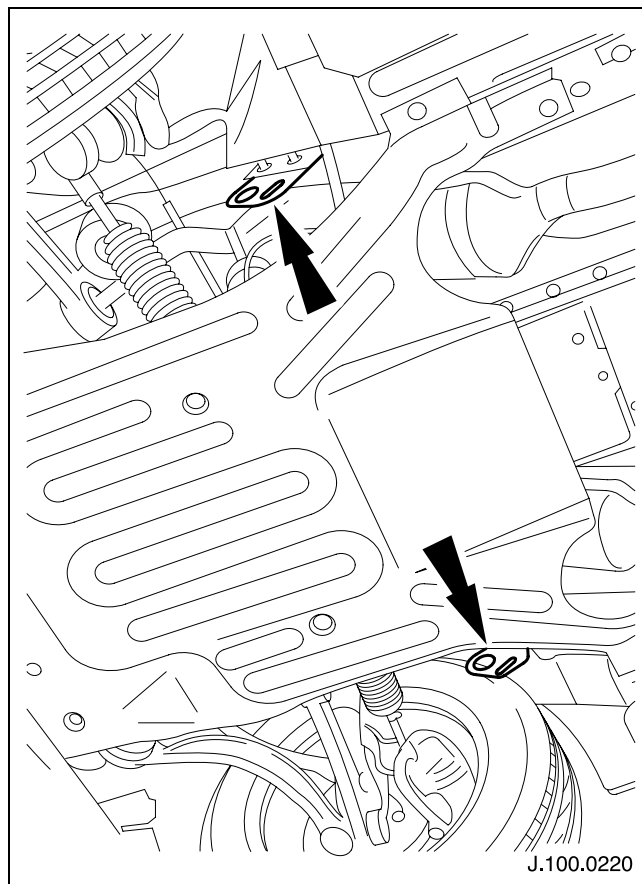

## Cigar Lighters

Push the lid below the radio/audio unit to gain access to the front cigar lighter socket. Fit the front cigar lighter. In the rear compartment, fit the rear cigar lighter.

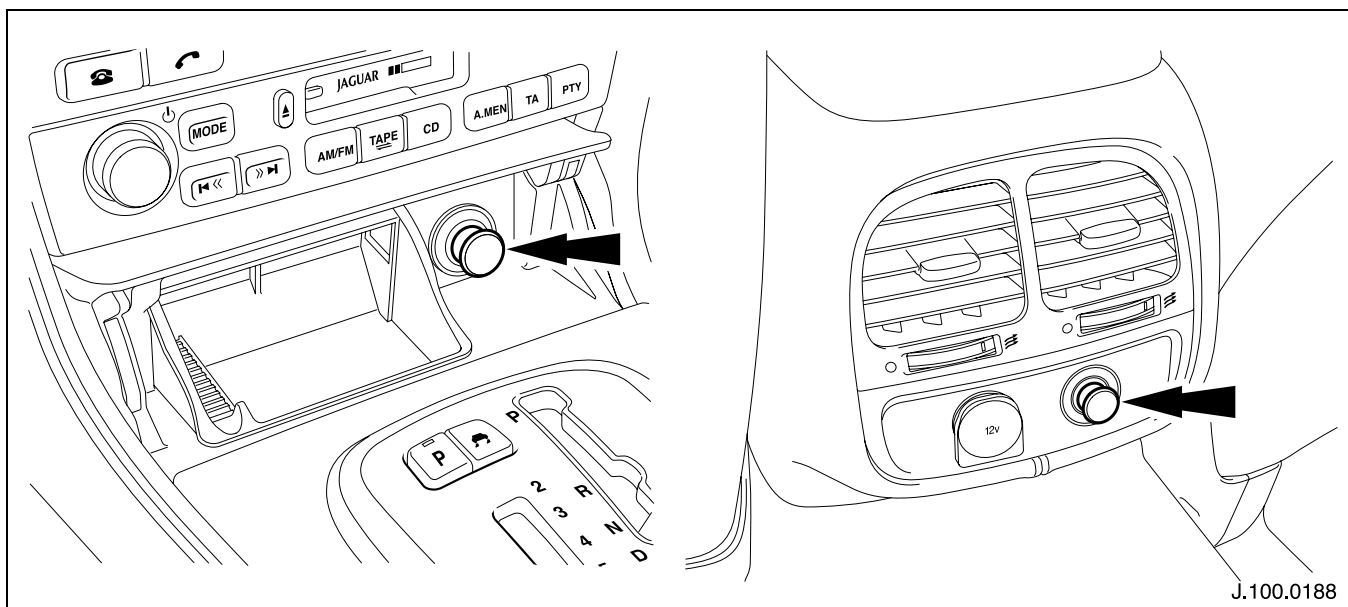

## STANDARD CHECKS: FLUID LEVELS AND TYRE PRESSURES

### Recommended Lubricants and Fluids

Component	Specification	Comments
<b>Engine 3.0L, 3.5L &amp; 4.2L</b>	Oil meeting Jaguar specification WSS M2C913-A or -B is preferred Where this is not possible use API SJ/EC and ACEA A1-98 or A3-98.  Viscosity grades SAE 0W-30, 5W-30 (preferred), 0W-40, 5W-40 for ambient temperature range -30°C (-22°F) to 50°C (122°F)	All markets except NAS
	API SL and ILSAC GF-3  Viscosity grades SAE 0W-30, 5W-30 (preferred), 0W-40, 5W-40 for ambient temperature range -30°C (-22°F) to 50°C (122°F)	NAS markets
<b>Power-Assisted Steering</b>	Dexron IIE	
<b>Braking System and Clutch System</b>	Jaguar Super DOT 4 (ESA-M6C25-A)	Use Jaguar Brake Fluid. This is a non-mineral polyglycol based brake fluid.
<b>Windscreen Wash and Headlamp Powerwash</b>	Jaguar Windscreen Washer Fluid	
<b>Cooling System</b>	WSS M97B44-D	Long life coolant – must not be mixed with other types

## Fluid Reservoirs and Dipstick Locations

XJ V8 (LHD version shown)

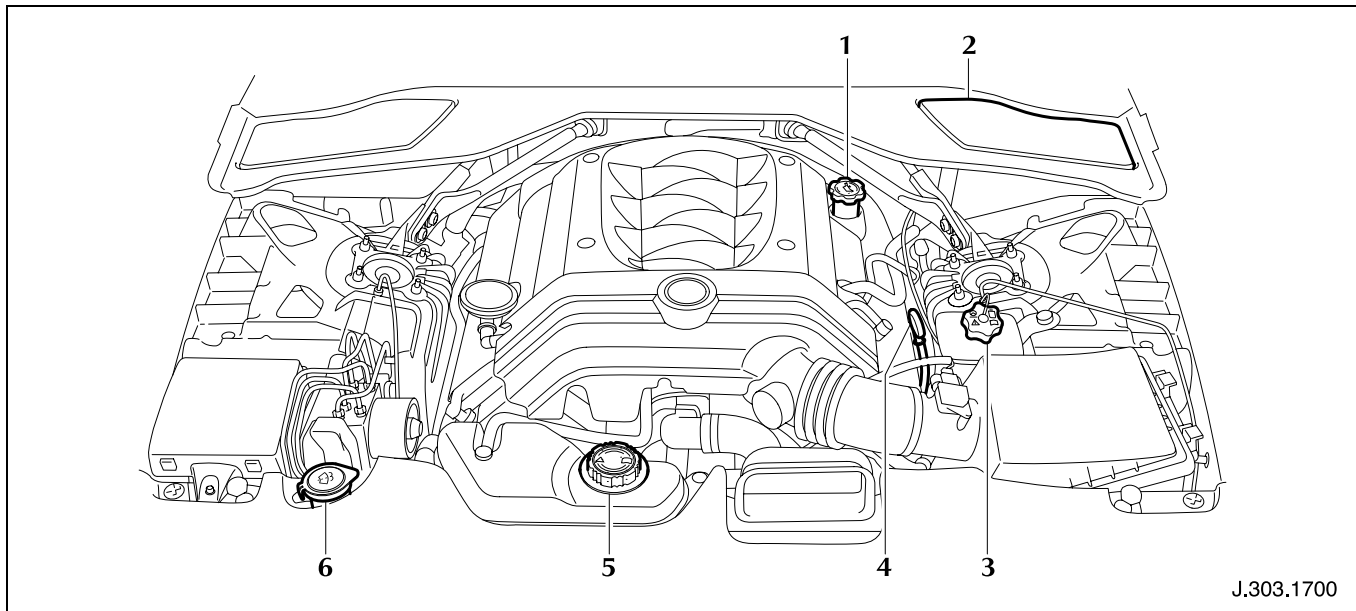

- |                                 |                                |
|---------------------------------|--------------------------------|
| 1. Engine oil filler            | 4. Engine oil dipstick         |
| 2. Brake/clutch fluid reservoir | 5. Coolant reservoir           |
| 3. Power steering reservoir     | 6. Windscreen washer reservoir |

XJ V6 (LHD version shown)

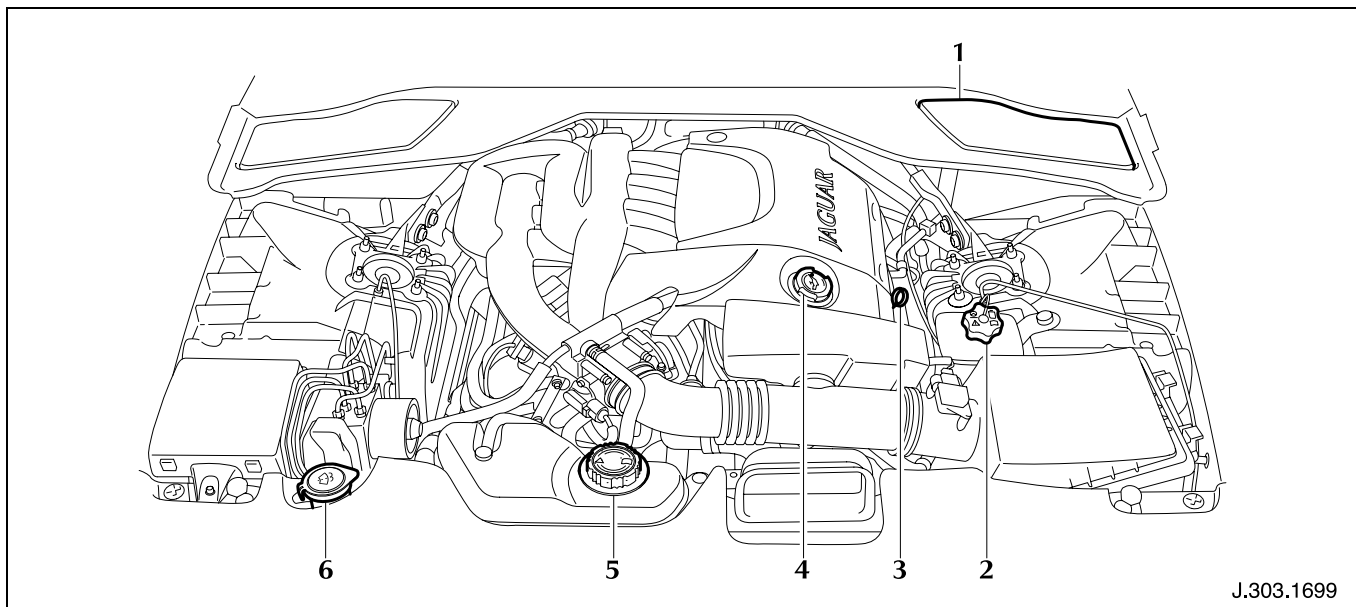

- |                                 |                                |
|---------------------------------|--------------------------------|
| 1. Brake/clutch fluid reservoir | 4. Engine oil filler           |
| 2. Power steering reservoir     | 5. Coolant reservoir           |
| 3. Engine oil dipstick          | 6. Windscreen washer reservoir |

## Fluid Leaks

When checking fluid levels always thoroughly check the particular system for leaks from hoses, pipes and reservoirs even though the fluid levels may be correct.

## Check/Top-up Engine Oil

### Engine Cold

The oil level should be checked with the vehicle on a flat, level surface and the engine completely cold, before starting. After the vehicle has stood overnight is an ideal time. If the engine has been run, even for a brief period, the oil level check **MUST NOT** be carried out until at least 1 hour has elapsed after switching off the engine.

### Engine at Normal Operating Temperature

The engine must be switched off and allowed to stand for a period of not less than 2 minutes, before the oil level is checked. This allows time for the oil in the system to drain back to the sump pan.

Checking the oil level too soon after the engine has been run will give a false low level reading, which might result in overfilling.

### Check and Top-up Procedure

Remove the dipstick (A) and wipe clean with a lint free cloth. Replace fully, then withdraw the dipstick. If the oil level is above the **LOWER DOT** on the dipstick then no additional oil is required.

If the oil level reaches the **LOWER** dot, remove the oil filler cap (B) and add 1.0 litre (1.76 imp. pint, 1 US quart) of oil.

Wait 2 minutes for the added oil to reach the sump and recheck the oil level with the dipstick.

### CAUTION:

**Do not overfill.**

Refit the filler cap and hand-tighten securely.

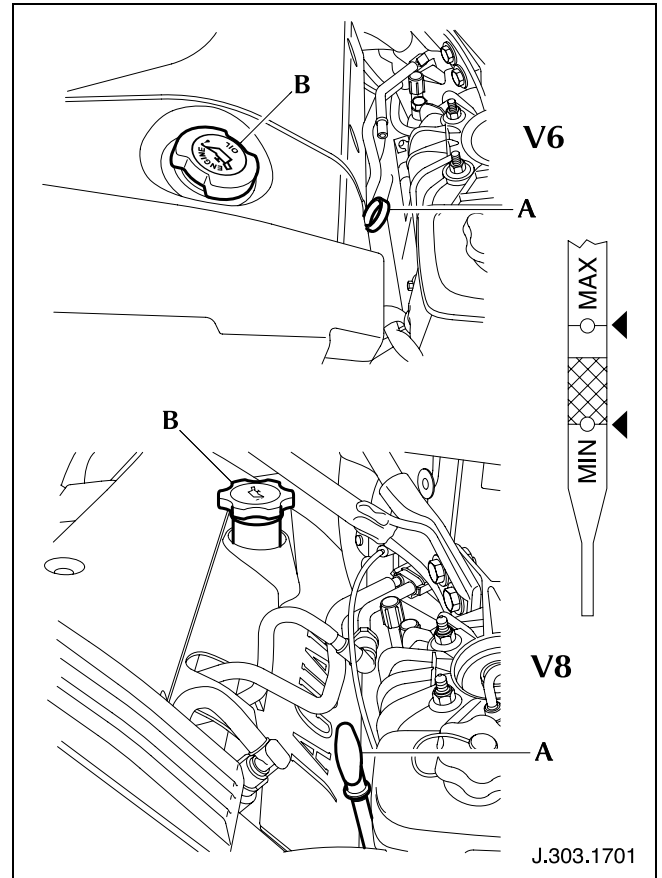

## Check/Top-up Power Steering Fluid

### CAUTION:

It is imperative that the power steering system does not become contaminated in any way. Always dispense the fluid from a fresh, sealed container and clean the area around the reservoir neck both before and after topping-up.

Never return drained fluid to the system.

The power steering fluid level should be checked when the engine is COLD, and with the vehicle standing on a flat, level surface.

**Check:** Through the sight window that the fluid level is between the two marks.

If necessary, top-up with power steering fluid to specification Dexron IIE.

### CAUTION:

**Do not overfill.**

Refit the filler cap securely.

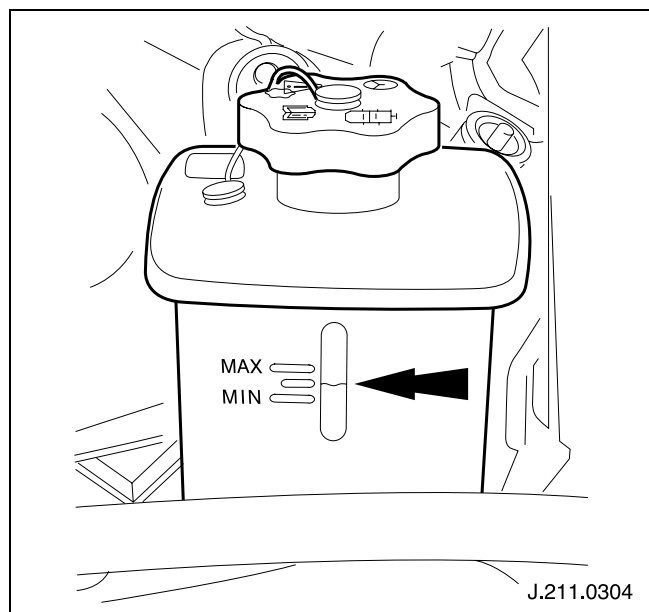

## Check/Top-up Brake Fluid

The brake fluid reservoir is concealed by a lift-out cover. To remove the lift-out cover, pull the two clips on the rear edge of the cover towards the front of the car, and lift the cover out.

### CAUTION:

While handling brake fluid, take extreme care; brake fluid **MUST NOT** contact the vehicle paintwork. Only use fresh, clean fluid from a new tin. Used fluid will have become aerated.

The fluid is visible through the translucent reservoir and must be maintained at the 'MAX' mark.

### Topping-up

Before removing the cap, clean the reservoir and cap with a lint-free cloth to ensure that no foreign matter enters the reservoir.

Unscrew the filler cap and top-up to the 'MAX' level using brake fluid to specification **Jaguar Super DOT 4 (ESA-M6C25-A)**. Refit the filler cap securely.

### Note:

To avoid contamination should any brake fluid be spilled, replace the cap on the reservoir before cleaning the spilt fluid from the vehicle.

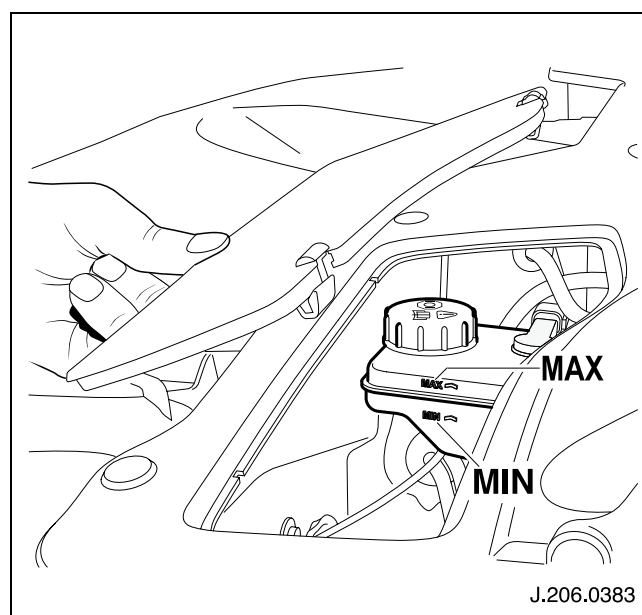

## Check/Top-up Coolant

The coolant level **MUST** only be checked when the engine is **COLD**. Plain water alone **MUST NOT** be used to top up the cooling system.



### **WARNING:**

**DO NOT REMOVE COOLANT HEADER TANK FILLER/PRESSURE CAP WHILST THE ENGINE IS HOT. IF THE CAP MUST BE REMOVED, PROTECT THE HANDS AGAINST ESCAPING STEAM AND SLOWLY TURN THE CAP SLIGHTLY ANTI-CLOCKWISE UNTIL THE EXCESS PRESSURE CAN ESCAPE. LEAVE THE CAP IN THIS POSITION UNTIL ALL THE STEAM AND PRESSURE HAS ESCAPED THEN REMOVE THE CAP COMPLETELY. FAILURE TO FOLLOW THESE INSTRUCTIONS MAY RESULT IN PERSONAL INJURY.**

**DO NOT ALLOW ANTIFREEZE TO MAKE CONTACT WITH SKIN OR EYES. IF THIS SHOULD HAPPEN, RINSE THE AFFECTED AREA IMMEDIATELY WITH PLENTY OF WATER.**

### **CAUTION:**

**Antifreeze will damage paintwork. Avoid spillage.**

**Check:** The coolant level is between the 'MAX' and 'MIN' marks located on the inside of the header tank as viewed with the cap removed.

### **Topping-up**

For protection to  $-40^{\circ}\text{C}$  ( $-40^{\circ}\text{F}$ ), the correct concentration is 50% long life coolant to specification WSS M97B44-D and 50% water.

### **CAUTION:**

**The specified long life coolant is not compatible with and must not be mixed with other type coolants. When topping up or replacing coolant, use only the specified type.**

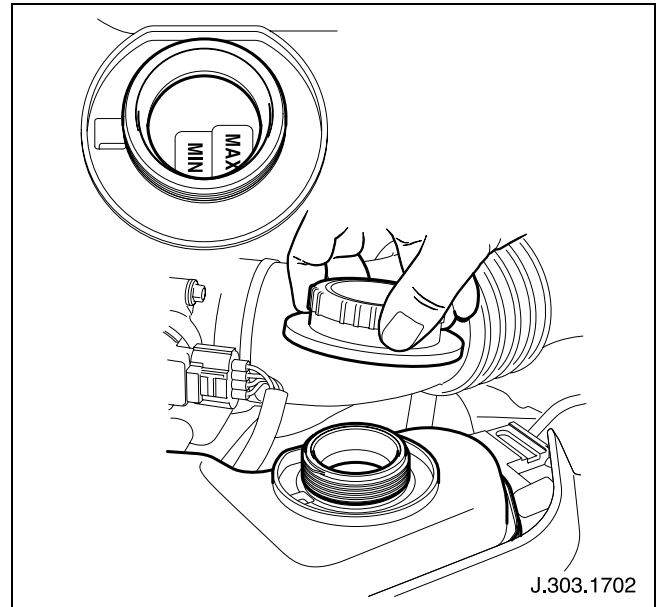

## Check/Top-up Windscreen Washer Reservoir

The washer reservoir contains fluid for the windscreen and the headlamp powerwash system (where fitted).

**Check:** Check that the reservoir level is just below the filler neck.

If necessary top-up with Jaguar Windscreen Washer Fluid diluted with clean, preferably soft, water as specified in the maker's instructions printed on the bottle.

### Note:

Using a non-approved fluid may adversely affect the wiper blade rubber, resulting in ineffectual and noisy operation.

### Cold Weather Precautions

To prevent damage to the pump under freezing conditions, use recommended fluid and windscreen washer antifreeze, then operate the pump to expel untreated fluid.



### WARNING:

**WINDSCREEN WASHER ANTIFREEZE IS TOXIC AND, IN CONCENTRATED FORM, FLAMMABLE.**

### CAUTION:

**Under no circumstance use cooling system antifreeze as this will damage paintwork.**

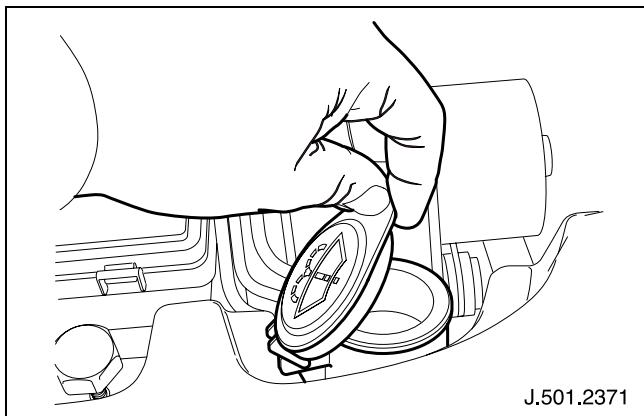

## Tyre Pressures

### Operating Pressures

When delivered, the tyre pressures are set higher than the normal operating pressures and will therefore require resetting to the correct pressures.

Set the tyre pressures recommended for normal conditions (up to 100 mph [160 km/h]) to the values shown on the label affixed to the inside of the fuel filler flap.

### Transit and Storage Tyre Pressures

Vehicles which are designated for further transport after PDI, or vehicles which are likely to stand for significant lengths of time after PDI, should have all tyres reflat, until just prior to customer handover, to a transit pressure of:

60 lbf/in<sup>2</sup> (405 kPa; 4.13 kg/cm<sup>2</sup>; 4.05 bar)

Wheels must be turned through 90 degrees in the forward direction once a week to ensure that the tread is rotated evenly during the storage period (refer also to the New Vehicle Storage Manual, JTP 944 English).



## STANDARD CHECKS: FUNCTIONAL

### Parkbrake Operation

**Check:** The parkbrake applies and releases positively.

- Pull the parkbrake switch upwards to apply the parking brakes. The parkbrake warning/brake fluid low warning light should be illuminated.
- To release the parkbrake, the ignition switch must be in position **II**; apply the footbrake and while keeping it pressed down, push the park brake switch down. The warning light should extinguish.

The parkbrake is automatically applied when the key is removed from the ignition switch. If you wish to keep the parkbrake off, hold the switch down and at the same time remove the key.

**CAUTION:**

Take care that the vehicle is safely parked to prevent it from rolling, if you wish to leave the parkbrake off.

**Note:**

If the battery has been disconnected, a message 'APPLY PARKBRAKE' will be displayed when the battery is reconnected and the ignition is next switched on. Depress the foot brake, apply, release and reapply the parkbrake. This is to reset the parkbrake and calibrate the system.

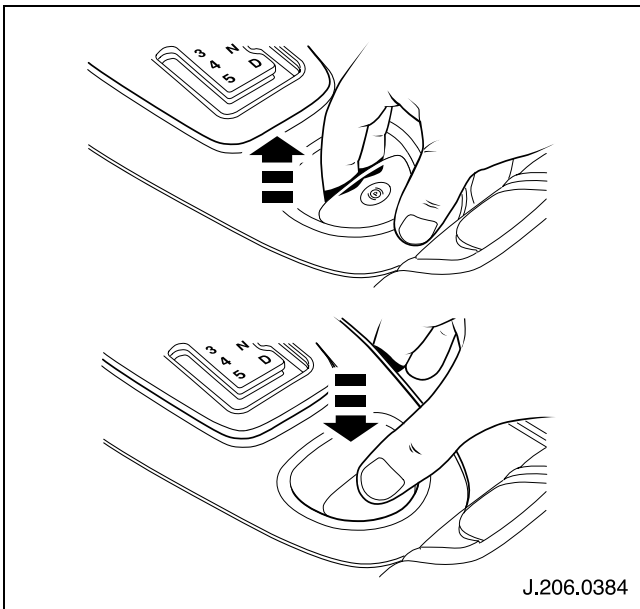

### Windscreen Washer and Wipers

**CAUTION:**

Before checking the operation of the wiper, any KATS transit coating present on the windscreen **MUST** be removed to avoid contamination of the wiper blade.

Remove any KATS transit coating from the windscreen using the specified materials and procedure. See page 28. Clean the windscreen completely using 'Jaguar Screen Clean Paste'.

Ensure that an adequate amount of water is present on the windscreen when checking the wiper system.

### Wiper Column Switch

**Check:** The wiper operation with the ignition switch at position **II**.

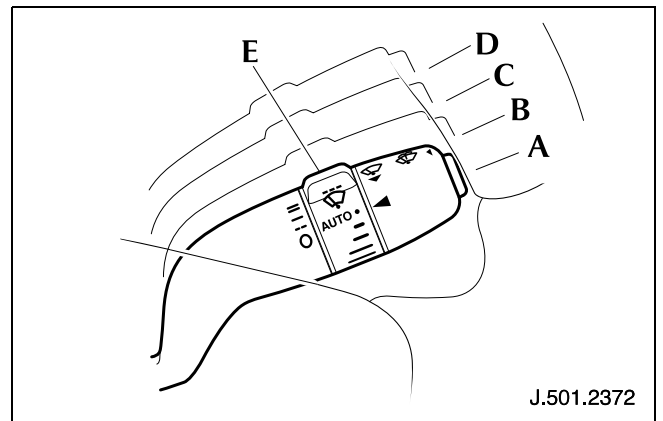

Position	Response
A	Off and Parked
B	Intermittent Wipe (see below)
C	Slow Speed Wipe
D	High Speed Wipe
E	Intermittent Wipe Variable Delay

**Flick Wipe** – Pull the column switch towards the steering wheel to give a single slow speed wipe of the blades. Holding the lever in this position operates the wiper continuously at slow speed until released.

**Intermittent Wipe (B)** – With intermittent wipe selected, turning the rotary collar (E) through the six marked switch positions varies the delay between wipes from 3 seconds (top position) to 18 seconds.

## Windscreen Wash/Wipe

**Check:** The washer operation.

Press the button on the end of the column switch to start the wash/wipe cycle. Check that the wipers operate during the washing action with the button pressed. When the button is released, a further three wipes will occur, followed by a pause of a few seconds and then a final drip wipe.

### Note:

If rain sensitive wipers are fitted and selected, the wipers will operate until no moisture is detected.

## Exterior Lighting

The exterior lights are controlled by the left-hand column stalk switch.

The rotary column on the stalk has three positions for turning the exterior lights on or off and positions for autolamps/exit delay.

**Check:** The exterior lights for correct operation.

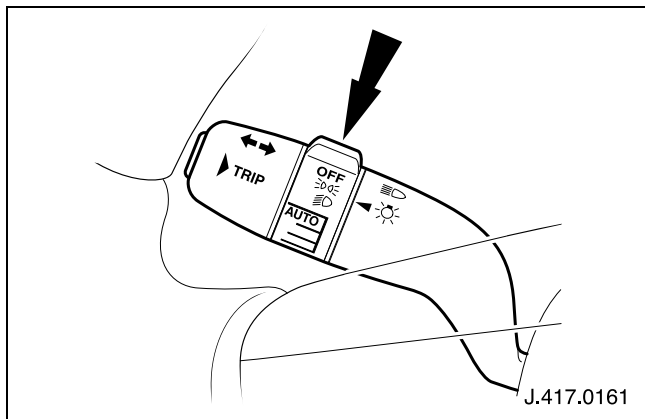

**Off:** all exterior lighting is off.

**Sidelights:** side lights, tail lights, number plate lights and other marker lights required by local legislation are illuminated. The instrument panel is also illuminated.

**Headlights:** with the ignition in position II, dipped headlights are illuminated in addition to those switched on in the sidelights position. The left-hand column stalk switch has two positions to select main beam. Pull towards the steering wheel to the first position and release to flash. Push away from the steering wheel to select main beam on and pull back to return to dipped beam.

**AUTO headlights:** with the ignition in position II and **AUTO selected**, the exterior lights are controlled by the light sensor on the front of the fascia.

**Front fog lights (A):** With the left column stalk switch in the sidelight or dip position, press the switch to turn on the front fog lights. The lights will not come on with main beam selected.

**Rear fog lights (B):** With the left column stalk switch in dipped beam position, push the switch to turn on the rear fog lights. Pushing the switch again will turn off the rear fog lights.

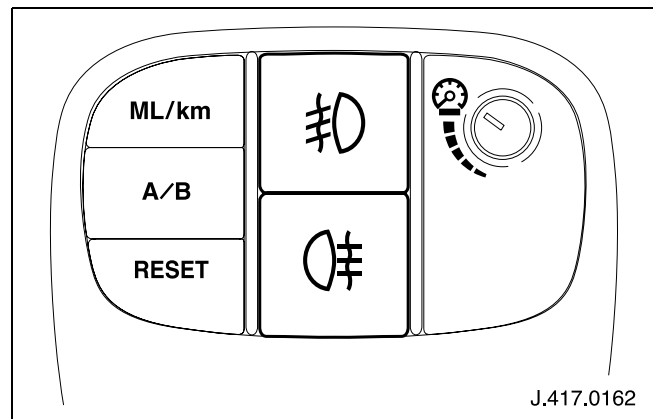

## Daylight running lights

In certain countries it is a legal requirement for the lights to be on during the hours of daylight.

With the rotary collar on the left-hand stalk switch in the OFF position, dipped headlights, sidelights, tail, number plate lights and, where fitted, side marker lights will switch on automatically with the following conditions:

- The ignition is turned to position II.
- The vehicle gear selector out of park.
- The parkbrake is not applied.

## Brake and Reversing Lights

With the ignition switch in position **II** press the brake pedal.

**Check:** Both brake lights and the high mounted stop lamp are illuminated.

With the parkbrake applied, switch the ignition to position **II** and select reverse gear.

**Check:** Both reversing lights are illuminated.

## Direction Indicators

The direction indicators operate when the ignition switch is in position **II**. Move the column switch up to turn the right-hand indicators on, and down for the left-hand indicators.

**Check:** The indicator lights flash, accompanied by a flashing green arrow on the main instrument panel and a ticking sound.

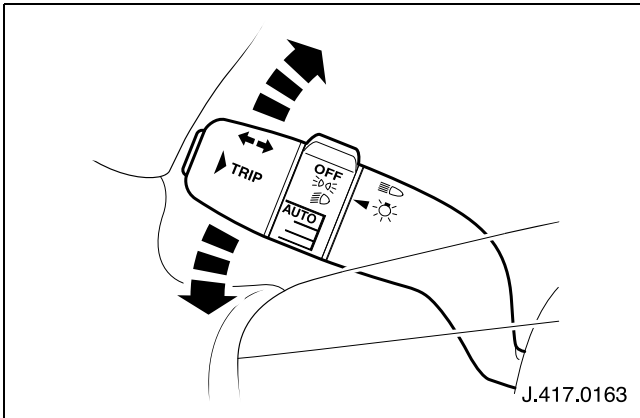

On the road test, check that the column switch cancels when the turn is completed.

### Note:

Should a direction indicator bulb fail, the corresponding side green tell-tale light will flash at twice the normal rate. The audible ticking will sound at twice the normal rate.

## Hazard Warning Light

The switch is located on the centre console and operates with the ignition on or off.

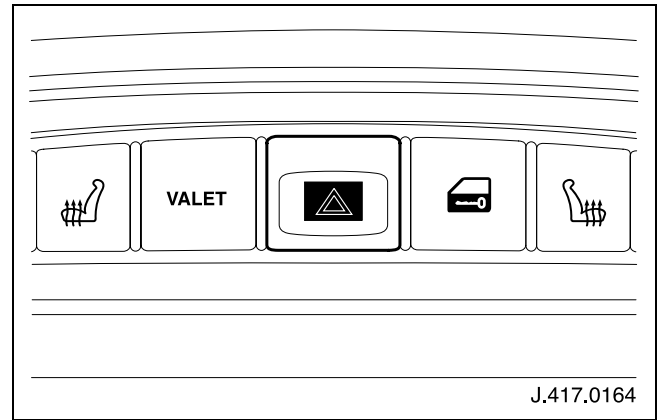

With the ignition on, press the hazard warning switch.

**Check:** All direction indicators and the instrument cluster green arrows flash in unison with an audible warning.

## Door Mirror Adjustment

Both mirrors are adjusted from the driver's door switch pack (LHD version shown). The selector switch (B) selects which mirror is to be adjusted. The four-way adjustment button (A) adjusts the mirror to the required position.

Push the selector switch to the left.

**Check:** The left-hand rear view door mirror moves with the adjustment button.

Push the selector switch to the right and repeat the above operation for the right-hand rear view door mirror. Push the selector switch to its central position.

**Check:** The adjustment button is inoperative.

Press the powerfold mirrors button (C).

**Check:** The mirrors fold inwards.

Press button (C) again to return the mirrors to their normal driving position.

Select reverse gear for the passenger's side mirror to dip.

**Check:** The mirror inclines downwards.

Move the gear selector out of reverse.

**Check:** The passenger's side mirror returns to its original position.

If mirror dip does not operate, it will need to be activated with WDS.

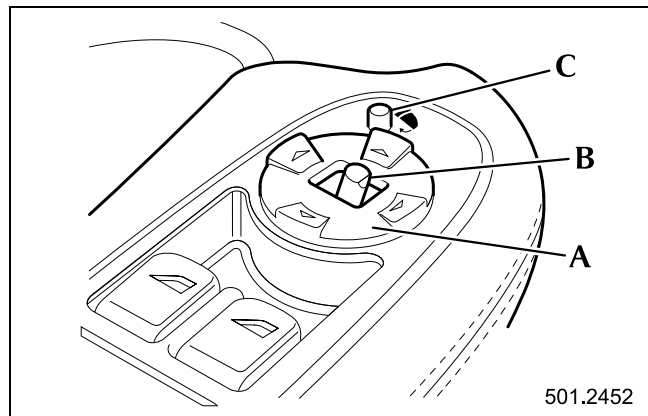

## Seat Belts

The warning lamp lights when the ignition is ON and:

- The driver's seat belt is not fastened.
- A passenger is sitting in the front seat and their seat belt is not fastened.

### Note:

In some countries a 'Beltminder' supplemental feature is fitted. If the vehicle is moving above 10 mph (16 km/h) and one or both front seats are occupied and a seat belt is not fastened, a warning chime will be heard and the lamp will flash.

**Check:** That with the driver's seat belt fastened and unfastened, the appropriate warning lamp lights. Repeat by sitting in the passenger seat.

The vehicle is fitted with lap/shoulder seat belts with inertia reel locking.

**Check:** The operation of the seat belt inertia locks by sharply pulling each belt in turn. The belts can be fastened and released correctly.

## Horn

Press the centre pad on the steering wheel to operate the dual tone horn.

## ROAD TEST

### Pre-Road Test

Before road testing the vehicle on a public highway, ensure the driver's vision is not obscured by labels.

### Brake Disc Transit Protection Bags

The transit protection bags on all brake discs are to be left in place during the road test.

When listening for vehicle noises (rattles, squeaks, etc.) during the road test, note that the transit protection bags create a certain amount of noise.

### Ignition and Gearshift Interlocks

**Check:** The gearshift lever is locked in the **P** position and the ignition key can be inserted.  
That, with the ignition key at position **II** and the brake pedal depressed, the gear lever can be moved from the **P** position.  
That all gear positions can be selected and that the gear lever locks positively in the **P** position.

### Ignition On

**Check:** The driver's seat position adjustments.  
The steering lock is released when the ignition key is inserted.  
The steering column can be adjusted over the full range for tilt and reach. The optionally fitted adjustable pedals can be adjusted over the full range of reach.  
The Sport mode switch on the 'J' gate surround lights up when sport mode is selected and goes out when deselected.

### Starting

**Check:** The engine will only start when the selector lever is in the **P** or **N** position.  
The starter motor operates without undue noise and starts the engine easily.  
The tachometer registers as the engine is started.  
The fuel and coolant temperature gauges are registering correctly.  
The oil pressure lamp and battery condition warning lamps are OFF.

## On the Open Road

### Important:

**Optimum braking efficiency is only achieved after bedding-in brake disc/pads. It is therefore important to avoid repeated hard use of the brakes during the PDI Road Test.**

**Check:** Parkbrake operation. See page 15.  
That the steering self-centres from the right-hand and left-hand locks.  
The vehicle shows no tendency to wander or pull to one side.  
The steering wheel is properly aligned when the wheels are steered straight ahead.  
The direction indicators cancel when the steering wheel is turned onto the appropriate lock.  
The brakes do not pull to one side but operate smoothly without judder or noise.  
All gear changes are smooth.  
Throttle pedal action.  
The 'kickdown' feature operates correctly when changing down gear.  
All wash/wiper functions, horn, exterior lights and headlight levelling.  
Cruise control system. See page 20.  
Climate control system. See page 22.  
Without turning the ignition off, the MIL and warning lamps are not illuminated.

### Important:

**The Road Test is the last opportunity to assess the quality of ride, handling, general performance and noise levels under differing traffic and road conditions. Every care must be taken to ensure that the vehicle performs to the standard of excellence expected by our customers.**

## After Road Test

The following checks should be made immediately after the road test:

**Check:** Both above and under the engine for any oil, fuel, fluid or water leaks.  
All pipes and hoses are securely clipped in their anchorages, and that no chafing has occurred or is likely to occur in the future.

If any leaks are found then the appropriate remedial action should be taken.

**Check:** For any exterior damage.

## Cruise Control



**WARNING:**  
**ONLY USE CRUISE CONTROL WHEN CONDITIONS ARE FAVOURABLE, E.G. ON STRAIGHT, DRY, OPEN ROADS WITH LIGHT TRAFFIC.**

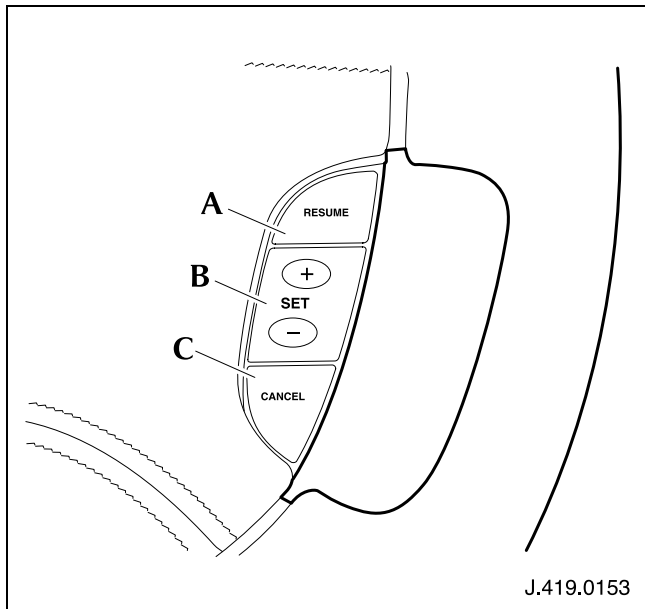

**Controls** – all cruise control switches are located on the steering wheel switchpack:

**RESUME (A)** – press to resume the set speed retained in memory.

**SET (B)** – press + to switch the cruise control ON and set the speed or increase/decrease the set speed (without using the accelerator). Speeds above approximately 17.5 mph (28 km/h) may be set.

**CANCEL (C)** – press to cancel cruise control but retain the set speed in memory.

When the system is switched ON, the statement 'CRUISE ENGAGED' is displayed on the message centre.

Pressing the brake pedal while in cruise control disengages the system in the same way as using the **CANCEL** button.

If the vehicle is accelerated above the set speed, then the set speed will be resumed when the accelerator pedal is released.

**Road test** – use the road test to establish that cruise control operates correctly and can be disengaged quickly.

**Check:** The set speed can be immediately overridden (cruise disengaged) using the **CANCEL** button and the brakes, and the clutch (press the **RESUME** button after each cancellation to return to the set speed).

The set speed can be immediately overridden (cruise disengaged) by using the accelerator.

For reference, full operation of the cruise control system is given in Section 4 of the Driver's Handbook.

## Adaptive Cruise Control (ACC)



### WARNING:

**ADAPTIVE CRUISE CONTROL IS NOT A COLLISION WARNING OR AVOIDANCE SYSTEM.**

**IT IS THE DRIVER'S RESPONSIBILITY TO STAY ALERT, DRIVE SAFELY AND BE IN CONTROL OF THE VEHICLE AT ALL TIMES.**

**ONLY USE CRUISE CONTROL WHEN CONDITIONS ARE FAVOURABLE, E.G. ON STRAIGHT, DRY, OPEN ROADS WITH LIGHT TRAFFIC.**

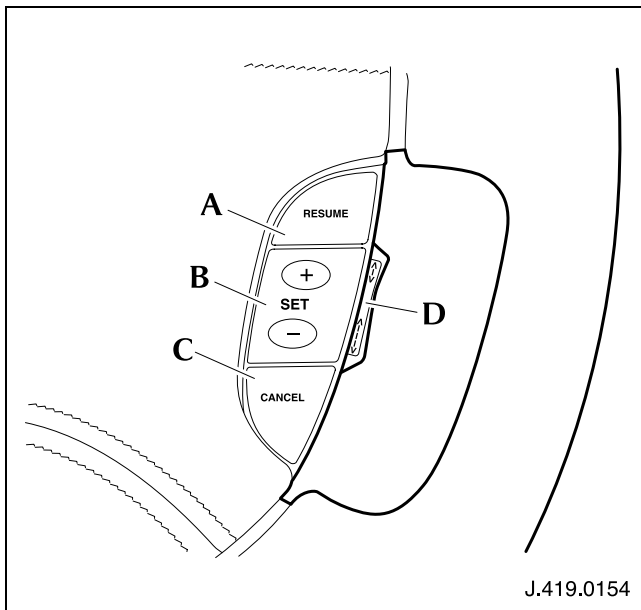

**Controls** – all cruise control switches are located on the steering wheel switchpack:

**RESUME (A)** – press to resume the set speed retained in memory.

**SET (B)** – press + to switch the cruise control ON and set the speed or increase/decrease the set speed (without using the accelerator). Speeds above approximately 20 mph (34 km/h) may be set.

**CANCEL (C)** – press to cancel cruise control but retain the set speed in memory.

**GAP SWITCH (D)** – gap to the vehicle ahead; decrease or increase.

When the system is switched ON, the statement 'CRUISE ENGAGED' is displayed on the message centre.

Pressing the brake pedal while in cruise control disengages the system in the same way as using the **CANCEL** button.

If the vehicle is accelerated above the set speed, then the set speed will be resumed when the accelerator pedal is released.

**Road test** – use the road test to establish that cruise control operates correctly and can be disengaged quickly.

**Check:** A cruise set speed can be selected and adjusted using the +/- **SET** button and accelerator.

The distance (time gap) from the vehicle ahead can be adjusted by pressing the buttons (**D**) on the steering wheel.

The 'Follow mode' tell-tale in the instrument cluster will be illuminated and the message centre will display the gap set when following a slower vehicle.

The set speed can be immediately overridden (cruise disengaged) using the **CANCEL** button, or the brakes (press the **RESUME** button after each cancellation to return to the set speed).

The set speed can be temporarily overridden (cruise interrupted) by using the accelerator. A 'Forward Alert' button is fitted on the lower outboard knee bolster switchpack: With the vehicle stationary, switch the feature on (tell-tale on). Press the lower gap increase button (**D**) to increase the sensitivity of the Alert to maximum. Switch off the Forward Alert (tell-tale off) so that the customer receives the vehicle with the switch set in this condition.

For reference, full operation of the cruise control system is given in Section 4 of the Driver's Handbook.

## Climate Control

The vehicle is fitted with one of the following front climate control systems:

- Automatic climate control system with an LCD (liquid crystal display) screen.
- Automatic climate control system with touch screen (shared with the navigation and audio systems).

The vehicle is also fitted with a rear climate control panel for rear passenger zones, when the front control system is operating.

### Automatic Climate Control with LCD Display:

- 1 Fan speed and system push on/off switch
- 2 Display panel with typical symbols
- 3 Celsius/Fahrenheit selector
- 4 Air conditioner on/off
- 5 Select automatic operation
- 6 Recirculated/fresh air
- 7 Increase RH zone temperature
- 8 Decrease RH zone temperature
- 9 Select Air Distribution
- 10 Heated rear screen/door mirrors
- 11 Heated front screen
- 12 Defrost Windows
- 13 Select dual/single temperature zone
- 14 Increase LH zone temperature
- 15 Decrease LH zone temperature
- 16 Option without front screen heater

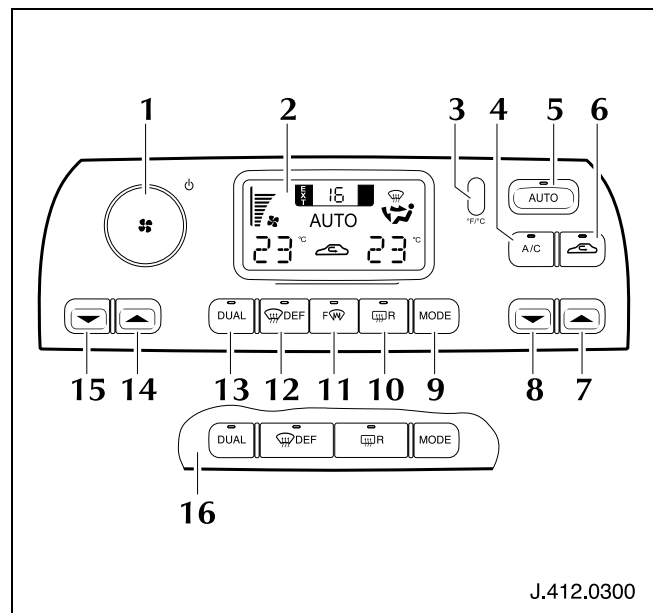

### Automatic Climate Control with Touch Screen:

- 1 Select climate control touch screen
- 2 Fan speed
- 3 Automatic operation
- 4 Decrease LH zone temperature
- 5 Increase LH zone temperature
- 6 LCD screen: interior/exterior temperatures and clock
- 7 Decrease RH zone temperature
- 8 Increase RH zone temperature
- 9 Heated rear screen/door mirrors
- 10 Heated front screen (optional)
- 11 Defrost operation
- 12 Select recirculated air
- 13 Touch screen

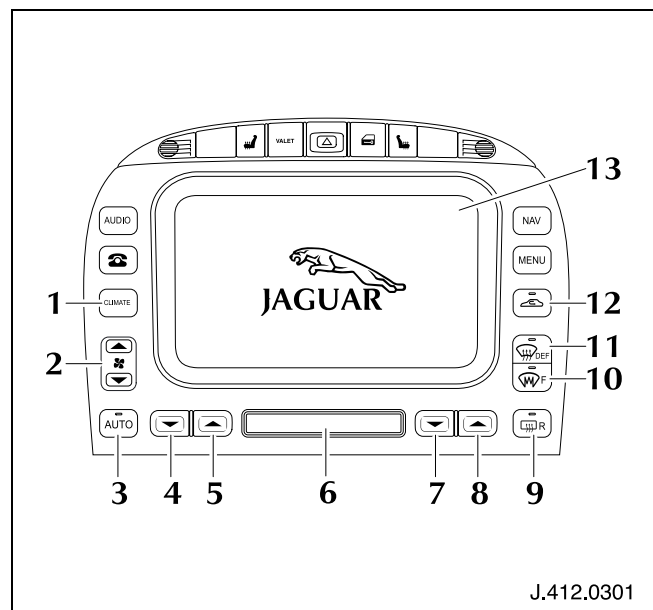



**Rear Climate Control:**

- 1 Blower speed and system ON/OFF
- 2 Display panel
- 3 Increase right zone temperature
- 4 Decrease right zone temperature
- 5 Select automatic operation
- 6 Select air distribution
- 7 Increase left zone temperature
- 8 Decrease left zone temperature

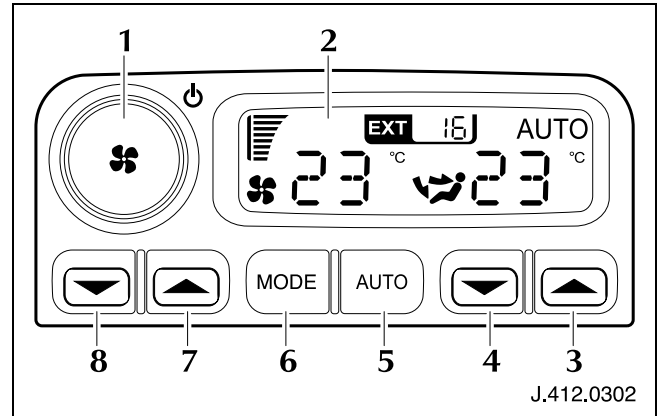

**Check:** The general operation of the climate controls: e.g. temperature adjustment, fan speeds, air distribution modes, air recirculation, **AUTO** selection.

Set the automatic climate control systems to a midrange temperature of 23°C (73°F) for customer handover.

## FINAL PREPARATION

The following should be carried out just prior to handing over the vehicle to the customer.

### Brake Disc Transit Protection Bags

Remove the plastic transit protection bags from all brake discs as follows.

Position the vehicle on a ramp, cut (DO NOT TEAR) the bag along the perforations and carefully remove from around the brake discs.

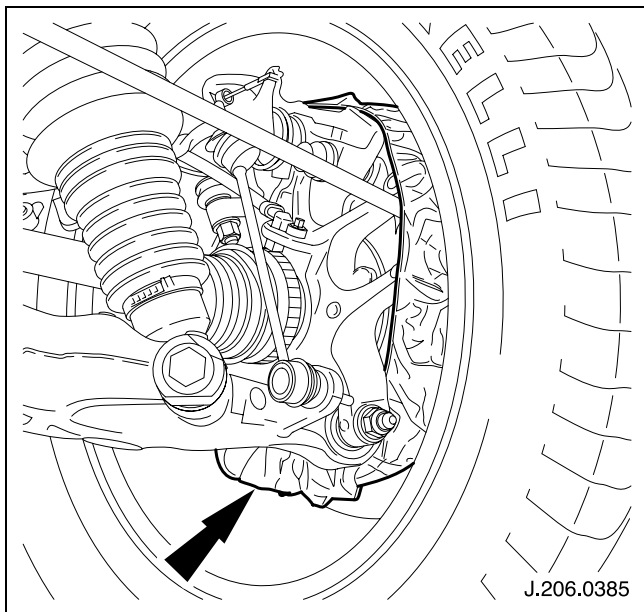

### Tyre Pressures

Check that tyre pressures are correctly set to the comfort setting. See page 14.

### Removing the Transit Relay

Remove the transit relay, reconnect and reset the air suspension and reconnect the battery not more than 24 hours before hand-over to the customer. See page 3.

On reconnection it is important to:

- Reset the kickdown travel limits. See page 5.
- Reset the anti-trap/one-touch close function on all electrically operated door window. See page 6.
- Enter the audio security code, if applicable. See page 5.
- Set the clock. See page 6.
- Enable the Security System Battery Backed Sounder, where fitted. See page 5.
- Reset the parkbrake. See page 6.

### Return Procedure for Transit Relay

- Place the relay in the dedicated returns box and store in a dry area until the box is full.
- When the box is full, return using the normal Warranty returns procedure, ensuring that the quantity of relays is clearly recorded on the Warranty Return Advice Note.

### Note:

Ensure that the Transit Relays are not tampered with, no labels are affixed or markings applied. Keep free from grease, etc.

## Airbag warning label (USA/Canada)

National Highway Traffic Safety Administration (NHTSA) – MANDATORY fitment of Airbag Warning label

Open the glove compartment to gain access to fit the Airbag Warning Label. Loop the elastic around the lid's outboard latch. Close the lid, leaving the label hanging on the outside of the glove compartment, so that it is clearly visible to the owner of the new vehicle at the time of hand-over.

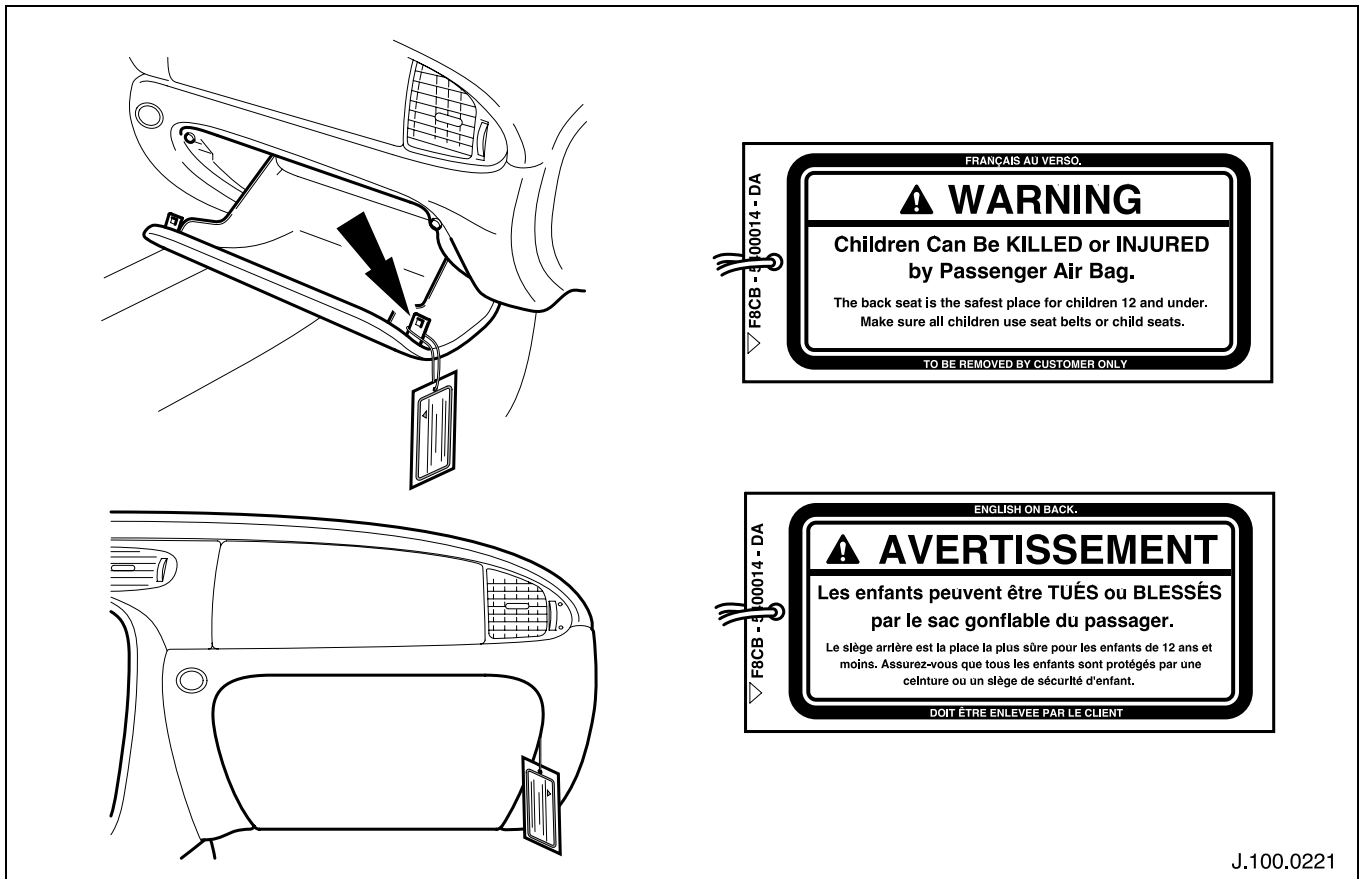

## Navigation System (where fitted)

The navigation system, if fitted, includes the telematics display/touch screen unit in the centre console and the DVD navigation unit in the trunk.

A DVD, containing the map information, is supplied loose in the trunk. Ensure that the map DVD is the correct version for the particular country or region.

- 1 Turn on the ignition (position I).
- 2 Using the finger recess below the top edge (**A**), pull the top of the access cover forward and fold it downwards to the fully open position (top illustration, trunk view).
- 3 Identify the navigation unit, which is positioned above the sound system CD player (where fitted).
- 4 Push the eject button (**C**) to see if a DVD is already loaded and if so, remove it. Load the map DVD with the printed side upwards (**D**). Do not allow moisture or foreign objects to enter the slot.
- 5 Fold the access cover to the fully closed position. Check that the magnetic catch is properly secured.
- 6 On the telematics display and control panel, press the **NAV** button (see illustration); the road safety **CAUTION** screen is displayed.
- 7 Remove the protective film from the telematics screen.
- 8 If the language is correct, go to step 11.
- 9 If another language is required, touch the bottom left-hand screen button (globe symbol); the **USER SETTINGS** screen is displayed.
- 10 Touch the Language Change screen button; the **LANGUAGE SELECTION** screen is displayed. Touch a language button and then touch **OK** (scroll as required); the system returns to the **USER SETTINGS** screen. Touch **Cancel** to return to the **CAUTION** screen.
- 11 Touch the **Agree** screen button; a map screen is displayed (bottom illustration).

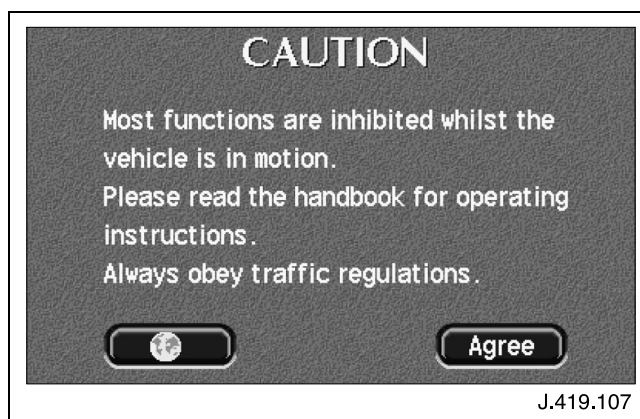
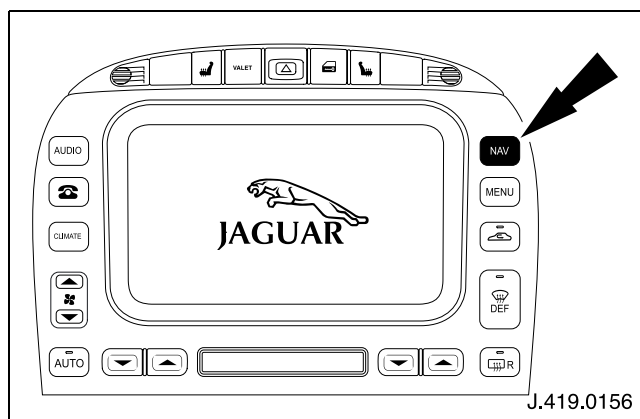
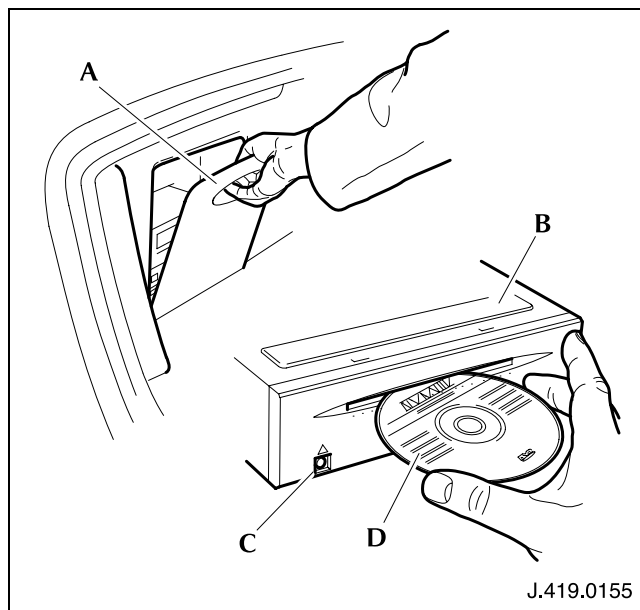

- 12 Move the vehicle to an open location where the GPS (Global Positioning System) satellite signals can be received. A GPS symbol may appear at the top of the screen (see opposite). This symbol normally indicates poor signal reception but also appears if the system requires initialisation, such as after transportation (the map location will also be wrong).
- 13 Leave the vehicle with the ignition switched on for 15 minutes. The navigation system will initialise itself automatically, causing the GPS symbol to disappear and the map to show the correct location. If the correct location is still not shown, refer to 'Calibration' in the Navigation handbook.
- 14 Touch the **Nav Menu** button to select the Navigation menu.
- 15 Touch the **Destination Entry** button to select the Destination Entry menu.
- 16 Touch the change button to select the Search Area menu in Europe. For Australia go to step 19. The current area is shown highlighted on the map and the countries it covers are listed at the bottom of the screen.
- 17 From the list displayed, select the touch button required for the area in which the vehicle is to be driven, see the following list. If a new area was selected, the screen shows the new area highlighted and the list of particular countries covered.

	Area	Countries
A	Austria	Austria
B	Belgium	Belgium
CH	Switzerland	Switzerland, Liechtenstein
D	Germany	Germany
DK	Denmark	Denmark
E	Spain	Spain, Andorra
F	France	France, Monaco, Andorra
GB	Great Britain	England, Scotland, Wales
I	Italy	Italy, San Marino, Vatican City
L	Luxembourg	Luxembourg
NL	Netherlands	The Netherlands
P	Portugal	Portugal
S	Sweden	Sweden

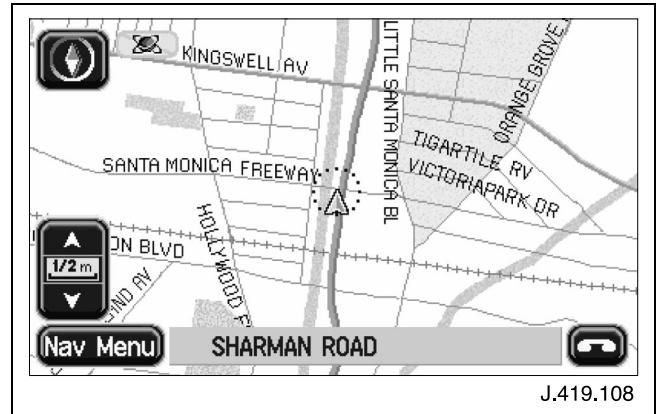

J.419.108

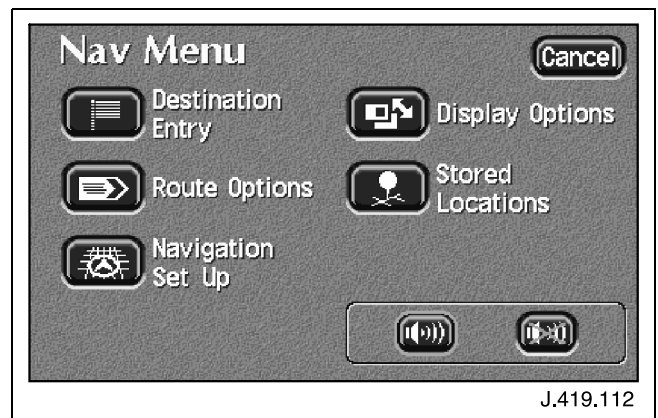

J.419.112

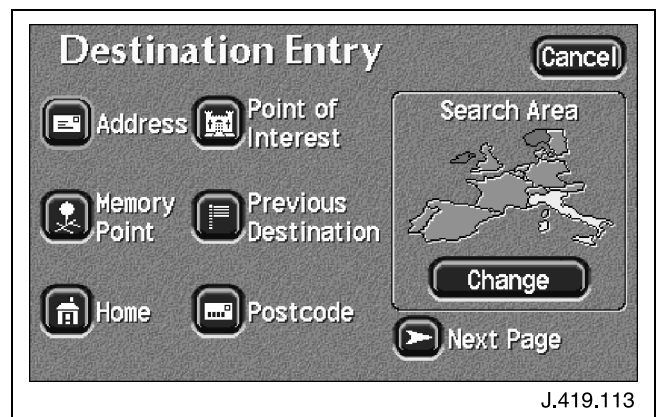

J.419.113

- 18 Press the **OK** button. The screen returns to the Destination Entry menu.
- 19 Changing search area in Australia: touch **Change**. The current area selected is shown highlighted on the map. From the three buttons displayed, select the button required for the new area. The screen shows the new area highlighted.
- 20 Turn off the ignition.

## Removal of KATS Transit Coating

### CAUTION:

**KATS 8077 Remover is the only product compatible with KATS 5080 Transit Coating and must always be applied in diluted form.**

**DO NOT attempt to remove the transit coating with any other product as chemical damage to the body paintwork, trim, or mouldings may occur.**

### Waste Disposal



### WARNING:

**KATS TRANSIT COATING AND REMOVER FLUIDS MUST BE DISPOSED OF IN AN ENVIRONMENTALLY SAFE MANNER.**

For the waste disposal of KATS coating and remover, consult the local water controlling authority. Permission may be given for small quantities, on an infrequent basis, to be disposed of via the local waste water drainage system. If this permission is not given, both the coating and its remover should be prevented from entering into drains, sewers or water courses.

Contain and absorb the waste using an inert absorbent such as dry earth, sand or a proprietary absorbent material. Place the waste into sealable containers and dispose of via a waste disposal contractor.

### Equipment Required

- A **710 ml (24 ounce)** plastic bottle of KATS 8077 Remover. This is supplied with the vehicle and is located in the rear luggage compartment.
- KATS DECOATER GUN (special tool) with a minimum tank capacity of 5 litres (1 gallon).
- High pressure cold water jetwasher.
- Chamois leather or equivalent. (For 'drying off' purposes only.)

**The following protective clothing should be worn by persons involved in removing the KATS 5080 Transit Coating from the vehicle:**

- Rubber boots.
- Rubber gloves.
- Safety goggles.

### Vehicle Preparation

- The vehicle should be placed in a shaded, non-windy area. The recommended environment is normal room temperature of approximately 20°C (68°F).
- The vehicle must be cool to avoid rapid drying of the remover solution.
- A rain soaked vehicle must first be dried so that the remover solution is not further diluted.

- A vehicle covered in snow or frost must be thawed out, rinsed off and then dried and allowed to warm up before applying the remover solution.
- Wiper blades must be off the windscreen, or the blade rubbers protected, prior to carrying out the removal process. The KATS material or remover must NOT be allowed to contaminate the blade rubbers.

### Procedure

- 1 Transfer the KATS 8077 Remover to the KATS (Special Tool) Decoater Gun. The gun automatically mixes the fluid to the correct solution when spraying.
- 2 Using the Decoater Gun, apply a fine spray of the diluted remover solution to the vehicle surface starting at the roof, then along the upper surfaces. Spray continuously, working progressively around and down the vehicle as quickly as possible, while applying a thorough spray to ALL surfaces. Continue to move around the vehicle, re-applying the spray as necessary to ensure that all surfaces are fully treated and kept wet with the remover solution.
- 3 Allow a minimum soak time of **2 – 3** minutes after ALL surfaces have been sprayed before washing off the remover solution.
- 4 It is important that the surfaces remain wet during this soak time. Re-apply the remover solution on any drying surfaces. **DO NOT** rub or agitate the remover solution on the surface of the vehicle.
- 5 Use a high pressure cold water spray to remove all traces of the remover solution. Start washing off from the roof of the vehicle and then work downwards.
- 6 Carefully inspect for any areas where the transit coating may still remain. Re-apply remover solution as necessary, allow **2 – 3** minutes soaktime and then wash off with the pressurised washer. **DO NOT** rub or agitate the remover solution on the surface of the vehicle.

### CAUTION:

**To avoid damage to paintwork, trim, mouldings, etc., do not, under any circumstances apply undiluted remover to any part of the vehicle.**

- 7 Rinse off the vehicle well and dry immediately using a chamois leather or equivalent to prevent water spotting.

## Valeting

### Carry out all final valeting:

- Remove all interior transit protection.
- Clean the bodywork and inspect for damage and blemishes.
- Valet the vehicle's interior and exterior including the windscreen.

## Owner Literature

The vehicle owner handbooks are supplied in a sealed literature pack in the trunk.

Open the literature pack and check that the contents are supplied in the correct language. The contents of the pack varies according to the market and vehicle specification. Check that there are Handbooks enclosed to cover the optional features on the particular vehicle, e.g. In-car telephone Handbook; Touch-screen Handbook; Rear Multimedia Handbook; JaguarVoice Handbook.

Open the rear centre armrest and place the 'Quick Guide' inside the rear section.



**JAGUAR**