

Fig. 01.3**COMPONENTS**

Component	Connector(s)	Connector Description	Location
PASSENGER (PRIMARY) JUNCTION FUSE BOX	CR6	10-WAY / BLACK	CABIN / RH 'A' POST
	CR47	11-WAY / BLACK	
	CR48	11-WAY / BLACK	
	CR49	10-WAY / BLACK	
	CR56	10-WAY / BLACK	
	EC7	15-WAY / BLACK	
	EC55	11-WAY / BLACK	

HARNESS IN-LINE CONNECTORS

Connector	Connector Description / Location	Location
CC7	10-WAY / GREY / TELEMATICS HARNESS TO CENTER CONSOLE HARNESS	CABIN / BELOW CENTER CONSOLE
DD1	22-WAY / BLACK / CABIN HARNESS TO DRIVER DOOR HARNESS	CABIN / DRIVER SIDE 'A' POST
DD3	10-WAY / GREY / DRIVER DOOR HARNESS TO INSTRUMENT PANEL HARNESS	CABIN / DRIVER SIDE 'A' POST
IP1	10-WAY / GREY / CABIN HARNESS TO INSTRUMENT PANEL HARNESS	CABIN / BEHIND DRIVER SIDE INSTRUMENT PANEL END PLATE
IP22	16-WAY / BLUE / CABIN HARNESS TO INSTRUMENT PANEL HARNESS	CABIN / BEHIND INSTRUMENT PANEL END PLATE / LH SIDE (LHD), RH SIDE (RHD)
IP51	10-WAY / GREY / ENGINE COMPARTMENT HARNESS TO INSTRUMENT PANEL HARNESS	CABIN / BEHIND INSTRUMENT PANEL END PLATE / LH SIDE (LHD), RH SIDE (RHD)
PD1	14-WAY / BLUE / CABIN HARNESS TO PASSENGER DOOR HARNESS	CABIN / PASSENGER SIDE 'A' POST
RC2	8-WAY / BLACK / TELEMATICS HARNESS TO REAR IN-CAR ENTERTAINMENT CONTROLS HARNESS	CABIN / BELOW CENTER CONSOLE
SD1	4-WAY / GREY / DRIVER SEAT HARNESS TO CABIN HARNESS	CABIN / BELOW DRIVER SEAT
SD28	20-WAY / BLACK / DRIVER SEAT HARNESS TO CABIN HARNESS	CABIN / BELOW DRIVER SEAT
SP1	4-WAY / GREY / PASSENGER SEAT HARNESS TO CABIN HARNESS	CABIN / BELOW PASSENGER SEAT
SP28	20-WAY / BLACK / PASSENGER SEAT HARNESS TO CABIN HARNESS	CABIN / BELOW PASSENGER SEAT
TL31	14-WAY / GREY / CENTER CONSOLE HARNESS TO TELEMATICS HARNESS	CABIN / BELOW CENTER CONSOLE / RH SIDE OF TRANSMISSION TUNNEL
TL93	8-WAY / BLACK / CENTER CONSOLE HARNESS TO TELEMATICS HARNESS	CABIN / BELOW REAR CENTER CONSOLE

Refer to the front of this book for detailed information and illustrations regarding the location and identification of harnesses, relays, fuses, grounds, control modules and control module pins.

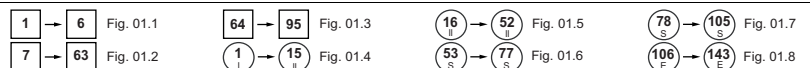
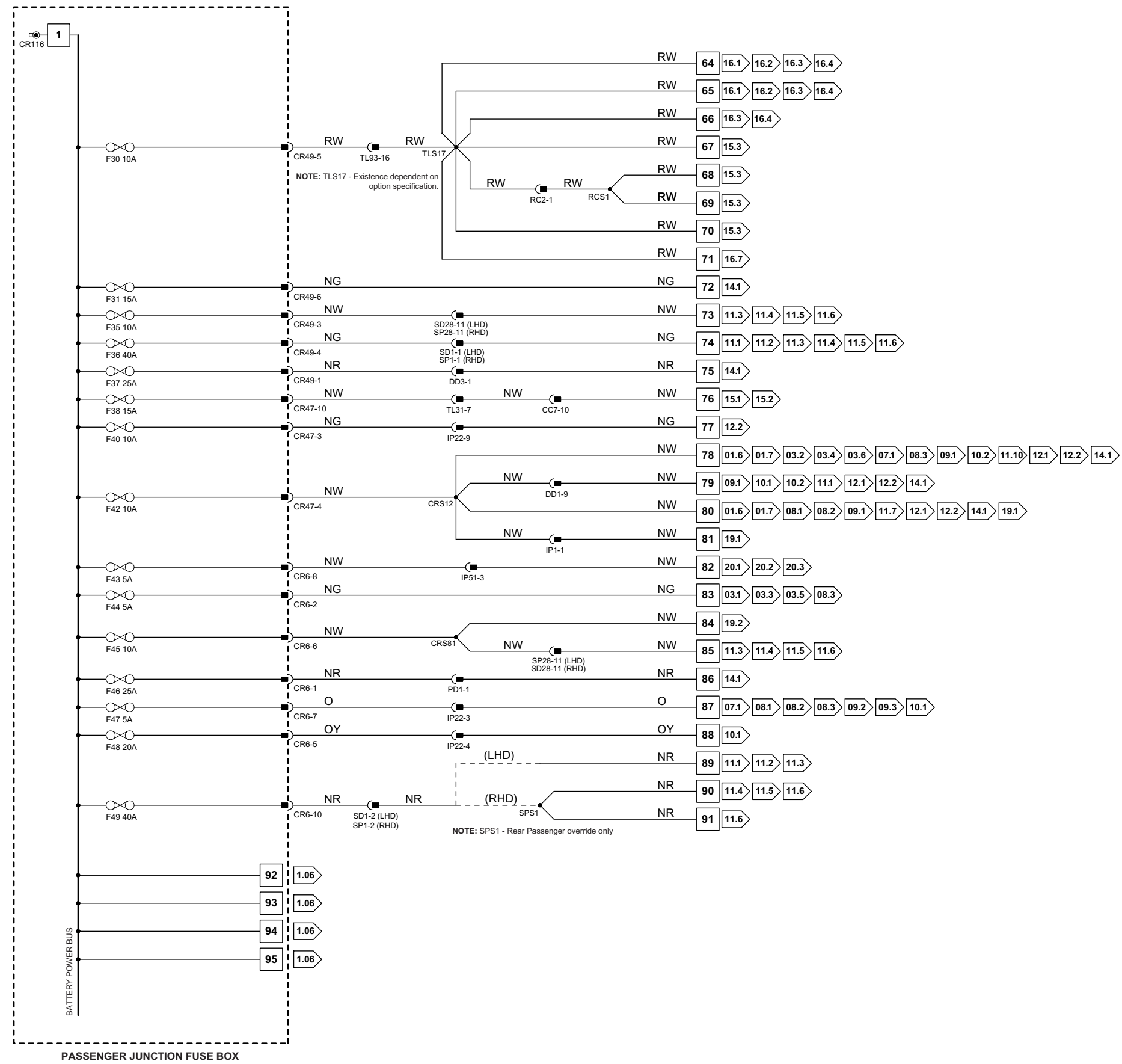

VARIANT: All Vehicles
 VIN RANGE: All
 DATE OF ISSUE: September 2004