



Sedan Range

DATE 4/96

09-01

SERVICE

TECHNICAL BULLETIN

Vehicle Vibration – Diagnosis

MODEL 1995 MY-ON
Sedan Range
VIN
720001 - ON

ISSUE:

Customer complaints of vibration on 1995 MY-ON Sedan Range vehicles within the above VIN range. This Technical Bulletin provides a guide to the diagnosis and repair of vibration problems.

ACTION:

In case of a customer complaint of vehicle vibration on 1995 MY-ON Sedan Range vehicles within the above VIN range, perform the following steps:

1. Obtain a copy of the Vibration Report Form S-95 from the parts department. Enter the VIN on the form.
2. Enter the customer's description of the condition on the back of the Vibration Report Form, S-95.
3. Perform a road test. After the road test, enter the results in the Road Test section on the back of the Report Form.

NOTE: The vehicle must be road tested to verify the customer complaint, to determine the type of vibration and when it occurs. The road test results must be recorded on the S-95 report form.

Fax the S-95 form to:

Product Investigation Department (201) 818-9763.

4. Perform a static inspection of the vehicle and enter the findings on the front of the report form. Inspect the wheels and tires for damage or excessive wear. Check the vehicle attitude. Repair, or replace as necessary, any defective components found.
5. If static inspection shows no faults, refer to the Vibration Diagnosis Chart on page 3 to determine repair.

ROADTEST

1. Drive the vehicle for at least 5 miles (8 km) at more than 50 mph (80 km/h) to remove any tire flat spots before attempting to evaluate the vibration condition.
2. Road test the vehicle at speeds within the same range in which the customer reported the vibration. Record the results in the RoadTest record column.
3. Check whether selecting Neutral or whether gear changes affect the vibration condition. If the condition does change, a static engine/powertrain test should be run to ascertain where the condition originates in the engine and transmission assembly.

STATIC INSPECTION

After confirming the customer complaint of vibration on the road test, check the following areas:

- a. Driveline/suspension fasteners and bushings (page 4).
- b. Transmission crossmember and transmission mount (page 5).
- c. Exhaust mounts and clearances.
- d. Vehicle attitude, which is measured vertically from the ground to the wheel opening lip, through the center line of the wheel. If rear of vehicle is low, refer to Technical Bulletin 64-16 dated 10/95.
- e. Alignment of paint spots on the final drive yoke and the drive shaft (page 8).
- f. Wheels and tires.

NOTE: Record the date code found on the tire side wall, for example, "DOT 275" (week 27, 1995).

SEDAN RANGE 1995 MY-ON - VIBRATION DIAGNOSIS

Vibration Range	Area And Frequency	Possible Cause	Confirmation/observation	Rectification
30 - 40 mph 50 - 65 km/h	Steering wheel	Final drive unit	Vibration increases on deceleration, without braking 40 - 30 mph (65 - 50 km/h)	See list B
45 - 55 mph 72 - 88 km/h	Steering wheel Floor Seat	Wheels and tires out of balance	Install a known good set of wheels and tires	See list A
45 - 55 mph 72 - 88 km/h	Steering wheel Floor Seat	Rear ride height and axle shaft angle	Vibration increases: 1) With additional load in rear 2) Under hard acceleration 3) On undulating roads	See list B
58 - 78 mph 93 - 120 km/h	Constant vibration - may reduce as tires warm up -	Short term flat spots	Allow 5 -10 miles (8 -16 km) warm-up before test	See list A
	or does not reduce as tires warm up	Permanent flat spots caused by long term parking	After test raise vehicle to avoid tire flat spotting	
75 mph 120 km/h and 110 - 125 mph 177 - 200 km/h (where permitted)	Phases in and out High frequency	Drive shaft alignment	-	See list B

List A Vibration caused by Wheels & Tires	List B Vibration caused by Driveline
<ul style="list-style-type: none"> • Check inflation pressures. Check for tire damage. Increase inflation pressures to 'high speed' setting. Retest. • Balance wheels and tires. Use 2-pc. balance weights to prevent altered balance caused by shifting of 1-pc. weights. (Technical Bulletin 04-15 Dated 8/94). Retest. • Release, rotate and reseal tires. Retest. • If a wheel and tire problem is still present, contact the tire supplier for technical support. • Advise customer that short term flat spotting is due to high nylon content of tires and is normal. 	<ul style="list-style-type: none"> • Check for increased vibration under load (see Technical Bulletin 64-16 Dated 10/95). • Check transmission mount (see page 5). If mount was adjusted, retest. • Check subframe bushings (see page 4). • Check drive shaft alignment (see page 6). If center bearing was adjusted, retest. • Detach drive shaft coupling and check pinion run-out, replace differential if over limit (see page 8). Retest. • Detach drive shaft coupling and rotate 120 deg. (see page 8). Retest. • Detach drive shaft coupling and rotate an additional 120 deg. Retest. • If no improvement, install new drive shaft. See Parts Information.

CHECKING REAR SUB FRAME BUSHINGS

Inspect the bushings in the mounting bracket and the subframe assembly (Illustration 1) for damage and distortion by checking that equal clearance exists at the top and at the bottom of the bushing.

A lack of clearance could indicate that the bushing has collapsed on the bump stop. Replace any damaged bushings and road test the vehicle before attempting further diagnosis.

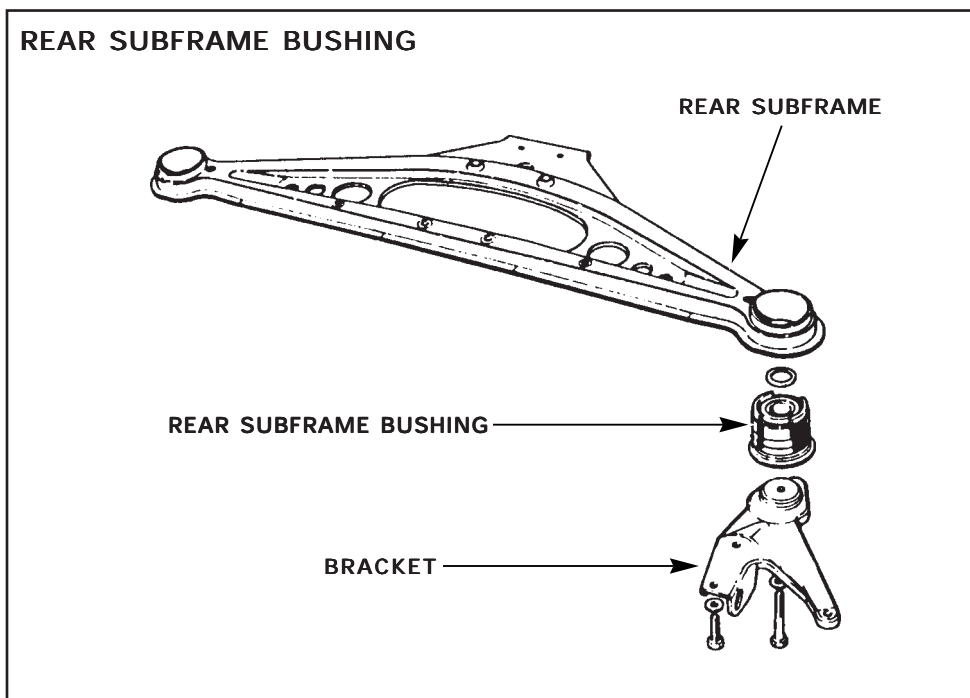

ILLUSTRATION 1

CHECKING TRANSMISSION MOUNT (CAST CROSSMEMBER ONLY)

Check by observing at the transmission mount bolt at the point shown in Illustration 2, that the transmission mount is centered in the crossmember.

If the rear mount appears to be offset, the crossmember can be repositioned by loosening the retaining bolts, and moving the crossmember until the mount is centered. Road test the vehicle to check for improvement.

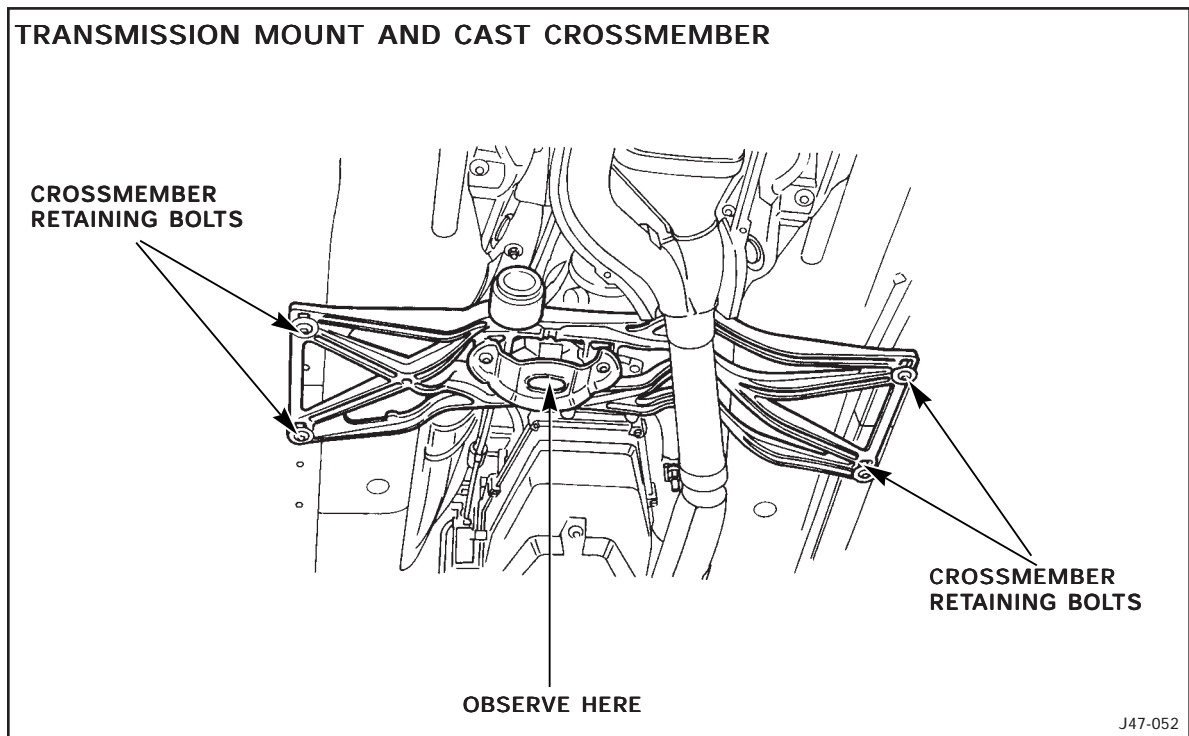

ILLUSTRATION 2

CHECKING DRIVE SHAFT ALIGNMENT

The outer edges of the shafts must be compared to check the alignment of the front and rear drive shaft centerlines. If necessary, the alignment of the drive shafts can be adjusted by moving the center bearing sideways.

1. Measure the drive shaft diameters at the points where the weights are shown suspended in Illustration 3 and subtract the smaller diameter from the larger diameter. Divide this number by 2 to determine the required offset.
2. Three separate 60" (1.5 m) lengths of plumb line with suitable weights at one end are required.

Wrap the three lines around the drive shaft so that all the lines hang from the same side of the drive shafts (Illustration 3) as follows:

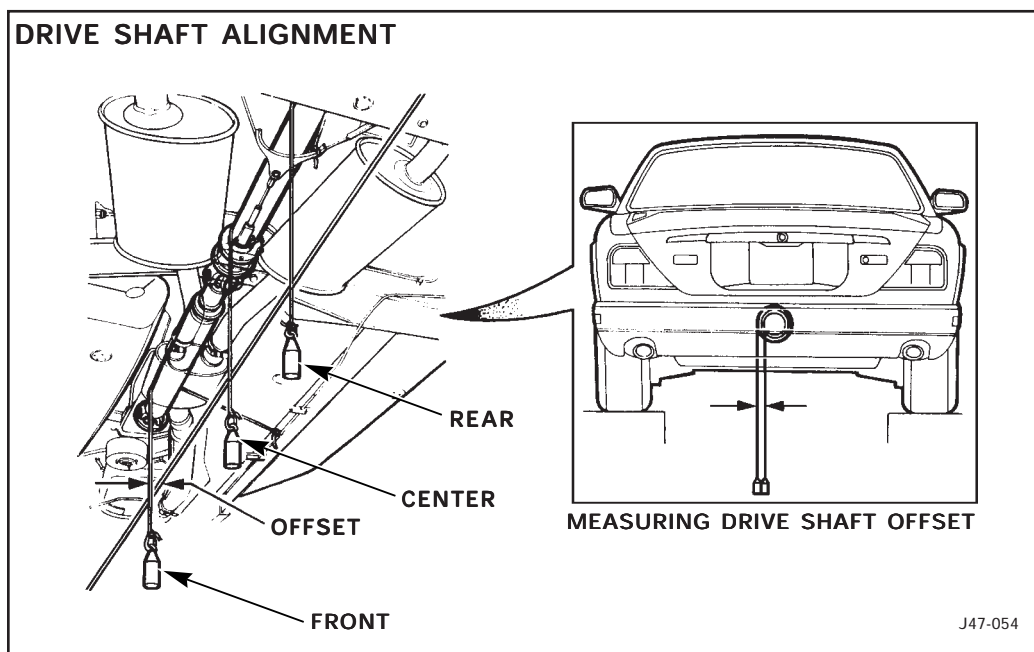

ILLUSTRATION 3

- Front - Behind the front universal joint.
- Center - Behind the center bearing.
- Rear - In front of the flexible coupling.

The lines should not cross balance weights or welds.

3. Once the lines and weights are hanging motionless from the drive shafts, an additional line should be stretched horizontally so it just contacts the two rear lines, and then held in this position.

NOTE: Use care to ensure that the vertical lines are not disturbed by the horizontal line.

4. Measure the distance from the front vertical line to the horizontal line (Illustration 3) to determine the drive shaft offset.

NOTE: The offset dimension must be recorded on the report form.

5. If the offset is not the same as the required offset value calculated on the previous page, the center bearing must be moved to correct the offset condition.

NOTE: Record the distance that the center bearing needs to be moved to correct its position (error dimension). This equates to the measured distance minus the calculated distance.

CENTER BEARING ADJUSTMENT

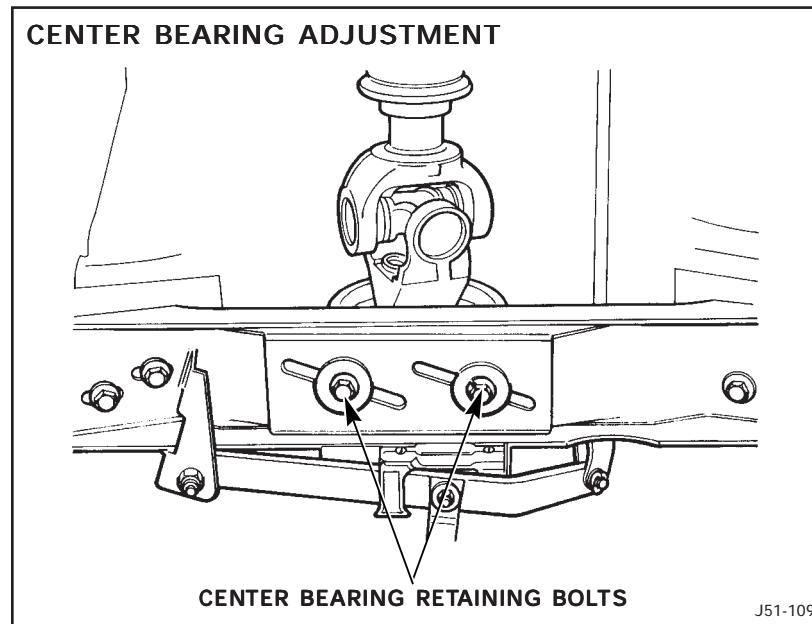

ILLUSTRATION 4

1. Loosen the two retaining bolts (illustration 4) until the center bearing and bracket are free to move.
2. Move the center bearing and bracket until the horizontal distance (offset) between the lines is the same as the required offset value calculated on the previous page.

CAUTION: Move the center bearing and bracket by hand only. Do not subject the center bearing and bracket to blows .

3. Tighten the bracket retaining bolts to 14.0-19.9 lb. ft. (19-27 Nm.) and then recheck the alignment/offset.
4. Remove the weights and lines and then road test the vehicle.

CHECKING THE PINION RUN-OUT & REPHASING THE DRIVE SHAFT COUPLING

The paint spots on one arm of the final drive pinion yoke and on the drive shaft must be aligned with each other to ensure optimum balance.

If a condition of imbalance is suspected, the flexible joint and the final drive pinion yoke can be rephased by 120 degrees and the vehicle road tested to check for an improvement.

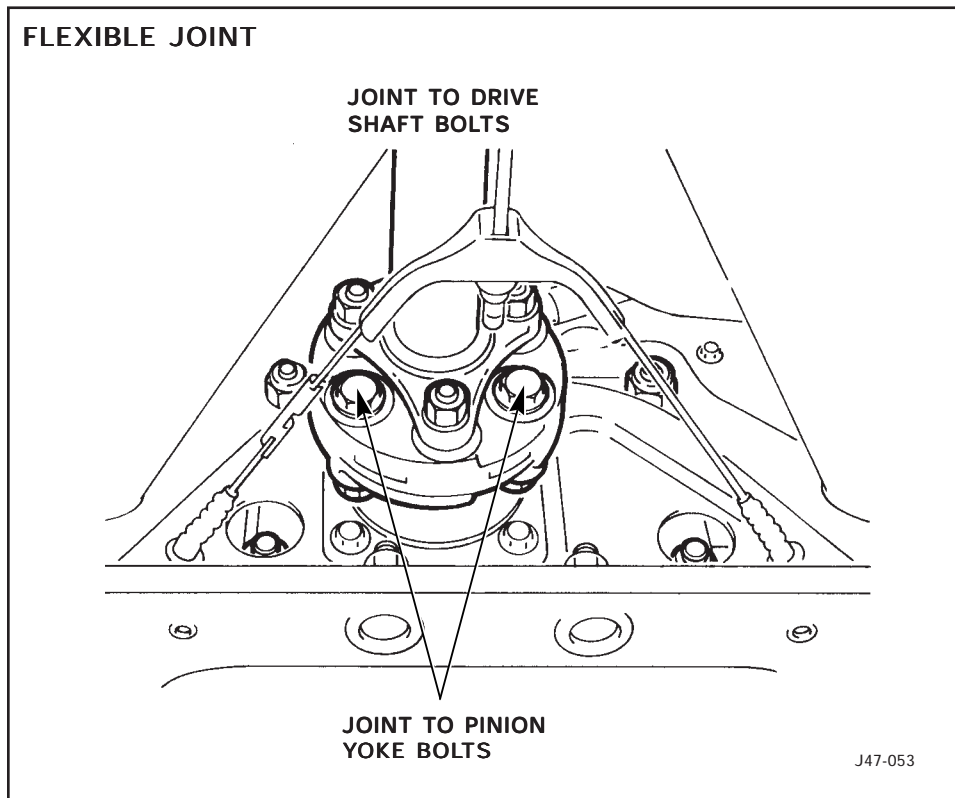

ILLUSTRATION 5

CAUTION: The flexible joint must never be separated from the drive shaft since the joint and drive shaft have been balanced as an assembly. Do not loosen the flexible joint to drive shaft retaining bolts and nuts (Illustration 5).

1. Ensure that the wheels are securely held and that the transmission selector is in the Neutral position.
2. Remove the three bolts (Illustration 5) retaining the flexible joint and drive shaft to the pinion yoke and then detach the joint from the yoke.
3. Raise a rear wheel to allow the pinion to rotate.
4. Remove and discard the retaining bolts from the drive shaft center bearing crossmember (Illustration 4), and lower the drive shaft and crossmember assembly to allow the drive shaft coupling to withdraw from the pinion nose.

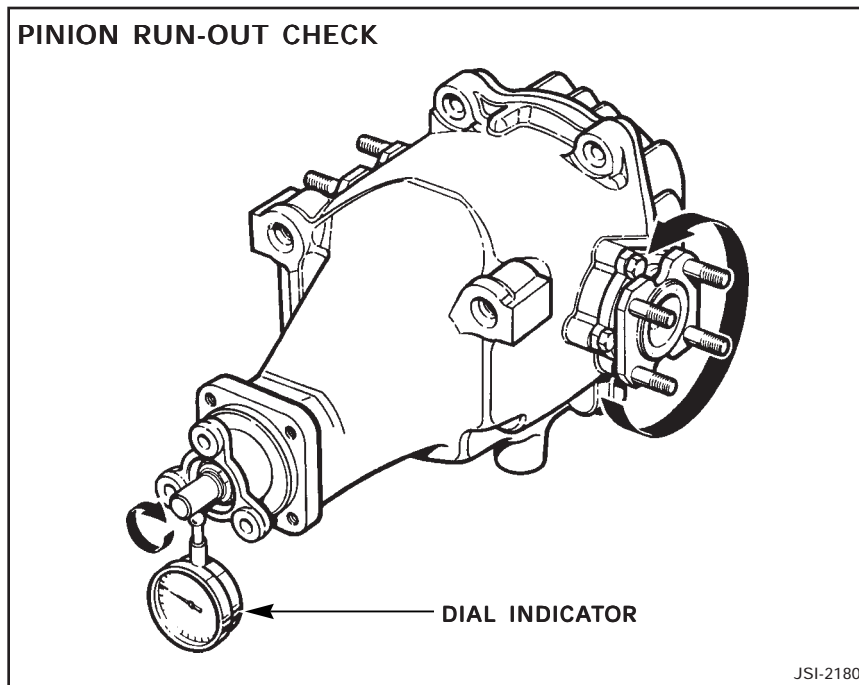

ILLUSTRATION 6

5. Mount a dial indicator to the final drive unit with the gauge stylus in contact with the pinion spigot, as shown in Illustration 6.
6. Carefully rotate the raised wheel to turn the pinion while noting the gauge reading.
7. If the gauge records a spigot run-out of greater than 0.003 in. (0.07 mm), the final drive unit must be replaced.
8. When reinstalling the drive shaft center bearing crossmember, use **NEW** retaining bolts.
9. Rotate the drive shaft 120 degrees in engine rotation from the paint spot on the final drive yoke, reinstall the drive shaft on the final drive yoke. Then install and torque the bolts to 52.4-61.2 lb. ft. (71-83 Nm.)
10. Recheck the drive shaft alignment and adjust if necessary. Road test the vehicle.
11. If the vehicle still exhibits vibration on the road test, rephase the drive shaft an additional 120 degrees in the direction of engine rotation relative to the pinon yoke.
12. Road test the vehicle. If the procedure still has not been successful, install a new drive shaft.

NOTE: Once the vibration condition is satisfactory, or if a new drive shaft is installed, install **NEW** nuts on the bolts retaining the flexible coupling to the drive flange.

PARTS INFORMATION:

<u>DESCRIPTION</u>	<u>PART NUMBER</u>	<u>QTY</u>
Drive shaft (4.0L NA exc LWB)	NBB 5800 FA	1
Drive shaft (4.0L SC)	NBD 5800 AA	1
Drive shaft (6.0L exc. LWB)	NAB 5800 AA	1
Drive shaft (6.0L LWB)	NBB 5800 FA	1
Nut, flex-joint to differential flange	NV 112051/J	3
Bolt, center bearing to crossmember	FS 108201/J	4
Final drive unit	as per fiche	1

WARRANTY INFORMATION:

<u>FAULT CODE</u>	<u>R.O. NUMBER</u>	<u>DESCRIPTION</u>	<u>TIME ALLOWANCE</u>
FS BB PQ	47.15.51	Check & reset drive shaft alignment (4.0L NA & SC)	0.15 hrs.
FS BB PQ	47.15.51	Check & reset drive shaft alignment (6.0L)	0.60 hrs.
FQ BD JC	47.91.04	Vibration check procedure (4.0L NA & SC) Final drive pinion check 1st drive shaft rephasing & alignment 2nd drive shaft rephasing	0.95 hrs.
FQ BD JC	47.91.04	Vibration check procedure (6.0L) Final drive pinion check 1st drive shaft index & alignment 2nd drive shaft index	1.40 hrs.
FS BB PQ	47.15.01	Drive shaft, replace (4.0L NA & SC)	1.00 hrs.
FS BB PQ	47.15.01	Drive shaft, replace (6.0L)	1.20 hrs.
FV DB PQ	51.25.13	Final drive, replace	6.05 hrs.
FQ BD JC	12.45.31	Rear transmission mount, adjust (4.0L NA)	0.15 hrs.