



SECTION CONTENTS

Sub-Section	Title	SRO	Page
A5.1	System Description		1
A5.2	Component Descriptions		3
A5.2.1	Central locking switch		3
A5.2.2	Door ajar switches		3
A5.2.3	Door lock actuator and switch		3
A5.2.4	Door lock switch		3
A5.2.5	Hood switch		3
A5.2.6	Horns		3
A5.2.7	Inclination sensor		4
A5.2.8	Intrusion sensor		4
A5.2.9	Reader exciter coil		4
A5.2.10	Reader exciter module		4
A5.2.11	Security active indicator		4
A5.2.12	Security and locking control module		4
A5.2.13	Siren		7
A5.2.14	Trunk lid release (external)		7
A5.2.15	Trunk lid release (internal)		7
A5.2.16	Valet switch		7
A5.3	General Information		7
A5.3.1	Locking		7
A5.3.2	Security system		8
A5.3.3	Convenience		8
A5.3.4	Alarms		8
A5.4	Key Fob Variations		9
A5.4.1	European and UK markets		9
A5.4.2	North American markets		10
A5.4.3	Rest of the world markets		11
A5.5	How to operate the system		12
A5.5.1	Locking (key)		12
A5.5.2	Unlocking (key)		12
A5.5.3	Locking / unlocking (key-ring transmitter)		13
A5.5.4	Locking (key-ring transmitter)		13
A5.5.5	Unlocking (key-ring transmitter)		14
A5.5.6	Panic feature (key-ring transmitter only)		14
A5.5.7	Central locking		15
A5.5.8	Passive arming		15
A5.5.9	Trunk release		15
A5.5.10	Trunk valet isolate		15
A5.5.11	Flush sill buttons		15
A5.15.6	System Diagnostic Methods		16





A5

Sub-Section	Title	SRO	Page
A5.7	System Testing		17
A5.7.1	Locking (key)		17
A5.7.2	Unlocking (key)		17
A5.7.3	Locking / unlocking (key–ring transmitter)		18
A5.7.4	Locking (key–ring transmitter)		18
A5.7.5	Unlocking (key–ring transmitter)		19
A5.7.6	Panic feature (key–ring transmitter only)		19
A5.7.7	Central locking		20
A5.7.8	Passive arming		20
A5.7.9	Trunk release		20
A5.7.10	Trunk valet isolate		20
A5.7.11	Flush sill buttons		20
A5.8	Diagnostic Sub–Routines		21
A5.9	Pin–point Tests		24
A5.9.1	Central locking switch		25
A5.9.2	Door ajar switches		26
A5.9.3	Door locks		27
A5.9.4	Door lock actuators and switch		28
A5.9.5	Hood switch		29
A5.9.6	Horns		30
A5.9.7	Inclination sensor		31
A5.9.8	Intrusion sensors		32
A5.9.9	Key barrel switches		33
A5.9.10	Reader exciter coil and module		34
A5.9.11	Security active indicator		35
A5.9.12	Sounder		36
A5.9.13	Trunk lid release actuator and relay		37
A5.9.14	Trunk lid release switches		38
A5.9.15	Valet switch		39
A5.10	Inclination Sensor – Renew	86.52.21	40
A5.11	Security and Locking Control Module (SLCM) – Renew	86.52.01	40
A5.12	Intrusion Sensor – Renew	86.52.20	41
A5.13	Hand Transmitter Battery – Renew	86.52.28	41
A5.14	Valet Switch – Renew	86.52.08	41
A5.15	Security Siren (12 Cyl) – Renew	86.52.03	42
A5.16	Security Siren (6 Cyl) – Renew	86.52.03	42
A5.17	Front Door Lock Assembly – Renew	86.25.45	43
A5.18	Rear Door Lock Assembly – Renew	86.25.47	44
A5.19	Trunk Lid Lock Actuator – Renew	86.25.49	44
A5.20	Clock Module – Renew	86.80.13	44
A5.21	Reader Exciter Coil and Module – Renew		44



A5.1 SYSTEM DESCRIPTION

The vehicle closures switching system comprises the security and central locking features applicable to that vehicle variant, as detailed in the table below. Central locking and security systems are controlled by a common electronic module designated as the Security and Locking Control Module (SLCM). The term closures refers to items which allow access to the vehicle interior and therefore must be closed when the vehicle is fully alarmed. These components are doors, windows, trunk, hood and sliding roof.

A5

	Method of Operation	UK / EUROPE			R O W			NORTH AMERICA		
		XJ16 / Sport	SOV / XJ12	DAIM / DD6	XJ16 / Sport	SOV / XJ12	DAIM / DD6	XJ16 / XJR	VDP	XJ12
Locking										
Central locking	Key	X	X	X	X	X	X	X	X	X
Remote central locking	Remote	X	X	X	X	X	X	X	X	X
Deadlocking	Remote / Key	X	X	X	X#	X#	X#	-	-	-
Two stage unlock	Remote / Key	-	-	-	-	-	-	X	X	X
Drive away locks	Auto	X / DD	X / DD	X / DD	X / DD	X / DD	X / DD	X / DD	X / DD	X / DD
Panic lock / unlock / all close	Switch	X	X	X	X	X	X	X	X	X
Interior trunk lid release	Switch	X	X	X	X	X	X	X	X	X
Flush sill buttons / intrusion override		X	X	X	X#	X#	X#	-	-	-
Security										
Security system (base)	Remote / Key	X	X	X	O	O	O	X	X	X
Intrusion sensing (full)	Auto	X	X	X	(X) 1/	(X) 1/	(X) 1/	-	-	-
Inclination sensing	Auto	D	D	D	D 2/	D 2/	D 2/	-	-	-
Passive arming	Remote	D	D	D	D 2/	D 2/	D 2/	-	-	-
Panic alarm	Remote	D	D	D	D 2/	D 2/	D 2/	-	-	-
Audible tones (error / deadlock)	Auto	X / DD	X / DD	X / DD	X / DD	X / DD	X / DD	X / DD	X / DD	X / DD
Engine immobilization	Auto	X	X	X	(X) 1/	(X) 1/	(X) 1/	-	-	-
Convenience										
All close	Key	X	X	X	X	X	X	X	X	X
Headlamp convenience	Remote	X	X	X	X	X	X	X	X	X
Trunk lid release	Remote	X	X	X	X	X	X	X	X	X
Trunk valet isolate	Switch	X	X	X	X	X	X	X	X	X
Driver seat memory select	Remote	(X) 3/	X	X	(X) 3/	X	X	(X) 3/	X	X
Intrusion sensing override	Switch	X	X	X	(X) 1/	(X) 1/	(X) 1/	-	-	-

Key	Notes
X = Standard	1/ Standard with security system
O = Factory option	2/ Only available with security option
D = Dealer option	3/ Standard only with power memory seats
DD = Dealer deletable	
- = Not available	
# = Except Japan (as NAS)	



Component Location Diagram

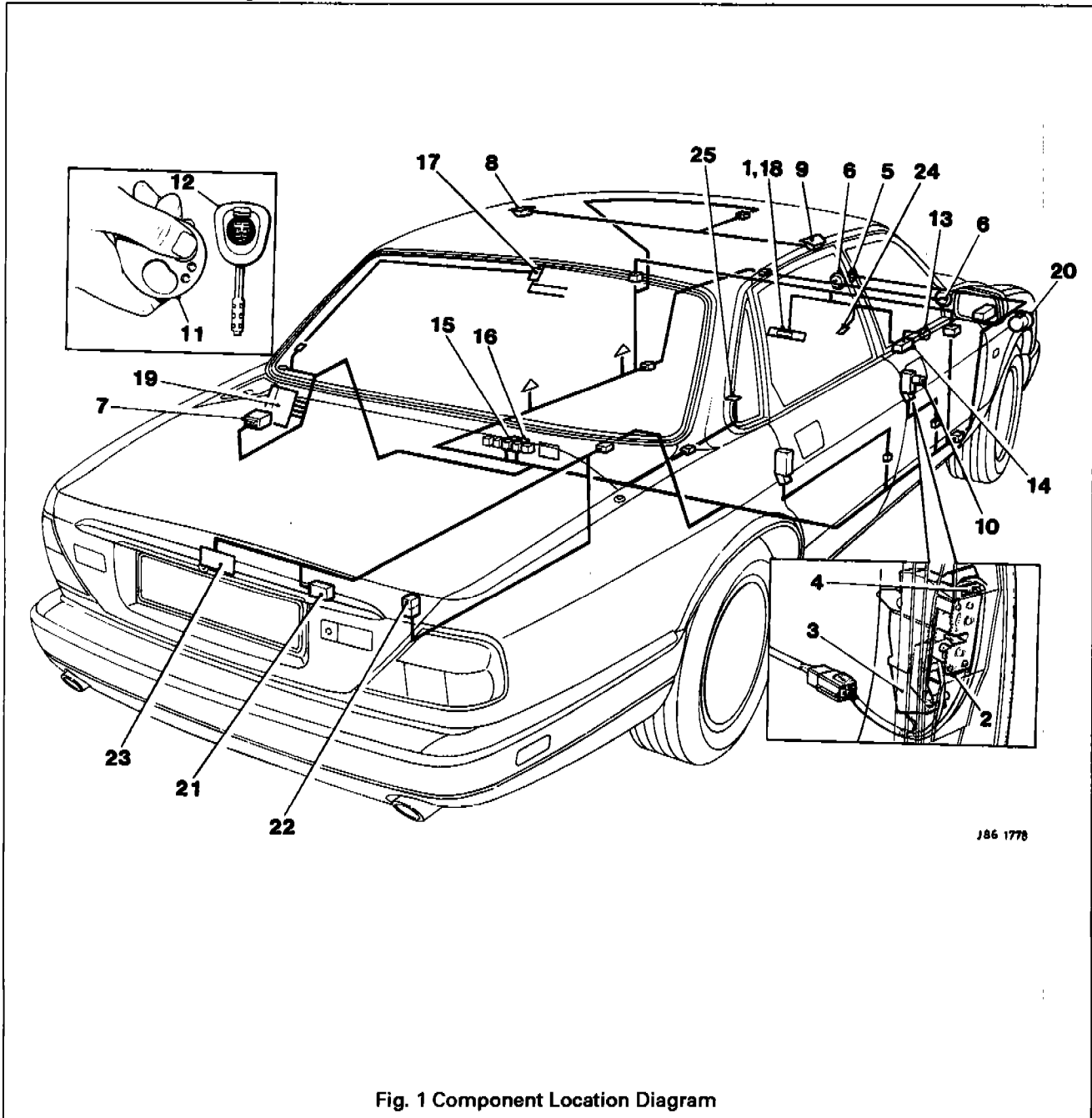



Key to Component Locations

Item No.	Description	Access details
01	Central locking switch	part of clock module
02	Door ajar switches (4 off)	part of door latch assembly
03	Door lock actuators (4 off)	part of door assembly
04	Door lock switches (2 off)	part of door latch assembly
05	Hood switch	located above siren
06	Horn	located on front RH side of engine bay
07	Inclination sensor	behind luggage compartment LH liner
08	Intrusion sensor (LH)	located above LH door behind roof lining
09	Intrusion sensor (RH)	located above LH door behind roof lining
10	Key barrel switches (2 off)	part of door latch assembly
11	Key fob transmitter	part of key fob
12	Key transponder	part of key
13	Reader exciter coil	part of ignition switch
14	Reader exciter module	part of steering column assembly
15	Relays (deadlock)	
16	Relays (door lock / unlock)	
17	Rear screen aerial	part of rear screen
18	Security active indicator	part of central locking switch
19	Security and locking control module (SLCM)	located in luggage compartment behind LH liner
20	Sounder	located on front RH side of engine bay
21	Trunk release actuator	located in trunk latch mechanism
22	Trunk release relay	
23	Trunk lid release switch (external)	part of trunk lid
24	Trunk lid release switch (internal)	part of fascia switchpack
25	Valet switch	in centre console compartment

A5

A5.2 COMPONENT DESCRIPTIONS

A5.2.1 Central locking switch

The central locking switch is located on the driver's fascia switchpack and allows locking / unlocking and all close from inside the vehicle when all doors are closed.

A5.2.2 Door ajar switches

Located in each front door lock mechanism to indicate door not closed correctly.

A5.2.3 Door lock actuator and switch

Located within each front door panel assembly to provide automatic lock / unlock operation.

A5.2.4 Door lock switch

Located in each front door lock mechanism to indicate door lock / unlock state.

A5.2.5 Hood switch

Located underhood adjacent to the horn to give indication of hood not closed correctly.

A5.2.6 Horns

Located adjacent to each headlight unit and utilized as part of the full alarm application.



A5.2.7 Inclination sensor

Located adjacent to the SLCM under the luggage compartment LH side liner to give indication of unauthorized jacking / lifting of the vehicle.

A5.2.8 Intrusion sensors

Located above each front door to give indication of unauthorized entry into the vehicle passenger compartment.

A5.2.9 Reader exciter coil

Forms an integral part of the ignition switch to prove correct key insertion by communicating key transponder signal to control module.

A5

A5.2.10 Reader exciter module

Located on the steering column to receive signals from the reader / exciter coil and disarm the engine immobilization system on correct demand.

A5.2.11 Security active indicator

An LED built into the central locking switch to indicate when security system is armed.

A5.2.12 Security and locking control module

Located in the luggage compartment below the LH side liner. Controls system operation and interface with associated modules to achieve correct response to input signals.

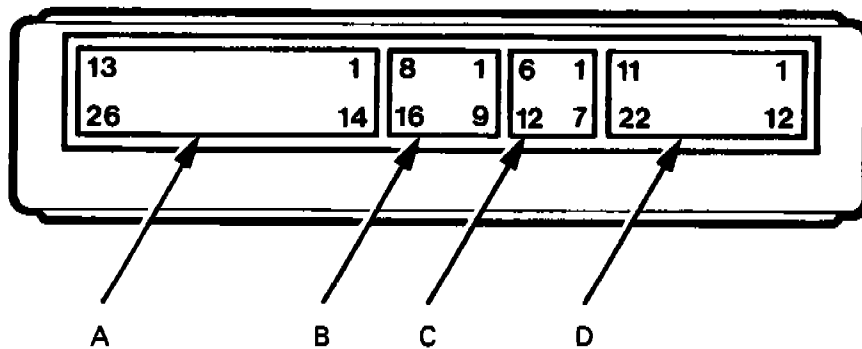

Fig.1 Control Module Connector Pins



Connections to the SLCM are detailed in the following table:

Connector A (26-way)

Pin No.	Signal	Description	Comment
01	O / P	Deadlock (front right / rear left)	switch to ground 200mA
02	O / P	Unlock driver's door	switch to ground 200mA
03			
04			
05	I / P	Vehicle speed	7600 pulses / mile
06	O / P	Inclination alarm	
07		Intelligent sounder	serial communications
08	O / P	Memory seat 2	switch to +12V for 500ms
09	O / P	Visual warning	switch to ground
10	O / P	Secure mode status	arm: 200Hz square wave \pm 5% disarm: 400Hz square wave \pm 5% duration: 64ms
11	O / P	Trunk lid release relay	switch to ground
12	I / P	Power +12V battery	+12V power supply
13	O / P	Sounder +ve	half of push pull network
14	O / P	Deadlock (front left / rear right)	switch to ground (200mA)
15	O / P	Lock relay	switch to ground (200mA)
16			
17			
18			
19	O / P	Alarm LED	switch to +12V (20mA)
20	O / P	Start inhibited	coded communication
21	O / P	Memory seat 1	switch to +12V for 500ms
22	O / P	All close	switch to ground
23	O / P	Interior lights on	switch to ground for 80ms \pm 5%
24	O / P	Horn relay	switch to ground (200ms)
25	I / P	Power ground	0V (nominal)
26	O / P	Sounder -ve	

A5

Connector B (16-way)

Pin No.	Signal	Description	Comment
01			
02		Intrusion sensor (RH)	ground screen
03	O / P	Intrusion sensor (RH)	40kHz
04	I / P	Intrusion sensor (RH)	signal
05	O / P	Intrusion sensor (RH)	+8V
06		Ground	
07		R.F. ground	
08		Diagnostic ISO K line	
09			
10		Intrusion sensor (LH)	ground
11	O / P	Intrusion sensor (LH)	40kHz
12	I / P	Intrusion sensor (LH)	signal
13	O / P	Intrusion sensor (LH)	+8V
14		Ground	
15	I / P	R.F. signal	
16		Diagnostic ISO L line	diagnostic link input



Connector C (12-way)

Pin No.	Signal	Description	Comment
01	I/P	Passenger door ajar	switch to ground
02	I/P	Trunk lid release external	switch to ground
03	I/P	Gearshift 'in-park' signal	not in-park = ground
04	I/P	Lock actuator status (RH)	switch to ground
05	I/P	Passenger door key unlock	switch to ground
06	I/P	Driver door key unlock	switch to ground
07	I/P	Driver door ajar	switch to ground
08	I/P	Ignition coil on (aux)	switch to ground
09	I/P	Transponder immobilization	data communications
10	I/P	Lock actuator status (LH)	switch to ground
11	I/P	Passenger door key lock	switch to ground
12	I/P	Driver door key lock	switch to ground

Connector D (22-way)

Pin No.	Signal	Description	Comment
01	O/P	Fuel filler flap lock	switch to ground 200mA
02			
03			
04			
05			
06	I/P	Trunk valet isolate switch	momentary switch to ground
07	I/P	Inclination alarm	
08	I/P	Trunk lid release (internal)	switch to ground
09	I/P	Hood open / ajar	switch to ground
10	I/P	Inertia switch	switch to ground
11	O/P	Transponder immobilization on	data communications
12	O/P	Memory seat remote indicator	switch to ground for 500ms
13	O/P	Headlight convenience	switch to ground for 25 seconds
14			
15			
16			
17	I/P	Ignition on	switch to ground
18	I/P	Ignition key in	switch to ground
19	I/P	Central locking switch	switch to ground
20	I/P	Trunk lid ajar	switch to ground
21	I/P	Rear doors ajar	switch to ground
22	O/P	Unlock relay	switch to ground (200mA)



A5.2.13 Siren

Located on the RH side at the front of the engine bay to provide audible alarm signals.

A5.2.14 Trunk lid release (external)

Located in trunk lid for conventional key access to luggage compartment.

A5.2.15 Trunk lid release (internal)

Located on fascia switchpack to allow lid release from driving position.

A5.2.16 Valet switch

Located in the central column compartment to allow securing of luggage compartment independently of other facilities.



A5.3 GENERAL INFORMATION

The following information details the purpose and function of the system components irrespective of individual variant features.

A5.3.1 Locking:

Central locking

A traditional central locking application, such that when the driver's / passenger's door is locked / unlocked using the door key all four doors lock / unlock simultaneously.

Note: Locking operations will only take place when all doors are completely closed.

Remote central locking

Automatic locking / unlocking, activated by the larger of the two key fob buttons.

Note: Locking operations will only take place when all doors are completely closed.

Deadlocking

A means of securing door locks so that they cannot be opened using the interior release mechanism, and arming the security sensing system, using the door key or remote transmitter

Two-stage unlocking

A key / remote operated unlocking procedure which releases driver's door and fuel filler cap locks only, initially, and then releases all other doors and the luggage compartment locks.

Drive-away locks

Automatic locking of all doors, and luggage compartment (but not fuel filler cap), when gear selector is moved away from 'Park' and the ignition switch is in position II, providing all doors are closed.

Central lock / unlock, all close

Automatic locking of all doors and luggage compartment by operation of the fascia mounted central locking switch. Continued switch operation causes closure of sliding roof and open windows.

Interior trunk lid release

Trunk lid unlocking from fascia mounted switch.

Flush sill buttons / intrusion override

Sill buttons fitted flush to door trim panel to prevent unauthorized override operation, buttons are latched in position when deadlocking is applied.



A5.3.2 Security system

Base system

Provides standard vehicle arming, ie door ajar, actuator lock status, trunk lid or hood ajar and passenger door unlocking, does not include inclination or

Intrusion sensing

Detection of intrusion into the passenger compartment by removal or breakage of any glazed area, entry via any protected enclosure and unauthorized door opening detection.

Inclination (tilt) sensing

Detection of unauthorized jacking / towing.

Passive arming

Arming of the security system, excluding intrusion sensors, without audible confirmation.

Audible tones

Audible indication of driver error when attempting to arm the system, or on initiation of deadlocking.

Engine immobilization

Automatic immobilization of the engine crank facility whenever the ignition key is turned to position 0.

A5.3.3 Convenience

All close

Automatic closure of open windows and sliding roof by prolonged action of key, or remote fob transmitter after door locking.

Headlamp convenience

Automatic illumination of headlamps for driver convenience on operation of key fob button after locking sequence completed.

Remote trunk lid release

Automatic release of the trunk lid lock on operation of the smaller key fob button after door unlocking.

Trunk valet isolate

Independent locking of the trunk lid to eliminate unauthorized entry to the luggage compartment.

Driver seat memory select

Automatic recall of a memorized driving position on operation of the smaller key fob button.

Intrusion sensing override

Allows intrusion sensing to be disabled until the next disarm action.

A5.3.4 Alarms

There are eight possible alarm activation modes; driver's door, hood, ignition key in (ignition auxiliary position, ignition ON), inclination, inner door handle action (causing actuator status switches to operate), intrusion, passenger door and trunk.

Any of the above conditions occurring after the vehicle is fully armed will cause full alarm state.

Any of the above conditions, except door opening, occurring after the vehicle is fully armed and active disarming is selected will cause full alarm state. Door opening after active disarming selection will give a 30 second audible tick period before full alarm is entered.

Any of the above conditions occurring after the vehicle has been passively armed will give a 30 second audible tick period before full alarm is entered.

Activation of full alarm state causes sidelights, direction indicators, interior lights or headlamps to flash (dependant upon market variations), the security sounder to operate and the vehicle horns to operate (if programmed to do so).

An error tone is generated if active arming is selected with either hood or trunk open, or the transmitter is pressed with ignition key in auxiliary position.





A5.4 KEY FOB VARIATIONS

Due to the varying applications for different world markets, three types of key locking (local and remote) have been developed. The following tables detail these variations:

A5.4.1 European & UK markets (variant 1)

DOOR LOCKING				
Action	Device operation			Function
	Key	Remote signal transmitter		
		Large button	Small button	
Lock and arm (perimeter only)	Turn to lock position and release	1st press	N / A	Locks all doors, trunk and fuel filler cap. Arms alarm system.
Lock, arm (perimeter only) and all-close	Turn to lock position and hold for 2 seconds	Continued hold of 1st press for 2 seconds	N / A	Locks all doors, trunk lid and fuel filler cap. Arms alarm system. Key only; closes open windows and sliding roof in 1.5 seconds.
Deadlock (perimeter, inclination, intrusion) and all-close	Turn to unlock, then lock within three seconds; hold in lock for all close	2nd press and hold for 2 seconds	N / A	Deadlocks all doors, locks trunk lid and fuel filler cap and arms alarm system immediately. Closes windows and sliding roof after 1.5 seconds.
Headlamps ON for 25 seconds	N / A	3rd press (1st press if button not operated within the last 4 seconds)	N / A	Switches headlights on for driver convenience.

A5

Note: If key is turned to lock position with vehicle already locked / deadlocked, all-close will be activated.

DOOR UNLOCKING				
Action	Device operation			Function
	Key	Large button	Small button	
Unlock	Turn to unlock position and release	N / A	1st press	Unlocks doors, trunk lid (key only) and fuel filler cap. Disarms alarm system, except for 30 second audible tick. Turns on interior lights for 15 seconds. Remote button only; cancels trunk valet lock-out and recalls memorised driving position.
Trunk lid release	N / A	N / A	2nd press (within 10 seconds of previous action)	Trunk lid release
Remote panic	N / A	N / A	3 second press	Unlocks, disarms and enters full alarm state ie audible alarm (both sounder and horn) and visual alarm (flashing lights).



A5.4.2 North American markets (variant 2)

DOOR LOCKING				
Action	Device operation	Remote signal transmitter		Function
		Key	Large button	
Lock and arm (perimeter only)	Turn to lock position and release	1st press	N / A	Locks all doors, trunk and fuel filler cap. Arms alarm system.
Lock, arm (perimeter only) and all-close	Turn to lock position and hold for 2 seconds	Continued hold of 1st press for 2 seconds	N / A	Locks all doors, trunk lid and fuel filler cap. Arms alarm system. Key only; closes open windows and sliding roof in 1.5 seconds.
Headlamps ON for 25 seconds	N / A	2nd press (1st press if vehicle is locked and armed)	N / A	Switches headlights on for driver convenience.

DOOR UNLOCKING				
Action	Device operation	Remote signal transmitter		Function
		Key	Large button	
Unlock (driver's door only)	Turn to unlock position and release	N / A	1st press	Unlocks driver's door, and fuel filler cap. Disarms alarm system. Turns on interior lights for 15 seconds. Remote button only; cancels trunk valet lock-out and recalls memorised driving position.
Unlock (all doors)	Either turn to unlock and hold for 2 seconds or perform a second unlock action	N / A	2nd press	Unlocks all other doors, key only; unlocks trunk lid.
Trunk lid release	N / A	N / A	3rd press (press to be within 10 seconds of previous action)	Trunk lid lock release
Remote panic	N / A	N / A	3 second press	Unlocks, disarms and enters full alarm state ie audible alarm (both sounder and horn) and visual alarm (flashing lights).



A5.4.3 Rest of the World (variant 3)

DOOR LOCKING				
Action	Device operation			Function
	Key	Remote signal transmitter		
		Large button	Small button	
Lock and arm (perimeter, inclination, intrusion)	Turn to lock position and release	1st press	N / A	Locks all doors, trunk and fuel filler cap. Arms alarm system.
Lock, arm (perimeter, inclination, intrusion) and all-close	Turn to lock position and hold for 2 seconds	Continued hold of 1st press for 2 seconds	N / A	Locks all doors, trunk lid and fuel filler cap. Arms alarm system. Key only; closes open windows and sliding roof in 1.5 seconds.
Headlamps ON for 25 seconds	N / A	2nd press; within 10 seconds of first with vehicle unlocked, disarmed (1st press if vehicle is locked and armed)	N / A	Switches headlights on for driver convenience.

A5

DOOR UNLOCKING				
Action	Device operation			Function
Unlock	Turn to unlock position and release	N / A	1st press	Unlocks all doors, trunk lid (key only) and fuel filler cap. Disarms alarm system. Turns on interior lights for 15 seconds. Remote button only; cancels trunk valet lock-out and recalls memorised driving position.
Trunk lid release	N / A	N / A	2nd press (press to be within 10 seconds of previous action)	Trunk lid lock release.
Remote panic	N / A	N / A	3 second press	Unlocks, disarms and enters full alarm state ie audible alarm (both sounder and horn) and visual alarm (flashing lights).



A5.5 HOW TO OPERATE THE SYSTEM

Locking, unlocking and setting the vehicle alarm system is carried out by key or by radio frequency key-ring transmitter.

Operation of the system by key or key-ring transmitter will be described separately in this sub-section.

Key-ring transmitter functions vary slightly between market variants. The action for each variant is described separately where appropriate

Note: Certain functions differ due to market variations. Differences will be detailed in the the following instruction tables. The variants are defined as follows:

- Variant 1 – European and UK markets
- Variant 2 – North American markets
- Variant 3 – Rest of the World.

A5

A5.5.1 Locking (key)

Instruction	Variant 1	Variant 2	Variant 3
Turn key to lock position and release.	Lock all doors, trunk lid, fuel filler cap and arm the alarm system (perimeter only).	Lock all doors, trunk lid, fuel filler cap and arm the alarm system.	Lock all doors, trunk lid, fuel filler cap and arm the alarm system (perimeter only) alarms.
Turn key to lock position, hold for 2 seconds and release.	Lock all doors, trunk lid, fuel filler cap. Arm the alarm system (perimeter only). Close open windows and sliding roof.	Lock all doors, trunk lid, fuel filler cap. Arm the alarm system. Close open windows and sliding roof.	Lock all doors, trunk lid, fuel filler cap. Arm the alarm system (perimeter only). Close open windows and sliding roof.
Turn key to unlock position and then to lock position within 3 seconds. Hold in lock position for 2 seconds to close windows and sliding roof.	Deadlock all doors, lock trunk lid and fuel filler cap. Arm the alarm system (perimeter, inclination and intrusion). Close open windows and sliding roof. Once deadlocking is completed, the sounder gives one audible tone.	No feature	Deadlock all doors, lock trunk lid and fuel filler cap. Arm the alarm system (perimeter, inclination and intrusion). Close open windows and sliding roof. Once deadlocking is completed, the sounder gives one audible tone. Note: No deadlock feature in Japanese market.

A5.5.2 Unlocking (key)

Instruction	Variant 1	Variant 2	Variant 3
Turn key to unlock position and release.	Unlock all doors, trunk lid, fuel filler cap. On variant 1 unlocking with the key does not disarm the alarm system. An audible ticking indicates that the alarm will activate after 30 seconds unless the key is turned to position II in the ignition or the key-ring transmitter button (small) is pressed.	Unlock drivers door only, trunk lid, fuel filler cap. Disarm the alarm system. Switch on the interior light for 15 seconds.	Unlock all doors, trunk lid, fuel filler cap. Disarm the alarm system. Switch on the interior light for 15 seconds.
Turn key to unlock position and hold for 2 seconds.	No feature	Unlock all other doors and trunk lid.	No feature



A5.5.3 Locking / Unlocking (Key-ring Transmitter)

Each vehicle is supplied with two radio frequency transmitters, designed to be attached to the drivers key-ring. Key-ring transmitter 1 is dedicated to driving position memory 1 and key-ring transmitter 2 is dedicated to driving position memory 2.

The key-ring transmitter is activated by pointing it towards the vehicle and pressing one of the two operating buttons; the large button locks the vehicle and arms the alarm system, whilst the small button unlocks the vehicle and disarms the alarm system. When either one of the buttons are pressed, an indicator light on the key-ring transmitter flashes; red for the large button, green for the small button.

If the ignition key is left in the ignition switch the following features will be inhibited:

- Alarm system
- Remote luggage compartment release.

If the ignition key is left in the ignition switch in position 1 the remote headlamp convenience feature will be inhibited.

Note: Locking is inhibited if any door is open or ajar.



A5.5.4 Locking (Key-ring Transmitter)

Instruction	Variant 1	Variant 2	Variant 3
Press large button once.	Lock all doors, trunk lid, fuel filler cap and arm the alarm system (perimeter only). Direction indicators flash once. Warning light (central locking switches) flashes when vehicle secured.	Lock all doors, trunk lid, fuel filler cap and arm the alarm system (perimeter, inclination and intrusion alarms). An audible signal will be heard and side lights will flash once. Warning light (central locking switches) flashes when vehicle secured. Headlamps on for 25 seconds if vehicle previously locked and armed.	Lock all doors, trunk lid, fuel filler cap and arm the alarm system (perimeter only). Direction indicators flash once. Warning light (central locking switches) flashes when vehicle secured. Headlamps on for 25 seconds if vehicle previously locked and armed. Japanese Market Only: Lock all doors, trunk lid, fuel filler cap and arm the alarm system. Headlamps on for 25 seconds if vehicle previously locked and armed.
Press large button again within 3 seconds of first press.	Deadlock all doors, Arm the alarm system (perimeter, inclination and intrusion).	Headlamps on for 25 seconds.	Deadlock all doors, Arm the alarm system (perimeter, inclination and intrusion). Japanese Market Only: Headlamps on for 25 seconds.
Press large button for third time within ten seconds of previous action.	Headlamps on for 25 seconds. Note: The headlamps will also come on if the large button is pressed whenever the vehicle is locked or deadlocked.	No Feature.	Headlamps on for 25 seconds. Japanese Market Only: No Feature.



A5.5.5 Unlocking (Key-ring Transmitter)

Instruction	Variant 1	Variant 2	Variant 3
Press small button once (vehicle locked and armed).	Unlocks all doors, trunk lid, fuel filler cap. Disarms the alarm system and switch on interior light for 15 seconds. Cancels luggage compartment valet lock-out, if set. Recalls the memory position of the driver's seat, steering column and door rear view mirrors. Two audible signals will be heard and the direction indicator will flash twice during the unlocking / disarming process.	Unlocks drivers door only, trunk lid, fuel filler cap. Disarms the alarm system and switch on interior light for 15 seconds. Cancels luggage compartment valet lock-out, if set. Recalls the memory position of the driver's seat, steering column and door rear view mirrors. Two audible signals will be heard and the direction indicator will flash twice during the unlocking / disarming process.	Unlocks all doors, trunk lid, fuel filler cap. Disarms the alarm system and switch on interior light for 15 seconds. Cancels luggage compartment valet lock-out, if set. Recalls the memory position of the driver's seat, steering column and door rear view mirrors. Two audible signals will be heard and the direction indicator will flash twice during the unlocking / disarming process. Japanese Market Only: No audible or visual indication of unlocking / disarming.
Press small button again.	Releases luggage compartment. Button must be pressed within ten seconds of first press.	Unlocks all passenger doors.	Releases luggage compartment. Button must be pressed within ten seconds of first press.
Press small button again.	No feature	Releases luggage compartment. Button must be pressed within ten seconds of first press.	No feature

Note: The sounder gives a short, high-pitched warble every time a button on the key-ring transmitter is pressed, whenever on of the following conditions is present:

- The trunk lid or hood is not properly closed when an attempt to arm the security system is made.
- The ignition key is in the ignition switch
- If there is a failure within the security system.

A5.5.6 Panic Feature (Key-ring Transmitter Only)

When in or near the vehicle, the alarm can be set off to deter a would-be offender. This feature will also unlock the doors and fuel filler flap. For this feature to operate, the ignition key must not be in position 'I' or 'II'.

The panic alarm will sound for five times the normal full alarm period. The alarm can only be stopped by turning the ignition key to position 'I' or 'II'. The key-ring transmitter can not be used to cancel the panic alarm.

To operate the panic alarm:

- Variants 1 and 3, press and hold the small button for 3 seconds.
- Variant 2, press and hold either the small or large buttons for 3 seconds.

Note: The panic alarm can be operated at any time during the locking or unlocking procedure, regardless of the state of the locking / security system.



A5.5.7 Central Locking

Note: The following lock conditions are inhibited when any door is open or ajar.

The central locking switch is mounted on the fascia. With the ignition switch in either position 'I' or 'II', press the central locking switch to lock all the doors and the luggage compartment, if they are unlocked.

Hold down the switch for 3 seconds to close any open windows or the sliding roof.

A further press on the central locking switch after 3 seconds will unlock the doors and the luggage compartment.

If the switch is pressed when ignition switch is not in position I or II, tilt and intrusion sensing will be disabled until the next arming action. The active indicator, mounted in the switch housing, will flash to confirm this action.

A5.5.8 Passive Arming

Passive arming is a dealer option on variants 1 and 3.

Passive arming of the vehicle, if the feature has been activated, takes place 30 seconds after the last closure of the doors, trunk lid, hood or sliding roof. For passive arming to take place the ignition switch must be in the 'OFF' position.

When passive arming occurs, the direction indicators flash once, the red warning light in the central locking switch lights for 2 seconds the flashes once the vehicle is armed.

Note: There is no audible indication when passive arming occurs.

To disarm a passively armed vehicle the ignition key or key-ring transmitter can be used as follows:

- Ignition key – Switch to position 'II'.
- Key-ring transmitter – Refer to A5.3.5 *Unlocking*.

A5.5.9 Trunk Release

The trunk lid can be released in the following ways:

- From the vehicle interior by pressing the trunk release switch mounted on the fascia.
- By using the ignition key in the trunk lid if the vehicle is disarmed. If not disarmed the the alarm system will be activated and can be switched off by ignition key or key-ring transmitter.
- Remotely (as part of the unlocking procedure) by the key-ring transmitter.

A5.5.10 Trunk Valet Isolate

A valet switch is located in the centre console compartment and is fitted on all variants.

The switch is provided to prevent unauthorized entry into the luggage compartment by a parking attendant by inhibiting the luggage compartment remote release switch.

The green headed valet key can be used to park and lock the vehicle but does not unlock the luggage compartment.

A5.5.11 Flush Sill Buttons

Variants 1 and 3 (except Japanese market) are fitted with flush sill buttons mounted in the door trim panel.

To lock the door from the interior press the sill button down, flush with the door trim panel. To unlock the door pull the door lever out.





A5.6 SYSTEM DIAGNOSTIC METHODS

The following information details diagnostic procedures for system fault identification using a Portable Diagnostic Unit (PDU).

PDU is designed and supplied by Jaguar Cars Ltd. to interrogate the electronic control circuitry of the various vehicle systems, diagnose fault conditions and indicate to the operator recorded faults and possible remedies. On initiation of diagnostic procedures PDU will display the model variant and control module type, a list of enabled functions can also be accessed. Ensure that this information is correct for the vehicle under test, ie that the correct module is fitted and all appropriate options are enabled.

Detailed information on testing using PDU is detailed in the support documentation supplied with the unit.

A5



A5.7 SYSTEM TESTING

The following information details the procedures for a complete system test to identify and locate possible fault conditions. Where faulty operation is identified refer to Diagnostic Sub-Routines for possible causes and remedies.

Locking, unlocking and setting the vehicle alarm system is carried out by key or by radio frequency key-ring transmitter.

Note: Ensure all doors are fully closed before initiating lock procedures.

Key-ring transmitter functions vary slightly between market variants. The action for each variant is described separately where appropriate

Note: Certain functions differ due to market variations. Differences will be detailed in the the following instruction tables. The variants are defined as follows:

- Variant 1 – European and UK markets.
- Variant 2 – North American markets.
- Variant 3 – Rest of the World.



A5.7.1 Locking (key)

Instruction	Variant 1	Variant 2	Variant 3
Turn key to lock position and release.	Check that all doors, trunk lid and fuel filler cap lock and that the alarm system (perimeter only).arms.		
Turn key to lock position, hold for 2 seconds and release.	Check that all doors, trunk lid and fuel filler cap lock, the alarm system (perimeter only) arms and all open windows and sliding roof close within 1.5 seconds.		
Turn key to unlock position and then to lock position within 3 seconds. Hold in lock position for 2 seconds to close windows and sliding roof.	<p>Check all doors are deadlocked and trunk lid and fuel filler cap are locked. Check alarm system (perimeter, inclination and intrusion) arms and all open windows and sliding roof close within 1.5 seconds.</p> <p>Ensure that once deadlocking is completed, the sounder gives one audible tone.</p>	No feature	<p>Check all doors are deadlocked and trunk lid and fuel filler cap are locked. Check alarm system (perimeter, inclination and intrusion) arms and all open windows and sliding roof close within 1.5 seconds.</p> <p>Ensure that once deadlocking is completed, the sounder gives one audible tone.</p> <p>Note: No deadlock feature in Japanese market.</p>

A5.7.2 Unlocking (key)

Instruction	Variant 1	Variant 2	Variant 3
Turn key to unlock position and release.	<p>Check all doors, trunk lid and fuel filler cap unlock.</p> <p>On variant 1 unlocking with the key does not disarm the alarm system. An audible ticking indicates that the alarm will activate after 30 seconds unless the key is turned to position II in the ignition or the key-ring transmitter button (small) is pressed.</p>	<p>Check drivers door and fuel filler cap unlock. Check that the alarm system disarms and the interior light illuminates for 15 seconds.</p>	<p>Check all doors, trunk lid and fuel filler cap. Check that the alarm system disarms and the interior light illuminates for 15 seconds.</p>
Turn key to unlock position and hold for 2 seconds.	No feature	Check all passenger doors and trunk lid lock.	No feature



A5.7.3 Locking / Unlocking (Key-ring Transmitter)

Each vehicle is supplied with two radio frequency transmitters, designed to be attached to the drivers key-ring. Key-ring transmitter 1 is dedicated to driving position memory 1 and key-ring transmitter 2 is dedicated to driving position memory 2.

The key-ring transmitter is activated by pointing it towards the vehicle and pressing one of the two operating buttons; the large button locks the vehicle and arms the alarm system, whilst the small button unlocks the vehicle and disarms the alarm system. When either one of the buttons are pressed, an indicator light on the key-ring transmitter flashes; red for the large button, green for the small button.

If the ignition key is left in the ignition switch the following features will be inhibited:

- Alarm system
- Remote luggage compartment release.

If the ignition key is left in the ignition switch in position 1 the remote headlamp convenience feature will be inhibited.

A5.7.4 Locking (Key-ring Transmitter)

Instruction	Variant 1	Variant 2	Variant 3
Press large button once.	<p>Check all doors, trunk lid and fuel filler cap lock and the alarm system (perimeter only) arms.</p> <p>Ensure direction indicators flash once and the security active indicator flashes when vehicle secured.</p> <p>Check that headlamps are illuminated for 25 seconds if vehicle was previously locked and armed and button has not been pressed within 4 seconds.</p>	<p>Check all doors, trunk lid and fuel filler cap lock and the alarm system arms.</p> <p>Ensure that an audible signal is heard, side lights flash once. and security active indicator flashes when vehicle secured.</p> <p>Check that headlamps are illuminated for 25 seconds if vehicle was previously locked and armed.</p>	<p>Check all doors, trunk lid and fuel filler cap lock and the alarm system (perimeter only) arms.</p> <p>Ensure direction indicators flash once. and security active indicator flashes when vehicle secured.</p> <p>Check that headlamps are illuminated for 25 seconds if vehicle was previously locked and armed.</p> <p>Japanese Market Only:</p> <p>Check all doors, trunk lid and fuel filler cap lock and the alarm system arms.</p> <p>Check that headlamps illuminate for 25 seconds if vehicle was previously locked and armed.</p>
Press large button again within 3 seconds of first press.	<p>Check all doors are deadlocked and the alarm system (perimeter, inclination and intrusion) is armed.</p>	<p>Check headlamps illuminate for 25 seconds.</p>	<p>Check all doors are deadlocked and the alarm system (perimeter, inclination and intrusion) is armed.</p> <p>Japanese Market Only:</p> <p>Check headlamps illuminate for 25 seconds.</p>
Press large button for third time within ten seconds of previous action.	<p>Check headlamps illuminate for 25 seconds.</p> <p>Note:</p> <p>The headlamps will also illuminate if the large button is pressed whenever the vehicle is locked or deadlocked.</p>	<p>No Feature.</p>	<p>Check headlamps illuminate for 25 seconds.</p> <p>Japanese Market Only:</p> <p>No Feature.</p>



A5.7.5 Unlocking (Key-ring Transmitter)

Instruction	Variant 1	Variant 2	Variant 3
Press small button once (vehicle locked and armed).	<p>Check all doors, trunk lid and fuel filler cap unlock. Check that the alarm system disarms and the interior light illuminates for 15 seconds.</p> <p>Check luggage compartment valet lock-out is cancelled, if set.</p> <p>Ensure the memory position of the driver's seat, steering column and door rear view mirrors is restored.</p> <p>Check that two audible signals are heard and the direction indicator flashes twice during the unlocking / disarming process.</p>		<p>Japanese Market Only: No audible or visual indication of unlocking / disarming.</p>
Press small button again	Check luggage compartment released when button pressed within ten seconds of first press.	Check all passenger doors unlocked.	Check luggage compartment released when button pressed within 10 seconds of first press.
Press small button again	No feature	Check luggage compartment released when button pressed within 10 seconds of second press.	No feature.

A5

Check that the sounder gives a short, high-pitched warble every time a button on the key-ring transmitter is pressed, whenever one of the following conditions is present:

- The trunk lid or hood is not properly closed when an attempt to arm the security system is made.
- The ignition key is in the ignition switch
- If there is a failure within the security system.

A5.7.6 Panic Feature (Key-ring Transmitter Only)

Ensure the ignition key is not in position 'I' or 'II' and check panic alarm as follows.

To operate the panic alarm:

- Variants 1 and 3, press and hold the small button for 3 seconds.
- Variant 2, press and hold either the small or large buttons for 3 seconds.

Ensure that the panic alarm sounds for five times the normal full alarm period and the alarm can only be stopped by turning the ignition key to position 'I' or 'II' ie the key-ring transmitter can not be used to cancel the panic alarm. Check that the alarm unlocks the doors and fuel filler flap.

Note: The panic alarm can be operated at any time during the locking or unlocking procedure, regardless of the state of the locking / security system.



A5.7.7 Central Locking

Note: Ensure all doors are fully closed before commencing lock operations.

With the ignition switch in either position 'I' or 'II', press the central locking switch and check that all the doors and the luggage compartment lock, if they are unlocked.

Hold down the switch for 3 seconds and check any open windows or the sliding roof close, if open.

Check that a further press on the central locking switch after 3 seconds will unlock the doors and the luggage compartment.

If the switch is pressed when ignition switch is not in position I or II, tilt and intrusion sensing will be disabled until the next arming action. The active indicator, mounted in the switch housing, will flash to confirm this action.

To disarm a passively armed vehicle the ignition key or key-ring transmitter can be used as follows:

- Ignition key – Switch to position 'II'.
- Key-ring transmitter – Refer to A5.3.5 *Unlocking*.

A5.7.8 Passive Arming

Passive arming is a dealer option on variants 1 and 3 only.

With the ignition switch in the OFF position, check that passive arming of the vehicle takes place 30 seconds after the last closure of the doors, trunk lid, hood or sliding roof.

Ensure that when passive arming occurs, the direction indicators flash once and the security active indicator in the central locking switch lights for 2 seconds then flashes once when vehicle arming is complete.

Note: There is no audible indication when passive arming occurs.

A5.7.9 Trunk Release

Check that the the trunk lid can be released in the following ways:

- From the vehicle interior by pressing the trunk release switch mounted on the fascia.
- By using the ignition key in the trunk lid if the vehicle is disarmed. If not disarmed the the alarm system will be activated and can be switched off by ignition key or key-ring transmitter.
- Remotely (as part of the unlocking procedure) by the key-ring transmitter.

A5.7.10 Trunk Valet Isolate

Check that valet switch operation prevents unauthorized entry into the luggage compartment by inhibiting the luggage compartment remote release switch and the green headed valet key can be used to park and lock the vehicle but does not unlock the luggage compartment.

A5.7.11 Flush Sill Buttons

Variants 1 and 3 (except Japanese market) are fitted with flush sill buttons mounted in the door trim panel. Check button operation as follows:

To lock the door from the interior press the sill button down, flush with the door trim panel. To unlock the door pull the door lever out.

A5



A5.8 *DIAGNOSTIC SUB-ROUTINES*

The following information details possible remedies to faults identified in the system during the system test. For detailed testing of individual components refer to section A5.9, *Pin Point Tests*.

Fault: **System will not lock / and arm**

- Possible causes:**
1. Transmitter battery faulty (remote operation only)
 2. Rear screen aerial cable damaged / disconnected (remote operation only).
 3. No power supply to SLCM.
 4. Wiring harness or connectors faulty.

- Remedy:**
1. Renew battery, refer to section A58.
 2. Identify and repair aerial cable fault.
 3. Check fuse F4 in trunk fuse box.
 4. Check harness and connectors from SLCM. Repair or renew as necessary.



Fault: **All Close facility only inoperative or faulty**

- Possible causes:**
1. Faulty components in sliding roof or window systems.
 2. Damaged harness wiring between SLCM and Sliding Roof Control Module (SRCM) and Body Processor Unit (BPU).

- Remedy:**
1. Refer to Section 15.7 Closures.
 2. Examine and repair or renew faulty harness.

Fault: **Door locking / unlocking facility inoperative or faulty**

- Possible causes:**
1. No power supply to lock relays.
 2. Door lock / unlock relays faulty.
 3. Door actuators faulty.
 4. Keylock switches faulty.
 5. Deadlock circuitry faulty.
 6. Wiring harness or connectors faulty.

- Remedy:**
1. Check fuse F1 in RH 'A' post base fusebox.
 2. Renew faulty relay.
 3. Renew door lock assembly complete.
 4. Renew door lock assembly complete.
 5. See Deadlock fault Sub-Routine.
 6. Examine and repair or renew faulty harness.

Fault: **Deadlocking facility inoperative or faulty (not NAS)**

- Possible causes:**
1. No power supply to deadlock relays.
 2. Deadlock relays faulty.
 3. Deadlock status micro-switch faulty.

- Remedy:**
1. Check fuse F1 in RH 'A' post base fusebox.
 2. Renew faulty relay.
 3. Renew doorlock assembly complete.



A5

Fault: **Intrusion sensing inoperative**
Possible causes:
1. Faulty sensor.
2. Harness wiring or connectors faulty.
Remedy:
1. Renew sensor.
2. Examine and repair or renew faulty harness.

Fault: **Inclination sensing inoperative**
Possible causes:
1. Faulty sensor.
2. Harness wiring or connectors faulty.
Remedy:
1. Renew sensor.
2. Examine and repair or renew faulty harness.

Fault: **Fuel filler cap locking / unlocking faulty**
Possible causes:
1. No power to actuator relay.
2. Wiring harness or connectors faulty
3. Relay faulty
4. Actuator faulty.
Remedy:
1. Check fuse F1 in RH 'A' post fuse box.
2. Examine and repair or renew faulty harness.
3. Renew relay.
4. Renew actuator.

Fault: **Panic feature inoperative**
Possible causes:
1. Transmitter battery inoperative.
2. Rear screen aerial cable damaged / disconnected.
Remedy:
1. Renew battery.
2. Identify and repair aerial fault.

Fault: **Central locking switch inoperative**
Possible causes:
1. Harness wiring or connectors faulty.
2. Switch faulty.
Remedy:
1. Examine and repair or renew damaged harness.
2. Renew switch.



Fault: Trunk lid locking / unlocking faulty

Possible causes:

1. No power to actuator relay.
2. Wiring harness or connectors faulty
3. Relay faulty
4. Actuator faulty.
5. Switch faulty.

Remedy:

1. Check fuse F8 in trunk fuse box.
2. Examine and repair or renew faulty harness.
3. Renew relay.
4. Renew actuator.
5. Renew switch.

Fault: Valet isolate facility inoperative

Possible causes:

1. Faulty switch
2. Harness wiring or connectors faulty.

Remedy:

1. Renew switch.
2. Examine and repair or renew faulty harness.

Fault: Sill buttons inoperative

Possible causes:

1. Mechanical failure
2. Door microswitch faulty.

Remedy:

1. Refer to VSM.
2. Renew door lock assembly complete.

Fault: Memory position selection inoperative

Possible causes:

1. Transmitter battery inoperative.
2. Rear screen aerial cable damaged / disconnected.
3. Memory switch pack faulty

Remedy:

1. Renew battery.
2. Identify and repair aerial cable fault.
3. Refer to Section 15.4.

Note: For door, hood and trunk ajar fault diagnosis refer to Section 15.2



A5.9 PIN-POINT TESTS

The following information details test procedures to identify specific component faults.

The table below provides a key to items identified on the following schematic diagrams.

Item No.	Description	Item No.	Description
1	Security / Locking Control Module	21	Hood switch
2	Central locking switch	22	LH Engine bay fuse-box
3	Front passenger door ajar switch	23	Horn relay
4	RH rear passenger door ajar switch	24	Horn unit LH
5	LH rear passenger door ajar switch	25	Horn unit RH
6	Driver's door ajar switch	26	Horn switches
7	Driver's door lock switch	27	Inclination sensor
8	Passenger's door lock switch	28	Intrusion sensor LH
9	Driver's door unlock relay (NAS only)	29	Intrusion sensor RH
10	Non-deadlock shorting links (NAS only)	30	Passenger door key barrel switch
11	Front left / rear right deadlock relay	31	Driver's door key barrel switch
12	Front right / rear left deadlock relay	32	Reader exciter module
13	Door lock relay	33	Reader exciter coil
14	Door unlock relay	34	Trunk fuse-box
15	LH Rear door actuator and switch	35	Security active indicator
16	RH Rear door actuator and switch	36	Security sounder
17	Front door actuator lock / deadlock status switches	37	Trunk release relay
18	Driver's door actuator lock / deadlock status switches	38	Trunk release actuator
19	Driver's door unlock shorting link	39	Trunk release switch (fascia)
20	RH 'A' post base fuse-box	40	Trunk release switch
		41	Valet switch



A5.9.1 Central locking switch

1. Check continuity from 22-way multi-plug pin 19 to ground, open circuit should be recorded.
2. Operate switch and check that short circuit to ground is now present.
3. Check wiring continuity from 22-way multi-plug pin 19 to switch connector pin 3.
4. Check wiring continuity from switch connector pin 1 to ground.

Note: If switch is faulty the whole clock module must be renewed; refer to sub-section 15.9.10.

A5

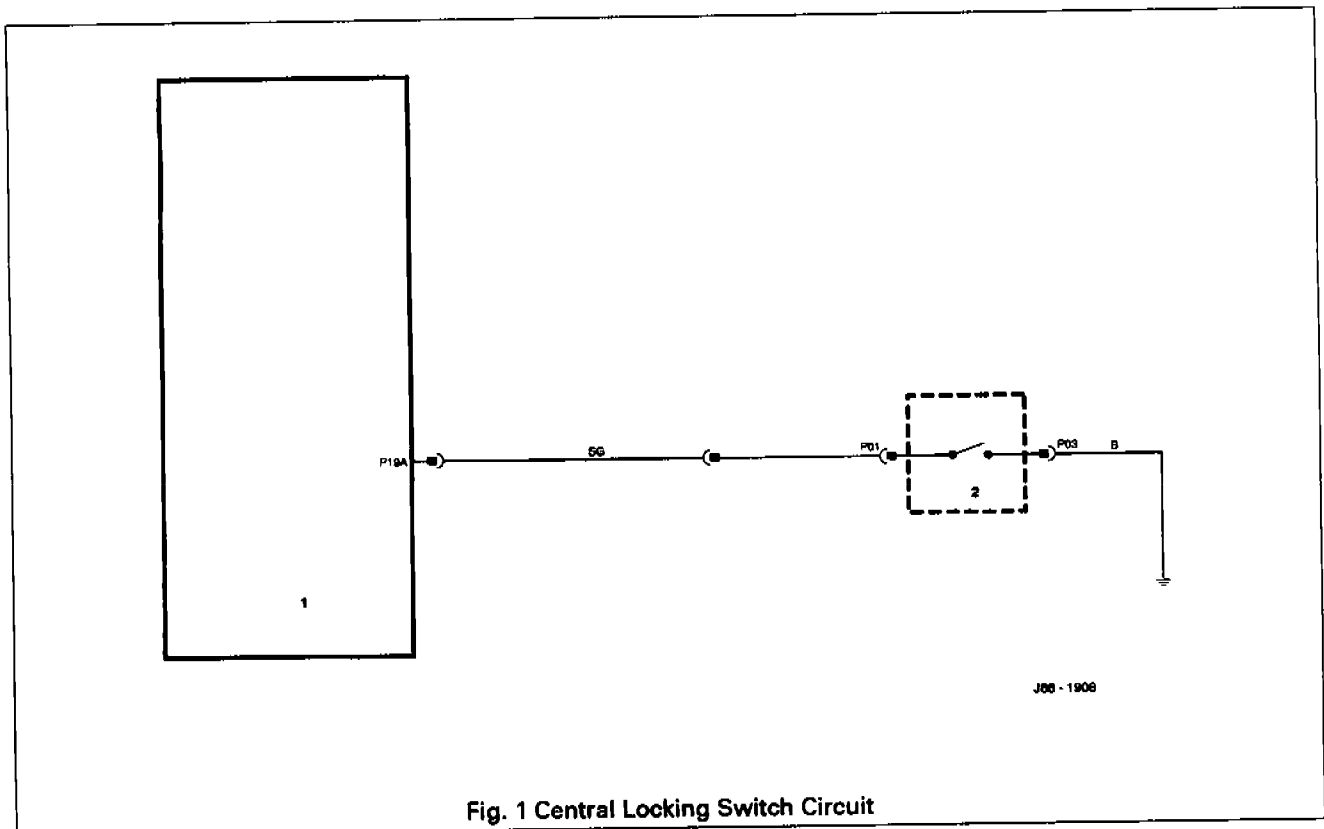



A5.9.2 Door ajar switches

1. Close all four doors and turn ignition to ON.
2. Open each door in turn, checking that instrument pack indicator lamp illuminates at every opening action.
3. On identification of non-illumination check continuity across suspect door switch, door closed – switch open circuit, door open switch short circuit.
4. If switches test correctly check wiring continuity between SLCM connector and switches, then to ground as detailed below



Door	SLCM	Switch	Ground
Driver's	Pin 07, 12-way	Pin 06	Pin 07
Passenger's (front)	Pin 01, 16-way	Pin 06	Pin 06
Passenger's (rear)	Pin 21, 22-way	Pin 05	Pin 06

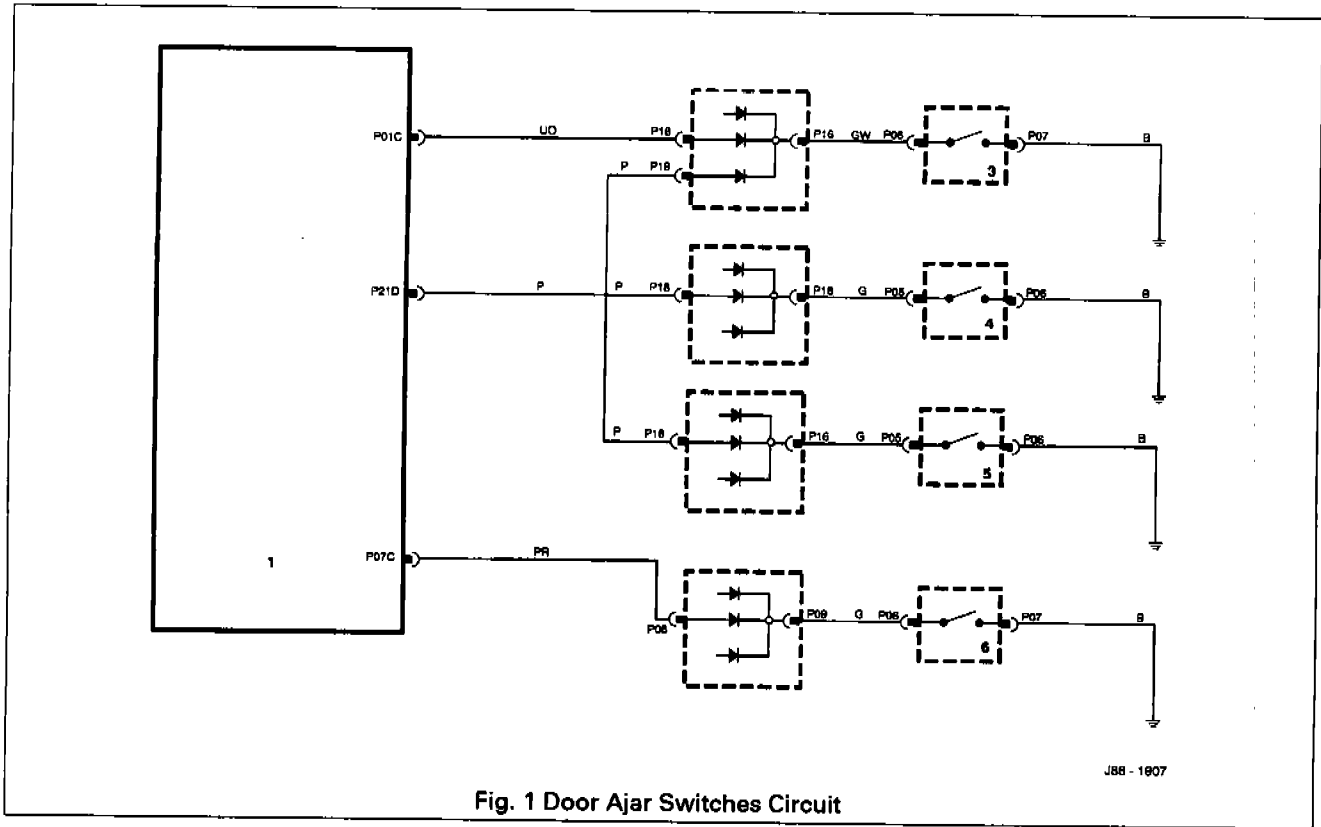



A5.9.3 Door locks

1. Check harness wiring continuity between multi-plug 12-way connector pins 10 (driver's side) and 4 (passenger's side) to respective door lock connector pin 8. Ensure secure ground connection from each lock connector pin 9.
2. Test continuity across switch pins, reading should be open circuit with door unlocked, short circuit with door locked.

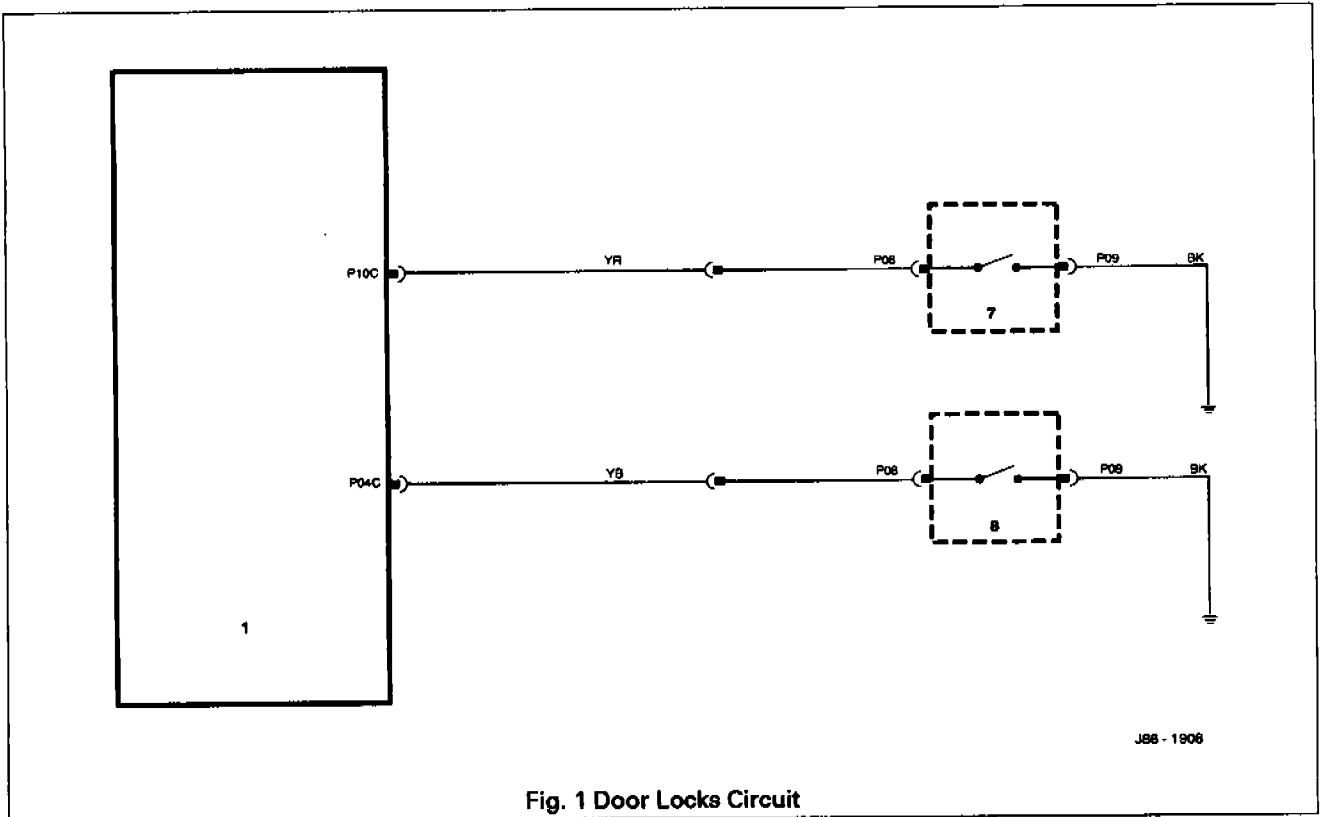

A5

Fig. 1 Door Locks Circuit



A5.9.4 Door lock actuators and switch

1. Examine fuse F1 in right hand 'A' post base fusebox, if blown determine reason for rupture and renew.
2. Check continuity of harness wiring as shown on Fig. 1 below. Ensure secure ground connection from lock / unlock and deadlock (not N.A.S.) relay pins 4 and 9.
3. Remove the left hand rear seat hell board, gaining access to lock / unlock and deadlock (not N.A.S.) relays. Operate lock / unlock and deadlock checking for audible relay operation. renew suspect relays.
4. Release door lock and measure resistance between actuator unit pins 2 and 3, a value of approximately 8Ω should be recorded. Operate door lock and check that circuit between pins 2 and 3 is opened. Resistance across pins 1 and 3 should now be approximately 8Ω.

A5

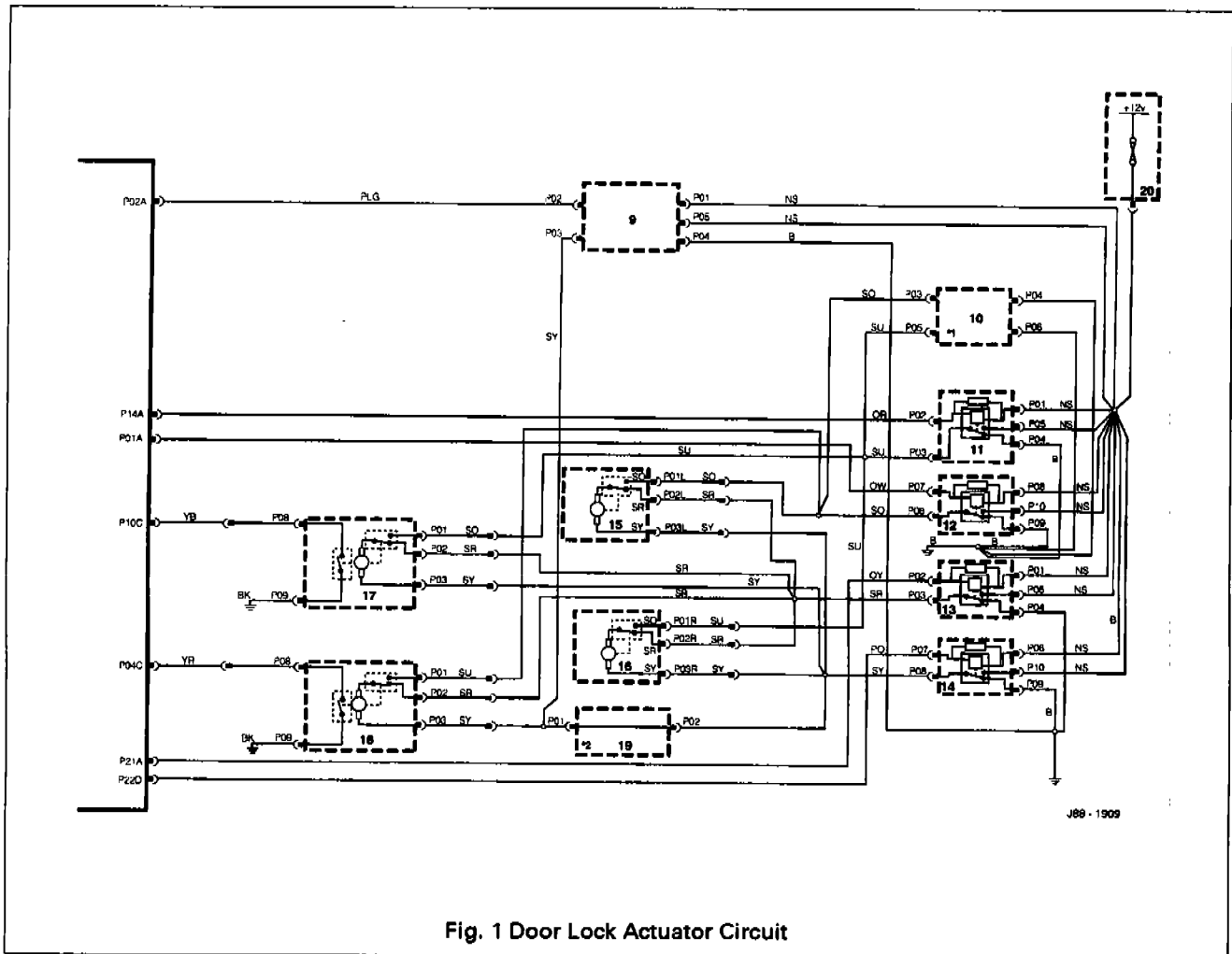

Fig. 1 Door Lock Actuator Circuit

*1 N.A.S. only

*2 Not N.A.S.



A5.9.5 Hood Switch

1. Check continuity between SLCM 22-way connector pin 9 and ground. With hood closed open circuit should be recorded, with hood open short circuit to ground should be recorded.
2. Check wiring continuity from pin 9 to switch connector pin 1, and from switch connector pin 2 to ground.

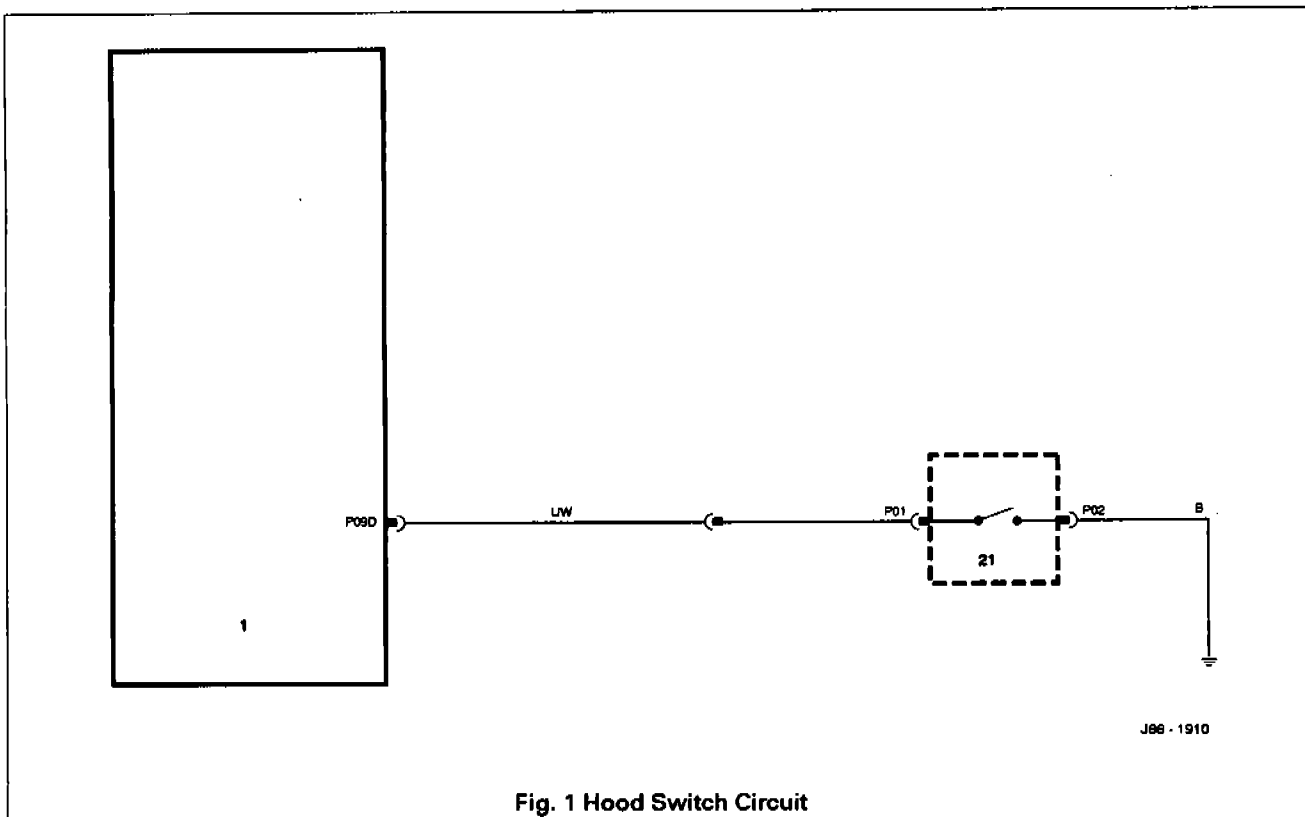

A5

Fig. 1 Hood Switch Circuit



A5.9.6 Horns

1. Check fuses F10 and F14 in LH engine bay fuse box; if blown determine reason for rupture and renew.
2. Check wiring harness continuity from multi-plug 26-way connector pin 24 to relay unit connector pin 6 and column switchgear connector pin 16. Ensure secure ground connection from column switchgear connector pin 7.

Check wiring harness continuity from fuse connector pins 7 and 8 to LH and RH horn respectively. Ensure secure ground connection from both horn units.

3. Ensure that +12V (nominal) is present at the relay connector pin.
4. Operate horn switches and check that +12V (nominal) is present at the two fuse connector pins and at speaker connector pin 44 (both units).

Check resistance across speaker unit pins; a value of approximately 2Ω should be recorded.

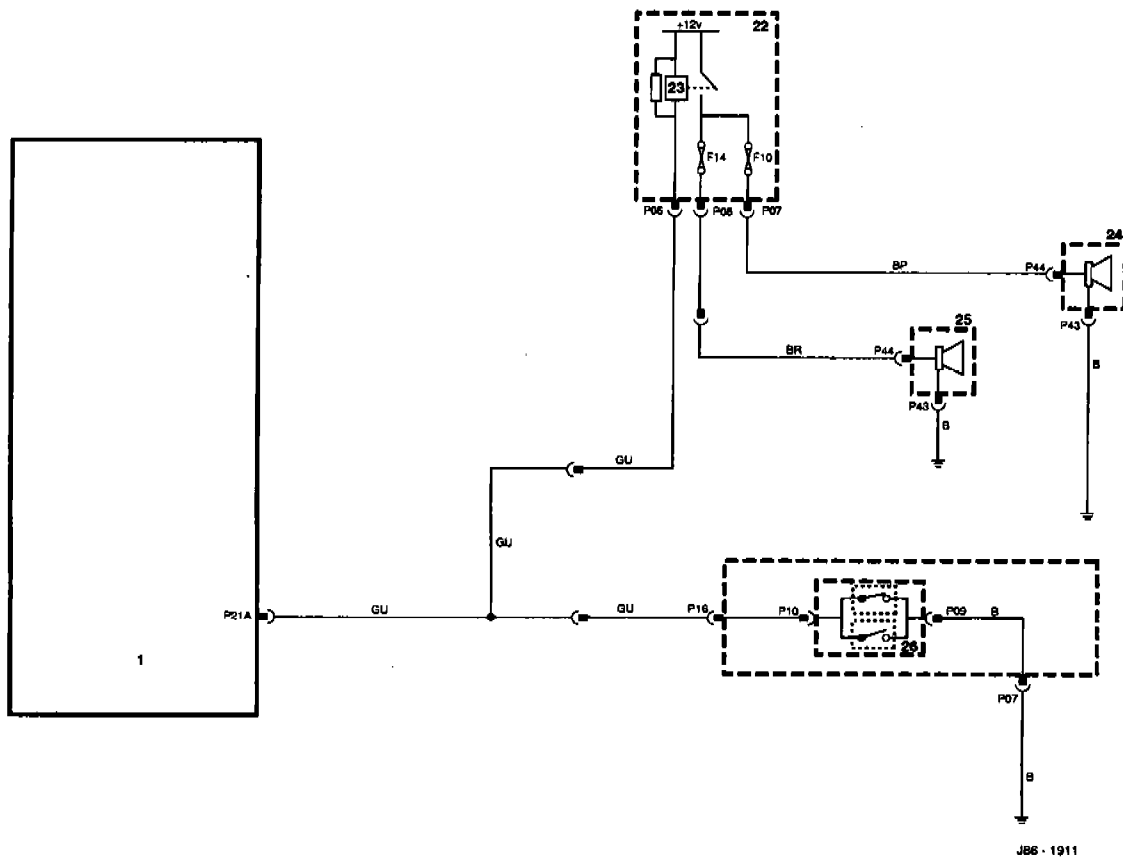
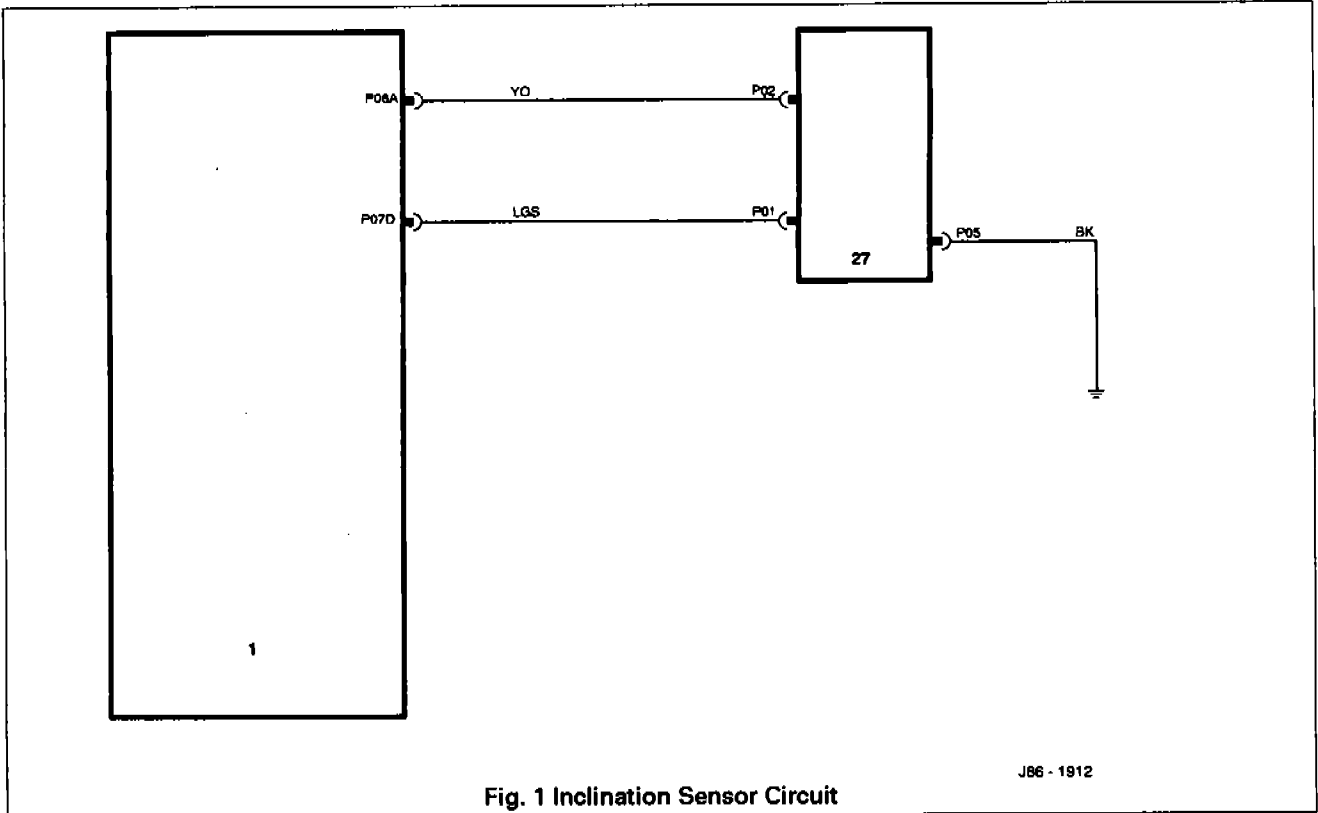

Fig. 1 Horn Unit and Relay Circuit



A5.9.7 Inclination sensor

1. Check harness wiring from multi-plug 26-way connector pin 6 to sensor connector pin 2.
2. Check harness wiring from multi-plug 22-way connector pin 7 to sensor connector pin 1.
3. Check harness wiring continuity from sensor connector pin 5 to ground.
4. Remove trim to gain access to sensor and loosen fixings. Lock and arm the vehicle (an error beep will sound indicating boot open but alarm will still set), then tilt the sensor a minimum of 15° away from horizontal checking that the alarm is activated.



A5



A5.9.8 Intrusion sensors

1. Check harness wiring continuity as shown below:

SLCM connector	Sensor connector	Function
Left-hand side sensor		
pin 10	pin 2	ground
pin 11	pin 4	40kHz
pin 12	pin 5	I / P
pin 13	pin 3	+8V
Right-hand side sensor		
pin 2	pin 2	ground
pin 3	pin 4	40kHz
pin 4	pin 1	I / P
pin 5	pin 3	+8V

2. Lock and arm the vehicle while sat inside; wait 15 seconds, then attempt to cover either sensor area with the palm of the hand. Check that sensor detects movement and activates alarm. Repeat test for second sensor.

A5

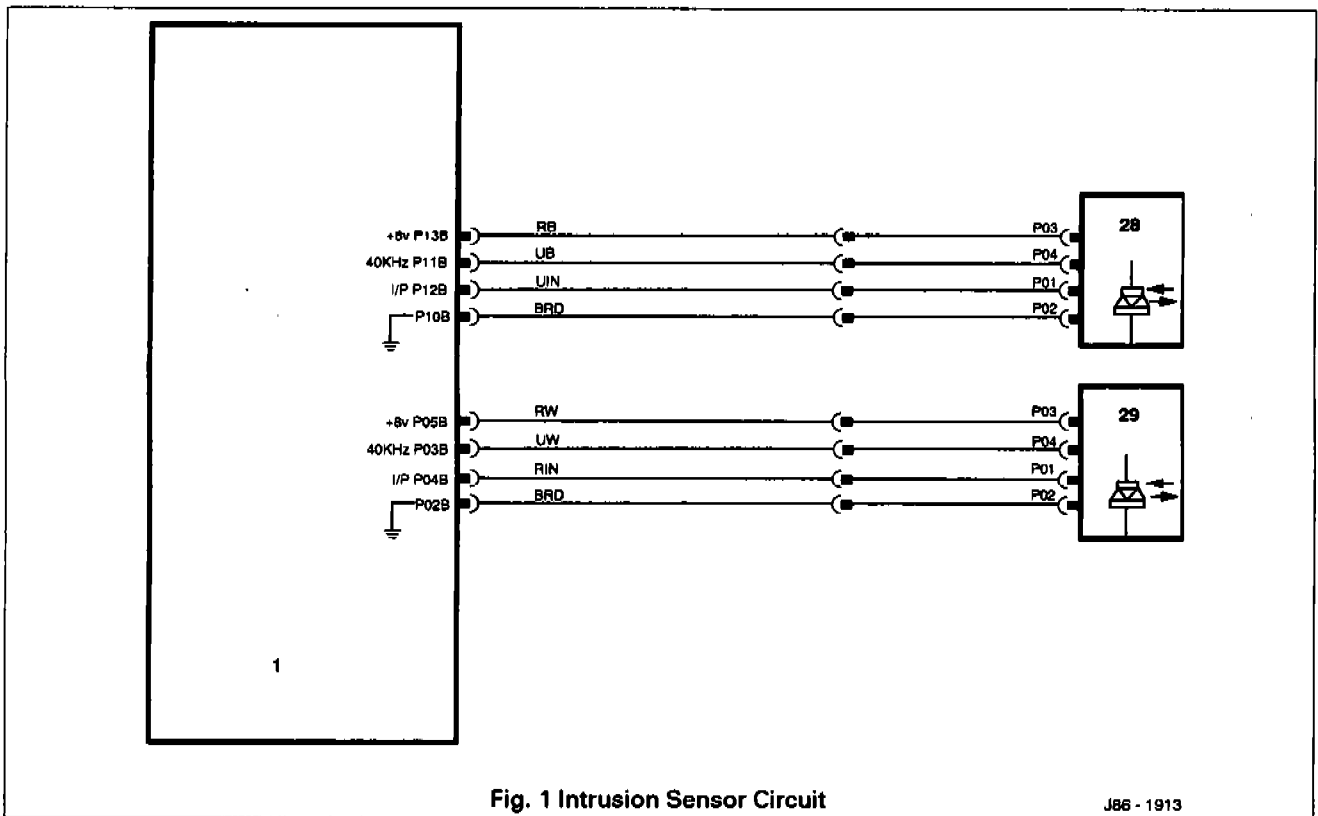

Fig. 1 Intrusion Sensor Circuit

J86 - 1913



A5.9.9 Key barrel switches

1. Check harness wiring continuity as follows:

SLCM 16-way connector	Switch	Function
Driver's side		
pin 6	pin 11	unlock signal
pin 12	pin 10	lock signal
	pin 12	ground
Passenger's side		
pin 5	pin 11	unlock signal
pin 10	pin 10	lock signal
	pin 12	ground

A5

2. Check continuity from switch pin 10 to ground with door locked, and from switch pin 11 to ground with door unlocked.

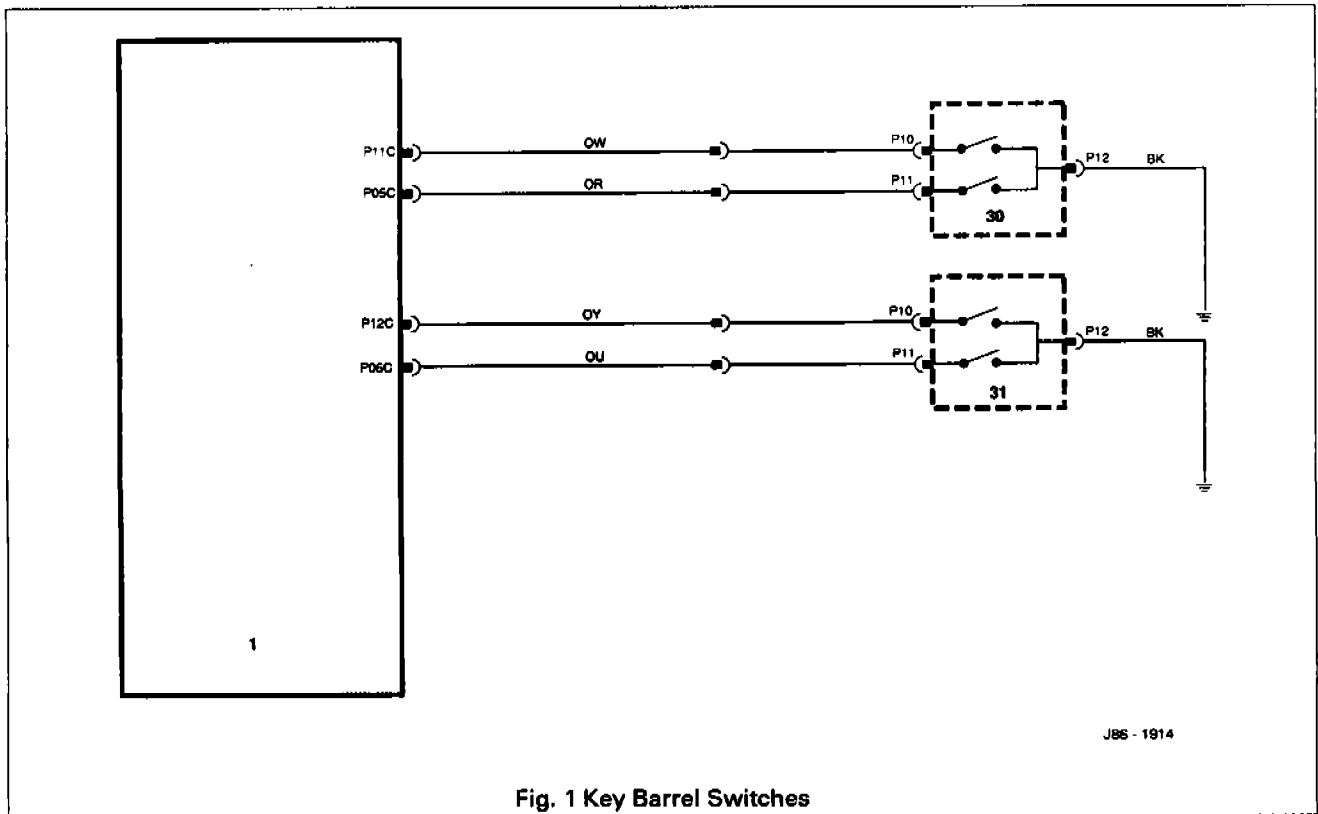

Fig. 1 Key Barrel Switches



A5.9.10 Reader exciter coil and module

1. Check fuse F4 in trunk fuse box, if blown determine reason for rupture and renew.
2. Check harness wiring continuity as follows:

SLCM connector	Module connector	Coil connector	Function
pin 6 (16-way)	pin 19	–	ground
pin 9 (12-way)	pin 06	–	data code
pin 11 (22-way)	pin 08	–	immobilization on
–	pin 1	pin 10	coil terminal 2
–	pin 9	pin 11	coil terminal 1
–	pin 10	–	+12V
–	pin 20	–	ground

3. Measure continuity between coil pins.

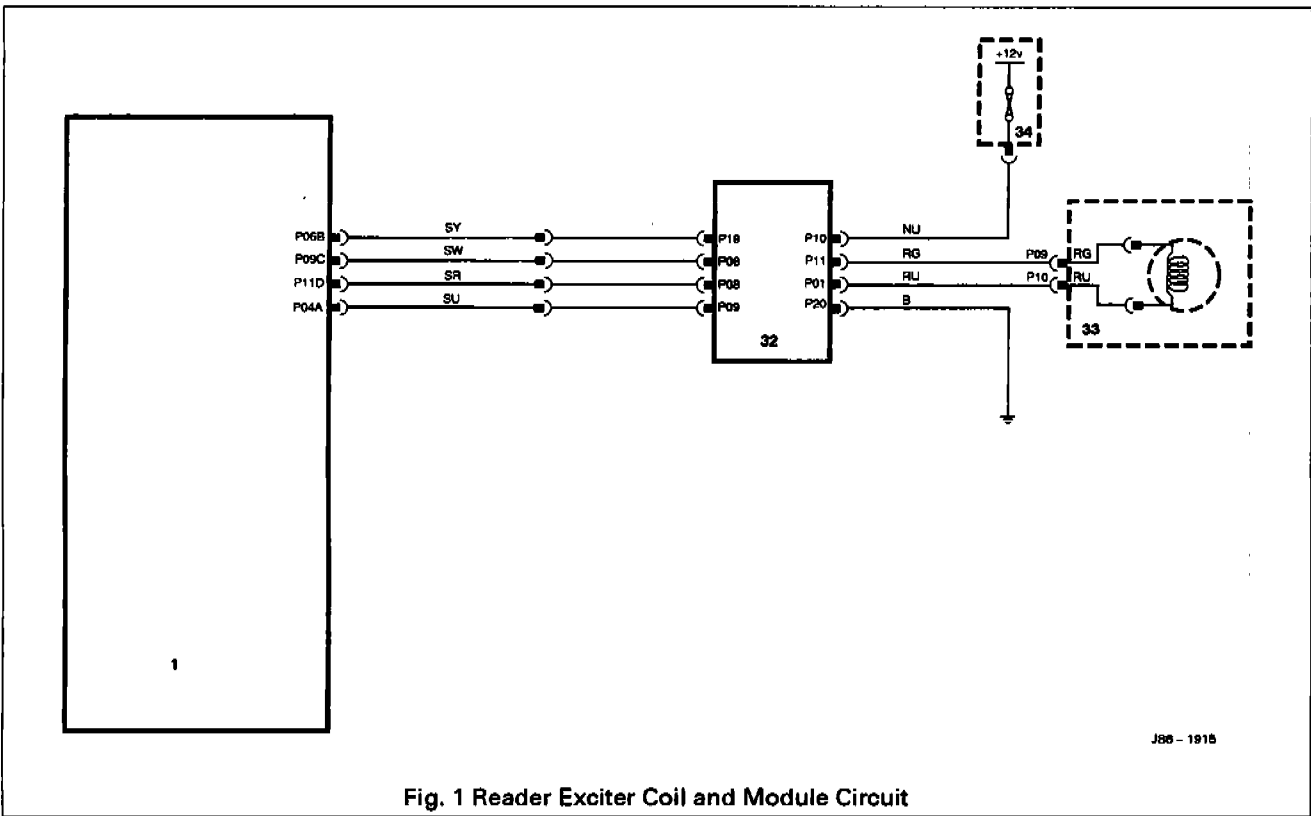

A5



A5.9.11 Security active indicator

1. Check wiring continuity from multi-plug 26-way connector pin 19 to central locking switch connector pin 13. Ensure secure ground at switch connector pin 16.

Note: If indicator is faulty the whole clock module must be renewed, refer to sub-section 15.9.10.

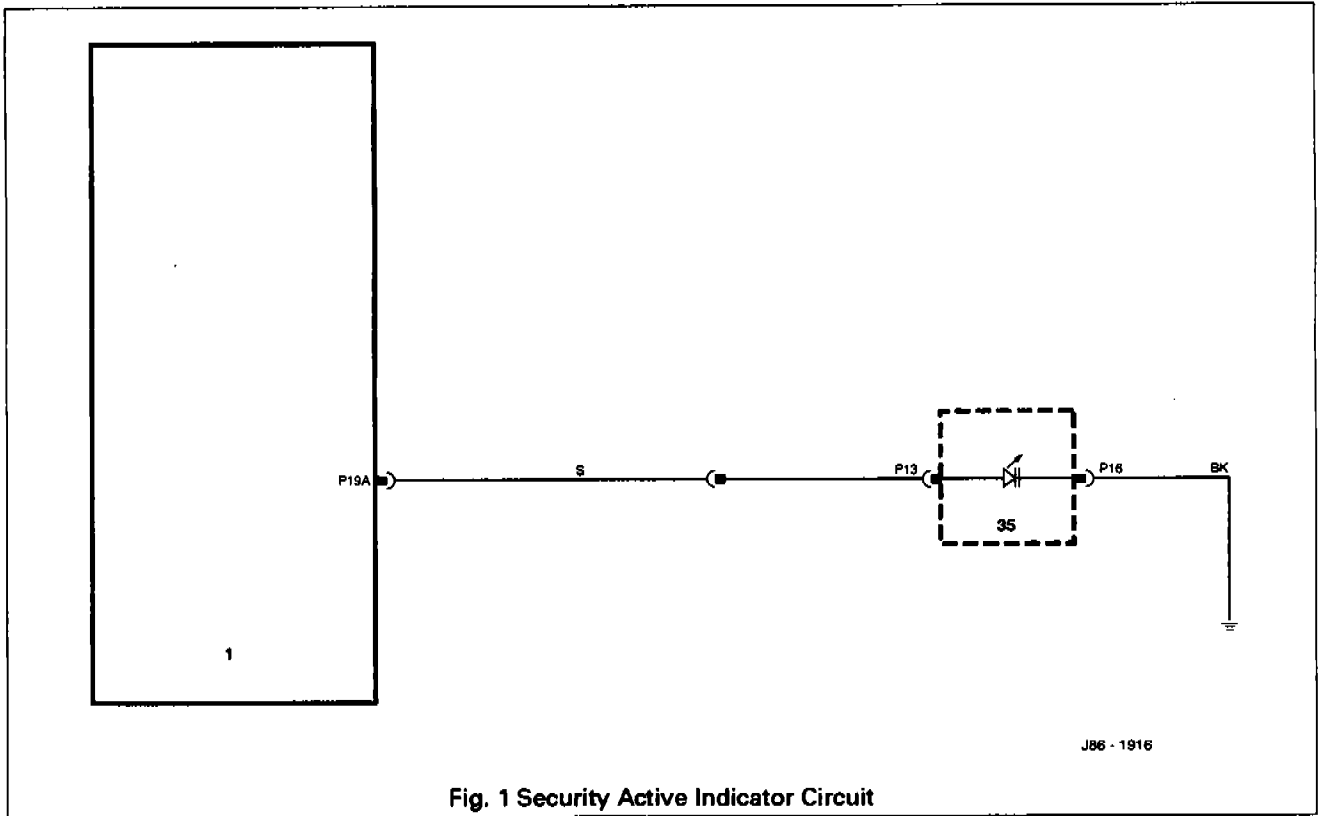

A5



A5.9.12 Sounder

1. Check harness wiring continuity from multi-plug 26-way connector pins 13 and 26 to sounder connector pins 2 and 1 respectively.
2. Measure resistance across sounder pins; a value of 8Ω should be recorded.

A5

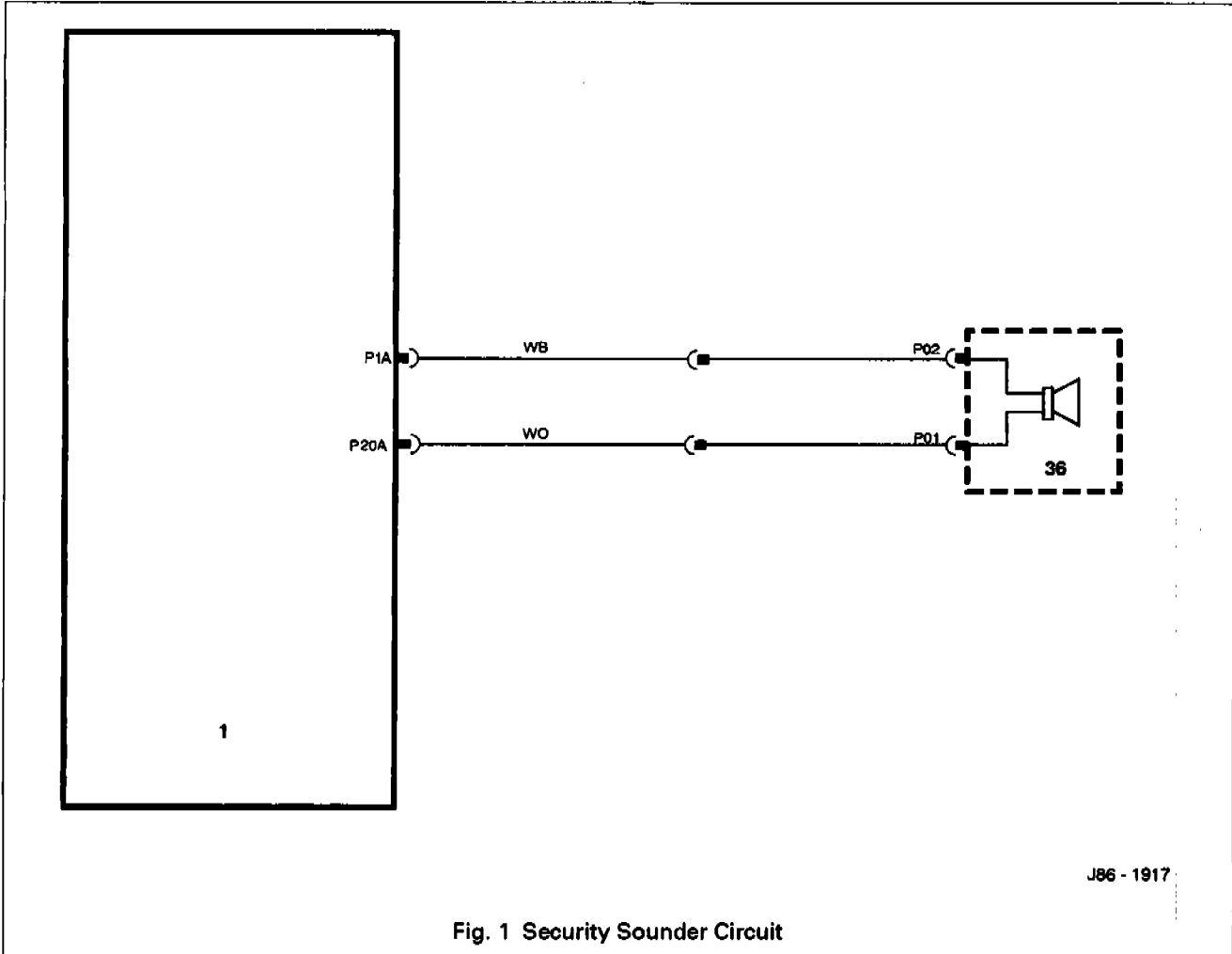



A5.9.13 Trunk lid release actuator and relay

1. Check fuse F8 in trunk fusebox; if blown determine reason for rupture and renew.
2. Check harness wiring continuity between trunk fuse box connector pin 7 and relay pins 1 and 5.
3. Check harness wiring continuity to ground from relay connector pin 4 and actuator connector pin 1.
4. Check harness wiring from multi-plug 26-way connector pin 11 to relay connector pin 2.
5. Check harness wiring continuity from relay connector pin 3 to actuator connector pin 2.
6. Measure resistance across relay connections 1 and 2; a value of 85Ω should be recorded.
7. Measure resistance across actuator pins; a value in the region of $20\text{--}30\Omega$ should be recorded.

A5

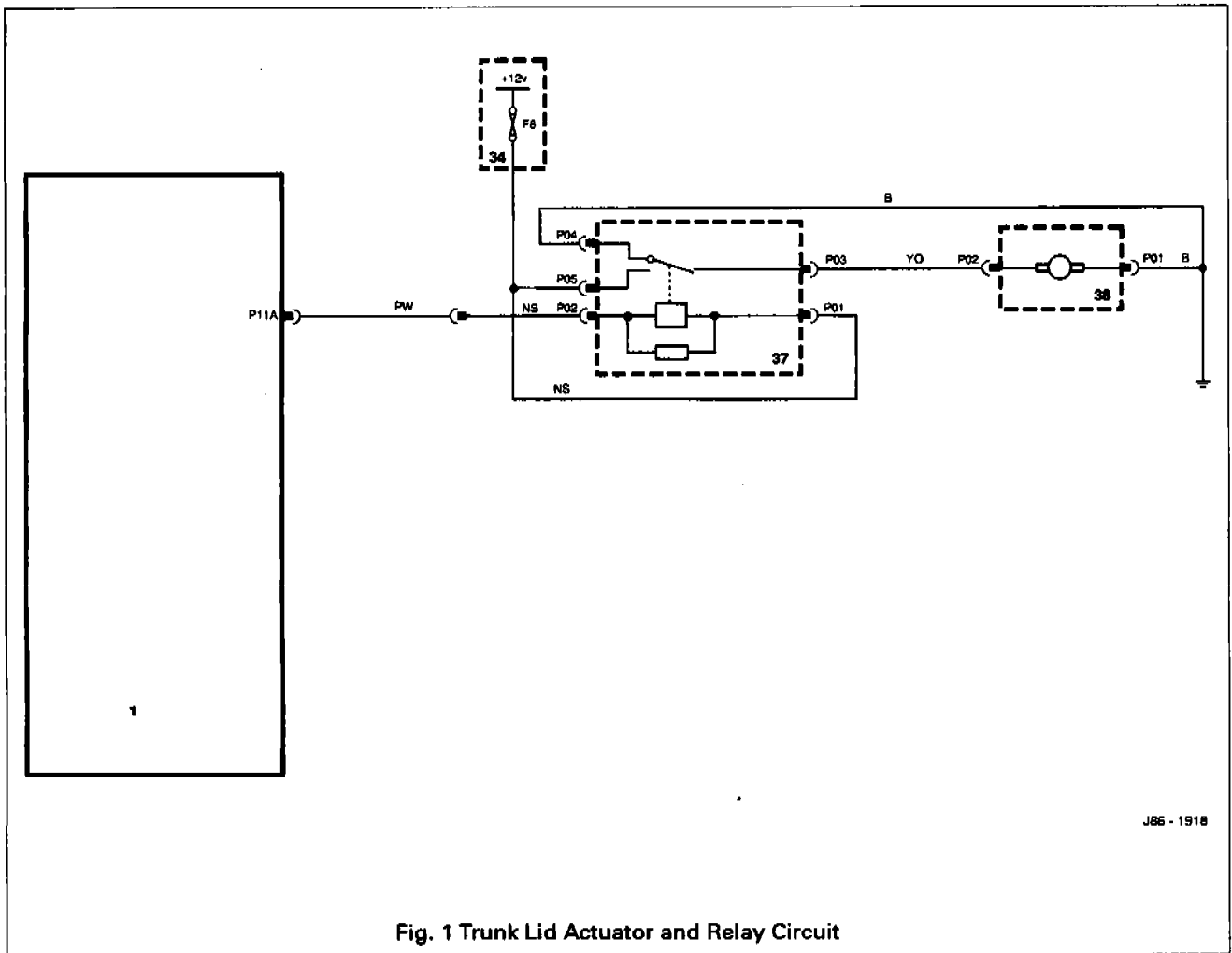

Fig. 1 Trunk Lid Actuator and Relay Circuit



A5.9.14 Trunk lid release switches

1. Check harness wiring continuity from multi-plug 12-way connector pin 2 to external trunk release switch connector pin 10. Ensure secure ground connection from switch pin 5.
2. Check harness wiring continuity from multi-plug 22-way connector pin 8 to internal trunk release switch connector pin 1. Ensure secure ground connection from switch pin 2.
3. Test continuity across switch pins, operate switch and ensure short circuit occurs.

A5

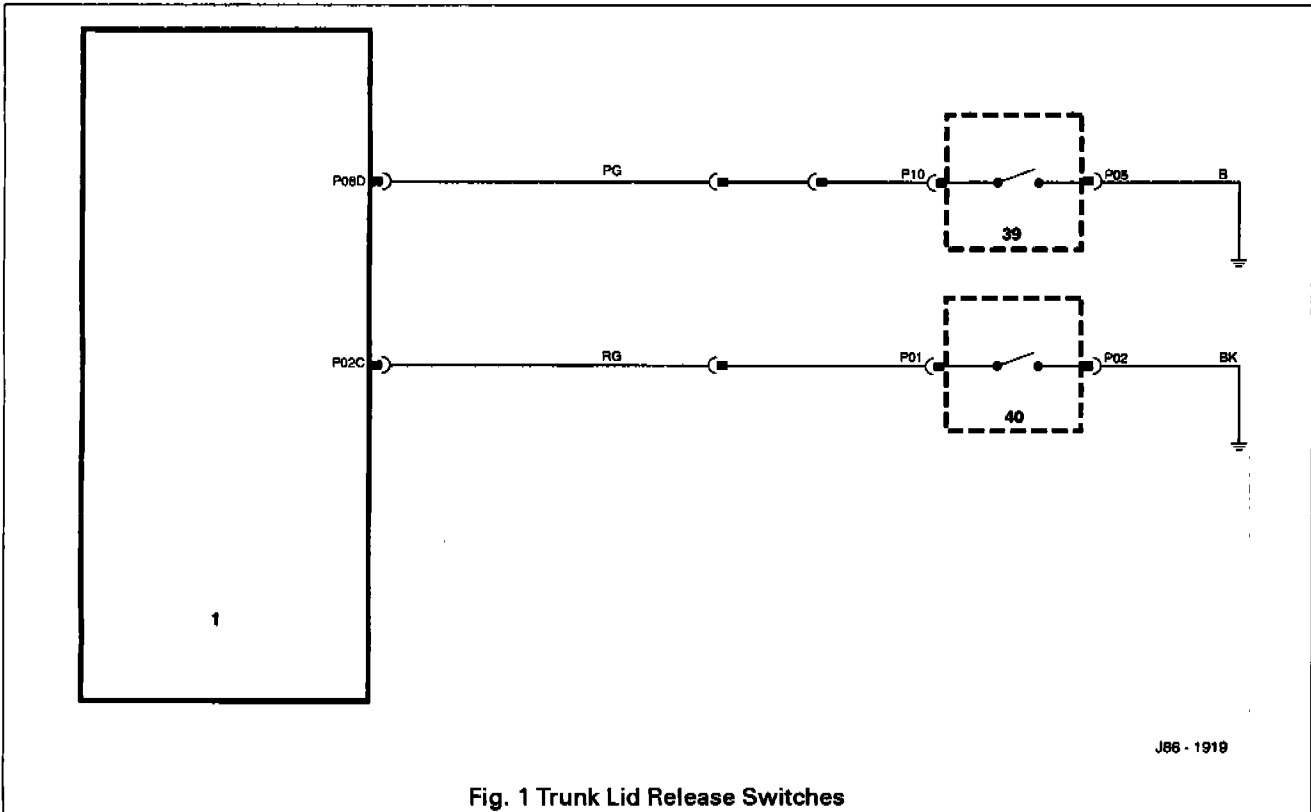

Fig. 1 Trunk Lid Release Switches



A5

A5.9.15 Valet switch

1. Check harness wiring continuity from multi-plug 22-way connector pin 6 to valet switch connector pin 1.
2. Test continuity across switch connections, operate switch and ensure short circuit occurs.

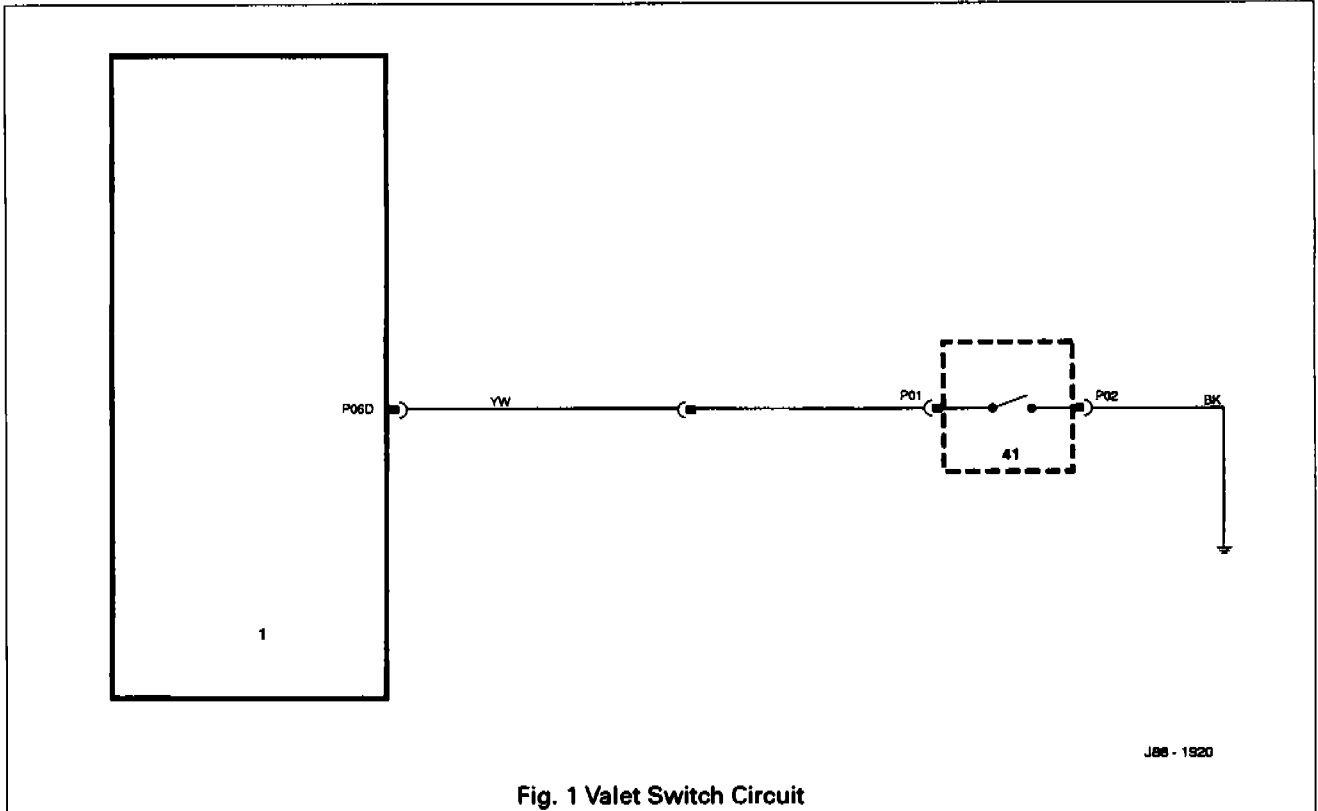



A5.10 INCLINATION SENSOR – RENEW

SRO 86.52.21

- Remove the trunk floor carpet.
- Remove the trunk front liner.
- Remove the trunk seal retainer. See SRO 76.19.44, Section 13.
- Remove the trunk side liner.
- Disconnect the inclination sensor multiplug. (1 Fig. 1).
- Undo and remove the sensor mounting bracket securing nuts (2 Fig. 1). Remove the sensor (3 Fig. 1) complete with mounting bracket (4 Fig. 1).
- Displace the mounting bracket retaining tang and remove the sensor.
- Fitting a new inclination sensor is the reverse of the removal procedure.

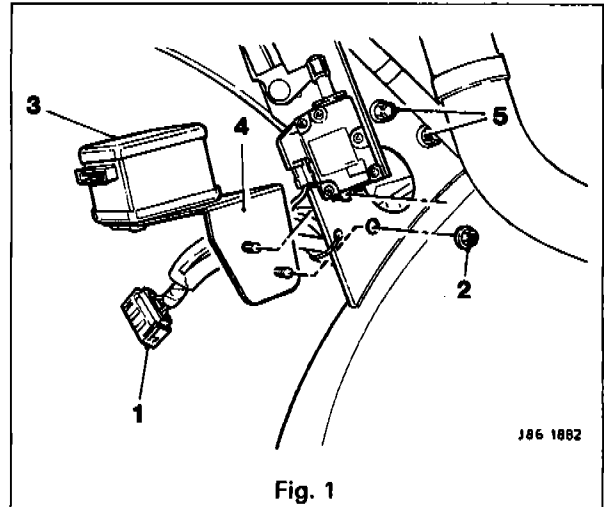

Fig. 1

A5.11 SECURITY & LOCKING CONTROL MODULE (SLCM) – RENEW

SRO 86.52.01

- Open the trunk and remove the battery cover.
- Disconnect the battery ground lead.
- Remove the trunk floor carpet.
- Remove the trunk front liner.
- Remove the trunk seal retainer. See SRO 76.19.44, Section 13.
- Remove the trunk side liner.
- Undo and remove the inclination sensor securing nuts (2 Fig. 1) and displace the sensor (3 Fig. 1) to gain access to the SLCM (1 Fig. 2).
- Undo and remove the SLCM securing nuts (5 Fig. 1).
- Displace the SLCM. Identify the SLCM multi-plugs (2 Fig. 2) for subsequent reconnection. Disconnect the multi-plugs and remove the SLCM.
- Fitting a new SLCM is the reverse of the removal procedure. Make sure that the multi-plugs are reconnected as removed from the old SLCM.

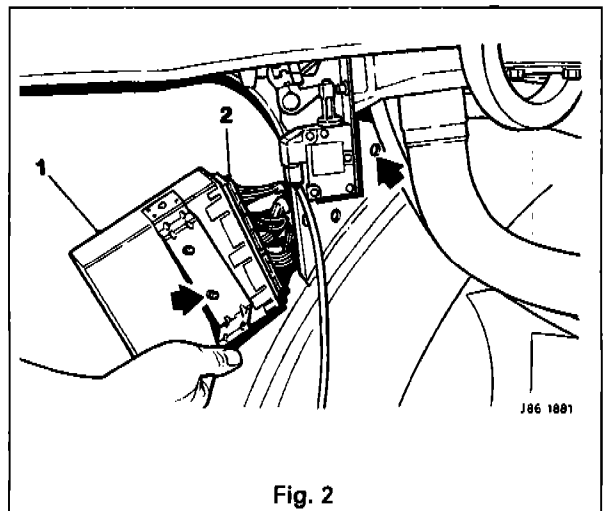

Fig. 2

Note: The arrows on Fig. 2 show the position of the mounting bolts and mounting holes.

A5



A5.12 INTRUSION SENSOR – RENEW

SRO 86.52.20

- Carefully displace the intrusion sensor from the headlining.

Note: View 1 (Fig. 1) shows a vehicle fitted with a sliding roof. View 2 (Fig. 1) shows a vehicle without a sliding roof.

- Disconnect the multi-plug and remove the intrusion sensor.
- Reconnect multi-plug to a new intrusion sensor.
- Locate the intrusion sensor securing studs and carefully push into the headlining. Make sure the intrusion sensor is fully seated.

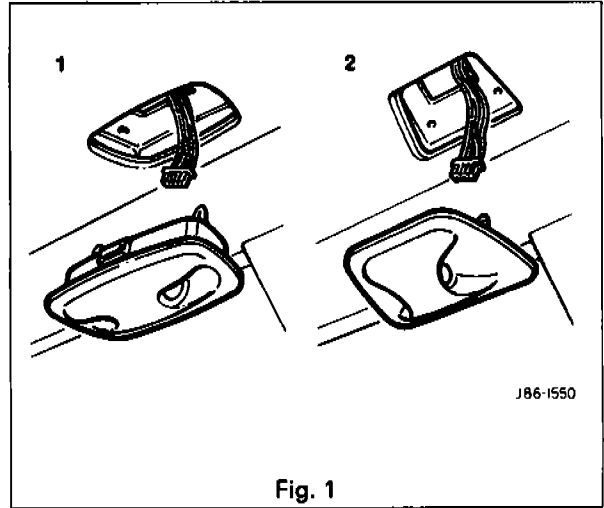

Fig. 1

A5.13 HAND TRANSMITTER BATTERY – RENEW

SRO 86.52.28

- Remove the hand transmitter rear cover (1 Fig. 2).
- Remove batteries (2 Fig. 2) and discard.
- Fit two new batteries making sure the polarity is as shown in Fig 2.
- Fit and fully seat the transmitter rear cover.

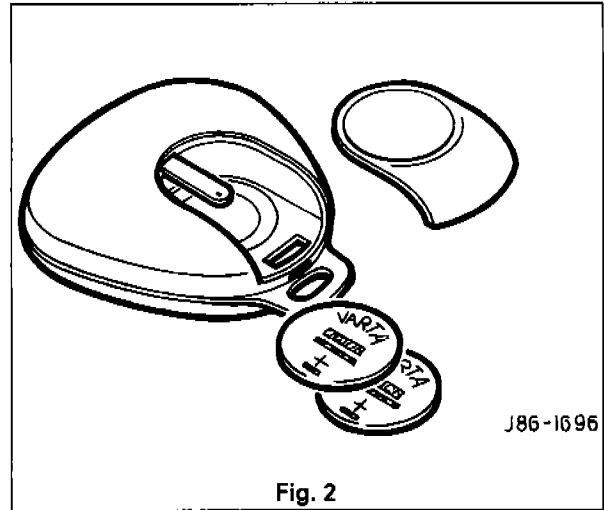

Fig. 2

A5.14 VALET SWITCH – RENEW

SRO 86.52.08

- Open the centre console compartment and carefully displace the valet switch.
- Disconnect the harness connector and remove the valet switch.
- Fitting a new valet switch is the reverse of the removal procedure. Make sure the switch is fully seated.

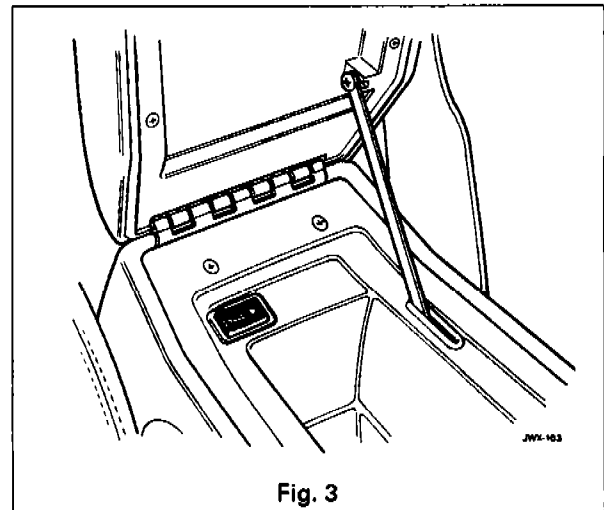

Fig. 3

A5



A5.15 SECURITY SIREN (12 CYL) – RENEW

SRO 86.52.03

- Open the trunk and remove the battery cover.
- Disconnect the battery ground lead.
- Open the hood and remove the headlamp / relay cover. See SRO 76.11.22, Section 13.
- Remove the RH air cleaner element. See SRO 19.10.11, Section 5.2.
- Remove the RH air cleaner assembly. See SRO 19.10.02, Section 5.2.
- Identify the RH forward harness relays (1 Fig. 1) for subsequent refitting. Remove the relays and relay bases from the mounting bracket.
- Disconnect the siren harness multi-plug (2 Fig. 1).
- Reposition the side harness (3 Fig. 1) to gain access to the siren securing bolts.
- Undo the siren securing bolts (1 Fig. 2) and remove the siren (2 Fig. 2).

Note: The siren securing bolts remain captive.

- Remove the captive washers and the siren securing bolts.
- Fit the siren securing bolts to a new siren.
- Fit and fully seat the captive washers.
- Align the siren securing bolts to the vehicle chassis. Tighten the siren securing bolts.

Refitting the remaining components is the reverse of the removal procedure.

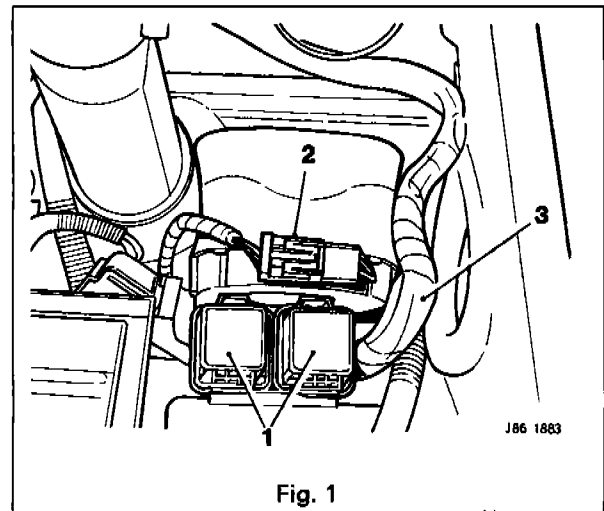

Fig. 1

A5.16 SECURITY SIREN (6 CYL) – RENEW

SRO 86.52.03

- Open the trunk and remove the battery cover.
- Disconnect the battery ground lead.
- Open the hood and remove the headlamp / relay cover. See SRO 76.11.22, Section 13.
- Identify the RH forward harness relays for subsequent refitting. Remove the relays and relay bases from the mounting bracket.
- Disconnect the siren harness multi-plug.
- Reposition the side harness to gain access to the siren securing bolts.
- Undo the siren securing bolts and remove the siren.

Note: The siren securing bolts remain captive.

- Remove the captive washers and the siren securing bolts.
- Fit the siren securing bolts to a new siren.
- Fit and fully seat the captive washers.
- Align the siren securing bolts to the vehicle chassis. Tighten the siren securing bolts.

Refitting the remaining components is the reverse of the removal procedure.

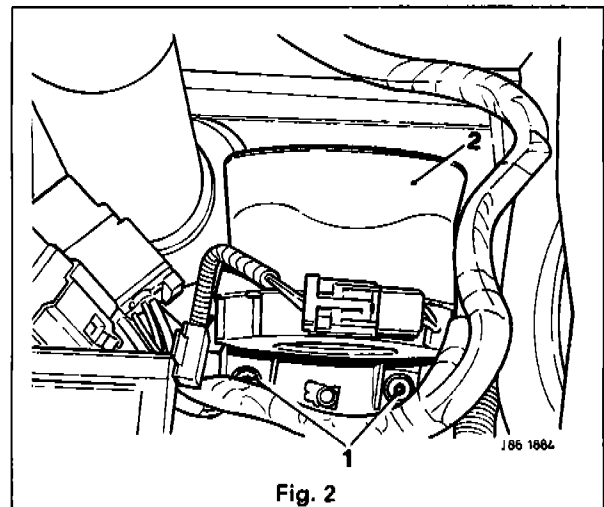

Fig. 2



A5.17 FRONT DOOR LOCK ASSEMBLY – RENEW

SRO 86.25.45

- Remove the veneer trim pad. See Section 13 of the VSM.
- Remove the upper trim pad. See Section 13 of the VSM.
- Remove the lower trim pad. See Section 13 of the VSM.
- Using a suitable plastic knife, cut through the weathershield to door sealant and pull back the weathershield (1 Fig. 1) for access to the door lock assembly.
- Disconnect the door handle link rod (2 Fig. 1).
- Disconnect the door sill button link rod (3 Fig. 1).
- Disconnect the key barrel link rod (4 Fig. 1).
- Displace and reposition the door lock assembly multi-plug from the mounting bracket and disconnect.
- Undo and remove the lower securing bolt (5 Fig. 1) from the glass frame.
- Undo and remove the door lock assembly securing bolts (6 Fig. 1).
- Displace and reposition the glass frame.
- Displace and reposition the door lock assembly (7 Fig. 1).
- Displace and remove the edge clip from the door handle release cable (8 Fig. 1).
- Displace and reposition the door handle release cable from the abutments.
- Displace and remove the door lock assembly.
- Position the new door lock assembly to the door.
- Position and fit door handle release cable to abutments.
- Fit and fully seat the cable retaining edge clip.
- Fit and tighten the door lock assembly securing bolts.
- Reposition glass frame. Fit and tighten frame securing bolt.
- Connect the multi-plug and fit to the mounting bracket.
- Connect the key barrel link rod.
- Connect the door sill button link rod.
- Connect the door handle link rod.
- Reposition the weathershield to the door. Using a suitable tool, apply pressure to the weathershield edge to ensure adhesion to the door.
- Refit the lower trim pad, upper trim pad and the veneer trim pad.

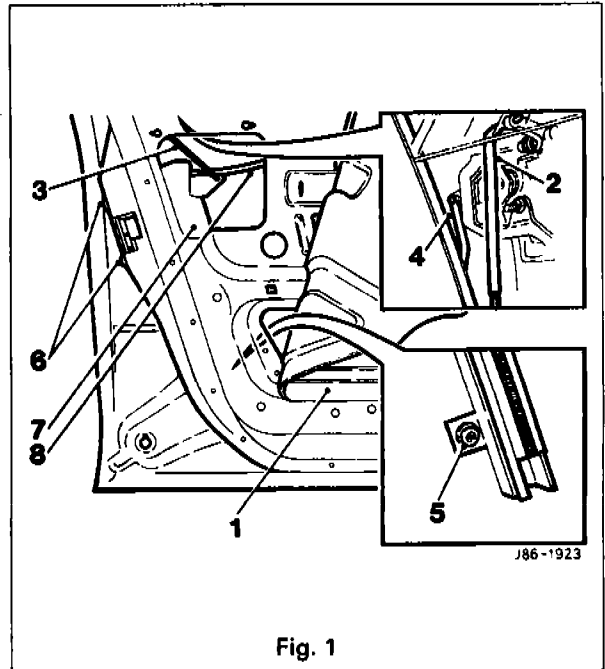

Fig. 1

A5



A5.18 REAR DOOR LOCK ASSEMBLY – RENEW

SRO 86.25.47

- Remove the veneer trim pad. See Section 13 of the VSM.
- Remove the upper trim pad. See Section 13 of the VSM.
- Remove the lower trim pad. See Section 13 of the VSM.
- Using a suitable plastic knife, cut through the weathershield to door sealant and pull back the weathershield for access to the door lock assembly.
- Cut and remove the securing tie-wrap from the door lock assembly harness multi-plug.
- Displace and reposition the door lock assembly multi-plug from the mounting bracket and disconnect.
- Disconnect the door handle link rod.
- Disconnect and remove the door sill button link rod.
- Undo and remove the door lock assembly securing bolts.
- Undo and remove the lower securing bolt from the glass frame.
- Displace and reposition the door lock assembly into the bottom of the door.
- Displace and remove the edge clip from the door handle release cable.
- Displace and reposition the door handle release cable.
- Displace and remove the door lock assembly.

A5.19 TRUNK LID LOCK ACTUATOR – RENEW

SRO 86.25.49

- Open the trunk lid.
- Remove the luggage compartment lamp assembly. See Section 15 of the VSM.
- Displace and remove the trunk lid liner fasteners and re-position for access.
- Undo and remove actuator mounting bracket securing bolts.
- Disconnect the actuator harness multi-plug.
- Disconnect the actuator to lock mechanism link rod.
- Remove the actuator and motor.
- Undo and remove the actuator to mounting bracket securing screws.

Fitting a new actuator is the reverse of the removal procedure.

15.20 CLOCK MODULE – RENEW

SRO 86.80.13

- Remove centre console ashtray and veneer panel., refer to VSM, section 13.
- Release and remove gear selector illumination module securing screws.
- Re-position illumination module as necessary for removal of radio console.
- Release radio console securing screws, partially withdraw radio console from center console so that console harness and radio aerial connectors can be removed.
- Release radio ground lead from securing nut.
- Remove dedicated radio harness connector from multi-plug.
- Fully withdraw radio console and remove radio unit.
- Release securing screws and remove clock module.

15.21 READER EXCITER COIL AND MODULE – RENEW

- Access to the reader exciter coil is gained by removing top and bottom ignition cowls, refer to VSM, Section 13 for remove / refit instructions.
- The exciter coil is mounted around the ignition switch and can be removed by releasing spring tension coil clips.
- The module is mounted on the steering column assembly, secured by two bolts.
- To remove the module disconnect the harness multi-plug and remove the securing bolts.

INDEX TO APPENDIX A5



C

Component descriptions: *Appendix A5 – 3*

Component location illustration:
Appendix A5 – 2

Control module connector: *Appendix A5 – 4*

D

Diagnostic sub-routines: *Appendix A5 – 21–23*

F

Fault diagnosis, Security system

Diagnostic sub-routines: *Appendix A5 – 21*

General: *Appendix A5 – 16*

Pin-point tests: *Appendix A5 – 24*

G

General information

Alarms: *Appendix A5 – 8*

Convenience features: *Appendix A5 – 8*

Locking: *Appendix A5 – 7*

Security system: *Appendix A5 – 8*

K

Key fob variations: *Appendix A5 – 9*

O

Operating instructions: *Appendix A5 – 12–15*

P

Pin-point tests: *Appendix A5 – 24–39*

R

Renew procedures

Clock module: *Appendix A5 – 44*

Control module: *Appendix A5 – 40*

Inclination sensor: *Appendix A5 – 40*

Intrusion sensor: *Appendix A5 – 41*

Lock assy.

Front door: *Appendix A5 – 43*

Rear door: *Appendix A5 – 44*

Reader exciter coil & module: *Appendix A5 – 44*

Security siren: *Appendix A5 – 42*

Transmitter battery: *Appendix A5 – 41*

Trunk lid lock actuator: *Appendix A5 – 44*

Valet switch: *Appendix A5 – 41*

S

SECURITY SYSTEM: *Appendix A5 – 1*

Security system

Clock module, Renew: *Appendix A5 – 44*

Diagnostic sub-routines: *Appendix A5 – 21*

Front door lock assembly, Renew: *Appendix A5 – 43*

General information

Alarms: *Appendix A5 – 8*

Convenience

All close: *Appendix A5 – 8*

Driver seat memory select: *Appendix A5 – 8*

Headlamp convenience: *Appendix A5 – 8*

Intrusion sensing override: *Appendix A5 – 8*

Remote trunk lid release: *Appendix A5 – 8*

Trunk valet isolate: *Appendix A5 – 8*

Locking

Central lock / unlock, all close:

Appendix A5 – 7

Central locking: *Appendix A5 – 7*

Deadlocking: *Appendix A5 – 7*

Drive-away locks: *Appendix A5 – 7*

Flush sill buttons / intrusion override:

Appendix A5 – 7

Interior trunk lid release: *Appendix A5 – 7*

Remote central locking: *Appendix A5 – 7*

Two-stage unlocking: *Appendix A5 – 7*

Security system

Audible tones: *Appendix A5 – 8*

Base system: *Appendix A5 – 8*

Engine immobilization: *Appendix A5 – 8*

Inclination (tilt) sensing: *Appendix A5 – 8*

Intrusion sensing: *Appendix A5 – 8*

Passive alarm: *Appendix A5 – 8*

Hand transmitter battery, Renew: *Appendix A5 – 41*

How to operate

Central locking: *Appendix A5 – 15*

Flush sill buttons: *Appendix A5 – 15*

Locking

By key: *Appendix A5 – 12*

By key ring transmitter: *Appendix A5 – 13*

Panic feature, By key ring transmitter:

Appendix A5 – 14

Passive arming: *Appendix A5 – 15*

Trunk release: *Appendix A5 – 15*

Trunk valet isolate: *Appendix A5 – 15*

Unlocking

By key: *Appendix A5 – 12*

By key ring transmitter: *Appendix A5 – 14*

Inclination sensor, Renew: *Appendix A5 – 40*

Intrusion sensor, Renew: *Appendix A5 – 41*

Key fob variations

Variant 1, Europe / UK: *Appendix A5 – 9*

Variant 2, North America: *Appendix A5 – 10*

Variant 3, Rest of world: *Appendix A5 – 11*

Pin-point tests: *Appendix A5 – 24*

Reader exciter coil & module, Renew:

Appendix A5 – 44

Rear door lock assembly, Renew: *Appendix A5 – 44*

Security & locking control module, Renew:

Appendix A5 – 40

Security siren (12 cyl), Renew: *Appendix A5 – 42*

Security siren (6 cyl), Renew: *Appendix A5 – 42*

System description: *Appendix A5 – 1*



Component descriptions

Central locking switch: *Appendix A5 – 3*
Door ajar switches: *Appendix A5 – 3*
Door lock actuator & switch: *Appendix A5 – 3*
Door lock switch: *Appendix A5 – 3*
Hood switch: *Appendix A5 – 3*
Horns: *Appendix A5 – 3*
Inclination sensor: *Appendix A5 – 4*
Intrusion sensors: *Appendix A5 – 4*
Reader exciter coil: *Appendix A5 – 4*
Reader exciter module: *Appendix A5 – 4*
Security & locking control module:
Appendix A5 – 4
Security active indicator: *Appendix A5 – 4*
Siren: *Appendix A5 – 7*
Trunk lid release (external): *Appendix A5 – 7*
Trunk lid release (internal): *Appendix A5 – 7*
Valet switch: *Appendix A5 – 7*

Component locations

Diagram: *Appendix A5 – 2*
Key: *Appendix A5 – 3*

Market variations: *Appendix A5 – 1*

Security & locking control module, Connectors:
Appendix A5 – 5, 6

System diagnostic methods, General:
Appendix A5 – 16

System Testing

Central locking: *Appendix A5 – 20*
Flush sill buttons: *Appendix A5 – 20*

Locking

By key: *Appendix A5 – 17*
By key–ring transmitter: *Appendix A5 – 18*

Panic feature, By key–ring transmitter:
Appendix A5 – 19

Passive arming: *Appendix A5 – 20*

Trunk release: *Appendix A5 – 20*

Trunk valet isolate: *Appendix A5 – 20*

Unlocking

By key: *Appendix A5 – 17*
By key–ring transmitter: *Appendix A5 – 19*

Trunk lid lock actuator, Renew: *Appendix A5 – 44*

Valet switch, Renew: *Appendix A5 – 41*

System description: *Appendix A5 – 1*

System testing: *Appendix A5 – 17–20*