



BY APPOINTMENT TO  
HER MAJESTY QUEEN ELIZABETH II  
MANUFACTURERS OF DAIMLER AND JAGUAR CARS  
JAGUAR CARS LIMITED COVENTRY



BY APPOINTMENT TO  
HER MAJESTY QUEEN ELIZABETH  
THE QUEEN MOTHER  
MANUFACTURERS OF DAIMLER AND JAGUAR CARS  
JAGUAR CARS LIMITED COVENTRY



BY APPOINTMENT TO  
HIS ROYAL HIGHNESS THE PRINCE OF WALES  
MANUFACTURERS OF DAIMLER AND JAGUAR CARS  
JAGUAR CARS LIMITED COVENTRY



# Sedan Range 1995 Electrical Guide

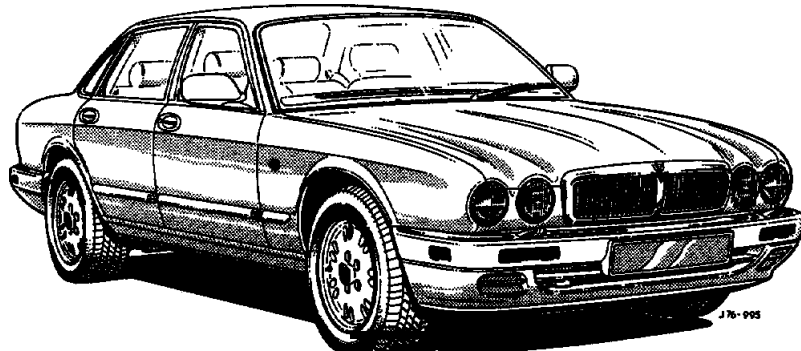



## Electrical Guide Format

This Electrical Guide is made up of two major sections. The first section, at the front of the book, provides general information for and about the use of the book. Included are a Table of Contents, a Component Index, a description of the layout of the book, definitions of symbols and abbreviations used, and illustrations which identify the type and location of common vehicle components.

The second section includes the Figures, which are the basis of the book. Each Figure is identified by a Figure Number (i.e. Fig. 01.1) and Title, and is accompanied by a page of data containing information specific to that Figure.

It is recommended that the user read through the front section of the book to develop a familiarity with the layout of the book and with the system of symbols and abbreviations used. The Table of Contents on the following pages should help to guide the user.

## Standard Abbreviations

The following abbreviations are used throughout this Electrical Guide:

DI	Direction Indicator
LH	Left-Hand
LHD	Left-Hand Drive
NA	Normally Aspirated
NAS	North American Specification
RH	Right-Hand
RHD	Right-Hand Drive
ROW	Rest of World
SC	Super Charged
SRS	Supplementary Restraint System
VIN	Vehicle Identification Number

Refer to the vehicle Service Manual for a glossary of standard terms and their abbreviations.

## Vehicle Identification Numbers (VIN)

VIN ranges are presented throughout the book in the following manner:

→ VIN 123456 indicates "up to VIN 123456"; VIN 123456 → indicates "from VIN 123456 on".

## Market Variants

**⚠** This Electrical Guide includes information for all market variants and specifications of the 1995 Sedan Range. The user must be certain to refer to the appropriate Figure (Fig.) in order to ensure that the information is specific to the particular vehicle. Market variants are detailed in the Table of Contents.



Component Index..... 6 - 12

User Instructions ..... 13 - 17

Harness Layout and Connectors..... 18 - 19

Control Module Identification and Location ..... 20 - 21

Control Module Connector Pin Identification and Location ..... 22 - 25

Relay and Fuse Box Identification and Location ..... 26

Ground Point Identification and Location ..... 27



FIGURES

Fig.	Description	Variant
<b>01 Power Distribution</b>		
01.1	Battery Power Distribution – Main .....	All Vehicles
01.2	Battery Power Distribution – Heel Board Fuse Boxes .....	All Vehicles
01.3	Battery Power Distribution – Engine Bay, Trunk Fuse Boxes .....	All Vehicles
01.4	Ignition Switched Power Distribution .....	All Vehicles
<b>02 Ground Distribution</b>		
02.1	Ignition Switched Ground Distribution .....	All Vehicles
02.2	Logic Ground Distribution .....	All Vehicles
<b>03 Battery; Starter; Generator</b>		
03.1	Battery; Starter; Generator – AJ16 4.0L NA Automatic .....	A116 4.0L NA Automatic Transmission Vehicles
03.2	Battery; Starter; Generator – AJ16 4.0L SC and 3.2L Automatic ....	AJ16 4.0L SC and 3.2L Automatic Transmission Vehicles
03.3	Battery; Starter; Generator – Manual .....	Manual Transmission Vehicles
03.4	Battery; Starter; Generator – V12 .....	V12 Vehicles
<b>04 Engine Management</b>		
04.1	AJ16 NA Federal Engine Management .....	AJ16 NA Federal Vehicles
04.2	AJ16 NA ROW Engine Management .....	AJ16 4.0L and 3.2L NA ROW Vehicles
04.3	AJ16 SC Engine Management.....	XJR Vehicles
04.4	V12 Federal Engine Management, Part 1 .....	V12 Federal Vehicles (→ 739427)
04.5	V12 Federal Engine Management, Part 2 .....	V12 Federal Vehicles (→ 739427)
04.6	V12 ROW Engine Management, Part 1 .....	V12 ROW Vehicles (→ 739427)
04.7	V12 ROW Engine Management, Part 2 .....	V12 ROW Vehicles (→ 739427)
04.8	V12 Federal Engine Management, Part 1 .....	V12 Federal Vehicles (739427 →)
04.9	V12 Federal Engine Management, Part 2 .....	V12 Federal Vehicles (739427 →)
04.10	V12 ROW Engine Management, Part 1 .....	V12 ROW Vehicles (739427 →)
04.11	V12 ROW Engine Management, Part 2 .....	V12 ROW Vehicles (739427 →)
<b>05 Transmission</b>		
05.1	AJ16 4.0L NA Automatic Transmission .....	A116 4.0L NA Automatic Transmission Vehicles
05.2	AJ16 SC Automatic Transmission .....	XJR Automatic Transmission Vehicles
05.3	AJ16 3.2L Automatic Transmission .....	AJ16 3.2L Automatic Transmission Vehicles
05.4	V12 Automatic Transmission .....	V12 Automatic Transmission Vehicles
05.5	Gearshift Interlock .....	All Automatic Transmission Vehicles
<b>06 Anti-Lock Braking; Traction Control</b>		
06.1	Anti-Lock Braking; Traction Control – LHD .....	LHD Vehicles
06.2	Anti-Lock Braking; Traction Control – RHD .....	RHD Vehicles





**FIGURES**

<b>Fig.</b>	<b>Description</b>	<b>Variant</b>
<b>07 Radiator Cooling; Air Conditioning Compressor</b>		
07.1 .....	Radiator Cooling; Air Conditioning Compressor – AJ16 .....	AJ16 Vehicles
07.2 .....	Radiator Cooling; Air Conditioning Compressor – V12 .....	V12 Vehicles
<b>08 Speed Control</b>		
08.1 .....	Speed Control .....	All Vehicles
<b>09 Exterior Lighting</b>		
09.1 .....	Headlamps; Front Fog Lamps; Front Side Lamps – ROW .....	ROW Vehicles (→ 739427)
09.2 .....	Headlamps; Front Fog Lamps; Front Side Lamps – NAS .....	NAS Vehicles (→ 739427)
09.3 .....	Tail Lamps; Rear Fog Lamps; Rear Side Lamps .....	All Vehicles (→ 739427)
09.4 .....	Stop Lamps; Reverse Lamps .....	All Vehicles (→ 739427)
09.5 .....	Direction Indicators; Hazard Warning Lamps .....	All Vehicles (→ 739427)
09.6 .....	Headlamp Leveling .....	All Vehicles
09.7 .....	Headlamps; Front Fog Lamps; Front Side Lamps .....	All Vehicles (739427 →)
09.8 .....	Tail Lamps; Rear Fog Lamps; Rear Side Lamps .....	All Vehicles (739427 →)
09.9 .....	Stop Lamps; Reverse Lamps .....	All Vehicles (739427 →)
09.10 .....	Direction Indicators; Hazard Warning Lamps .....	All Vehicles (739427 →)
<b>10 Interior Lighting</b>		
10.1 .....	Interior Lighting .....	All Vehicles
10.2 .....	Dimmer Controlled Lighting .....	All Vehicles
<b>11 Instrument Pack</b>		
11.1 .....	Instrument Normal Display .....	All Vehicles
11.2 .....	Instrument Hazard/Warning Display .....	All Vehicles
11.3 .....	Audible Warnjngs .....	All Vehicles
<b>12 Climate Control</b>		
12.1 .....	AJ16 Climate Control System, Part 1 .....	AJ16 Vehicles
12.2 .....	V12 Climate Control System, Part 1 .....	V12 Vehicles
12.3 .....	AJ16 and V12 Climate Control Systems, Part 2 .....	All Vehicles
<b>13 Steering</b>		
13.1 .....	Variable Power Steering – LHD and RHD .....	All Vehicles
13.2 .....	Column and Mirror Movement – Memory, LHD .....	LHD Memory Vehicles
13.3 .....	Column and Mirror Movement – Memory, RHD .....	RHD Memory Vehicles
13.4 .....	Mirror Movement – LHD .....	LHD Manual Column Vehicles
13.5 .....	Mirror Movement – RHD .....	RHD Manual Column Vehicles



FIGURES

Fig.	Description	Variant
<b>14</b>	<b>Seat Systems</b>	
14.1	Driver Seat – Memory, ROW .....	ROW Memory Seat Vehicles
14.2	Driver Seat – Memory, NAS .....	NAS Vehicles
14.3	Driver Seat – Non-Memory .....	Non-Memory Seat Vehicles
14.4	Driver Seat – Raise/ Lower Only .....	Raise/ Lower Seat Vehicles
14.5	Passenger Seat – Memory, ROW .....	ROW Memory Seat Vehicles
14.6	Passenger Seat – Memory, NAS .....	NAS Vehicles
14.7	Passenger Seat – Non-Memory .....	Non-Memory Seat Vehicles
14.8	Passenger Seat – Raise/ Lower Only .....	Raise/ Lower Seat Vehicles
14.9	Passenger Seat – Manual (Heater Only) .....	Manual Passenger Seat Vehicles
<b>15</b>	<b>Door Locking; Security</b>	
15.1	Central Door Locking – LHD .....	LHD ROW Vehicles
15.2	Central Door Locking – NAS .....	NAS Vehicles
15.3	Central Door Locking – RHD .....	RHD Vehicles
15.4	Security System – ROW .....	ROW Vehicles
15.5	Security System – NAS .....	NAS Vehicles
<b>16</b>	<b>Wash / Wipe System</b>	
16.1	Wash/Wipe System .....	All Vehicles
<b>17</b>	<b>Window Lifts; Sliding Roof</b>	
17.1	Window Lifts; Sliding Roof – LHD .....	LHD Vehicles
17.2	Window Lifts; Sliding Roof – RHD .....	RHD Vehicles
<b>18</b>	<b>In-Car Entertainment; Telephone</b>	
18.1	In-Car Entertainment; Telephone .....	Standard ICE Vehicles
18.2	Premium In-Car Entertainment; Telephone .....	Premium ICE ROW Vehicles
18.3	In-Car Entertainment; Telephone – NAS .....	NAS Vehicles
<b>19</b>	<b>Supplementary Restraint System</b>	
19.1	Air Bag System .....	Air Bag Vehicles
<b>20</b>	<b>Ancillaries</b>	
20.1	Ancillaries: Horns; Cigar Lighters; .....	All Vehicles
	Electrochromic Rear View Mirror; Caravan / Trailer Connector;	
	Accessory Connectors; Universal Garage Door Opener; Fold Back Mirrors	
<b>21</b>	<b>Serial Communication</b>	
21.1	Serial Communication Data Link .....	All Vehicles



ABS /TRACTION CONTROL CONTROL MODULE (LHD) .....	Fig.06.1	BRAKE FLUID LEVEL SWITCH .....	Fig. 11.2
.....	Fig.21.1	BRAKE SWITCH .....	Fig. 05.2
ABS / TRACTION CONTROL CONTROL MODULE (RHD) .....	Fig. 06.2	.....	Fig. 05.4
.....	Fig. 21.1	.....	Fig. 05.5
ACCESSORY CONNECTORS .....	Fig. 20.1	.....	Fig. 06.1
AIR BAG DIAGNOSTIC MONITOR .....	Fig. 19.1	.....	Fig. 06.2
AIR BAGS .....	Fig. 19.1	.....	Fig. 08.1
AIR CONDITIONING COMPRESSOR CLUTCH .....	Fig. 07.1	.....	Fig. 09.4
.....	Fig. 07.2	.....	Fig. 09.9
AIR CONDITIONING CONTROL MODULE .....	Fig. 07.1	.....	Fig. 14.1
.....	Fig. 07.2	.....	Fig. 14.2
.....	Fig. 10.2	.....	Fig. 14.3
.....	Fig. 12.1	CAMSHAFT POSITION SENSOR (AJ16) .....	Fig. 04.1
.....	Fig. 12.2	.....	Fig. 04.2
.....	Fig. 12.3	.....	Fig. 04.3
.....	Fig.21.1	CAMSHAFT POSITION SENSOR (V12) .....	Fig. 04.4
AIR CONDITIONING CONTROL PANEL .....	Fig. 10.2	.....	Fig. 04.6
.....	Fig.12.1	.....	Fig. 04.8
.....	Fig. 12.2	.....	Fig. 04.1C
AMBIENT TEMPERATURE SENSOR .....	Fig. 12.1	CARAVAN / TRAILER CONNECTOR .....	Fig. 20.1
.....	Fig. 12.2	CATALYST SWITCHING MODULE .....	Fig. 04.2
AMBIENT TEMPERATURE SWITCH.....	Fig. 16.1	.....	Fig. 04.6
ASPIRATOR MOTOR .....	Fig. 12.1	.....	Fig. 04.10
.....	Fig.12.2	CATALYST THERMOCOUPLES .....	Fig. 04.2
AUTO TILT SWITCH (COLUMN SWITCHGEAR).....	Fig. 13.2	.....	Fig. 04.6
.....	Fig.13.3	.....	Fig. 04.1C
BATTERY .....	Fig.01.1	CD AUTO CHANGER .....	Fig. 18.1
.....	Fig.03.1	.....	Fig. 18.2
.....	Fig. 03.2	.....	Fig. 18.3
.....	Fig. 03.3	CENTER CONSOLE SWITCH PACK .....	Fig. 09.5
.....	Fig. 03.4	.....	Fig. 09.6
BLOWER MOTORS .....	Fig. 12.3	.....	Fig. 09.10
BODY PROCESSOR MODULE .....	Fig. 01.1	.....	Fig. 11.3
.....	Fig.03.1	.....	Fig. 14.1
.....	Fig.03.2	.....	Fig. 14.2
.....	Fig.03.3	.....	Fig. 14.3
.....	Fig.03.4	.....	Fig. 14.4
.....	Fig.05.5	.....	Fig. 14.5
.....	Fig.09.1	.....	Fig. 14.6
.....	Fig. 09.2	.....	Fig.14.7
.....	Fig.09.3	.....	Fig. 14.8
.....	Fig.09.5	.....	Fig. 14.9
.....	Fig.09.7	.....	Fig.15.1
.....	Fig. 09.8	.....	Fig. 15.2
.....	Fig. 09.10	.....	Fig. 15.3
.....	Fig. 10.1	.....	Fig. 15.4
.....	Fig. 11.2	.....	Fig. 15.5
.....	Fig. 11.3	.....	Fig. 17.1
.....	Fig. 14.1	.....	Fig. 17.2
.....	Fig. 14.2	CIGAR LIGHTERS .....	Fig. 10.2
.....	Fig. 14.3	.....	Fig. 20.1
.....	Fig. 14.4	CLOCK (PART OF CENTER CONSOLE SWITCH PACK) .....	Fig.09.5
.....	Fig. 14.5	.....	Fig. 9.10
.....	Fig. 14.6	CLUTCH SWITCH (MANUAL TRANSMISSION).....	Fig.08.1
.....	Fig. 14.7	CLUTCH SWITCH LINK (AUTOMATIC TRANSMISSION1 .....	Fig.08.1
.....	Fig. 14.8	COIL (COLUMN SWITCHGEAR).....	Fig. 15.4
.....	Fig. 14.9	COLUMN/ MIRROR MOVEMENT CONTROL MODULE .....	Fig. 13.2
.....	Fig. 15.4	.....	Fig. 13.3
.....	Fig. 15.5	.....	Fig.21.1
.....	Fig. 16.1	COLUMN JOYSTICK (COLUMN SWITCHGEAR).....	Fig. 13.2
.....	Fig. 17.1	.....	Fig. 13.3
.....	Fig. 17.2		
.....	Fig.21.1		



COMPRESSOR LOCK SENSOR .....	Fig. 12.2	DOOR MIRROR MOTORS .....	Fig. 13.2
COOL AIR BYPASS SERVO .....	Fig. 12.1	.....	Fig. 13.3
.....	Fig.12.2	.....	Fig. 13.4
COOLANT LEVEL SWITCH .....	Fig. 11.2	.....	Fig. 13.5
COOLANT TEMPERATURE SENSOR .....	Fig. 11.1	DOOR SWITCH PACK – DRIVER .....	Fig. 10.1
CRANKSHAFT POSITION SENSOR .....	Fig. 04.1	.....	Fig. 10.2
.....	Fig.04.2	.....	Fig. 11.2
.....	Fig. 04.3	.....	Fig. 11.3
DATA LINK CONNECTOR .....	Fig. 21.1	.....	Fig. 13.2
DECODER MODULE .....	Fig. 03.1	.....	Fig. 13.2
.....	Fig. 05.1	.....	Fig. 13.3
DEFROST SERVO .....	Fig.12.1	.....	Fig. 13.4
.....	Fig. 12.2	.....	Fig. 13.5
DIFFERENTIAL CONTROL POTENTIOMETER .....	Fig. 12.1	.....	Fig.14.1
.....	Fig. 12.2	.....	Fig. 14.2
DIMMER (COLUMN SWITCHGEAR) .....	Fig. 10.2	.....	Fig. 14.3
DIODE (BT51) – HIGH MOUNTED STOP LAMP .....	Fig.09.4	.....	Fig. 15.4
.....	Fig. 09.9	.....	Fig. 15.5
DIODE (FC58) – WASH/ WIPE SWITCH .....	Fig. 16.1	DOOR SWITCH PACK – PASSENGER .....	Fig. 10.1
DIODE (FC59) – RH DI INDICATOR .....	Fig. 09.5	.....	Fig. 10.2
.....	Fig.09.10	.....	Fig. 11.2
DIODE (FC60) – LH DI INDICATOR .....	Fig. 09.5	.....	Fig. 14.5
.....	Fig. 09.10	.....	Fig. 14.6
DIODE (FC61) – WASH / WIPE SWITCH .....	Fig. 16.1	.....	Fig. 15.4
DIODE (PI81) – AIRP SOLENOID SUPPRESSION .....	Fig.04.1	.....	Fig. 15.5
.....	Fig.04.2	DOOR SWITCH PACK – LH REAR .....	Fig. 10.1
.....	Fig. 04.3	.....	Fig. 10.2
.....	Fig.04.5	.....	Fig. 11.2
.....	Fig.04.7	.....	Fig. 15.4
.....	Fig. 04.9	.....	Fig.15.5
.....	Fig. 04.11	DOOR SWITCH PACK – RH REAR .....	Fig. 10.1
DIRECTION INDICATOR SWITCHES (COLUMN SWITCHGEAR) .....	Fig. 09.5	.....	Fig.10.2
.....	Fig. 09.10	.....	Fig. 11.2
.....	Fig. 11.3	.....	Fig. 13.2
DIRECTION INDICATORS .....	Fig. 09.5	.....	Fig. 13.3
.....	Fig.09.10	.....	Fig.14.1
DOOR KEY BARREL SWITCHES .....	Fig. 15.1	.....	Fig. 14.2
.....	Fig. 15.2	.....	Fig. 14.3
.....	Fig. 15.3	.....	Fig. 15.4
DOOR LOCK ACTUATOR – DRIVER .....	Fig. 15.1	.....	Fig. 15.5
.....	Fig. 15.2	DOOR SWITCH – DRIVER .....	Fig. 10.1
.....	Fig. 15.3	.....	Fig. 11.2
.....	Fig.15.4	.....	Fig. 11.3
.....	Fig.15.5	.....	Fig. 13.2
DOOR LOCK ACTUATOR – PASSENGER .....	Fig.15.1	.....	Fig. 13.3
.....	Fig. 15.2	.....	Fig.14.1
.....	Fig. 15.3	.....	Fig. 14.2
.....	Fig. 15.4	.....	Fig. 14.3
.....	Fig. 15.5	.....	Fig. 15.4
DOOR LOCK ACTUATOR – LH REAR .....	Fig. 15.1	.....	Fig. 15.5
.....	Fig. 15.2	DOOR SWITCH – PASSENGER .....	Fig. 10.1
.....	Fig. 15.3	.....	Fig.11.2
.....	Fig. 15.4	.....	Fig. 14.5
.....	Fig. 15.5	.....	Fig. 14.6
DOOR LOCK ACTUATOR – RH REAR .....	Fig. 15.1	.....	Fig. 14.7
.....	Fig. 15.2	.....	Fig. 15.4
.....	Fig. 15.3	.....	Fig. 15.5
DOOR LOCK ACTUATOR – RH REAR .....	Fig. 15.1	DOOR SWITCH – LH REAR .....	Fig. 10.1
.....	Fig. 15.2	.....	Fig. 11.2
.....	Fig. 15.3	.....	Fig. 15.4
.....	Fig. 15.3	.....	Fig.15.5
DOOR LOCK ACTUATOR – RH REAR .....	Fig. 15.1	DOOR SWITCH – RH REAR .....	Fig. 10.1
.....	Fig. 15.2	.....	Fig. 11.2
.....	Fig. 15.3	.....	Fig. 15.4
.....	Fig. 15.3	.....	Fig. 15.5
DUMP VALVE .....	Fig. 08.1	E-POST LAMPS .....	Fig. 10.1



EGR TEMPERATURE SENSOR .....	Fig. 04.1	FLUID TEMPERATURE SENSOR .....	Fig. 05.1
.....	Fig. 04.3	FOG LAMPS .....	Fig. 09.1
EGR VALVE .....	Fig. 04.1	.....	Fig. 09.2
.....	Fig. 04.3	.....	Fig. 09.7
ELECTROCHROMIC REAR VIEW MIRROR .....	Fig. 20.1	FOLD-BACK MIRROR SWITCH .....	Fig. 20.1
ENGINE CONTROL MODULE (AJ16) .....	Fig. 03.1	FOLD-BACK MIRRORS .....	Fig. 20.1
.....	Fig. 03.2	FOOT WELL SERVO .....	Fig. 12.1
.....	Fig. 03.3	.....	Fig. 12.2
.....	Fig. 04.1	FRESH/ RECIRCULATION SERVOS .....	Fig. 12.1
.....	Fig. 04.2	.....	Fig. 12.2
.....	Fig. 04.3	FUEL FILLER FLAP ACTUATOR .....	Fig. 15.1
.....	Fig. 07.1	.....	Fig. 15.2
.....	Fig. 21.1	.....	Fig. 15.3
ENGINE CONTROL MODULE (V12) .....	Fig. 03.4	FUEL INJECTORS(V12) .....	Fig. 04.5
.....	Fig. 04.4	.....	Fig. 04.7
.....	Fig. 04.5	.....	Fig. 04.9
.....	Fig. 04.6	.....	Fig. 04.11
.....	Fig. 04.7	FUEL INJECTORS(AJ16 1, 2, 3) .....	Fig. 04.1
.....	Fig. 04.8	.....	Fig. 04.2
.....	Fig. 04.9	.....	Fig. 04.3
.....	Fig. 04.10	FUEL INJECTORS(AJ16 4, 5, 6) .....	Fig. 04.1
.....	Fig. 04.11	FUEL LEVEL SENSOR .....	Fig. 11.1
.....	Fig. 07.2	FUEL PUMP 1 .....	Fig. 04.1
.....	Fig. 21.1	.....	Fig. 04.2
ENGINE COOLANT TEMPERATURE SENSOR (AJ16) .....	Fig. 04.1	.....	Fig. 04.3
.....	Fig. 04.2	.....	Fig. 04.4
.....	Fig. 04.3	.....	Fig. 04.6
ENGINE COOLANT TEMPERATURE SENSOR (V12) .....	Fig. 04.4	.....	Fig. 04.8
.....	Fig. 04.6	.....	Fig. 04.10
.....	Fig. 04.8	ENGINE POSITION SENSOR .....	Fig. 04.4
.....	Fig. 04.10	.....	Fig. 04.6
ENGINE POSITION SENSOR .....	Fig. 04.4	.....	Fig. 04.8
.....	Fig. 04.6	.....	Fig. 04.10
.....	Fig. 04.8	FUEL PUMP 2 .....	Fig. 04.3
.....	Fig. 04.10	.....	Fig. 04.4
ENGINE SPEED SENSOR .....	Fig. 04.4	.....	Fig. 04.6
.....	Fig. 04.6	.....	Fig. 04.8
.....	Fig. 04.8	.....	Fig. 04.10
.....	Fig. 04.10	FUEL PUMP CONTROL MODULE .....	Fig. 04.3
EVAPORATIVE EMISSION CONTROL VALVE (AJ16) .....	Fig. 04.1	FUSE BOX - LH ENGINE BAY .....	Fig. 01.1
.....	Fig. 04.2	.....	Fig. 01.3
.....	Fig. 04.3	.....	Fig. 20.1
EVAPORATIVE EMISSION CONTROL VALVES (V12) .....	Fig. 04.5	FUSE BOX - LH HEELBOARD .....	Fig. 01.1
.....	Fig. 04.7	.....	Fig. 01.2
.....	Fig. 04.9	.....	Fig. 01.4
.....	Fig. 04.11	FUSE BOX - RH ENGINE BAY .....	Fig. 01.1
EVAPORATOR TEMPERATURE SENSOR .....	Fig. 12.1	.....	Fig. 01.3
.....	Fig. 12.2	.....	Fig. 01.4
FAN CONTROL RELAY MODULE .....	Fig. 07.1	FUSE BOX - RH HEELBOARD .....	Fig. 01.1
.....	Fig. 07.2	.....	Fig. 01.2
FASCIA SWITCH PACK .....	Fig. 06.1	.....	Fig. 01.4
.....	Fig. 06.2	FUSE BOX - TRUNK .....	Fig. 01.1
.....	Fig. 10.2	.....	Fig. 01.3
.....	Fig. 11.1	.....	Fig. 01.4
FASCIA TRUNK RELEASE SWITCH .....	Fig. 15.1	GEAR SELECTOR INDICATOR MODULE	
.....	Fig. 15.2	(AJ16 3.2L, 4.0L SC; V12) .....	Fig. 05.2
.....	Fig. 15.3	.....	Fig. 05.3
		.....	Fig. 05.4
		GEAR SELECTOR INDICATOR MODULE (AJ16 4.0L) .....	Fig. 05.1
		GEARSHIFT INTERLOCK SOLENOID .....	Fig. 05.5



GENERATOR .....	Fig.03.1	IGNITION SWITCH .....	Fig. 02.1
.....	Fig.03.2	.....	<b>Fig. 03.1</b>
.....	Fig.03.3	.....	Fig. 03.2
.....	Fig.03.4	.....	Fig. 03.3
GLOVE BOX LAMP .....	Fig. 10.1	.....	Fig.03.4
HAND BRAKE SWITCH .....	Fig. 11.1	.....	Fig. 10.1
.....	Fig. 13.2	.....	Fig. 11.3
.....	Fig. 13.3	.....	Fig. 13.2
.....	Fig. 14.1	.....	Fig. 13.3
.....	Fig. 14.2	.....	Fig. 14.1
.....	Fig. 14.3	.....	Fig. 14.2
HEADLAMP FLASH SWITCH (COLUMN SWITCHGEAR) .....	Fig.09.1	.....	Fig. 14.3
.....	Fig.09.2	.....	Fig. 14.5
.....	Fig.09.7	.....	Fig. 14.6
HEADLAMP LEVELING ACTUATORS .....	Fig. 09.6	.....	Fig. 14.7
HEADLAMPS .....	Fig.09.1	.....	Fig. 15.1
.....	Fig.09.2	.....	Fig. 15.2
.....	Fig.09.7	.....	Fig. 15.3
HEATED BACKLIGHT.....	Fig.12.3	IMPACT SENSORS .....	Fig. 19.1
HEATED OXYGEN SENSORS (AJ16) .....	Fig.04.1	IN-CAR TEMPERATURE SENSOR .....	Fig. 12.1
.....	Fig.04.2	.....	Fig. 12.2
.....	Fig.M.3	INCLINATION SENSOR .....	Fig. 15.4
HEATED OXYGEN SENSORS(V12) .....	Fig.M.4	.....	Fig.15.5
.....	Fig. 04.6	INERTIA SWITCH .....	Fig.02.1
.....	Fig.04.8	INPUT SPEED SENSOR .....	Fig.05.2
.....	Fig. 04.10	.....	Fig.05.4
HEATER MATRIX TEMPERATURE SENSOR .....	Fig. 12.1	INSTRUMENT PACK .....	Fig. 10.2
.....	Fig. 12.2	.....	Fig. 11.1
HEATER PUMP .....	Fig. 12.3	.....	Fig. 11.2
HEATER VALVE .....	Fig. 12.3	.....	Fig.21.1
HIGH MOUNTED STOP LAMP .....	Fig. 09.4	INTAKE AIR TEMPERATURE SENSOR (AJ16) .....	Fig. 04.1
.....	Fig. 09.9	.....	Fig.04.2
HOOD SWITCH .....	Fig. 15.4	.....	Fig. 04.3
.....	Fig. 15.5	INTAKE AIR TEMPERATURE SENSOR (V12) .....	Fig.04.4
HORN SWITCHES .....	Fig. 20.1	.....	Fig.04.6
HORNS .....	Fig.20.1	.....	Fig.04.8
IDLE AIR CONTROL VALVE (AJ16) .....	Fig. 04.1	.....	Fig. 04.10
.....	Fig.04.2	INTERIOR / MAP LAMPS CONSOLE .....	Fig. 10.1
.....	Fig.04.3	.....	Fig. 10.2
IDLE AIR CONTROL VALVES (V12) .....	Fig. 04.4	INTRUSION SENSORS .....	Fig. 15.4
.....	Fig. 04.6	.....	Fig. 15.5
.....	Fig. 04.8	KEYLOCK SOLENOID (COLUMN SWITCHGEAR) .....	Fig. 05.5
.....	Fig.04.10	KICKDOWN SWITCH .....	Fig.05.1
IGNITION COILS (AJ16) .....	Fig. 04.1	.....	Fig.05.2
.....	Fig.04.2	.....	Fig.05.4
.....	Fig.04.3	KNOCK SENSORS .....	Fig. 04.1
IGNITION COILS (V12) .....	Fig. 04.5	.....	Fig. 04.2
.....	Fig.M.7	.....	Fig. 04.3
.....	Fig.M.9	LAMP CONTROL MODULE .....	Fig. 09.8
.....	Fig. 04.11	.....	Fig. 09.9
IGNITION MODULES (V12) .....	Fig.04.5	.....	Fig. 09.10
.....	Fig.M.7	LIGHTING CONTROL MODULE – LH FRONT .....	Fig. 09.1
.....	Fig.M.9	.....	Fig. 09.2
.....	Fig.04.11	.....	Fig.09.5
		LIGHTING CONTROL MODULE – RH FRONT .....	Fig. 09.1
		.....	Fig. 09.2
		.....	Fig.09.5
		LIGHTING CONTROL MODULE – REAR .....	Fig.09.3
		.....	Fig.09.4
		.....	Fig. 09.5



LIGHTING SWITCHES .....	Fig. 09.1	PUDDLE LAMPS .....	Fig. 10.1
.....	Fig. 09.2	RADIATOR COOLING FANS .....	Fig. 07.1
.....	Fig. 09.3	.....	Fig. 07.2
.....	Fig. 09.7	RADIATOR THERMOSTATIC SWITCH .....	Fig. 07.1
.....	Fig. 09.8	.....	Fig. 07.2
.....	Fig. 10.2	RADIO .....	Fig. 10.2
.....	Fig. 11.3	RADIO ANTENNA .....	Fig. 18.1
.....	Fig. 16.1	.....	Fig. 18.2
LINEAR GEAR POSITION SWITCHES .....	Fig. 03.2	.....	Fig. 18.3
.....	Fig. 03.4	RADIO ANTENNA MOTOR .....	Fig. 18.1
.....	Fig. 05.2	.....	Fig. 18.2
.....	Fig. 05.3	.....	Fig. 18.3
.....	Fig. 05.4	RADIO CASSETTE .....	Fig. 18.1
.....	Fig. 09.4	.....	Fig. 18.2
.....	Fig. 09.9	.....	Fig. 18.3
.....	Fig. 13.2	READER / EXCITER CONTROL MODULE .....	Fig. 15.4
.....	Fig. 13.3	REFRIGERANT DUAL PRESSURE SWITCH .....	Fig. 07.2
MANIFOLD ABSOLUTE PRESSURE SENSORS .....	Fig. 04.4	REFRIGERANT SINGLE PRESSURE SWITCH .....	Fig. 07.1
.....	Fig. 04.6	REFRIGERANT TRIPLE PRESSURE SWITCH .....	Fig. 07.1
.....	Fig. 04.8	REPEATERS .....	Fig. 09.5
.....	Fig. 04.10	.....	Fig. 09.10
MASS AIR FLOW SENSOR .....	Fig. 04.1	REVERSE SWITCH (AJ16 MANUAL) .....	Fig. 09.4
.....	Fig. 04.2	.....	Fig. 09.9
.....	Fig. 04.3	.....	Fig. 13.2
MICROPHONE .....	Fig. 18.1	.....	Fig. 13.3
.....	Fig. 18.2	ROTARY SWITCH .....	Fig. 03.1
.....	Fig. 18.3	.....	Fig. 05.1
MID-BASS SPEAKERS .....	Fig. 18.1	.....	Fig. 09.4
.....	Fig. 18.2	.....	Fig. 09.9
.....	Fig. 18.3	.....	Fig. 13.2
MIRRORS .....	Fig. 12.3	.....	Fig. 13.3
MODE SWITCH .....	Fig. 05.1	SAFING SENSOR .....	Fig. 19.1
.....	Fig. 05.2	SEAT BELT SWITCH .....	Fig. 11.2
.....	Fig. 05.4	.....	Fig. 11.3
NOT IN-PARK MICROSWITCH .....	Fig. 05.5	SEAT CONTROL MODULE - DRIVER (NAS VEHICLES) .....	Fig. 11.2
.....	Fig. 11.3	.....	Fig. 11.3
.....	Fig. 13.2	.....	Fig. 14.2
.....	Fig. 13.3	.....	Fig. 21.1
.....	Fig. 14.1	SEAT CONTROL MODULE - DRIVER (ROW, MEMORY SEAT VEHICLES) .....	Fig. 11.2
.....	Fig. 14.2	.....	Fig. 11.3
.....	Fig. 14.3	.....	Fig. 14.1
.....	Fig. 15.1	.....	Fig. 14.3
.....	Fig. 15.2	.....	Fig. 21.1
.....	Fig. 15.3	SEAT CONTROL MODULE - PASSENGER (NAS VEHICLES) .....	Fig. 14.6
NUMBER PLATE LAMPS .....	Fig. 09.3	.....	Fig. 21.1
.....	Fig. 09.8	SEAT CONTROL MODULE - PASSENGER (ROW, MEMORY SEAT VEHICLES) .....	Fig. 14.5
OIL PRESSURE SENSOR .....	Fig. 11.1	.....	Fig. 14.7
OUTPUT SHAFT SENSOR .....	Fig. 05.1	.....	Fig. 21.1
.....	Fig. 05.2	SEAT CUSHION - DRIVER .....	Fig. 14.1
.....	Fig. 05.4	.....	Fig. 14.2
POWER AMPLIFIER .....	Fig. 18.2	.....	Fig. 14.3
.....	Fig. 18.3	.....	Fig. 14.4
POWER STEERING PRESSURE SWITCH .....	Fig. 04.5	.....	
.....	Fig. 04.7	.....	
.....	Fig. 04.9	.....	
.....	Fig. 04.11	.....	
POWER WASH PUMP .....	Fig. 16.1	.....	
PRESSURE REGULATOR .....	Fig. 05.1	.....	
PRESSURE SWITCH MANIFOLD .....	Fig. 05.2	.....	
.....	Fig. 05.4	.....	



SEAT CUSHION - PASSENGER .....	Fig. 14.5	SIDE MARKER LAMPS .....	Fig.09.2
.....	Fig. 14.6	.....	Fig.09.3
.....	Fig. 14.7	.....	Fig. 09.7
.....	Fig. 14.8	.....	Fig. 09.8
.....	Fig. 14.9		
SEAT LUMBAR PUMP - DRIVER .....	Fig. 14.1	SLIDING ROOF CONTROL MODULE .....	Fig. 17.1
.....	Fig. 14.2	.....	Fig. 17.2
.....	Fig. 14.3		
SEAT LUMBAR PUMP - PASSENGER .....	Fig.14.5	SLIDING ROOF MOTOR .....	Fig. 17.1
.....	Fig. 14.6	.....	Fig. 17.2
.....	Fig. 14.7		
SEAT MOTORS - DRIVER .....	Fig. 14.1	SLIDING ROOF SWITCH .....	Fig. 17.1
.....	Fig. 14.2	.....	Fig. 17.2
.....	Fig. 14.3		
SEAT MOTOR - DRIVER (RAISE/ LOWER SEAT VEHICLES) .	Fig. 14.4	SOLAR SENSOR .....	Fig. 12.1
		.....	Fig.12.2
SEAT MOTORS - PASSENGER .....	Fig. 14.5	SPEAKER (COLUMN SWITCHGEAR) .....	Fig. 11.3
.....	Fig. 14.6		
.....	Fig. 14.7	SPEED CONTROL BRAKE SWITCH .....	Fig.08.1
SEAT MOTOR - PASSENGER (RAISE / LOWER SEAT VEHICLES) .	Fig. 14.8	SPEED CONTROL CONTROL MODULE .....	Fig.08.1
		SPEED CONTROL SWITCHES .....	Fig.08.1
SEAT SWITCH PACK - DRIVER .....	Fig. 14.1	SQUAB - DRIVER .....	Fig.14.1
.....	Fig. 14.2	.....	Fig. 14.2
.....	Fig. 14.3	.....	Fig. 14.3
	Fig. 14.3	.....	Fig. 14.4
SEAT SWITCH PACK - DRIVE (RAISE/ LOWER SEAT VEHICLES) .....	Fig. 14.4	SQUAB - PASSENGER .....	Fig. 14.5
		.....	Fig. 14.6
SEAT SWITCH PACK - PASSENGER .....	Fig.14.5	.....	Fig. 14.7
.....	Fig. 14.6	.....	Fig. 14.8
.....	Fig. 14.7	.....	Fig. 14.9
SEAT SWITCH PACK - PASSENGER (SEATRAISE / LOWER VEHICLES) .....	Fig. 14.8	STARTER MOTOR .....	Fig. 03.1
		.....	Fig. 03.2
SECONDARY AIR INJECTION CLUTCH .....	Fig. 04.5	.....	Fig. 03.3
.....	Fig. 04.7	.....	Fig. 03.4
.....	Fig. 04.9		
.....	Fig. 04.11	STEERING COLUMN MOTORS .....	Fig. 13.2
SECONDARY AIR INJECTION PUMP .....	Fig. 04.1	.....	Fig. 13.3
.....	Fig. 04.2	SUBWOOFER .....	Fig. 18.2
.....	Fig. 04.3	.....	Fig. 18.3
SECONDARY AIR INJECTION SWITCHING VALVE .....	Fig. 04.5	SUNVISOR LAMPS .....	Fig. 10.1
.....	Fig. 04.7		
.....	Fig. 04.9	SUPERCHARGER INTERCOOLER COOLANT PUMP .....	Fig. 07.1
.....	Fig. 04.11	SUPPRESSION MODULE .....	Fig. 03.1
SECURITY AND LOCKING CONTROL MODULE .....	Fig. 03.1	.....	Fig. 03.2
.....	Fig. 03.2	.....	Fig. 03.3
.....	Fig. 03.3	.....	Fig. 03.4
.....	Fig. 03.4	TAIL LAMP UNITS .....	Fig. 09.3
.....	Fig. 15.1	.....	Fig. 09.4
.....	Fig. 15.2	.....	Fig. 09.5
.....	Fig. 15.3	.....	Fig. 09.8
.....	Fig. 15.4	.....	Fig. 09.9
.....	Fig. 15.5	.....	Fig. 09.10
.....	Fig. 21.1	TELEPHONE ANTENNA .....	Fig. 18.1
SECURITY ANTENNA .....	Fig. 15.4	.....	Fig. 18.2
.....	Fig. 15.5	.....	Fig. 18.3
SECURITY SOUNDER .....	Fig. 15.4	TELEPHONE HANDSET .....	Fig. 18.1
.....	Fig. 15.5	.....	Fig. 18.2
		.....	Fig. 18.3
SHIFT SOLENOIDS .....	Fig. 05.2	TELEPHONE TRANSCEIVER .....	Fig. 18.1
.....	Fig. 05.4	.....	Fig. 18.2
		.....	Fig. 18.3
SHORTING LINK .....	Fig. 15.1	THROTTLE POSITION SENSOR (AJ16) .....	Fig. 04.1
.....	Fig. 15.3	.....	Fig. 04.2
		.....	Fig. 04.3





THROTTLE POSITION SENSOR (V12) .....	Fig. 04.4	WINDSHIELD HEATERS .....	Fig. 12.3
.....	Fig. 04.6	WINDSHIELD WASH HEATERS .....	Fig. 16.1
.....	Fig. 04.8	WINDSHIELD WASH PUMP .....	Fig. 16.1
.....	Fig. 04.10	WIPER MOTOR .....	Fig. 16.1
TORQUE CONVERTER CLUTCH SOLENOID .....	Fig. 05.2		
.....	Fig. 05.4		
TRACTION CONTROL ACTUATOR (LHD) .....	Fig. 06.1		
TRACTION CONTROL ACTUATOR (RHD) .....	Fig. 06.2		
TRANSMISSION CONTROL MODULE (AJ16 NA) .....	Fig. 05.1		
.....	Fig. 21.1		
TRANSMISSION CONTROL MODULE (V12 & AJ16 SC) .....	Fig. 05.2		
.....	Fig. 05.4		
.....	Fig. 21.1		
TRANSMISSION SOLENOID VALVES .....	Fig. 05.1		
TRANSMISSION TEMPERATURE SENSOR .....	Fig. 05.2		
.....	Fig. 05.4		
TRIP CYCLE (COLUMN SWITCHGEAR) .....	Fig. 11.1		
TRUNK LAMPS .....	Fig. 10.1		
TRUNK RELEASE ACTUATOR .....	Fig. 15.		
.....	Fig. 15.		
.....	Fig. 15.3		
TRUNK RELEASE SWITCH .....	Fig. 15.		
.....	Fig. 15.		
.....	Fig. 15.3		
TRUNK SWITCH .....	Fig. 10.1		
.....	Fig. 11.2		
.....	Fig. 15.4		
.....	Fig. 15.5		
TWEETERS .....	Fig. 18.1		
.....	Fig. 18.2		
.....	Fig. 18.3		
VACUUM PUMP AND CONTROL VALVE .....	Fig. 08.1		
VALET SWITCH .....	Fig. 15.1		
.....	Fig. 15.2		
.....	Fig. 15.3		
.....	Fig. 15.4		
.....	Fig. 15.5		
VARIABLE FORCE MOTOR .....	Fig. 05.2		
.....	Fig. 05.4		
VARIABLE POWER STEERING CONTROL MODULE .....	Fig. 13.1		
VARIABLE STEERING CONVERTER .....	Fig. 13.1		
VENT SERVO .....	Fig. 12.1		
.....	Fig. 12.2		
WASH / WIPE SWITCHES (COLUMN SWITCHGEAR) .....	Fig. 16.1		
WASHER FLUID LEVEL SWITCH .....	Fig. 11.2		
.....	Fig. 16.1		
WHEEL SPEED SENSORS .....	Fig. 06.1		
.....	Fig. 06.2		
WINDOW LIFT MOTORS .....	Fig. 17.1		
.....	Fig. 17.2		
WINDOW LIFT SWITCH PACKS .....	Fig. 17.1		
.....	Fig. 17.2		



## Figure and Data Page Layout

### Figure Pages

Each Figure represents a specific electrical system of the vehicle. The Figures are arranged numerically by system (**01 – Power Distribution, 02 – Ground Distribution, etc.**) with variations in the system identified by a numeral following a decimal point (**01.1, 01.2, etc.**). Refer to the Table of Contents for a complete list of the Figures.

The Figures **01 – Power Distribution** detail the distribution of power to each of the systems. Numbered reference symbols refer the user to a specific Figure and from a specific Figure back to the Power Distribution Figures. This eliminates the need to include detailed Power Distribution information on each of the Figures. Similarly, the Figures **02 – Ground Distribution** detail the vehicle ground distribution. The reference symbols are defined on page 15.

Each Figure appears on a right-hand page with a corresponding Data page to the left. The Figure and Data pages are folding pages. The user must fold out both pages in order to access all the information provided.

### Data Pages

The Data page includes information to assist the user in identifying and locating components, connectors and grounds. This information is supplemented by the illustrations in this front section of the **book**.

In addition, where circuits include a Control Module, Pin Out information is provided with values for "active" and "inactive" states. The values listed are approximately those that can be expected at the control module connector pins with all circuit connections made and all components connected and fitted. "Active" means a load is applied or a switch is ON; "inactive" means a load is not applied or a switch is OFF. This information is provided to assist the user in understanding circuit operation and should be used **FOR REFERENCE ONLY**.

Samples of the Figure and Data pages are shown on the following page.

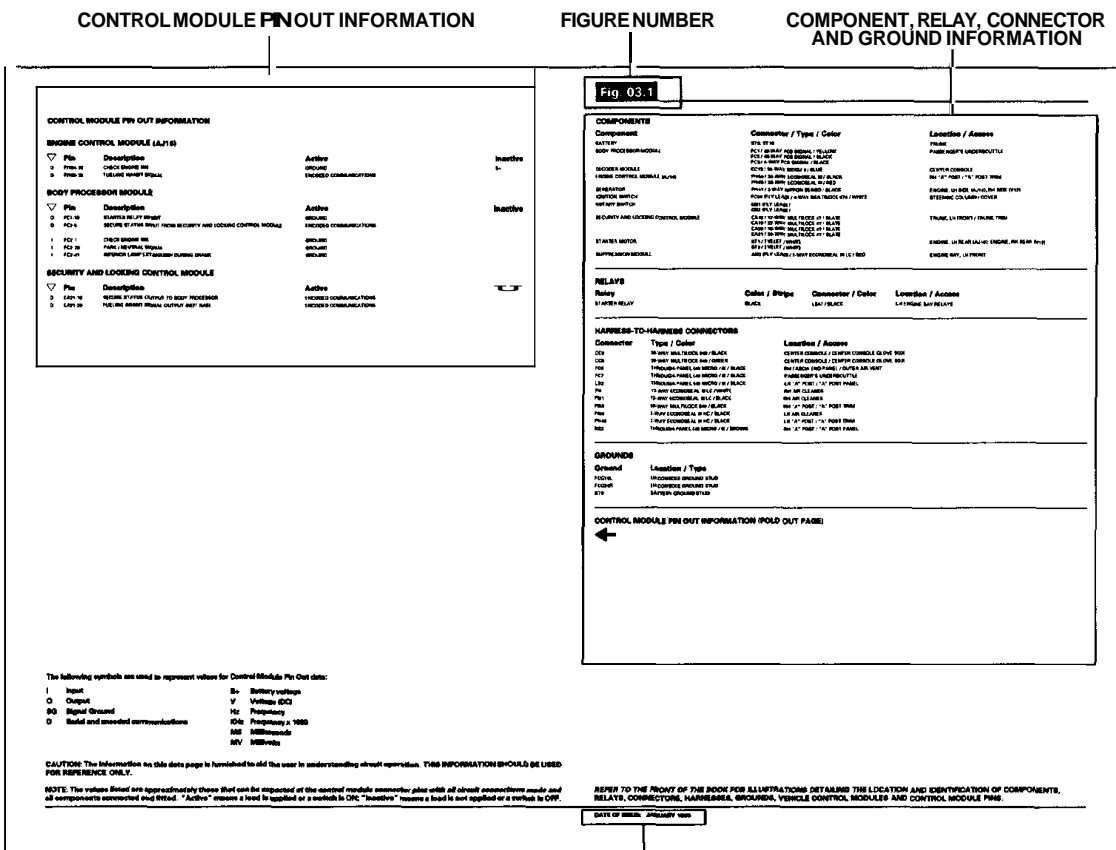

DATE OF ISSUE  
DATA PAGE

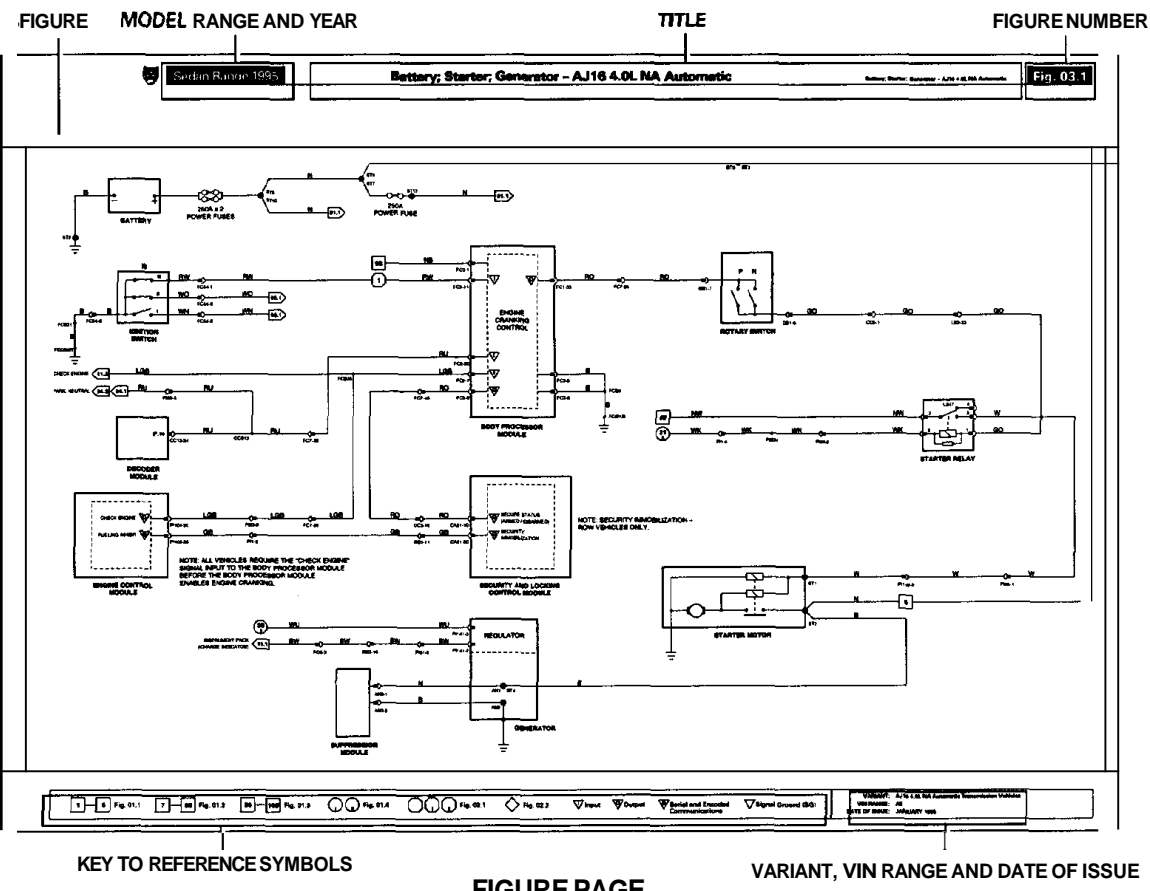



### Wiring Symbols

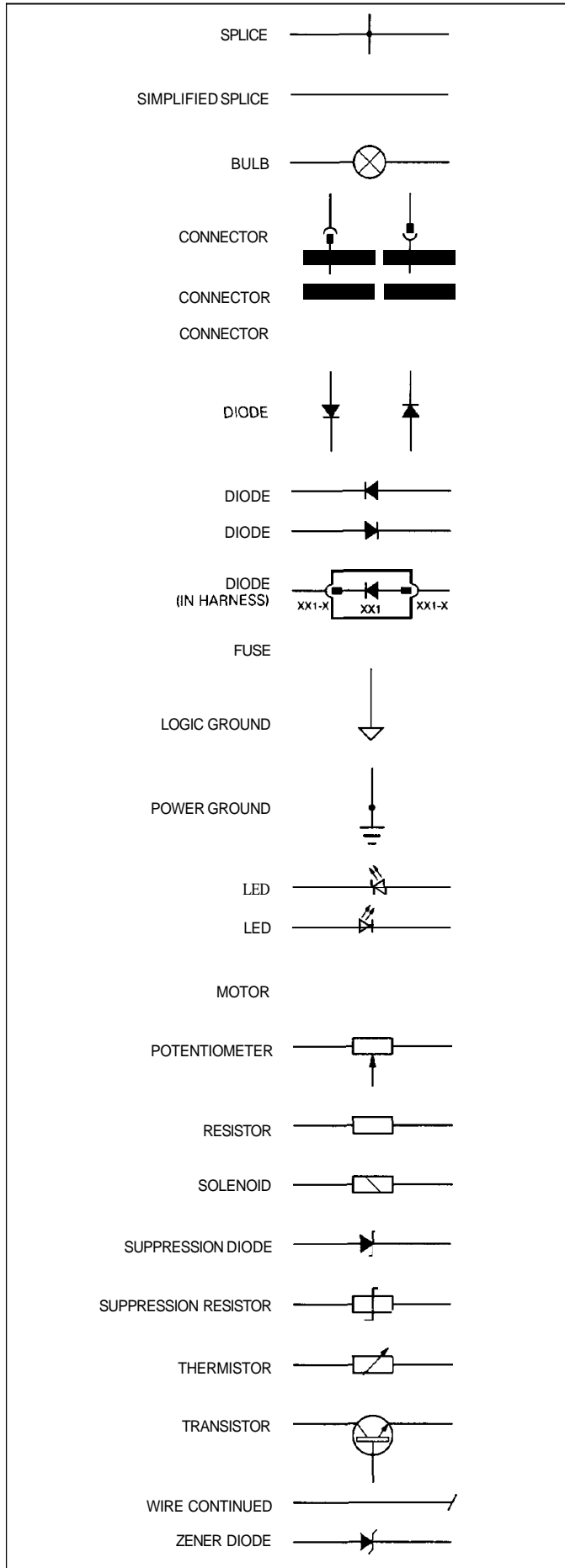

### Wiring Color Codes

N	Brown	O	Orange
B	Black	S	Slate
W	White	L	Light
K	Pink	U	Blue
G	Green	P	Purple
R	Red	BRD	Braid
Y	Yellow		

When a wire has two or more color code letters, the first letter indicates the main color and the subsequent letter(s) indicate the tracer color(s).

### Wiring Harness Codes

Code	Description
AB	Air bag
AN	Generator suppression
BL	Front bumper - left
BR	Front bumper - right
BT	Boot (trunk)
CA	Cabin
CC	Center console
CF	Cooling fan link
CL	Air bag impact sensor link - left
CR	Air bag impact sensor link - right
CS	Clutch shorting link
DD	Driver door
DL	Non dead locking shorting link
FC	Facia
FU	Fuel pump
GB	Automatic transmission
IC	In-car entertainment
LL	Variable steering converter
LS	Left forward
ML	Manual seat link
OL	Octane select link
PD	Passenger door - front
PI	Engine management
PL	Powered seat link
RD	Rear door (suffix L - left, suffix R - right)
RF	Roof security
RS	Right forward
RT	Radio telephone
SA	Starter solenoid
SH	Front screen (windshield) heater
SL	Starter solenoid link
SM	Memory seat
SR	Side marker link (rear)
TL	Tail lamps
TS	Traction shorting link



**NOTE** In the examples shown on these pages, an 'X' is used where a number would appear on an actual Figure.

**Harness Component Numbers**

**Connectors**

HARNESS CODE + CONNECTOR NUMBER + PIN NUMBER

EXAMPLE: FC7-24 (pin number is separated by a dash)

NOTE: Door harnesses use common connector numbers with D, P, L or R added to indicate the door – Driver, Passenger, Left rear, Right rear.

**Splices**

HARNESS CODE + S + IDENTIFICATIONNUMBER

EXAMPLE: CAS3 (no dash is used)

NOTE: In order to avoid unnecessary circuit complication, multiple splices (more than two wires) within components, in wires leading from input components to multiple circuits and in harness 'ground' sides are simplified so as not to show wires from other circuits.

EXAMPLE: \_\_\_\_\_

**Grounds**

HARNESS CODE + G + IDENTIFICATIONNUMBER

EXAMPLE: BTG14 (no dash is used)

NOTE: Ground identifications that include 'L' or 'R' after the number indicate that the eyelet has two 'legs'. The 'L' or 'R' identifies the particular leg of the eyelet to which the wire is connected.

**Diodes**

Harness diodes occur at connectors and are depicted as components and identified by a connector number.

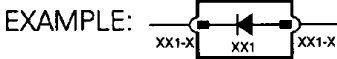

**Relay Connectors**

Relay connector numbers are shown within the relay. The harness code is shown in the upper portion of the relay; the pin (terminal) number is shown adjacent to the pin.

NOTE: Certain relays are paired and share a modular connector. In this instance, the relay terminal code is included in parentheses.

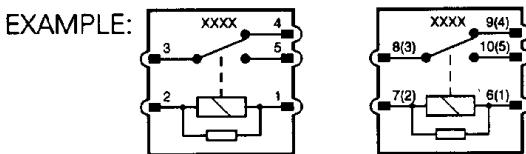



### Reference Symbols

Reference symbols are used for three purposes:

- to allow the user to complete the individual system circuit to power supply or ground
- to refer the user to a related circuit
- to identify control module inputs, outputs and signal grounds

#### **Battery Power Supply**

This symbol represents a direct battery power supply and refers the user to Figure 01 - 101.2 or 01.3

#### **Ignition Switched Power Supply**

This symbol represents ignition switched power supply and refers the user to Figure 01.4.

The suffix I indicates auxiliary power. Power is supplied in ignition switch key positions I (AUXILIARY) and II (IGNITION).

The suffix II indicates ignition power. Power is supplied in ignition switch key positions II (IGNITION) and III (ENGINE CRANK).

#### **Ignition Switched Ground**

This symbol represents an ignition switched ground and refers the user to Figure 02.1.

No suffix indicates CRANK. Ground is completed in ignition switch key position III (ENGINE CRANK).

The suffix I indicates auxiliary ground. Ground is completed in ignition switch key positions I (AUXILIARY) and II (IGNITION).

The suffix II indicates ignition ground. Ground is completed in ignition switch key positions II (IGNITION) and III (ENGINE CRANK).

#### **Logic Ground**

This symbol represents a logic ground and refers the user to Figure 02.2.

#### **Figure Number Reference Flag**

This symbol refers the reader to a figure number only. It does not refer to a flag with the same number on a different figure.

As used in Figures 01.1 through 02.2, the reference flag refers the user to a continuation of the circuit. In this instance, the user matches the number to a Power Supply or Ground symbol to trace the circuit.

In most other cases, it is not necessary to refer to another figure for completion of a circuit, as the reference flags are used to indicate parallel circuits and circuits that share components. Most of the circuits where this situation occurs are overlapped to avoid the necessity for cross-referencing to another figure. Exceptions to this rule are instances where signals are transmitted to or received from other system circuits.

**BPM** Because the Body Processor Module appears numerous times, the abbreviation BPM is used in the reference flag on Figure 01.3 in order to conserve space.

### Control Module Input, Output, Data Line and Signal Ground



These four symbols are employed to assist the user in visualizing the 'logic' of circuits containing control modules. These symbols identify control module input, output, data line and signal ground pins. These symbols are also employed on the corresponding data page.



The following connectors are the common harness-to-harness connectors used throughout the vehicle.

### Multilock 040

Low current (used as harness and 'direct' connection connector).

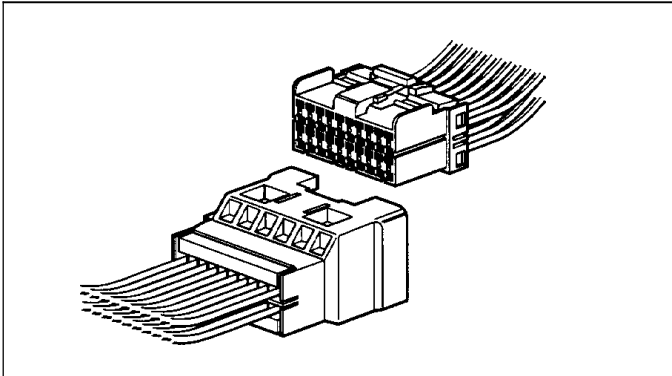

### Multilock 070

High current (used as harness and 'direct' connection connector).

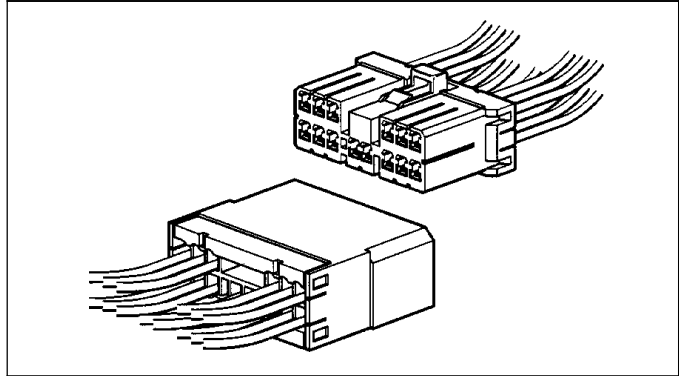

### Econoseal III LC

Low current sealed connector.

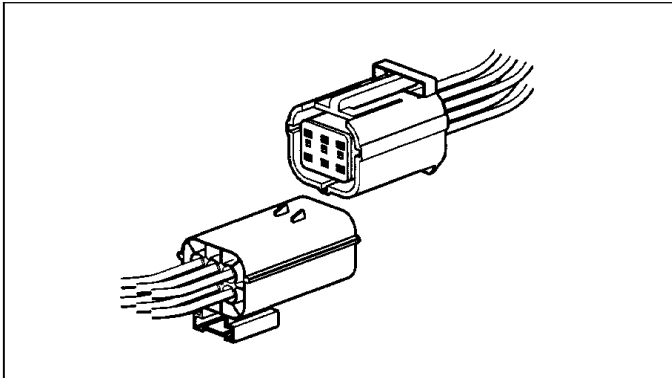

### Econoseal III HC

High current sealed connector.

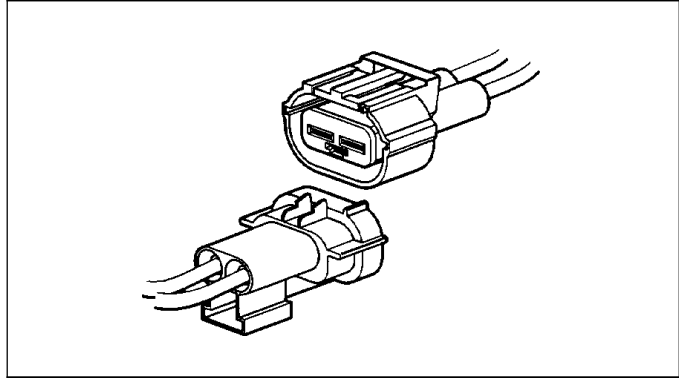

### Through-Panel

48 low-current pins / 6 high-current pins.

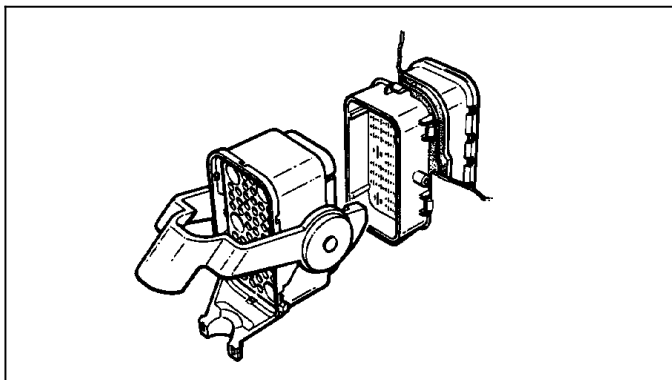

### Ford Card

Used for SRS only.

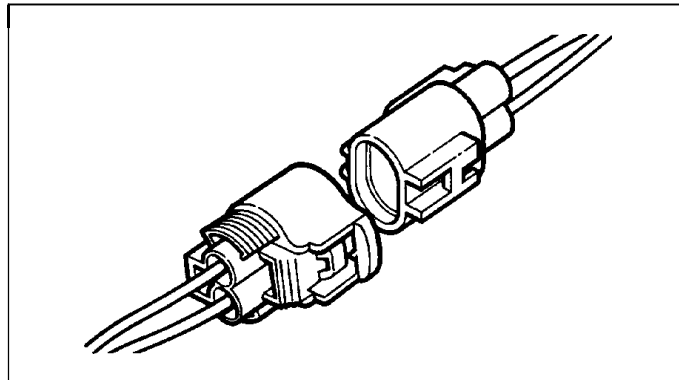



HARNESSLAYOUT

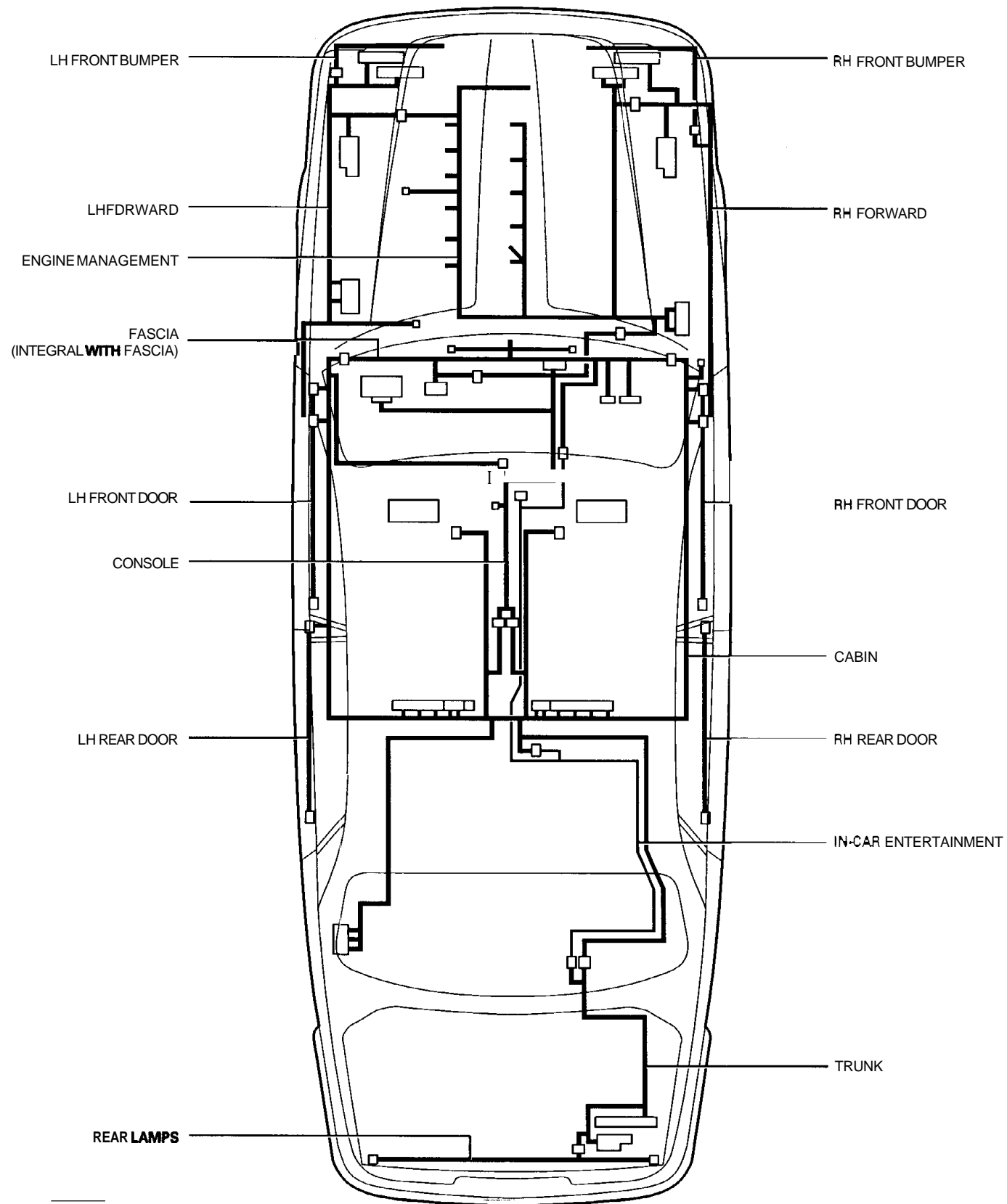

HARNESCONNECTORS

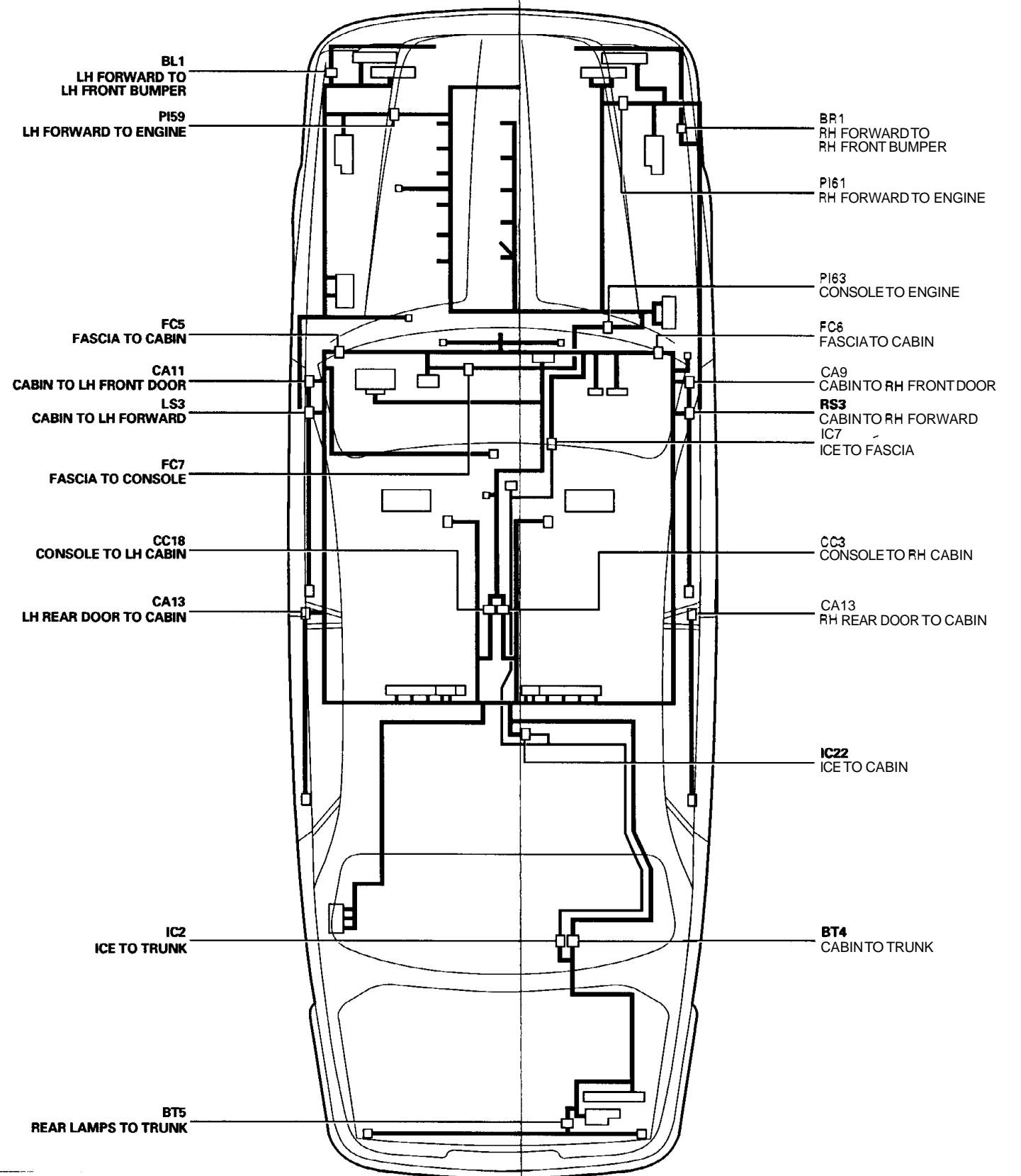



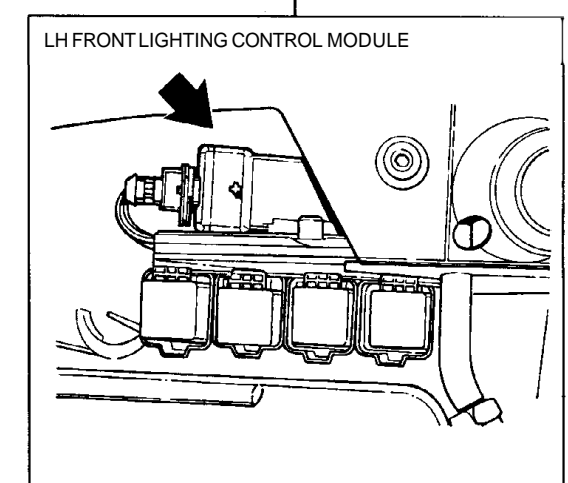
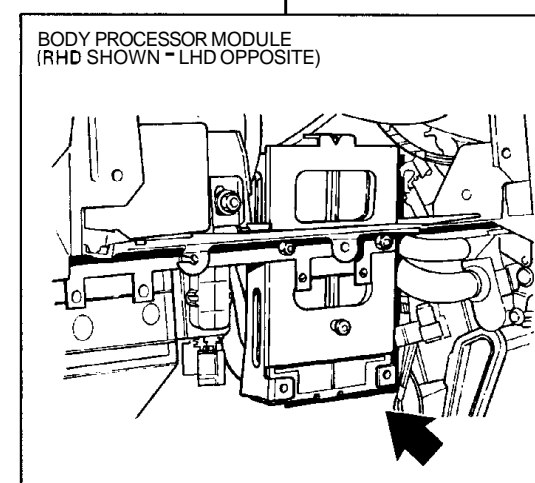
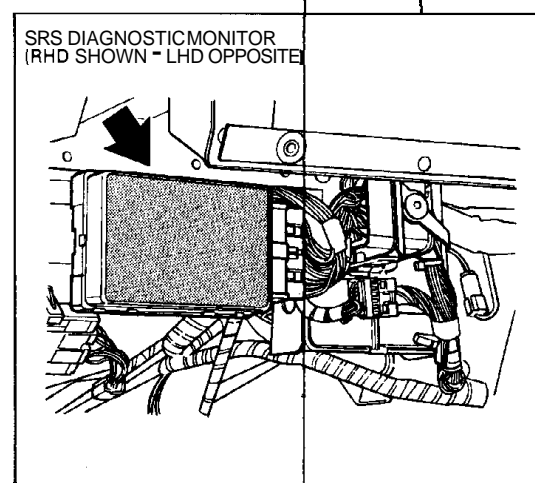
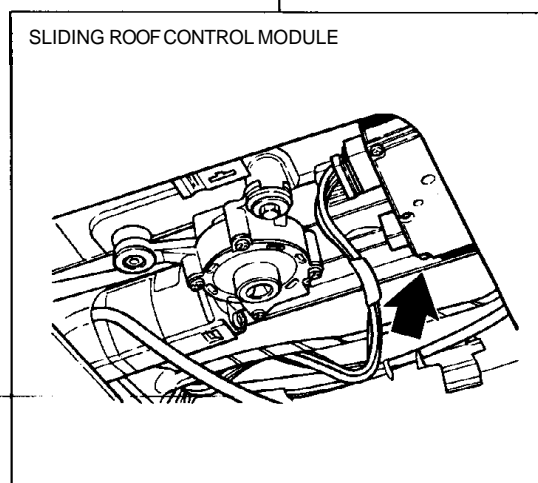
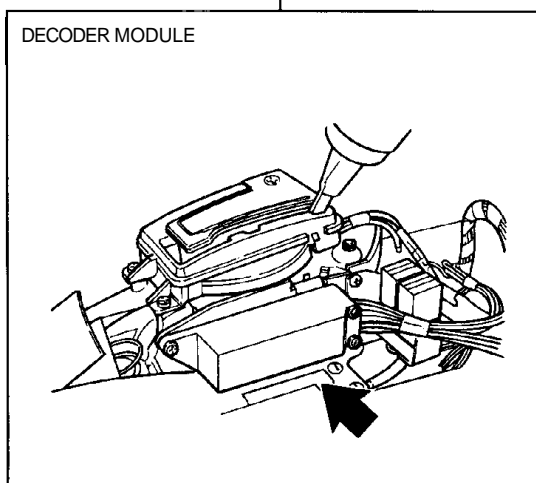
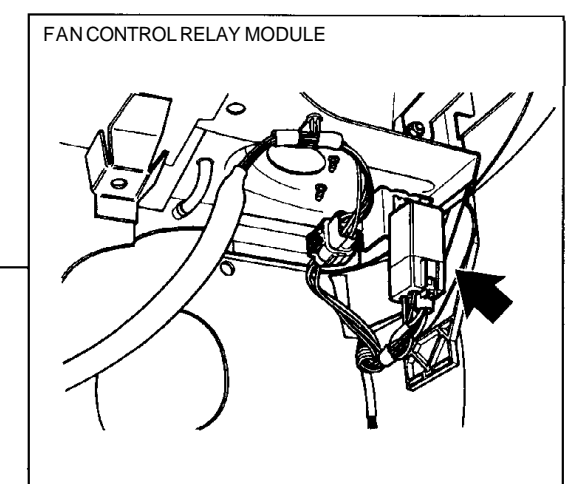
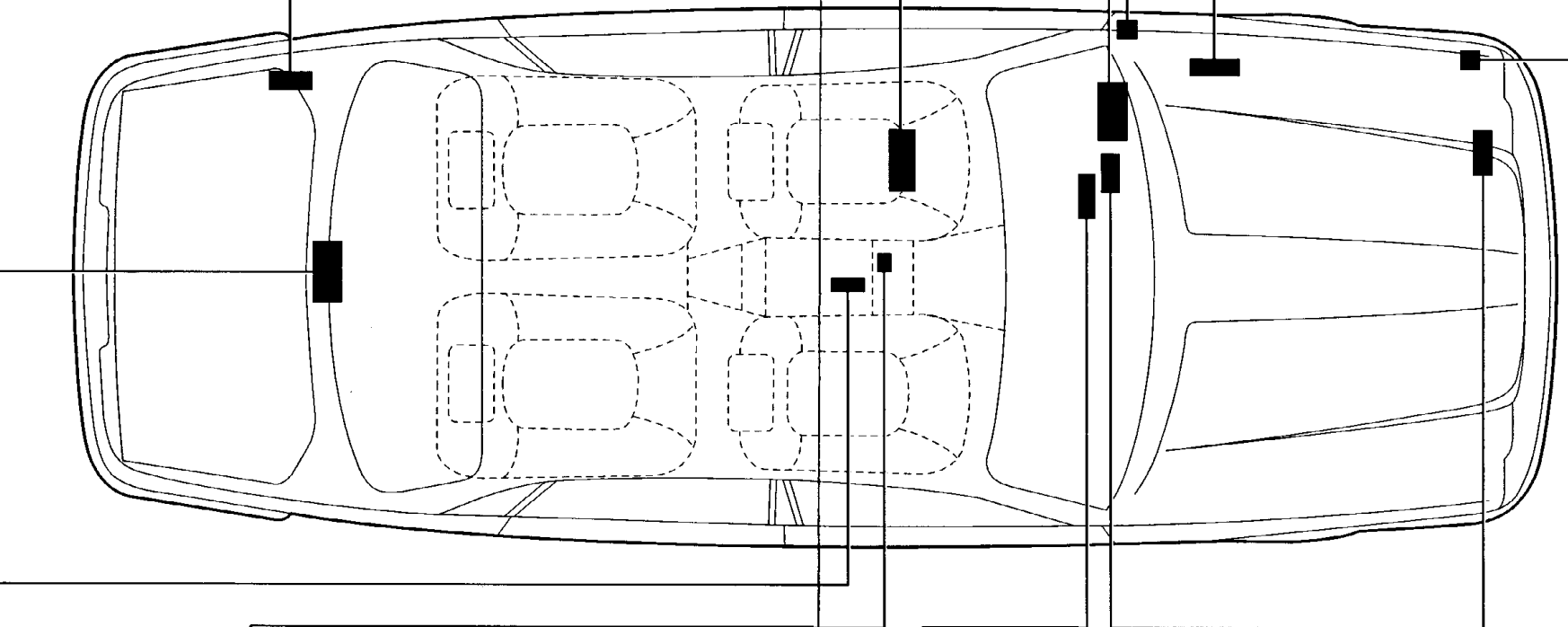
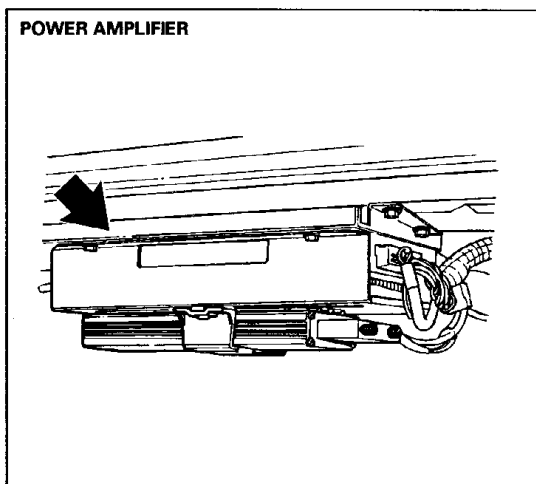
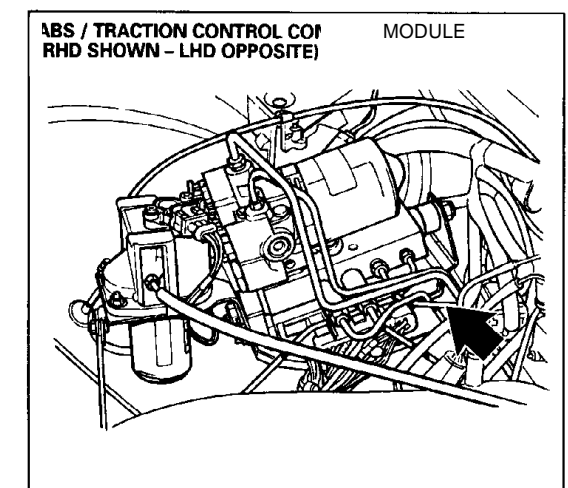
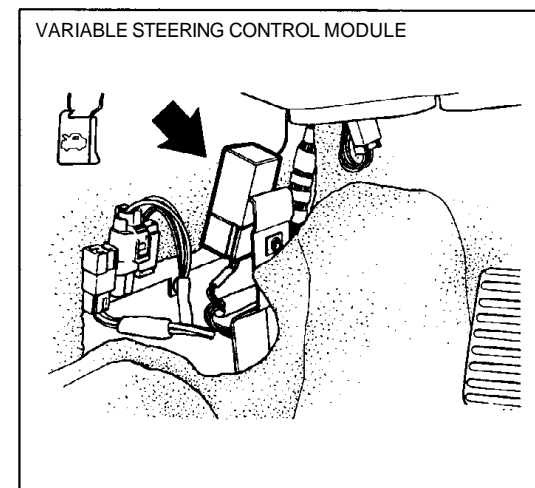
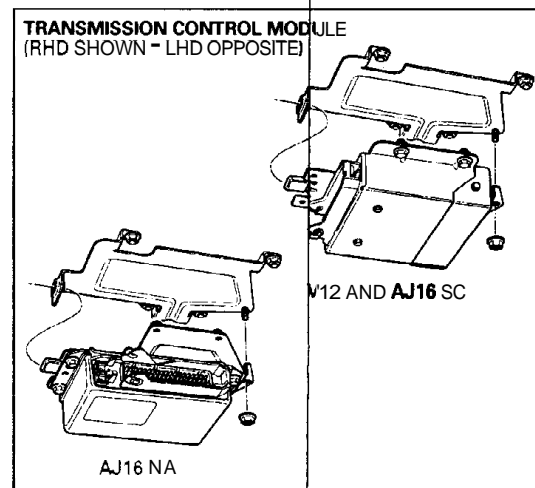
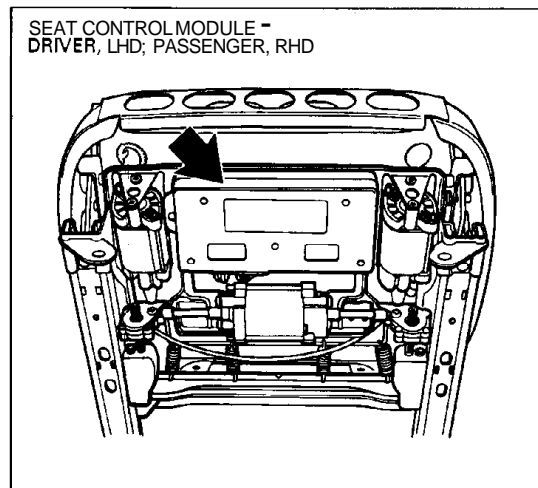
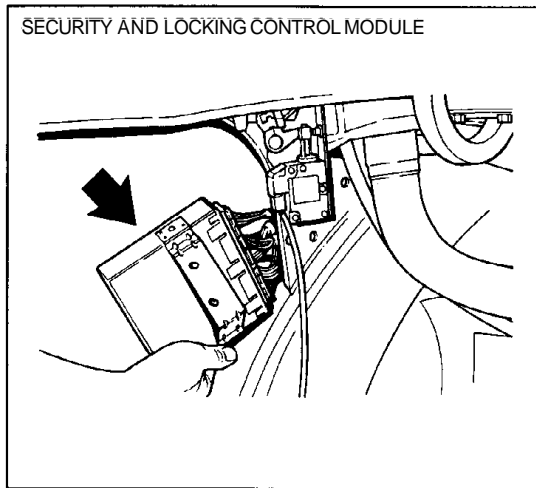

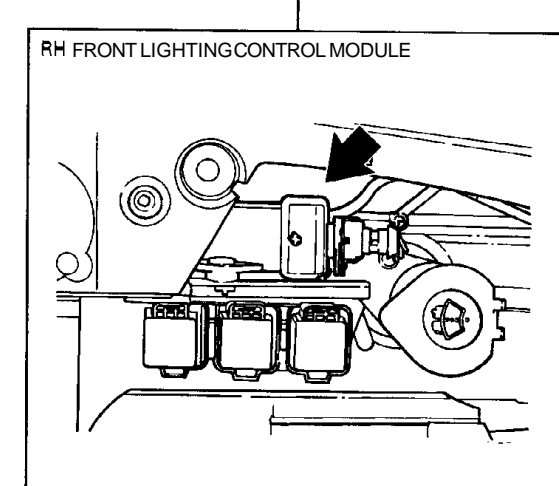
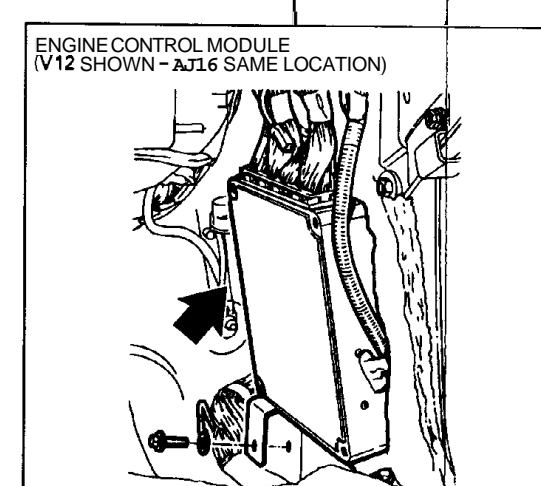
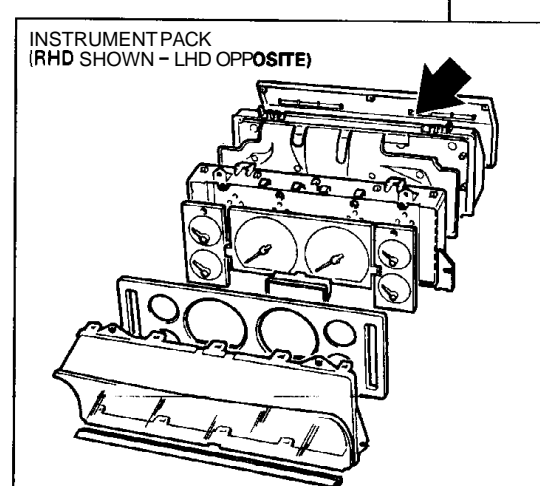
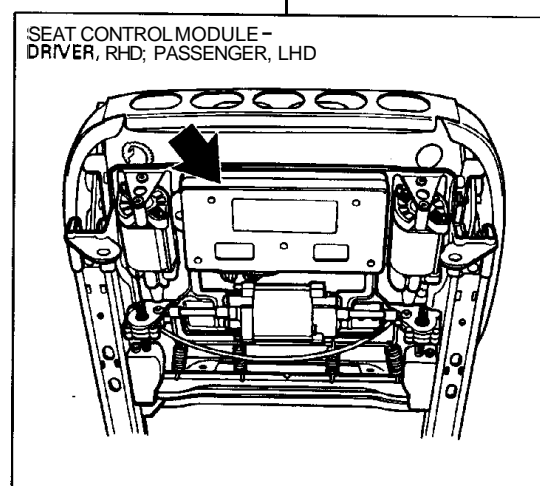
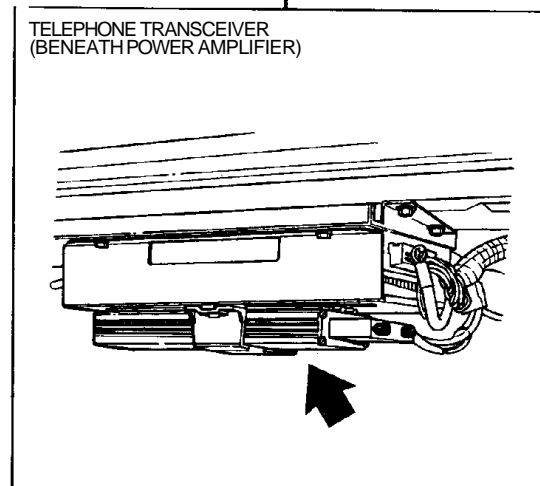
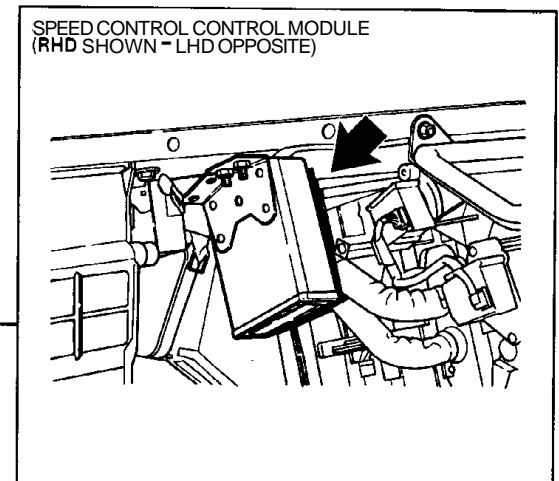
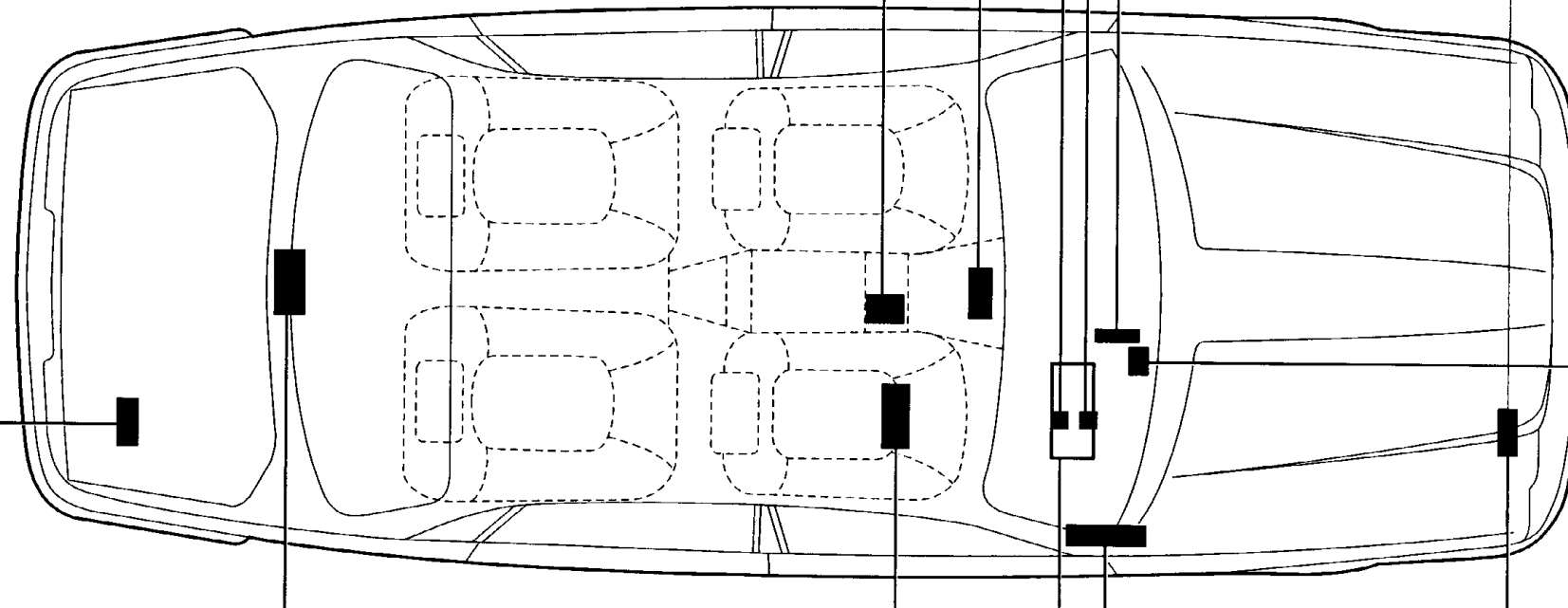
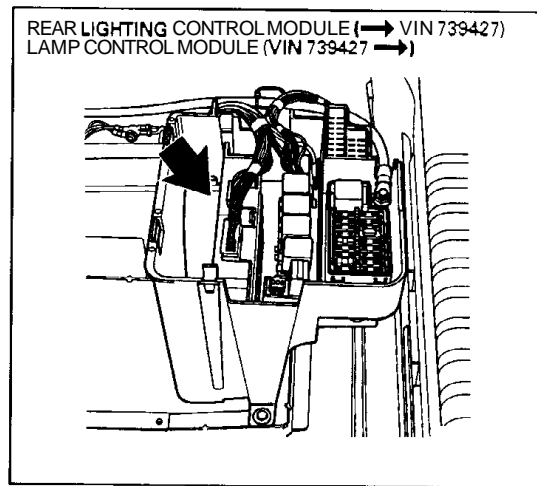
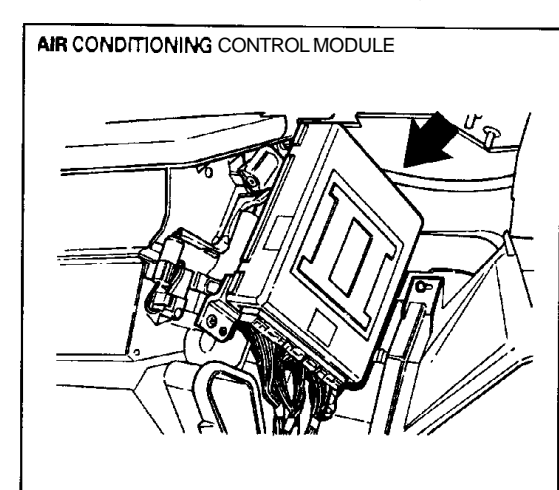
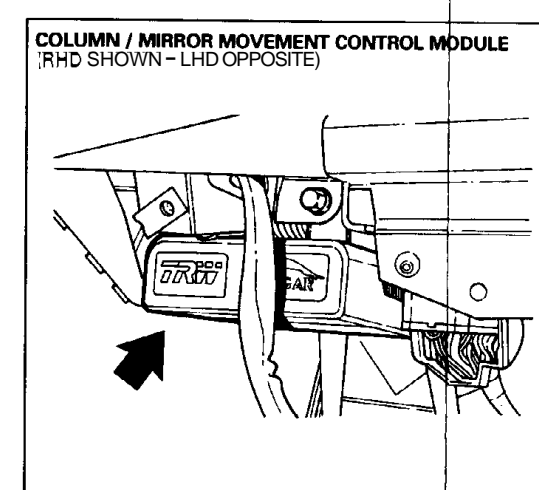
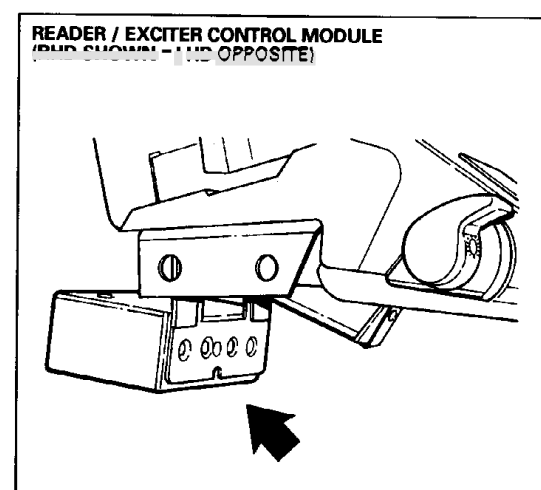
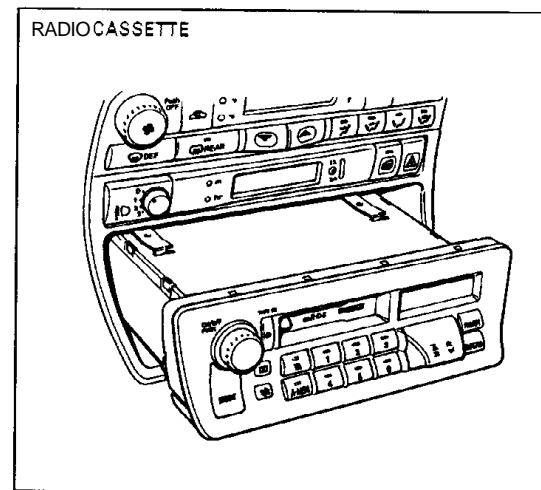
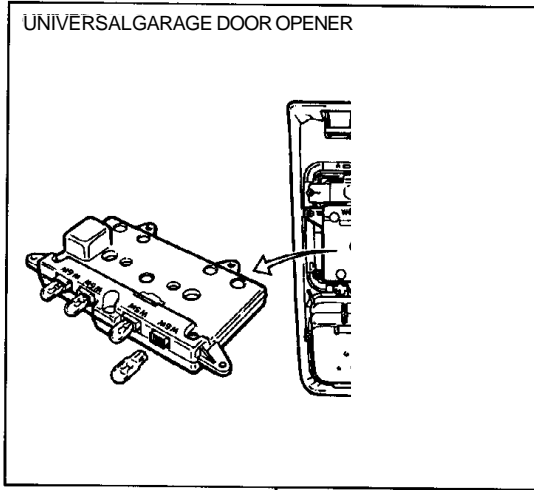



### ENGINE CONTROL MODULE - AJ16

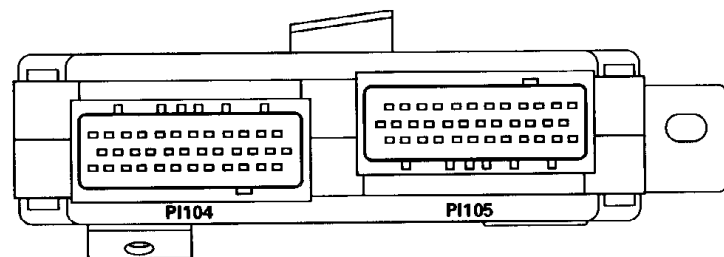

**PI104 / 36-WAY / BLACK (AJ16 NA FEDERAL)**

12	B	11	LGP	10	LGU	9	LGO	8	LGS	7	GB	6	LGK	5	LGR	4	UK	3	OY	2	BU	1	B
24	BLG	23	*	22	PY	21	RY	20	LGB	19	KN	18	NP	17	KR	16	OB	15	BS	14	BG	13	BR
36	B	35	GR	34	PG	33	PW	32	GN	31	—	30	UN	29	OG	28	OR	27	BO	26	*	25	BP

\* → VIN 739427: 23 = W, 26 = O  
VIN 739427 →: 23 = R, 26 = U

**PI104 / 36-WAY / BLACK (AJ16 NA ROW)**

12	B	11	LGP	10	LGU	9	LGO	8	LGS	7	GB	6	LGK	5	LGR	4	UK	3	OY	2	BU	1	B
24	BLG	23	*	22	PY	21	RY	20	LGB	19	KN	18	NP	17	KR	16	OB	15	BS	14	BG	13	BR
36	B	35	—	34	PG	33	PW	32	GN	31	—	30	UN	29	OG	28	OR	27	BO	26	*	25	BP

\* → VIN 739427: 23 = W, 26 = O  
VIN 739427 →: 23 = R, 26 = U

**PI104 / 36-WAY / BLACK (AJ16 SC)**

12	B	11	LGP	10	LGU	9	LGO	8	LGS	7	GB	6	LGK	5	LGR	4	UK	3	OY	2	BU	1	B
24	BLG	23	*	22	PY	21	RY	20	LGB	19	KN	18	NP	17	KR	16	OB	15	BS	14	BG	13	BR
36	B	35	—	34	PG	33	PW	32	GN	31	—	30	UN	29	OG	28	OR	27	BO	26	*	25	BP

\* → VIN 739427: 23 = W, 26 = O  
VIN 739427 →: 23 = R, 26 = U

**PI105 / 36-WAY / RED (AJ16 NA FEDERAL)**

25	—	26	SU	27	RU	28	UP	29	KS	30	BG	31	BN	32	*	33	WK	34	NG	35	GB	36	UN
13	—	14	UY	15	—	16	U	17	BLG	18	R	19	N	20	BW	21	R	22	—	23	—	24	GU
1	UB	2	ULG	3	RN	4	GK	5	—	6	G	7	BG	8	UP	9	U	10	O	11	UW	12	GY

\* → VIN 739427: 32 = W  
VIN 739427 →: 32 = R

**PI105 / 36-WAY / RED (AJ16 NA ROW)**

25	—	26	SU	27	RU	28	UP	29	KS	30	BG	31	BN	32	*	33	WK	34	NG	35	GB	36	UN
13	—	14	UY	15	—	16	U	17	BLG	18	R	19	N	20	BW	21	R	22	—	23	—	24	GU
1	UB	2	ULG	3	—	4	GK	5	—	6	G	7	BG	8	UP	9	U	10	O	11	UW	12	GY

\* → VIN 739427: 32 = W  
VIN 739427 →: 32 = R

**PI105 / 36-WAY / RED (AJ16 SC)**

25	—	26	SU	27	RU	28	UP	29	KS	30	BG	31	BN	32	*	33	WK	34	NG	35	GB	36	UN
13	—	14	UY	15	—	16	U	17	BLG	18	R	19	N	20	BW	21	R	22	—	23	—	24	GU
1	UB	2	ULG	3	—	4	GK	5	—	6	G	7	BG	8	UP	9	U	10	O	11	UW	12	GY

\* → VIN 739427: 32 = W  
VIN 739427 →: 32 = R

### ENGINE CONTROL MODULE - V12

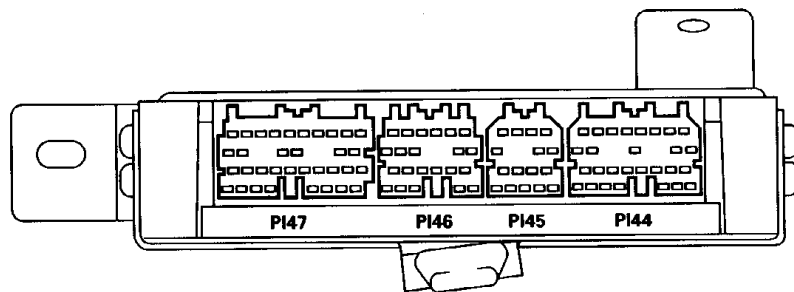

**PI147 / 34-WAY / SLATE**

10	BU	9	BS	8	BN	7	BY	6	BLG	5	BO	4	OR	3	OG	2	OY	1	OB												
16	B	15	—	14	B	13	—	12	KB	11	—	10	—	9	—	8	—	7	—	6	—	5	—	4	—	3	—	2	—	1	—
26	B	25	—	24	—	23	B	22	RN	21	UN	20	GN	19	YN	18	PN	17	ON												
34	PG	33	PN	32	—	31	—	30	—	29	KN	28	B	27	B	26	—	25	—	24	—	23	—	22	—	21	—	20	—	19	—

**PI146 / 22-WAY / SLATE**

6	PU	5	PS	4	PR	3	PO	2	—	1	—
11	B	10	B	9	—	8	W	7	GO	6	—
17	GB	16	RY	15	—	14	R	13	G	12	O
22	B	21	SG	20	SLG	19	U	18	N	17	—

**PI145 / 16-WAY / SLATE**

4	GY	3	OY	2	RW	1	RG		
7	UW	6	UP	5	UY	4	—		
11	R	10	G	9	N	8	—		
16	BG	15	BP	14	B	13	PB	12	*

\* → VIN 739427: 12 = WO  
VIN 739427 →: 12 = WK

**PI144 / 28-WAY / SLATE**

8	—	7	SB	6	SU	5	UG	4	GN	3	PW	2	LGB	1	KR
13	UN	12	ULG	11	—	10	—	9	—	8	—	7	—	6	—
21	BW	20	—	19	—	18	RU	17	—	16	—	15	—	14	GB
28	B	27	—	26	P	25	*	24	NO	23	O	22	K	21	—

\* → VIN 739427: 25 = WO  
VIN 739427 →: 25 = WK

### TRANSMISSION CONTROL MODULE - AJ16 NA

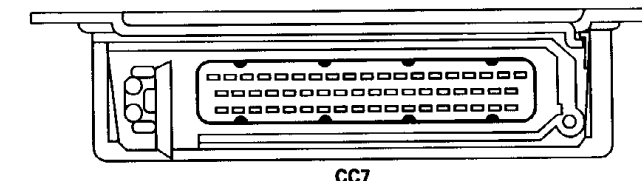

**CC7**

**CC7 / 55-WAY / BLACK**

1	WS	2	R	3	PY	4	RW	5	YB	6	OG	7	B	8	—	9	—	10	—	11	—	12	—	13	—	14	LGP	15	K	16	S	17	—	18	—	19	RY																																		
20	BRD	21	PW	22	—	23	—	24	YP	25	—	26	B	27	—	28	—	29	RP	30	—	31	—	32	SU	33	LGW	34	—	35	—	36	—	37	—	38	—	39	—	40	—	41	BS	42	YU	43	—	44	BG	45	—	46	YG	47	GN	48	—	49	GU	50	LGB	51	O	52	—	53	—	54	—	55	—

### TRANSMISSION CONTROL MODULE - V12 AND AJ16 SC

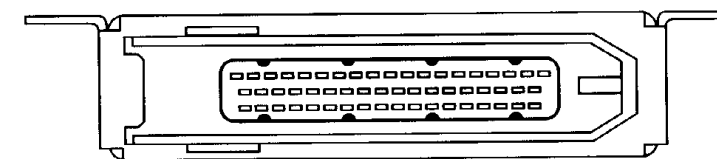

**CC48**

**CC48 / 55-WAY / BLACK (AJ16 SC)**

1	—	2	—	3	OK	4	OU	5	RW	6	P	7	SU	8	—	9	—	10	—	11	GN	12	PW	13	—	14	BU	15	—	16	K	17	—	18	—	19	—
20	—	21	—	22	ON	23	RP	24	BS	25	PU	26	OY	27	—	28	—	29	—	30	PY	31	—	32	—	33	—	34	—	35	—	36	U	37	G		
38	—	39	OR	40	S	41	GU	42	OW	43	OP	44	—	45	O	46	—	47	—	48	—	49	OS	50	N	51	R	52	OB	53	WS	54	B	55	NR		

**CC48 / 55-WAY / BLACK (V12)**

1	—	2	—	3	OK	4	OU	5	RW	6	P	7	SU	8	—	9	—	10	—	11	GN	12	PW	13	—	14	BU	15	—	16	K	17	—	18	—	19	—
20	—	21	—	22	ON	23	RP	24	BS	25	PU	26	OY	27	—	28	—	29	—	30	PY	31	—	32	—	33	—	34	—	35	—	36	U	37	G		
38	—	39	OR	40	S	41	GU	42	OW	43	OP	44	—	45	O	46	—	47	—	48	—	49	OS	50	N	51	R	52	OB	53	WS	54	B	55	NR		

### DECODER MODULE

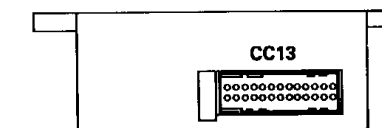

**CC13**

**CC13 / 26-WAY / BLUE**

14	SR	15	SP	16	—	17	—	18	—	19	—	20	B	21	B	22	—	23	SB	24	RU	25	—	26	—
1	SW	2	SU	3	SG	4	SY	5	—	6	—	7	—	8	—	9	—	10	WS	11	LGP	12	LGW	13	—



ABS / TRACTION CONTROL CONTROL MODULE

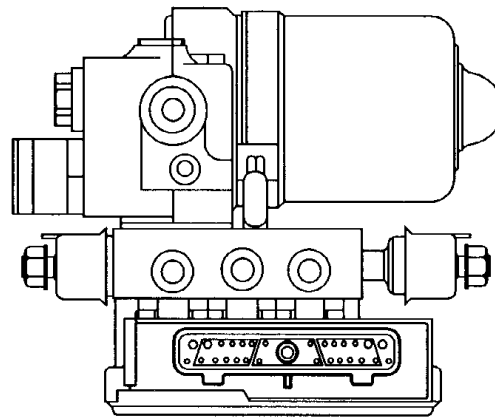

LHD - RS27; RHD - LS27

RS27, LS27 / 28-WAY / SLATE

14	13	12	11	10	9	8	7	6	5	4	3	2	1
B	B	BS	BW	BK	BR	BY	BO	BG	BU	SR	RP	NO	NS
28	27	26	25	24	23	22	21	20	19	18	17	16	15
O	P	U	Y	GK	RG	B	RB	PU	—	RN	N	S	WR

SPEED CONTROL CONTROL MODULE

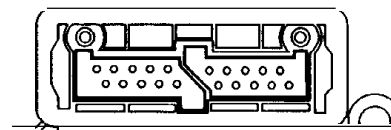

FC17

FC17 / 20-WAY / BLACK

1	2	3	4	5	6	7	8	9	10
WU	—	PG	—	—	UP	—	—	SR	UR
11	12	13	14	15	16	17	18	19	20
B	PY	—	UG	PU	—	SU	SB	—	UY

SRS DIAGNOSTIC MONITOR

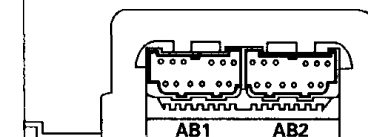

AB1 / 12-WAY / SLATE

6	5	4	3	2	1
YU	B	YW	B	ON	LGS
12	11	10	9	8	7
KG	KU	RG	RN	—	RW

AB2 / 12-WAY / BLACK

6	5	4	3	2	1
YG	RP	KN	KP	RP	—
12	11	10	9	8	7
—	YP	—	OW	OP	—

FRONT LIGHTING CONTROL MODULE

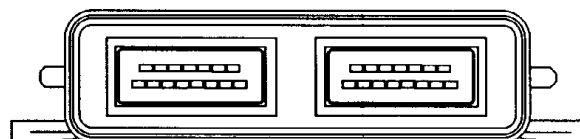

LH - LS13; RH - RS13 LH - LS30; RH - RS30

LS13 / 15-WAY / BROWN

9	10	11	12	13	14	15	
RO	RO	NY	R	UW	US	NK	
1	2	3	4	5	6	7	8
UY	—	—	—	UK	KY	WR	NO

LS30 / 15-WAY / BLACK

9	10	11	12	13	14	15	
YK	RO	G	GY	YS	—	KU	
1	2	3	4	5	6	7	8
NG	R	B	—	KR	—	KS	—

RS13 / 15-WAY / BROWN

9	10	11	12	13	14	15	
RO	RO	NY	R	UW	US	NK	
1	2	3	4	5	6	7	8
UY	—	—	—	UK	KU	WU	NO

RS30 / 15-WAY / BLACK

9	10	11	12	13	14	15	
YK	RO	G	GY	YU	—	KR	
1	2	3	4	5	6	7	8
NG	R	B	—	KG	—	KS	—

REAR LIGHTING CONTROL MODULE (VIN 739427)

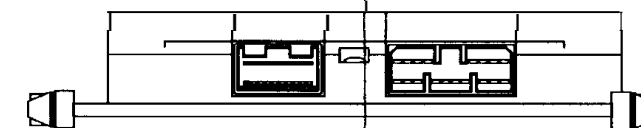

BT21

BT20

BT21 / 20-WAY / BLACK

10	9	8	7	6	5	4	3	2	1
YU	R	KR	KG	RW	PW	RS	RB	—	—
20	19	18	17	16	15	14	13	12	11
—	—	B	WS	KS	RU	RU	SLG	PU	YS

BT20 / 18-WAY / WHITE

8	7	6	5	4	3	2	1		
NR	NLG	RG	PG	NLG	YG	UG	NR		
18	17	16	15	14	13	12	11	10	9
KU	KR	GP	GU	RY	PY	GO	GN	Y	U

LAMP CONTROL MODULE (VIN 739427)

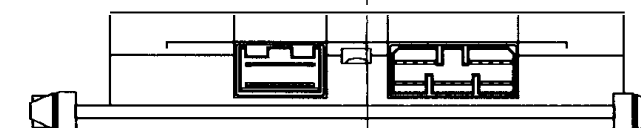

BT21

BT20

BT21 / 20-WAY / BLACK

10	9	8	7	6	5	4	3	2	1
PG	RG	UG	PW	KR	YU	—	YO	YG	YK
20	19	18	17	16	15	14	13	12	11
RK	WS	KU	R	KG	YS	PU	KS	SLG	RU

BT20 / 18-WAY / WHITE

8	7	6	5	4	3	2	1		
GO	GU	NY	NG	Y	GP	GY	PY		
18	17	16	15	14	13	12	11	10	9
NP	NO	G	GW	U	B	NLG	NK	GN	NU



AIR CONDITIONING CONTROL MODULE

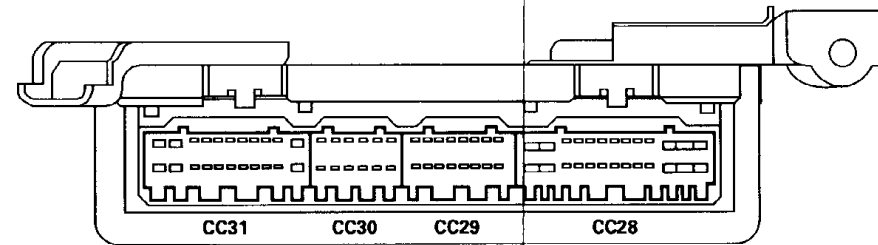

CC31 / 22-WAY / SLATE

12	13	14	15	16	17	18	19	20	21	22
WR	B	B	GW	UP	UB	LGW	BW	BK	O	—
1	2	3	4	5	6	7	8	9	10	11
WP	GY	WN	WU	NY	PY	—	P	UN	K	PW

CC30 / 12-WAY / SLATE (AJ16 NA)

7	8	9	10	11	12
SY	SR	—	B	UB	KU
1	2	3	4	5	6
ULG	S	SG	—	OY	UG

CC29 / 16-WAY / SLATE

9	10	11	12	13	14	15	16
OU	OR	YG	UY	—	—	UK	GP
1	2	3	4	5	6	7	8
OP	RG	YW	—	SU	SG	US	GO

CC28 / 26-WAY / SLATE

14	15	16	17	18	19	20	21	22	23	24	25	26
KR	KS	LGW	RW	LGP	RU	SR	Y	NR	—	—	UR	GU
1	2	3	4	5	6	7	8	9	10	11	12	13
RLG	U	UY	PS	KW	RY	PR	PY	RB	—	—	UW	UO

CC30 / 12-WAY / SLATE (AJ16 SC)

7	8	9	10	11	12
SY	SR	—	W	UB	KU
1	2	3	4	5	6
ULG	S	SG	—	OY	UG

CC30 / 12-WAY / SLATE (V12)

7	8	9	10	11	12
SY	SR	—	—	UB	KU
1	2	3	4	5	6
ULG	S	SG	SB	OY	UG

COLUMN / MIRROR MOVEMENT CONTROL MODULE

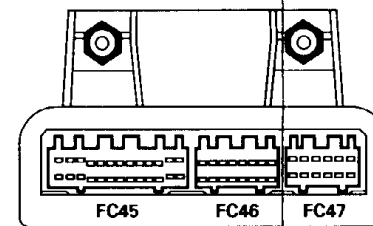

FC45 / 26-WAY / SLATE

13	12	11	10	9	8	7	6	5	4	3	2	1
OG	PLG	ON	OB	SN	OR	YN	YR	SK	PU	—	PR	PN
26	25	24	23	22	21	20	19	18	17	16	15	14
BS	PG	WU	WN	UR	—	KS	UN	UP	US	WG	BP	BR

FC46 / 16-WAY / SLATE

8	7	6	5	4	3	2	1
US	YB	SLG	PS	YQ	OK	YK	OU
16	15	14	13	12	11	10	9
—	—	—	—	—	KN	PG	OY

FC47 / 12-WAY / SLATE

6	5	4	3	2	1
NO	O	K	—	B	NB
12	11	10	9	8	7
—	—	—	—	—	—

BODY PROCESSOR MODULE

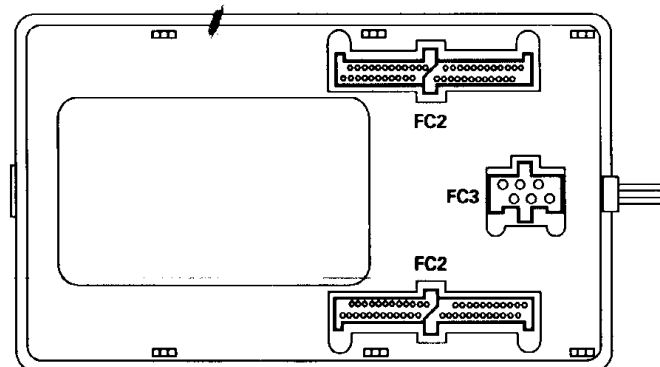

FC2 / 48-WAY / BLACK

1	2	3	4	5	6	7	8	9	10	11	12
RY	SK	ULG	UP	RO	PO	LGB	—	—	KR	—	OP
25	26	27	28	29	30	31	32	33	34	35	36
BO	LGP	YR	YLG	GR	P	WY	RY	PR	KG	PU	—
13	14	15	16	17	18	19	20	21	22	23	24
—	—	—	—	—	—	—	—	—	—	—	—
37	38	39	40	41	42	43	44	45	46	47	48
PG	OP	LGG	OLG	RW	KU	RLG	KY	PLG	YN	LGR	UR

FC3 / 6-WAY / BLACK

1	2	3
NB	—	O
4	5	6
K	B	B

FC1 / 48-WAY / YELLOW

1	2	3	4	5	6	7	8	9	10	11	12
—	—	—	—	—	—	—	—	—	—	—	—
25	26	27	28	29	30	31	32	33	34	35	36
RW	SP	YP	OG	UK	UO	BU	UP	RO	LGY	US	YB
13	14	15	16	17	18	19	20	21	22	23	24
W	R	OP	GY	YS	RO	YU	—	GR	GB	OW	RLG
37	38	39	40	41	42	43	44	45	46	47	48
BN	YP	*	LGN	*	OW	—	—	RU	Y	RU	—

\* → VIN 739427: 39 = UK, 41 = US  
VIN 739427 → 39 = US, 41 = UK



NOTE: RELAY COLORS ARE WRITTEN AS CASE COLOR (STRIPE) / CONNECTOR COLOR. FOR EXAMPLE, BLACK (BLUE) / BLUE INDICATES A RELAY HAVING A BLACK CASE WITH A BLUE STRIPE AND A BLUE CONNECTOR. IF THERE IS NO COLOR SHOWN IN PARENTHESES, THE RELAY CASE DOES NOT HAVE A STRIPE.

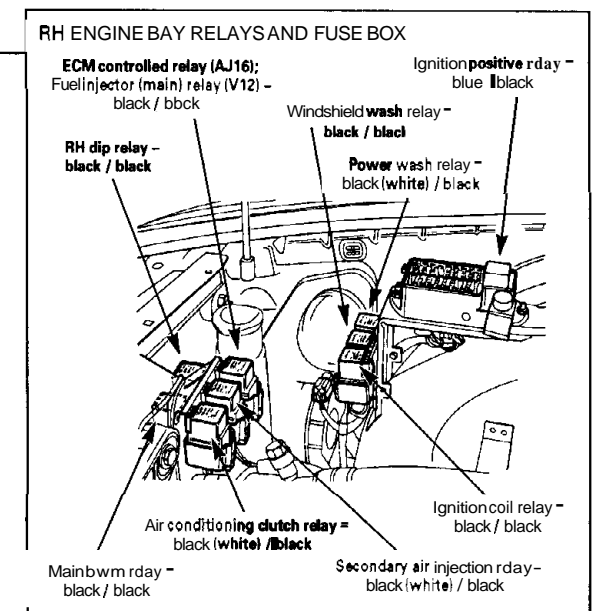
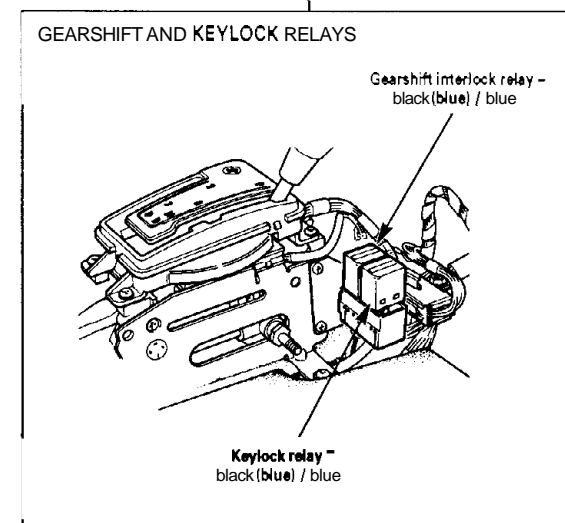
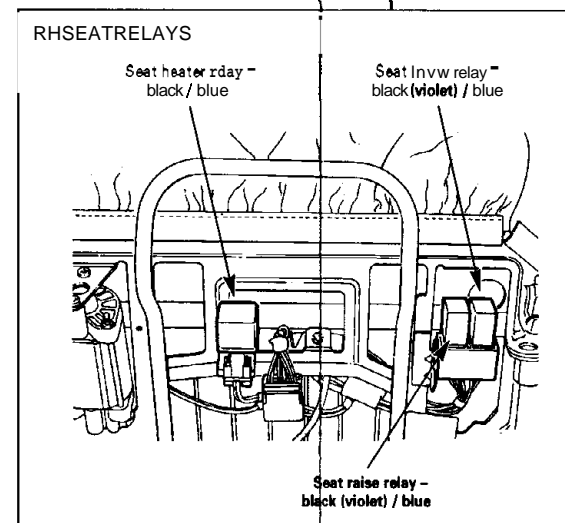
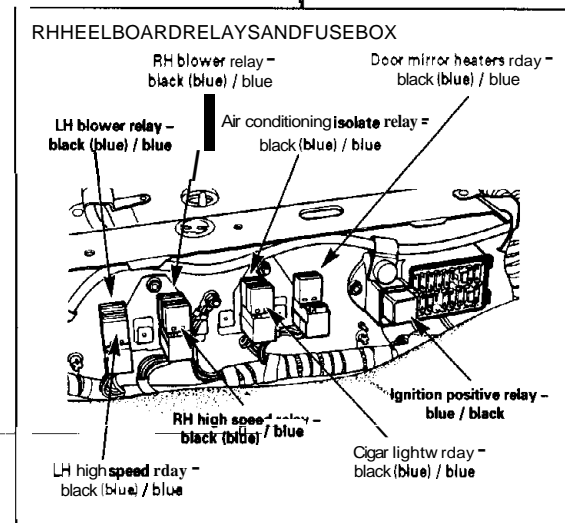
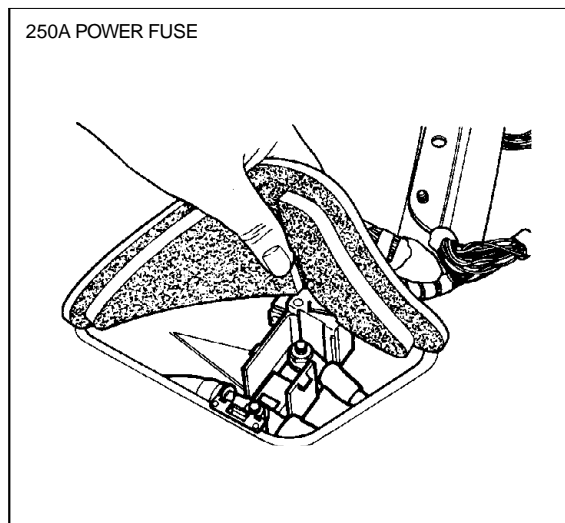
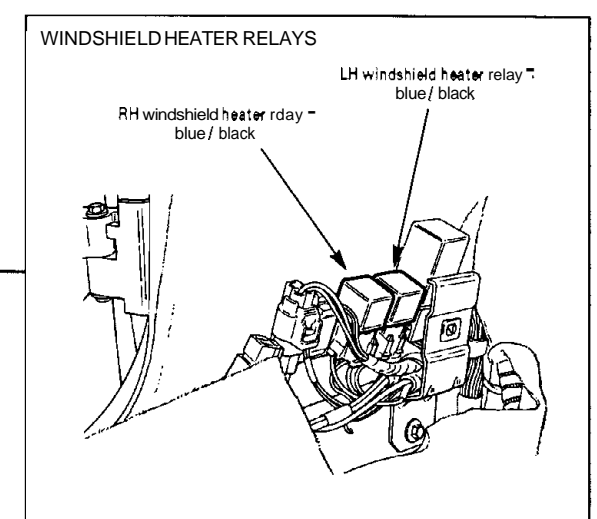
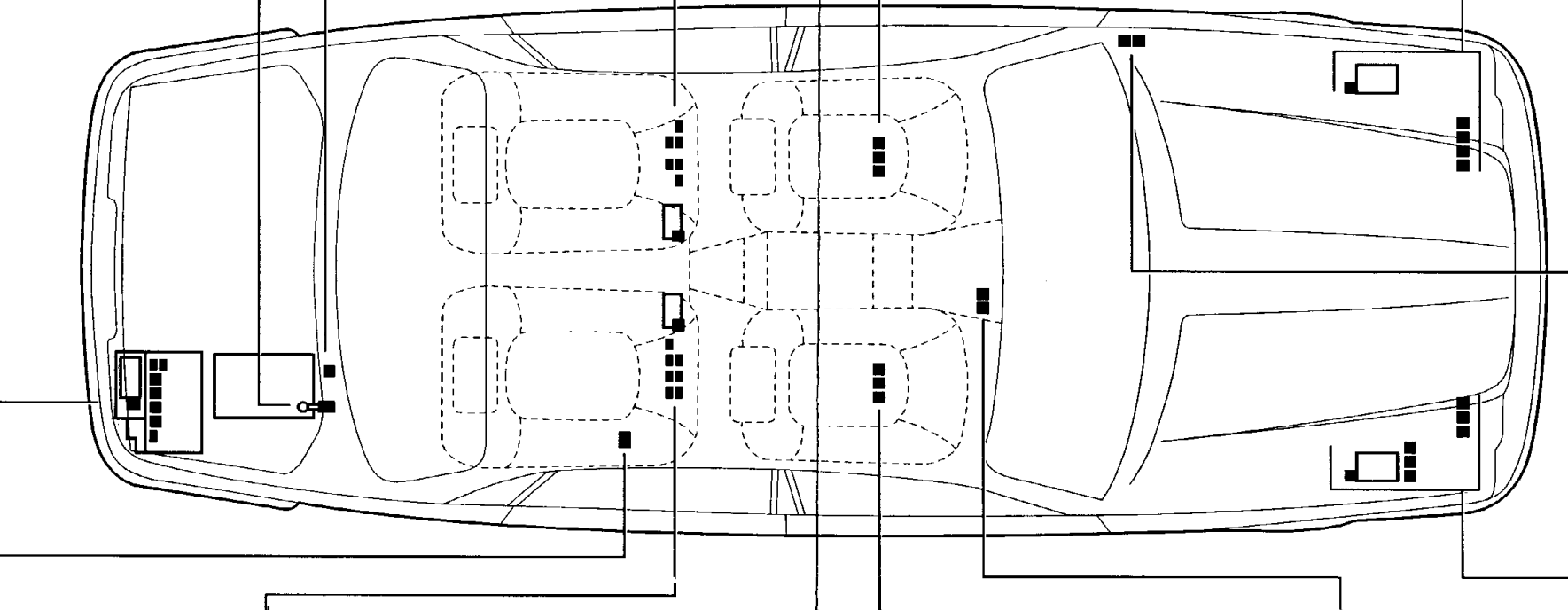
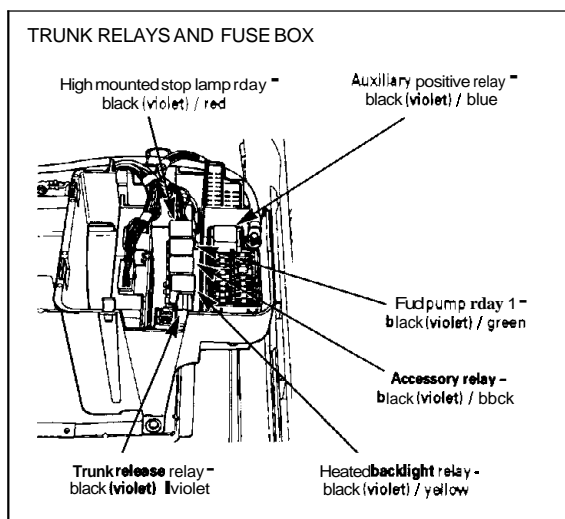
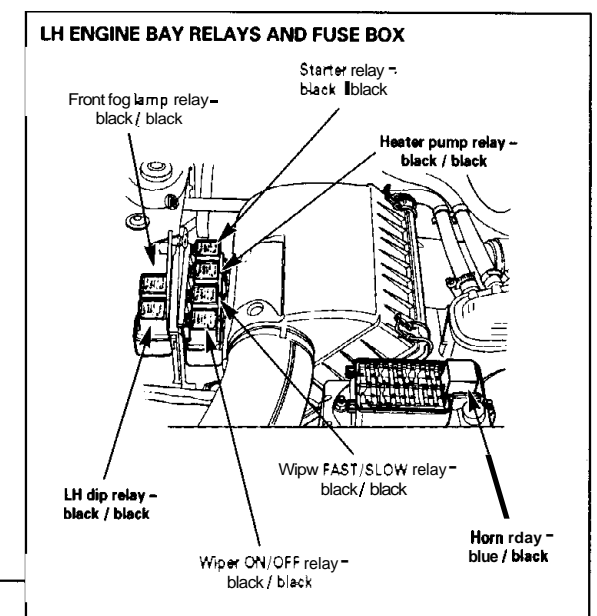
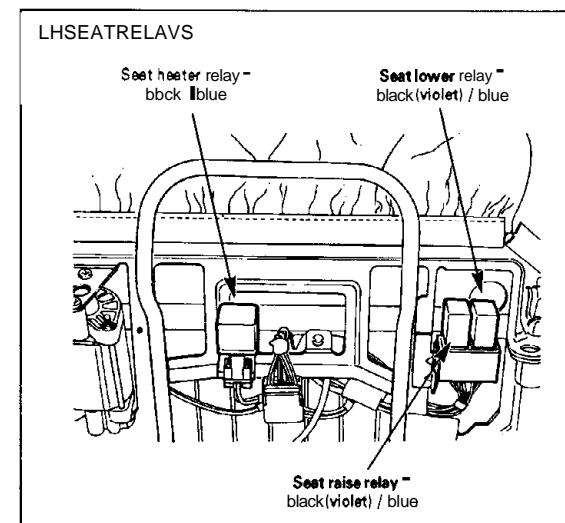
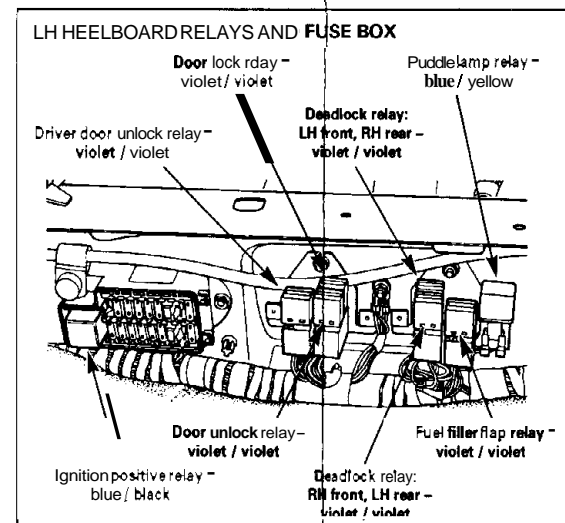
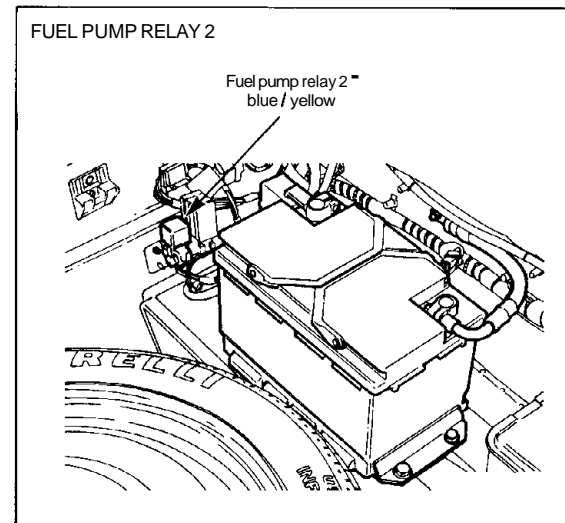
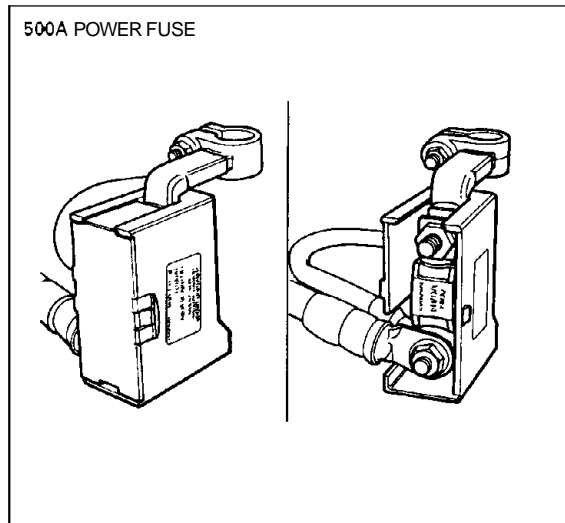

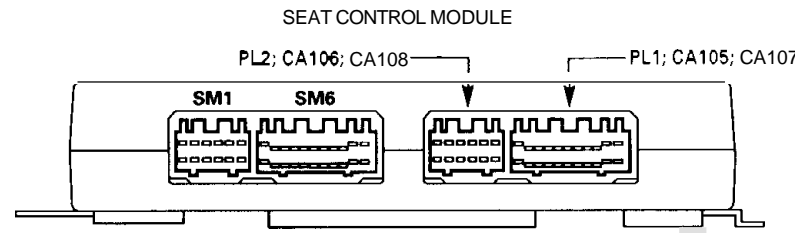

**SM1-D / 12-WAY / WHITE**

6	5	4	3	2	1
KO	KS	UO	US	RO	RS
12	11	10	9	8	7
GO	GS	R	B	PS	PO

**SM6-D / 22-WAY / WHITE**

11	10	9	8	7	6	5	4	3	2	1
GN	PY	PW	RY	WU	WO	WY	WR	WP	WB	W
22	21	20	19	18	17	16	15	14	13	12
—	—	RW	UW	UY	KW	KY	GW	GY	—	—

**PL2-D, CA106 / 12-WAY / BLUE**

6	5	4	3	2	1
NLG	—	NG	—	K	O
12	11	10	9	8	7
NS	—	—	—	—	NO

**PL1-D, CA105 / 22-WAY / BLUE**

11	10	9	8	7	6	5	4	3	2	1
WP	—	YB	UG	—	US	UP	JN	WN	—	—
22	21	20	19	18	17	16	15	14	13	12
PG	KS	—	—	PU	—	BO	UR	OY	US	KN

**SM1-P / 12-WAY / WHITE**

6	5	4	3	2	1
KO	KS	UO	US	RO	RS
12	11	10	9	8	7
GO	GS	R	B	PS	PO

**SM6-P / 22-WAY / WHITE**

11	10	9	8	7	6	5	4	3	2	1
GN	PY	PW	RY	WU	WO	WY	WR	WP	WB	W
22	21	20	19	18	17	16	15	14	13	12
—	—	RW	UW	UY	KW	KY	GW	GY	—	—

**PL2-P, CA108 / 12-WAY / BLUE**

6	5	4	3	2	1
NLG	—	NG	—	K	O
12	11	10	9	8	7
NS	—	—	—	—	NO

**PL1-P, CA107 122-WAY / BLUE**

11	10	9	8	7	6	5	4	3	2	1
WP	—	YB	UG	—	US	UP	JN	WN	—	—
22	21	20	19	18	17	16	15	14	13	12
UO	KS	—	—	PU	—	BO	UR	OY	US	KN

SECURITY AND LOCKING CONTROL MODULE

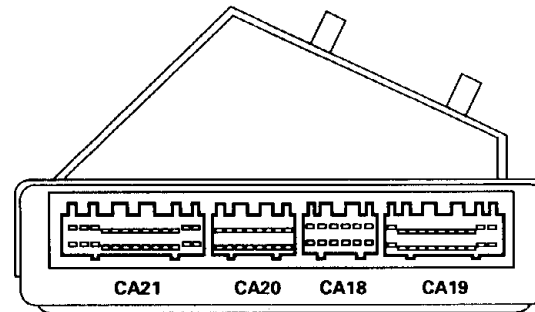

**CA21 / 26-WAY / SLATE**

13	12	11	10	9	8	7	6	5	4	3	2	1
WB	NU	PW	RO	LGP	UP	OY	YO	U	—	—	PLG	OW
26	25	24	23	22	21	20	19	18	17	16	15	14
WO	B	GU	SK	YLG	UN	GB	S	—	—	—	OY	OR

**CA20 / 16-WAY / SLATE**

8	7	6	5	4	3	2	1
O	BRD	—	RW	R	UW	BRD	—
16	15	14	13	12	11	10	9
K	WN	B	RB	U	UB	BRD	—

**CA18 / 12-WAY / SLATE (LHD)**

6	5	4	3	2	1
OU	OR	YR	US	RG	UO
12	11	10	9	8	7
OY	OW	YR	SW	WN	PR

**CA19 / 22-WAY / SLATE**

11	10	9	8	7	6	5	4	3	2	1
SR	GP	UW	PG	LGS	YW	—	—	—	—	R
22	21	20	19	18	17	16	15	14	13	12
PO	P	RY	SG	UR	WO	—	—	—	PO	KN

**CA18 / 12-WAY / SLATE (RHD)**

6	5	4	3	2	1
OU	OR	YR	US	RG	UO
12	11	10	9	8	7
OY	OW	YB	SW	WN	PR

INSTRUMENT PACK

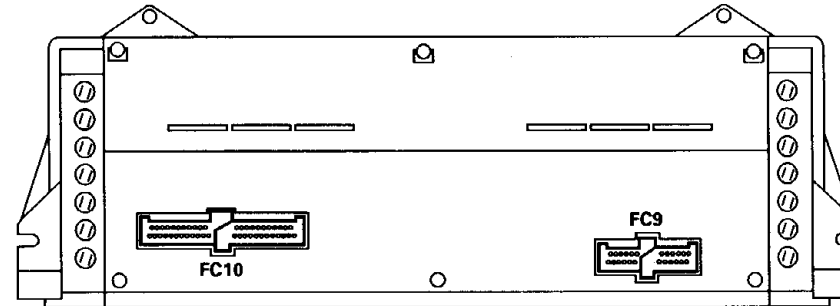

**FC10 / 48-WAY / BLACK**

1	2	3	4	5	6	7	8	9	10	11	12	13	14	15	16	17	18	19	20	21	22	23	24
—	U	UP	SU	—	—	—	—	SW	BY	—	O	OR	GU	SP	RY	OY	Y	—	—	—	LGB	UR	UP
25	26	27	28	29	30	31	32	33	34	35	36	37	38	39	40	41	42	43	44	45	46	47	48
—	—	—	—	—	—	—	—	—	—	RG	Y	OP	B	—	YP	YG	R	KS	S	YW	G	P	—

**FC9 / 24-WAY / BLACK**

1	2	3	4	5	6	7	8	9	10	11	12
KR	WO	B	B	NR	LGS	RB	—	—	RO	—	—
13	14	15	16	17	18	19	20	21	22	23	24
O	K	GK	—	—	—	OK	BW	OS	SG	—	PY

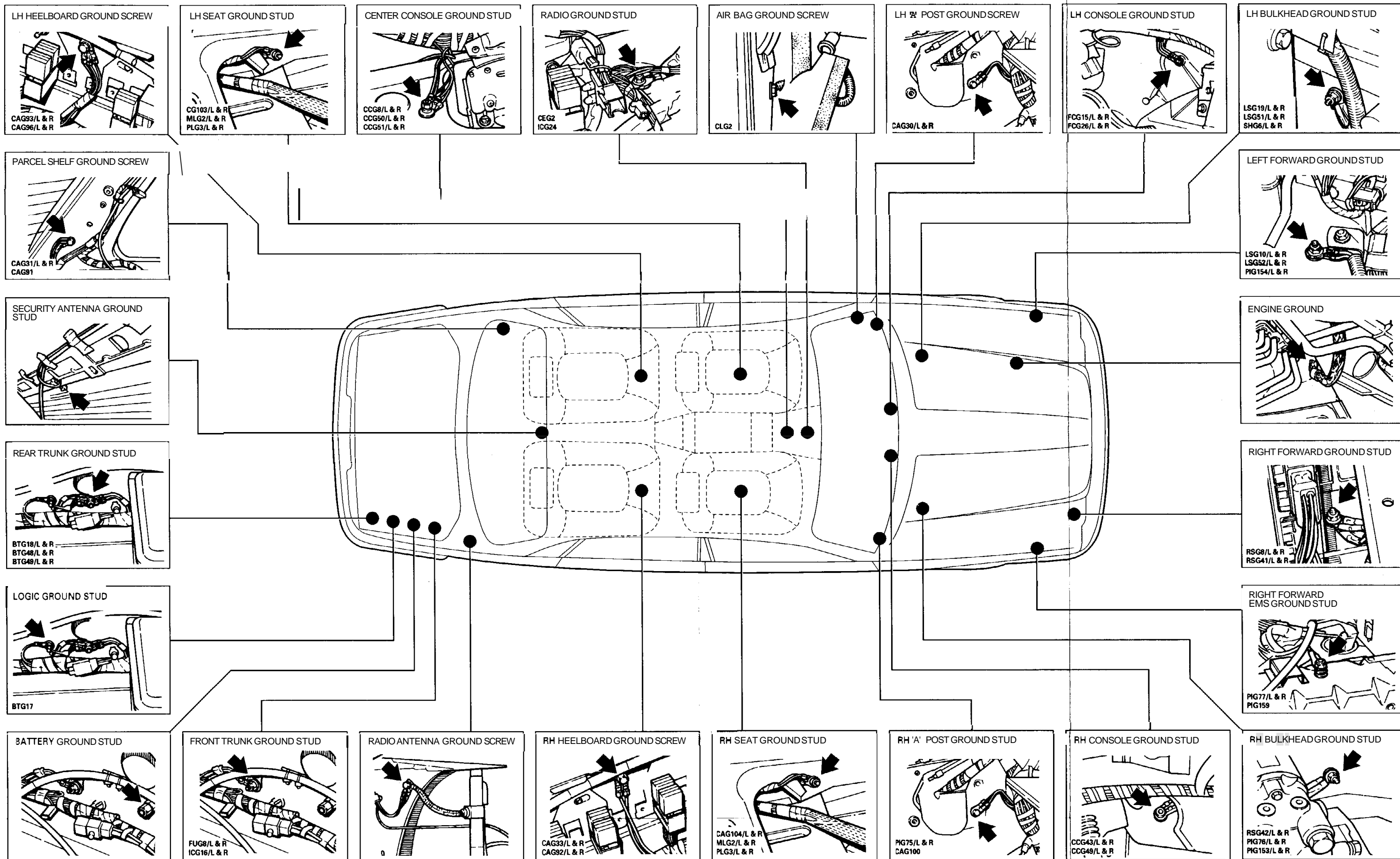

LH HEELBOARD GROUND SCREW

CAG93/L & R  
CAG96/L & R

LH SEAT GROUND STUD

CG103/L & R  
MLG2/L & R  
PLG3/L & R

CENTER CONSOLE GROUND STUD

CCG8/L & R  
CCG50/L & R  
CCG51/L & R

RADIO GROUND STUD

CEG2  
ICG24

AIR BAG GROUND SCREW

CLG2

LH 'A' POST GROUND SCREW

CAG30/L & R

LH CONSOLE GROUND STUD

FCG15/L & R  
FCG26/L & R

LH BULKHEAD GROUND STUD

LSG19/L & R  
LSG51/L & R  
SHG6/L & R

PARCEL SHELF GROUND SCREW

CAG31/L & R  
CAG91

SECURITY ANTENNA GROUND STUD

REAR TRUNK GROUND STUD

BTG18/L & R  
BTG48/L & R  
BTG49/L & R

LOGIC GROUND STUD

BTG17

BATTERY GROUND STUD

FRONT TRUNK GROUND STUD

FUG8/L & R  
ICG16/L & R

RADIO ANTENNA GROUND SCREW

RH HEELBOARD GROUND SCREW

CAG33/L & R  
CAG92/L & R

RH SEAT GROUND STUD

CAG104/L & R  
MLG2/L & R  
PLG3/L & R

RH 'A' POST GROUND STUD

PIG75/L & R  
CAG100

RH CONSOLE GROUND STUD

CCG43/L & R  
CCG49/L & R

RH BULKHEAD GROUND STUD

RSG42/L & R  
PIG76/L & R  
PIG153/L & R

LEFT FORWARD GROUND STUD

LSG10/L & R  
LSG52/L & R  
PIG154/L & R

ENGINE GROUND

RIGHT FORWARD GROUND STUD

RSG8/L & R  
RSG41/L & R

RIGHT FORWARD EMS GROUND STUD

PIG77/L & R  
PIG159



CONTROL MODULE PIN OUT INFORMATION

BODY PROCESSOR MODULE

Pin	Description	Active	Inactive
O FC1-13	TRANSIT ISOLATION DEVICE	GROUND	B+
I FC2-31	IGNITION SWITCHED GROUND	GROUND	B+

The following symbols are used to represent values for Control Module Pin Out data:

I Input	B+ Battery voltage
O output	V Voltage (DC)
SG Signal Ground	Hz Frequency
D Serial and encoded communications	KHz Frequency x 1000
	MS Milliseconds
	MV Millivolts

CAUTION The information on this data page is furnished to aid the user in understanding circuit operation. THIS INFORMATION SHOULD BE USED FOR REFERENCE ONLY.

NOTE: The values listed are approximately those that can be expected at the control module connector pins with all circuit connections made and all components connected and fitted. "Active" means a load is applied or a switch is ON; "Inactive" means a load is not applied or a switch is OFF.

Fig. 0

COMPONENTS

Component	Connector Type Color	Location Access
BATTERY	STB ST10	TRUNK
BODY PROCESSOR MODULE	FC1 / 48-WAY PCB SIGNAL / YELLOW FC2 / 48-WAY PCB SIGNAL BLACK FC3 / 6-WAY PCB SIGNAL BLACK	PASSENGERS UNDERSCUTTLE
FUSE BOX - LH ENGINE BAY	LS1 / 10-WAY UTA BLACK LS37 / 10-WAY UTA BLACK	ENGINE BAY, LH FRONT
FUSE BOX - RH ENGINE BAY	RS1 / 10-WAY UTA / BLACK RS6 / 10-WAY UTA / BLACK	ENGINE BAY, RH FRONT
FUSE BOX - LH HEELBOARD	CA1 / 10-WAY UTA / NATURAL CAP / 10-WAY UTA BLACK	LH HEELBOARD
FUSE BOX - RH HEELBOARD	CA36 / 10-WAY UTA / NATURAL CA44 / 10-WAY UTA / BLACK	RH HEELBOARD
FUSE BOX - TRUNK	BT9 / 10-WAY UTA / BLACK BT35 / 10-WAY UTA / NATURAL	TRUNK ELECTRICAL CARRIER

RELAYS

Relay	Color / Stripe	Connector Color	Location Access
AUXILIARY POSITIVE RELAY (TRUNK FUSE BOX)	BLACK / VIOLET	- / BLUE	TRUNK FUSE BOX
HORN RELAY (LH ENGINE BAY FUSE BOX)	BLUE	- / BLACK	LH ENGINE BAY FUSE BOX
IGNITION POSITIVE RELAY (LH HEELBOARD FUSE BOX)	BLUE	- / BLACK	LH HEELBOARD FUSE BOX
IGNITION POSITIVE RELAY (RH HEELBOARD FUSE BOX)	BLUE	- / BLACK	RH HEELBOARD FUSE BOX
IGNITION POSITIVE RELAY (RH ENGINE BAY FUSE BOX)	BLUE	- / BLACK	RH ENGINE BAY FUSE BOX
TRANSIT ISOLATION DEVICE	-	BT37 / -	BATTERY POSITIVE POST

HARNESS-TO-HARNESS CONNECTORS

Connector	Type / Color	Location Access
BT4	THROUGH PANEL (48 MICRO / 61) BLACK	PARCEL SHELF FUEL TANK TRIM
FC16	PO-WAY MULTILOCK 040 / BLACK	PASSENGERS UNDERSCUTTLE
FC6	THROUGH-PANEL (48 MICRO / 61) BLACK	RH FASCIA END PANEL / OUTER AIR VENT

GROUNDS

Ground	Location Type
FCG15L	LH CONSOLE GROUND STUD
ST9	BATTERY GROUND STUD

CONTROL MODULE PIN OUT INFORMATION (FOLD OUT PAGE)



REFER TO THE FRONT OF THE BOOK FOR ILLUSTRATIONS DETAILING THE LOCATION AND IDENTIFICATION OF COMPONENTS, RELAYS, CONNECTORS, HARNESSES, GROUNDS, VEHICLE CONTROL MODULES AND CONTROL MODULE PINS.

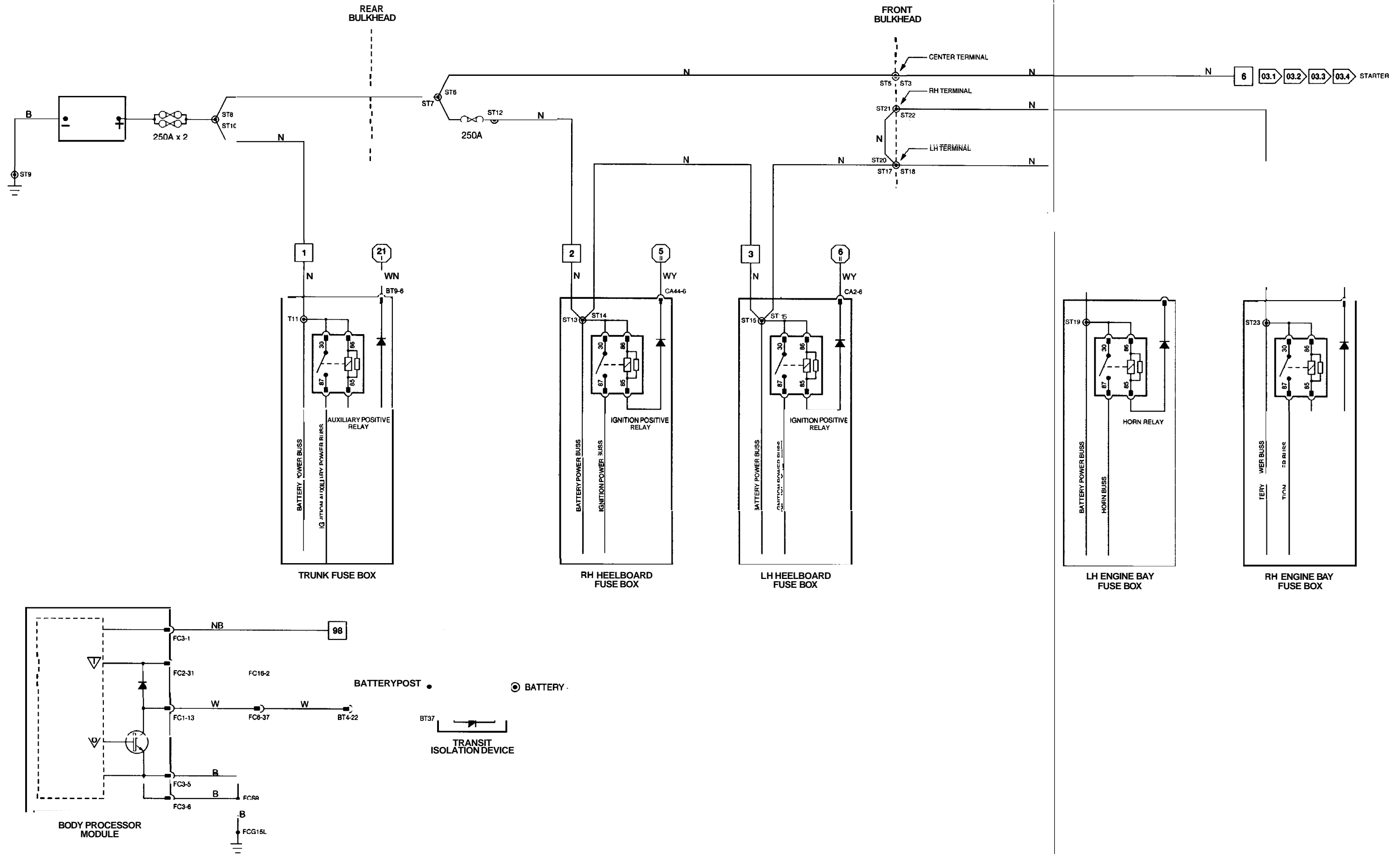

**Fig. 01.2**

**COMPONENTS**

<b>Component</b>	<b>Connector / Type / Color</b>	<b>Location / Access</b>
FUSE BOX - LH HEELBOARD	CA1 / 10-WAY UTA / NATURAL CA2 / 10-WAY UTA / BLACK	RH HEELBOARD
FUSE BOX - RH HEELBOARD	CA36 / 10-WAY UTA / NATURAL CA44 / 10-WAY UTA / BLACK	

**HARNESS-TO-HARNESSCONNECTORS**

<b>Connector</b>	<b>Type / Color</b>	<b>Location / Access</b>
CC18	20-WAY MULTILOCK M O / BLUE	CENTER CONSOLE/CENTER CONSOLE
FC7	THROUGH-PANEL (48 MICRO / 6) / BLACK	PASSENGERS UNDERSCUTTLE

REFER TO THE FRONT OF THE BOOK FOR ILLUSTRATIONS DETAILING THE LOCATION AND IDENTIFICATION OF COMPONENTS, RELAYS, CONNECTORS, HARNESES, GROUNDS. VEHICLE CONTROL MODULES AND CONTROL MODULE PINS.

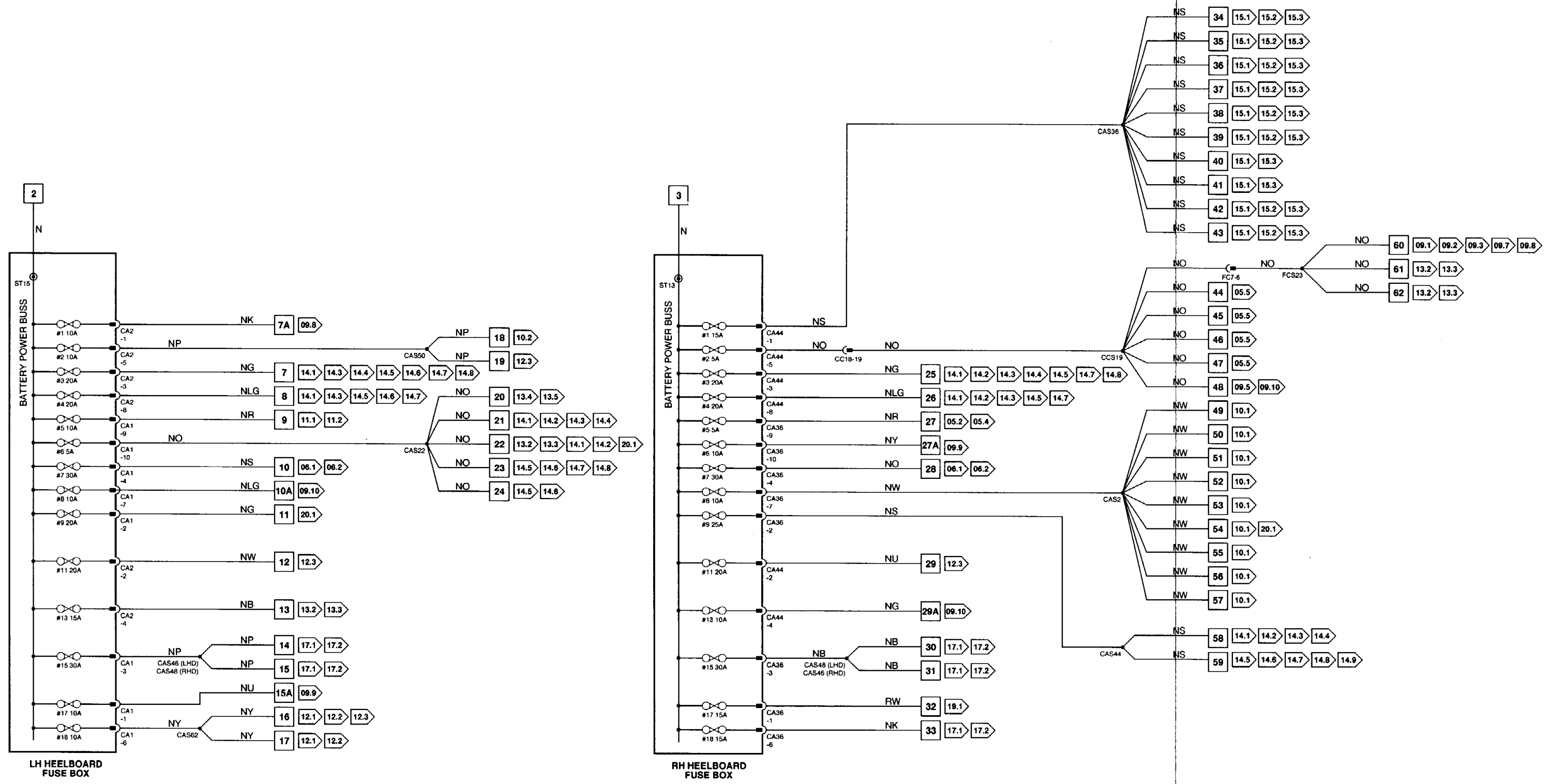

**Fig. 01.3****COMPONENTS****Component**

FUSE BOX-LH ENGINE BAY

FUSE BOX-RH ENGINE BAY

FUSE BOX-TRUNK

**Connector / Type / Color**

LS1 / 10-WAY UTA / BLACK

LS37 / 10-WAY UTA / BLACK

RS1 / 10-WAY UTA / BLACK

RS6 / 10-WAY UTA / BLACK

BT9 / 10-WAY UTA / BLACK

BT35 / 10-WAY UTA / NATURAL

**Location / Access**

ENGINE BAY, LH FRONT

ENGINE BAY, RH FRONT

TRUNK ELECTRICAL CARRIER

**HARNESS-TO-HARNESS CONNECTORS****Connector**

BT4

CC4

FC7

**Type / Color**

THROUGH-PANEL (48 MICRO / 6) / BLACK

14-WAY MULTILOCK 070 / WHITE

THROUGH-PANEL (48 MICRO / 6) / BLACK

**Location / Access**

PARCEL SHELF / FUEL TANK TRIM

CENTER CONSOLE / CENTER CONSOLE GLOVE BOX

PASSENGERS UNDERSCUTTLE

REFER TO THE FRONT OF THE BOOK FOR ILLUSTRATIONS DETAILING THE LOCATION AND IDENTIFICATION OF COMPONENTS, RELAYS, CONNECTORS, HARNESSES, GROUNDS, VEHICLE CONTROL MODULES AND CONTROL MODULE PINS.

DATE OF ISSUE **JANUARY 1995**

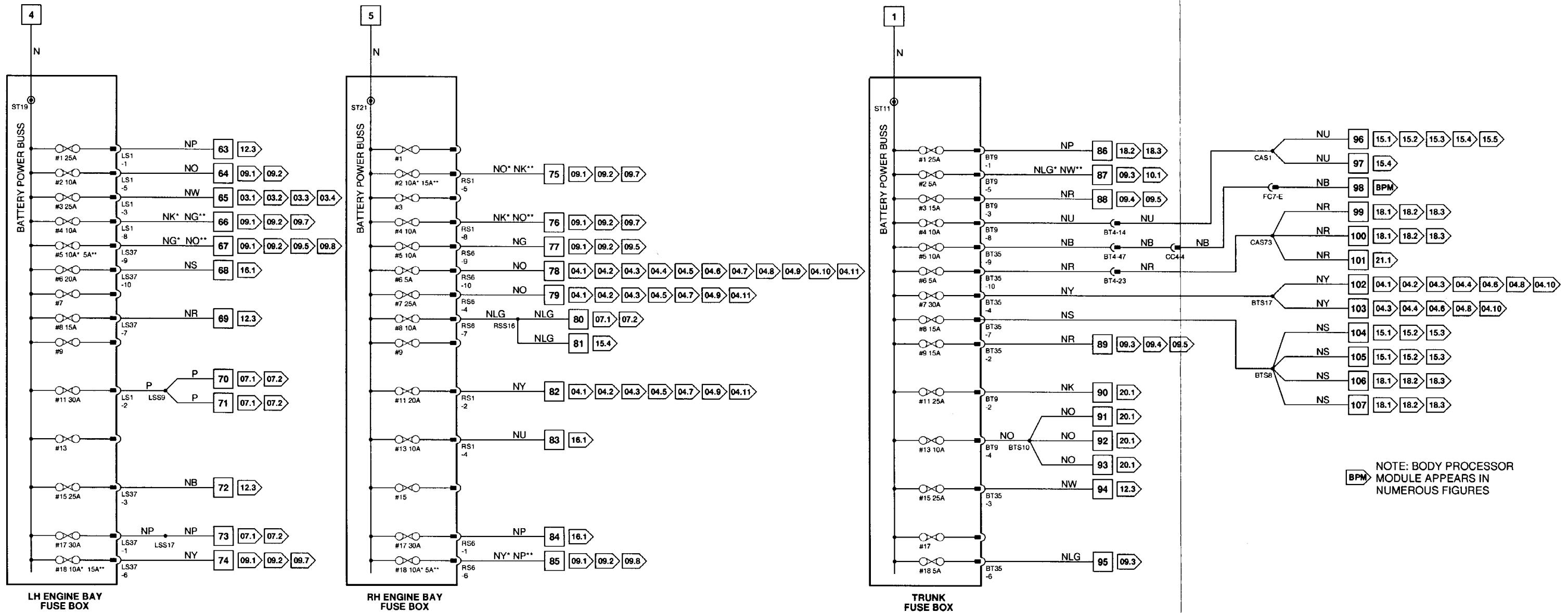

NOTE: FUSE RATING AND/OR WIRE COLOR CODE CHANGE  
 \* -> VIN 739427  
 \*\* -> VIN 739427 ->

NOTE: FUSE RATING AND/OR WIRE COLOR CODE CHANGE  
 \* -> VIN 739427  
 \*\* -> VIN 739427 ->

NOTE: FUSE RATING AND/OR WIRE COLOR CODE CHANGE  
 \* -> VIN 739427  
 \*\* -> VIN 739427 ->

NOTE: BODY PROCESSOR MODULE APPEARS IN NUMEROUS FIGURES

**Fig. 01.4****COMPONENTS**

Component	Connector / Type / Color	Location / Access
FUSE BOX - RH ENGINE BAY	RS1 / 10-WAY UTA / BLACK RS6 / 10-WAY UTA / BLACK	ENGINE BAY, RH FRONT
FUSE BOX - LH HEELBOARD	CA1 / 10-WAY UTA / NATURAL CA2 / 10-WAY UTA / BLACK	LH HEELBOARD
FUSE BOX - RH HEELBOARD	CA36 / 10-WAY UTA / NATURAL CA44 / 10-WAY UTA / BLACK	RH HEELBOARD
FUSE BOX - TRUNK	BT9 / 10-WAY UTA / BLACK BT35 / 10-WAY UTA / NATURAL	TRUNK ELECTRICAL CARRIER

**RELAYS**

Relay	Color / Stripe	Connector / Color	Location / Access
AUXILIARY POSITIVE RELAY (TRUNK FUSE BOX)	BLACK / VIOLET	- / BLUE	TRUNK FUSE BOX
IGNITION POSITIVE RELAY (LH HEELBOARD FUSE BOX)	BLUE	- / BLACK	LH HEELBOARD FUSE BOX
IGNITION POSITIVE RELAY (RH HEELBOARD FUSE BOX)	BLUE	- / BLACK	RH HEELBOARD FUSE BOX
IGNITION POSITIVE RELAY (RH ENGINE BAY FUSE BOX)	BLUE	- / BLACK	RH ENGINE BAY FUSE BOX

**HARNESS-TO-HARNESS CONNECTORS**

Connector	Type / Color	Location / Access
BT4	THROUGH-PANEL (48 MICRO / 6) / BLACK	PARCEL SHELF (FUEL TANK) TRIM
LS3	THROUGH-PANEL (48 MICRO / 6) / BLACK	LH 'A' POST / 'A' POST PANEL
PI61	13-WAY ECONOSEAL III LC / BLACK	RH AIR CLEANER
SH8	4-WAY MULTILOCK 070 / WHITE	LH 'A' POST / 'A' POST PANEL

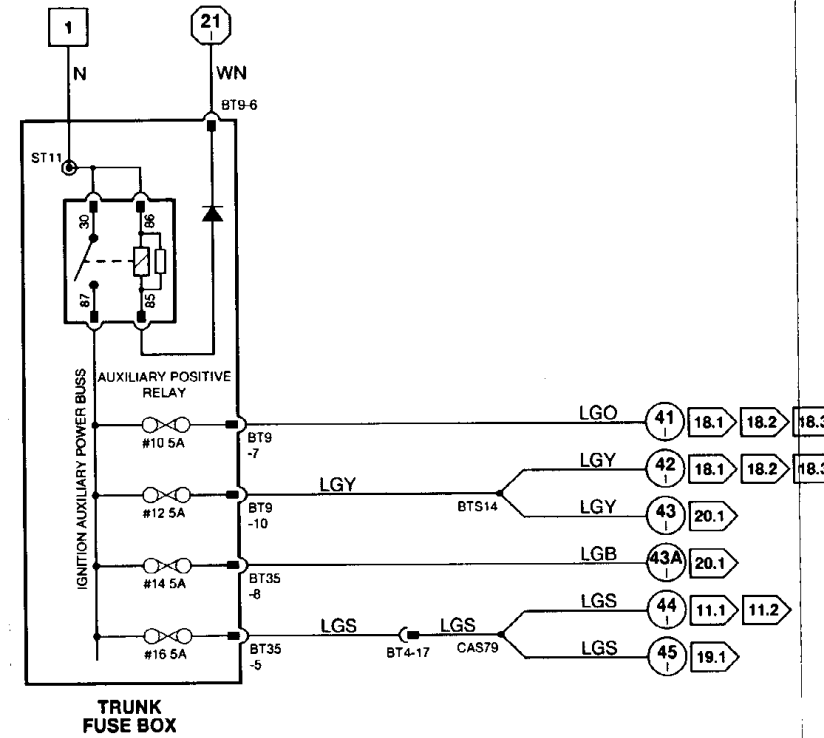
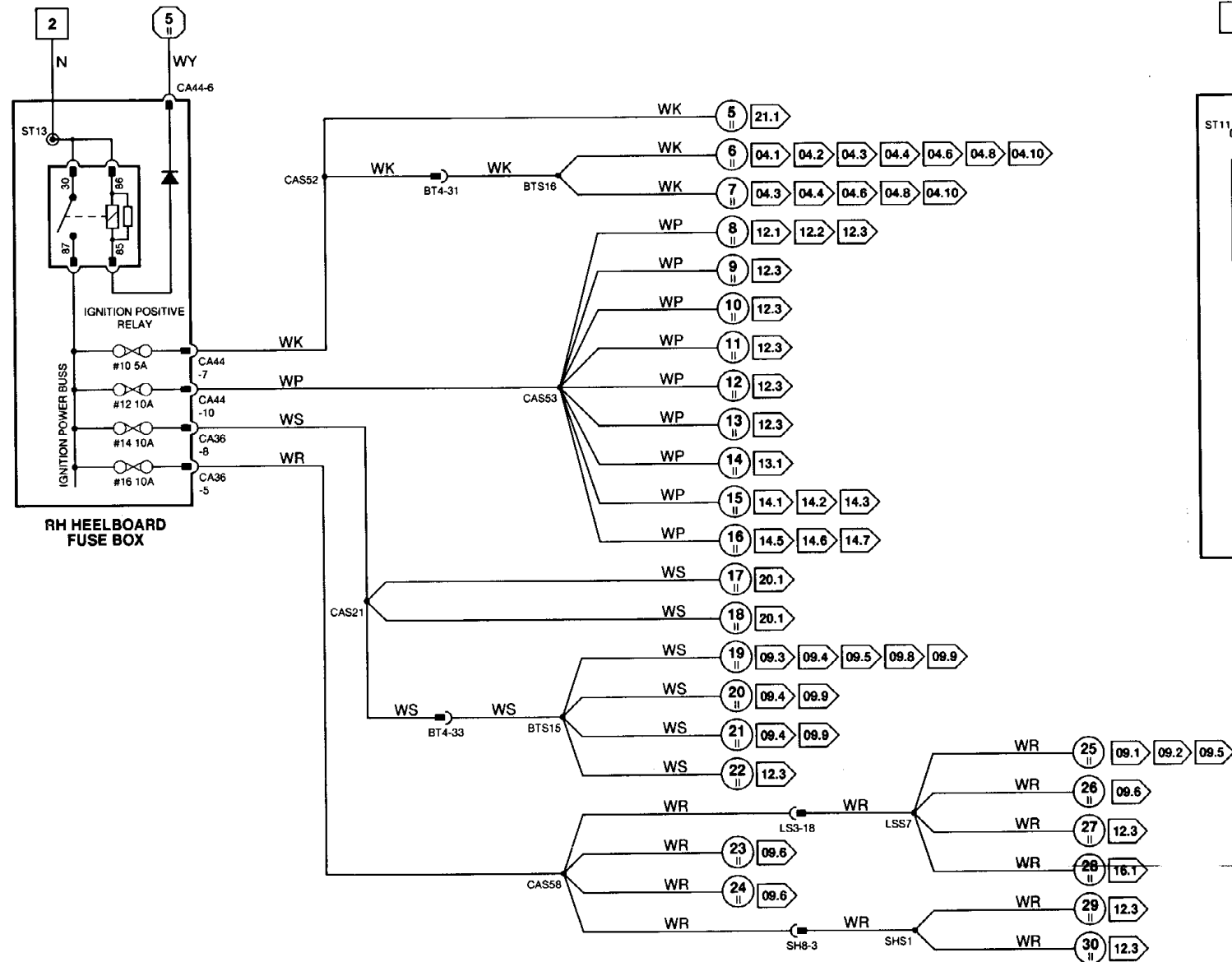
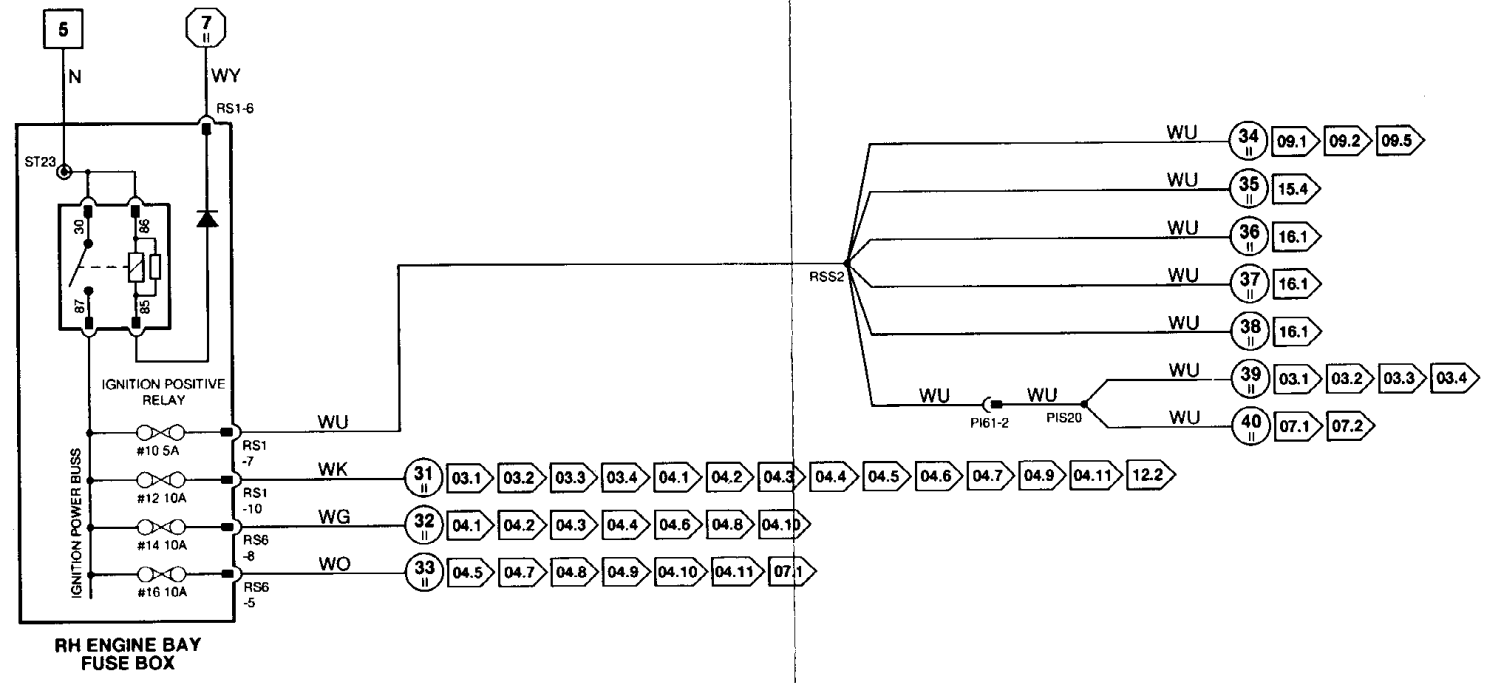
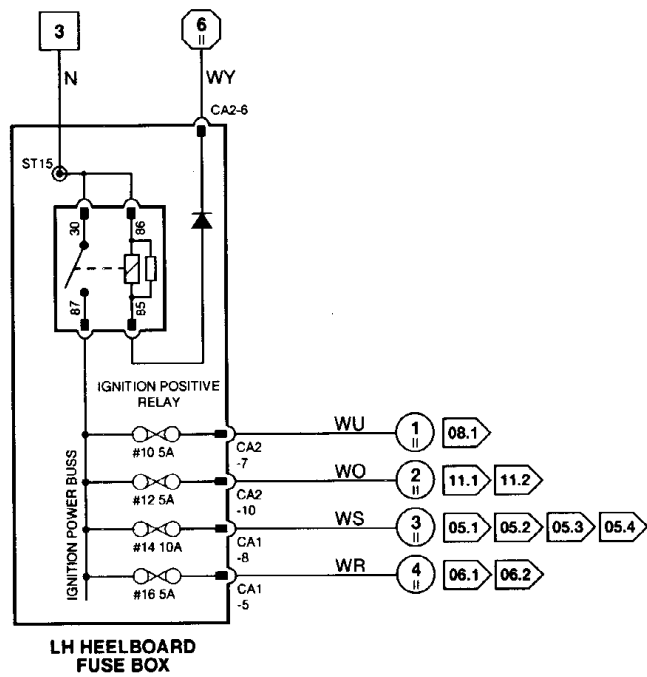
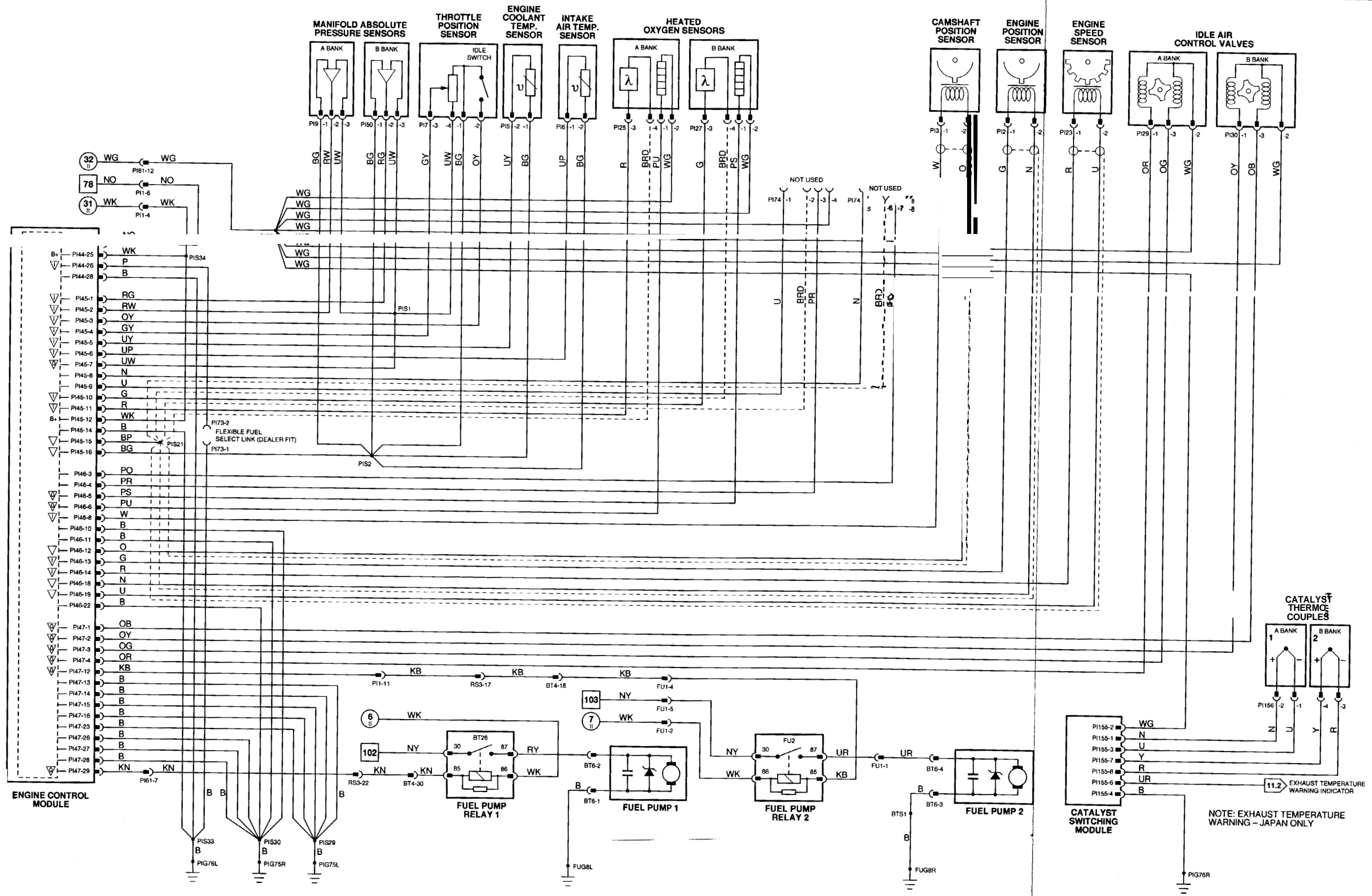

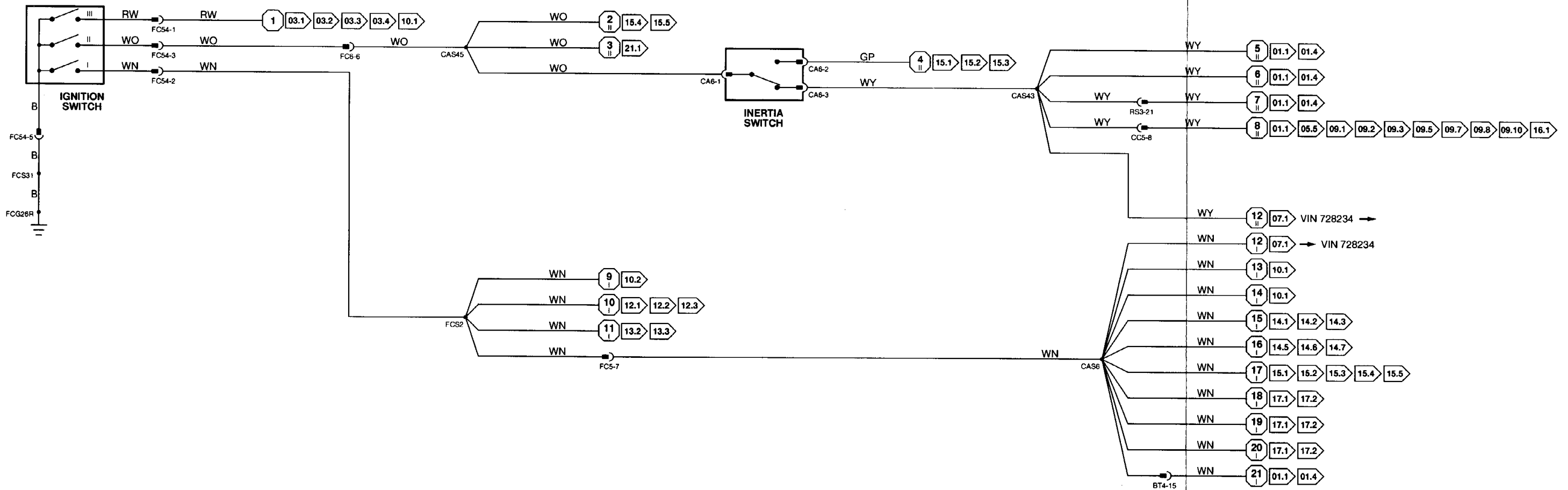
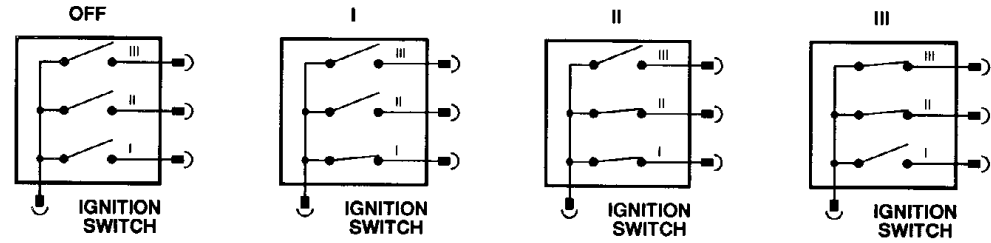

**Fig. 02.1****COMPONENTS****Component**IGNITION SWITCH  
INERTIA SWITCH**Connector / Type / Color**FC54 (FLY LEAD) / 8 WAY MULTILOCK 070 ■ WHITE  
CA6 ■ 3-WAY ECONOSEAL III LC / BLACK**Location / Access**STEERING COLUMN / COVER  
RH 'A' POST**HARNESS-TO-HARNESS CONNECTORS****Connector****Type / Color**BT4 THROUGH-PANEL 148MICRO / 01 / BLACK  
CC5 20 WAY MULTILOCK 040 / GREEN  
FC5 THROUGH-PANEL 148MICRO / 01 / BLACK  
FC6 THROUGH-PANEL 148MICRO / 01 / BLACK  
RS3 THROUGH-PANEL 148 MICRO / 01 / BROWN**Location / Access**PARCEL SHELF / FUEL TANK TRIM  
CENTER CONSOLE / CENTER CONSOLE GLOVE BOX  
LH FASCIA END PANEL / OUTER AIR VENT  
RH FASCIA END PANEL / OUTER AIR VENT  
RH 'A' POST / 'A' POST PANEL**GROUNDS****Ground****Location / Type**

FCG26R LH CONSOLE GROUND STUD

REFER TO THE FRONT OF THE BOOK FOR ILLUSTRATIONS DETAILING THE LOCATION AND IDENTIFICATION OF COMPONENTS, RELAYS, CONNECTORS, HARNESES, GROUNDS, VEHICLE CONTROL MODULES AND CONTROL MODULE PINS.





**Fig. 02.2**

**COMPONENTS**

<b>Component</b>	<b>Connector / Type / Color</b>	<b>Location / Access</b>
BATTERY	ST8, ST10	TRUNK

**HARNESSTO-HARNESCONNECTORS**

<b>Connector</b>	<b>Type / Color</b>	<b>Location / Access</b>
BT4	THROUGH-PANEL 148 MICRO / 6) BLACK	PARCEL SHELF / FUEL TANK TRIM
CA8	10-WAY MULTILOCK 040 / GREEN	DRIVER'S UNDERSCUTTLE
CA11	20-WAY MULTILOCK 040 / BLACK	PASSENGERS UNDERSCUTTLE / ECM
CC4	14-WAY MULTILOCK 070 WHITE	CENTER CONSOLE / CENTER CONSOLE GLOVE BOX
FC7	THROUGH PANEL 148 MICRO / 6) / BLACK	PASSENGERS UNDERSCUTTLE

**GROUNDS**

<b>Ground</b>	<b>Location / Type</b>
BTG17	LOGIC GROUND STUD

REFER TO THE FRONT OF THIS BOOK FOR ILLUSTRATIONS DETAILING THE LOCATION AND IDENTIFICATION OF COMPONENTS, RELAYS, CONNECTORS, HARNESSES, GROUNDS, AND VEHICLE CONTROL MODULE PINS.

DATE OF ISSUE JANUARY 1995

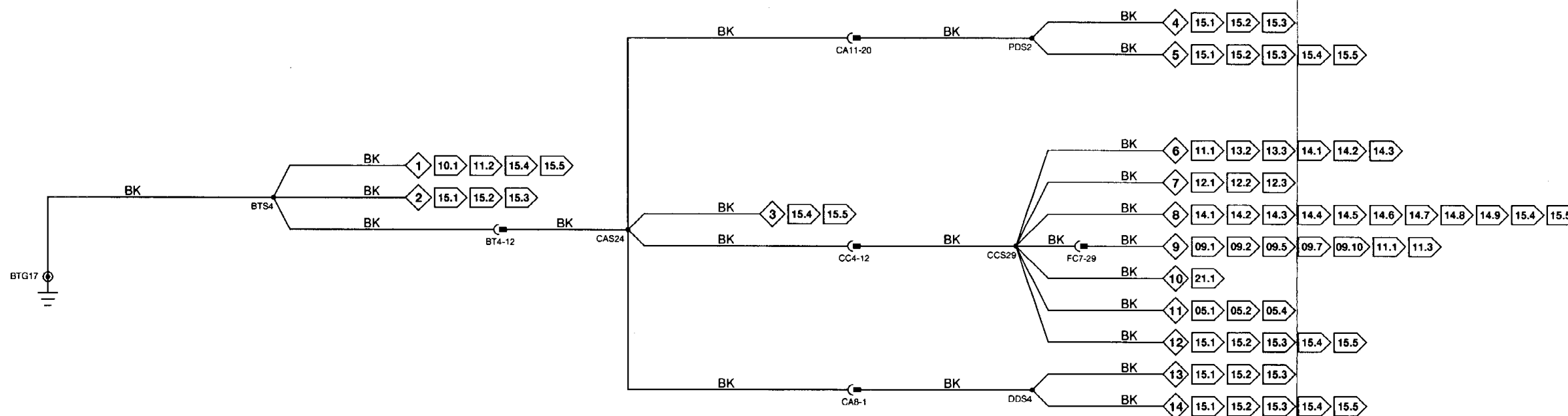

**CONTROL MODULE PIN OUT INFORMATION**

**ENGINE CONTROL MODULE (AJ16)**

Pin	Description	Active	Inactive
O P1104-20	CHECK ENGINE MIL	GROUND	B+
D P1105-35	FUELING INHIBIT SIGNAL	ENCODED COMMUNICATIONS	

**BODY PROCESSOR MODULE**

Pin	Description	Active	Inactive
O FC1-33	STARTER RELAY INHIBIT	GROUND	B+
D FC2-5	SECURE STATUS INPUT FROM SECURITY AND LOCKING CONTROL MODULE	ENCODED COMMUNICATIONS	
I FC2-7	CHECK ENGINE MIL	GROUND	B+
I FC2-20	PARK / NEUTRAL SIGNAL	GROUND	B+
I FC2-41	INTERIOR LAMP EXTINGUISH DURING CRANK	GROUND	B+

**SECURITY AND LOCKING CONTROL MODULE**

Pin	Description	Active	Inactive
D CA21-10	SECURE STATUS OUTPUT TO BODY PROCESSOR	ENCODED COMMUNICATIONS	
D CA21-20	FUELING INHIBIT SIGNAL OUTPUT (NOT NASJ)	ENCODED COMMUNICATIONS	

**COMPONENTS**

Component	Connector ■Type / Color	Location / Access
BATTERY	ST8, ST10	TRUNK
BODY PROCESSOR MODULE	FC1 / 48-WAY PCB SIGNAL / YELLOW FC2 / 48-WAY PCB SIGNAL / BLACK FC3 / 6-WAY PCB SIGNAL / BLACK	PASSENGER'S UNDERSCUTTLE
DECODER MODULE	CC13 / 26-WAY MODU 4 / BLUE	CENTER CONSOLE
ENGINE CONTROL MODULE (AJ16)	P1104 / 38-WAY ECONOSEAL III / BLACK P1105 / 36-WAY ECONOSEAL III ■RED	RH 'A' POST ■A' PDST TRIM
GENERATOR	P1141 / 3-WAY NIPPON DENSO / BLACK	ENGINE, LH SIDE (AJ16); RH SIDE (V12)
IGNITION SWITCH	FC54 (FLY LEAD) / 18-WAY MULTILOCK 0701 WHITE	STEERING COLUMN ■COVER
ROTARY SWITCH	GB1 (FLY LEAD) / 8-WAY MULTILOCK 070 / WHITE GB2 (FLY LEAD) / 112-WAY MULTILOCK 0401 BLACK	'J' GATE ■CENTER CONSOLE
SECURITY AND LOCKING CONTROL MODULE	CA18 / 112-WAY MULTILOCK 41 / SLATE CA19 / 22-WAY MULTILOCK 47 ■SLATE CA20 / 16-WAY MULTILOCK 47 / SLATE CA21 / 26-WAY MULTILOCK 41 ■SLATE	TRUNK, LH FRONT / TRUNK TRIM
STARTER MOTOR	ST1 / EYELET ■WHITE ST2 / EYELET ■WHITE	ENGINE, LH REAR (AJ16); ENGINE, RH REAR (V12)
SUPPRESSION MODULE	AN3 (FLY LEAD) / 2-WAY ECONOSEAL III LC ■RED	ENGINE BAY, LH FRONT

**RELAYS**

Relay	Color / Stripe	Connector / Color	Location / Access
STARTER RELAY	BLACK	LS47 / BLACK	LH ENGINE BAY RELAYS

**HARNESSTO-HARNESSCONNECTORS**

Connector	Type / Color	Location / Access
CC3	20-WAY MULTILOCK 040 / BLACK	CENTER CONSOLE1 CENTER CONSOLE GLOVE BOX
CC5	20-WAY MULTILOCK 040 / GREEN	CENTER CONSOLE1 CENTER CONSOLE GLOVE BOX
FC6	THROUGH-PANEL (48 MICRO / 6) / BLACK	RH FASCIA END PANEL / OUTER AIR VENT
FC7	THROUGH-PANEL (48 MICRO / 6) / BLACK	PASSENGERSUNDERSCUTTLE
LS3	THROUGH-PANEL (48 MICRO / 6) / BLACK	LH 'A' POST / 'A' POST PANEL
P11	13-WAY ECONOSEAL III LC / WHITE	RH AIR CLEANER
P161	13-WAY ECONOSEAL III LC ■BLACK	RH AIR CLEANER
P163	20-WAY MULTILOCK 040 / BLACK	RH 'A' POST / 'A' POST TRIM
P166	2-WAY ECONOSEAL III HC / BLACK	LH AIR CLEANER
P1142	2-WAY ECONOSEAL III HC / BLACK	LH 'A' POST / 'A' POST TRIM
RS3	THROUGH-PANEL (48 MICRO / 6) / BROWN	RH 'A' POST / 'A' POST PANEL

**GROUNDS**

Ground	Location ■Type
FCG15L	LH CONSOLE GROUND STUD
FCG26R	LH CONSOLE GROUND STUD
ST9	BATTERY GROUND STUD

**CONTROL MODULE PIN OUT INFORMATION (FOLD OUT PAGE)**



The following symbols are used to represent values for Control Module Pin Out data:

- I Input
- O output
- SG Signal Ground
- D Serial and encoded communications
- B+ Battery voltage
- V Voltage (DC)
- Hz Frequency
- KHz Frequency x 1000
- MS Milliseconds
- MV Millivolts

**CAUTION:** The information on this data page is furnished to aid the user in understanding circuit operation. THIS INFORMATION SHOULD BE USED FOR REFERENCE ONLY.

**NOTE:** The values listed are approximately those that can be expected at the control module connector pins with all circuit connections made and all components connected and fitted. "Active" means a load is applied or a switch is ON; "Inactive" means a load is not applied or a switch is OFF.

REFER TO THE FRONT OF THE BOOK FOR ILLUSTRATIONS DETAILING THE LOCATION AND IDENTIFICATION OF COMPONENTS, RELAYS, CONNECTORS, HARNESSES, GROUNDS, VEHICLE CONTROL MODULES AND CONTROL MODULE PINS.

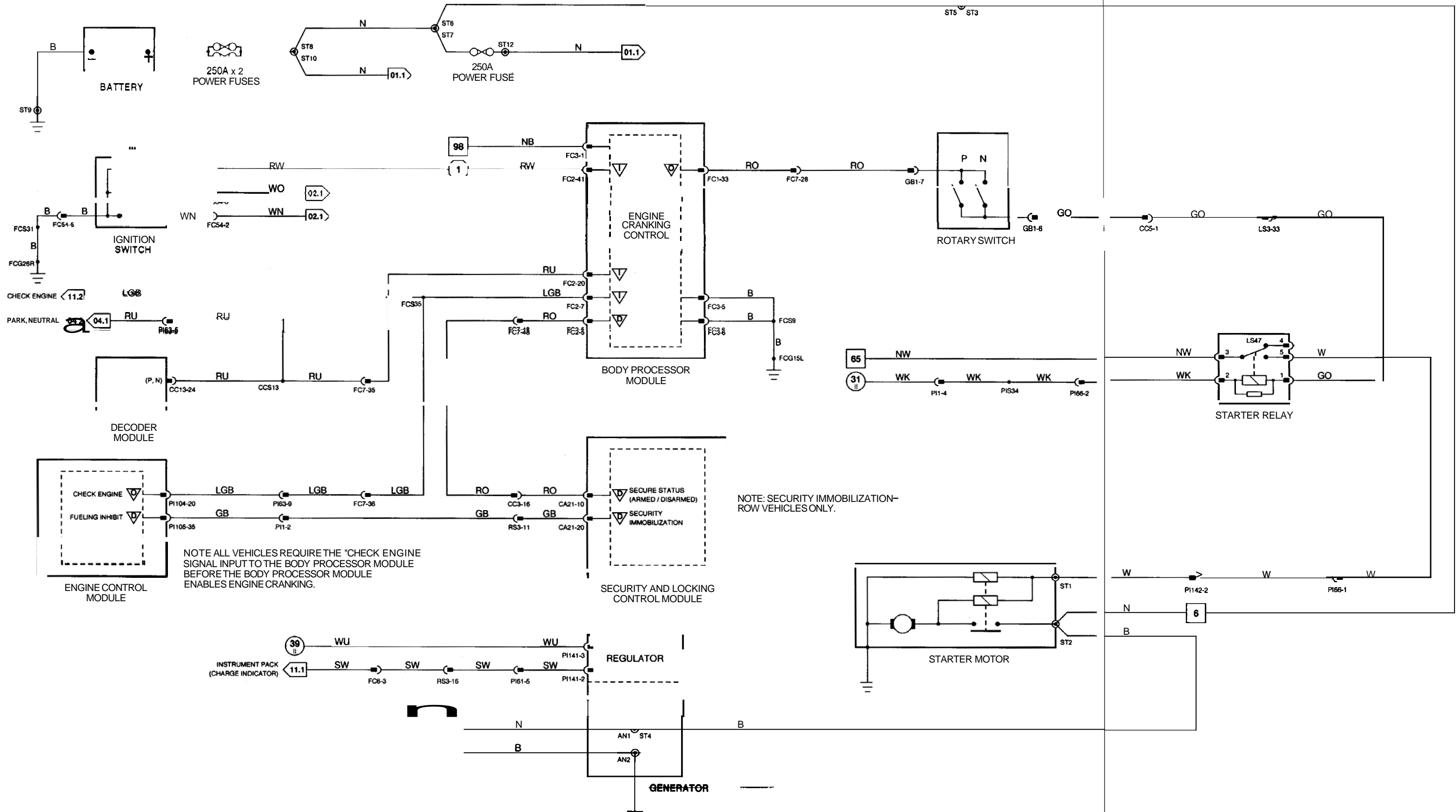

**Fig. 03.2**

**CONTROL MODULE PIN OUT INFORMATION**

**ENGINE CONTROL MODULE (AJ16)**

Pin	Description	Active	Inactive
O P1104-20	CHECK ENGINE MIL	GROUND	B+
D P1105-35	FUELING INHIBIT SIGNAL	ENCODED COMMUNICATIONS	

**BODY PROCESSOR MODULE**

Pin	Description	Active	Inactive
O FC1-33	STARTER RELAY INHIBIT	GROUND	B+
D FC2-5	SECURE STATUS INPUT FROM SECURITY AND LOCKING CONTROL MODULE	ENCODED COMMUNICATIONS	
I FC2-7	CHECK ENGINE MIL	GROUND	B+
I FC2-20	PARK / NEUTRAL SIGNAL	GROUND	B+
I FC2-41	INTERIOR LAMP EXTINGUISH DURING CRANK	GROUND	B+

**SECURITY AND LOCKING CONTROL MODULE**

Pin	Description	Active	Inactive
D CA21-10	SECURE STATUS OUTPUT TO BODY PROCESSOR	ENCODED COMMUNICATIONS	
O CA21-20	FUELING INHIBIT SIGNAL OUTPUT (NOT NAS)	ENCODED COMMUNICATIONS	

**COMPONENTS**

Component	Connector	Type	Color	Location / Access
BATTERY	ST8, ST10			TRUNK
BODY PROCESSOR MODULE	FC1 / 48-WAY PCB SIGNAL	YELLOW		PASSENGERS UNDERSCUTTLE
	FC2 / 48-WAY PCB SIGNAL	BLACK		
	FC3 / 6-WAY PCB SIGNAL	BLACK		
ENGINE CONTROL MODULE (AJ16)	P1104 / 36-WAY ECONOSEAL	III	BLACK	RH 'A' POST / 'A' POSTTRIM
	P1105 / 36-WAY ECONOSEAL	III	RED	
GENERATOR	P1141 / 3-WAY NIPPONDENSO		BLACK	ENGINE, LH SIDE (AJ16), RH SIDE (V12)
IGNITION SWITCH	FC54 (FLY LEAD)	1	8-WAY MULTILOCK 0701	WHITE
LINEAR GEAR POSITION SWITCHES	CC21 / 20-WAY MULTILOCK MO		BLACK	STEERING COLUMN COVER
SECURITY AND LOCKING CONTROL MODULE	CA18 / 112-WAY MULTILOCK 41		SLATE	'GATE / CENTER CONSOLE
	CA19 / 22-WAY MULTILOCK 47		SLATE	TRUNK, LH FRONT / TRUNK TRIM
	CA20 / 16-WAY MULTILOCK 47		SLATE	
	CA21 / 26-WAY MULTILOCK 47		SLATE	
STARTER MOTOR	ST1 / EYELET		WHITE	ENGINE, LH REAR (AJ16); ENGINE, RH REAR (V12)
	ST2 / EYELET		WHITE	
SUPPRESSION MODULE	AN3 (FLY LEAD)	12-WAY ECONOSEAL	III LC / RED	ENGINE BAY, LH FRONT

**RELAYS**

Relay	Color / Stripe	Connector / Color	Location / Access
STARTER RELAY	BLACK	LS47 BLACK	LH ENGINE BAY RELAYS

**HARNESSTO-HARNESCONNECTORS**

Connector	Type	Color	Location	Access
CC3	20-WAY MULTILOCK MO	BLACK	CENTER CONSOLE	CENTER CONSOLE GLOVE BOX
CC5	20-WAY MULTILOCK MO	GREEN	CENTER CONSOLE	CENTER CONSOLE GLOVE BOX
FC6	THROUGH-PANEL (48 MICRO / 6)	BLACK	RH FASCIA END PANEL	OUTER AIR VENT
FC7	THROUGH-PANEL (48 MICRO / 6)	BLACK	PASSENGERS UNDERSCUTTLE	
LS3	THROUGH-PANEL (48 MICRO / 6)	BLACK	LH 'A' POST / 'A' PDSTPANEL	
P11	13-WAY ECONOSEAL	III LC / WHITE	RH AIR CLEANER	
P161	13-WAY ECONOSEAL	III LC / BLACK	RH AIR CLEANER	
P163	20-WAY MULTILOCK 040	BLACK	RH 'A' POST / 'A' POSTTRIM	
P166	2-WAY ECONOSEAL	III HC / BLACK	LH AIR CLEANER	
P1142	2-WAY ECONOSEAL	III HC / BLACK	LH 'A' POST / 'A' POSTTRIM	
RS3	THROUGH-PANEL (48 MICRO / 6)	BROWN	RH 'A' POST / 'A' POSTPANEL	

**GROUNDS**

Ground	Location	Type
CCG51R	CENTER MNSOLE	GROUND STUD
FCG15L	LH CONSOLE	GROUND STUD
FCG26R	LH CONSOLE	GROUND STUD
ST9	BATTERY	GROUND STUD

**CONTROL MODULE PIN OUT INFORMATION (FOLD OUT PAGE)**



The following symbols are used to represent values for Control Module Pin Out data:

<b>I</b> Input	<b>B+</b> Battery voltage
<b>O</b> Output	<b>V</b> Voltage (DC)
<b>SG</b> Signal Ground	<b>Hz</b> Frequency
<b>D</b> Serial and encoded communications	<b>KHz</b> Frequency x 1000
	<b>MS</b> Milliseconds
	<b>MV</b> Millivolts

CAUTION: The information on this data page is furnished to aid the user in understanding circuit operation. THIS INFORMATION SHOULD BE USED FOR REFERENCE ONLY.

NOTE: The values listed are approximately those that can be expected at the control module connector pins with all circuit connections made and all components connected and fitted. "Active" means a load is applied or a switch is ON; "Inactive" means a load is not applied or a switch is OFF.

REFER TO THE FRONT OF THE BOOK FOR ILLUSTRATIONS DETAILING THE LOCATION AND IDENTIFICATION OF COMPONENTS, RELAYS, CONNECTORS, HARNESSES, GROUNDS, VEHICLE CONTROL MODULES AND CONTROL MODULE PINS.



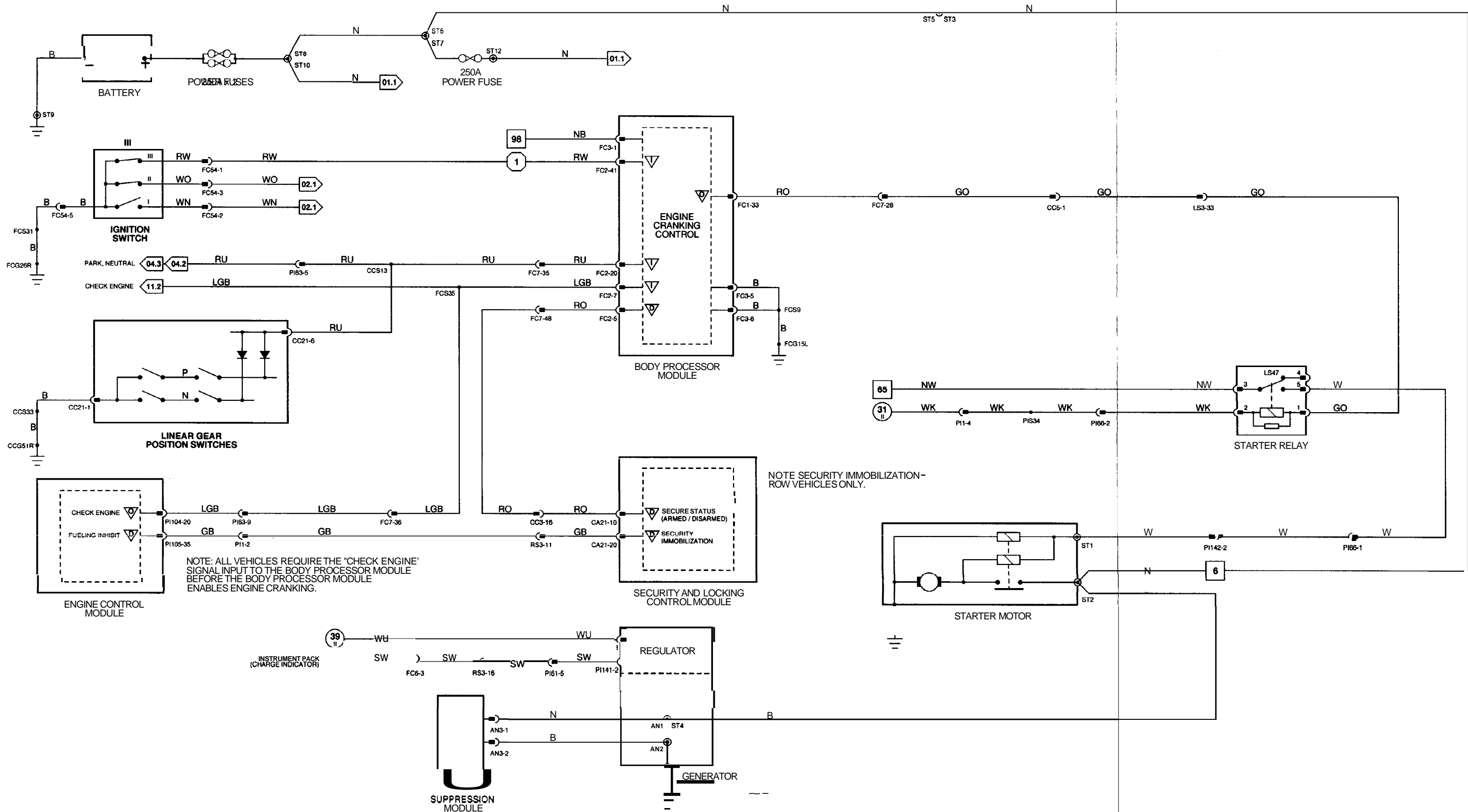

**Fig. 03.3**

CONTROL MODULE PIN OUT INFORMATION

ENGINE CONTROL MODULE (AJ16)

Pin	Description	Active	Inactive
O P1104-20	CHECK ENGINE MIL	GROUND	B+
O P1105-35	FUELING INHIBIT SIGNAL	ENCODED COMMUNICATIONS	

BODY PROCESSOR MODULE

Pin	Description	Active	Inactive
O FC1-33	STARTER RELAY INHIBIT	GROUND	B+
O FC25	SECURE STATUS INPUT FROM SECURITY AND LOCKING CONTROL MODULE	ENCODED COMMUNICATIONS	
I FC2-7	CHECK ENGINE MIL	GROUND	B+
I FC2-20	PARK / NEUTRAL SIGNAL	GROUND	B+
I FC2-41	INTERIOR LAMP EXTINGUISH DURING CRANK	GROUND	B+

SECURITY AND LOCKING CONTROL MODULE

Pin	Description	Active	Inactive
D CA21-10	SECURE STATUS OUTPUT TO BODY PROCESSOR	ENCODED COMMUNICATIONS	
D CA21-20	FUELING INHIBIT SIGNAL OUTPUT (NOT NAS)	ENCODED COMMUNICATIONS	

COMPONENTS

Component	Connector / Type / Color	Location / Access
BATTERY	ST8, ST10	TRUNK
BODY PROCESSOR MODULE	FC1 / 48-WAY PCB SIGNAL / YELLOW FC2 / 48-WAY PCB SIGNAL / BLACK FC3 / 16-WAY PCB SIGNAL / BLACK	PASSENGER'S UNDERSCUTTLE
ENGINE CONTROL MODULE (AJ16)	P1104 / 36-WAY ECONOSEAL III / BLACK P1105 / 36-WAY ECONOSEAL III / RED	RH 'A' POST / 'A' POSTTRIM
GENERATOR	P1141 13-WAY NIPPON DENSO / BLACK	ENGINE, LH SIDE (AJ16), RH SIDE (V12)
IGNITION SWITCH	FC54 (FLY LEAD) / 8-WAY MULTILOCK 070 / WHITE	STEERING COLUMN / COVER
SECURITY AND LOCKING CONTROL MODULE	CA18 / 12-WAY MULTILOCK 47 / SLATE CA19 / 22-WAY MULTILOCK 47 / SLATE CA20 / 16-WAY MULTILOCK 47 / SLATE CA21 / 26-WAY MULTILOCK 47 / SLATE	TRUNK, LH FRONT / TRUNK TRIM
STARTER MOTOR	ST1 / EYELET / WHITE ST2 / EYELET / WHITE	ENGINE, LH REAR (AJ16); ENGINE, RH REAR (V12)
SUPPRESSION MODULE	AN3 (FLY LEAD) / 2-WAY ECONOSEAL III LC / RED	ENGINE BAY, LH FRONT

RELAYS

Relay	Color / Stripe	Connector / Color	Location / Access
STARTER RELAY	BLACK	LS47 / BLACK	LH ENGINE BAY RELAYS

HARNESS-TO-HARNESS CONNECTORS

Connector	Type / Color	Location / Access
CC3	20-WAY MULTILOCK 040 / BLACK	CENTER CONSOLE / CENTER CONSOLE GLOVE BOX
CC5	20-WAY MULTILOCK 040 / GREEN	CENTER CONSOLE / CENTER CONSOLE GLOVE BOX
FC6	THROUGH-PANEL (48 MICRO / 6) / BLACK	RH FASCIA END PANEL / OUTER AIR VENT
FC7	THROUGH-PANEL (48 MICRO / 6) / BLACK	PASSENGER'S UNDERSCUTTLE
LS3	THROUGH-PANEL (48 MICRO / 6) / BLACK	LH 'A' POST / 'A' POSTPANEL
PI1	13-WAY ECONOSEAL III LC / WHITE	RH AIR CLEANER
PI61	13-WAY ECONOSEAL III LC / BLACK	RH AIR CLEANER
PI63	20-WAY MULTILOCK 040 / BLACK	RH 'A' POST / 'A' POSTTRIM
PI6a	2-WAY ECONOSEAL III HC / SLACK	LH AIR CLEANER
PI142	2-WAY ECONOSEAL III HC / BLACK	LH 'A' POST / 'A' POSTTRIM
RS3	THROUGH-PANEL (48 MICRO / 6) / BROWN	RH 'A' POST / 'A' POSTPANEL

GROUNDS

Ground	Location / Type
FCG15L	LH CONSOLE GROUND S N D
FCG26R	LH CONSOLE GROUND STUD
ST9	BATTERY GROUND STUD

CONTROL MODULE PIN OUT INFORMATION (FOLD OUT PAGE)



The following symbols are used to represent values for Control Module Pin Out data:

I	Input	B+	Battery voltage
O	Output	V	Voltage (DC)
SG	Signal Ground	Hz	Frequency
D	Serial and encoded communications	KHz	Frequency x 1000
		MS	Milliseconds
		MV	Millivolts

CAUTION: The information on this data page is furnished to aid the user in understanding circuit operation. THIS INFORMATION SHOULD BE USED FOR REFERENCE ONLY.

NOTE: The values listed are approximately those that can be expected at the control module connector pins with all circuit connections made and all components connected and fitted. "Active" means a load is applied or a switch is ON; "Inactive" means a load is not applied or a switch is OFF.

REFER TO THE FRONT OF THE BOOK FOR ILLUSTRATIONS DETAILING THE LOCATION AND IDENTIFICATION OF COMPONENTS, RELAYS, CONNECTORS, HARNESES, GROUNDS, VEHICLE CONTROL MODULES AND CONTROL MODULE PINS.

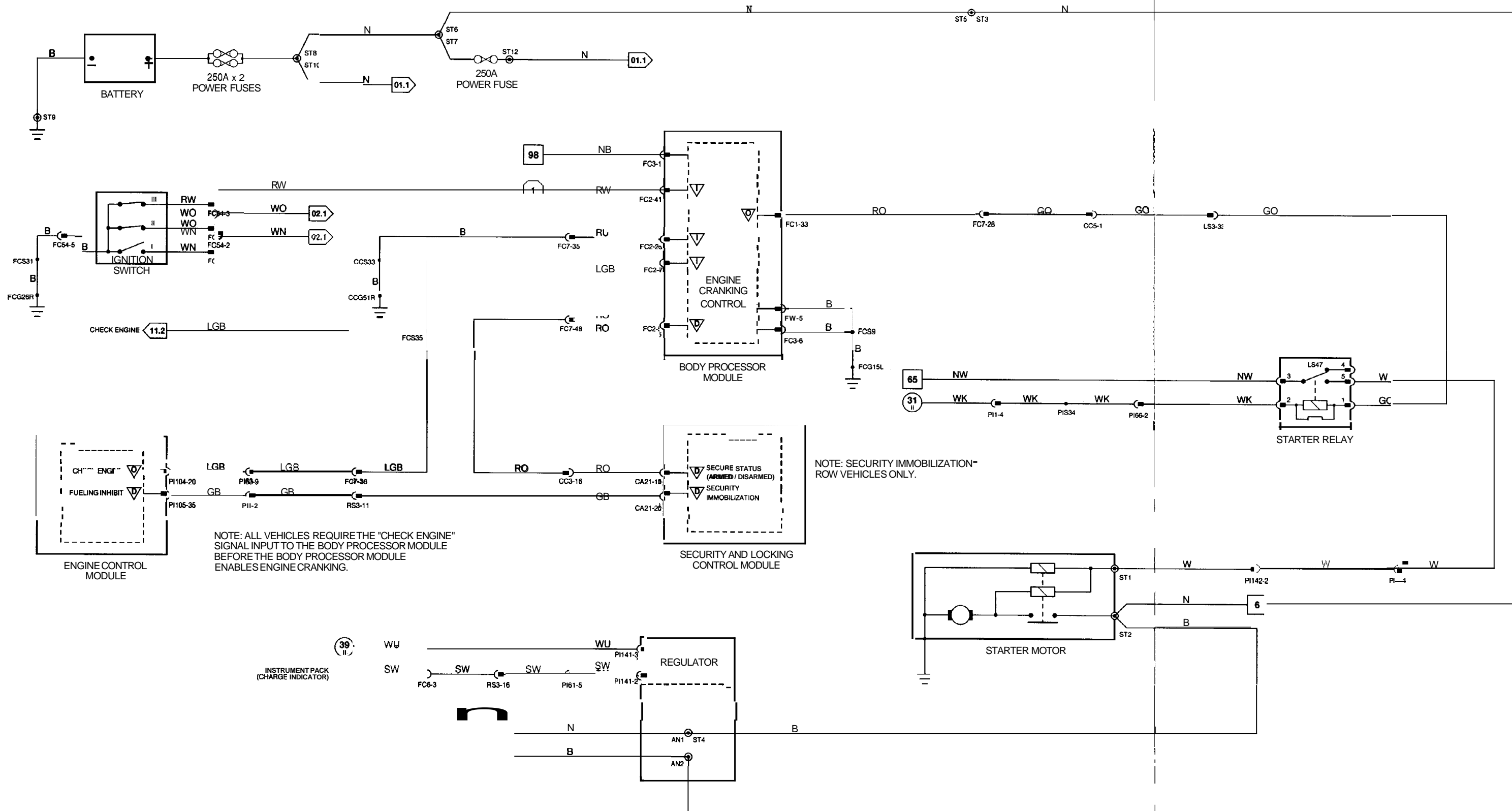

CONTROL MODULE PIN OUT INFORMATION

ENGINE CONTROL MODULE (V12)

Pin	Description	Active	Inactive
O P144-2	CHECK ENGINE MIL	GROUND	B+
D P144-14	START INHIBIT	GROUND	B+

BODY PROCESSOR MODULE

Pin	Description	Active	Inactive
O FC1-33	STARTER RELAY INHIBIT	GROUND	B+
D FCZ-5	SECURE STATUS INPUT FROM SECURITY AND LOCKING CONTRDL MODULE	ENCODED COMMUNICATIONS	B+
I FC2-7	CHECK ENGINE MIL	GROUND	B+
I FC2-20	PARK NEUTRAL SIGNAL	GROUND	B+
I FC2-41	INTERIOR LAMP EXTINGUISH DURING CRANK	GROUND	B+

SECURITY AND LOCKING CONTROL MODULE

Pin	Description	Active	Inactive
D CA21-10	SECURE STATUS OUTPUT TO BODY PROCESSOR	ENCODED COMMUNICATIONS	
D CA21-20	FUELING INHIBIT SIGNAL OUTPUT (NOT NAS)	ENCODED COMMUNICATIONS	

Fig. 03.4

COMPONENTS

Component	Connector ■Type ■Color	Location / Access
BATTERY	ST8, ST10	TRUNK
BODY PROCESSOR MODULE	FC1 / 48-WAY PCB SIGNAL1 YELLOW FC2 / 48-WAY PCB SIGNAL1 BLACK FC3 / 6-WAY PCB SIGNAL / BLACK	PASSENGERS UNDERSCUTTLE
ENGINE CONTROL MODULE (V12)	P144 / 28-WAY MULTILOCK 040 / SLATE P145 / 16-WAY MULTILOCK 040 / SLATE P146 / 22-WAY MULTILOCK 040 / SLATE P147 / 134-WAY MULTILOCK 040 / SLATE	RH 'A' POST / 'A' POSTTRIM
GENERATOR	P1141 / 3-WAY NIPPON DENS0 ■BLACK	ENGINE, LH SIDE (AJ16), RH SIDE (V12)
IGNITION SWITCH	FC54 (FLY LEAD) / 8-WAY MULTILOCK 070 / WHITE	STEERING COLUMN / COVER
LINEAR GEAR POSITION SWITCHES	CC21 120-WAY MULTILOCK 040 / BLACK	'J' GATE / CENTER CONSOLE
SECURITY AND LOCKING CONTROL MODULE	CA18 ■12-WAY MULTILOCK 41 ■SLATE CA19 / 22-WAY MULTILOCK 47 / SLATE CA201 16-WAY MULTILOCK 47 / SLATE CA21 / 28-WAY MULTILOCK 41 ■SLATE	TRUNK, LH FRONT / TRUNK TRIM
STARTER MOTOR	ST1 ■EYELET ■WHITE ST2 ■EYELET ■WHITE	ENGINE, LH REAR (AJ16); ENGINE, RH REAR (V12)
SUPPRESSION MODULE	AN3 (FLY LEAD) ■2-WAY ECONOSEAL ■11 LC / RED	ENGINE BAY, LH FRONT

RELAYS

Relay	Color / Stripe	Connector ■Color	Location ■Access
STARTER RELAY	BLACK	LS47 / BLACK	LH ENGINE BAY RELAYS

HARNESS-TO-HARNESS CONNECTORS

Connector	Type ■Color	Location ■Access
CC3	20-WAY MULTILOCK MO ■BLACK	CENTER CONSOLE ■CENTER CONSOLE GLOVE BOX
CC5	20-WAY MULTILOCK 040 ■GREEN	CENTER CONSOLE / CENTER CONSOLE GLOVE BOX
FC6	THROUGH-PANEL (48 MICRO / 8) ■BLACK	RH FASCIA END PANEL / OUTER AIR VENT
FC7	THROUGH-PANEL (48 MICRO / 8) / BLACK	PASSENGERS UNDERSCUTTLE
LS3	THROUGH-PANEL (48 MICRO / 8) / BLACK	LH 'A' POST / 'A' POST PANEL
P11	13-WAY ECONOSEAL ■11 LC ■WHITE	RH AIR CLEANER
PIE1	13-WAY ECONOSEAL ■11 LC ■BLACK	RH AIR CLEANER
PI63	20-WAY MULTILOCK 040 ■BLACK	RH 'A' POST / 'A' POSTTRIM
PI66	2-WAY ECONOSEAL ■11 HC ■BLACK	LH AIR CLEANER
PI142	2-WAY ECONOSEAL ■11 HC / BLACK	LH 'A' POST / 'A' POSTTRIM
RS3	THROUGH-PANEL (48 MICRO / 8) ■BROWN	RH 'A' POST / 'A' POST PANEL

GROUNDS

Ground	Location ■Type
CCG51R	CENTER CONSOLE GROUND STUD
FCG15L	LH CONSOLE GROUND STUD
FCG26R	LH CONSOLE GROUND STUD
STS	BATTERY GROUND STUD

CONTROL MODULE PIN OUT INFORMATION (FOLD OUT PAGE)



The following symbols are used to represent values for Control Module Pin Out data:

I Input	B+ Battery voltage
O Output	V Voltage (DC)
SG Signal Ground	Hz Frequency
D Serial and encoded communications	KHz Frequency x 1000
	MS Milliseconds
	MV Millivolts

CAUTION: The information on this data page is furnished to aid the user in understanding circuit operation. THIS INFORMATION SHOULD BE USED FOR REFERENCE ONLY.

NOTE: The values listed are approximately those that can be expected at the control module connector pins with all circuit connections made and all components connected and fitted. "Active" means a load is applied or a switch is ON; "Inactive" means a load is not applied or a switch is OFF.

REFER TO THE FRONT OF THE BOOK FOR ILLUSTRATIONS DETAILING THE LOCATION AND IDENTIFICATION OF COMPONENTS, RELAYS, CONNECTORS, HARNESES, GROUNDS, VEHICLE CONTROL MODULES AND CONTROL MODULE PINS.

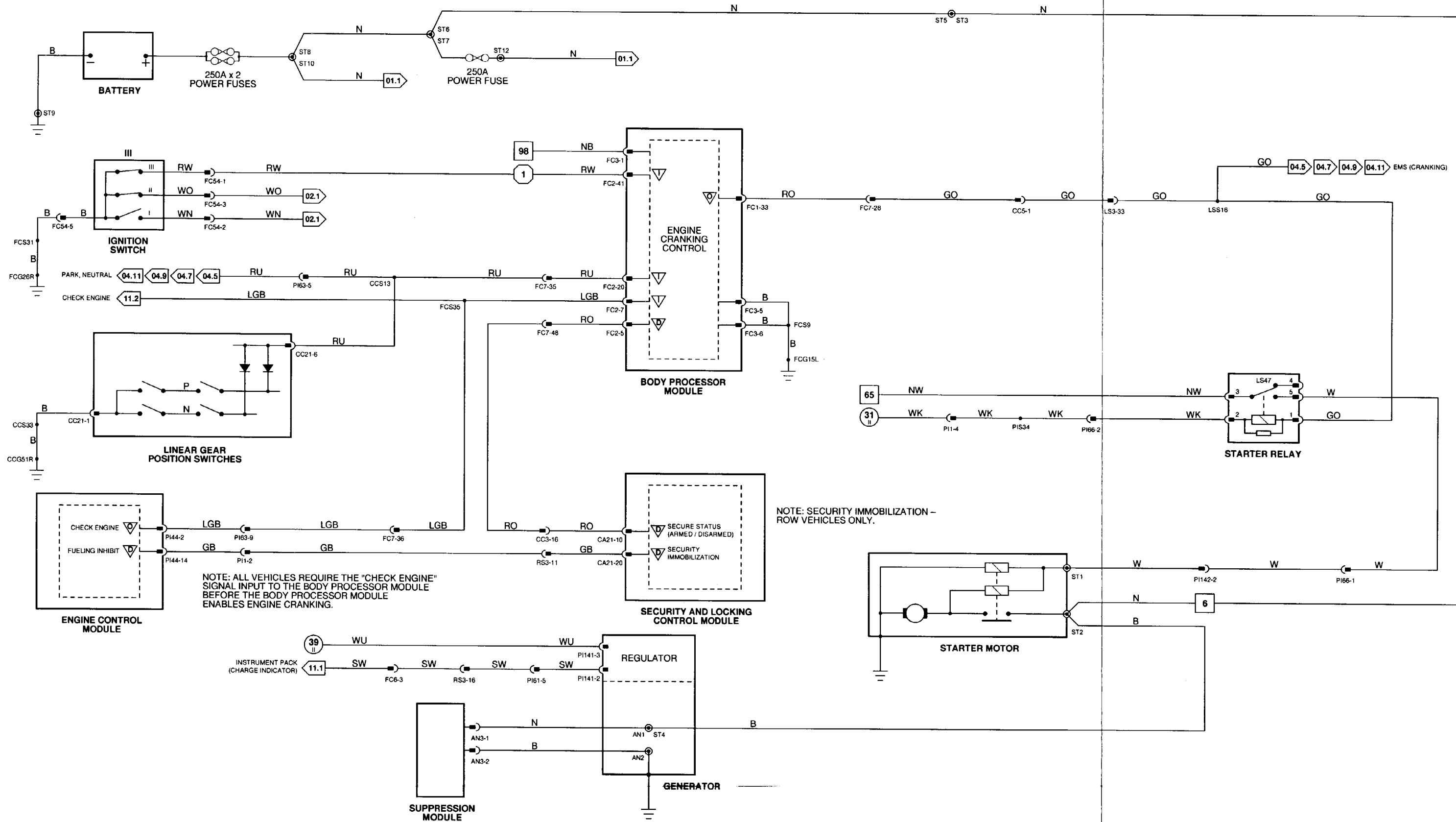

**CONTROL MODULE PIN OUT INFORMATION**

**ENGINE CONTROL MODULE (AJ16)**

Pin	Description	Active	Inactive
O P1104-2	INJECTOR 1	GROUND PULSE, 2.8 MS @ IDLE	B+
O P1104-3	IDLE SPEED CONTROL 1	12 V, 0 V	8 V (NOT MOVING)
O P1104-4	DOWNSTREAM HO2S HEATERS	0.4-13 V, 10 Hz @ IDLE	
O P1104-5	IGNITION COIL 4	GROUND PULSE, 1000 RPM = 15 Hz	
O P1104-6	IGNITION COIL 3	GROUND PULSE, 1000 RPM = 15 Hz	
O P1104-7	SECONDARY AIR INJECTION RELAY	GROUND	B+
O P1104-8	IGNITION COIL 2	GROUND PULSE, 1000 RPM = 15 Hz	
O P1104-9	IGNITION COIL 5	GROUND PULSE, 1000 RPM = 15 Hz	
O P1104-10	IGNITION COIL 1	GROUND PULSE, 1000 RPM = 15 Hz	
O P1104-11	IGNITION COIL 6	GROUND PULSE, 1000 RPM = 15 Hz	
O P1104-13	INJECTOR 4	GROUND PULSE, 2.8 MS @ IDLE	B+
O P1104-14	INJECTOR 3	GROUND PULSE, 2.8 MS @ IDLE	B+
O P1104-15	INJECTOR 2	GROUND PULSE, 2.6 MS @ IDLE	B+
O P1104-16	IDLE SPEED CONTROL 4	12 V, 0 V	6 V (NOT MOVING)
O P1104-17	FUEL USED	GROUND PULSE, 6 Hz @ IDLE	
O P1104-18	ECM CONTROLLED RELAY	GROUND	B+
O P1104-19	FUEL PUMP RELAY 1	GROUND	B+
O P1104-20	CHECK ENGINE MIL	GROUND	B+
O P1104-21	AIR CONDITIONING CLUTCH RELAY	GROUND	B+
O P1104-22	ENGINE SPEED SIGNAL	5 V @ 1000 RPM = 45 Hz, 2000 RPM = 90 Hz	
I P1104-23	CRANKSHAFT POSITION SENSOR	GROUND @ 1000 RPM = 900 Hz, 2000 RPM = 1800 Hz	
O P1104-25	INJECTOR 6	GROUND PULSE, 2.8 MS @ IDLE	B+
SG P1104-26	CRANKSHAFT POSITION SENSOR GROUND	GROUND	GROUND
O P1104-27	INJECTOR 5	GROUND PULSE, 2.9 MS @ IDLE	B+
O P1104-28	IDLE SPEED CONTROL 3	12 V, 0 V	8 V (NOT MOVING)
O P1104-29	IDLE SPEED CONTROL 2	12 V, 0 V	8 V (NOT MOVING)
O P1104-30	UPSTREAM HO2S HEATERS	0.4-13 V, 10 Hz @ IDLE	
O P1104-32	THROTTLE POSITION	1.25 V @ IDLE	4.9 V @ FULL THROTTLE
O P1104-33	ENGINE TORQUE	10.4 V (NO LOAD), DECREASING WITH LOAD INCREASE	
O P1104-34	EVAPORATIVE EMISSION CONTROL VALVE	B+	GROUND
O P1104-35	EGR VALVE SOLENOID	0.1 - 9 V	
I P1105-1	INTAKE AIR TEMPERATURE SENSOR	0.98 V @ 10° C, INCREASING WITH TEMPERATURE	
I P1105-2	ELECTRICAL LOAD HEATED WINDSHIELD, HEATED BACKLIGHT, OR BLOWERS ON HIGH SPEED	B+	GROUND
I P1105-3	EGR TEMPERATURE SENSOR	4.9 V @ IDLE (NO EGR), DECREASES WITH EGR FLOW INCREASE	
I P1105-4	MASS AIR FLOW SENSOR	1.2 V @ IDLE, INCREASES WITH RPM INCREASE	
I P1105-6	UPSTREAM HO2S FEEDBACK - CYLINDERS 1, 2, 3	0.1 - 4.7 V @ IDLE (SWING)	GROUND
SG P1105-7	SENSOR COMMON REFERENCE GROUND	GROUND	GROUND
SG P1105-8	HO2S COMMON SIGNAL GROUND	GROUND	GROUND
SG P1105-9	KNOCK SENSORS COMMON REFERENCE GROUND	GROUND	GROUND
D P1105-10	SERIAL COMMUNICATION (BI-DIRECTIONAL)		
O P1105-11	SENSOR COMMON REFERENCE VOLTAGE	5 v	5 v
P1105-12	THROTTLE POSITION SENSOR FEEDBACK	0.6V @ IDLE	4.9 V = FULL THROTTLE
I P1105-14	ENGINE COOLANT TEMPERATURE SENSOR	0.41 V @ 90° C, INCREASING WITH TEMPERATURE INCREASE	
P1105-15	EGR VALVE POSITION FEEDBACK	0.7 V @ IDLE (NO EGR)	5 V = MAXIMUM EGR
I P1105-16	DOWNSTREAM HO2S FEEDBACK - CYLINDERS 1, 2, 3	0.1 - 4.7 V @ IDLE (SWING)	
P1105-18	DOWNSTREAM HO2S FEEDBACK - CYLINDERS 4, 5, 6	0.1 - 4.7 V @ IDLE (SWING)	
P1105-19	UPSTREAM HO2S FEEDBACK - CYLINDERS 4, 5, 6	0.1 - 4.7 V @ IDLE (SWING)	
I P1105-20	LOW FUEL LEVEL	GROUND	B+
P1105-21	KNOCK SENSOR - A BANK	0 Hz = NO KNOCK, 2 - 20 Hz = KNOCK	
O P1105-24	CAMSHAFT POSITION SENSOR SUPPLY	B+	B+
P1105-26	TORQUE REDUCTION REQUEST	GROUND PULSE @ SHIFT	9.4 V @ IDLE
I P1105-27	PARK / NEUTRAL	GROUND	B+
I P1105-28	VEHICLE SPEED	GROUND PULSE @ 10 MPH 116 KPH = 20 Hz, 20 MPH 132 KPH = 40 Hz	
SG P1105-29	MASS AIR FLOW SENSOR GROUND	GROUND	GROUND
SG P1105-30	SENSOR COMMON SIGNAL GROUND	GROUND	GROUND
SG P1105-31	ENGINE COOLANT TEMPERATURE SENSOR GROUND	GROUND	GROUND
P1105-32	KNOCK SENSOR - B BANK	0 Hz = NO KNOCK, 2 - 20 Hz = KNOCK	
I P1105-34	CAMSHAFT POSITION SENSOR SIGNAL	1000 RPM = 45 Hz, 2000 RPM = 90 Hz	
D P1105-35	FUELING INHIBIT SIGNAL	ENCODED COMMUNICATIONS	
I P1105-36	AIR CONDITIONING REQUEST	GROUND	B+

The following symbols are used to represent values for Control Module Pin Out data:

<b>I</b> Input	<b>B+</b> Battery voltage
<b>O</b> Output	<b>V</b> Voltage (DC)
<b>SG</b> Signal Ground	<b>Hz</b> Frequency
<b>D</b> Serial and encoded communications	<b>KHz</b> Frequency x 1000
	<b>MS</b> Milliseconds
	<b>MV</b> Millivolts

**CAUTION:** The information on this data page is furnished to aid the user in understanding circuit operation. THIS INFORMATION SHOULD BE USED FOR REFERENCE ONLY.

**NOTE:** The values listed are approximately those that can be expected at the control module connector pins with all circuit connections made and all components connected and fitted. "Active" means a load is applied or a switch is ON; "Inactive" means a load is not applied or a switch is OFF.

**COMPONENTS**

Component	Connector / Type / Color	Location / Access
CAMSHAFT POSITION SENSOR (AJ16)	P1112 / 3-WAY JUNIOR TIMER / BLACK	ENGINE RH SIDE
CRANKSHAFT POSITION SENSOR	P1111 (FLY LEAD) / 12-WAY ECONOSEAL III LC / BLACK	ENGINE TIMING COVER
DIODE (P181) - AIRP SOLENOID SUPPRESSION	P181 / DIODE / BLACK	EMS HARNESS SECONDARY AIR INJECTION PUMP
EGR TEMPERATURE SENSOR	P1110 (FLY LEAD) / 2-WAY ECONOSEAL III LC / BLACK	INTAKE MANIFOLD
EGR VALVE	P1117 / 5-WAY PACKARD / BLACK	INTAKE MANIFOLD
ENGINE CONTROL MODULE (AJ16)	P1104 / 36-WAY ECONOSEAL III / BLACK	RH 'A' POST / 'A' POST TRIM
	P1105 / 36-WAY ECONOSEAL III / RED	
	P1107 / 2-WAY JUNIOR TIMER / BLACK	ENGINE THERMOSTAT HOUSING
ENGINE COOLANT TEMPERATURE SENSOR (AJ16)	P1130 / 2-WAY JUNIOR TIMER / BLACK	BELOW LH FRONT RELAYS
EVAPORATIVE EMISSION CONTROL VALVE (AJ16)	P1120 / 2-WAY JUNIOR TIMER / SLATE	FUEL RAIL, INTAKE MANIFOLD
FUEL INJECTOR (AJ16 11)	P1121 / 2-WAY JUNIOR TIMER / SLATE	FUEL RAIL, INTAKE MANIFOLD
FUEL INJECTOR (AJ16 2)	P1122 / 2-WAY JUNIOR TIMER / SLATE	FUEL RAIL, INTAKE MANIFOLD
FUEL INJECTOR (AJ16 3)	P1123 / 2-WAY JUNIOR TIMER / SLATE	FUEL RAIL, INTAKE MANIFOLD
FUEL INJECTOR (AJ16 4)	P1124 / 2-WAY JUNIOR TIMER / SLATE	FUEL RAIL, INTAKE MANIFOLD
FUEL INJECTOR (AJ16 5)	P1125 / 2-WAY JUNIOR TIMER / SLATE	FUEL RAIL, INTAKE MANIFOLD
FUEL INJECTOR (AJ16 6)	P1126 (FLY LEAD) / 4-WAY ECONOSEAL III LC / BLACK	FUEL TANK / FUEL TANK TRIM
FUEL PUMP (1)	BT6 (FLY LEAD) / 4-WAY SUMITOMO 901 / WHITE	EXHAUST, DOWNSTREAM OF PRIMARY CATALYST
HEATED OXYGEN SENSOR (AJ16 - 12.3 DOWNSTREAM)	P1127 (FLY LEAD) / 4-WAY ECONOSEAL III LC / BLACK	EXHAUST, DOWNSTREAM OF PRIMARY CATALYST
HEATED OXYGEN SENSOR (AJ16 - 45.6 DOWNSTREAM)	P1128 (FLY LEAD) / 4-WAY ECONOSEAL III LC / BLACK	EXHAUST, UPSTREAM OF PRIMARY CATALYST
HEATED OXYGEN SENSOR (AJ16 - 12.3 UPSTREAM)	P1129 (FLY LEAD) / 4-WAY ECONOSEAL III LC / BLACK	EXHAUST, UPSTREAM OF PRIMARY CATALYST
HEATED OXYGEN SENSOR (AJ16 - 45.6 UPSTREAM)	P1113 / 4-WAY PACKARD / BLACK	THROTTLE BODY
IDLE AIR CONTROL VALVE (AJ16)	P1131 / 2-WAY SUMITOMO 90 / BROWN	CAMSHAFT COVER
IGNITION COIL (AJ16 1)	P1132 / 2-WAY SUMITOMO 90 / BROWN	CAMSHAFT COVER
IGNITION COIL (AJ16 2)	P1133 / 2-WAY SUMITOMO 90 / BROWN	CAMSHAFT COVER
IGNITION COIL (AJ16 3)	P1134 / 2-WAY SUMITOMO 90 / BROWN	CAMSHAFT COVER
IGNITION COIL (AJ16 4)	P1135 / 2-WAY SUMITOMO 90 / BROWN	CAMSHAFT COVER
IGNITION COIL (AJ16 5)	P1136 / 2-WAY SUMITOMO 90 / BROWN	CAMSHAFT COVER
IGNITION COIL (AJ16 6)	P1106 / 2-WAY JUNIOR TIMER / BLACK	ENGINE AIR INTAKE ELBOW
INTAKE AIR TEMPERATURE SENSOR (AJ16)	P1108 / 2-WAY JUNIOR TIMER / BLACK	ENGINE BLOCK, LH FRONT
KNOCK SENSOR (A)	P1109 / 2-WAY JUNIOR TIMER / BLACK	ENGINE BLOCK, LH REAR
KNOCK SENSOR (B)	P1116 / 13-WAY JUNIOR TIMER / BLACK	ENGINE AIR INTAKE
MASS AIR FLOW SENSOR	P1115 / 3-WAY PACKARD / BLACK	ENGINE, LH FRONT
SECONDARY AIR INJECTION PUMP	P1118 / 3-WAY JUNIOR TIMER / BLACK	THROTTLE BODY
THROTTLE POSITION SENSOR (AJ16)		

**RELAYS**

Relay	Color / Stripe	Connector / Color	Location / Access
ECM CONTROLLED RELAY (AJ16)	BLACK	P1119 / BLACK	RH ENGINE BAY RELAYS
FUEL PUMP RELAY (1)	BLACK / VIOLET	BT26 / GREEN	TRUNK ELECTRICAL CARRIER
SECONDARY AIR INJECTION RELAY (AJ16)	BLACK / WHITE	P1146 / BLACK	RH ENGINE BAY RELAYS

**HARNESS-TO-HARNESS CONNECTORS**

Connector	Type / Color	Location / Access
BT4	THROUGH-PANEL 48 MICRO / 6 / BLACK	PARCEL SHELF / FUEL TANK TRIM
P11	13-WAY ECONOSEAL III LC / WHITE	RH AIR CLEANER
P161	13-WAY ECONOSEAL III LC / BLACK	RH AIR CLEANER
P163	20-WAY MULTILOCK 040 / BLACK	RH 'A' POST / 'A' POST TRIM
RS3	THROUGH-PANEL 148 MICRO / 6 / BROWN	RH 'A' POST / 'A' POST PANEL

**GROUNDS**

Ground	Location / Type
CAG100	RH 'A' POST GROUND STUD
FUGBL	FRONT TRUNK GROUND STUD
PIG153L	RH BULKHEAD GROUND STUD
PIG153R	RH BULKHEAD GROUND STUD
PIG154R	LEFT FORWARD GROUND STUD

**CONTROL MODULE PIN OUT INFORMATION (FOLD OUT PAGE)**



REFER TO THE FRONT OF THE BOOK FOR ILLUSTRATIONS DETAILING THE LOCATION AND IDENTIFICATION OF COMPONENTS, RELAYS, CONNECTORS, HARNESSES, GROUNDS, VEHICLE CONTROL MODULES AND CONTROL MODULE PINS.

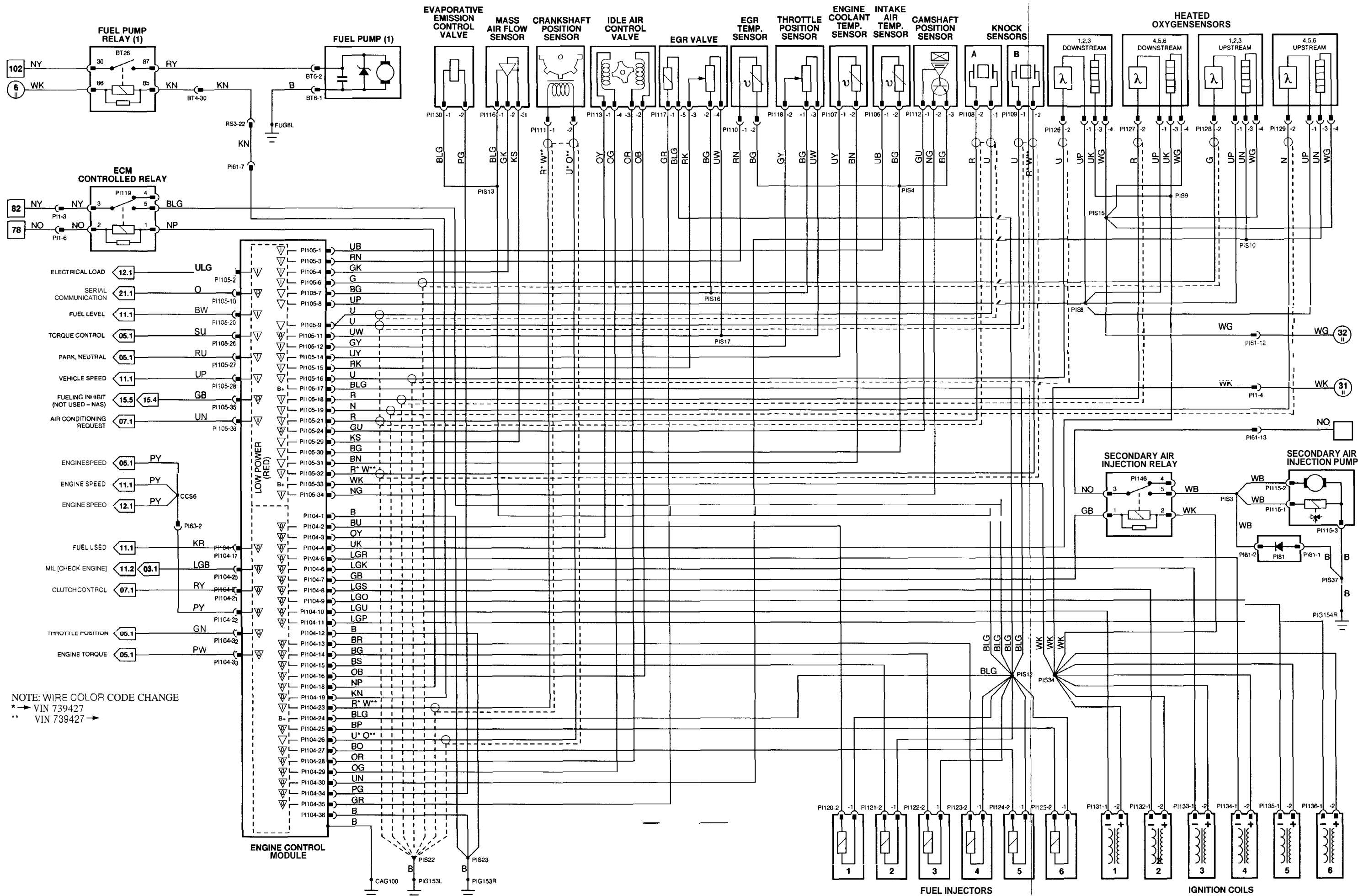

NOTE: WIRE COLOR CODE CHANGE  
 \* → VIN 739427  
 \*\* → VIN 739427 →

## CONTROL MODULE PIN OUT INFORMATION

### ENGINE CONTROL MODULE (AJ16)

Pin	Description	Active	Inactive
O P1104-2	INJECTOR 1	GROUND PULSE, 2.8 MS @ IDLE	B+
O P1104-3	IDLE SPEED CONTROL 1	12 V, 0 V	6 V (NOT MOVING)
O P1104-4	HO2S HEATERS	<b>0.4 - 13 V, 10 Hz @ IDLE</b>	
O P1104-5	IGNITION COIL 4	GROUND PULSE, 1000 RPM = 15 Hz	
O P1104-6	IGNITION COIL 3	GROUND PULSE, 1000 RPM = 15 Hz	
O P1104-7	SECONDARY AIR INJECTION RELAY	GROUND	B+
O P1104-8	IGNITION COIL 2	GROUND PULSE, 1000 RPM = 15 Hz	
O P1104-9	IGNITION COIL 5	GROUND PULSE, 1000 RPM = 15 Hz	
O P1104-10	IGNITION COIL 1	GROUND PULSE, 1000 RPM = 15 Hz	
O P1104-11	IGNITION COIL 6	GROUND PULSE, 1000 RPM = 15 Hz	
O P1104-13	INJECTOR 1	GROUND PULSE, 2.8 MS @ IDLE	B+
O P1104-14	INJECTOR 3	GROUND PULSE, 2.8 MS @ IDLE	B+
O P1104-15	INJECTOR 2	GROUND PULSE, 2.8 MS @ IDLE	B+
O P1104-16	IDLE SPEED CONTROL 4	12 V, 0 V	6 V (NOT MOVING)
O P1104-17	FUEL USED	GROUND PULSE, 6 Hz @ IDLE	
O P1104-18	ECM CONTROLLED RELAY	GROUND	B+
O P1104-19	FUEL PUMP RELAY 1	GROUND	B+
O P1104-20	CHECK ENGINE MIL	GROUND	B+
O P1104-21	AIR CONDITIONING CLUTCH RELAY	GROUND	B+
O P1104-22	ENGINE SPEED SIGNAL	5 V @ 1000 RPM = 45 Hz, 2000 RPM = 90 Hz	
I P1104-23	CRANKSHAFT POSITION SENSOR	GROUND @ 1000 RPM = 900 Hz, 2000 RPM = 1800 Hz	
O P1104-25	INJECTOR 6	GROUND PULSE, 2.8 MS @ IDLE	B+
SG P1104-26	CRANKSHAFT POSITION SENSOR GROUND	GROUND	GROUND
O P1104-27	INJECTOR 5	GROUND PULSE, 2.8 MS @ IDLE	B+
O P1104-28	IDLE SPEED CONTROL 3	12 V, 0 V	6 V (NOT MOVING)
O P1104-29	IDLE SPEED CONTROL 2	12 V, 0 V	8 V (NOT MOVING)
O P1104-32	THROTTLE POSITION	1.25 V @ IDLE	4.9 V @ FULL THROTTLE
O P1104-33	ENGINE TORQUE	10-1 V (NO LOAD), DECREASING WITH LOAD INCREASE	
O P1104-34	EVAPORATIVE EMISSION CONTROL VALVE	B+	GROUND
I P1105-1	INTAKE AIR TEMPERATURE SENSOR	0.98 V @ 10° C, INCREASING WITH TEMPERATURE	
I P1105-2	ELECTRICAL LOAD: HEATED WINDSHIELD, HEATED BACKLIGHT, OR BLOWERS ON HIGH SPEED	B+	GROUND
I P1105-4	MASS AIR FLOW SENSOR	1.2 V @ IDLE, INCREASES WITH RPM INCREASE	
SG P1105-7	SENSOR COMMON REFERENCE GROUND	GROUND	GROUND
SG P1105-8	HO2S COMMON SIGNAL GROUND	GROUND	GROUND
SG P1105-9	KNOCK SENSORS COMMON REFERENCE GROUND	GROUND	GROUND
O P1105-10	SERIAL COMMUNICATION 181-DIRECTIONAL)		
O P1105-11	SENSOR COMMON REFERENCE VOLTAGE	5 V	5 v
I P1105-12	THROTTLE POSITION SENSOR FEEDBACK	0.6 V @ IDLE	4.9 V = FULL THROTTLE
I P1105-14	ENGINE COOLANT TEMPERATURE SENSOR	0.41 V @ 90° C, INCREASING WITH TEMPERATURE INCREASE	
I P1105-16	HO2S FEEDBACK - CYLINDERS 1,2,3	0.1 - 4.7 V @ IDLE (SWING)	
I P1105-18	HO2S FEEDBACK - CYLINDERS 4,5,6	0.1 - 4.7 V @ IDLE (SWING)	
I P1105-20	LOW FUEL LEVEL	GROUND	B+
I P1105-21	KNOCK SENSOR - A BANK	0 Hz = NO KNOCK, 2-20 Hz = KNOCK	
O P1105-24	CAMSHAFT POSITION SENSOR SUPPLY	B+	B+
I P1105-26	TORQUE REDUCTION REQUEST	GROUND PULSE @ SHIFT	9.4 V @ IDLE
I P1105-27	PARK / NEUTRAL	GROUND	B+
I P1105-28	VEHICLE SPEED	GROUND PULSE @ 10 MPH (16 KPH) = 20 Hz, 20 MPH 132 KPH = 40 Hz	
SG P1105-29	MASS AIR FLOW SENSOR GROUND	GROUND	GROUND
SG P1105-30	SENSOR COMMON SIGNAL GROUND	GROUND	GROUND
SG P1105-31	ENGINE COOLANT TEMPERATURE SENSOR GROUND	GROUND	GROUND
I P1105-32	KNOCK SENSOR - B BANK	0 Hz = NO KNOCK, 2-20 Hz = KNOCK	
I P1105-34	CAMSHAFT POSITION SENSOR SIGNAL	1000 RPM = 45 Hz, 2000 RPM = 90 Hz	
D P1105-35	FUELING INHIBIT SIGNAL	ENCODED COMMUNICATIONS	
I P1105-36	AIR CONDITIONING REQUEST	GROUND	B+

The following symbols are used to represent values for Control Module Pin Out data:

<b>I</b> Input	<b>B+</b> Battery voltage
<b>O</b> output	<b>V</b> Voltage (DC)
<b>SG</b> Signal Ground	<b>Hz</b> Frequency
<b>D</b> Serial and encoded communications	<b>KHz</b> Frequency x 1000
	<b>MS</b> Milliseconds
	<b>MV</b> Millivolts

**CAUTION:** The information on this data page is furnished to aid the user in understanding circuit operation. THIS INFORMATION SHOULD BE USED FOR REFERENCE ONLY.

**NOTE:** The values listed are approximately those that can be expected at the control module connector pins with all circuit connections made and all components connected and fitted. "Active" means a load is applied or a switch is ON; "Inactive" means a load is not applied or a switch is OFF.

## Fig. 04.2

### COMPONENTS

Component	Connector / Type / Color	Location / Access
CAMSHAFT POSITION SENSOR (AJ16)	P1112 13-WAY JUNIOR TIMER / BLACK	ENGINE RH SIDE
CATALYST SWITCHING MODULE	P1155 8-WAY MULTILOCK 070 / WHITE	RH 'A' POST, ECM / 'A' POST TRIM
CATALYST THERMOCOUPLES	P1156 (FLY LEAD) / 4-WAY ECONOSEAL III LC / BLACK	REAR OF ENGINE
CRANKSHAFT POSITION SENSOR	P1111 (FLY LEAD) / 2-WAY ECONOSEAL III LC / BLACK	ENGINE TIMING COVER
DIODE (P181) - AIRP SOLENOID SUPPRESSION	P181 / DIODE / BLACK	EMS HARNESS / SECONDARY AIR INJECTION PUMP
ENGINE CONTROL MODULE IN161	P1104 / 36-WAY ECONOSEAL III / BLACK P1105 136-WAY ECONOSEAL III / RED	RH 'A' POST / 'A' POST TRIM
ENGINE COOLANT TEMPERATURE SENSOR (AJ16)	P1107 12-WAY JUNIOR TIMER / BLACK	ENGINE THERMOSTAT HOUSING
EVAPORATIVE EMISSION CONTROL VALVE (AJ16)	P1130 / 2-WAY JUNIOR TIMER / BLACK	BELOW LH FRONT RELAYS
FUEL INJECTOR (AJ16 1)	P1120 / 2-WAY JUNIOR TIMER / SLATE	FUEL RAIL, INTAKE MANIFOLD
FUEL INJECTOR (AJ16 2)	P1121 12-WAY JUNIOR TIMER / SLATE	FUEL RAIL, INTAKE MANIFOLD
FUEL INJECTOR (AJ16 3)	P1122 12-WAY JUNIOR TIMER / SLATE	FUEL RAIL, INTAKE MANIFOLD
FUEL INJECTOR (AJ16 4)	P1123 / 2-WAY JUNIOR TIMER / SLATE	FUEL RAIL, INTAKE MANIFOLD
FUEL INJECTOR (AJ16 5)	P1124 / 2-WAY JUNIOR TIMER / SLATE	FUEL RAIL, INTAKE MANIFOLD
FUEL INJECTOR IN16 6	P1125 / 2-WAY JUNIOR TIMER / SLATE	FUEL RAIL, INTAKE MANIFOLD
FUEL PUMP (1)	BT6 (FLY LEAD) 14-WAY SUMITOMO 90 / WHITE	FUEL TANK / FUEL TANK TRIM
HEATED OXYGEN SENSOR (AJ16 - 1,2,3)	P1126 (FLY LEAD) / 4-WAY ECONOSEAL III LC / BLACK	EXHAUST, DOWNSTREAM OF PRIMARY CATALYST
HEATED OXYGEN SENSOR (AJ16 - 4,5,6)	P1127 (FLY LEAD) 14-WAY ECONOSEAL III LC / BLACK	EXHAUST, DOWNSTREAM OF PRIMARY CATALYST
IDLE AIR CONTROL VALVE (AJ16)	P1113 14-WAY PACKARD / BLACK	THROTTLE BODY
IGNITION COIL (AJ16 1)	P1131 12-WAY SUMITOMO 90 / BROWN	CAMSHAFT COVER
IGNITION COIL (AJ16 2)	P1132 12-WAY SUMITOMO 90 / BROWN	CAMSHAFT COVER
IGNITION COIL (AJ16 3)	P1133 / 2-WAY SUMITOMO 90 / BROWN	CAMSHAFT COVER
IGNITION COIL (AJ16 4)	P1134 / 2-WAY SUMITOMO 90 / BROWN	CAMSHAFT COVER
IGNITION COIL (AJ16 5)	P1135 / 2-WAY SUMITOMO 90 / BROWN	CAMSHAFT COVER
IGNITION COIL (AJ16 6)	P1136 / 2-WAY SUMITOMO 90 / BROWN	CAMSHAFT COVER
INTAKE AIR TEMPERATURE SENSOR (AJ16)	P1106 / 2-WAY JUNIOR TIMER / BLACK	ENGINE AIR INTAKE ELBOW
KNOCK SENSOR (A)	P1108 12-WAY JUNIOR TIMER / BLACK	ENGINE BLOCK, LH FRONT
KNOCK SENSOR (B)	P1109 12-WAY JUNIOR TIMER / BLACK	ENGINE BLOCK, LH REAR
MASS AIR FLOW SENSOR	P1116 / 3-WAY JUNIOR TIMER / BLACK	ENGINE AIR INTAKE
SECONDARY AIR INJECTION PUMP	P1115 / 3-WAY PACKARD / BLACK	ENGINE, LH FRONT
THROTTLE POSITION SENSOR (AJ16)	P1118 / 3-WAY JUNIOR TIMER / BLACK	THROTTLE BODY

### RELAYS

Relay	Color / Stripe	Connector / Color	Location / Access
ECM CONTROLLED RELAY (AJ16)	BLACK	P1119 / BLACK	RH ENGINE BAY RELAYS
FUEL PUMP RELAY (1)	BLACK / VIOLET	BT26 / GREEN	TRUNK ELECTRICAL CARRIER
SECONDARY AIR INJECTION RELAY (AJ16)	BLACK / WHITE	P1146 / BLACK	RH ENGINE BAY RELAYS

### HARNESS-TO-HARNESS CONNECTORS

Connector	Type / Color	Location / Access
BT4	THROUGH-PANEL (48 MICRO / 6) / BLACK	PARCEL SHELF / FUEL TANK TRIM
P11	13-WAY ECONOSEAL III LC / WHITE	RH AIR CLEANER
P161	13-WAY ECONOSEAL III LC / BLACK	RH AIR CLEANER
P163	20-WAY MULTILOCK 040 / BLACK	RH 'A' POST / 'A' POST TRIM
RS3	THROUGH-PANEL (148 MICRO / 6) / BROWN	RH 'A' POST / 'A' POST PANEL

### GROUNDS

Ground	Location / Type
CAG100	RH 'A' POST GROUND STUD
FUG8L	FRONT TRUNK GROUND STUD
PIG153L	RH BULKHEAD GROUND STUD
PIG153R	RH BULKHEAD GROUND STUD
PIG154L	LEFT FORWARD GROUND STUD
PIG154R	LEFT FORWARD GROUND STUD

### CONTROL MODULE PIN OUT INFORMATION (FOLD OUT PAGE)



REFER TO THE FRONT OF THE BOOK FOR ILLUSTRATIONS DETAILING THE LOCATION AND IDENTIFICATION OF COMPONENTS, RELAYS, CONNECTORS, HARNESSES, GROUNDS, VEHICLE CONTROL MODULES AND CONTROL MODULE PINS.



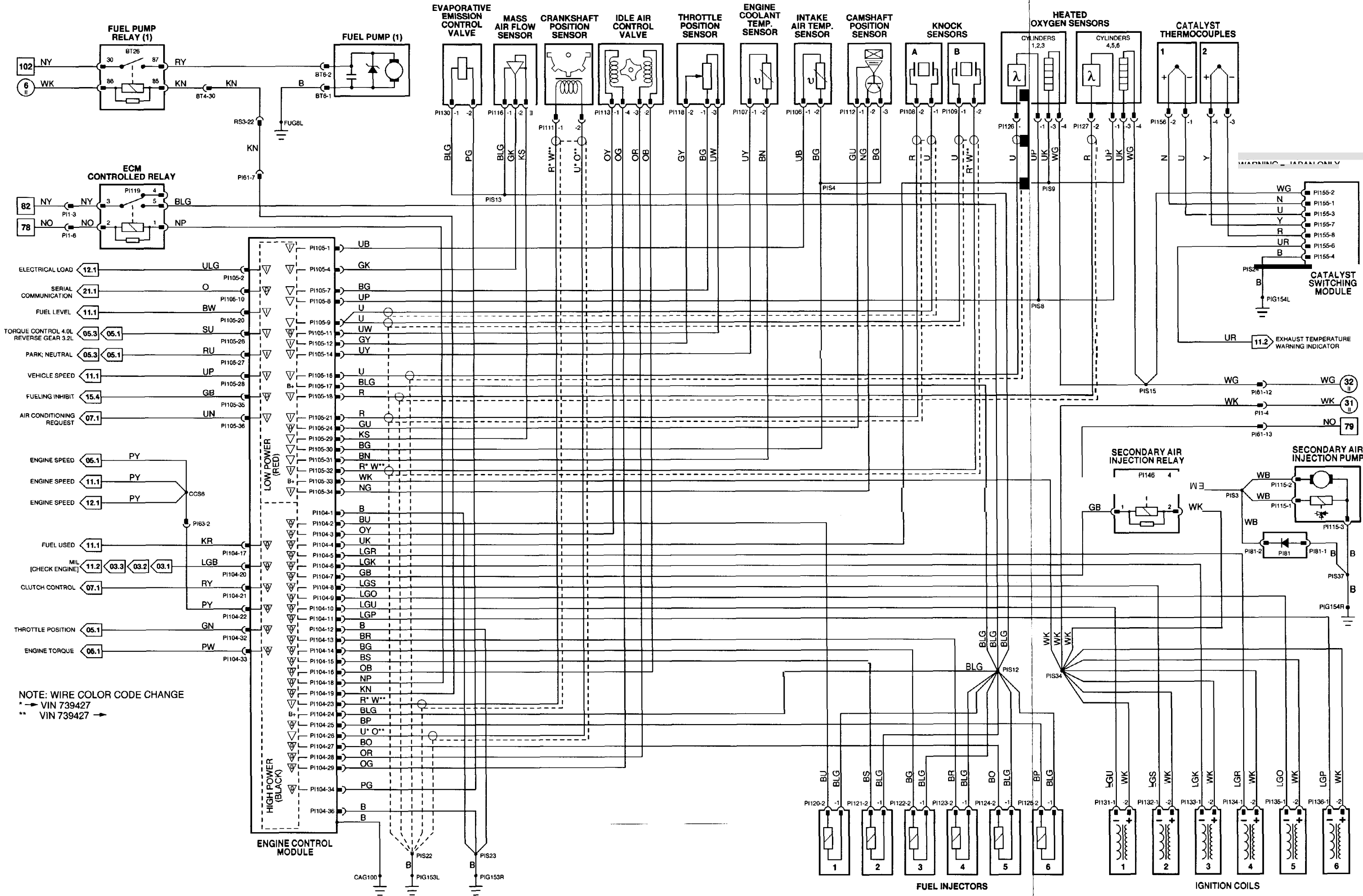

NOTE: WIRE COLOR CODE CHANGE  
 \* → VIN 739427  
 \*\* → VIN 739427 →



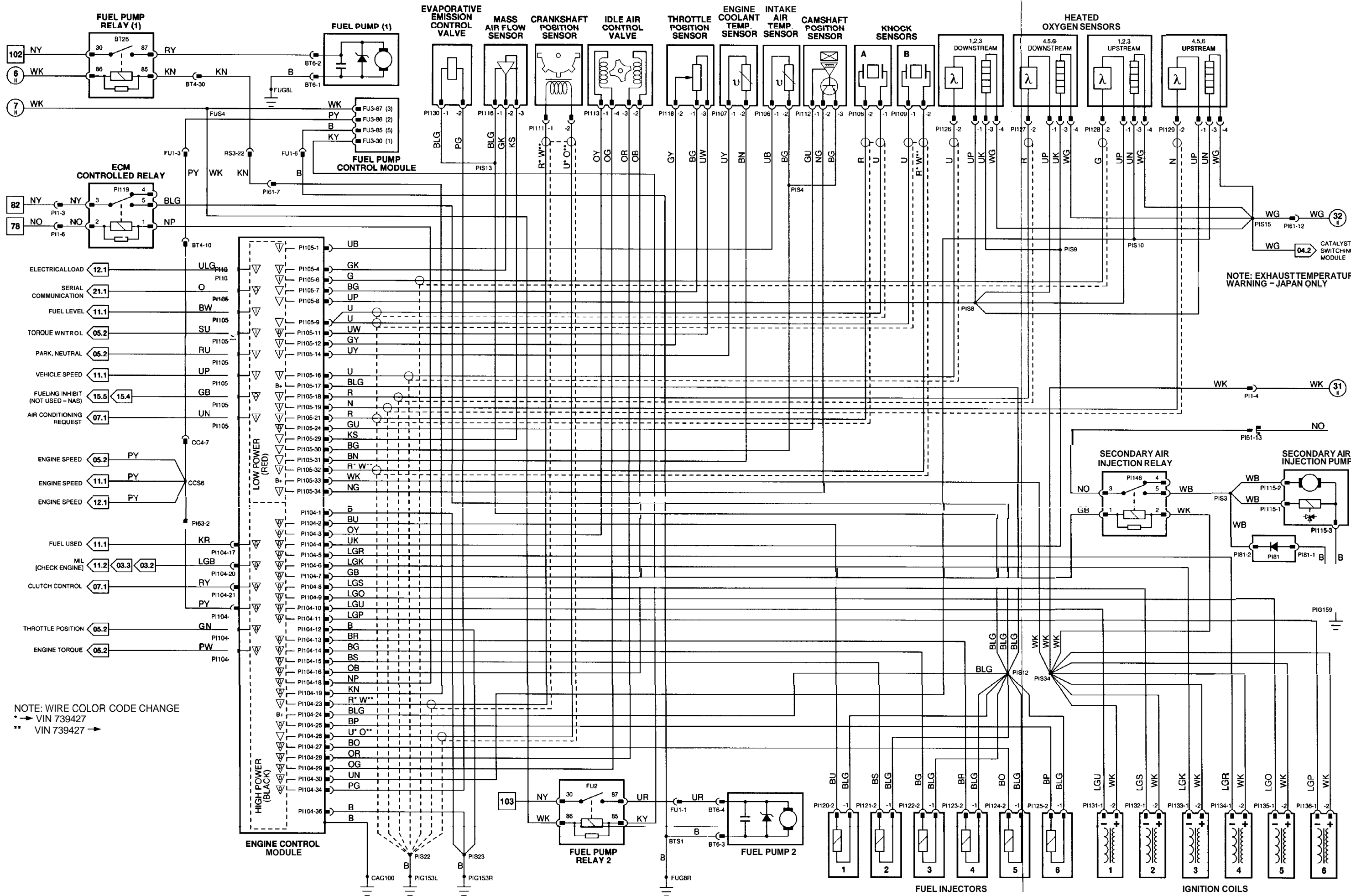

NOTE: EXHAUST TEMPERATURE WARNING - JAPAN ONLY

## CONTROL MODULE PIN OUT INFORMATION

### ENGINE CONTROL MODULE (V12)

Pin	Description	Active	Inactive
I P144-26	FLEXIBLE FUEL SELECT LINK (DEALER FIT)	GROUND (FITTED)	B+
I P145-1	MAP SENSOR FEEDBACK - B BANK	1.7 V @ IWE, INCREASING WITH MANIFOLD ABSOLUTE PRESSURE	
I P145-2	MAP SENSOR FEEDBACK - A BANK	1.7 V @ IWE, INCREASING WITH MANIFOLD ABSOLUTE PRESSURE	
I P145-3	IDLESWITCH	GROUND	B+
I P145-4	THROTTLE POSITION SENSOR FEEDBACK VOLTAGE	0.58 V @ IDLE, 4.75 V @ FULL THROTTLE	
I P145-5	COOLANT TEMPERATURE SENSOR	0.41 V @ 90° C, INCREASING WITH TEMPERATURE	
I P145-6	INTAKE AIR TEMPERATURE SENSOR	0.59 V @ 10° C, INCREASING WITH TEMPERATURE	
O P145-7	COMMON SENSOR REFERENCE VOLTAGE	5 v	5 v
I P145-8	DOWNSTREAM HO2S FEEDBACK - B BANK	0.1 - 0.8 V (SWING)	
I P145-9	DOWNSTREAM HO2S FEEDBACK - A BANK	0.1 - 0.8 V (SWING)	
I P145-10	UPSTREAM HO2S FEEDBACK - B BANK	0.1 - 0.8 V (SWING)	
I P145-11	UPSTREAM HO2S FEEDBACK - A BANK	0.1 - 0.8 V (SWING)	
SG P145-15	COMMON SENSOR SHIELD GROUND	GROUND	GROUND
SG P145-16	COMMON SENSOR REFERENCE GROUND	GROUND	GROUND
O P146-3	DOWNSTREAM HO2S HEATER GROUND - B BANK	GROUND	B+
O P146-4	DOWNSTREAM HO2S HEATER GROUND - A BANK	GROUND	B+
O P146-5	UPSTREAM HO2S HEATER GROUND - B BANK	GROUND	B+
O P146-6	UPSTREAM HO2S HEATER GROUND - A BANK	GROUND	B+
I P146-8	CAMSHAFT POSITION SENSOR	GROUND PULSE @ 1000 RPM = 8 Hz, 2000 RPM = 16 Hz	
SG P146-12	CAMSHAFT POSITION SENSOR	GROUND	GROUND
I P146-13	ENGINE POSITION SENSOR	GROUND PULSE @ 1000 RPM = 15 Hz, 2000 RPM = 30 Hz	
I P146-14	ENGINE SPEED SENSOR	GROUND PULSE @ 1000 RPM = 175 Hz, 2000 RPM = 350 Hz	
SG P146-18	ENGINE POSITION SENSOR	GROUND	GROUND
SG P146-19	ENGINE SPEED SENSOR	GROUND	
O P147-1	IDLE AIR CONTROL VALVE CLOSE - B BANK	4.6 V @ IDLE	
O P147-2	IDLE AIR CONTROL VALVE OPEN - B BANK	9.6 V @ IDLE	
O P147-3	IDLE AIR CONTROL VALVE CLOSE - A BANK	4.8 V @ IDLE	
O P147-4	IDLE AIR CONTROL VALVE OPEN - A BANK	9.8 V @ IDLE	
O P147-12	FUEL PUMP RELAY 2	GROUND	B+
O P147-29	FUEL PUMP RELAY 1	GROUND	B+

The following symbols are used to represent values for Control Module Pin Out data:

I	Input	B+	Battery voltage
O	Output	V	Voltage (DC)
SG	Signal Ground	Hz	Frequency
D	Serial and encoded communications	KHz	Frequency x 1000
		MS	Milliseconds
		MV	Millivolts

**CAUTION:** The information on this data page is furnished to aid the user in understanding circuit operation. THIS INFORMATION SHOULD BE USED FOR REFERENCE ONLY.

**NOTE:** The values listed are approximately those that can be expected at the control module connector pins with all circuit connections made and all components connected and fixed. "Active" means a load is applied or a switch is ON; "Inactive" means a load is not applied or a switch is OFF.

## Fig. 04.4

### COMPONENTS

Component	Connector / Type / Color	Location / Access
CAMSHAFT POSITION SENSOR (V12)	PI3 (FLY LEAD) / 2-WAY ECONOSEAL III LC / BLACK	A BANK CAMSHAFT COVER
ENGINE CONTROL MODULE (V12)	PI44 128-WAY MULTILOCK MO ISLATE PI45 116-WAY MULTILOCK MO ISLATE PI46 22-WAY MULTILOCK MO ISLATE PI47 34-WAY MULTILOCK 040 ISLATE	RH 'A' POST 'A' POST TRIM
ENGINE COOLANT TEMPERATURE SENSOR (V12)	PI5 / 2-WAY ECONOSEAL J / SLATE	B BANK THERMOSTAT HOUSING
ENGINE POSITION SENSOR	PI2 (FLY LEAD) / 2-WAY ECONOSEAL III LC / BLACK	ENGINE TIMING COVER
ENGINE SPEED SENSOR	PI23 (FLY LEAD) / 2-WAY ECONOSEAL III LC / BLACK	ENGINE VEE, REAR
FUEL PUMP III	BT6 (FLY LEAD) / 4-WAY SUMITOMO 90 / WHITE	FUEL TANK / FUEL TANK TRIM
FUEL PUMP (2)	BT6 (FLY LEAD) / 4-WAY SUMITOMO 90 / WHITE	FUEL TANK / FUEL TANK TRIM
HEATED OXYGEN SENSOR (V12 A DOWNSTREAM)	CA98 (FLY LEAD) / 4-WAY YAZAKI / WHITE	A BANK EXHAUST, DOWNSTREAM OF PRIMARY CATALYST
HEATED OXYGEN SENSOR (V12 A UPSTREAM)	PI25 (FLY LEAD) / 4-WAY SUMITOMO 90 ISLATE	A BANK EXHAUST, UPSTREAM OF PRIMARY CATALYST
HEATED OXYGEN SENSOR (V12 B DOWNSTREAM)	CA99 (FLY LEAD) / 4-WAY YAZAKI / WHITE	B BANK EXHAUST, DOWNSTREAM OF PRIMARY CATALYST
HEATED OXYGEN SENSOR (V12 B UPSTREAM)	PI27 (FLY LEAD) / 4-WAY SUMITOMO 90 / SLATE	B BANK EXHAUST, UPSTREAM OF PRIMARY CATALYST
IDLE AIR CONTROL VALVE (V12 A BANK)	PI28 / 3-WAY SUMITOMO 90 / SLATE	A BANK THROTTLE BODY
IDLE AIR CONTROL VALVE (V12 B BANK)	PI30 / 3-WAY SUMITOMO 90 / SLATE	B BANK THROTTLE BODY
INTAKE AIR TEMPERATURE SENSOR (V12)	PI6 / 2-WAY JUNIOR TIMER / BLACK	A BANK AIR INTAKE
MANIFOLD ABSOLUTE PRESSURE SENSOR (V12 A BANK)	PI9 / 3-WAY SUMITOMO 90 / BLACK	A BANK INTAKE MANIFOLD, REAR
MANIFOLD ABSOLUTE PRESSURE SENSOR (V12 B BANK)	PI50 13-WAY SUMITOMO 90 / BLACK	B BANK INTAKE MANIFOLD, REAR
THROTTLE POSITION SENSOR (V12)	PI7 14-WAY ECONOSEAL J / BLACK	THROTTLE TURNABLE

### RELAYS

Relay	Color / Stripe	Connector / Color	Location / Access
FUEL PUMP RELAY (1)	BLACK / VIOLET	BT26 1 GREEN	TRUNK ELECTRICAL CARRIER
FUEL PUMP RELAY (2)	BLUE	FU2 1 YELLOW	BATTERY COVER

### HARNESSTO-HARNESSTO CONNECTORS

Connector	Type / Color	Location / Access
BT4	THROUGH PANEL 148 MICRO / 6 / BLACK	PARCEL SHELF / FUEL TANK TRIM
FU1	6-WAY MULTILOCK 070 / WHITE	FUEL TANK TRIM / BATTERY COVER
PI1	13-WAY ECONOSEAL III LC / WHITE	RH AIR CLEANER
PI61	13-WAY ECONOSEAL III LC / BLACK	RH AIR CLEANER
PI73	2-WAY MULTILOCK 070 / YELLOW	RH 'A' POST / 'A' POST TRIM
PI74	8-WAY MULTILOCK 070 / YELLOW	RH 'A' POST, ECM / 'A' POST TRIM
RS3	THROUGH-PANEL 148 MICRO / 6 / BROWN	RH 'A' POST / 'A' POST PANEL

### GROUNDS

Ground	Location / Type
FUG8L	FRONT TRUNK GROUND S N D
FUG8R	FRONT TRUNK GROUND S N D
PIG75L	RH 'A' POST GROUND STUD
PIG75R	RH 'A' POST GROUND STUD
PIG76L	RH BULKHEAD GROUND STUD

### CONTROL MODULE PIN OUT INFORMATION (FOLD OUT PAGE)



REFER TO THE FRONT OF THE BOOK FOR ILLUSTRATIONS DETAILING THE LOCATION AND IDENTIFICATION OF COMPONENTS, RELAYS, CONNECTORS, HARNESSES, GROUNDS, VEHICLE CONTROL MODULES AND CONTROL MODULE PINS.

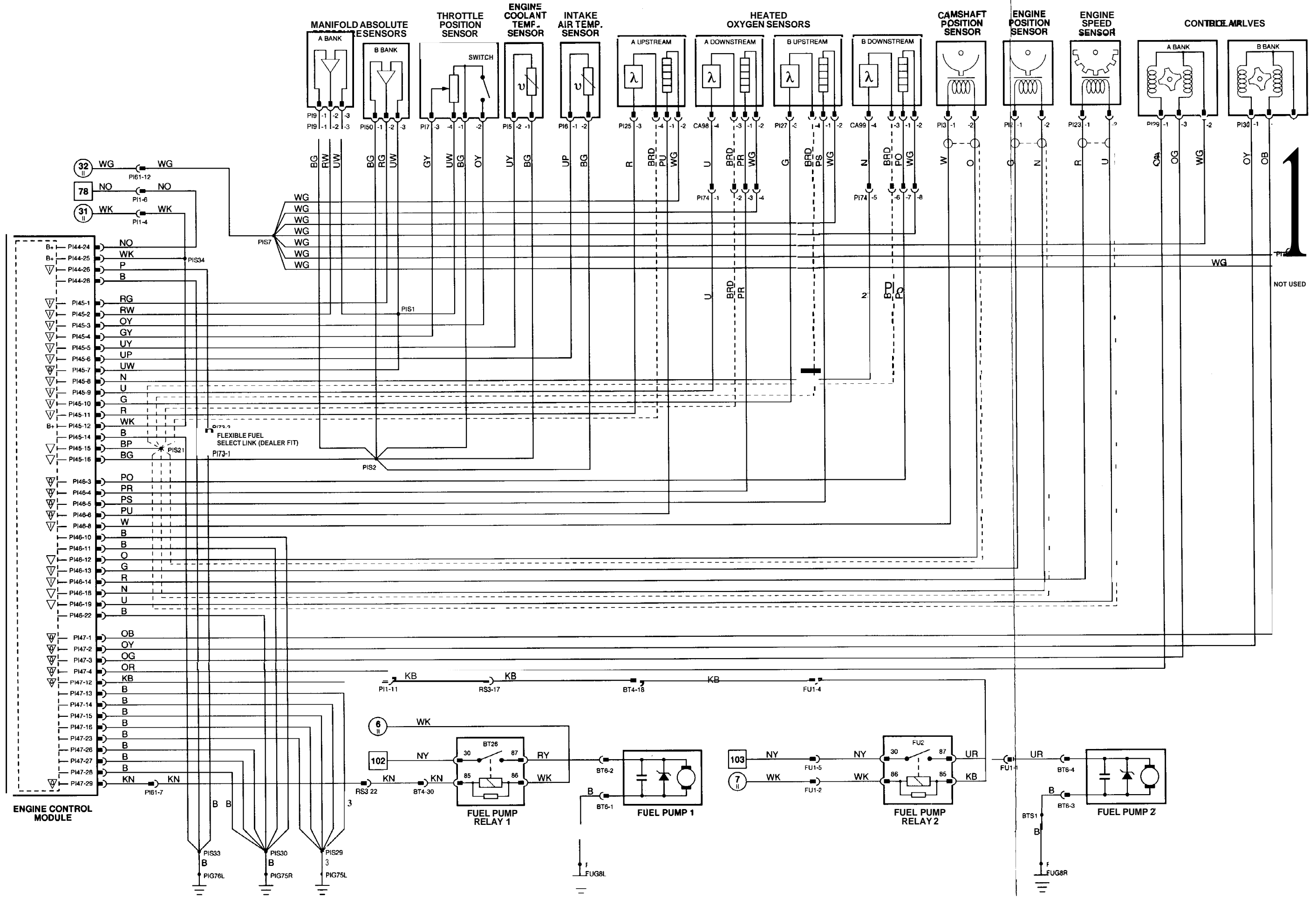

1  
NOT USED

## CONTROL MODULE PIN OUT INFORMATION

### ENGINE CONTROL MODULE (V12)

Pin	Description	Active	Inactive
0 P144-1	FUEL USED	GROUND PULSE, 10Hz @ IDLE	
0 P144-2	CHECK ENGINE MIL	GROUND	B+
0 P14-3	ENGINE TORQUE SIGNAL	11.5 V @ IDLE, DECREASING WITH TORQUE INCREASE	
0 P14-4	THROTTLE POSITION	1.4 V @ IDLE, 9 V @ FULL THROTTLE	
0 P144-5	LOADINHIBIT SIGNAL	GROUND	B+
I P144-6	TORQUE REDUCTION	GROUND PULSE @ SHIFT	11.5 V @ IDLE
I P144-7	VEHICLE SPEED	GROUND	B+
0 P144-10	ENGINE SPEED	5 V @ 1000 RPM = 45 Hz, 2000 RPM = 90 Hz	
I P144-12	ELECTRICAL OAD HEATED WINDSHIELD, HEATED BACKLIGHT, OR BLOWERS ON HIGH SPEED	GROUND	B+
I P14-13	AIR CONDITIONING REQUEST	B+	GROUND
D P144-14	FUELING INHIBIT SIGNAL	ENCODED COMMUNICATIONS	
I P144-18	PARK / NEUTRAL	GROUND	B+
I P14-21	FUEL LEVEL	B+	GROUND
D P144-22	SERIAL COMMUNICATION INPUT		
D P144-23	SERIAL COMMUNICATION OUTPUT		
I P144-26	FLEXIBLE FUEL SELECT LINK (DEALER FIT)	GROUND (FITTED)	B+
P145-13	POWER STEERING PRESSURE SWITCH	GROUND	B+
I P146-7	CRANK SIGNAL	GROUND	B+
0 P146-16	AIR CONDITIONING CLUTCH RELAY	GROUND	B+
0 P146-17	SECONDARY AIR INJECTION RELAY	GROUND	B+
I P146-20	IGNITION FAILURE - B BANK	B+	1.7 V
I P146-21	IGNITION FAILURE - A BANK	B+	1.7 V
0 P147-5	FUEL INJECTORS 3 5 5 - B BANK	GROUND PULSE, 3.5 MS @ IDLE	
0 P147-6	FUEL INJECTORS 2 & 4 - A BANK	GROUND PULSE, 3.5 MS @ IDLE	
0 P147-7	FUEL INJECTORS 1 & 4 - B BANK	GROUND PULSE, 3.5 MS @ IDLE	
0 P147-8	FUEL INJECTORS 3 5 6 - A BANK	GROUND PULSE, 1.5 MS @ IDLE	
0 P147-9	FUEL INJECTORS 2 5 6 - B BANK	GROUND PULSE, 3.5 MS @ IDLE	
0 P147-10	FUEL INJECTORS 1 5 5 - A BANK	GROUND PULSE, 3.5 MS @ IDLE	
0 P147-11	SECONDARY AIR VACUUM SOLENOID VALVE	B+	GROUND
0 P147-17	IGNITION MODULE NEGATIVE - 3B	GROUND PULSE, 1000 RPM = 15 Hz	
0 P147-18	IGNITION MODULE NEGATIVE - 2B	GROUND PULSE, 1000 RPM = 15 Hz	
0 P147-19	IGNITION MODULE NEGATIVE - 10	GROUND PULSE, 1000 RPM = 15 Hz	
0 P147-20	IGNITION MODULE NEGATIVE - 3A	GROUND PULSE, 1000 RPM = 15 Hz	
0 P147-21	IGNITION MODULE NEGATIVE - 2A	GROUND PULSE, 1000 RPM = 15 Hz	
0 P147-22	IGNITION MODULE NEGATIVE - 1A	GROUND PULSE, 1000 RPM = 15 Hz	
0 P147-33	EVAP VALVE - B BANK	B+	GROUND
0 P147-34	EVAP VALVE - A BANK	B+	GROUND

The following symbols are used to represent values for Control Module Pin Out data:

I Input	B+ Battery voltage
O output	V Voltage (DC)
SG Signal Ground	Hz Frequency
D Serial and encoded communications	KHz Frequency x 1000
	MS Milliseconds
	MV Millivolts

**CAUTION** The information on this data page is furnished to aid the user in understanding circuit operation. THIS INFORMATION SHOULD BE USED FOR REFERENCE ONLY.

**NOTE:** The values listed are approximately those that can be expected at the control module connector pins with all circuit connections made and all components connected and fitted. "Active" means a load is applied or a switch is ON; "Inactive" means a load is not applied or a switch is OFF.

## Fig. 04.5

### COMPONENTS

Component	Connector / Type / Color	Location / Access
DIODE (P181) - AIRP SOLENOID SUPPRESSION	P181 / DIODE / BLACK	EMS HARNESS / SECONDARY AIR INJECTION PUMP
ENGINE CONTROL MODULE (V12)	P144 128-WAY MULTILOCK MO / SLATE P145 / 16-WAY MULTILOCK MO / SLATE P146 / 22-WAY MULTILOCK 040 ISLATE P147 134-WAY MULTILOCK MO / SLATE	RH 'A' POST / 'A' POST TRIM
EVAPORATIVE EMISSION CONTROL VALVE (V12 A BANK)	P118 1 2-WAY JUNIOR TIMER / BLACK	BELOW LH FRONT RELAYS
EVAPORATIVE EMISSION CONTROL VALVE (V12 B BANK)	P119 / 2-WAY JUNIOR TIMER / BLACK	BELOW LH FRONT RELAYS
FUEL INJECTOR (V12 A BANK 11)	P132 / 2-WAY JUNIOR TIMER / SLATE	FUEL RAIL, INTAKE MANIFOLD
FUEL INJECTOR (V12 A BANK 21)	P133 / 2-WAY JUNIOR TIMER ISLATE	FUEL RAIL, INTAKE MANIFOLD
FUEL INJECTOR (V12 A BANK 31)	P134 / 2-WAY JUNIOR TIMER ISLATE	FUEL RAIL, INTAKE MANIFOLD
FUEL INJECTOR (V12 A BANK 41)	P135 / 2-WAY JUNIOR TIMER / SLATE	FUEL RAIL, INTAKE MANIFOLD
FUEL INJECTOR (V12 A BANK 51)	P136 12-WAY JUNIOR TIMER ISLATE	FUEL RAIL, INTAKE MANIFOLD
FUEL INJECTOR (V12 A BANK 61)	P137 / 2-WAY JUNIOR TIMER / SLATE	FUEL RAIL, INTAKE MANIFOLD
FUEL INJECTOR (V12 B BANK 11)	P138 12-WAY JUNIOR TIMER ISLATE	FUEL RAIL, INTAKE MANIFOLD
FUEL INJECTOR (V12 B BANK 21)	P139 12-WAY JUNIOR TIMER ISLATE	FUEL RAIL, INTAKE MANIFOLD
FUEL INJECTOR (V12 B BANK 31)	P140 / 2-WAY JUNIOR TIMER ISLATE	FUEL RAIL, INTAKE MANIFOLD
FUEL INJECTOR (V12 B BANK 41)	P141 / 2-WAY JUNIOR TIMER / SLATE	FUEL RAIL, INTAKE MANIFOLD
FUEL INJECTOR (V12 B BANK 51)	P142 / 2-WAY JUNIOR TIMER ISLATE	FUEL RAIL, INTAKE MANIFOLD
FUEL INJECTOR (V12 B BANK 61)	P143 / 2-WAY JUNIOR TIMER ISLATE	FUEL RAIL, INTAKE MANIFOLD
IGNITION COIL (V12 A BANK)	P112 / 4-WAY SUB-MINIATURE / BLACK	ENGINE VEE
IGNITION COIL (V12 B BANK)	P113 14-WAY SUB-MINIATURE BLACK	ENGINE VEE
IGNITION MODULE (V12 A BANK)	P110 / 8-WAY SUMITOMO 90 / SLATE	ENGINE BAY, RH INNER FENDER
IGNITION MODULE (V12 B BANK)	P111 18-WAY SUMITOMO 90 / SLATE	ENGINE BAY, RH INNER FENDER
POWER STEERING PRESSURE SWITCH	P168 / 2-WAY JUNIOR TIMER BLACK	POWER STEERING PUMP
SECONDARY AIR INJECTION CLUTCH	P121 (FLY LEAD) / 2-WAY ECONOSEAL III LC / BLACK	SECONDARY AIR INJECTION PUMP
SECONDARY AIR INJECTION SWITCHING VALVE	P122 12-WAY DENSO / BLUE	A BANK INTAKE MANIFOLD REAR

### RELAYS

Relay	Color / Stripe	Connector / Color	Location / Access
FUEL INJECTOR RELAY (MAIN RELAY) (V12)	BLACK	P120 / BLACK	RH ENGINE BAY RELAYS
IGNITION COIL RELAY (V12)	BLACK	P153 BLACK	RH ENGINE BAY RELAYS
SECONDARY AIR INJECTION RELAY (V12)	BLACK / WHITE	P152 / BLACK	RH ENGINE BAY RELAYS

### HARNESSTO-HARNESCONNECTORS

Connector	Type / Color	Location / Access
P11	13-WAY ECONOSEAL III LC / WHITE	RH AIR CLEANER
P159	13-WAY ECONOSEAL III LC BLACK	LH AIR CLEANER
P161	13-WAY ECONOSEAL III LC / BLACK	RH AIR CLEANER
P163	20-WAY MULTILOCK 040 / BLACK	RH 'A' POST / 'A' POST TRIM
P173	2-WAY MULTILOCK 070 / YELLOW	RH 'A' POST / 'A' POST TRIM

### GROUNDS

Ground	Location / Type
PIG75L	RH 'A' POST GROUND STUD
PIG75R	RH 'A' POST GROUND STUD
PIG76L	RH BULKHEAD GROUND STUD
PIG77R	RIGHT FORWARD EMS GROUND STUD

### CONTROL MODULE PIN OUT INFORMATION (FOLD OUT PAGE)



REFER TO THE FRONT OF THE BOOK FOR ILLUSTRATIONS DETAILING THE LOCATION AND IDENTIFICATION OF COMPONENTS, RELAYS, CONNECTORS, HARNESSES, GROUNDS, VEHICLE CONTROL MODULES AND CONTROL MODULE PINS.

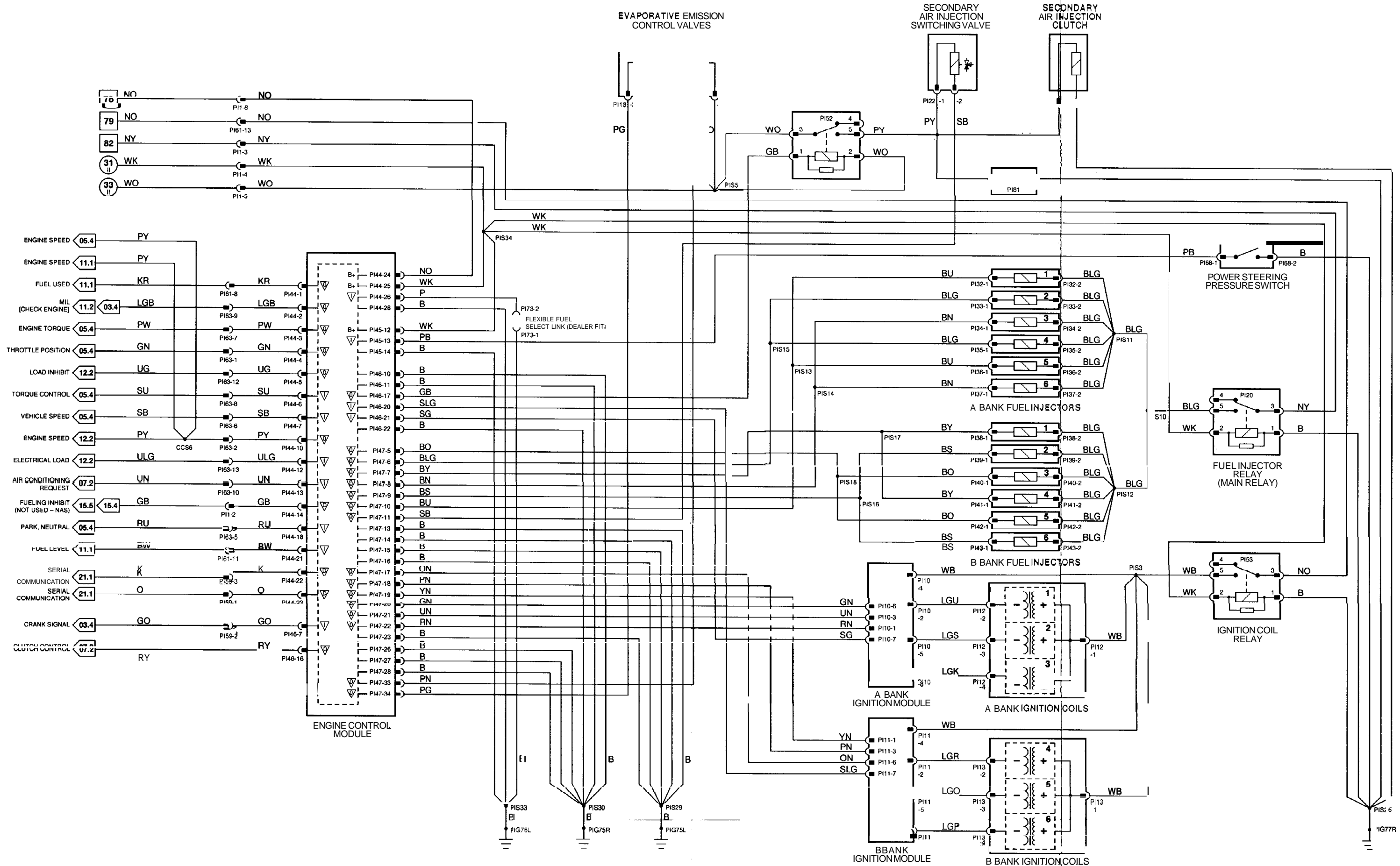

## CONTROL MODULE PIN OUT INFORMATION

### ENGINE CONTROL MODULE (V12)

Pin	Description	Active	Inactive
I P144-26	FLEXIBLE FUEL SELECT LINK (DEALER FIT)	GROUND (FITTED)	B+
I P145-1	MAP SENSOR FEEDBACK - B BANK	1.1 V @ IDLE. INCREASING WITH MANIFOLD ABSOLUTE PRESSURE	
I P1G-2	MAP SENSOR FEEDBACK - A BANK	1.1 V @ IDLE. INCREASING WITH MANIFOLD ABSOLUTE PRESSURE	
I P18-3	IDLE SWITCH	GROUND	B+
I P145-4	THROTTLE POSITION SENSOR FEEDBACK VOLTAGE	0.58 V @ IDLE. 4.75 V @ FULL THROTTLE	
I P145-5	COOLANT TEMPERATURE SENSOR	0.41 V @ 90° C, INCREASING WITH TEMPERATURE	
I P145-6	INTAKE AIR TEMPERATURE SENSOR	0.59 V @ 10° C, INCREASING WITH TEMPERATURE	
O P145-7	COMMON SENSOR REFERENCE VOLTAGE	5 V	5 v
I P145-10	UPSTREAM HOZS FEEDBACK - B BANK	0.1 - 0.8 V (SWING)	
I P145-11	UPSTREAM HOZS FEEDBACK - A BANK	0.1 - 0.8 V (SWING)	
SG P145-15	COMMON SENSOR SHIELD GROUND	GROUND	GROUND
SG P145-16	COMMON SENSOR REFERENCE GROUND	GROUND	GROUND
O P146-5	UPSTREAM HOZS HEATER GROUND - B BANK	GROUND	B+
O P146-6	UPSTREAM HOZS HEATER GROUND - A BANK	GROUND	B+
I P146-8	CAMSHAFT POSITION SENSOR	GROUND PULSE @ 1000 RPM = 8 Hz, 2000 RPM = 16 Hz	
SG P146-12	CAMSHAFT POSITION SENSOR	GROUND	GROUND
I P146-13	ENGINE POSITION SENSOR	GROUND PULSE @ 1000 RPM = 15 Hz, 2000 RPM = 30 Hz	
I P146-14	ENGINE SPEED SENSOR	GROUND PULSE @ 1000 RPM = 175 Hz, 2000 RPM = 350 Hz	
SG P146-18	ENGINE POSITION SENSOR	GROUND	GROUND
SG P146-19	ENGINE SPEED SENSOR	GROUND	GROUND
O P147-1	IDLE AIR CONTROL VALVE CLOSE - B BANK	4.6 V @ IDLE	
O P147-2	IDLE AIR CONTROL VALVE OPEN - B BANK	9.8 V @ IDLE	
O P147-3	IDLE AIR CONTROL VALVE CLOSE - A BANK	4.6 V @ IDLE	
O P147-4	IDLE AIR CONTROL VALVE OPEN - A BANK	9.8 V @ IDLE	
O P147-12	FUEL PUMP RELAY 2	GROUND	B+
O P147-29	FUEL PUMP RELAY 1	GROUND	B+

The following symbols are used to represent values for Control Module Pin Out data:

I	<b>Input</b>	B+	<b>Battery voltage</b>
O	<b>Output</b>	V	<b>Voltage (DC)</b>
SG	<b>Signal Ground</b>	Hz	<b>Frequency</b>
D	<b>Serial and encoded communications</b>	KHz	<b>Frequency x 1000</b>
		MS	<b>Milliseconds</b>
		MV	<b>Millivolts</b>

**CAUTION:** The information on this data page is furnished to aid the user in understanding circuit operation. THIS INFORMATION SHOULD BE USED FOR REFERENCE ONLY.

**NOTE:** The values listed are approximately those that can be expected at the control module connector pins with all circuit connections made and all components connected and fitted. "Active" means a load is applied or a switch is ON; "Inactive" means a load is not applied or a switch is OFF.

## Fig. 04.6

### COMPONENTS

Component	Connector / Type / Color	Location / Access
CAMSHAFT POSITION SENSOR (V12)	P13 (FLY LEAD) / 2-WAY ECONOSEAL III LC / BLACK	A BANK CAM SHAFT COVER
CATALYST SWITCHING MODULE	P155 / 8-WAY MULTILOCK 070 / WHITE	RH 'A' POST, ECM / 'A' POST TRIM
CATALYST THERMOCOUPLES	P156 (FLY LEAD) / 4-WAY ECONOSEAL III LC / BLACK	REAR OF ENGINE
ENGINE CONTROL MODULE (V12)	P144 / 26-WAY MULTILOCK MO / SLATE P145 / 16-WAY MULTILOCK 040 / SLATE P146 / 22-WAY MULTILOCK 040 / SLATE P147 / 34-WAY MULTILOCK 040 / SLATE	RH 'A' POST / 'A' POST TRIM
ENGINE COOLANT TEMPERATURE SENSOR (V12)	P15 / 2-WAY ECONOSEAL J / SLATE	B BANK THERMOSTAT HOUSING
ENGINE POSITION SENSOR	P12 (FLY LEAD) / 12-WAY ECONOSEAL III LC / BLACK	ENGINE TIMING COVER
ENGINE SPEED SENSOR	P123 (FLY LEAD) / 2-WAY ECONOSEAL III LC / BLACK	ENGINE M.E. REAR
FUEL PUMP (1)	B76 (FLY LEAD) / 14-WAY SUMITOMO 90 / WHITE	FUEL TANK / FUEL TANK TRIM
FUEL PUMP (2)	B76 (FLY LEAD) / 14-WAY SUMITOMO 90 / WHITE	FUEL TANK / FUEL TANK TRIM
HEATED OXYGEN SENSOR (V12 A BANK)	P125 (FLY LEAD) / 4-WAY SUMITOMO 90 / SLATE	A BANK EXHAUST, DOWNSTREAM OF PRIMARY CATALYST
HEATED OXYGEN SENSOR (V12 B BANK)	P127 (FLY LEAD) / 4-WAY SUMITOMO 90 / SLATE	B BANK EXHAUST, DOWNSTREAM OF PRIMARY CATALYST
IDLE AIR CONTROL VALVE (V12 A BANK)	P129 / 3-WAY SUMITOMO 90 / SLATE	A BANK THROTTLE BODY
IDLE AIR CONTROL VALVE (V12 B BANK)	P130 / 3-WAY SUMITOMO 90 / SLATE	B BANK THROTTLE BODY
INTAKE AIR TEMPERATURE SENSOR (V12)	P16 / 2-WAY JUNIOR TIMER / BLACK	A BANK AIR INTAKE
MANIFOLD ABSOLUTE PRESSURE SENSOR (V12 A BANK)	P19 / 3-WAY SUMITOMO 90 / BLACK	A BANK INTAKE MANIFOLD, REAR
MANIFOLD ABSOLUTE PRESSURE SENSOR (V12 B BANK)	P150 / 3-WAY SUMITOMO 90 / BLACK	B BANK INTAKE MANIFOLD, REAR
THROTTLE POSITION SENSOR (V12)	P17 / 4-WAY ECONOSEAL J / BLACK	THROTTLE TURN TABLE

### RELAYS

Relay	Color / Stripe	Connector / Color	Location / Access
FUEL PUMP RELAY (1)	BLACK / VIOLET	B726 / GREEN	TRUNK ELECTRICAL CARRIER
FUEL PUMP RELAY (2)	BLUE	FUY YELLOW	BATTERY COVER

### HARNESSTO-HARNESCONNECTORS

Connector	Type / Color	Location / Access
BT4	THROUGH-PANEL (48 MICRO / 6) / BLACK	PARCELSHELF / FUEL TANK TRIM
FU1	6-WAY MULTILOCK 070 / WHITE	FUEL TANK TRIM / BATTERY COVER
P1	13-WAY ECONOSEAL III LC / WHITE	RH AIR CLEANER
P161	13-WAY ECONOSEAL III LC / BLACK	RH AIR CLEANER
P173	2-WAY MULTILOCK 070 / YELLOW	RH 'A' POST / 'A' POST TRIM
RS3	THROUGH-PANEL (48 MICRO / 6) / BROWN	RH 'A' POST / 'A' POST PANEL

### GROUNDS

Ground	Location / Type
FUG8L	FRONT TRUNK GROUND STUD
FUG8R	FRONT TRUNK GROUND STUD
PIG75L	RH 'A' POST GROUND STUD
PIG75R	RH 'A' POST GROUND STUD
PIG76L	RH BULKHEAD GROUND STUD
PIG76R	RH BULKHEAD GROUND STUD

### CONTROL MODULE PIN OUT INFORMATION (FOLD OUT PAGE)



REFER TO THE FRONT OF THE BOOK FOR ILLUSTRATIONS DETAILING THE LOCATION AND IDENTIFICATION OF COMPONENTS, RELAYS, CONNECTORS, HARNESSES, GROUNDS, VEHICLE CONTROL MODULES AND CONTROL MODULE PINS.

DATE OF ISSUE: JANUARY 1996



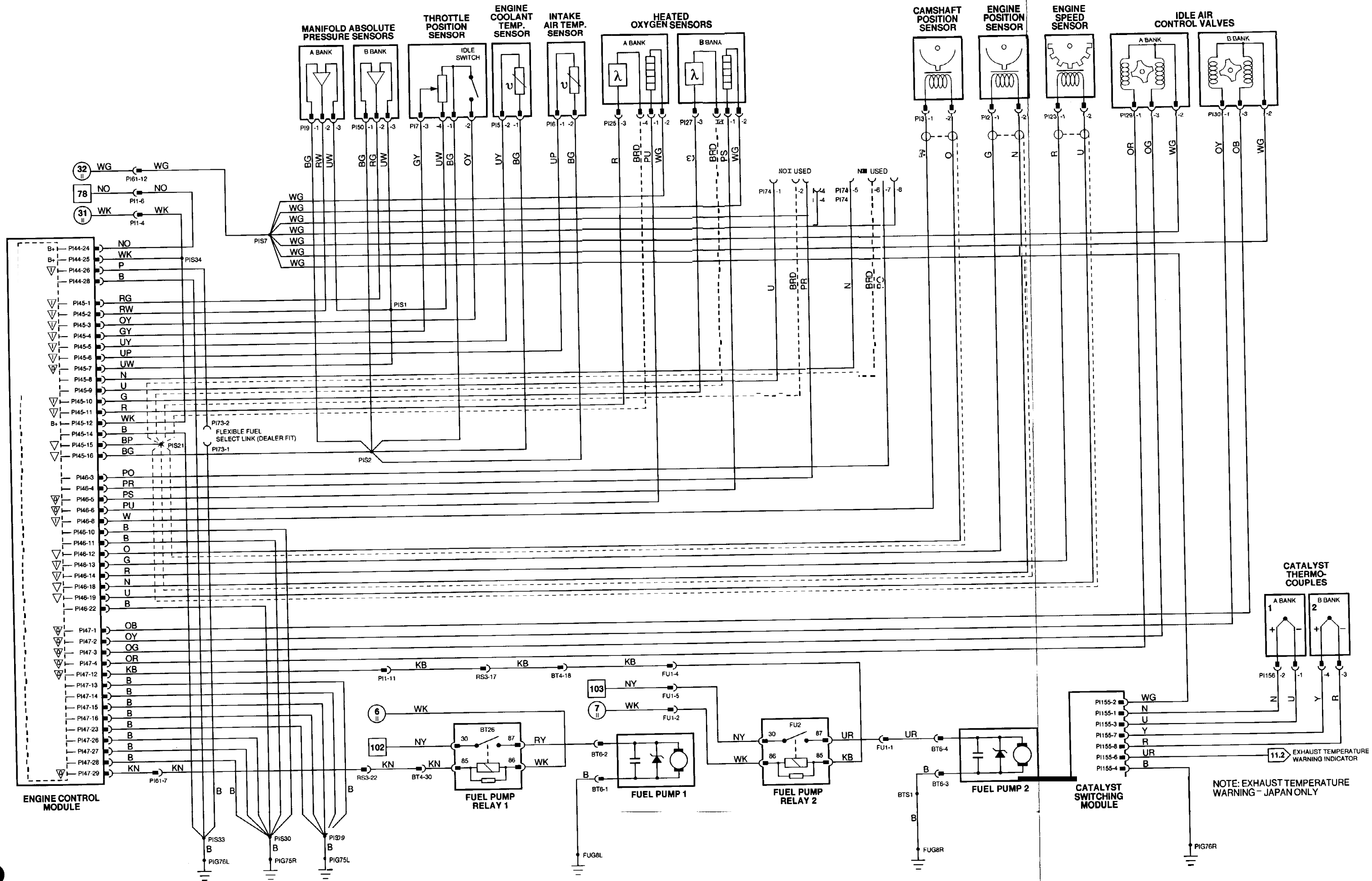

**CONTROL MODULE PIN OUT INFORMATION**

**ENGINE CONTROL MODULE (V12)**

Pin	Description	Active	Inactive
O PIU-1	FUEL USED	GROUND PULSE, 10 Hz @ IDLE	
O P144-2	CHECK ENGINE MIL	GROUND	B+
O P144-3	ENGINE TORQUE SIGNAL	11.5 V @ IDLE, DECREASING WITH TORQUE INCREASE	
O PIU-4	THROTTLE POSITION	14 V @ IDLE, 9 V @ FULL THROTTLE	
O PIU-5	LOAD INHIBIT SIGNAL	GROUND	B+
I PIU-6	TORQUE REDUCTION	GROUND PULSE @ SHIFT	115 V @ IDLE
I PIU-7	VEHICLE SPEED	GROUND	B+
O P144-10	ENGINE SPEED	5 V @ 1000 RPM = 45 Hz, 2000 RPM = 90 Hz	
O P144-12	ELECTRICAL LOAD: HEATER/WINDOWSHEILD, HEATER/BACKLIGHT, OR BLOWERS ON HIGH SPEED	GROUND	B+
I PIU-13	AIR CONDITIONING REQUEST	B+	GROUND
D P144-14	FUELING INHIBIT SIGNAL	ENCODED COMMUNICATIONS	
I P144-18	PARK/NEUTRAL	GROUND	B+
I P144-21	FUEL LEVEL	B+	GROUND
D P144-22	SERIAL COMMUNICATION INPUT		
D PIU-23	SERIAL COMMUNICATION OUTPUT		
I P144-26	FLEXIBLE FUEL SELECT LINK (DEALER FIT)	GROUND (FITTED)	B+
I PUS-13	POWER STEERING PRESSURE SWITCH	GROUND	B+
I P146-7	CRANK SIGNAL	GROUND	B+
O PIU-16	AIR CONDITIONING CLUTCH RELAY	GROUND	B+
O P146-17	SECONDARY AIR INJECTION RELAY	GROUND	B+
I P146-20	IGNITION FAILURE - B BANK	B+	1.7 V
I PUB-21	IGNITION FAILURE - A BANK	B+	1.7 V
O P147-5	FUEL INJECTORS 3 & 5 - B BANK	GROUND PULSE, 3.5 MS @ IDLE	
O P147-6	FUEL INJECTORS 2 & 4 - A BANK	GROUND PULSE, 3.5 MS @ IDLE	
O P147-7	FUEL INJECTORS 1 & 4 - B BANK	GROUND PULSE, 3.5 MS @ IDLE	
O P147-8	FUEL INJECTORS 3 & 6 - A BANK	GROUND PULSE, 3.5 MS @ IDLE	
O P147-9	FUEL INJECTORS 2 & 6 - B BANK	GROUND PULSE, 3.5 MS @ IDLE	
O P147-10	FUEL INJECTORS 1 & 5 - A BANK	GROUND PULSE, 3.5 MS @ IDLE	
O P147-11	SECONDARY AIR VACUUM SOLENOID VALVE	B+	GROUND
O P147-17	IGNITION MODULE NEGATIVE - 3B	GROUND PULSE, 1000 RPM = 15 Hz	
O P147-18	IGNITION MODULE NEGATIVE - 2B	GROUND PULSE, 1000 RPM = 15 Hz	
O PU7-19	IGNITION MODULE NEGATIVE - 1B	GROUND PULSE, 1000 RPM = 15 Hz	
O PU7-20	IGNITION MODULE NEGATIVE - 3A	GROUND PULSE, 1000 RPM = 15 Hz	
O PU7-21	IGNITION MODULE NEGATIVE - 2A	GROUND PULSE, 1000 RPM = 15 Hz	
O PU7-22	IGNITION MODULE NEGATIVE - 1A	GROUND PULSE, 1000 RPM = 15 Hz	
O P147-33	EVAP VALVE - B BANK	B+	GROUND
O P147-34	EVAP VALVE - A BANK	B+	GROUND

**Fig. 04.7**

**COMPONENTS**

Component	Connector / Type / Color	Location / Access
DIODE (P181) - AIRP SOLENOID SUPPRESSION ENGINE CONTROL MODULE (V12)	P181 MODE I BLACK P144 / 28-WAY MULTILOCK 040 / SLATE P145 / 16-WAY MULTILOCK 040 / SLATE P146 / 22-WAY MULTILOCK 040 / SLATE P147 / 34-WAY MULTILOCK 040 / SLATE	EMS HARNESS/SECONDARY AIR INJECTION PUMP RH 'A' POST / 'A' POST TRIM
EVAPORATIVE EMISSION CONTROL VALVE (V12 A BANK) EVAPORATIVE EMISSION CONTROL VALVE (V12 B BANK)	P118 / 2-WAY JUNIOR TIMER / BLACK P119 / 2-WAY JUNIOR TIMER / BLACK P132 / 2-WAY JUNIOR TIMER / SLATE P133 / 2-WAY JUNIOR TIMER / SLATE P134 / 2-WAY JUNIOR TIMER / SLATE P135 / 2-WAY JUNIOR TIMER / SLATE P136 / 2-WAY JUNIOR TIMER / SLATE P137 / 2-WAY JUNIOR TIMER / SLATE P138 / 2-WAY JUNIOR TIMER / SLATE P139 / 2-WAY JUNIOR TIMER / SLATE P140 / 2-WAY JUNIOR TIMER / SLATE P141 12-WAY JUNIOR TIMER / SLATE P142 / 2-WAY JUNIOR TIMER / SLATE P143 / 2-WAY JUNIOR TIMER / SLATE P112 14-WAY SUB-MINIATURE / BLACK P113 / 4-WAY SUB-MINIATURE / BLACK P110 / 8-WAY SUMITOMO 90 / SLATE P111 / 8-WAY SUMITOMO 90 / SLATE P168 / 2-WAY JUNIOR TIMER / BLACK P121 (FLY LEAD) / 2-WAY ECONOSEAL III LC / BLACK P122 12-WAY DENSO / BLUE	BELOW LH FRONT RELAYS BELOW LH FRONT RELAYS FUEL RAIL, INTAKE MANIFOLD FUEL RAIL, INTAKE MANIFOLD FUEL RAIL, INTAKE MANIFOLD FUEL RAIL, INTAKE MANIFOLD FUEL RAIL, INTAKE MANIFOLD FUEL RAIL, INTAKE MANIFOLD FUEL RAIL, INTAKE MANIFOLD FUEL RAIL, INTAKE MANIFOLD FUEL RAIL, INTAKE MANIFOLD FUEL RAIL, INTAKE MANIFOLD FUEL RAIL, INTAKE MANIFOLD FUEL RAIL, INTAKE MANIFOLD ENGINE VEE ENGINE BAY, RH INNER FENDER ENGINE BAY, RH INNER FENDER POWER STEERING PUMP SECONDARY AIR INJECTION PUMP A BANK INTAKE MANIFOLD / REAR

**RELAYS**

Relay	Color / Stripe	Connector / Color	Location / Access
FUEL INJECTOR RELAY (MAIN RELAY) (V12)	BLACK	P120 / BLACK	RH ENGINE BAY RELAYS
IGNITION COIL RELAY (V12)	BLACK	P153 / BLACK	RH ENGINE BAY RELAYS
SECONDARY AIR INJECTION RELAY (V12)	BLACK / WHITE	P152 / BLACK	RH ENGINE BAY RELAYS

**HARNESSTO-HARNESSTO CONNECTORS**

Connector	Type / Color	Location / Access
P11	13-WAY ECONOSEAL III LC / WHITE	RH AIR CLEANER
P159	13-WAY ECONOSEAL III LC / BLACK	LH AIR CLEANER
P161	13-WAY ECONOSEAL III LC / BLACK	RH AIR CLEANER
P163	20-WAY MULTILOCK 040 / BLACK	RH 'A' POST / 'A' POST TRIM
P173	2-WAY MULTILOCK 0701 / YELLOW	RH 'A' POST / 'A' POST TRIM

**GROUNDS**

Ground	Location / Type
PIG75L	RH 'A' POST GROUND STUD
PIG75R	RH 'A' POST GROUND STUD
PIG76L	RH BULKHEAD GROUND STUD
PIG77R	RIGHT FORWARD EMS GROUND STUD

**CONTROL MODULE PIN OUT INFORMATION (FOLD OUT PAGE)**



The following symbols are used to represent values for Control Module Pin Out data:

<b>I</b> Input	<b>B+</b> Battery voltage
<b>O</b> Output	<b>V</b> Voltage (DC)
<b>SG</b> Signal Ground	<b>Hz</b> Frequency
<b>D</b> Serial and encoded communications	<b>KHz</b> Frequency x 1000
	<b>MS</b> Milliseconds
	<b>MV</b> Millivolts

**CAUTION** The information on this data page is furnished to aid the user in understanding circuit operation. THIS INFORMATION SHOULD BE USED FOR REFERENCE ONLY.

**NOTE:** The values listed are approximately those that can be expected at the control module connector pins with all circuit connections made and all components connected and fitted. "Active" means a load is applied or a switch is ON; "Inactive" means a load is not applied or a switch is OFF.

REFER TO THE FRONT OF THE BOOK FOR ILLUSTRATIONS DETAILING THE LOCATION AND IDENTIFICATION OF COMPONENTS, RELAYS, AND CONTROL MODULE PINS.

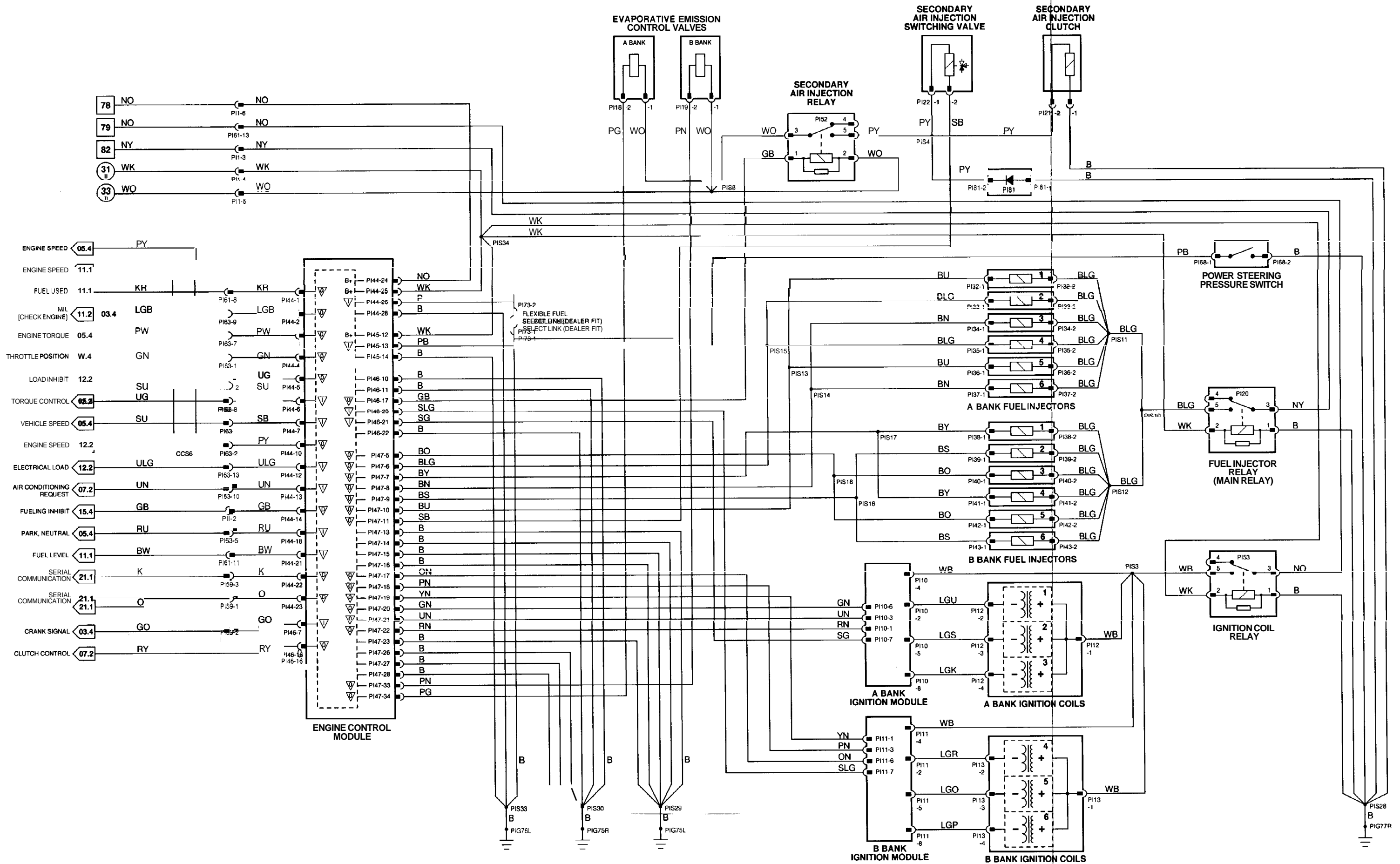

## CONTROL MODULE PIN OUT INFORMATION

### ENGINE CONTROL MODULE (V12)

Pin	Description	Active	Inactive
I P144-26	FLEXIBLE FUEL SELECT LINK (DEALER FIT)	GROUND (FITTED)	B+
I P145-1	MAP SENSOR FEEDBACK - B BANK	1.7 V @ IDLE, INCREASING WITH MANIFOLD ABSOLUTE PRESSURE	B+
I P145-2	MAP SENSOR FEEDBACK - A BANK	1.7 V @ IDLE, INCREASING WITH MANIFOLD ABSOLUTE PRESSURE	B+
I P145-3	IDLE SWITCH	GROUND	B+
I P145-4	THROTTLE POSITION SENSOR FEEDBACK VOLTAGE	0.58 V @ IDLE, 4.75 V @ FULL THROTTLE	B+
I P145-5	COOLANT TEMPERATURE SENSOR	0.41 V @ 90° C. INCREASING WITH TEMPERATURE	B+
I P145-6	INTAKE AIR TEMPERATURE SENSOR	0.59 V @ 10° C. INCREASING WITH TEMPERATURE	B+
O P145-7	COMMON SENSOR REFERENCE VOLTAGE	5 v	B+
I P145-8	DOWNSTREAM HO2S FEEDBACK - B BANK	0.1 - 0.8 V (SWING)	B+
I P145-9	DOWNSTREAM HO2S FEEDBACK - A BANK	0.1 - 0.8 V (SWING)	B+
I P145-10	UPSTREAM HO2S FEEDBACK - B BANK	0.1 - 0.8 V (SWING)	B+
I P145-11	UPSTREAM HO2S FEEDBACK - A BANK	0.1 - 0.8 V (SWING)	B+
SG P145-15	COMMON SENSOR SHIELD GROUND	GROUND	B+
SG P145-16	COMMON SENSOR REFERENCE GROUND	GROUND	B+
O P146-3	DOWNSTREAM HO2S HEATER GROUND - B BANK	GROUND	B+
O P146-4	DOWNSTREAM HO2S HEATER GROUND - A BANK	GROUND	B+
O P146-5	UPSTREAM HO2S HEATER GROUND - B BANK	GROUND	B+
O P146-6	UPSTREAM HO2S HEATER GROUND - A BANK	GROUND	B+
I P146-8	CAMSHAFT POSITION SENSOR	GROUND PULSE @ 1000 RPM = 8 Hz, 2000 RPM = 18 Hz	B+
SG P146-12	CAMSHAFT POSITION SENSOR	GROUND	B+
I P146-13	ENGINE POSITION SENSOR	GROUND PULSE @ 1000 RPM = 15 Hz, 2000 RPM = 30 Hz	B+
I P146-14	ENGINE SPEED SENSOR	GROUND PULSE @ 1000 RPM = 175 Hz, 2000 RPM = 350 Hz	B+
SG P146-18	ENGINE POSITION SENSOR	GROUND	B+
SG P146-19	ENGINE SPEED SENSOR	GROUND	B+
O P147-1	IDLE AIR CONTROL VALVE CLOSE - B BANK	4.8 V @ IDLE	B+
O P147-2	IDLE AIR CONTROL VALVE OPEN - B BANK	9.8 V @ IDLE	B+
O P147-3	IDLE AIR CONTROL VALVE CLOSE - A BANK	4.8 V @ IDLE	B+
O P147-4	IDLE AIR CONTROL VALVE OPEN - A BANK	9.8 V @ IDLE	B+
O P147-12	FUEL PUMP RELAY 2	GROUND	B+
O PY7-29	FUEL PUMP RELAY 1	GROUND	B+

## Fig. 04.8

### COMPONENTS

Component	Connector / Type / Color	Location / Access
CAMSHAFT POSITION SENSOR (V12)	P13 (FLY LEAD) / 2-WAY ECONOSEAL III LC / BLACK	A BANK CAMSHAFT COVER
ENGINE CONTROL MODULE (V12)	P144 / 28-WAY MULTILOCK 040 / SLATE P145 / 116-WAY MULTILOCK MD / SLATE P146 / 22-WAY MULTILOCK 040 / SLATE P147 / 31-WAY MULTILOCK MD / SLATE	RH 'A' POST / 'A' POST TRIM
ENGINE COOLANT TEMPERATURE SENSOR (V12)	P15 / 2-WAY ECONOSEAL J / SLATE	B BANK THERMOSTAT HOUSING
ENGINE POSITION SENSOR	P12 (FLY LEAD) / 12-WAY ECONOSEAL III LC / BLACK	ENGINE TIMING COVER
ENGINE SPEED SENSOR	P123 (FLY LEAD) / 12-WAY ECONOSEAL III LC / BLACK	ENGINE ME, REAR
FUEL PUMP III	BT6 (FLY LEAD) / 4-WAY SUMITOMO 90 / WHITE	FUEL TANK / FUEL TANK TRIM
FUEL PUMP (2)	BT6 (FLY LEAD) / 14-WAY SUMITOMO 90 / WHITE	FUEL TANK / FUEL TANK TRIM
HEATED OXYGEN SENSOR (V12 A DOWNSTREAM)	CA98 (FLY LEAD) / 4-WAY YAZAKI / WHITE	A BANK EXHAUST. DOWNSTREAM OF PRIMARY CATALYST
HEATED OXYGEN SENSOR (V12 A UPSTREAM)	P125 (FLY LEAD) / 14-WAY SUMITOMO 90 / SLATE	A BANK EXHAUST. UPSTREAM OF PRIMARY CATALYST
HEATED OXYGEN SENSOR (V12 B DOWNSTREAM)	CA99 (FLY LEAD) / 4-WAY YAZAKI / WHITE	B BANK EXHAUST. DOWNSTREAM OF PRIMARY CATALYST
HEATED OXYGEN SENSOR (V12 B UPSTREAM)	P127 (FLY LEAD) / 14-WAY SUMITOMO 90 / SLATE	B BANK EXHAUST. UPSTREAM OF PRIMARY CATALYST
IDLE AIR CONTROL VALVE (V12 A BANK)	P129 / 3-WAY SUMITOMO 90 / SLATE	A BANK THROTTLE BODY
IDLE AIR CONTROL VALVE (V12 B BANK)	P130 / 13-WAY SUMITOMO 90 / SLATE	B BANK THROTTLE BODY
INTAKE AIR TEMPERATURE SENSOR (V12)	P18 / 12-WAY JUNIOR TIMER / BLACK	A BANK AIR INTAKE
MANIFOLD ABSOLUTE PRESSURE SENSOR (V12 A BANK)	P19 / 3-WAY SUMITOMO 90 / BLACK	A BANK INTAKE MANIFOLD, REAR
MANIFOLD ABSOLUTE PRESSURE SENSOR (V12 B BANK)	P150 / 3-WAY SUMITOMO 90 / BLACK	B BANK INTAKE MANIFOLD, REAR
THROTTLE POSITION SENSOR (V12)	P17 / 14-WAY ECONOSEAL J / BLACK	THROTTLE TURN TABLE

### RELAYS

Relay	Color / Stripe	Connector / Color	Location / Access
FUEL PUMP RELAY (1)	BLACK / VIOLET	BT26 / GREEN	TRUNK ELECTRICAL CARRIER
FUEL PUMP RELAY (2)	BLUE	FUY YELLOW	BATTERY COVER

### HARNESSTO-HARNESSTO CONNECTORS

Connector	Type / Color	Location / Access
BT4	THROUGH-PANEL 148 MICRO / 6 / BLACK	PARCEL SHELF / FUEL TANK TRIM
FU1	8-WAY MULTILOCK 0701 WHITE	FUEL TANK TRIM / BATTERY COVER
PI1	13-WAY ECONOSEAL III LC / WHITE	RH AIR CLEANER
PI61	13-WAY ECONOSEAL III LC / BLACK	RH AIR CLEANER
PI73	2-WAY MULTILOCK 0701 YELLOW	RH 'A' POST / 'A' POST TRIM
PI74	8-WAY MULTILOCK 070 / YELLOW	RH "A" POST, ECM / 'A' POST TRIM
RS3	THROUGH-PANEL 148 MICRO / 6 / BROWN	RH 'A' POST / 'A' POST PANEL

### GROUNDS

Ground	Location / Type
FUG8L	FRONT TRUNK GROUND STUD
FUG8R	FRONT TRUNK GROUND STUD
PIG75L	RH 'A' POST GROUND STUD
PIG75R	RH 'A' POST GROUND STUD
PIG76L	RH BULKHEAD GROUND STUD

### CONTROL MODULE PIN OUT INFORMATION (FOLD OUT PAGE)



The following symbols are used to represent values for Control Module Pin Out data:

I Input	B+ Battery voltage
O output	V Voltage (DC)
SG Signal Ground	Hz Frequency
D Serial and encoded communications	KHz Frequency x 1000
	MS Milliseconds
	MV Millivolts

**CAUTION** The information on this data page is furnished to aid the user in understanding circuit operation. THIS INFORMATION SHOULD BE USED FOR REFERENCE ONLY.

**NOTE:** The values listed are approximately those that can be expected at the control module connector pins with all circuit connections made and all components connected and fitted. "Active" means a load is applied or a switch is ON; "Inactive" means a load is not applied or a switch is OFF.

REFER TO THE FRONT OF THE BOOK FOR ILLUSTRATIONS DETAILING THE LOCATION AND IDENTIFICATION OF COMPONENTS, RELAYS, CONNECTORS, HARNESSES, GROUNDS, VEHICLE CONTROL MODULES AND CONTROL MODULE PINS.

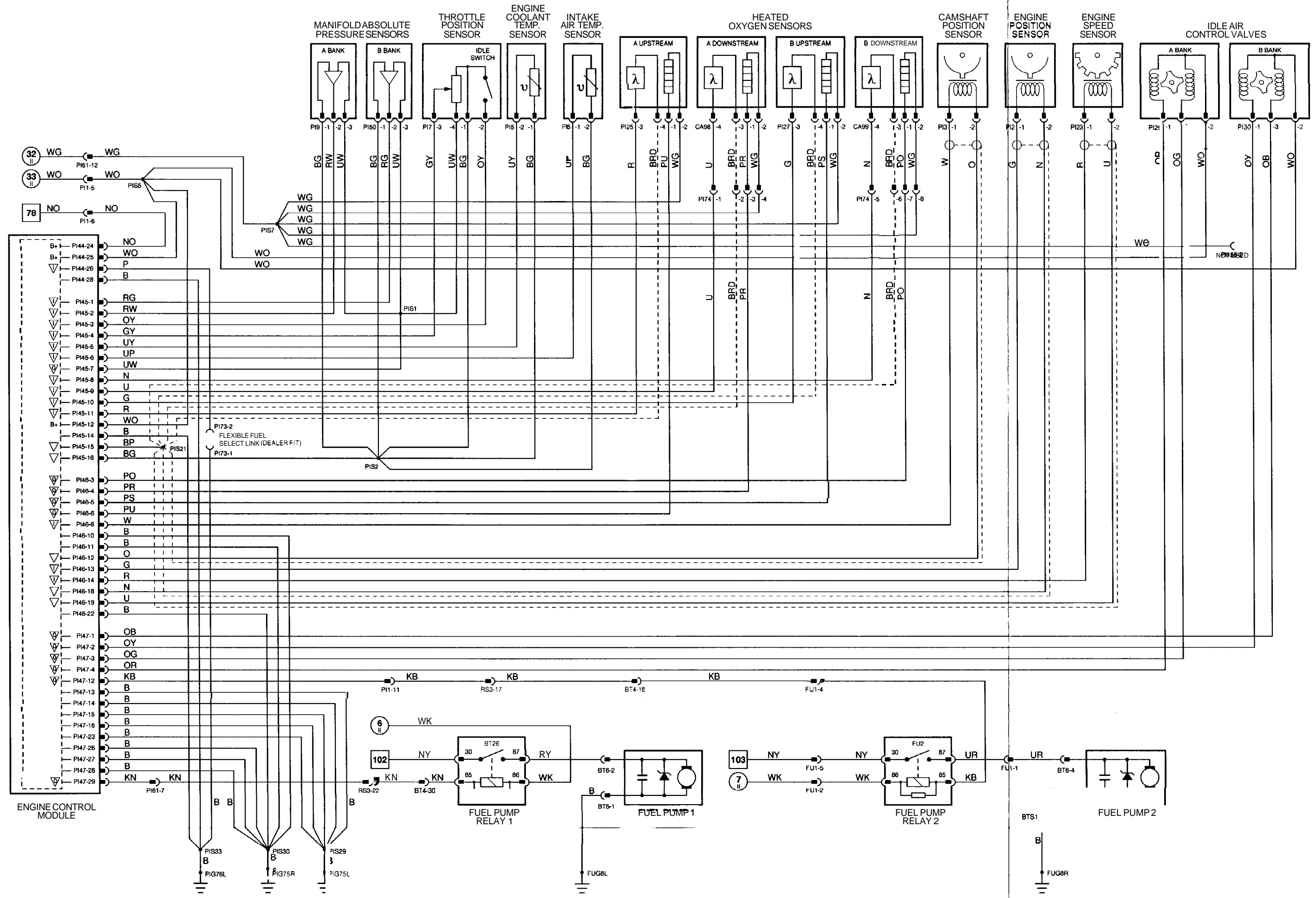

## CONTROL MODULE PIN OUT INFORMATION

### ENGINE CONTROL MODULE (V12)

Pin	Description	Active	Inactive
<b>V</b> P1U-1	FUEL USED	GROUND PULSE, 10 Hz @ IDLE	
<b>O</b> P144-2	CHECK ENGINE MIL	GROUND	B+
<b>O</b> P1M-3	ENGINE TORQUE SIGNAL	11.5 V @ IDLE, DECREASING WITH TORQUE INCREASE	
<b>O</b> P1U-4	THROTTLE POSITION	1.4 V @ IDLE, 9 V @ FULL THROTTLE	
<b>O</b> P1U-5	LOAD INHIBIT SIGNAL	GROUND	B+
<b>I</b> P144-6	TORQUE REDUCTION	GROUND PULSE @ SHIFT	11.5 V @ IDLE
<b>I</b> P144-7	VEHICLE SPEED	GROUND	B+
<b>O</b> P144-10	ENGINE SPEED	5 V @ 1000 RPM = 45 Hz, 2000 RPM = 90 Hz	
<b>I</b> P144-12	ELECTRICAL LOAD HEATED WINDSHIELD, HEATED BACKLIGHT, OR BLOWERS ON HIGH SPEED	GROUND	B+
<b>I</b> P144-13	AIR CONDITIONING REQUEST	B+	GROUND
<b>D</b> P144-14	FUELING INHIBIT SIGNAL	ENCODED COMMUNICATIONS	
<b>I</b> P1U-18	PARK / NEUTRAL	GROUND	B+
<b>I</b> P144-21	FUEL LEVEL	B+	GROUND
<b>D</b> P1U-22	SERIAL COMMUNICATION INPUT		
<b>D</b> P144-23	SERIAL COMMUNICATION OUTPUT		
<b>I</b> P1U-26	FLEXIBLE FUEL SELECT LINK (DEALER FIT)	GROUND (FITTED)	B+
<b>I</b> P145-13	POWER STEERING PRESSURE SWITCH	GROUND	B+
<b>I</b> P146-7	CRANK SIGNAL	GROUND	B+
<b>O</b> P1@-16	AIR CONDITIONING CLUTCH RELAY	GROUND	B+
<b>O</b> P146-17	SECONDARY AIR INJECTION RELAY	GROUND	B+
<b>I</b> P146-20	IGNITION FAILURE - B BANK	B+	1.7 V
<b>I</b> P146-21	IGNITION FAILURE - A BANK	B+	1.7 V
<b>O</b> P147-5	FUEL INJECTORS 3 & 5 - B BANK	GROUND PULSE, 3.5 MS @ IDLE	
<b>O</b> P147-6	FUEL INJECTORS 2 & 4 - A BANK	GROUND PULSE, 3.5 MS @ IDLE	
<b>O</b> P147-7	FUEL INJECTORS 1 & 4 - B BANK	GROUND PULSE, 3.5 MS @ IDLE	
<b>O</b> P147-8	FUEL INJECTORS 3 & 6 - ABANK	GROUND PULSE, 3.5 MS @ IDLE	
<b>O</b> P147-9	FUEL INJECTORS 2 & 6 - B BANK	GROUND PULSE, 3.5 MS @ IDLE	
<b>O</b> P147-10	FUEL INJECTORS 1 & 5 - ABANK	GROUND PULSE, 3.5 MS @ IDLE	
<b>O</b> P147-11	SECONDARY AIR VACUUM SOLENOID VALVE	B+	GROUND
<b>O</b> P147-17	IGNITION MODULE NEGATIVE - 3B	GROUND PULSE, 1000 RPM = 15 Hz	
<b>O</b> P147-18	IGNITION MODULE NEGATIVE - 2B	GROUND PULSE, 1000 RPM = 15 Hz	
<b>O</b> P147-19	IGNITION MODULE NEGATIVE - 1B	GROUND PULSE, 1000 RPM = 15 Hz	
<b>O</b> P147-20	IGNITION MODULE NEGATIVE - 3A	GROUND PULSE, 1000 RPM = 15 Hz	
<b>O</b> P147-21	IGNITION MODULE NEGATIVE - 2A	GROUND PULSE, 1000 RPM = 15 Hz	
<b>O</b> P147-22	IGNITION MODULE NEGATIVE - 1A	GROUND PULSE, 1000 RPM = 15 Hz	
<b>O</b> P147-33	EVAP VALVE - B BANK	B+	GROUND
<b>O</b> P147-34	EVAP VALVE - A BANK	B+	GROUND

## Fig. 04.9

### COMPONENTS

Component	Connector / Type / Color	Location / Access
DIODE (P181) - AIRP SOLENOID SUPPRESSION ENGINE CONTROL MODULE (V12)	P181 / DIODE / BLACK P144 128-WAY MULTILOCK III LC / SLATE P145 / 16-WAY MULTILOCK 040 / SLATE P146 / 22-WAY MULTILOCK 040 / SLATE P147 / 34-WAY MULTILOCK 040 / SLATE	EMS HARNESS / SECONDARY AIR INJECTION PUMP RH 'A' POST / 'A' POST TRIM
EVAPORATIVE EMISSION CONTROL VALVE (V12 A BANK) EVAPORATIVE EMISSION CONTROL VALVE (V12 B BANK) FUEL INJECTOR (V12 A BANK 1) FUEL INJECTOR (V12 A BANK 2) FUEL INJECTOR (V12 A BANK 3) FUEL INJECTOR (V12 A BANK 4) FUEL INJECTOR (V12 A BANK 5) FUEL INJECTOR (V12 A BANK 6) FUEL INJECTOR (V12 B BANK 1) FUEL INJECTOR (V12 B BANK 2) FUEL INJECTOR (V12 B BANK 3) FUEL INJECTOR (V12 B BANK 4) FUEL INJECTOR (V12 B BANK 5) FUEL INJECTOR (V12 B BANK 6) IGNITION COIL (V12 A BANK) IGNITION COIL (V12 B BANK) IGNITION MODULE (V12 A BANK) IGNITION MODULE (V12 B BANK) POWER STEERING PRESSURE SWITCH SECONDARY AIR INJECTION CLUTCH SECONDARY AIR INJECTION SWITCHING VALVE	P118 / 2-WAY JUNIOR TIMER / BLACK P119 / 2-WAY JUNIOR TIMER / BLACK P132 / 2-WAY JUNIOR TIMER / SLATE P133 / 2-WAY JUNIOR TIMER / SLATE P134 / 2-WAY JUNIOR TIMER / SLATE P135 / 2-WAY JUNIOR TIMER / SLATE P136 12-WAY JUNIOR TIMER / SLATE P137 / 2-WAY JUNIOR TIMER / SLATE P138 / 2-WAY JUNIOR TIMER / SLATE P139 12-WAY JUNIOR TIMER / SLATE P140 12-WAY JUNIOR TIMER / SLATE P141 / 2-WAY JUNIOR TIMER / SLATE P142 / 2-WAY JUNIOR TIMER / SLATE P143 / 2-WAY JUNIOR TIMER / SLATE P112 14-WAY SUB-MINIATURE / BLACK P113 / 1-WAY SUB-MINIATURE / BLACK P110 / 8-WAY SUMITOMO 90 / SLATE P111 18-WAY SUMITOMO 90 / SLATE P168 / 2-WAY JUNIOR TIMER / BLACK P121 (FLY LEAD) 12-WAY ECONOSEAL III LC / BLACK P122 / 2-WAY DENSO / BLUE	BELOW LH FRONT RELAYS BELOW LH FRONT RELAYS FUEL RAIL, INTAKE MANIFOLD FUEL RAIL, INTAKE MANIFOLD FUEL RAIL, INTAKE MANIFOLD FUEL RAIL, INTAKE MANIFOLD FUEL RAIL, INTAKE MANIFOLD FUEL RAIL, INTAKE MANIFOLD FUEL RAIL, INTAKE MANIFOLD FUEL RAIL, INTAKE MANIFOLD FUEL RAIL, INTAKE MANIFOLD FUEL RAIL, INTAKE MANIFOLD FUEL RAIL, INTAKE MANIFOLD ENGINE VEE ENGINE VEE ENGINE BAY, RH INNER FENDER ENGINE BAY, RH INNER FENDER POWER STEERING PUMP SECONDARY AIR INJECTION PUMP A BANK INTAKE MANIFOLD REAR

### RELAYS

Relay	Color / Stripe	Connector / Color	Location / Access
FUEL INJECTOR RELAY (MAIN RELAY) (V12)	BLACK	P120 / BLACK	RH ENGINE BAY RELAYS
SECONDARY AIR INJECTION RELAY (V12)	BLACK / WHITE	P152 / BLACK	RH ENGINE BAY RELAYS
IGNITION COIL RELAY (V12)	BLACK	P153 / BLACK	RH ENGINE BAY RELAYS

### HARNESSTO-HARNESSTO CONNECTORS

Connector	Type / Color	Location / Access
P11	13-WAY ECONOSEAL III LC / WHITE	RH AIR CLEANER
P159	13-WAY ECONOSEAL III LC / BLACK	LH AIR CLEANER
P161	13-WAY ECONOSEAL III LC / BLACK	RH AIR CLEANER
P163	20-WAY MULTILOCK 040 / BLACK	RH 'A' POST / 'A' POST TRIM
P173	2-WAY MULTILOCK 070 / YELLOW	RH 'A' POST / 'A' POST TRIM

### GROUNDS

Ground	Location / Type
PIG75L	RH 'A' POST GROUND STUD
PIG75R	RH 'A' POST GROUND STUD
PIG76L	RH BULKHEAD GROUND STUD
PIG77R	RIGHT FORWARD EMS GROUND STUD

### CONTROL MODULE PIN OUT INFORMATION (FOLD OUT PAGE)



The following symbols are used to represent values for Control Module Pin Out data:

<b>I</b> Input	<b>B+</b> Battery voltage
<b>O</b> Output	<b>V</b> Voltage (DC)
<b>SG</b> Signal Ground	<b>Hz</b> Frequency
<b>D</b> Serial and encoded communications	<b>KHz</b> Frequency x 1000
	<b>MS</b> Milliseconds
	<b>MV</b> Millivolts

CAUTION: The information on this data page is furnished to aid the user in understanding circuit operation. THIS INFORMATION SHOULD BE USED FOR REFERENCE ONLY.

NOTE: The values listed are approximately those that can be expected at the control module connector pins with all circuit connections made and all components connected and fitted. "Active" means a load is applied or a switch is ON; "Inactive" means a load is not applied or a switch is OFF.

REFER TO THE FRONT OF THE BOOK FOR ILLUSTRATIONS DETAILING THE LOCATION AND IDENTIFICATION OF COMPONENTS, RELAYS, CONNECTORS, HARNESSES, GROUNDS, VEHICLE ELECTRICAL MODULE AND CONTROL MODULE PINS.

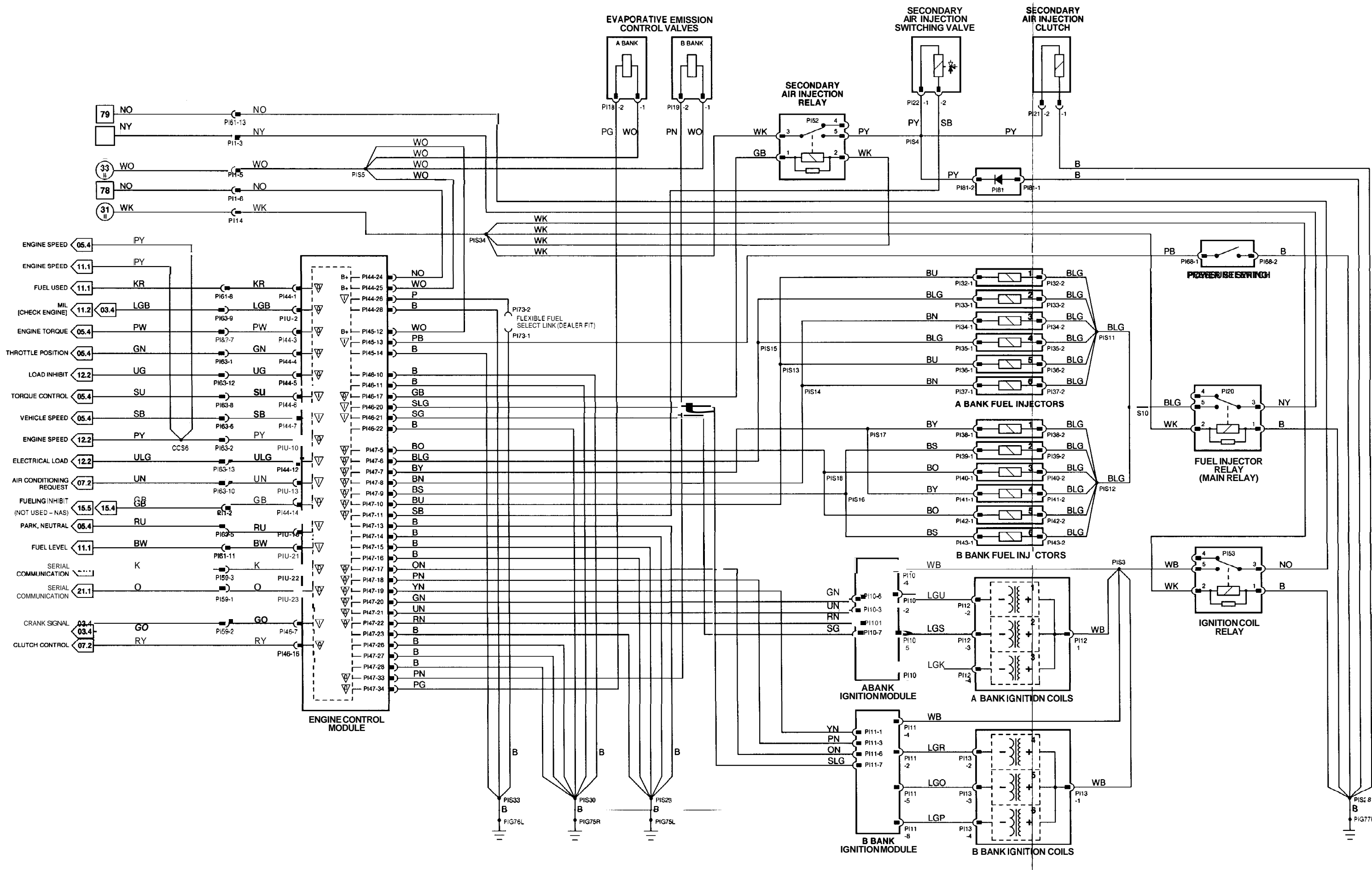

## CONTROL MODULE PIN OUT INFORMATION

### ENGINE CONTROL MODULE (V12)

Pin	Description	Active	Inactive
I P144-26	FLEXIBLE FUEL SELECT LINK (DEALER FIT)	GROUND (FITTED)	B+
I P18-1	MAP SENSOR FEEDBACK - B BANK	1.7 V @ IDLE, INCREASING WITH MANIFOLD ABSOLUTE PRESSURE	
I P145-2	MAP SENSOR FEEDBACK - A BANK	1.7 V @ IDLE, INCREASING WITH MANIFOLD ABSOLUTE PRESSURE	
I P145-3	IDLE SWITCH	GROUND	B+
I P145-4	THROTTLE POSITION SENSOR FEEDBACK VOLTAGE	0.58 V @ IDLE, 4.75 V @ FULL THROTTLE	
I P145-5	COOLANT TEMPERATURE SENSOR	0.41 V @ 90° C, INCREASING WITH TEMPERATURE	
I P145-6	INTAKE AIR TEMPERATURE SENSOR	0.59 V @ 10° C, INCREASING WITH TEMPERATURE	
O P145-7	COMMON SENSOR REFERENCE VOLTAGE	5 v	5 v
I P145-10	UPSTREAM HO2S FEEDBACK - B BANK	0.1 - 0.8 V (SWING)	
I P145-11	UPSTREAM HO2S FEEDBACK - A BANK	0.1 - 0.8 V (SWING)	
SG P145-15	COMMON SENSOR SHIELD GROUND	GROUND	GROUND
SG P145-16	COMMON SENSOR REFERENCE GROUND	GROUND	GROUND
O P146-5	UPSTREAM HO2S HEATER GROUND - B BANK	GROUND	B+
O P146-6	UPSTREAM HO2S HEATER GROUND - A BANK	GROUND	B+
I P146-8	CAMSHAFT POSITION SENSOR	GROUND PULSE @ 1000 RPM = 8 Hz, 2000 RPM = 16 Hz	
SG P146-12	CAMSHAFT POSITION SENSOR	GROUND	GROUND
I P146-13	ENGINE POSITION SENSOR	GROUND PULSE @ 1000 RPM = 15 Hz, 2000 RPM = 30 Hz	
I P146-14	ENGINE SPEED SENSOR	GROUND PULSE @ 1000 RPM = 175 Hz, 2000 RPM = 350 Hz	
SG P146-18	ENGINE POSITION SENSOR	GROUND	GROUND
SG P146-19	ENGINE SPEED SENSOR	GROUND	GROUND
O P147-1	IDLE AIR CONTROL VALVE CLOSE - B BANK	4.8 V @ IDLE	B+
O P147-2	IDLE AIR CONTROL VALVE OPEN - B BANK	9.8 V @ IDLE	B+
O P147-3	IDLE AIR CONTROL VALVE CLOSE - A BANK	4.8 V @ IDLE	
O P147-4	IDLE AIR CONTROL VALVE OPEN - A BANK	9.8 V @ IDLE	
O P147-12	FUEL PUMP RELAY 2	GROUND	B+
O P147-29	FUEL PUMP RELAY 1	GROUND	B+

The following symbols are used to represent values for Control Module Pin Out data:

I	Input	B+	Battery voltage
O	output	V	Voltage (DC)
SG	Signal Ground	Hz	Frequency
D	Serial and encoded communications	KHz	Frequency x 1000
		MS	Milliseconds
		MV	Millivolts

**CAUTION:** The information on this data page is furnished to aid the user in understanding circuit operation. THIS INFORMATION SHOULD BE USED FOR REFERENCE ONLY.

**NOTE:** The values listed are approximately those that can be expected at the control module connector pins with all circuit connections made and all components connected and fitted. "Active" means a load is applied or a switch is ON; "Inactive" means a load is not applied or a switch is OFF.

## Fig. 04.10

### COMPONENTS

Component	Connector / Type / Color	Location / Access
CAMSHAFT POSITION SENSOR (V12)	P13 (FLY LEAD) 12-WAY ECONOSEAL III LC / BLACK	A BANK CAMSHAFT COVER
CATALYST SWITCHING MODULE	P1155 / 8-WAY MULTILOCK 070 / WHITE	RH 'A' POST, ECM / 'A' POST TRIM
CATALYST THERMOCOUPLES	P1156 (FLY LEAD) 14-WAY ECONOSEAL III LC / BLACK	REAR OF ENGINE
ENGINE CONTROL MODULE (V12)	P144 / 28-WAY MULTILOCK 0401 SLATE P145 / 16-WAY MULTILOCK 040 / SLATE P146 / 22-WAY MULTILOCK 040 / SLATE P147 / 34-WAY MULTILOCK 040 / SLATE	RH 'A' POST / 'A' POST TRIM
ENGINE COOLANT TEMPERATURE SENSOR (V12)	P15 / 2-WAY ECONOSEAL J / SLATE	B BANK THERMOSTAT HOUSING
ENGINE POSITION SENSOR	P12 (FLY LEAD) 12-WAY ECONOSEAL III LC / BLACK	ENGINE TIMING COVER
ENGINE SPEED SENSOR	P123 (FLY LEAD) 12-WAY ECONOSEAL III LC / BLACK	ENGINE ME, REAR
FUEL PUMP (1)	BT6 (FLY LEAD) / 4-WAY SUMITOMO 90 / WHITE	FUEL TANK / FUEL TANK TRIM
FUEL PUMP (2)	BT8 (FLY LEAD) / 4-WAY SUMITOMO 90 / WHITE	FUEL TANK / FUEL TANK TRIM
HEATED OXYGEN SENSOR (V12 A BANK)	P125 (FLY LEAD) / 4-WAY SUMITOMO 90 / SLATE	A BANK EXHAUST, DOWNSTREAM OF PRIMARY CATALYST
HEATED OXYGEN SENSOR (V12 B BANK)	P127 (FLY LEAD) 14-WAY SUMITOMO 901 SLATE	B BANK EXHAUST, DOWNSTREAM OF PRIMARY CATALYST
IDLE AIR CONTROL VALVE (V12 A BANK)	P129 / 3-WAY SUMITOMO 901 SLATE	A BANK THROTTLE BODY
IDLE AIR CONTROL VALVE (V12 B BANK)	P130 / 3-WAY SUMITOMO 90 / SLATE	B BANK THROTTLE BODY
INTAKE AIR TEMPERATURE SENSOR (V12)	P16 / 2-WAY JUNIOR TIMER / BLACK	A BANK AIR INTAKE
MANIFOLD ABSOLUTE PRESSURE SENSOR (V12 A BANK)	P19 / 3-WAY SUMITOMO 90 / BLACK	A BANK INTAKE MANIFOLD, REAR
MANIFOLD ABSOLUTE PRESSURE SENSOR (V12 B BANK)	P150 / 3-WAY SUMITOMO 90 / BLACK	B BANK INTAKE MANIFOLD, REAR
THROTTLE POSITION SENSOR (V12)	P17 / 4-WAY ECONOSEAL J / BLACK	THROTTLE TURNTABLE

### RELAYS

Relay	Color / Stripe	Connector / Color	Location / Access
FUEL PUMP RELAY III	BLACK / VIOLET	BT26 / GREEN	TRUNK ELECTRICAL CARRIER
FUEL PUMP RELAY (2)	BLUE	FUY YELLOW	BATTERY COVER

### HARNESS-TO-HARNESS CONNECTORS

Connector	Type / Color	Location / Access
BT4	THROUGH-PANEL 148 MICRO / 6 / BLACK	PARCEL SHELF / FUEL TANK TRIM
FU1	6-WAY MULTILOCK 070 / WHITE	FUEL TANK TRIM / BATTERY COVER
P11	13-WAY ECONOSEAL III LC / WHITE	RH AIR CLEANER
P161	13-WAY ECONOSEAL III LC / BLACK	RH AIR CLEANER
P173	2-WAY MULTILOCK 070 / YELLOW	RH 'A' POST / 'A' POST TRIM
RS3	THROUGH-PANEL 148 MICRO / 6 / BROWN	RH 'A' POST / 'A' POST PANEL

### GROUNDS

Ground	Location / Type
FUG8L	FRONT TRUNK GROUND STUD
FUG8R	FRONT TRUNK GROUND STUD
PIG75L	RH 'A' POST GROUND STUD
PIG75R	RH 'A' POST GROUND STUD
PIG76L	RH BULKHEAD GROUND STUD
PIG76R	RH BULKHEAD GROUND STUD

### CONTROL MODULE PIN OUT INFORMATION (FOLD OUT PAGE)



REFER TO THE FRONT OF THE BOOK FOR ILLUSTRATIONS DETAILING THE LOCATION AND IDENTIFICATION OF COMPONENTS, RELAYS, CONNECTORS, HARNESSES, GROUNDS, VEHICLE CONTROL MODULES AND CONTROL MODULE PINS

DATE OF ISSUE: APRIL 1995



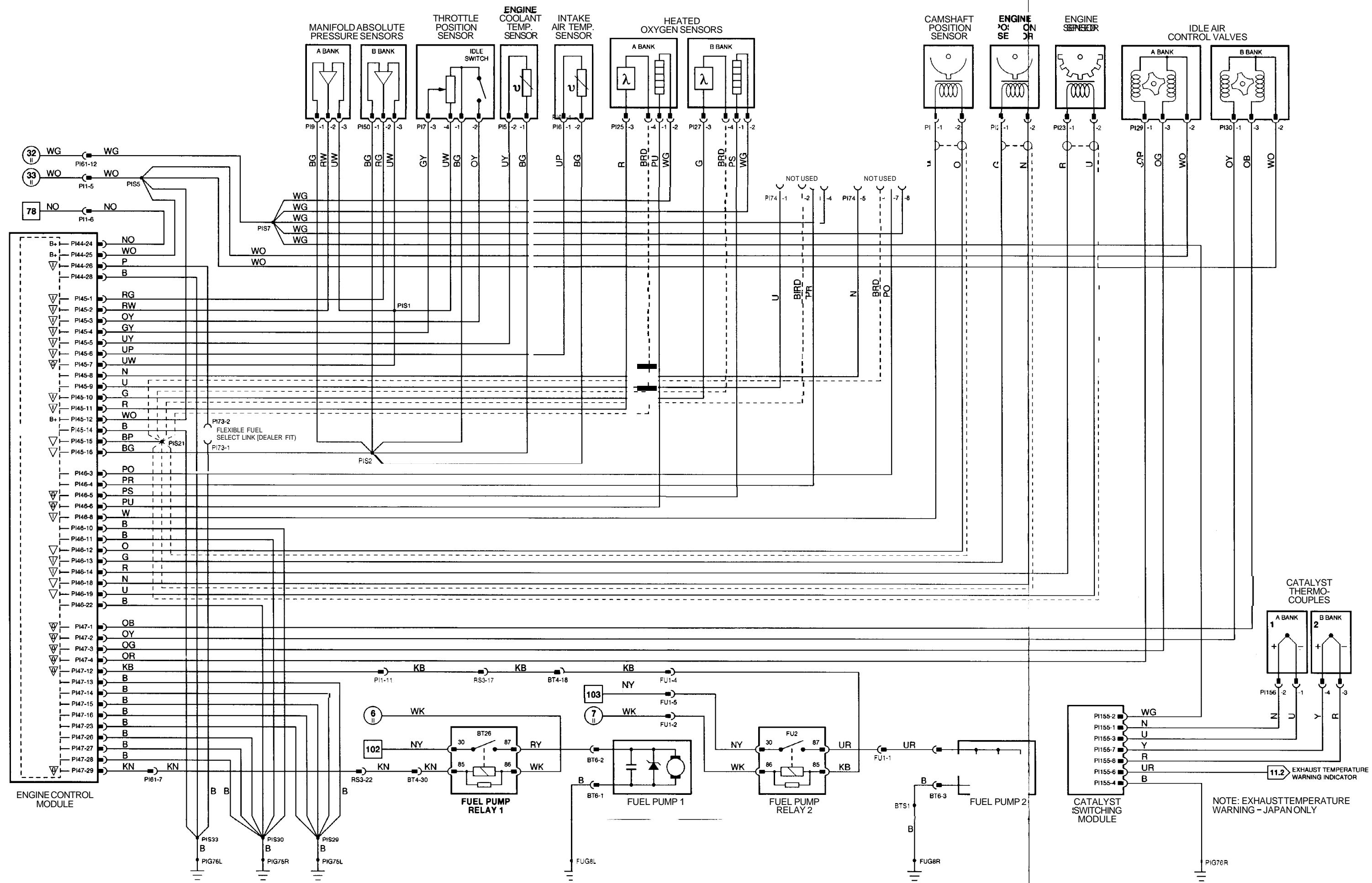

## CONTROL MODULE PIN OUT INFORMATION

### ENGINE CONTROL MODULE (V12)

Pin	Description	Active	Inactive
O P144-1	FUEL USED	GROUND PULSE, 10 Hz @ IDLE	
O P144-2	CHECK ENGINE MIL	GROUND	B+
O PIU-3	ENGINE TORQUE SIGNAL	11.5 V @ IDLE, DECREASING WITH TORQUE INCREASE	
O PIU-4	THROTTLE POSITION	1.4 V @ IDLE, 9 V @ FULL THROTTLE	
O P144-5	LOAD INHIBIT SIGNAL	GROUND	B+
I PIU-6	TORQUE REDUCTION	GROUND PULSE @ SHIFT	11.5 V @ IDLE
I PIU-7	VEHICLE SPEED	GROUND	B+
O PIU-10	ENGINE SPEED	5 V @ 1000 RPM = 45 Hz, 2000 RPM = 90 Hz	
I PIU-12	ELECTRICAL LOAD HEATED WINDSHIELD, HEATED BACKLIGHT, OR BLOWERS ON HIGH SPEED	GROUND	B+
I P144-13	AIR CONDITIONING REQUEST	B+	GROUND
D P144-14	FUELING INHIBIT SIGNAL	ENCODED COMMUNICATIONS	
I P144-18	PARK / NEUTRAL	GROUND	B+
I PIU-21	FUEL LEVEL	B+	GROUND
D PIU-22	SERIAL COMMUNICATION INPUT		
D PIU-23	SERIAL COMMUNICATION OUTPUT		
I PIU-26	FLEXIBLE FUEL SELECT LINK (DEALER FIT)	GROUND (FITTED)	B+
I P145-13	POWER STEERING PRESSURE SWITCH	GROUND	B+
I P146-7	CRANK SIGNAL	GROUND	B+
O P146-16	AIR CONDITIONING CLUTCH RELAY	GROUND	B+
O P146-17	SECONDARY AIR INJECTION RELAY	GROUND	B+
I P146-20	IGNITION FAILURE - B BANK	B+	1.7 V
I P146-21	IGNITION FAILURE - A BANK	B+	1.7 V
O P147-5	FUEL INJECTORS 3 & 5 - B BANK	GROUND PULSE, 3.5 MS @ IDLE	
O P147-6	FUEL INJECTORS 2 & 4 - A BANK	GROUND PULSE, 3.5 MS @ IDLE	
O P147-7	FUEL INJECTORS 1 & 4 - B BANK	GROUND PULSE, 3.5 MS @ IDLE	
O P147-8	FUEL INJECTORS 3 & 6 - A BANK	GROUND PULSE, 3.5 MS @ IDLE	
O P147-9	FUEL INJECTORS 2 & 6 - B BANK	GROUND PULSE, 3.5 MS @ IDLE	
O P147-10	FUEL INJECTORS 1 & 5 - A BANK	GROUND PULSE, 3.5 MS @ IDLE	
O P147-11	SECONDARY AIR VACUUM SOLENOID VALVE	B+	GROUND
O PY7-17	IGNITION MODULE NEGATIVE - 3B	GROUND PULSE, 1000 RPM = 15 Hz	
O P147-18	IGNITION MODULE NEGATIVE - 2B	GROUND PULSE, 1000 RPM = 15 Hz	
O P147-19	IGNITION MODULE NEGATIVE - 1B	GROUND PULSE, 1000 RPM = 15 Hz	
O P147-20	IGNITION MODULE NEGATIVE - 3A	GROUND PULSE, 1000 RPM = 15 Hz	
O P147-21	IGNITION MODULE NEGATIVE - 2A	GROUND PULSE, 1000 RPM = 15 Hz	
O P147-22	IGNITION MODULE NEGATIVE - 1A	GROUND PULSE, 1000 RPM = 15 Hz	
O P147-33	EVAP VALVE - B BANK	B+	GROUND
O P147-34	EVAP VALVE - A BANK	B+	GROUND

The following symbols are used to represent values for Control Module Pin Out data:

<b>I</b> Input	<b>B+</b> Battery voltage
<b>O</b> output	<b>V</b> Voltage (DC)
<b>SG</b> Signal Ground	<b>Hz</b> Frequency
<b>D</b> Serial and encoded communications	<b>KHz</b> Frequency x 1000
	<b>MS</b> Milliseconds
	<b>MV</b> Millivolts

**CAUTION:** The information on this data page is furnished to aid the user in understanding circuit operation. THIS INFORMATION SHOULD BE USED FOR REFERENCE ONLY.

**NOTE:** The values listed are approximately those that can be expected at the control module connector pins with all circuit connections made and all components connected and fitted. "Active" means a load is applied or a switch is ON; "Inactive" means a load is not applied or a switch is OFF.

## Fig. 04.11

### COMPONENTS

Component	Connector / Type / Color	Location / Access
DIODE (PI81) - AIRP SOLENOID SUPPRESSION ENGINE CONTROL MODULE (V12)	PI81 / DIODE BLACK PI44 / 28-WAY MULTILOCK MO / SLATE PI45 / 16-WAY MULTILOCK WO / SLATE PI46 / 22-WAY MULTILOCK 040 / SLATE PI47 / 34-WAY MULTILOCK 040 / SLATE	EMSHARNES / SECONDARY AIR INJECTION PUMP RH 'A' POST / 'A' POST TRIM
EVAPORATIVE EMISSION CONTROL VALVE (V12 A BANK) EVAPORATIVE EMISSION CONTROL VALVE (V12 B BANK) FUEL INJECTOR (V12 A BANK 1) FUEL INJECTOR (V12 A BANK 2) FUEL INJECTOR (V12 A BANK 3) FUEL INJECTOR (V12 A BANK 4) FUEL INJECTOR (V12 A BANK 5) FUEL INJECTOR (V12 A BANK 6) FUEL INJECTOR (V12 B BANK 1) FUEL INJECTOR (V12 B BANK 2) FUEL INJECTOR (V12 B BANK 3) FUEL INJECTOR (V12 B BANK 4) FUEL INJECTOR (V12 B BANK 5) FUEL INJECTOR (V12 B BANK 6) IGNITION COIL (V12 A BANK) IGNITION COIL (V12 B BANK) IGNITION MODULE (V12 A BANK) IGNITION MODULE (V12 B BANK) POWER STEERING PRESSURE SWITCH SECONDARY AIR INJECTION CLUTCH SECONDARY AIR INJECTION SWITCHING VALVE	PI18 12-WAY JUNIOR TIMER / BLACK PI19 12-WAY JUNIOR TIMER / BLACK PI32 12-WAY JUNIOR TIMER / SLATE PI33 / 2-WAY JUNIOR TIMER / SLATE PI34 / 2-WAY JUNIOR TIMER / SLATE PI35 / 2-WAY JUNIOR TIMER / SLATE PI36 / 2-WAY JUNIOR TIMER / SLATE PI37 12-WAY JUNIOR TIMER / SLATE PI38 12-WAY JUNIOR TIMER / SLATE PI39 12-WAY JUNIOR TIMER / SLATE PI40 / 2-WAY JUNIOR TIMER / SLATE PI41 12-WAY JUNIOR TIMER / SLATE PI42 12-WAY JUNIOR TIMER / SLATE PI43 / 2-WAY JUNIOR TIMER / SLATE PI12 / 4-WAY SUB-MINIATURE BLACK PI13 / 4-WAY SUB-MINIATURE BLACK PI10 / 8-WAY SUMITOMO 90 / SLATE PI11 / 8-WAY SUMITOMO 90 / SLATE PI68 / 2-WAY JUNIOR TIMER / BLACK PI21 (FLY LEAD) / 2-WAY ECONOSEAL III LC / BLACK PI22 / 2-WAY DENSO BLUE	BELOW LH FRONT RELAYS BELOW LH FRONT RELAYS FUEL RAIL, INTAKE MANIFOLD FUEL RAIL, INTAKE MANIFOLD FUEL RAIL, INTAKE MANIFOLD FUEL RAIL, INTAKE MANIFOLD FUEL RAIL, INTAKE MANIFOLD FUEL RAIL, INTAKE MANIFOLD FUEL RAIL, INTAKE MANIFOLD FUEL RAIL, INTAKE MANIFOLD FUEL RAIL, INTAKE MANIFOLD FUEL RAIL, INTAKE MANIFOLD FUEL RAIL, INTAKE MANIFOLD ENGINE VEE ENGINE VEE ENGINE BAY, RH INNER FENDER ENGINE BAY, RH INNER FENDER POWER STEERING PUMP SECONDARY AIR INJECTION PUMP A BANK INTAKE MANIFOLD REAR

### RELAYS

Relay	Color / Stripe	Connector / Color	Location / Access
FUEL INJECTOR RELAY (MAIN RELAY) (V12)	BLACK	PI20 / BLACK	RH ENGINE BAY RELAYS
IGNITION COIL RELAY (V12)	BLACK	PI53 / BLACK	RH ENGINE BAY RELAYS
SECONDARY AIR INJECTION RELAY (V12)	BLACK / WHITE	PI52 / BLACK	RH ENGINE BAY RELAYS

### HARNESSTO-HARNESSTO CONNECTORS

Connector	Type / Color	Location / Access
PI1	13-WAY ECONOSEAL III LC / WHITE	RH AIR CLEANER
PI59	13-WAY ECONOSEAL III LC / BLACK	LH AIR CLEANER
PI61	13-WAY ECONOSEAL III LC / BLACK	RH AIR CLEANER
PI63	20-WAY MULTILOCK 040 / BLACK	RH 'A' POST / 'A' POST TRIM
PI73	2-WAY MULTILOCK 070 / YELLOW	RH 'A' POST / 'A' POST TRIM

### GROUNDS

Ground	Location / Type
PIG75L	RH 'A' POST GROUND STUD
PIG75R	RH 'A' POST GROUND STUD
PIG76L	RH BULKHEAD GROUND STUD
PIG77R	RIGHT FORWARD EMS GROUND STUD

### CONTROL MODULE PIN OUT INFORMATION (FOLD OUT PAGE)



REFER TO THE FRONT OF THE BOOK FOR ILLUSTRATIONS OF THE LOCATION AND IDENTIFICATION OF COMPONENTS AND CONNECTORS, HARNESSES, GROUNDS, VEHICLE CONTROL MODULES AND CONTROL MODULE PINS

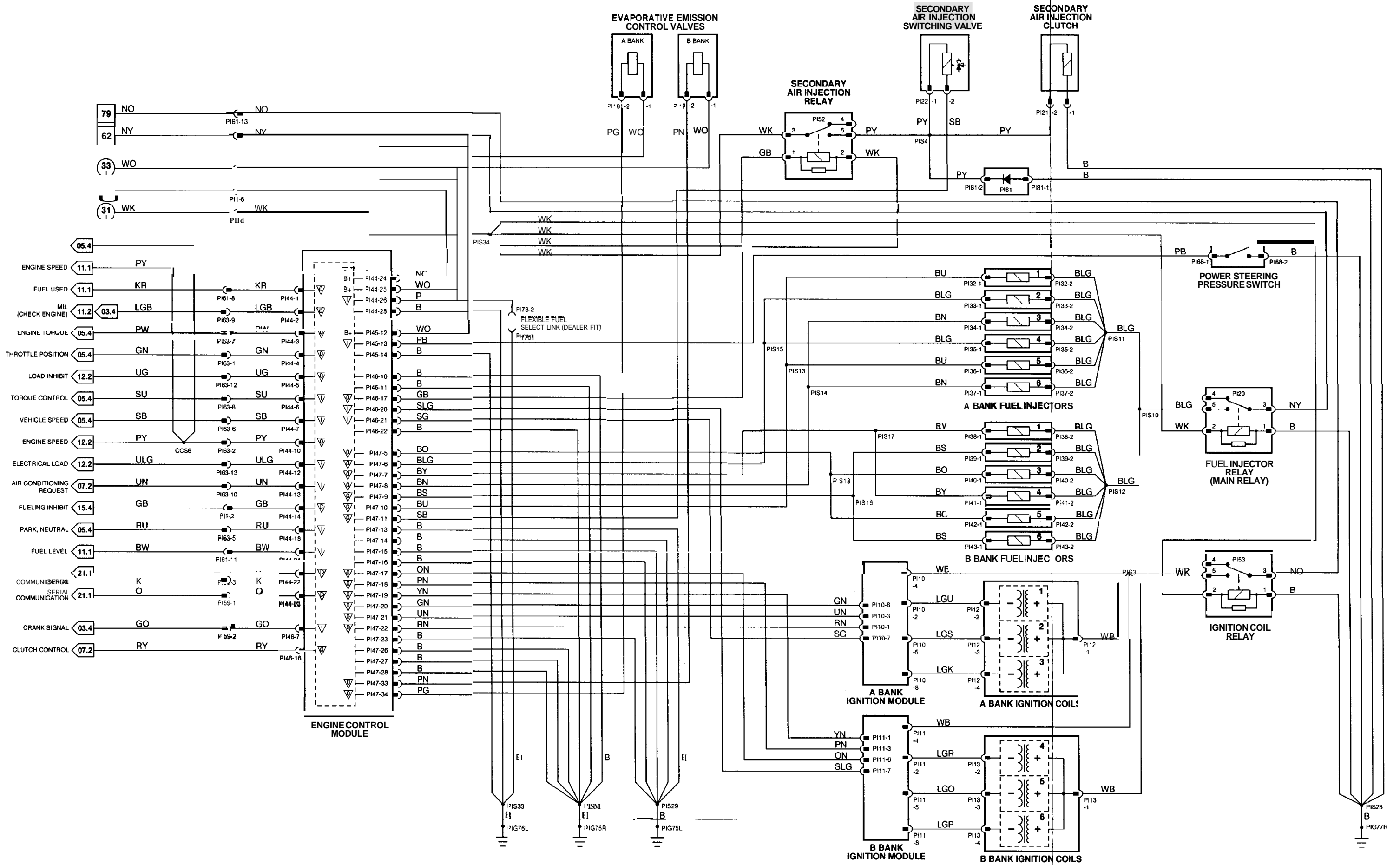

CONTROL MODULE PIN OUT INFORMATION

DECODER MODULE

Pin	Description	Active	Inactive
o CC13-1	GEAR POSITION 3	GROUND	5 v
o CC13-2	GEAR POSITION 2	GROUND	5 v
o CC13-3	GEAR POSITION 'R'	GROUND	5 v
o CC13-4	GEAR POSITION 'D'	GROUND	5 v
I CC13-11	GEAR POSITION 'Y'	GROUND = R, N, D, 3	2 V = P, 2
I CC13-12	GEAR POSITION 'Z'	GROUND = D, 3, 2	2 V = P, R, N
I CC13-13	GEAR POSITION 'X'	GROUND = P, R, 3, 2	2 V = N, 0
o CC13-14	GEAR SELECTOR 'NEUTRAL' ILLUMINATION	GROUND = N	5 V = P, R, D, 3, 2
o CC13-15	GEAR SELECTOR 'PARK' ILLUMINATION	GROUND = P	5 V = R, N, D, 3, 2
o CC13-23	SPEED CONTROL INHIBIT	GROUND = D, 3, 2	B+ = P, R, N
o CC13-24	PARK, NEUTRAL OUTPUT	GROUND = P, N	B+ = R, D, 3, 2

TRANSMISSION CONTROL MODULE (AJ16 NA)

Pin	Description	Active	Inactive
I CC7-2	OUTPUT SHAFTSPEED SENSOR	1.51 V @ 10 MPH 116 KPH = 280 Hz 20 MPH (32 KPH) = 560 Hz	
I cc7-3	ENGINE SPEED SENSOR	5 V @ 1000 RPM = 45 Hz, 2000 RPM = 90 Hz	
I CC7-4	MODE SWITCH SELECTION	GROUND = NORMAL	B+ = SPORT
o cc7-5	SHIFT SOLENOID 1 (MV1)	GROUND = 2, 3	B+ = P, N, D, 1, 4
o CC7-6	PRESSURE REGULATOR	9.5V @ IDLE, DECREASING WITH PRESSURE INCREASE	
I CC7-14	POSITION CODE 'Y'	GROUND = R, N, 0, 3	2 V = P, 2
D CC7-15	SERIAL COMMUNICATION INPUT		
o CC7-16	TRANSMISSION MIL	GROUND	9.4 V
o CC7-19	PRESSURE REGULATOR / SHIFT SOLENOIDS SUPPLY	B+	B+
I CC7-21	ENGINE TORQUE	10.4 V = NO LOAD, DECREASING WITH ENGINE LOAD	
o cc7-24	SHIFT SOLENOID 2 (MV2)	GROUND = P, N, D, 2, 1	B+ = 3, 4
I CC7-29	TRACTION ACTIVE	GROUND PULSE	B+
o CC7-32	TORQUE REDUCTION REQUEST	GROUND PULSE @ SHIFT (7.8 V)	9.4 V @ IDLE
I cc7-33	POSITION CODE 'Z'	GROUND = D, 3, 2	B+ = P, R, N
SG CC7-38	OUTPUT SHAFT SPEED SENSOR	GROUND	GROUND
I CC7-41	KICK DOWN SWITCH	GROUND	B+
o CC7-42	LOCK UP SOLENOID (MV3)	GROUND	B+
SG CC7-44	FLUID TEMPERATURE SENSOR	1.31 V	
I CC7-46	FLUID TEMPERATURE SENSOR	1.16 V @ 90° C	
I cc7-47	THROTTLE POSITION SENSOR FEEDBACK VOLTAGE	1.31 V @ IDLE, 4.9 V = FULL THROTTLE	
o CC7-49	SPORT MODE INDICATOR	GROUND	B+
I CC7-50	POSITION CODE 'X'	GROUND = P, R, 3, 2	2 V = D, N
D CC7-51	SERIAL COMMUNICATION OUTPUT		

The following symbols are used to represent values for Control Module Pin Out data:

- I Input
- o output
- SG Signal Ground
- D Serial and encoded communications
- B+ Battery voltage
- V Voltage (DC)
- Hz Frequency
- KHz Frequency x 1000
- MS Milliseconds
- MV Millivolts

CAUTION: The information on this data page is furnished to aid the user in understanding circuit operation. THIS INFORMATION SHOULD BE USED FOR REFERENCE ONLY.

NOTE: The values listed are approximately those that can be expected at the control module connector pins with all circuit connections made and all components connected and fitted. "Active" means a load is applied or a switch is ON; "Inactive" means a load is not applied or a switch is OFF.

Fig. 05.1

COMPONENTS

Component	Connector / Type / Color	Location Access
DECODER MODULE	CC13 / 26-WAY MODU 4 / BLUE	CENTER CONSOLE
FLUID TEMPERATURE SENSOR	GB3 19-WAY HELLERMAN MUTSCH / BLACK	TRANSMISSION / SUMP
GEAR SELECTOR INDICATOR MODULE (AJ16 4.0L)	CC14 / 12-WAY MULTILOCK 040 / BLACK	'J' GATE / CENTER CONSOLE
KICKDOWN SWITCH	CA74 (RHD) (FLY LEAD) / 3-WAY MULTILOCK 070 / SLATE	UNDER ACCELERATOR
MODE SWITCH	CC54 (LHD) (FLY LEAD) / 13-WAY MULTILOCK 070 / SLATE	
OUTPUT SHAFT SENSOR	CC11 / 6-WAY MULTILOCK 040 / BLACK	CENTER CONSOLE
PRESSURE REGULATOR	GB3 / 9-WAY HELLERMAN DEUTSCH / BLACK	TRANSMISSION
ROTARY SWITCH	GB3 / 9-WAY HELLERMAN MUTSCH / BLACK	TRANSMISSION / SUMP
TRANSMISSION CONTROL MODULE (AJ16 NA)	GB1 (FLY LEAD) / 12-WAY MULTILOCK 070 / WHITE	'J' GATE / CENTER CONSOLE
TRANSMISSION SOLENOID VALVES	GB2 (FLY LEAD) / 12-WAY MULTILOCK 040 / BLACK	
	CC7 / 55-WAY BOSCH / BLACK	PASSENGERS UNDERSCUTTLE
	06319-WAY HELLERMAN DEUTSCH / BLACK	TRANSMISSION / SUMP

HARNESS-TO-HARNESS CONNECTORS

Connector	Type Color	Location / Access
CC5	20-WAY MULTILOCK 040 / GREEN	CENTER CONSOLE / CENTER CONSOLE GLOVE BOX
FC7	THROUGH-PANEL (48 MICRO / 6) / BLACK	PASSENGER'S UNDERSCUTTLE
PI63	20-WAY MULTILOCK 040 / BLACK	RH 'A' POST / 'A' POST TRIM

GROUNDS

Ground	Location Type
CCGBL	CENTER CONSOLE GROUND STUD
CCG8R	CENTER CONSOLE GROUND STUD
CCG51R	CENTER CONSOLE GROUND STUD

CONTROL MODULE PIN OUT INFORMATION (FOLD OUT PAGE)



REFER TO THE FRONT OF THE BOOK FOR ILLUSTRATIONS DETAILING THE LOCATION AND IDENTIFICATION OF COMPONENTS, RELAYS, CONNECTORS, HARNESSES, GROUNDS, VEHICLE CONTROL MODULES AND CONTROL MODULE PINS.

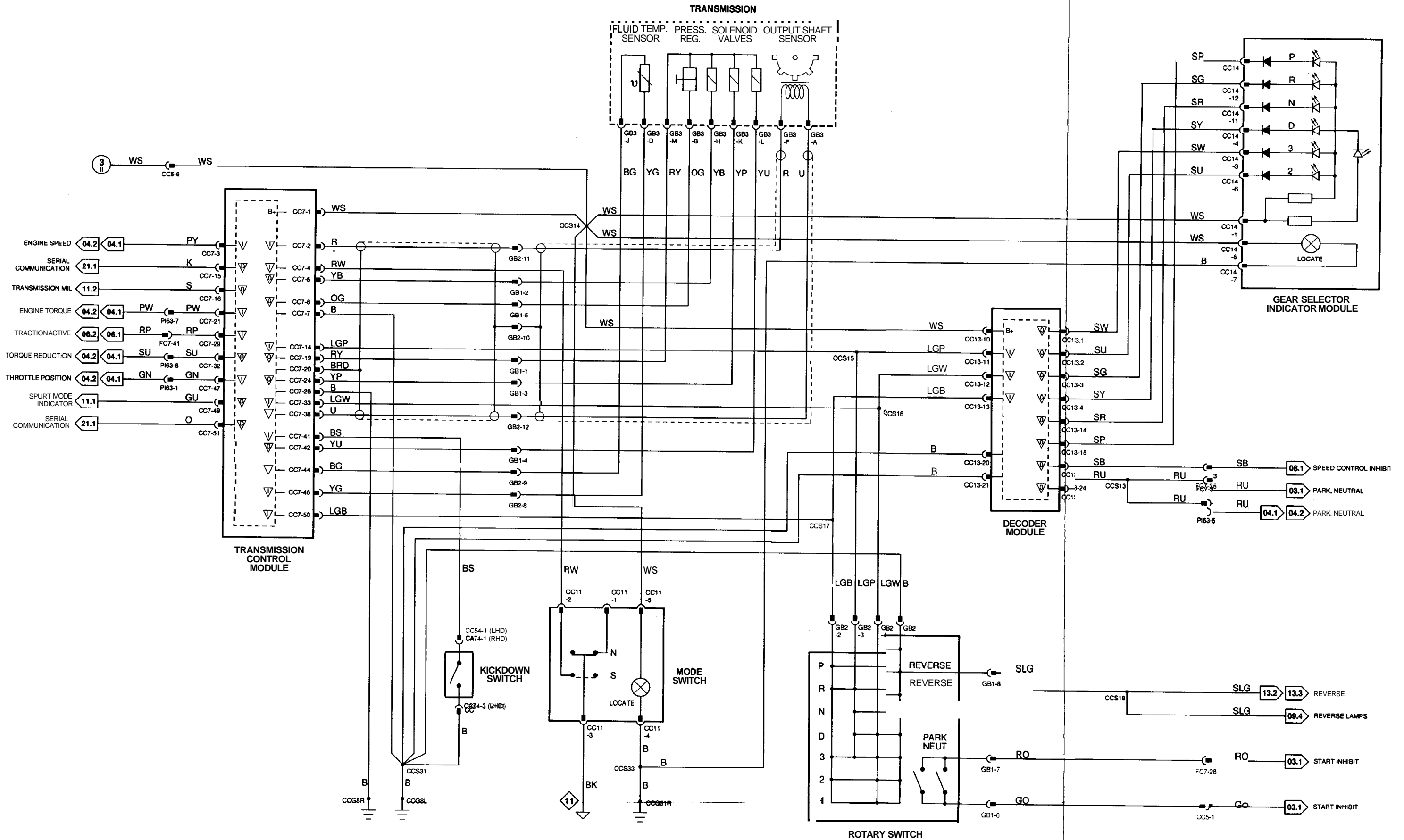

**CONTROL MODULE PIN OUT INFORMATION**

**TRANSMISSION CONTROL MODULE (AJ16 SC)**

Pin	Description	Active	Inactive
I CC48-3	PRESSURE SWITCH MANIFOLD	B+	B+
I CC48-4	PRESSURE SWITCH MANIFOLD	B+	B+
I CUB-5	MODE SWITCH	GROUND + SPORT	B+ + NORMAL
I CC48-6	CALIBRATION SELECT LINK (DEALER FIT)	GROUND + (FITTED)	B+
O CC48-7	TORQUE REDUCTION	GROUND PULSE @ SHIFT	11.5 V @ IDLE
I CC48-11	THROTTLE POSITION	1.4 V @ IDLE	9 V @ FULL THROTTLE
I CUB-12	ENGINE TORQUE	11.5 V @ IDLE, DECREASING WITH TORQUE INCREASE	
SG CC48-14	TRANSMISSION TEMPERATURE SENSOR	GROUND	GROUND
D CC48-16	SERIAL COMMUNICATION INPUT		
I CC48-22	PRESSURE SWITCH MANIFOLD	GROUND	GROUND
CC48-23	TRACTION ACTIVE	GROUND	B+
I CUB-24	KICK W W N SWITCH	GROUND	B+
I CC48-25	BRAKE SWITCH	GROUND	B+
I CC48-26	TRANSMISSION TEMPERATURE SENSOR	1.93 V @ 90° C	
I CC48-30	ENGINE SPEED SIGNAL	5 V @ 1000 RPM - 45 Hz, 2 w 0 RPM = 90 Hz	
SG CUB-36	OUTPUT SPEED SENSOR	GROUND	GROUND
SG CC48-37	INPUT SPEED SENSOR	GROUND	GROUND
O CC48-39	SHIFT SOLENOID 'A'	GROUND + 1,4	B+ + 2, 3
O CC48-40	TRANSMISSION MIL	GROUND	B+
O CC48-41	SPORT MODE INDICATOR LAMP	GROUND	B+
O CC48-42	TORQUE CONVERTER CLUTCH SOLENOID	GROUND	B+
O CUB-U	SHIFT SOLENOID 'B'	GROUND + 3,4	B+ + 1, 2
D CC48-45	SERIAL WMMUNICATION OUTPUT		
O CC48-49	VARIABLE FORCE MOTOR	1.3 V @ IDLE, DECREASING WITH PRESSURE INCREASE	
I CC48-50	INPUT SPEED SENSOR	GROUND @ 1000 RPM = 450 Hz, 2000 RPM = 9 WHz	
I CUB-51	OUTPUT SPEED SENSOR	GROUND @ 10 MPH (16 KPH) = 3 WHz, 20 MPH (32 KPH) = 600 Hz	
O CC48-52	VARIABLE FORCE MOTOR	7.7 V @ IDLE, DECREASING WITH PRESSURE INCREASE	

**COMPONENTS**

Component	Connector / Type Color	Location / Access
BRAKE SWITCH	CA72 / 4-WAY MULTILOCK 070 / WHITE	DRIVERS UNDERSCUTTLE
GEAR SELECTOR INDICATOR MODULE (AJ16 3.2L, 4.0L SC V12)	GB11 (FLY LEAD) / 112-WAY MULTILOCK 040 BLACK	'J' GATE CENTER CONSOLE
INPUT SPEED SENSOR	GB14 (FLY LEAD) / 3-WAY PACKARD / BLACK	TRANSMISSION, LH SIDE
KICKDOWN SWITCH	CA74 (RHD) (FLY LEAD) / 3-WAY MULTILOCK 070 / SLATE	UNDER ACCELERATOR
	CC54 (LHD) (FLY LEAD) / 3-WAY MULTILOCK 070 / SLATE	
LINEAR GEAR POSITION SWITCHES	CC21 120-WAY MULTILOCK 040 BLACK	'J' GATE CENTER CONSOLE
MODE SWITCH	CC11 16-WAY MULTILOCK 040 / BLACK	CENTER CONSOLE
OUTPUT SPEED SENSOR	GB13 (FLY LEAD) / 3-WAY PACKARD / BLACK	TRANSMISSION, LH SIDE
PRESSURE SWITCH MANIFOLD	GB12 / 12-WAY HELLERMAN DEUTSCH / BLACK	TRANSMISSION / SUMP
SHIFT SOLENOID (A)	GB12 112-WAY HELLERMAN DEUTSCH / BLACK	TRANSMISSION / SUMP
SHIFT SOLENOID (B)	GB12 112-WAY HELLERMAN DEUTSCH / BLACK	TRANSMISSION / SUMP
TORQUE CONVERTER CLUTCH SOLENOID	GB12 112-WAY HELLERMAN DEUTSCH / BLACK	TRANSMISSION / SUMP
TRANSMISSION CONTROL MODULE (V12 & AJ16 SC)	CUB / 55-WAY AMP 55 / BLACK	PASSENGER'S UNDERSCUTTLE
TRANSMISSION TEMPERATURE SENSOR	GB12 / 12-WAY HELLERMAN DEUTSCH / BLACK	TRANSMISSION / SUMP
VARIABLE FORCE MOTOR	GB12 112-WAY HELLERMAN DEUTSCH / BLACK	TRANSMISSION / SUMP

**HARNESS-TO-HARNESS CONNECTORS**

Connector	Type Color	Location Access
CC3	20-WAY MULTILOCK 040 / BLACK	CENTER CONSOLE / CENTER CONSOLE GLOVE BOX
CC4	14-WAY MULTILOCK 070 / WHITE	CENTER WNSOLE / CENTER CONSOLE GLOVE BOX
CC5	20-WAY MULTILOCK 040 / GREEN	CENTER CONSOLE / CENTER CONSOLE GLOVE BOX
CC38	2-WAY MULTILOCK 070 / YELLOW	PASSENGER'S UNDERSCUTTLE
FC7	THROUGH-PANEL (48 MICRO / 6) / BLACK	PASSENGER'S UNDERSCUTTLE
GB10	12-WAY MULTILOCK 040 / BLACK	CENTER CONSOLE / CENTER CONSOLE
GB15	8-WAY MULTILOCK 070 / WHITE	CENTER CONSOLE / CENTER CONSOLE
PI63	20-WAY MULTILOCK 040 / BLACK	RH 'A' POST / 'A' POST TRIM

**GROUNDS**

Ground	Location / Type
CAG30R	LH 'A' POST GROUND SCREW
CAGUR	RH HEELBOARD GROUND SCREW
CCG51R	CENTER CONSOLE GROUND STUD
CCG8L	CENTER CONSOLE GROUND STUD
CCG8R	CENTER CONSOLE GROUND STUD

**CONTROL MODULE PIN OUT INFORMATION (FOLD OUT PAGE)**



The following symbols are used to represent values for Control Module Pin Out data:

<b>I</b> Input	<b>B+</b> Battery voltage
<b>O</b> Output	<b>V</b> Voltage (DC)
<b>SG</b> Signal Ground	<b>Hz</b> Frequency
<b>D</b> Serial and encoded communications	<b>KHz</b> Frequency x 1000
	<b>MS</b> Milliseconds
	<b>MV</b> Millivolts

CAUTION: The information on this data page is furnished to aid the user in understanding circuit operation. THIS INFORMATION SHOULD BE USED FOR REFERENCE ONLY.

NOTE: The values listed are approximately those that can be expected at the control module connector pins with all circuit connections made and all components connected and fitted. "Active" means a load is applied or a switch is ON; "Inactive" means a load is not applied or a switch is OFF.

REFER TO THE FRONT OF THE BOOK FOR ILLUSTRATIONS DETAILING THE LOCATION AND IDENTIFICATION OF COMPONENTS, RELAYS, CONNECTORS, HARNESSES, GROUNDS, VEHICLE CONTROL MODULES AND CONTROL MODULE PINS.

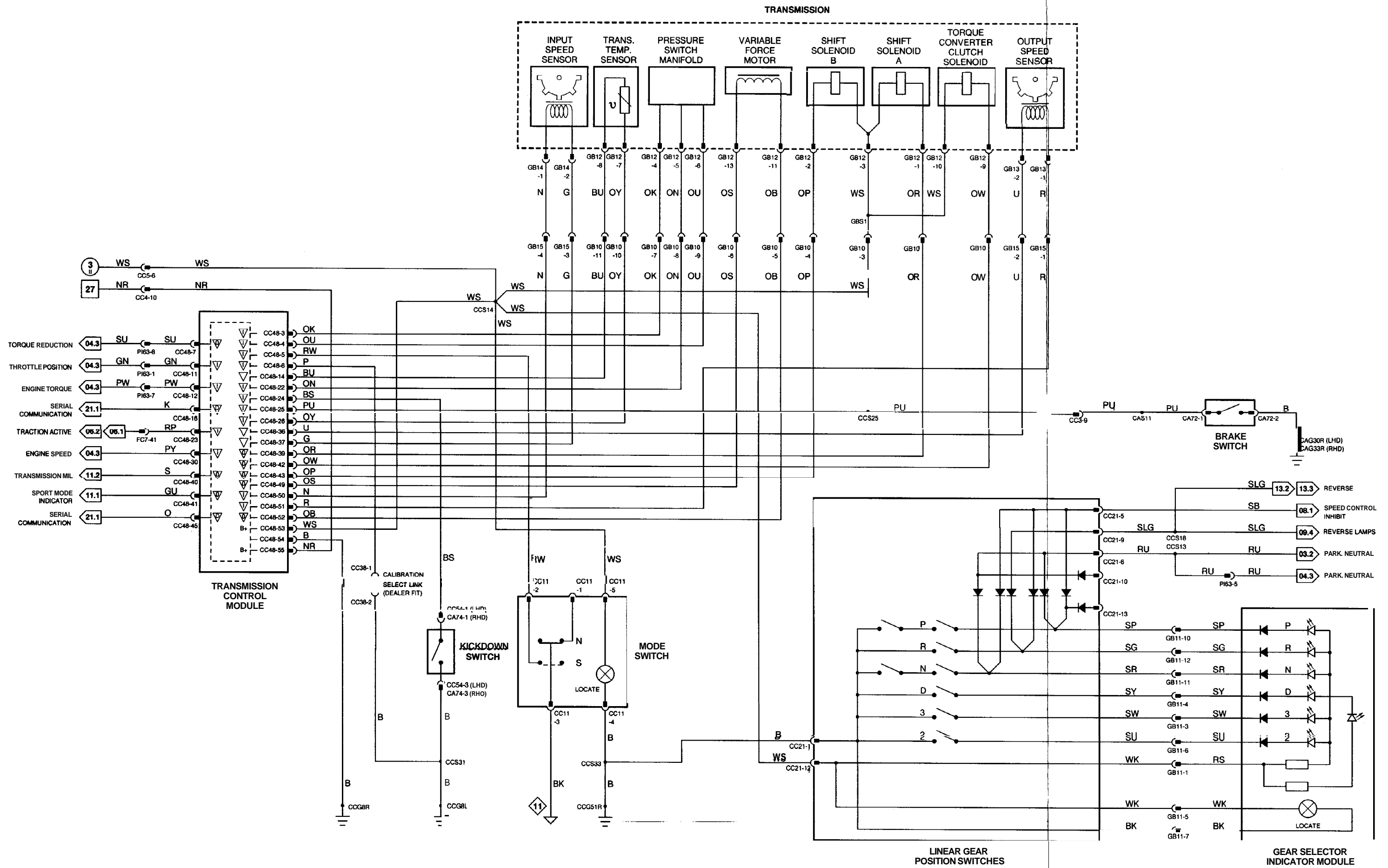

**Fig. 05.3**

**COMPONENTS**

<b>Component</b>	<b>Connector / Type / Color</b>	<b>Location / Access</b>
LINEAR GEAR POSITION SWITCHES	CC21 120-WAY MULTILOCK040 / BLACK	'J' GATE / CENTER CONSOLE
GEAR SELECTOR INDICATOR MODULE (AJ163.2L, 4.0L SC: V12)	GB11 (FLY LEAD) 112-WAY MULTILOCK040 / BLACK	'J' GATE / CENTER CONSOLE

**HARNESS-TO-HARNESSCONNECTORS**

<b>Connector</b>	<b>Type / Color</b>	<b>Location / Access</b>
CC5	20-WAY MULTILOCK040 / GREEN	CENTER CONSOLE / CENTER CONSOLE GLOVE BOX
PI63	20-WAY MULTILOCK040 / BLACK	RH 'A' POST / 'A' POSTTRIM

**GROUNDS**

<b>Ground</b>	<b>Location / Type</b>
CCG51R	CENTER WNSOLE GROUNDSTUD

REFER TO THE FRONT OF THE BOOK OR ILLUSTRATIONS DETAILING THE LOCATION AND IDENTIFICATION OF COMPONENTS, RELAY CONNECTORS, ARMATURES, AND CONTROL MODULE PINS.

DATE OF ISSUE: JANUARY 1995



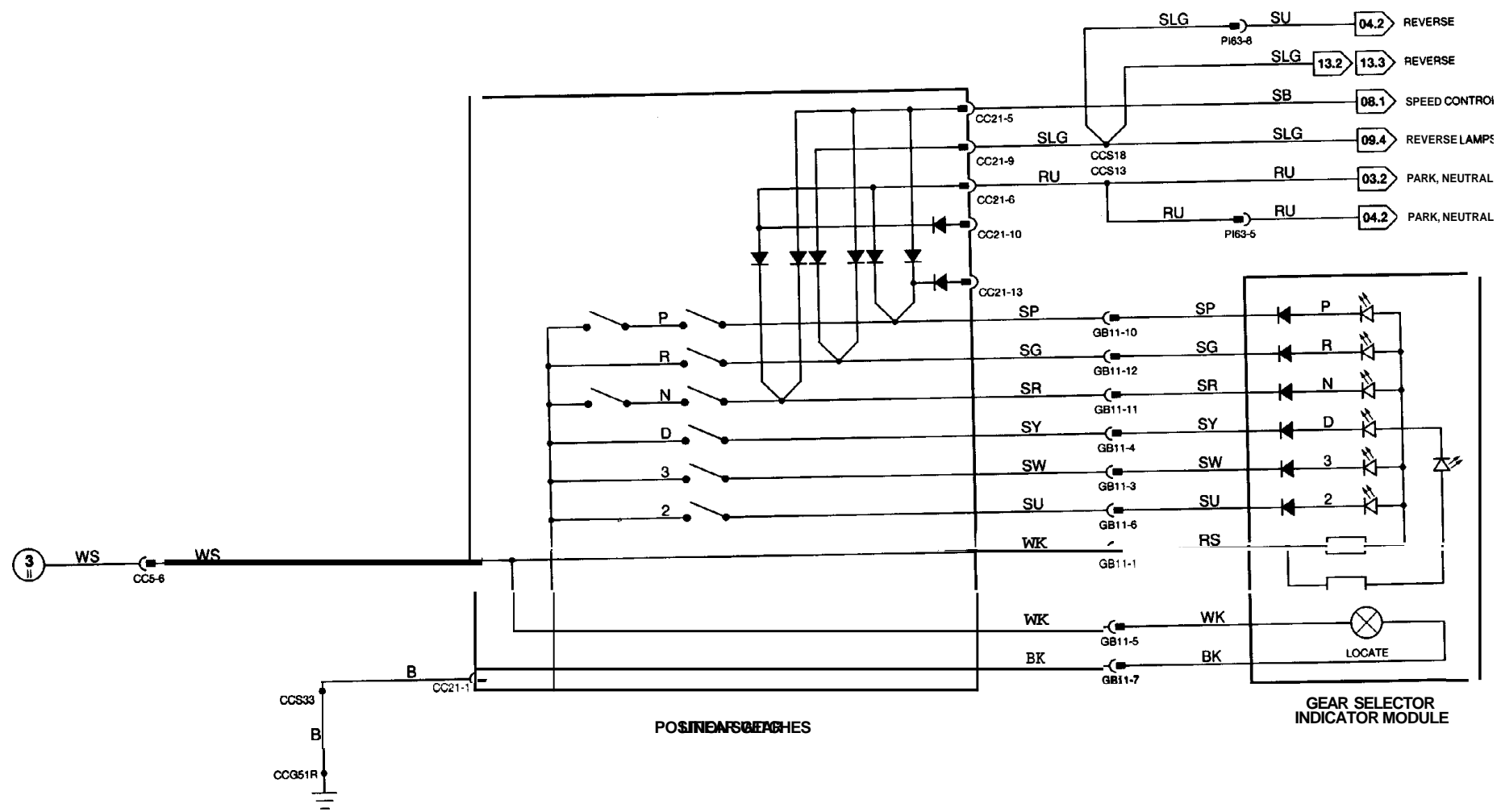

CONTROL MODULE PIN OUT INFORMATION

TRANSMISSION CONTROL MODULE (V12)

Pin	Description	Active	Inactive
I C m - 3	PRESSURE SWITCH MANIFOLD	B+	B+
I CC48-4	PRESSURE SWITCH MANIFOLD	B+	B+
I CC48-5	MODE SWITCH	GROUND = SPORT	B+ = NORMAL
I CC48-6	CALIBRATION SELECT LINK (DEALER FIT)	GROUND = (FITTED)	B+
O CC48-7	TORQUE REDUCTION	GROUND PULSE @ SHIFT	11.5 V @ IDLE
I CC48-11	THROTTLE POSITION	1.4 V @ IDLE	9 V @ FULL THROTTLE
I CC48-12	ENGINE TORQUE	11.5 V @ IDLE. DECREASING WITH TORQUE INCREASE	
SG CC48-14	TRANSMISSION TEMPERATURE SENSOR	GROUND	GROUND
O CC48-16	SERIAL COMMUNICATION INPUT		
I CC48-22	PRESSURE SWITCH MANIFOLD	GROUND	GROUND
I CC48-23	TRACTION ACTIVE	GROUND	B+
I CC48-24	KICK DOWN SWITCH	GROUND	B+
I CC48-25	BRAKE SWITCH	GROUND	B+
I CC48-26	TRANSMISSION TEMPERATURE SENSOR	1.93 V @ 90° C	
I CC48-30	ENGINE SPEED SIGNAL	5 V @ 1000 RPM - 45 Hz, 2000 RPM = 90 Hz	
O CC48-34	VEHICLE SPEED SIGNAL	GROUND	B+
SG CC48-36	OUTPUT SPEED SENSOR	GROUND	GROUND
SG CC48-37	INPUT SPEED SENSOR	GROUND	GROUND
O CC48-39	SHIFT SOLENOID 'A'	GROUND - 1.4	B+ = 2, 3
O CC48-40	TRANSMISSION MIL	GROUND	B+
O CC48-41	SPORT MODE INDICATOR LAMP	GROUND	B+
O CC48-42	TORQUE CONVERTER CLUTCH SOLENOID	GROUND	B+
O CC48-43	SHIFT SOLENOID 'B'	GROUND = 3.4	B+ = 1, 2
D CC48-45	SERIAL COMMUNICATION OUTPUT		
O CC48-49	VARIABLE FORCE MOTOR	1.3 V @ IDLE. DECREASING WITH PRESSURE INCREASE	
I CC48-50	INPUT SPEED SENSOR	GROUND @ 1000 RPM = 450 Hz, 2000 RPM = 900 Hz	
I CC48-51	OUTPUT SPEED SENSOR	GROUND @ 10 MPH (16 KPH) = 300 Hz, 20 MPH (32 KPH) = 600 Hz	
O CC48-52	VARIABLE FORCE MOTOR	7.1 V @ IDLE. DECREASING WITH PRESSURE INCREASE	

Fig. 05.4

COMPONENTS

Component	Connector / Type / Color	Location / Access
BRAKE SWITCH	CA72 / 4-WAY MULTILOCK 070 / WHITE	DRIVER'S UNDERSCUTTLE
GEAR SELECTOR INDICATOR MODULE (AJ16 3.2L, 4.0L SC, V12)	GB11 (FLY LEAD) / 12-WAY MULTILOCK 040 / BLACK	'J' GATE / CENTER CONSOLE
INPUT SPEED SENSOR	GB14 (FLY LEAD) / 3-WAY PACKARD / BLACK	TRANSMISSION, LH SIDE
KICKDOWN SWITCH	CA74 (RHD) (FLY LEAD) / 3-WAY MULTILOCK 070 / SLATE CC54 (LHD) (FLY LEAD) / 3-WAY MULTILOCK 070 / SLATE	UNDER ACCELERATOR
LINEAR GEAR POSITION SWITCHES	CC21 120-WAY MULTILOCK 040 / BLACK	'J' GATE / CENTER CONSOLE
MODE SWITCH	CC11 16-WAY MULTILOCK 040 / BLACK	CENTER CONSOLE
OUTPUT SPEED SENSOR	GB13 (FLY LEAD) / 3-WAY PACKARD / BLACK	TRANSMISSION, LH SIDE
PRESSURE SWITCH MANIFOLD	GB12 / 12-WAY HELLERMAN DEUTSCH / BLACK	TRANSMISSION / SUMP
SHIFT SOLENOID (A)	GB12 / 12-WAY HELLERMAN DEUTSCH / BLACK	TRANSMISSION / SUMP
SHIFT SOLENOID (B)	GB12 / 12-WAY HELLERMAN DEUTSCH / BLACK	TRANSMISSION / SUMP
TORQUE CONVERTER CLUTCH SOLENOID	GB12 / 12-WAY HELLERMAN DEUTSCH / BLACK	TRANSMISSION / SUMP
TRANSMISSION CONTROL MODULE (V12 & AJ16 SC)	CC48 / 8-WAY AMP 55 / BLACK	PASSENGER'S UNDERSCUTTLE
TRANSMISSION TEMPERATURE SENSOR	GB12 / 12-WAY HELLERMAN DEUTSCH / BLACK	TRANSMISSION / SUMP
VARIABLE FORCE MOTOR	GB12 / 12-WAY HELLERMAN DEUTSCH / BLACK	TRANSMISSION / SUMP

HARNESSTO-HARNESCONNECTORS

Connector	Type / Color	Location / Access
CC3	20-WAY MULTILOCK 040 / BLACK	CENTER CONSOLE / CENTER CONSOLE GLOVE BOX
CC4	14-WAY MULTILOCK 070 / WHITE	CENTER CONSOLE / CENTER CONSOLE GLOVE BOX
CC5	20-WAY MULTILOCK 040 / GREEN	CENTER CONSOLE / CENTER CONSOLE GLOVE BOX
CC38	2-WAY MULTILOCK 070 / YELLOW	PASSENGER'S UNDERSCUTTLE
FC7	THROUGH-PANEL / 48 MICRO / BLACK	PASSENGER'S UNDERSCUTTLE
GB10	12-WAY MULTILOCK 040 / BLACK	CENTER CONSOLE / CENTER CONSOLE
GB15	0-WAY MULTILOCK 070 / WHITE	CENTER CONSOLE / CENTER CONSOLE
PI63	20-WAY MULTILOCK 040 / BLACK	RH 'A' POST / 'A' POST TRIM

GROUNDS

Ground	Location / Type
CAG30R	LH 'A' POST GROUND SCREW
CAGUR	RH HEELBOARD GROUND SCREW
CCG51R	CENTER CONSOLE GROUND STUD
CCG8L	CENTER CONSOLE GROUND STUD
CCG8R	CENTER CONSOLE GROUND STUD

CONTROL MODULE PIN OUT INFORMATION (FOLD OUT PAGE)



The following symbols are used to represent values for Control Module Pin Out data:

<b>I</b> Input	<b>B+</b> Battery voltage
<b>O</b> Output	<b>V</b> Voltage (DC)
<b>SG</b> Signal Ground	<b>Hz</b> Frequency
<b>D</b> Serial and encoded communications	<b>KHz</b> Frequency x 1000
	<b>MS</b> Milliseconds
	<b>MV</b> Millivolts

CAUTION: The information on this data page is furnished to aid the user in understanding circuit operation. THIS INFORMATION SHOULD BE USED FOR REFERENCE ONLY.

NOTE: The values listed are approximately those that can be expected at the control module connector pins with all circuit connections made and all components connected and fitted. "Active" means a load is applied or a switch is ON; "Inactive" means a load is not applied or a switch is OFF.

REFER TO THE FRONT OF THE BOOK FOR ILLUSTRATIONS DETAILING THE LOCATION AND IDENTIFICATION OF COMPONENTS, RELAYS, CONNECTORS, HARNESSES, GROUNDS, VEHICLE CONTROL MODULES AND CONTROL MODULE PINS.

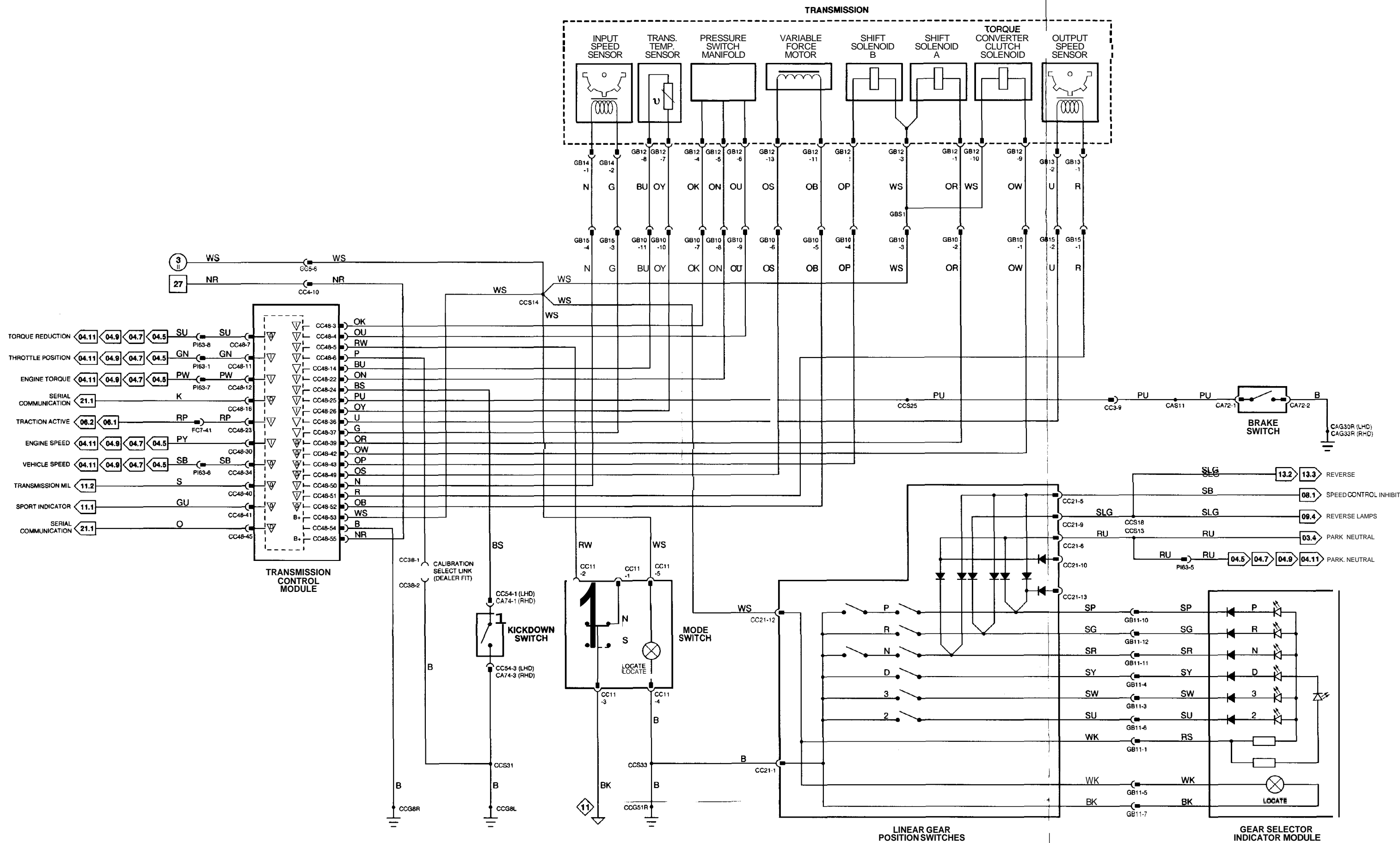

CONTROL MODULE PIN OUT INFORMATION

BODY PROCESSOR MODULE

Pin	Description	Active	Inactive
O FC1-25	KEY LOCK SOLENOID RELAY	GROUND	B+
O FC1-28	GEARSHIFT INTERLOCK RELAY	GROUND	B+
I FC2-16	NOT IN PARK MICRO SWITCH	GROUND	B+
I FC2-31	IGNITION SWITCHED GROUND	GROUND	B+
I FC2-35	BRAKE SWITCH	GROUND	B+

**Fig. 05.5**

COMPONENTS

Component	Connector ■Type / Color	Location / Access
BODY PROCESSOR MODULE	FC1 / 48-WAY PCB SIGNAL ■YELLOW FC2 / 48-WAY PCB SIGNAL 1 ■BLACK FC3 / 6-WAY PCB SIGNAL ■BLACK	PASSENGERS UNDERSCUTTLE
BRAKE SWITCH	CA72 14-WAY MULTILOCK 070 ■WHITE	DRIVER'S UNDERSCUTTLE
GEARSHIFT INTERLOCKSOLENOID	CC12 ■MULTILOCK 070 ■WHITE	'J' GATE ■CENTER CONSOLE
KEYLOCK SOLENOID (COLUMN SWITCHGEAR)	SC6 / 2-WAY MULTILOCK 040 / BLUE	STEERING COLUMN ■COVER
NOT IN-PARKMICROSWITCH	CC42 (FLY LEAD) 12-WAY MULTILOCK 040 / BLACK	'J' GATE / CENTER CONSOLE

RELAYS

Relay	Color / Stripe	Connector ■Color	Location ■Access
GEARSHIFT INTERLOCK RELAY	BLUE	CC23 ■BLUE	CENTER CONSOLE
KEYLOCK SOLENOID RELAY	BLACK ■BLUE	CC23 ■BLUE	CENTER CONSOLE

HARNESS-TO-HARNESSCONNECTORS

Connector	Type / Color	Location / Access
CC3	20-WAY MULTILOCK 040 / BLACK	CENTER CONSOLE ■CENTER CONSOLE GLOVE BOX
FC7	THROUGH PANEL (48 MICRO / 6) ■BLACK	PASSENGERS UNDERSCUTTLE
FC16	20-WAY MULTILOCK 040 / BLACK	PASSENGERS UNDERSCUTTLE
FC8	12-WAY MULTILOCK 040 / BLACK	DRIVERS UNDERSCUTTLE

GROUNDS

Ground	Location / Type
CAG30R	LH 'A' POST GROUND SCREW
CAG33R	RH HEELBOARDGROUNDSCREW
CCG51L	CENTER CONSOLE GROUND STUD
CCG51R	CENTER CONSOLE GROUND STUD
FCG15L	LH CONSOLE GROUND STUD
FCG26R	LH CONSOLE GROUND STUD

CONTROL MODULE PIN OUT INFORMATION (FOLD OUT PAGE)



The following symbols are used to represent values for Control Module Pin *Out* data:

I Input	B+ Battery voltage
O output	V Voltage (DC)
SG Signal Ground	Hz Frequency
D Serial and encoded communications	KHz Frequencyx 1000
	MS Milliseconds
	MV Millivolts

CAUTION: The information on this data page is furnished to aid the user in understanding circuit operation. THIS INFORMATION SHOULD BE USED FOR REFERENCE ONLY.

NOTE: The values listed are approximately those that can be expected at the control module connector pins with all circuit connections made and all components connected and fitted. 'Active' means a load is applied or a switch is ON; 'Inactive' means a load is not applied or a switch is OFF.

REFER TO THE FRONT OF THE BOOK FOR ILLUSTRATIONS DETAILING THE LOCATION AND IDENTIFICATION OF COMPONENTS, RELAYS, CONNECTORS, HARNESSES, GROUNDS, VEHICLE CONTROL MODULES AND CONTROL MODULE PINS.

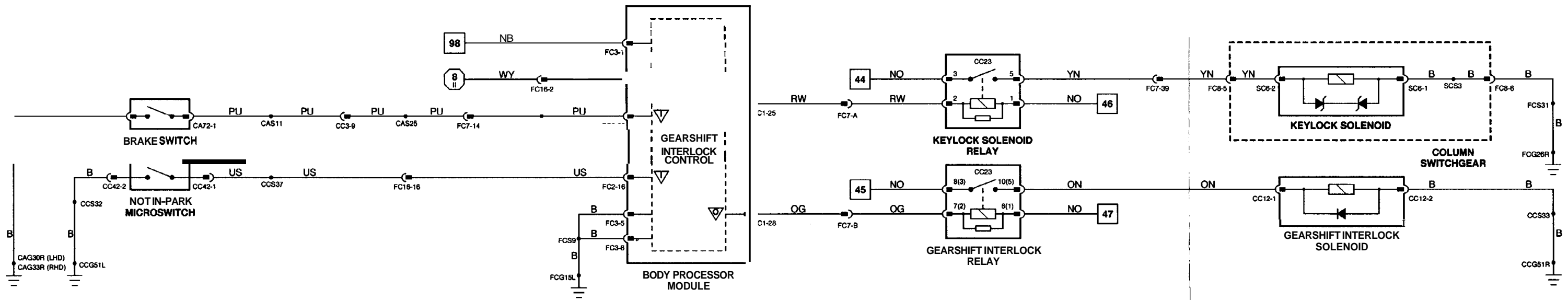

CONTROL MODULE PIN OUT INFORMATION

ABS ■ TRACTION CONTROL CONTROL MODULE (LHD)

Pin	Description	Active	Inactive
O RS27-3	TRACTION CONTROL ACTIVE SIGNAL TO TCM	GROUND	B+
O RS27-4	SPEED CONTROL INHIBIT REQUEST	GROUND	B+
I RS27-5	LH FRONT WHEEL SPEED SENSOR	2.5 V @ 10 MPH (16 KPH) = 100 Hz; 20 MPH (32 KPH) = 200 Hz 2.5 V IAT REST	2.5 V
SG RS27-6	LH FRONT WHEEL SPEED SENSOR GROUND		
I RS27-7	RH FRONT WHEEL SPEED SENSOR	2.5 V @ 10 MPH (16 KPH) = 100 Hz; 20 MPH (32 KPH) = 200 Hz 2.5 V IAT REST	2.5 V
SG RS27-8	RH FRONT WHEEL SPEED SENSOR GROUND		
I RS27-9	LH REAR WHEEL SPEED SENSOR	2.5 V @ 10 MPH (16 KPH) = 100 Hz; 20 MPH (32 KPH) = 200 Hz 2.5 V IAT REST	2.5 V
SG RS27-10	LH REAR WHEEL SPEED SENSOR GROUND		
I RS27-11	RH REAR WHEEL SPEED SENSOR	2.5 V @ 10 MPH (16 KPH) = 100 Hz; 20 MPH (32 KPH) = 200 Hz 2.5 V IAT REST	2.5 V
SG RS27-12	RH REAR WHEEL SPEED SENSOR GROUND		
O RS27-16	TRACTION CONTROL ACTUATOR MOTOR	GROUND	7 V
O RS27-17	TRACTION CONTROL ACTUATOR MOTOR	GROUND	7 V
I RS27-18	TRACTION CONTROL INHIBIT SWITCH	GROUND	B+
I RS27-20	BRAKE SWITCH INPUT	GROUND	B+
O RSD-21	ABS FAILURE LAMP	GROUND	2.3 V
O RS27-23	TRACTION INDICATOR LAMP	B+	FAILURE = GROUND TRACTION OFF = 4 Hz GROUND PULSE
O RS27-24	VEHICLE SPEED SIGNAL	B+ @ 10 MPH (16 KPH) = 200 Hz; 20 MPH (32 KPH) = 400 Hz 5 v	5 v
O RS27-25	ACTUATOR POTENTIOMETER REFERENCE VOLTAGE		0 - 5 V (FLUCTUATING)
I RSD-26	ACTUATOR POTENTIOMETER FEEDBACK		GROUND
SG RS27-27	ACTUATOR POTENTIOMETER REFERENCE GROUND		
D RS27-28	SERIAL COMMUNICATION (BI-DIRECTIONAL)		

Fig. 06.1

COMPONENTS

Component	Connector / Type / Color	Location ■ Access
ABS TRACTION CONTROL CONTROL MODULE (LHD)	RS27 128-WAY FORD GTE ■ SLATE	ENGINE BAY / RH REAR
BRAKE SWITCH	CA72 / 4-WAY MULTILOCK 070 / WHITE	DRIVER'S UNDERSCUTTLE
FASCIA SWITCH PACK	FC18 / 16-WAY MULTILOCK 040 / BLACK	STEERING COLUMN ■ DRIVER'S UNDERSCUTTLE
TRACTION CONTROL ACTUATOR (LHD)	RS39 (FLY LEAD) / 2-WAY FORD ■ BLACK RS50 / 3-WAY JUNIOR TIMER ■ BLACK	ENGINE BAY, LH REAR
WHEEL SPEED SENSOR - LH FRONT	LS34 (FLY LEAD) / 12-WAY ECONOSEAL 111 LC ■ BLACK	LH FRONT WHEEL
WHEEL SPEED SENSOR - LH REAR	CA48 (FLY LEAD) / 2-WAY ECONOSEAL III LC ■ BLACK	LH REAR WHEEL
WHEEL SPEED SENSOR - RH FRONT	RS28 (FLY LEAD) / 2-WAY ECONOSEAL 111 LC ■ BLACK	RH FRONT WHEEL
WHEEL SPEED SENSOR - RH REAR	CA47 (FLY LEAD) / 2-WAY ECONOSEAL 111 LC ■ BLACK	RH REAR WHEEL

HARNESS-TO-HARNESS CONNECTORS

Connector	Type / Color	Location / Access
FC5	THROUGH-PANEL (48 MICRO / 6) / BLACK	LH FASCIA END PANEL ■ OUTER AIR VENT
FC6	THROUGH-PANEL (48 MICRO / 6) ■ BLACK	RH FASCIA END PANEL ■ OUTER AIR VENT
FC57	12-WAY MULTILOCK 040 ■ BLACK	PASSENGERS UNDERSCUTTLE
LS3	THROUGH-PANEL (48 MICRO / 6) ■ BLACK	LH 'A' POST / 'A' POST PANEL
RS3	THROUGH-PANEL (48 MICRO / 6) ■ BROWN	RH 'A' POST / 'A' POST PANEL

GROUNDS

Ground	Location ■ Type
CAG30R	LH 'A' POST GROUND SCREW
FCG26L	LH CONSOLE GROUND STUD
RS41L	RIGHT FORWARD GROUND STUD
RS41R	RIGHT FORWARD GROUND STUD
RS42L	RH BULKHEAD GROUND STUD

CONTROL MODULE PIN OUT INFORMATION (FOLD OUT PAGE)



The following symbols are used to represent values for Control Module Pin Out data:

I	Input	B+	Battery voltage
O	Output	V	Voltage (DC)
SG	Signal Ground	Hz	Frequency
D	Serial and encoded communications	KHz	Frequency x 1000
		MS	Milliseconds
		MV	Millivolts

CAUTION: The information on this data page is furnished to aid the user in understanding circuit operation. THIS INFORMATION SHOULD BE USED FOR REFERENCE ONLY.

NOTE: The values listed are approximately those that can be expected at the control module connector pins with all circuit connections made and all components connected and fitted. "Active" means a load is applied or a switch is ON; "Inactive" means a load is not applied or a switch is OFF.

REFER TO THE FRONT OF THE BOOK FOR ILLUSTRATIONS DETAILING THE LOCATION AND IDENTIFICATION OF COMPONENTS, RELAYS, CONNECTORS, HARNESES, GROUNDS, VEHICLE CONTROL MODULES AND CONTROL MODULE PINS.

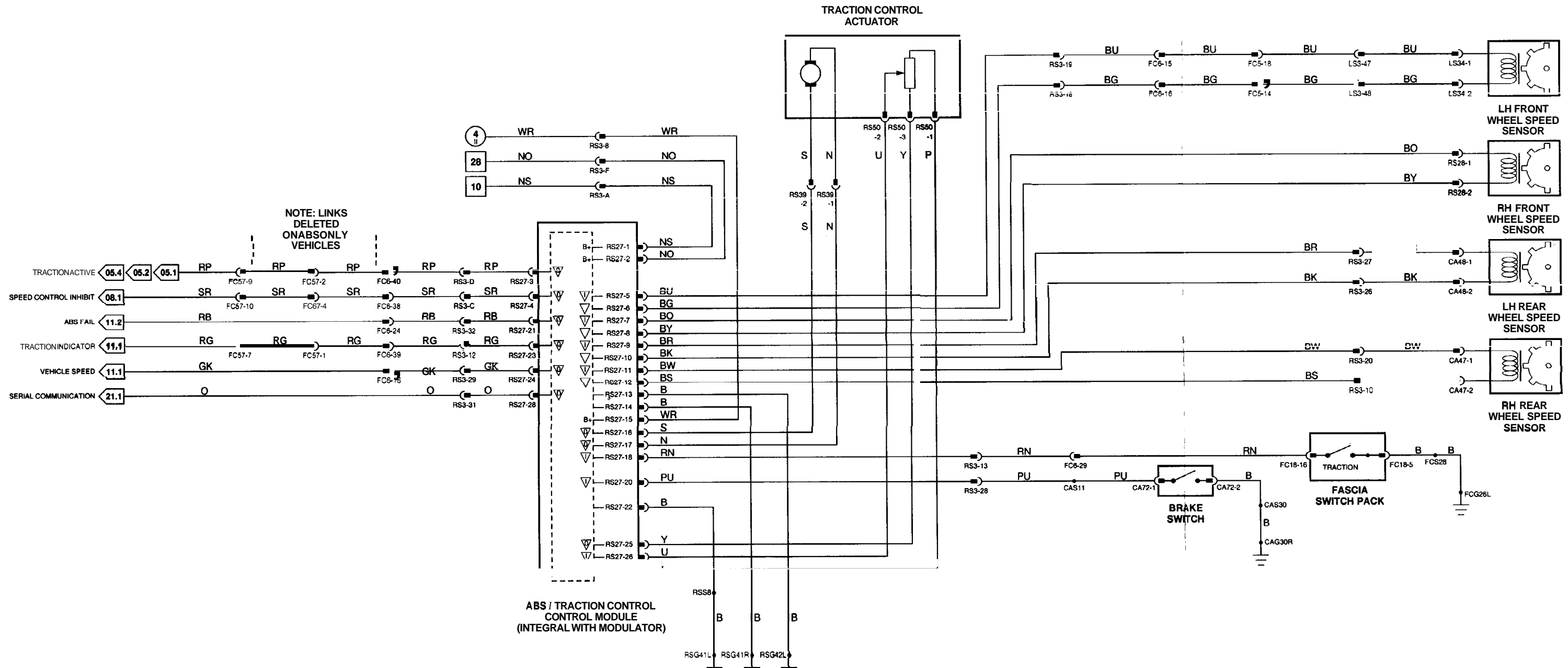

CONTROL MODULE PIN OUT INFORMATION

ABS / TRACTION CONTROL CONTROL MODULE (RHD)

Pin	Description	Active	Inactive
O LS27-3	TRACTION CONTROL ACTIVE SIGNAL TO TCM	GROUND	B+
O LS27-4	SPEED CONTROL INHIBIT REQUEST	GROUND	B+
I LS27-5	LH FRONT WHEEL SPEED SENSOR	2.5 V @ 10 MPH (16 KPH) = 100 Hz; 20 MPH (32 KPH) = 200 Hz	
SG LS27-6	LH FRONT WHEEL SPEED SENSOR GROUND	2.5 V (AT REST)	2.5 V
I LS27-7	RH FRONT WHEEL SPEED SENSOR	2.5 V @ 10 MPH (16 KPH) = 100 Hz; 20 MPH (32 KPH) = 200 Hz	
SG LS27-8	RH FRONT WHEEL SPEED SENSOR GROUND	2.5 V (AT REST)	2.5 V
I LS27-9	LH REAR WHEEL SPEED SENSOR	2.5 V @ 10 MPH (16 KPH) = 100 Hz; 20 MPH (32 KPH) = 200 Hz	
SG LS27-10	LH REAR WHEEL SPEED SENSOR GROUND	2.5 V IAT REST	2.5 V
I LS27-11	RH REAR WHEEL SPEED SENSOR	2.5 V @ 10 MPH (16 KPH) = 100 Hz; 20 MPH (32 KPH) = 200 Hz	
SG LS27-12	RH REAR WHEEL SPEED SENSOR GROUND	2.5 V IAT REST	2.5 V
O LS27-16	TRACTION CONTROL ACTUATOR MOTOR	GROUND	7 v
O LS27-17	TRACTION CONTROL ACTUATOR MOTOR	GROUND	7 v
I LS27-18	TRACTION CONTROL INHIBIT SWITCH	GROUND	B+
I LS27-20	BRAKE SWITCH INPUT	GROUND	B+
O LS27-21	ABS FAILURE LAMP	GROUND	2.3V
O LS27-23	TRACTION INDICATOR LAMP	B+	FAILURE = GROUND TRACTION OFF = 4 Hz GROUND PULSE
O LS27-24	VEHICLE SPEED SIGNAL	B+ @ 10 MPH (16 KPH) = 200 Hz; 20 MPH (32 KPH) = 400 Hz	
O LS27-25	ACTUATOR POTENTIOMETER REFERENCE VOLTAGE	5 v	5 V
I LS27-26	ACTUATOR POTENTIOMETER FEEDBACK	0 - 5 V (FLUCTUATING)	0.47 V IAT REST
SG LS27-27	ACTUATOR POTENTIOMETER REFERENCE GROUND	GROUND	GROUND
D LS27-28	SERIAL COMMUNICATION (BIDIRECTIONAL)		

The following symbols are used to represent values for Control Module Pin Out data:

I	Input	B+	Battery voltage
O	Output	V	Voltage (DC)
SG	Signal Ground	Hz	Frequency
D	Serial and encoded communications	K k	Frequency x 1000
		MS	Milliseconds
		MV	Millivolts

CAUTION: The information on this data page is furnished to aid the user in understanding circuit operation. THIS INFORMATION SHOULD BE USED FOR REFERENCE ONLY.

NOTE: The values listed are approximately those that can be expected at the control module connector pins with all circuit connections made and all components connected and fitted. "Active" means a load is applied or a switch is ON; "Inactive" means a load is not applied or a switch is OFF.

Fig. 06.2

COMPONENTS

Component	Connector / Type / Color	Location / Access
ABS / TRACTION CONTROL CONTROL MODULE (RHD)	LS27 128-WAY FORDGTE / SLATE	ENGINE BAY / LH REAR
BRAKE SWITCH	CA72 / 4-WAY MULTILOCK 070 / WHITE	DRIVER'S UNDERSCUTTLE
FASCIA SWITCH PACK	FC18 / 16-WAY MULTILOCK 040 / BLACK	STEERING COLUMN / DRIVER'S UNDERSCUTTLE
TRACTION CONTROL ACTUATOR (RHD)	LS39 (FLY LEAD) / 2-WAY FORD / BLACK LS50 13-WAY JUNIOR TIMER / BLACK	ENGINE BAY, RH REAR
WHEEL SPEED SENSOR - LH FRONT	LS34 (FLY LEAD) 12-WAY ECONOSEAL III LC / BLACK	LH FRONT WHEEL
WHEEL SPEED SENSOR - LH REAR	CA40 (FLY LEAD) 12-WAY ECONOSEAL III LC / BLACK	LH REAR WHEEL
WHEEL SPEED SENSOR - RH FRONT	RS28 (FLY LEAD) 12-WAY ECONOSEAL III LC / BLACK	RH FRONT WHEEL
WHEEL SPEED SENSOR - RH REAR	CA47 (FLY LEAD) / 2-WAY ECONOSEAL III LC / BLACK	RH REAR WHEEL

HARNESSTO-HARNESCONNECTORS

Connector	Type / Color	Location / Access
FC5	THROUGH-PANEL (48 MICRO / 6) / BLACK	LH FASCIA END PANEL / OUTER AIR VENT
FC6	THROUGH-PANEL (48 MICRO / 6) / BLACK	RH FASCIA END PANEL / OUTER AIR VENT
FC57	12-WAY MULTILOCK 040 / BLACK	PASSENGER'S UNDERSCUTTLE
LS3	THROUGH-PANEL (48 MICRO / 6) / BLACK	LH 'A' POST / 'A' POST PANEL
RS3	THROUGH-PANEL (48 MICRO / 6) / BROWN	RH 'A' POST / 'A' POST PANEL

GROUNDS

Ground	Location / Type
CAG33R	RH HEELBOARD GROUND SCREW
FCG26L	LH CONSOLE GROUND STUD
LSG10R	LEFT FORWARD GROUND STUD
LSG19R	LH BULKHEAD GROUND STUD
LSG51L	LH BULKHEAD GROUND STUD

CONTROL MODULE PIN OUT INFORMATION (FOLD OUT PAGE)



REFER TO THE FRONT OF THE BOOK FOR ILLUSTRATIONS DETAILING THE LOCATION AND IDENTIFICATION OF COMPONENTS, RELAYS, CONNECTORS, HARNESSES, GROUNDS, VEHICLE CONTROL MODULES AND CONTROL MODULE PINS.



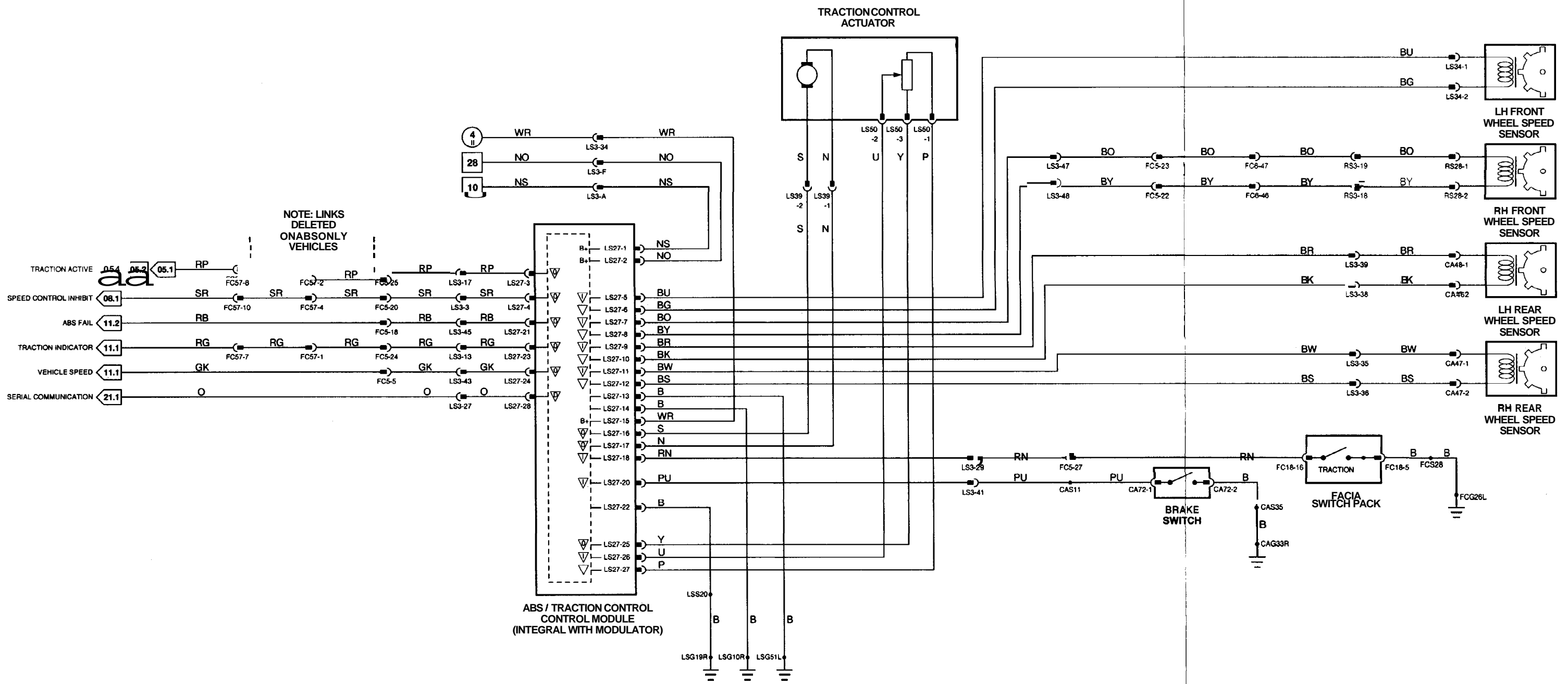

CONTROL MODULE PIN OUT INFORMATION

AIR CONDITIONING CONTROL MODULE

Pin	Description	Active	Inactive
I CC28-1	COMPRESSOR CLUTCH ON SIGNAL	B+	GROUND
O CC31-9	COMPRESSOR CLUTCH REQUEST	GROUND	B+
I CC31-17	REFRIGERANT TRIPLE PRESSURE SWITCH - 4.01 REFRIGERANT DUAL PRESSURE SWITCH - V12	GROUND	B+

ENGINE CONTROL MODULE (AJ16)

Pin	Description	Active	Inactive
O P1104-21	AIR CONDITIONING CLUTCH RELAY	GROUND	B+
I P1105-36	AIR CONDITIONING REQUEST	GROUND	B+

Fig. 07.1

COMPONENTS

Component	Connector / Type / Color	Location / Access
AIR CONDITIONING COMPRESSOR CLUTCH AIR CONDITIONING CONTROL MODULE	P1138 / 3-WAY JUNIOR TIMER / BLACK CC28 / 126-WAY MULTILOCK47 / SLATE CC29 / 116-WAY MULTILOCK47 / SLATE CC30 / 12-WAY MULTILOCK47 / SLATE CC31 / 22-WAY MULTILOCK47 / SLATE	A/C COMPRESSOR A/C UNIT, RH SIDE / RH UNDERSCUTTLE
ENGINE CONTROL MODULE (AJ16)	P1104 / 36-WAY ECONOSEAL 111 / BLACK P1105 / 36-WAY ECONOSEAL 111 / RED	RH 'A' POST / 'A' POSTTRIM
FAN CONTROL RELAY MODULE RADIATOR COOLING FAN (LH) RADIATOR COOLING FAN (RH) RADIATOR THERMOSTATIC SWITCH REFRIGERANT SINGLE PRESSURE SWITCH REFRIGERANT TRIPLE PRESSURE SWITCH SUPERCHARGER INTERCOOLER COOLANT PUMP	LS18 / 8-WAY TRW / BLACK CF1 / 2-WAY REINSHAGEN / BLACK CFZ / 2-WAY REINSHAGEN / BLACK LS12 / 3-WAY JUNIOR TIMER / BLACK P1102 (FLY LEAD) / 2-WAY ECONOSEAL 111 LC / WHITE P1103 (FLY LEAD) / 4-WAY ECONOSEAL 111 LC / BLACK P1143 (FLY LEAD) / 2-WAY ECONOSEAL 111 LC / BLACK	BELOW LH HEADLAMPS ENGINE BAY, FRONT ENGINE BAY, FRONT RADIATOR, LOWER LH SIDE ENGINE BAY, RH REAR ENGINE BAY, RH REAR ENGINE BAY, LH FRONT

RELAYS

Relay	Color / Stripe	Connector / Color	Location / Access
AIR CONDITIONING CLUTCH RELAY	BLACK / WHITE	P1145 / BLACK	RH ENGINE BAY RELAYS

HARNESS-TO-HARNESS CONNECTORS

Connector	Type / Color	Location / Access
LS11	4-WAY ECONOSEAL 111 HC / BLACK	SPOILER, LH SIDE / SPOILER
PI1	13-WAY ECONOSEAL 111 LC / WHITE	RH AIR CLEANER
PI59	13-WAY ECONOSEAL 111 LC / BLACK	LH AIR CLEANER
PI61	13-WAY ECONOSEAL 111 LC / BLACK	RH AIR CLEANER
PI63	20-WAY MULTILOCK 040 / BLACK	RH 'A' POST / 'A' POSTTRIM
RS3	THROUGH-PANEL (48 MICRO / 6) / BROWN	RH 'A' POST / 'A' POSTPANEL

GROUNDS

Ground	Location / Type
LSG10L	LEFT FORWARD GROUND STUD
LSG10R	LEFT FORWARD GROUND STUD
LSG51R	LH BULKHEAD GROUND STUD
LSG52R	LEFT FORWARD GROUND STUD
PIG153R	RH BULKHEAD GROUND STUD
PIG154L	LEFT FORWARD GROUND STUD
PIG154R	LEFT FORWARD GROUND STUD

CONTROL MODULE PIN OUT INFORMATION (FOLD OUT PAGE)



The following symbols are used to represent values for Control Module Pin Out data:

I	Input	B+	Battery voltage
O	Output	V	Voltage (DC)
SG	Signal Ground	Hz	Frequency
D	Serial and encoded communications	KHz	Frequency x 1000
		MS	Milliseconds
		MV	Millivolts

CAUTION: The information on this data page is furnished to aid the user in understanding circuit operation. THIS INFORMATION SHOULD BE USED FOR REFERENCE ONLY.

NOTE: The values listed are approximately those that can be expected at the control module connector pins with all circuit connections made and all components connected and fitted. "Active" means a load is applied or a switch is ON; "Inactive" means a load is not applied or a switch is OFF.

REFER TO THE FRONT OF THE BOOK FOR ILLUSTRATIONS DETAILING THE LOCATION AND IDENTIFICATION OF COMPONENTS, RELAYS, CONNECTORS, HARNESES, GROUNDS, VEHICLE CONTROL MODULES AND CONTROL MODULE PINS.

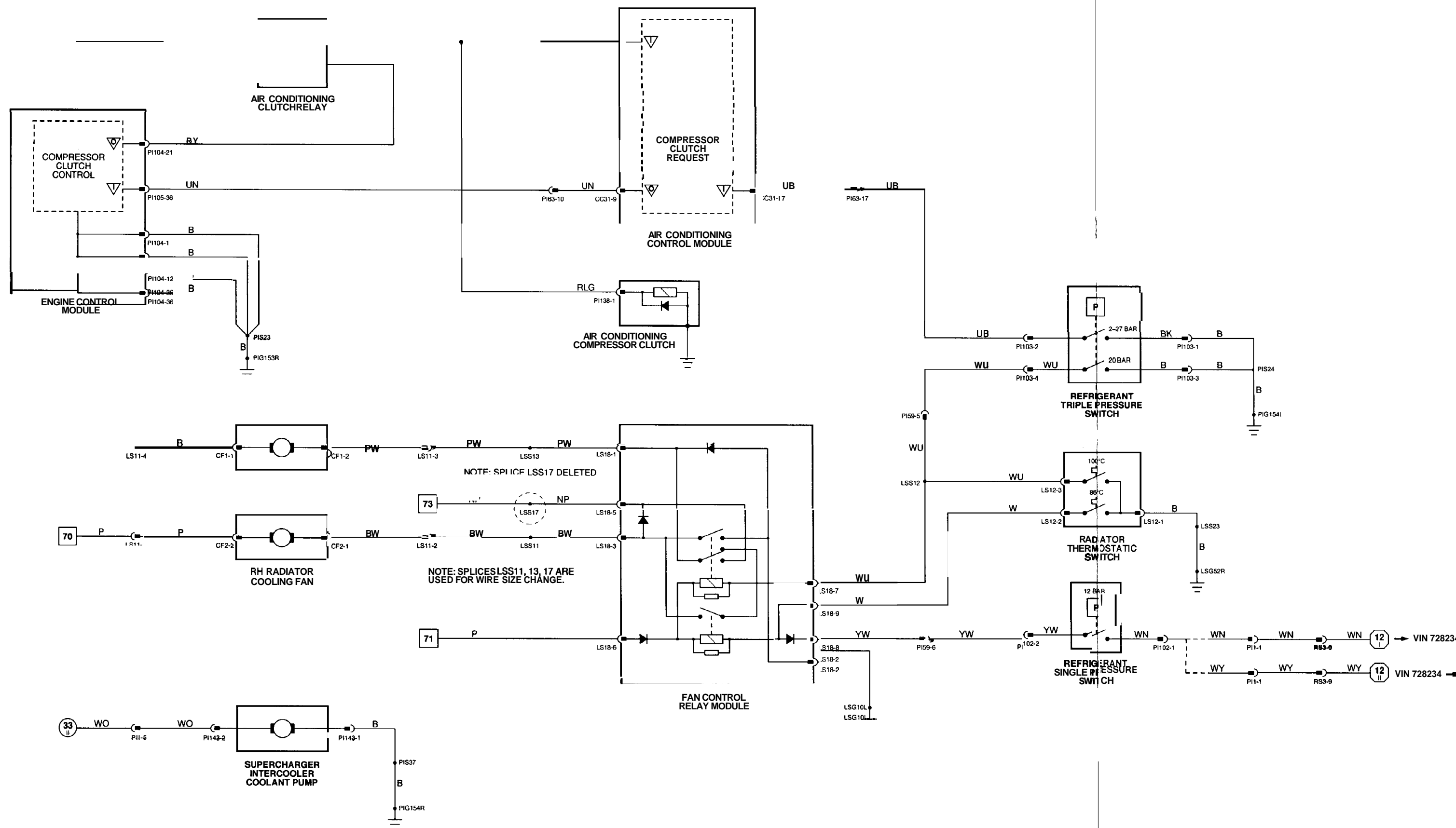

NOTE: SPLICE LSS17 DELETED

NOTE: SPLICES LSS11, 13, 17 ARE USED FOR WIRE SIZE CHANGE.

CONTROL MODULE PIN OUT INFORMATION

AIR CONDITIONING CONTROL MODULE

Pin	Description	Active	Inactive
I CC28-1	COMPRESSOR CLUTCH ON SIGNAL	B+	GROUND
O CC31-9	COMPRESSOR CLUTCH REQUEST	GROUND	B+
I CC31-17	REFRIGERANT TRIPLE PRESSURE SWITCH - 4.0L REFRIGERANT DUAL PRESSURE SWITCH - V12	GROUND	B+

ENGINE CONTROL MODULE (V12)

Pin	Description	Active	Inactive
I P144-13	AIR CONDITIONING REQUEST	B+	GROUND
O P146-16	AIR CONDITIONING CLUTCH RELAY	GROUND	B+

**Fig. 07.2**

COMPONENTS

Component	Connector	Type	Color	Location	Access
AIR CONDITIONING COMPRESSOR CLUTCH AIR CONDITIONING CONTROL MODULE	P116	3-WAY JUNIOR TIMER	BLACK	A/C COMPRESSOR	A/C UNIT, RH SIDE
	CC28	26-WAY MULTILOCK 47	SLATE	A/C UNIT, RH SIDE	RH UNDERSCUTTLE
	CC29	18-WAY MULTILOCK 47	SLATE		
	CC30	12-WAY MULTILOCK 47	SLATE		
	CC31	122-WAY MULTILOCK 41	SLATE		
ENGINE CONTROL MODULE (V12)	P144	28-WAY MULTILOCK 040	SLATE	RH 'A' POST / 'A' POST TRIM	
	P145	6-WAY MULTILOCK 040	SLATE		
	P146	22-WAY MULTILOCK 040	SLATE		
	P147	34-WAY MULTILOCK 040	SLATE		
FAN CONTROL RELAY MODULE	LS18	8-WAY TRW	BLACK	BELOW LH HEADLAMPS	
RADIATOR COOLING FAN (LH)	CF1	12-WAY REINSHAGEN	BLACK	ENGINE BAY, FRONT	
RADIATOR COOLING FAN (RH)	CF2	12-WAY REINSHAGEN	BLACK	ENGINE BAY, FRONT	
RADIATOR THERMOSTATIC SWITCH	LS12	3-WAY JUNIOR TIMER	BLACK	RADIATOR, LOWER LH SIDE	
REFRIGERANT DUAL PRESSURE SWITCH	P154	(FLY LEAD) 12-WAY ECONOSEAL III LC	BLACK	ENGINE BAY, RH REAR	

RELAYS

Relay	Color	Stripe	Connector	Color	Location	Access
AIR CONDITIONING CLUTCH RELAY	BLACK	WHITE	P117	BLACK	RH ENGINE BAY	RELAYS

HARNESS-TO-HARNESS CONNECTORS

Connector	Type	Color	Location / Access
LS11	4-WAY ECONOSEAL III H C	BLACK	SPOILER, LH SIDE / SPOILER
PI61	13-WAY ECONOSEAL III LC	BLACK	RH AIR CLEANER
PI63	20-WAY MULTILOCK 040	BLACK	RH 'A' POST / 'A' POST TRIM

GROUNDS

Ground	Location	Type
LSG10L	LEFT FORWARD GROUND STUD	
LSG10R	LEFT FORWARD GROUND STUD	
LSG51R	LH BULKHEAD GROUND STUD	
LSG52R	LEFT FORWARD GROUND STUD	
PIG75R	RH 'A' POST GROUND STUD	
PIG77R	RIGHT FORWARD EMS GROUND STUD	

CONTROL MODULE PIN OUT INFORMATION (FOLD OUT PAGE)



The following symbols are used to represent values for Control Module Pin Out data:

- I Input
- O output
- SG Signal Ground
- D Serial and encoded communications
- B+ Battery voltage
- V Voltage (DC)
- Hz Frequency
- KHz Frequency x 1000
- MS Milliseconds
- MV Millivolts

CAUTION: The information on this data page is furnished to aid the user in understanding circuit operation. THIS INFORMATION SHOULD BE USED FOR REFERENCE ONLY.

NOTE: The values listed are approximately those that can be expected at the control module connector pins with all circuit connections made and all components connected and fitted. "Active" means a load is applied or a switch is ON; "Inactive" means a load is not applied or a switch is OFF.

REFER TO THE FRONT OF THE BOOK FOR ILLUSTRATIONS DETAILING THE LOCATION AND IDENTIFICATION OF COMPONENTS, RELAYS, CONNECTORS, HARNESSES, GROUNDS, VEHICLE CONTROL MODULES AND CONTROL MODULE PINS.

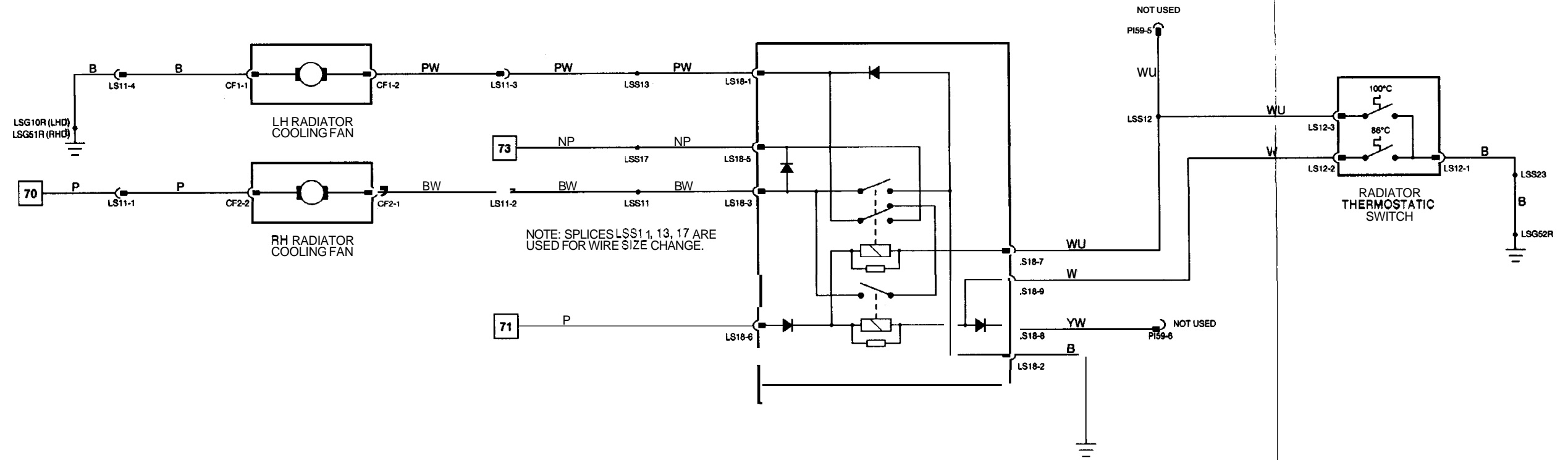
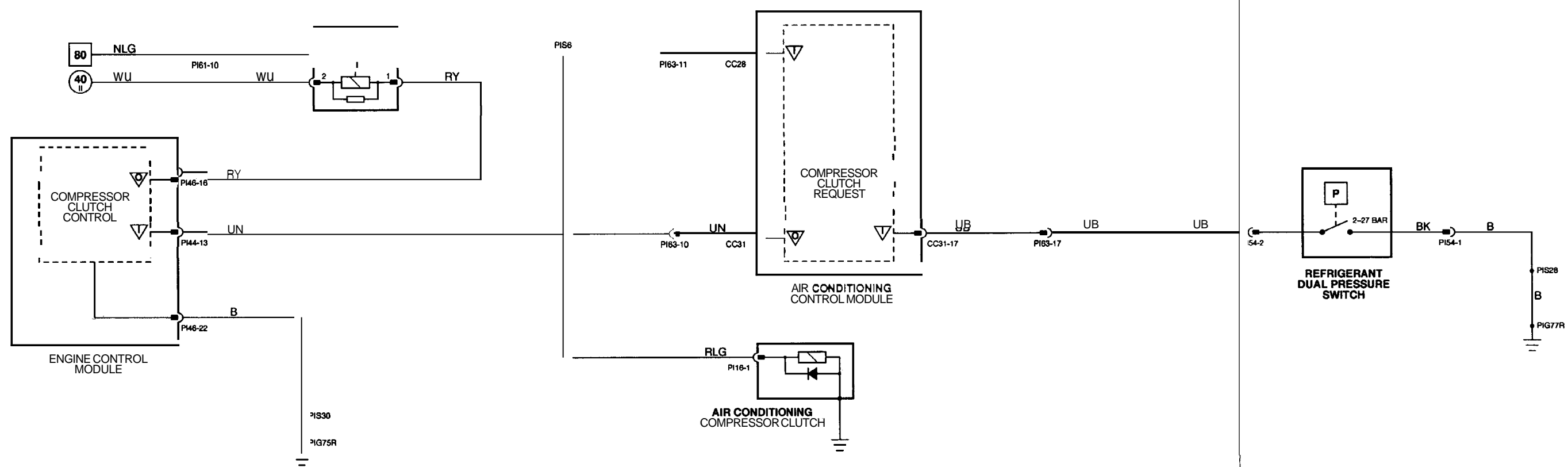

CONTROL MODULE PIN OUT INFORMATION

SPEED CONTROL CONTROL MODULE

Pin	Description	Active	Inactive
O FC17-3	DUMP VALVE, VACUUM PUMP & CONTROL VALVE POWER FEED	B+	B+
I FC17-6	VEHICLE SPEED INPUT	GROUND @ 10 MPH (16 KPH) = 20 Hz, 20 MPH (32 KPH) = 40 Hz	B+
I FC17-9	ANTI-LOCK TRACTION ACTIVE INHIBIT	GROUND	B+
O FC17-10	CONTROL VALVE GROUND	GROUND	GROUND
I FC17-12	SPEED CONTROL BRAKE / CLUTCH SWITCH	B+	GROUND
O FC17-14	WMP VALVE GROUND	GROUND	B+
I FC17-15	BRAKE LIGHT SWITCH	GROUND	B+
I FC17-17	SET / ACCELERATE RESUME SWITCH	SET ACCELERATE = 2.7 V, RESUME COAST = 5.5 V	B+ = P, R, N
I FC17-18	PARK / NEUTRAL SPEED CONTROL INHIBIT	GROUND = D, 3, 2	B+
O FC17-20	VACUUM PUMP GROUND	GROUND	B+

Fig. 08.1

COMPONENTS

Component	Connector / Type Color	Location / Access
BRAKE SWITCH	CA72 14-WAY MULTILOCK 070 / WHITE	DRIVER'S UNDERSCUTTLE
CLUTCH SWITCH (MANUAL TRANSMISSION)	CA73 / 2-WAY MULTILOCK 070 / YELLOW	ABOM CLUTCH PEDAL
CLUTCH SWITCH LINK (AUTOMATIC TRANSMISSION)	CA73 / 2-WAY MULTILOCK 070 / YELLOW	DRIVER'S UNDERSCUTTLE
DUMP VALVE	LS22 / 2-WAY ECONOSEAL III LC BLACK	BELOW LH FRONT RELAYS
SPEED CONTROL CONTROL MODULE	FC17 / 20-WAY PCB / BLACK	DRIVER'S UNDERSCUTTLE
SPEED CONTROL BRAKE SWITCH	CA72 / CWAY MULTILOCK 070 / WHITE	DRIVER'S UNDERSCUTTLE
SPEED CONTROL SWITCHES	FC18 / 16-WAY MULTILOCK MO BLACK	FASCIA SWITCH PACK
VACUUM PUMP AND CONTROL VALVE	LS23 13-WAY SPEED CONTROL BLACK	ENGINE BAY, LH FRONT

HARNESS-TO-HARNESS CONNECTORS

Connector	Type Color	Location / Access
CC3	20-WAY MULTILOCK MO / BLACK	CENTER CONSOLE / CENTER CONSOLE GLOVE BOX
FC5	THROUGH-PANEL (48 MICRO / 6) BLACK	LH FASCIA END PANEL / OUTER AIR VENT
FC7	THROUGH-PANEL (48 MICRO / 6) BLACK	PASSENGER'S UNDERSCUTTLE
LS3	THROUGH-PANEL (48 MICRO / 6) BLACK	LH 'A' POST / 'A' POST PANEL

GROUNDS

Ground	Location Type
CAG30R	LH 'A' POST GROUND SCREW
CAG33R	RH HEELBOARD GROUND SCREW
FCG26L	LH CONSOLE GROUND S N D

CONTROL MODULE PIN OUT INFORMATION (FOLD OUT PAGE)



The following symbols are used to represent values for Control Module Pin Out data:

I	Input	B+	Battery voltage
O	Output	V	Voltage (DC)
SG	Signal Ground	Hz	Frequency
D	Serial and encoded communications	KHz	Frequency x 1000
		MS	Milliseconds
		MV	Millivolts

CAUTION: The information on this data page is furnished to aid the user in understanding circuit operation. THIS INFORMATION SHOULD BE USED FOR REFERENCE ONLY.

NOTE: The values listed are approximately those that can be expected at the control module connector pins with all circuit connections made and all components connected and fixed. "Active" means a load is applied or a switch is ON; "Inactive" means a load is not applied or a switch is OFF.

REFER TO THE FRONT OF THE BOOK FOR ILLUSTRATIONS DETAILING THE LOCATION AND IDENTIFICATION OF COMPONENTS, RELAYS, CONNECTORS, HARNESES, GROUNDS, VEHICLE CONTROL MODULES AND CONTROL MODULE PINS.

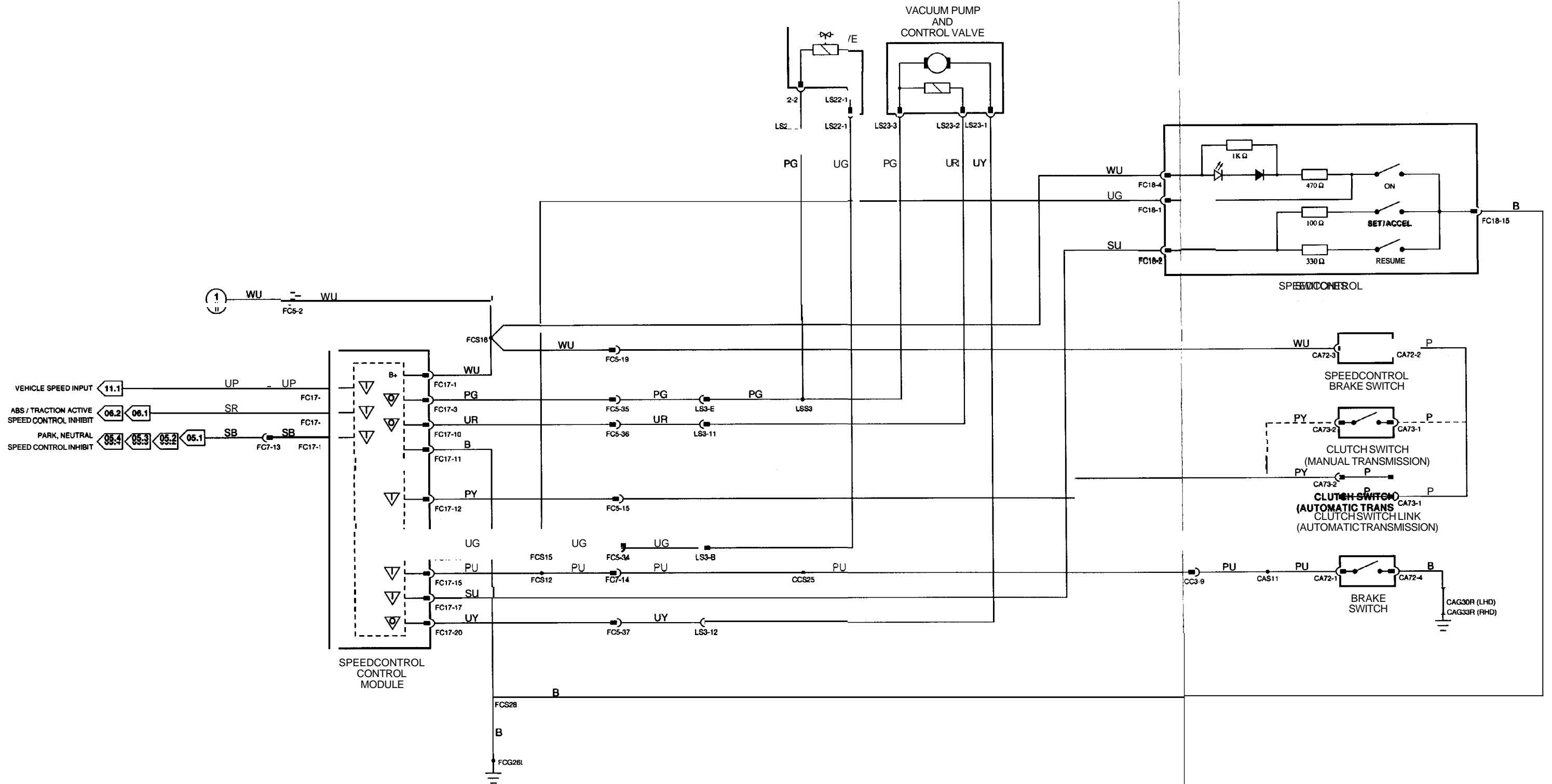

**CONTROL MODULE PIN OUT INFORMATION**

**BODY PROCESSOR MODULE**

Pin	Description	Active	Inactive
FC1-14	LH PILOT BEAM, SIDE LAMPS AND TAIL LAMPS ON	GROUND	B+
FC1-18	FRONT FOG LAMPS AND STATE LAMP ON	GROUND	B+
FC1-29	LH DIPPED BEAM ON	GROUND	B+
FC1-32	HEADLAMP MAIN BEAM INDICATOR	GROUND	B+
FC1-35	LH MAIN BEAM ON	GROUND	B+
FC1-39	RH DIPPED BEAM ON	GROUND	B+
FC1-41	RH MAIN BEAM ON	GROUND	B+
FC2-3	SIDE LAMPS ON	GROUND	B+
FC2-6	HEADLAMP CONVENIENCE	GROUND PULSE	B+
FC2-31	IGNITION SWITCHED GROUND	GROUND	B+
FC2-37	HEADLAMP FLASH SWITCH	GROUND	B+
FC2-40	HEADLAMPSON	GROUND	B+
FC2-43	FRONT FOG LAMPS	GROUND	B+

**LH FRONT LIGHTING CONTROL MODULE**

Pin	Description	Active	Inactive
LS30-7	IGNITION SWITCHED POWER	B+	GROUND

**RH FRONT LIGHTING CONTROL MODULE**

Pin	Description	Active	Inactive
RS30-7	IGNITION SWITCHED POWER	B+	GROUND

**COMPONENTS**

Component	Connector	Type	Color	Location / Access
BODY PROCESSOR MODULE			'48-WAY PCB SIGNAL / YELLOW '48-WAY PCB SIGNAL / BLACK '6-WAY PCB SIGNAL / BLACK	PASSENGERS UNDERSCUTTLE
FOG LAMP - LH	BL4	2-WAY JUNIOR TIMER	BLACK	LH REAR LAMP UNIT
FOG LAMP - RH	BR4	2-WAY JUNIOR TIMER	BLACK	RH REAR LAMP UNIT
HEADLAMP FLASH SWITCH (COLUMN SWITCH GEAR)	SC3	16-WAY MULTILOCK	070 WHITE	STEERING COLUMN COVER
HEADLAMP - LH	LS38	6-WAY ECONOSEAL III	LC/BLACK	LH HEADLAMP
HEADLAMP - RH	RS38	16-WAY ECONOSEAL III	LC/BLACK	RH HEADLAMP
LIGHTING CONTROL MODULE - LH FRONT	LS13	15-WAY JUNIOR TIMER	BROWN	ENGINE BAY, LH FRONT
LIGHTING CONTROL MODULE - RH FRONT	LS30	15-WAY JUNIOR TIMER	BLACK	ENGINE BAY, RH FRONT
LIGHTING SWITCHES	RS13	115-WAY JUNIOR TIMER	BROWN	FASCIA SWITCHPACK
	RSM	15-WAY JUNIOR TIMER	BLACK	
	FC12	16-WAY MULTILOCK	040 BLUE	

**HARNESSTO-HARNESCONNECTORS**

Connector	Type / Color	Location / Access
BL1	13-WAY ECONOSEAL III LC / BLACK	LH FRONT WHEEL ARCH LINER SPOILER AND SPOILER TRAY
BR1	13-WAY ECONOSEAL III LC / BLACK	RH FRONT WHEEL ARCH LINER SPOILER AND SPOILER TRAY
CC3	20-WAY MULTILOCK 040 / BLACK	CENTER CONSOLE CENTER CONSOLE GLOVE BOX
FC4	20-WAY MULTILOCK 040 / BLUE	DRIVER'S UNDERSCUTTLE
FC5	THROUGH-PANEL (48 MICRO / 6) / BLACK	LH FASCIA END PANEL / OUTER AIR VENT
FC6	THROUGH-PANEL (48 MICRO / 6) / BLACK	RH FASCIA END PANEL / OUTER AIR VENT
FC7	THROUGH-PANEL (48 MICRO / 6) / BLACK	PASSENGER'S UNDERSCUTTLE
FC16	20-WAY MULTILOCK 040 / BLACK	PASSENGERS UNDERSCUTTLE
LS3	THROUGH-PANEL (48 MICRO / 6) / BLACK	LH 'A' POST / 'A' WST PANEL
RS3	THROUGH-PANEL (48 MICRO / 6) / BROWN	RH 'A' POST / 'A' WST PANEL

**GROUNDS**

Ground	Location / Type
FCG15L	LH CONSOLE GROUNDS N D
LSG19R	LH BULKHEAD GROUND STUD
LSG52L	LEFT FORWARD GROUND STUD
RSGW	RIGHT FORWARD GROUND STUD
RSG41L	RIGHT FORWARD GROUND STUD
RSG41R	RIGHT FORWARD GROUND STUD
RSG42R	RH BULKHEAD GROUND STUD

**CONTROL MODULE PIN OUT INFORMATION (FOLD OUT PAGE)**



The following symbols are used to represent values for Control Module Pin Out data:

<b>I</b> Input	<b>B+</b> Battery voltage
<b>O</b> Output	<b>V</b> Voltage (DC)
<b>SG</b> Signal Ground	<b>Hz</b> Frequency
<b>D</b> Serial and encoded communications	<b>KHz</b> Frequency x 1000
	<b>MS</b> Milliseconds
	<b>MV</b> Millivolts

CAUTION: The information on this data page is furnished to aid the user in understanding circuit operation. THIS INFORMATION SHOULD BE USED FOR REFERENCE ONLY.

NOTE: The values listed are approximately those that can be expected at the control module connector pins with all circuit connections made and all components connected and fitted. "Active" means a load is applied or a switch is ON; "Inactive" means a load is not applied or a switch is OFF.

REFER TO THE FRONT OF THE BOOK FOR ILLUSTRATIONS DETAILING THE LOCATION AND IDENTIFICATION OF COMPONENTS, RELAYS, CONNECTORS, HARNESSES, GROUNDS, VEHICLE CONTROL MODULES AND CONTROL MODULE PINS.



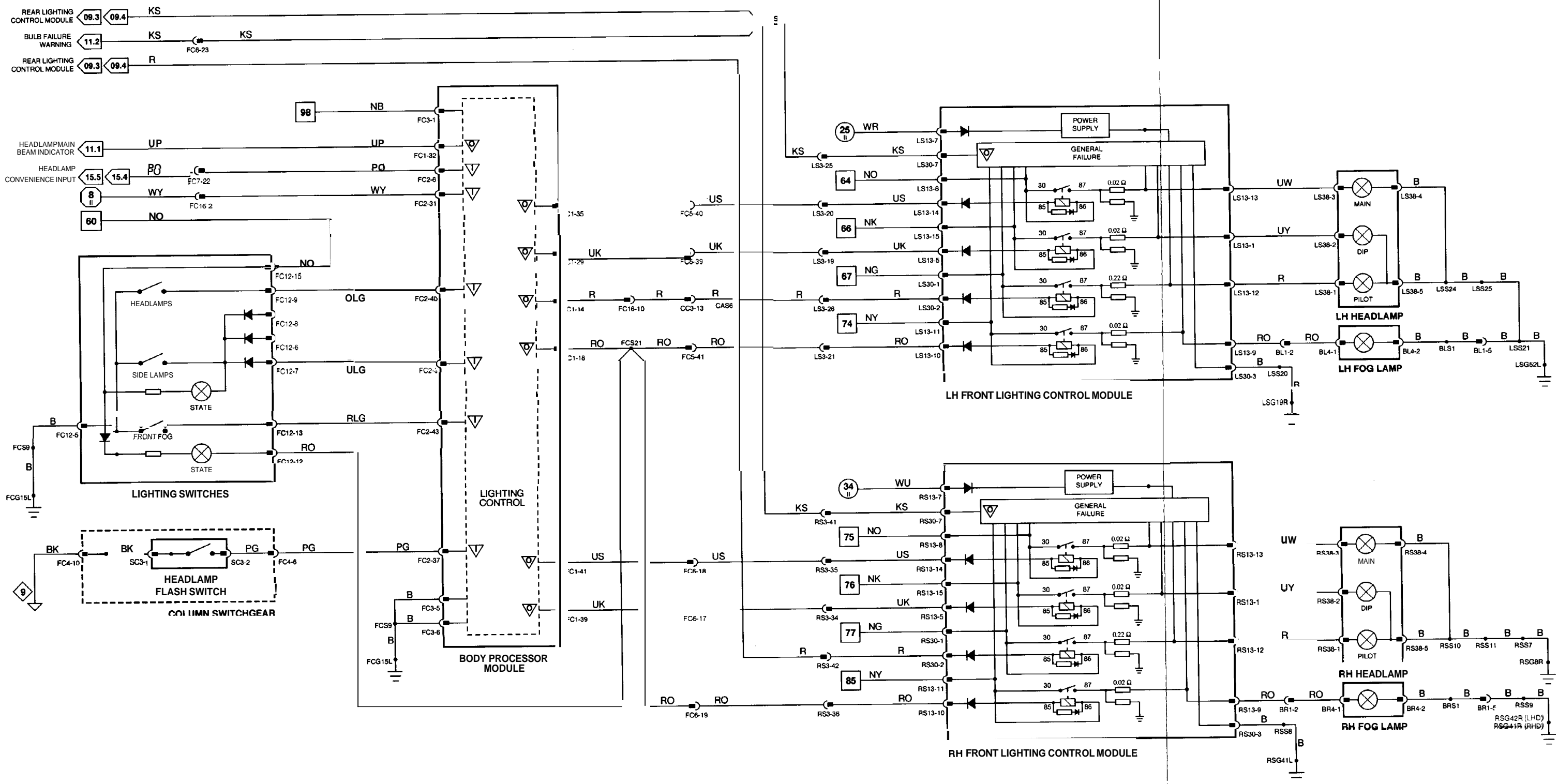

CONTROL MODULE PIN OUT INFORMATION

BODY PROCESSOR MODULE

Pin	Description	Active	Inactive
O FC1-14	LH PILOT BEAM, SIDE LAMPS AND TAIL LAMPS ON	GROUND	B+
O FC1-18	FRONT FOG LAMPS AND STATE LAMP ON	GROUND	B+
O FC1-29	LH DIPPED BEAM ON	GROUND	B+
O FC1-32	HEADLAMP MAIN BEAM INDICATOR	GROUND	B+
O FC1-35	LH MAIN BEAM ON	GROUND	B+
O FC1-39	RH DIPPED BEAM ON	GROUND	B+
O FC1-41	RH MAIN BEAM ON	GROUND	B+
I FC2-3	SIDE LAMPS ON	GROUND	B+
I FC2-6	HEADLAMP CONVENIENCE	GROUND PULSE	B+
I FC2-31	IGNITION SWITCHED GROUND	GROUND	B+
I FC2-37	HEADLAMP FLASH SWITCH	GROUND	B+
I FC2-40	HEADLAMPS ON	GROUND	B+
I FC2-43	FRONT FOG LAMPS	GROUND	B+

LH FRONT LIGHTING CONTROL MODULE

Pin	Description	Active	Inactive
O LS30-7	IGNITION SWITCHED POWER	B+	GROUND

RH FRONT LIGHTING CONTROL MODULE

Pin	Description	Active	Inactive
O RSM-7	IGNITION SWITCHED POWER	B+	GROUND

The following symbols are used to represent values for Control Module Pin Out data:

I Input	B+ Battery voltage
O output	V Voltage (DC)
SG Signal Ground	Hz Frequency
D Serial and encoded communications	KHz Frequency x 1000
	MS Milliseconds
	MV Millivolts

CAUTION: The information on this data page is furnished to aid the user in understanding circuit operation. THIS INFORMATION SHOULD BE USED FOR REFERENCE ONLY.

NOTE: The values listed are approximately those that can be expected at the control module connector pins with all circuit connections made and all components connected and fitted. "Active" means a load is applied or a switch is ON; "Inactive" means a load is not applied or a switch is OFF.

Fig. 09.2

COMPONENTS

Component	Connector / Type / Color	Location Access
BODY PROCESSOR MODULE	FC1 148-WAY PCB SIGNAL / YELLOW FC2 / 48-WAY PCB SIGNAL / BLACK FC3 / 6-WAY PCB SIGNAL / BLACK	PASSENGERS UNDERSCUTTLE
FOG LAMP - LH	BL4 / 2-WAY JUNIOR TIMER / BLACK	LH REAR LAMP UNIT
FOG LAMP - RH	BR4 / 2-WAY JUNIOR TIMER / BLACK	RH REAR LAMP UNIT
HEADLAMP FLASH SWITCH (COLUMN SWITCH GEAR)	SC3 / 6-WAY MULTILOCK 070 / WHITE	STEERING COLUMN COVER
HEADLAMP - LH	LS38 / 6-WAY ECONOSEAL III LC / BLACK	LH HEADLAMP
HEADLAMP - RH	RS38 / 6-WAY ECONOSEAL III LC / BLACK	RH HEADLAMP
LIGHTING CONTROL MODULE - LH FRONT	LS13 / 15-WAY JUNIOR TIMER / BROWN LS30 / 115-WAY JUNIOR TIMER / BLACK	ENGINE BAY, LH FRONT
LIGHTING CONTROL MODULE - RH FRONT	RS13 / 15-WAY JUNIOR TIMER / BROWN RS30 / 115-WAY JUNIOR TIMER / BLACK	ENGINE BAY, RH FRONT
LIGHTING SWITCHES	FC12 116-WAY MULTILOCK 040 / BLUE	FASCIA SWITCH PACK
SIDE MARKER LAMP - LH	BL5 / 2-WAY JUNIOR TIMER / BLACK	LH FRONT LAMP UNIT
SIDE MARKER LAMP - RH	BR5 / 2-WAY JUNIOR TIMER / BLACK	RH FRONT LAMP UNIT

HARNESSTO-HARNESSCONNECTORS

Connector	Type Color	Location Access
BL1	13-WAY ECONOSEAL III LC / BLACK	LH FRONT WHEEL ARCH LINER / SPOILER AND SPOILER TRAY
BR1	13-WAY ECONOSEAL III LC / BLACK	RH FRONT WHEEL ARCH LINER / SPOILER AND SPOILER TRAY
CC3	20-WAY MULTILOCK 040 / BLACK	CENTER CONSOLE / CENTER CONSOLE GLOVE BOX
FC4	20-WAY MULTILOCK 040 / BLUE	DRIVERS UNDERSCUTTLE
FC5	THROUGH-PANEL (48 MICRO / 6) / BLACK	LH FASCIA END PANEL / OUTER AIR VENT
FC6	THROUGH-PANEL (48 MICRO / 6) / BLACK	RH FASCIA END PANEL / OUTER AIR VENT
FC7	THROUGH-PANEL (48 MICRO / 6) / BLACK	PASSENGERS UNDERSCUTTLE
FC16	20-WAY MULTILOCK 040 / BLACK	PASSENGER'S UNDERSCUTTLE
LS3	THROUGH-PANEL (48 MICRO / 6) / BLACK	LH 'A' POST / 'A' POST PANEL
RS3	THROUGH-PANEL (48 MICRO / 6) / BROWN	RH 'A' POST / 'A' POST PANEL

GROUNDS

Ground	Location Type
FCG15L	LH CONSOLE GROUND STUD
LSG19R	LH BULKHEAD GROUND STUD
LSG52L	LEFT FORWARD GROUND STUD
RSGBR	RIGHT FORWARD GROUND STUD
RSG41L	RIGHT FORWARD GROUND STUD
RSG41R	RIGHT FORWARD GROUND STUD
RSG42R	RH BULKHEAD GROUND STUD

CONTROL MODULE PIN OUT INFORMATION (FOLD OUT PAGE)



REFER TO THE FRONT OF THE BOOK FOR ILLUSTRATIONS OF THE LOCATION AND IDENTIFICATION OF COMPONENTS, RELAYS, DRIVERS HARNESSES, GROUNDS, VEHICLE CONTROL MODULES AND CONTROL MODULE PINS.

DATE OF ISSUE: JANUARY 1995

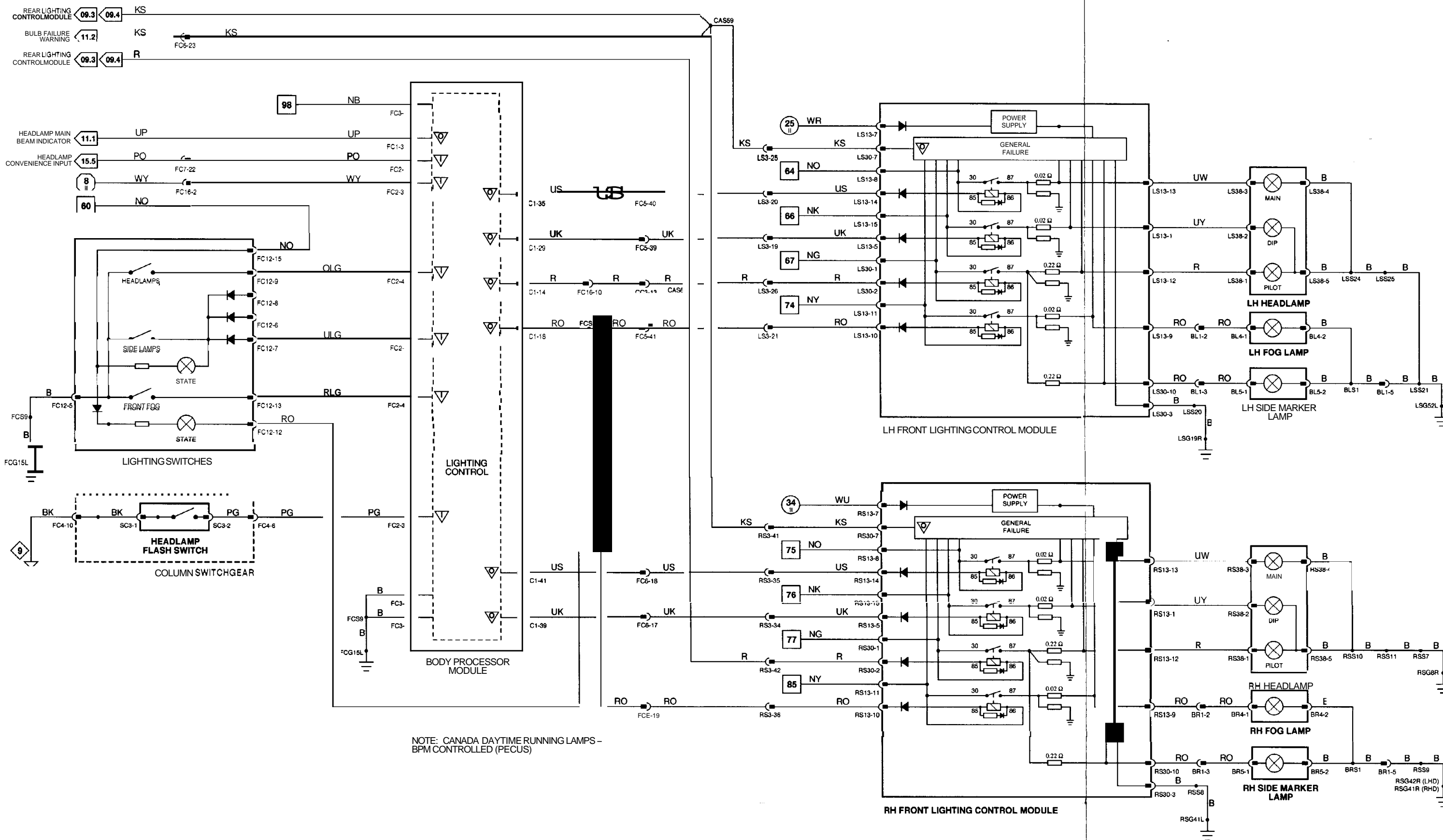

CONTROL MODULE PIN OUT INFORMATION

BODY PROCESSOR MODULE

Pin	Description	Active	Inactive
FC1-14	LH PILOT BEAM, SIDE LAMPS AND TAIL LAMPS ON	GROUND	B+
FC1-45	FOG LAMP BULB FAIL OVERRIDE (FINLAND)	GROUND	B+
FC1-47	REAR FOG LAMPS AND STATE LAMP ON	GROUND	B+
FC2-3	SIDE LAMPS ON	GROUND	B+
FCZ31	IGNITION SWITCHED GROUND	GROUND	B+
FC2-45	REAR FOG GUARD LAMP REQUEST	GROUND	B+

REAR LIGHTING CONTROL MODULE

Pin	Description	Active	Inactive
BT21-16	GENERAL BULB FAILURE	GROUND	B+

Fig. 09.3

COMPONENTS

Component	Connector / Type   Color	Location / Access
BODY PROCESSOR MODULE	FC1 / 48-WAY PCB SIGNAL / YELLOW FC2 / 48-WAY PCB SIGNAL   BLACK FC3 / 6-WAY PCB SIGNAL / BLACK	PASSENGERS UNDERSCUTTLE
LIGHTING CONTROL MODULE - REAR	BT20   18-WAY MULTILOCK 070   WHITE BT21 120-WAY MULTILOCK 040 / BLACK	TRUNK ELECTRICAL CARRIER
LIGHTING SWITCHES	FC12 / 16-WAY MULTILOCK 040 / BLUE	FASCIA SWITCH PACK
NUMBER PLATE LAMP - LH	BT27 / 2-WAY POSILOCK   BLACK	TRUNK LID / TRUNK LID TRIM
NUMBER PLATE LAMP - RH	BT11   2-WAY POSILOCK / BLACK	TRUNK LID / TRUNK LID TRIM
SIDE MARKER LAMP - LH	SR1-L 12-WAY JUNIOR TIMER   BLACK	LH FRONT LAMP UNIT
SIDE MARKER LAMP - RH	SR1-R 12-WAY JUNIOR TIMER / BLACK	RH FRONT LAMP UNIT
TAIL LAMP UNIT - LH	TL4 / 7-WAY JUNIOR TIMER   BLACK	LH REAR / TRUNK TRIM
TAIL LAMP UNIT - RH	TL3 17-WAY JUNIOR TIMER / BLACK	RH REAR / TRUNK TRIM

HARNESS-TO-HARNESS CONNECTORS

Connector	Type   Color	Location / Access
BT4	THROUGH-PANEL (48 MICRO / 6)   BLACK	PARCEL SHELF / FUEL TANK TRIM
BT50	18-WAY MULTILOCK 070   WHITE	TRUNK FLOOR TRIM / BATTERY COVER
CC3	20-WAY MULTILOCK 040   BLACK	CENTER CONSOLE / CENTER CONSOLE GLOVE BOX
FC5	THROUGH-PANEL (48 MICRO / 6) / BLACK	LH FASCIA END PANEL / OUTER AIR VENT
FC6	THROUGH-PANEL (48 MICRO / 6)   BLACK	RH FASCIA END PANEL / OUTER AIR VENT
FC16	20-WAY MULTILOCK 040 / BLACK	PASSENGERS UNDERSCUTTLE
TL5	2-WAY MULTILOCK 040 / GREEN	TRUNK LID / TRUNK LID TRIM
TL6	2-WAY MULTILOCK 040 / GREEN	TRUNK LID / TRUNK LID TRIM

GROUNDS

Ground	Location / Type
BTG48L	REAR TRUNK GROUND STUD
BTG48R	REAR TRUNK GROUND STUD
BTG49L	REAR TRUNK GROUND STUD
FCG15L	LH CONSOLE GROUND STUD

CONTROL MODULE PIN OUT INFORMATION (FOLD OUT PAGE)



The following symbols are used to represent values for Control Module Pin Out data:

I	Input	B+	Battery voltage
O	Output	V	Voltage (DC)
SG	Signal Ground	Hz	Frequency
D	Serial and encoded communications	KHz	Frequency x 1000
		MS	Milliseconds
		MV	Millivolts

CAUTION The information on this data page is furnished to aid the user in understanding circuit operation. THIS INFORMATION SHOULD BE USED FOR REFERENCE ONLY.

NOTE: The values listed are approximately those that can be expected at the control module connector pins with all circuit connections made and all components connected and fitted. "Active" means a load is applied or a switch is ON; "Inactive" means a load is not applied or a switch is OFF.

REFER TO THE FRONT OF THE BOOK FOR ILLUSTRATIONS DETAILING THE LOCATION AND IDENTIFICATION OF COMPONENTS, RELAYS, CONNECTORS, HARNESSES, GROUNDS, VEHICLE CONTROL MODULES AND CONTROL MODULE PINS.

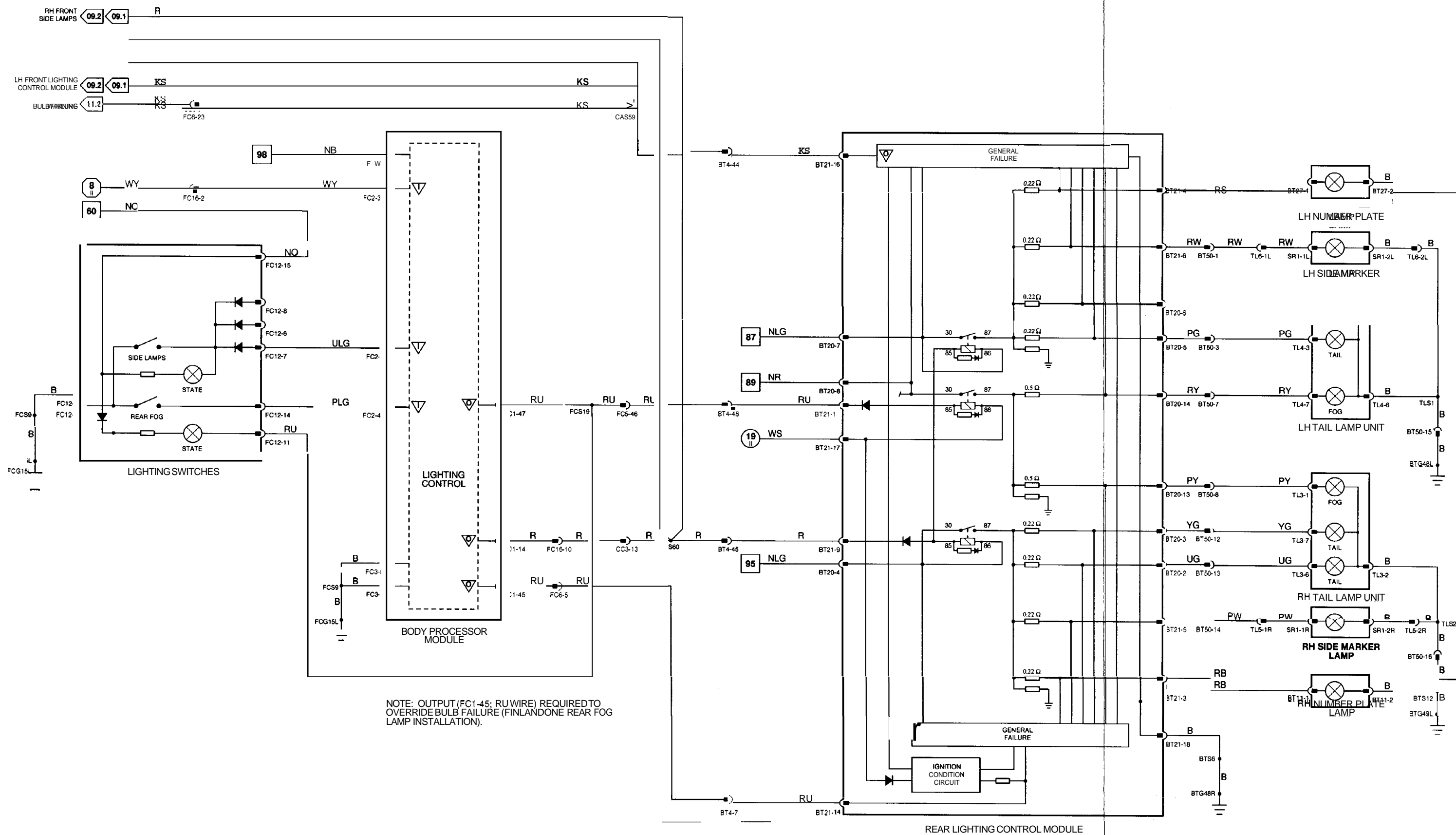

CONTROL MODULE PIN OUT INFORMATION

REAR LIGHTING CONTROL MODULE

Pin	Description	Active	Inactive
0	BT21-16 GENERAL BULB FAILURE	GROUND	B+

**Fig. 09.4**

COMPONENTS

Component	Connector	Type	Color	Location / Access
BRAKE SWITCH	CA72	4-WAY MULTILOCK	070 / WHITE	DRIVERS UNDERSCUTTLE
DIODE (BT51) - HIGH MOUNTED STOP LAMP	BT51	DIODE	BLACK	TRUNK HARNESS, ADJACENT TO BATTERY
HIGH MOUNTED STOP LAMP	CA35	3-WAY MT EDGE	SLATE	RH FLOOR PANEL BACKLIGHT
LIGHTING CONTROL MODULE - REAR	BT20	18-WAY MULTILOCK	070 / WHITE	TRUNK ELECTRICAL CARRIER
	BT21	120-WAY MULTILOCK	040 / BLACK	
LINEAR GEAR POSITION SWITCHES	CC21	120-WAY MULTILOCK	040 / BLACK	'J' GATE
REVERSE SWITCH (AJ16 MANUAL1	CC45	2-WAY SUMITOMO	WHITE	CENTER CONSOLE TRANSMISSION TUNNEL
ROTARY SWITCH	GB1	FLY LEAD	8-WAY MULTILOCK	0701 WHITE
	GB2	FLY LEAD	12-WAY MULTILOCK	040 BLACK
TAIL LAMP UNIT - LH	TL4	7-WAY JUNIOR TIMER	BLACK	LH REAR / TRUNK TRIM
TAIL LAMP UNIT - RH	TL3	7-WAY JUNIOR TIMER	BLACK	RH REAR / TRUNK TRIM

RELAYS

Relay	Color / Stripe	Connector / Color	Location / Access
HIGH MOUNTED STOP LAMP RELAY	BLACK / VIOLET	BT13 / RED	TRUNK ELECTRICAL CARRIER

HARNESS-TO-HARNESS CONNECTORS

Connector	Type / Color	Location / Access
BT4	THROUGH-PANEL (48 MICRO / 6) BLACK	PARCEL SHELF / FUEL TANK TRIM
BT50	18-WAY MULTILOCK 070 / WHITE	TRUNK FLOOR TRIM / BATTERY COVER
CC3	20-WAY MULTILOCK 040 / BLACK	CENTER CONSOLE / CENTER CONSOLE GLOVE BOX
FC6	THROUGH-PANEL (48 MICRO / 6) / BLACK	RH FASCIA END PANEL / OUTER AIR VENT

GROUNDS

Ground	Location / Type
BTG48L	REAR TRUNK GROUND STUD
BTG48R	REAR TRUNK GROUND STUD
BTG49L	REAR TRUNK GROUND STUD
CAG30R	LH 'A' POST GROUND SCREW
CAG33R	RH HEELBOARD GROUND SCREW
CAG92R	RH HEELBOARD GROUND SCREW
CCG51L	CENTER CONSOLE GROUND STUD
CCG51R	CENTER CONSOLE GROUND STUD
CCG8L	CENTER CONSOLE GROUND STUD

CONTROL MODULE PIN OUT INFORMATION (FOLD OUT PAGE)



The following symbols are used to represent values for Control Module Pin Out data:

- I Input
- O output
- SG Signal Ground
- D Serial and encoded communications
- B+ Battery voltage
- V Voltage (DC)
- Hz Frequency
- KHz Frequency x 1000
- MS Milliseconds
- MV Millivolts

CAUTION The information on this data page is furnished to aid the user in understanding circuit operation. THIS INFORMATION SHOULD BE USED FOR REFERENCE ONLY.

NOTE: The values listed are approximately those that can be expected at the control module connector pins with all circuit connections made and all components connected and fixed. "Active" means a load is applied or a switch is ON; "Inactive" means a load is not applied or a switch is OFF.

REFER TO THE FRONT OF THE BOOK FOR ILLUSTRATIONS DETAILING THE LOCATION AND IDENTIFICATION OF COMPONENTS, RELAYS, CONNECTORS, HARNESES, GROUNDS, VEHICLE CONTROL MODULES AND CONTROL MODULE PINS.

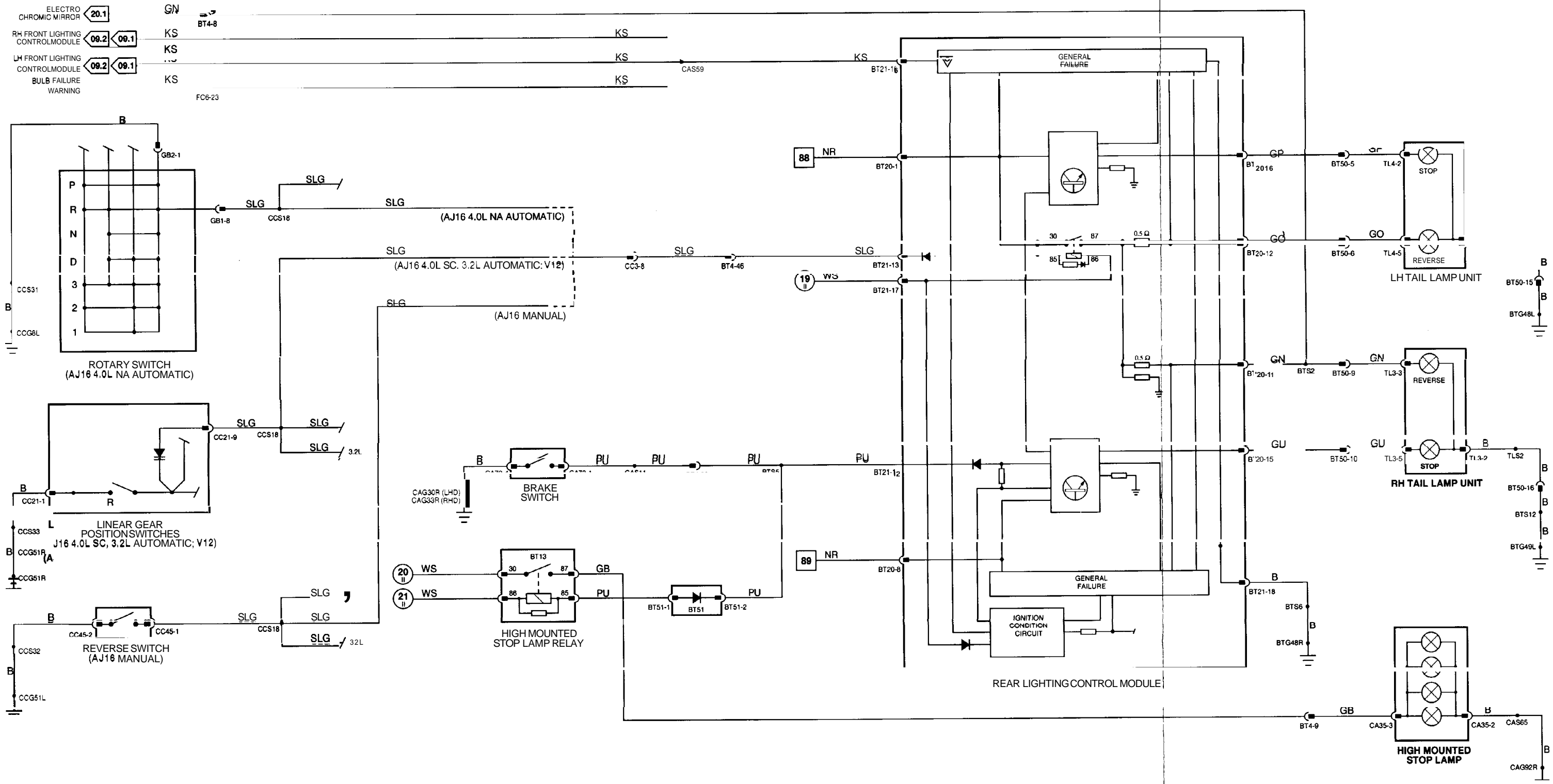

CONTROL MODULE PIN OUT INFORMATION

BODY PROCESSOR MODULE

Pin	Description	Active	Inactive
0 FC1-17	LH DI INDICATOR	GROUND PULSE	B+
0 FC1-19	RH DI INDICATOR	GROUND PULSE	B+
0 FC1-38	HAZARD WARNING STATE LAMP	GROUND PULSE	B+
0 FC1-46	DI BULB FAIL WARNING LAMP	GROUND	B+
1 FC2-10	LH DI BULB FAILURE	GROUND	B+
1 FC2-18	RH DI REQUEST	GROUND	B+
1 FC2-27	HAZARD LAMPS REQUEST	GROUND	B+
1 FC2-31	IGNITION SWITCHED GROUND	GROUND	B+
1 FC2-34	RH DI FAILURE	GROUND	B+
1 FC2-42	RH GROUND DISCONNECT LOOP	GROUND	B+
1 FC2-44	LH GROUND DISCONNECT LOOP	GROUND	B+
1 FC2-46	LH DI REQUEST	GROUND	B+

LH FRONT LIGHTING CONTROL MODULE

Pin	Description	Active	Inactive
0 LSM-5	LH DI BULB FAILURE	GROUND	B+
0 LS30-7	IGNITION SWITCHED POWER	B+	GROUND

RH FRONT LIGHTING CONTROL MODULE

Pin	Description	Active	Inactive
0 RS30-5	RH DI BULB FAILURE	GROUND	B+
0 RS30-7	IGNITION SWITCHED POWER	B+	GROUND

REAR LIGHTING CONTROL MODULE

Pin	Description	Active	Inactive
0 BT21-7	RH DI BULB FAILURE	GROUND	B+
0 BT21-8	LH DI BULB FAILURE	GROUND	B+
0 BT21-16	GENERAL BULB FAILURE	GROUND	B+

Fig. 09.5

COMPONENTS

Component	Connector / Type / Color	Location / Access
BODY PROCESSOR MODULE	FC1 / 48-WAY PCB SIGNAL / YELLOW FC2 / 48-WAY PCB SIGNAL / BLACK FC3 / 6-WAY PCB SIGNAL / BLACK	PASSENGERS UNDERSCUTTLE
CENTER CONSOLE SWITCH PACK AND CLOCK	CC1 / 16-WAY MULTILOCK040 / BLACK	CENTER CONSOLE
DIODE (FC59) - RH DI INDICATOR	FC59 DIODE / BLACK	FASCIA HARNESS / INSTRUMENT PACU
DIODE (FC60) - LH DI INDICATOR	FCW / DIODE / BLACK	FASCIA HARNESS / INSTRUMENT PACK
DIRECTION INDICATOR SWITCHES (COLUMN SWITCHGEAR)	SC3 / 6-WAY MULTILOCK070 / WHITE	STEERING COLUMN / COVER
DIRECTION INDICATORS - LH	0L2 / 3-WAY JUNIOR TIMER / BLACK	LH FRONT / SPOILER
DIRECTION INDICATORS - RH	BR2 / 3-WAY JUNIOR TIMER / BLACK	RH FRONT / SPOILER
LIGHTING CONTROL MODULE - LH FRONT	LS13 / 15-WAY JUNIOR TIMER / BROWN LS30 / 15-WAY JUNIOR TIMER / BLACK	ENGINE BAY, LH FRONT
LIGHTING CONTROL MODULE - RH FRONT	RS13 / 15-WAY JUNIOR TIMER / BROWN RS30 / 15-WAY JUNIOR TIMER / BLACK	ENGINE BAY, RH FRONT
LIGHTING CONTROL MODULE - REAR	BT20 / 18-WAY MULTILOCK0701 WHITE BT21 / 20-WAY MULTILOCK040 / BLACK	TRUNK ELECTRICAL CARRIER
REPEATER - LH	LS17 / 2-WAY JUNIOR TIMER / BLACK	LH FRONT FENDER
REPEATER - RH	RS12 / 12-WAY JUNIOR TIMER / BLACK	RH FRONT FENDER
TAIL LAMP UNIT - LH	TL4 / 7-WAY JUNIOR TIMER / BLACK	LH REAR / TRUNK TRIM
TAIL LAMP UNIT - RH	TL3 / 7-WAY JUNIOR TIMER / BLACK	RH REAR / TRUNK TRIM

HARNESS-TO-HARNESS CONNECTORS

Connector	Type / Color	Location / Access
BL1	13-WAY ECONOSEAL III LC / BLACK	LH FRONT WHEEL ARCH LINER / SPOILER AND SPOILER TRAY
BR1	13-WAY ECONOSEAL III LC / BLACK	RH FRONT WHEEL ARCH LINER / SPOILER AND SPOILER TRAY
BT4	THROUGH-PANEL 146 MICRO / 6 / BLACK	PARCEL SHELF / FUEL TANK TRIM
BT50	18-WAY MULTILOCK0701 WHITE	TRUNK FLOOR TRIM / BATTERY COVER
FC16	20-WAY MULTILOCK040 / BLACK	PASSENGERS UNDERSCUTTLE
FC4	20-WAY MULTILOCK040 / BLUE	DRIVERS UNDERSCUTTLE
FC5	THROUGH-PANEL 148 MICRO / 6 / BLACK	LH FASCIA END PANEL / OUTER AIR VENT
FC6	THROUGH-PANEL 148 MICRO / 6 / BLACK	RH FASCIA END PANEL / OUTER AIR VENT
FC7	THROUGH-PANEL 148 MICRO / 6 / BLACK	PASSENGER'S UNDERSCUTTLE
LS3	THROUGH-PANEL 148 MICRO / 6 / BLACK	LH 'A' POST / 'A' POST PANEL
RS3	THROUGH-PANEL 148 MICRO / 6 / BROWN	RH 'A' POST / 'A' POST PANEL

GROUNDS

Ground	Location / Type
BTG48L	REAR TRUNK GROUND STUD
BTG48R	REAR TRUNK GROUND STUD
BTG49L	REAR TRUNK GROUND STUD
CCG51L	CENTER CONSOLE GROUND STUD
FCG15L	LH CONSOLE GROUND STUD
LSG19R	LH BULKHEAD GROUND STUD
LSG52L	LEFT FORWARD GROUND STUD
RS41L	RIGHT FORWARD GROUND STUD
RS41R	RIGHT FORWARD GROUND STUD
RS42R	RH BULKHEAD GROUND STUD

CONTROL MODULE PIN OUT INFORMATION (FOLD OUT PAGE)



The following symbols are used to represent values for Control Module Pin Out data:

- I Input
- O output
- SG Signal Ground
- D Serial and encoded communications
- B+ Battery voltage
- V Voltage (DC)
- Hz Frequency
- KHz Frequency x 1000
- MS Milliseconds
- MV Millivolts

CAUTION The information on this data page is furnished to aid the user in understanding circuit operation. THIS INFORMATION SHOULD BE USED FOR REFERENCE ONLY.

NOTE: The values listed are approximately those that can be expected at the control module connector pins with all circuit connections made and all components connected and fitted. "Active" means a load is applied or a switch is ON; "Inactive" means a load is not applied or a switch is OFF.

REFER TO THE FRONT OF THE BOOK FOR ILLUSTRATIONS OF THE LOCATION AND IDENTIFICATION OF COMPONENTS, RELAYS, CONNECTORS, HARNESSES, GROUNDS, VEHICLE CONTROL MODULES AND CONTROL MODULE PINS.



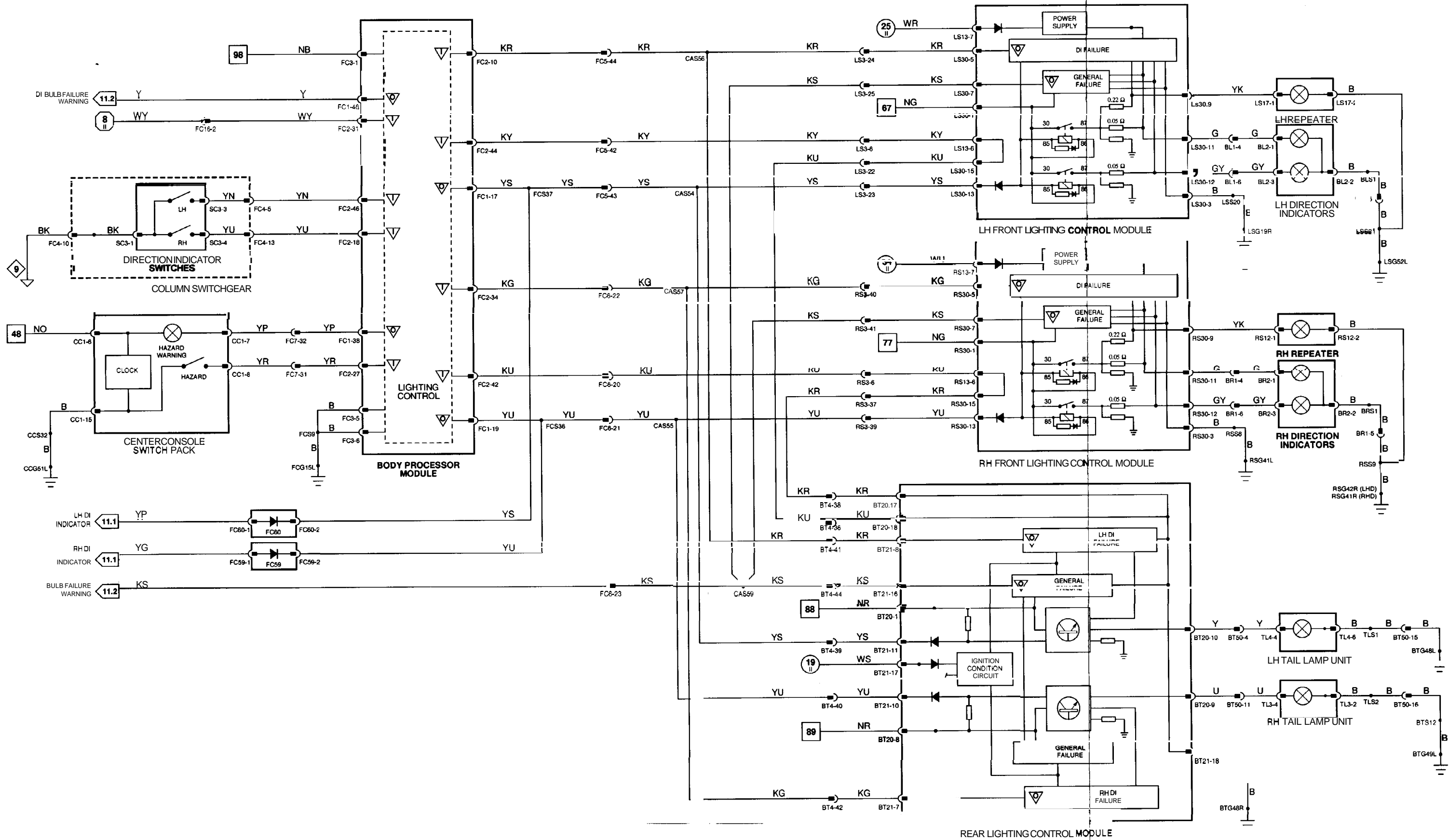

**Fig. 09.6****COMPONENTS****Component**

CENTER CONSOLE SWITCH PACK  
 HEADLAMP LEVELING ACTUATOR - LH  
 HEADLAMP LEVELING ACTUATOR - RH

**Connector / Type / Color**

CC1 16-WAY MULTILOCK MO BLACK  
 LS41 13-WAY GROTE AND HARTMAN / BLACK  
 RS22 13-WAY GROTE AND HARTMAN / BLACK

**Location / Access**

CENTER CONSOLE  
 LH HEADLAMP, REAR  
 RH HEADLAMP, REAR

**HARNESSTO-HARNESCONNECTORS****Connector****Type / Color**

CC3 20-WAY MULTILOCK MO BLACK  
 CC5 20-WAY MULTILOCK 040 GREEN  
 LS3 THROUGH-PANEL (48 MICRO / 6) / BLACK  
 RS3 THROUGH-PANEL (48 MICRO / 6) BROWN

**Location / Access**

CENTER CONSOLE / CENTER CONSOLE GLOVE BOX  
 CENTER CONSOLE / CENTER CONSOLE GLOVE BOX  
 LH 'A' POST / 'A' POST PANEL  
 RH 'A' POST / 'A' POST PANEL

**GROUNDS****Ground****Location / Type**

CCG51L CENTER CONSOLE GROUND STUD  
 LSG52L LEFT FORWARD GROUND STUD  
 RSG8R RIGHT FORWARD GROUND

REFER TO THE FRONT OF THE BOOK FOR ILLUSTRATIONS DETAILING THE LOCATION AND IDENTIFICATION OF COMPONENTS, RELAYS, CONNECTORS, HARNESS, GROUND STUDS, VEHICLE CONTROL MODULES AND CONTROL MODULE PINS.

DATE OF ISSUE: JANUARY 1995

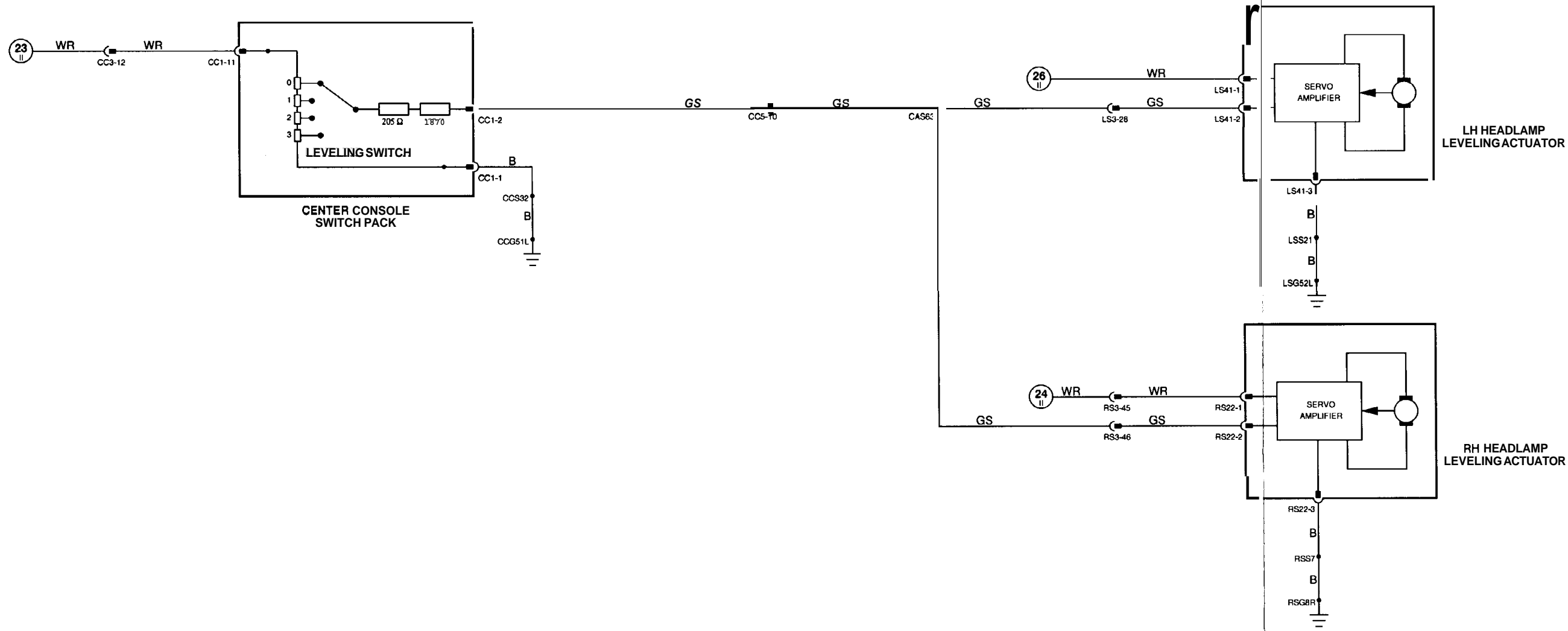

CONTROL MODULE PIN OUT INFORMATION

BODY PROCESSOR MODULE

Pin	Description	Active	Inactive
O FC1-18	FRONT FOG LAMPS AND STATE LAMP ON	GROUND	B+
O FC1-29	LH DIPPED BEAM ON	GROUND	B+
O FC1-32	HEADLAMP MAIN BEAM INDICATOR	GROUND	B+
O FC1-39	RH DIPPED BEAM ON	GROUND	B+
O FC1-41	MAIN BEAM ON	GROUND	B+
I FC2-3	SIDE LAMPS ON	GROUND	B+
I FC2-6	HEADLAMP CONVENIENCE	GROUND PULSE	B+
I FC2-31	IGNITION SWITCHED GROUND	GROUND	B+
I FC2-37	HEADLAMP FLASH SWITCH	GROUND	B+
I FC2-40	HEADLAMPS ON	GROUND	B+
I FC2-43	FRONT FOG LAMPS	GROUND	B+

Fig. 09.7

COMPONENTS

Component	Connector / Type / Color	Location / Access
BODY PROCESSOR MODULE	FC1 / 48-WAY PCB SIGNAL / YELLOW FC2 / 48-WAY PCB SIGNAL / BLACK FC3 / 6-WAY PCB SIGNAL / BLACK	PASSENGERS UNDERSCUTTLE
FOG LAMP - LH	BL4 / 2-WAY JUNIOR TIMER / BLACK	LH REAR LAMP UNIT
FOG LAMP - RH	BR4 / 2-WAY JUNIOR TIMER / BLACK	RH REAR LAMP UNIT
HEADLAMP FLASH SWITCH (COLUMN SWITCHGEAR)	SC3 / 6-WAY MULTILOCK 070 / WHITE	STEERING COLUMN / COVER
HEADLAMP - LH	LS38 / 6-WAY ECONOSEAL III LC / BLACK	LH HEADLAMP
HEADLAMP - RH	RS38 / 6-WAY ECONOSEAL III LC / BLACK	RH HEADLAMP
LIGHTING SWITCHES	FC12 / 16-WAY MULTILOCK 040 / BLUE	FASCIA SWITCH PACK
SIDE MARKER LAMP - LH (NAS ONLY)	BL5 / 2-WAY JUNIOR TIMER / BLACK	LH FRONT LAMP UNIT
SIDE MARKER LAMP - RH (NAS ONLY)	BR5 / 2-WAY JUNIOR TIMER / BLACK	RH FRONT LAMP UNIT

RELAYS

Relay	Color / Stripe	Connector / Color	Location / Access
DIP RELAY - LH	BLACK	LS54 / BLACK	ENGINE BAY, LH FRONT
DIP RELAY - RH	BLACK	RS47 / BLACK	ENGINE BAY, RH FRONT
FRONT FOG LAMP RELAY	BLACK	LS55 / BLACK	ENGINE BAY, LH FRONT
MAIN BEAM RELAY	BLACK	RS46 / BLACK	ENGINE BAY, RH FRONT

HARNESS-TO-HARNESS CONNECTORS

Connector	Type / Color	Location / Access
BL1	13-WAY ECONOSEAL III LC / BLACK	LH FRONT WHEEL ARCH LINER / SPOILER AND SPOILER TRAY
BR1	13-WAY ECONOSEAL III LC / BLACK	RH FRONT WHEEL ARCH LINER / SPOILER AND SPOILER TRAY
FC4	20-WAY MULTILOCK 040 / BLUE	DRIVERS UNDERSCUTTLE
FC5	THROUGH-PANEL (48 MICRO / 6) / BLACK	LH FASCIA END PANEL / OUTER AIR VENT
FC6	THROUGH-PANEL (48 MICRO / 6) / BLACK	RH FASCIA END PANEL / OUTER AIR VENT
FC7	THROUGH-PANEL (48 MICRO / 6) / BLACK	PASSENGERS UNDERSCUTTLE
FC16	20-WAY MULTILOCK 040 / BLACK	PASSENGERS UNDERSCUTTLE
LS3	THROUGH-PANEL (48 MICRO / 6) / BLACK	LH 'A' POST / 'A' POST PANEL
PI1	13-WAY ECONOSEAL III LC / WHITE	RH AIR CLEANER
PI59	13-WAY ECONOSEAL III LC / BLACK	LH AIR CLEANER
RS3	THROUGH-PANEL (48 MICRO / 6) / BROWN	RH 'A' POST / 'A' POST PANEL

GROUNDS

Ground	Location / Type
FCG15L	LH CONSOLE GROUND STUD
LSG52L	LEFT FORWARD GROUND STUD
RSG8R	RIGHT FORWARD GROUND STUD
RSG41R	RIGHT FORWARD GROUND STUD
RSG42R	RH BULKHEAD GROUND STUD

CONTROL MODULE PIN OUT INFORMATION (FOLD OUT PAGE)



The following symbols are used to represent values for Control Module Pin Out data:

I Input	B+ Battery voltage
O output	V Voltage (DC)
SG Signal Ground	Hz Frequency
D Serial and encoded communications	KHz Frequency x 1000
	MS Milliseconds
	MV Millivolts

CAUTION The information on this data page is furnished to aid the user in understanding circuit operation. THIS INFORMATION SHOULD BE USED FOR REFERENCE ONLY.

NOTE: The values listed are approximately those that can be expected at the control module connector pins with all circuit connections made and all components connected and fitted. "Active" means a load is applied or a switch is ON; "Inactive" means a load is not applied or a switch is OFF.

REFER TO THE FRONT OF THE BOOK FOR ILLUSTRATIONS DETAILING THE LOCATION AND IDENTIFICATION OF COMPONENTS, RELAYS, CONNECTORS, HARNESSES, GROUNDS, VEHICLE CONTROL MODULES AND CONTROL MODULE PINS.

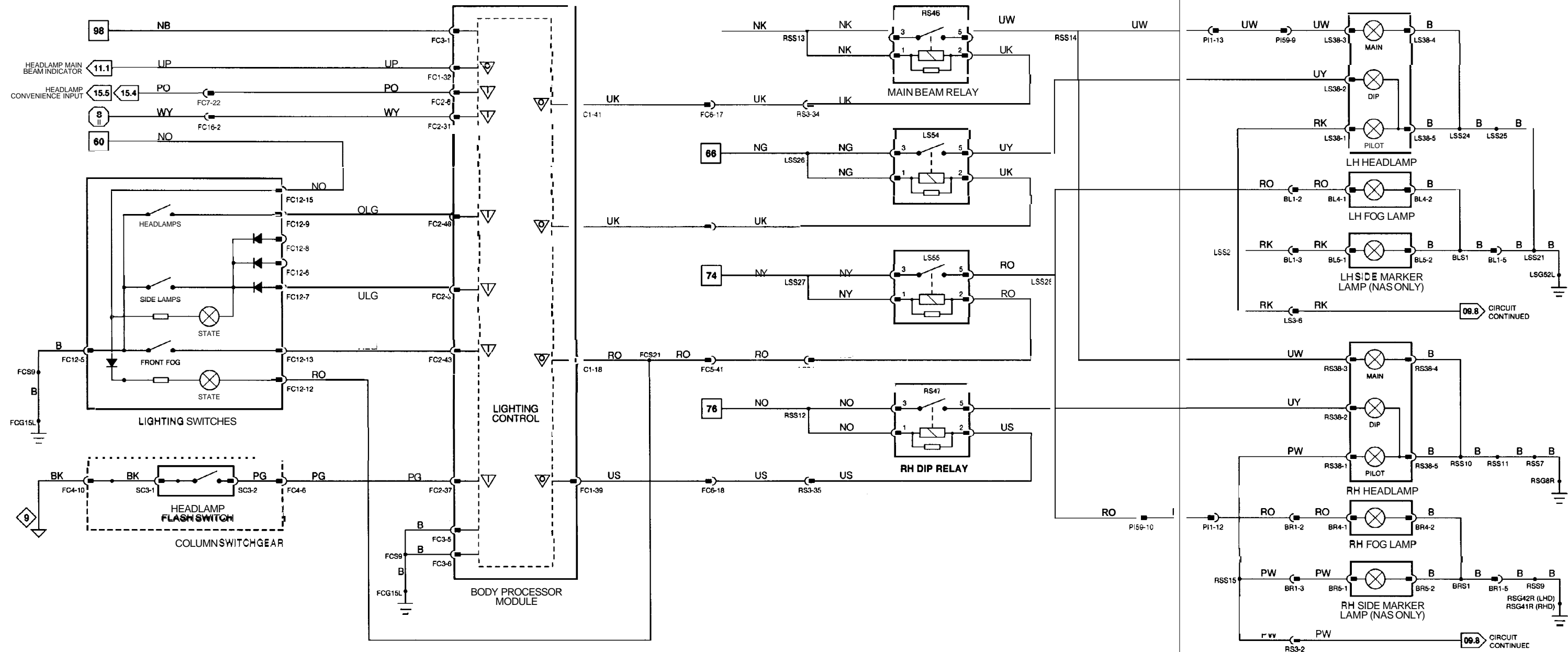

NOTE CANADA DAYTIME RUNNING LAMPS - BPM CONTROLLED (PECUS)

CONTROL MODULE PIN OUT INFORMATION

BODY PROCESSOR MODULE

Pin	Description	Active	Inactive
O FC1-14	LH PILOT BEAM, SIDE LAMPS AND TAIL LAMPS ON	GROUND	B+
O FC1-47	REAR FOG LAMPS AND STATE LAMP ON	GROUND	B+
I FC2-3	SIDE LAMPS ON	GROUND	B+
I FC2-31	IGNITION SWITCHED GROUND	GROUND	B+
I FC2-45	REAR FOG GUARD LAMP REQUEST	GROUND	B+

Fig. 09.8

COMPONENTS

Component	Connector	Type	Color	Location	Access
BODY PROCESSOR MODULE	FC1	48-WAY PCB SIGNAL	YELLOW	PASSENGER'S UNDERSCUTTLE	
	FC2	48-WAY PCB SIGNAL	BLACK		
	FC3	16-WAY PCB SIGNAL	BLACK		
LAMP CONTROL MODULE	BT20	18-WAY MULTILOCK	070 / WHITE	TRUNK ELECTRICAL CARRIER	
	BT21	120-WAY MULTILOCK	040 / BLACK		
LIGHTING SWITCHES	FC12	16-WAY MULTILOCK	040 / BLUE	FASCIA SWITCH PACK	
NUMBER PLATE LAMP - LH	BT27	12-WAY POSILOCK	BLACK	TRUNK LID / TRUNK LID TRIM	
NUMBER PLATE LAMP - RH	BT11	2-WAY POSILOCK	BLACK	TRUNK LID / TRUNK LID TRIM	
SIDE MARKER LAMP - LH	SR1-L	2-WAY JUNIOR TIMER	BLACK	LH FRONT LAMP UNIT	
SIDE MARKER LAMP - RH	SR1-R	2-WAY JUNIOR TIMER	BLACK	RH FRONT LAMP UNIT	
TAIL LAMP UNIT - LH	TL4	7-WAY JUNIOR TIMER	BLACK	LH REAR / TRUNK TRIM	
TAIL LAMP UNIT - RH	TL3	7-WAY JUNIOR TIMER	BLACK	RH REAR / TRUNK TRIM	

HARNESS-TO-HARNESS CONNECTORS

Connector	Type	Color	Location	Access
BT4	THROUGH-PANEL (48 MICRO / 6)	BLACK	PARCEL SHELF / FUEL TANK TRIM	
BTM	10-WAY MULTILOCK	0701 WHITE	TRUNK FLOOR TRIM / BATTERY COVER	
CC3	20-WAY MULTILOCK	040 / BLACK	CENTER CONSOLE / CENTER CONSOLE GLOVE BOX	
FC5	THROUGH-PANEL (48 MICRO / 6)	BLACK	LH FASCIA END PANEL / OUTER AIR VENT	
FC6	THROUGH-PANEL (48 MICRO / 6)	BLACK	RH FASCIA END PANEL / OUTER AIR VENT	
FC16	20-WAY MULTILOCK	040 / BLACK	PASSENGERS UNDERSCUTTLE	
LS3	THROUGH-PANEL (48 MICRO / 6)	BLACK	LH 'A' POST / 'A' POST PANEL	
RS3	THROUGH-PANEL (48 MICRO / 6)	BROWN	RH 'A' POST / 'A' POST	
TL5	2-WAY MULTILOCK	040 / GREEN	TRUNK LID / TRUNK LID TRIM	
TL6	2-WAY MULTILOCK	040 / GREEN	TRUNK LID / TRUNK LID TRIM	

GROUNDS

Ground	Location / Type
BTG48L	REAR TRUNK GROUND STUD
BTG49L	REAR TRUNK GROUND STUD
FCG15L	LH CONSOLE GROUND STUD

CONTROL MODULE PIN OUT INFORMATION (FOLD OUT PAGE)



The following symbols are used to represent values for Control Module Pin Out data:

I Input	B+ Battery voltage
O output	V Voltage (DC)
SG Signal Ground	Hz Frequency
D Serial and encoded communications	KHz Frequency x 1000
	MS Milliseconds
	MV Millivolts

CAUTION: The information on this data page is furnished to aid the user in understanding circuit operation. THIS INFORMATION SHOULD BE USED FOR REFERENCE ONLY.

NOTE: The values listed are approximately those that can be expected at the control module connector pins with all circuit connections made and all components connected and fitted. "Active" means a load is applied or a switch is ON; "Inactive" means a load is not applied or a switch is OFF.

REFER TO THE FRONT OF THE BOOK FOR ILLUSTRATIONS DETAILING THE LOCATION AND IDENTIFICATION OF COMPONENTS, RELAYS, CONNECTORS, HARNESES, GROUNDS, VEHICLE CONTROL MODULES AND CONTROL MODULE PINS.

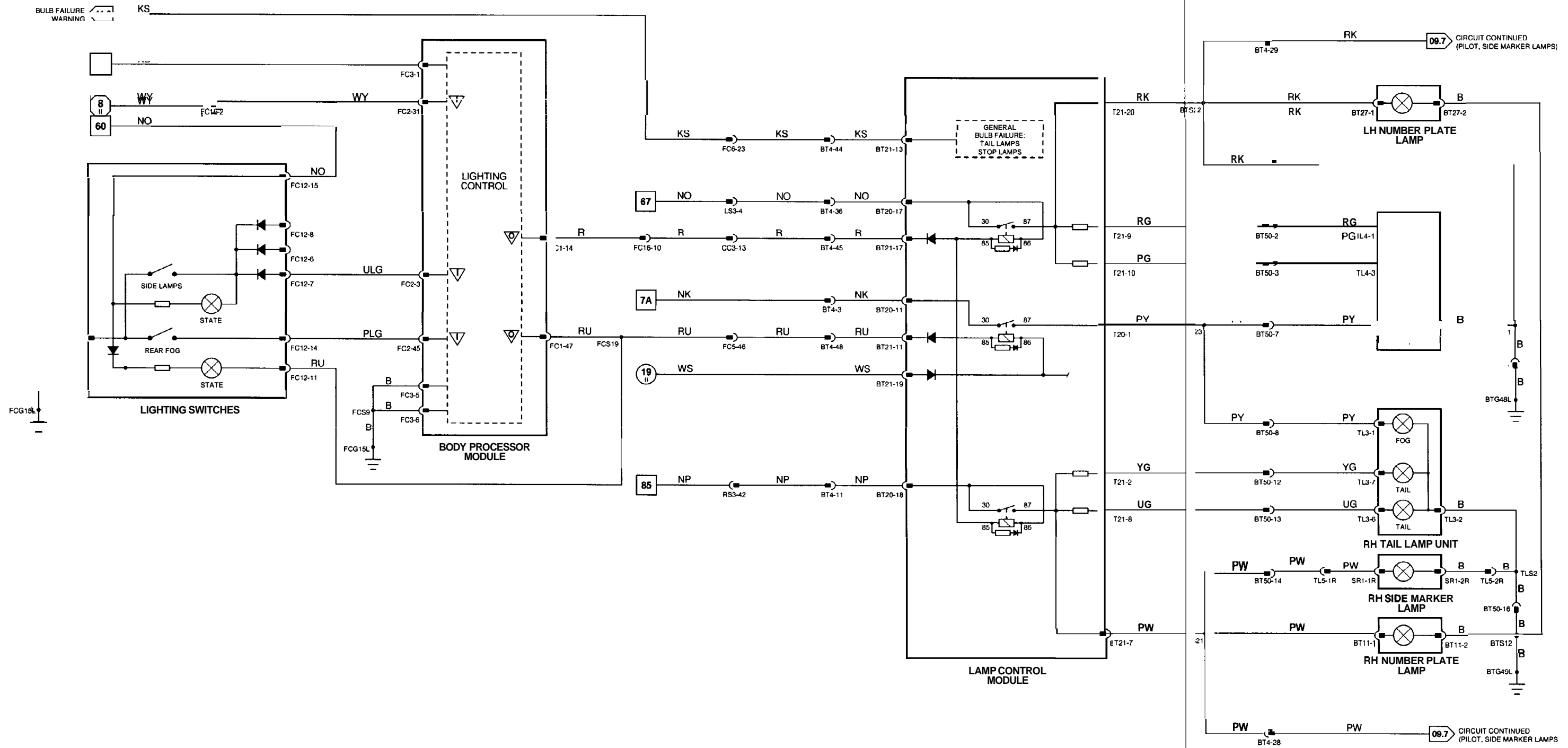

**Fig. 09.9**

**COMPONENTS**

Component	Connector / Type / Color	Location / Access
BRAKE SWITCH	CA72 / 4-WAY MULTILOCK 070 / WHITE	DRIVER'S UNDERSCUTTLE
DIODE (BT51) - HIGH MOUNTED STOP LAMP	BT51 / DIODE / BLACK	TRUNK HARNESS, ADJACENT TO BATTERY / RH FLOOR PANEL
HIGH MOUNTED STOP LAMP	CA35 / 3-WAY MT EDGE / SLATE	BACKLIGHT
LAMP CONTROL MODULE	BT20 / 18-WAY MULTILOCK 070 / WHITE	TRUNK ELECTRICAL CARRIER
	BT21 / 120-WAY MULTILOCK MOI / BLACK	
LINEAR GEAR POSITION SWITCHES	CC21 / 20-WAY MULTILOCK 040 / BLACK	'J' GATE / CENTER CONSOLE
REVERSE SWITCH (AJ16 MANUAL)	CC45 / 2-WAY SUMITOMO / WHITE	TRANSMISSION TUNNEL / CENTER CONSOLE
ROTARY SWITCH	GB1 (FLY LEAD) / 8-WAY MULTILOCK 070 / WHITE	'J' GATE / CENTER CONSOLE
	GB2 (FLY LEAD) / 112-WAY MULTILOCK 040 / BLACK	
TAIL LAMP UNIT - LH	TL4 / 7-WAY JUNIOR TIMER / BLACK	LH REAR / TRUNK TRIM
TAIL LAMP UNIT - RH	TL3 / 7-WAY JUNIOR TIMER / BLACK	RH REAR / TRUNK TRIM

**RELAYS**

Relay	Color / Stripe	Connector / Color	Location / Access
HIGH MOUNTED STOP LAMP RELAY	BLACK / VIOLET	BT13 / RED	TRUNK ELECTRICAL CARRIER

**HARNESS-TO-HARNESS CONNECTORS**

Connector	Type / Color	Location / Access
BT4	THROUGH-PANEL (48 MICRO / 6) / BLACK	PARCELSHELF / FUEL TANK TRIM
BT50	18-WAY MULTILOCK 070 / WHITE	TRUNK FLOOR TRIM / BATTERY COVER
CC3	20-WAY MULTILOCK 040 / BLACK	CENTER CONSOLE / CENTER CONSOLE GLOVE BOX
FC6	THROUGH-PANEL (48 MICRO / 6) / BLACK	RH FASCIA END PANEL / OUTER AIR VENT

**GROUNDS**

Ground	Location / Type
BTG18L	REAR TRUNK GROUND STUD
BTG49L	REAR TRUNK GROUND STUD
CAG30R	LH 'A' POST GROUND SCREW
CAG33R	RH HEELBOARD GROUND SCREW
CAG92R	RH HEELBOARD GROUND SCREW
CCG51L	CENTER CONSOLE GROUND STUD
CCG51R	CENTER CONSOLE GROUND STUD
CCG8L	CENTER CONSOLE GROUND STUD

REFER TO THE FRONT OF THE BOOK FOR ILLUSTRATIONS DETAILING THE LOCATION AND IDENTIFICATION OF COMPONENTS, RELAYS, CONNECTORS, HARNESSES, GROUNDS, VEHICLE CONTROL MODULES AND CONTROL MODULE PINS.



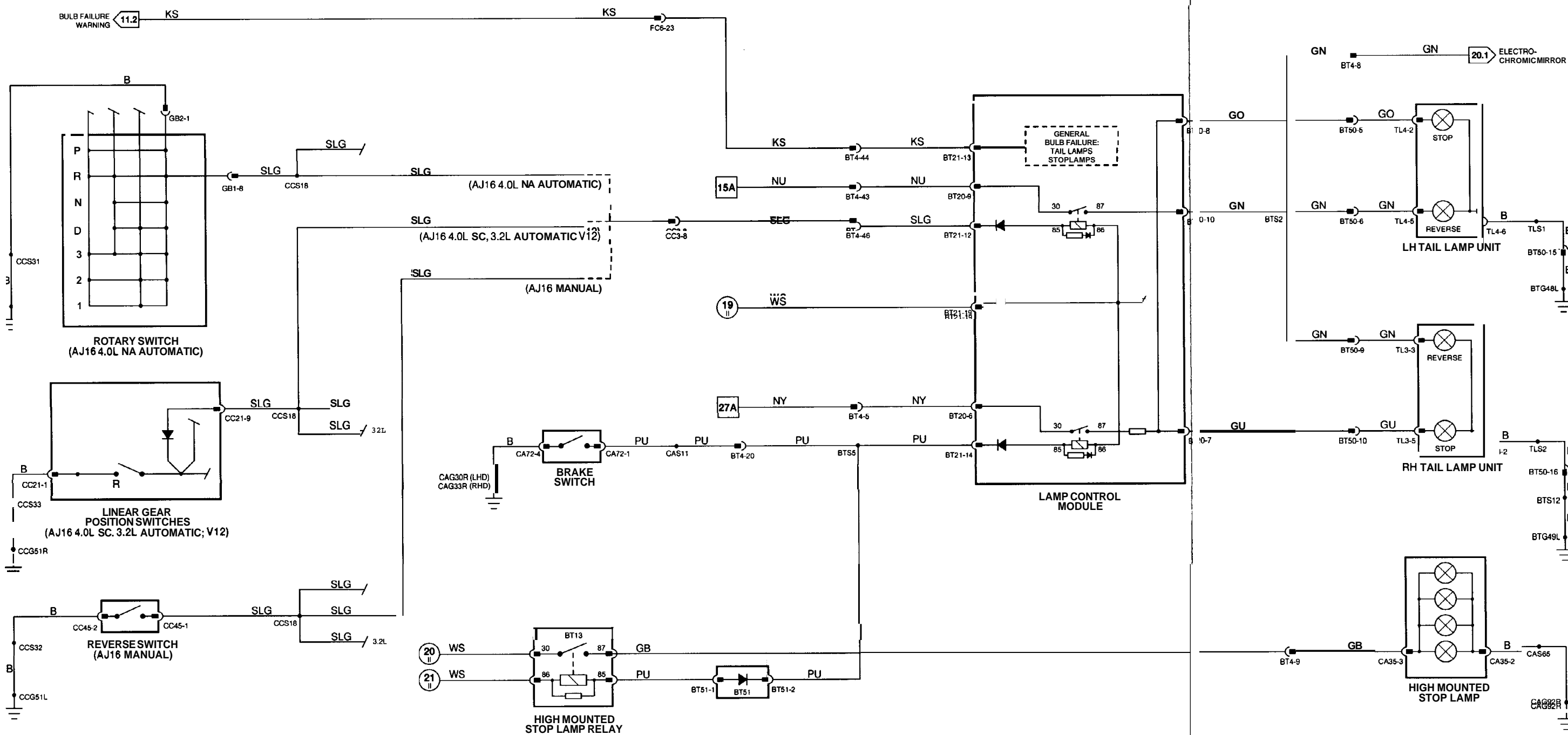

CONTROL MODULE PIN OUT INFORMATION

BODY PROCESSOR MODULE

Pin	Description	Active	Inactive
O FC1-17	LHDI INDICATOR	GROUND PULSE	B+
O FC1-19	RH DI INDICATOR	GROUND PULSE	B+
O FC1-38	HAZARD WARNING STATE LAMP	GROUND PULSE	B+
O FC1-46	DI BULB FAIL WARNING LAMP	GROUND	B+
I FC2-10	LHDI BULB FAILURE	GRDUND	B+
I FC2-18	RH DI REOUEST	GRDUND	B+
I FC2-27	HAZARD LAMPS REQUEST	GRDUND	B+
I FC2-31	IGNITION SWITCHED GROUND	GRDUND	B+
I FC2-34	RH DI FAILURE	GRDUND	B+
I FC2-42	RH GROUND DISCONNECT LOOP	GRDUND	B+
I FC2-44	LH GROUND DISCONNECT LOOP	GRDUND	B+
I FC2-46	LHDI REOUEST	GRDUND	B+

Fig. 09.10

COMPONENTS

Component	Connector / Type / Color	Location / Access
BODY PROCESSOR MODULE	FC1 / 48-WAY PCB SIGNAL / YELLOW FC2 / 48-WAY PCB SIGNAL / BLACK FC3 / 6-WAY PCB SIGNAL / BLACK	PASSENGERS UNDERSCUTTLE
CENTER CONSOLE SWITCH PACK AND CLOCK	CC1 116-WAY MULTILOCK MD / BLACK	CENTER CONSOLE
DIODE (FC59) - RH DI INDICATOR	FC59 DIODE / BLACK	FASCIA HARNESS / INSTRUMENT PACK
DIODE (FC60) - LHDI INDICATOR	FC60 / DIODE / BLACK	FASCIA HARNESS / INSTRUMENT PACK
DIRECTION INDICATOR SWITCHES (COLUMN SWITCHGEAR)	SC3 / 6-WAY MULTILOCK 070 / WHITE	STEERING COLUMN COVER
DIRECTION INMCATORS - LH FRONT	BL2 / 3-WAY JUNIOR TIMER / BLACK	LH FRONT / SPOILER
DIRECTION INDICATORS - RH FRONT	BR2 13-WAY JUNIOR TIMER / BLACK	RH FRONT / SPOILER
LAMP CONTROL MODULE	BT20 / 18-WAY MULTILOCK 070 / WHITE BT21 / 20-WAY MULTILOCK 0401 BLACK	TRUNK ELECTRICAL CARRIER
REPEATER - LH FRONT	LS17 12-WAY JUNIOR TIMER / BLACK	LH FRONT FENDER
REPEATER - RH FRONT	RS12 / 2-WAY JUNIOR TIMER / BLACK	RH FRONT FENDER
TAIL LAMP UNIT - LH	TL4 17-WAY JUNIOR TIMER / BLACK	LH REAR / TRUNK TRIM
TAIL LAMP UNIT - RH	TL3 / 1-WAY JUNIOR TIMER / BLACK	RH REAR / TRUNK TRIM

HARNESS-TO-HARNESS CONNECTORS

Connector	Type / Color	Location / Access
BL1	13-WAY ECONOSEAL III LC / BLACK	LH FRONT WHEEL ARCH LINER / SPOILER AND SPOILER TRAY
BR1	13-WAY ECONOSEAL III LC / BLACK	RH FRONT WHEEL ARCH LINER / SPOILER AND SPOILER TRAY
BT4	THROUGH-PANEL 148 MICRO / 6 / BLACK	PARCEL SHELF / FUEL TANK TRIM
BT50	10-WAY MULTILOCK 070 / WHITE	TRUNK FLOOR TRIM / BATTERY COVER
FC16	20-WAY MULTILOCK 040 / BLACK	PASSENGERS UNDERSCUTTLE
FC4	20-WAY MULTILOCK MD / BLUE	DRIVER'S UNDERSCUTTLE
FC5	THROUGH-PANEL (48 MICRO / 6) / BLACK	LH FASCIA END PANEL / OUTER AIR VENT
FC6	THROUGH-PANEL (48 MICRO / 6) / BLACK	RH FASCIA END PANEL / OUTER AIR VENT
FC7	THROUGH-PANEL (48 MICRO / 6) / BLACK	PASSENGER'S UNDERSCUTTLE
FC16	20-WAY MULTILOCK 040 / BLACK	PASSENGERS UNDERSCUTTLE
LS3	THROUGH-PANEL (48 MICRO / 6) / BLACK	LH 'A' POST / 'A' POST PANEL
RS3	THROUGH-PANEL (48 MICRO / 6) / BROWN	RH 'A' POST / 'A' POST PANEL

GROUNDS

Ground	Location / Type
BTG48L	REAR TRUNK GROUND STUD
BTG48R	REAR TRUNK GROUND STUD
BTG49L	REAR TRUNK GROUND STUD
CCG51L	CENTER CONSOLE GROUND STUD
FCG15L	LH CONSOLE GROUND STUD
LSG19R	LH BULKHEAD GROUND STUD
LSG52L	LEFT FORWARD GROUND STUD
RS41R	RIGHT FORWARD GROUND STUD
RS42R	RH BULKHEAD GROUND STUD

CONTROL MODULE PIN OUT INFORMATION (FOLD OUT PAGE)



The following symbols are used to represent values for Control Module Pin Out data:

I	Input	B+	Battery voltage
O	output	V	Voltage (DC)
SG	Signal Ground	Hz	Frequency
D	Serial and encoded communications	KHz	Frequency x 1000
		MS	Milliseconds
		MV	Millivolts

CAUTION: The information on this data page is furnished to aid the user in understanding circuit operation. THIS INFORMATION SHOULD BE USED FOR REFERENCE ONLY.

NOTE: The values listed are approximately those that can be expected at the control module connector pins with all circuit connections made and all components connected and fitted. "Active" means a load is applied or a switch is ON; "Inactive" means a load is not applied or a switch is OFF.

REFER TO THE FRONT OF THE BOOK FOR ILLUSTRATIONS DETAILING THE LOCATION AND IDENTIFICATION OF COMPONENTS, RELAYS, CONNECTORS, HARNESSES, GROUNDS, VEHICLE CONTROL MODULES AND CONTROL MODULE PINS.

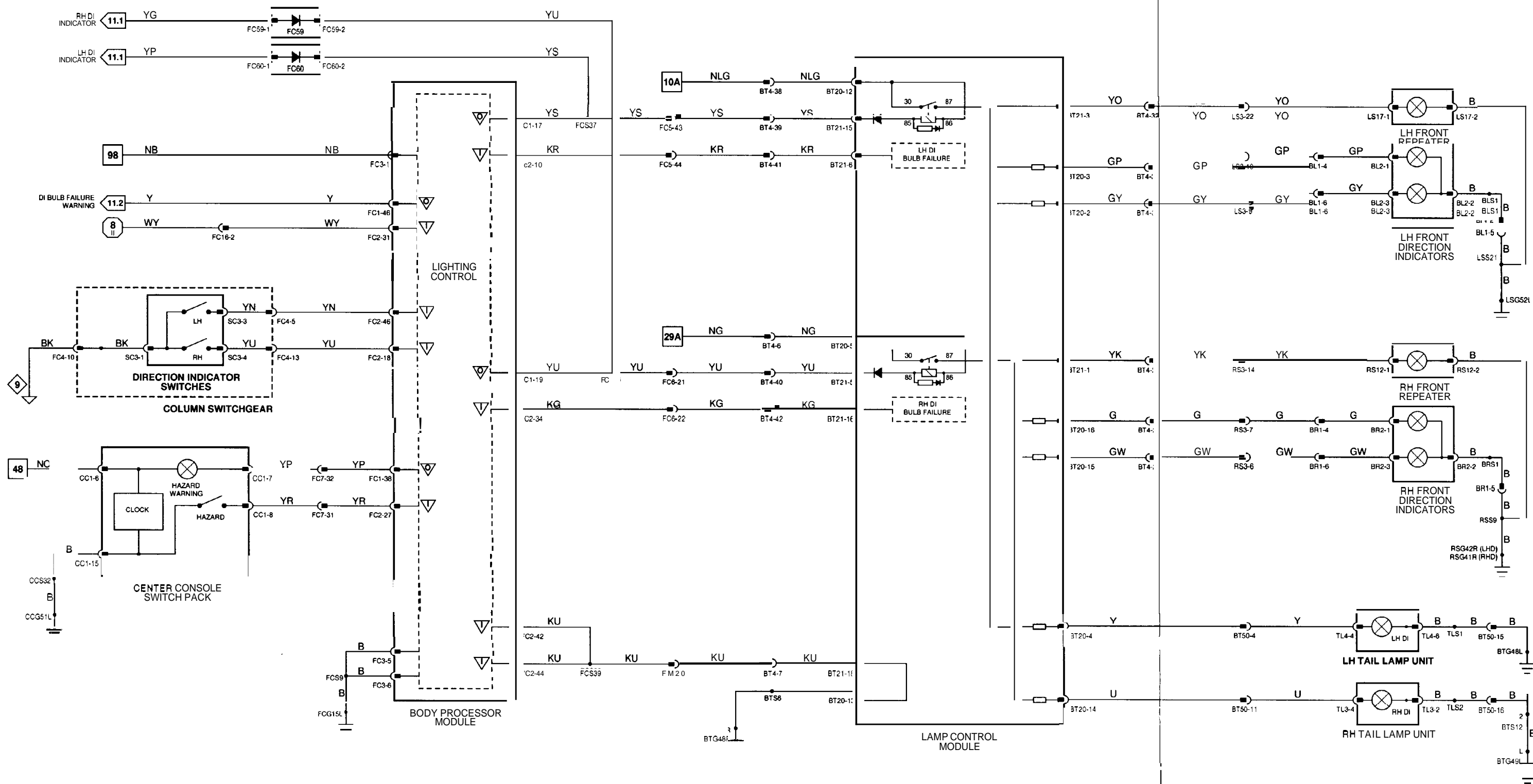

1-6

Fig. 01.1

7-65

Fig. 01.2

66-109

Fig. 01.3

I II

Fig. 01.4

III

Fig. 02.1

◇

Fig. 02.2

▽ Input

▽ Output

▽ Serial and Encoded Communications

▽ Signal Ground (SG)

VARIANT: All Vehicles  
VIN RANGE: 739427 →  
DATE OF ISSUE: APRIL 1995

CONTROL MODULE PIN OUT INFORMATION

BODY PROCESSOR MODULE

Pin	Description	Active	Inactive
O FC1-12	RH TRUNK LAMP	GROUND	B+
O FC1-15	LH TRUNK LAMP	GROUND	B+
O FC1-24	INTERIOR AND COURTESY LAMPS	GROUND	B+
O FC1-30	PUDDLE LAMP RELAY	GROUND	B+
I FC2-2	INTERIOR LAMPS ON	GROUND	B+
I FC2-29	CONSOLE INTERIOR LAMP SWITCH	GROUND	B+
I FC2-30	PASSENGER DOOR AJAR	GROUND	B+
I FC2-32	TRUNK AJAR	GROUND	B+
I FC2-33	DRIVER DOOR AJAR	GROUND	B+
I FC2-41	INTERIOR LAMP EXTINGUISH DURING CRANK	GROUND	B+
I FC2-48	KEY IN IGNITION SWITCH	GROUND	B+

Fig. 10.1

COMPONENTS

Component	Connector / Type Color	Location Access
BODY PROCESSOR MODULE	FC1 / 48-WAY PCB SIGNAL 1 BLACK	PASSENGERS UNDERSCUTTLE
DOOR SWITCH PACK - DRIVER	FC2 / 48-WAY PCB SIGNAL 1 BLACK FC3 / 12-WAY PCB SIGNAL / BLACK	ARM REST / TOP ROLL
DOOR SWITCH PACK - LH REAR	DD1 / 12-WAY MULTILOCK 47 / WHITE DD2 / 12-WAY MULTILOCK 47 / WHITE	DOOR CASING
DOOR SWITCH PACK - PASSENGER	RD1 L / 12-WAY MULTILOCK 070 / WHITE	ARM REST / TOP ROLL
DOOR SWITCH PACK - RH REAR	PD1 / 26-WAY MULTILOCK 47 / SLATE	DOOR CASING
DOOR SWITCH - DRIVER	RD1 R / 12-WAY MULTILOCK 070 / WHITE	DOOR CASING
DOOR SWITCH - LH REAR	DD3 / 13-WAY ECONOSEAL III LC / BLACK	DOOR CASING
DOOR SWITCH - PASSENGER	RD3 L / 16-WAY ECONOSEAL III LC / BLACK	DOOR CASING
DOOR SWITCH - RH REAR	PD3 / 13-WAY ECONOSEAL III LC / BLACK	DOOR CASING
E-WST LAMP - LH	RD3 R / 6-WAY ECONOSEAL III LC / BLACK	E' POST LAMP
E-POST LAMP - RH	CA89 / 14-WAY MULTILOCK 040 / BLACK	E' POST LAMP
GLOVE BOX LAMP	CA90 / 4-WAY MULTILOCK MO / BLACK	GLOVE BOX GLOVE BOX
IGNITION SWITCH	G11 / LUCAR / WHITE G12 / LUCAR / WHITE	STEERING COLUMN COVER DOOR CASING
INTERIOR / MAP LAMPS CONSOLE	FC54 (FLY LEAD) / 8 WAY MULTILOCK 070 / WHITE	DOOR CASING
PUWLE LAMP - DRIVER DOOR	CA83 / 8-WAY MULTILOCK / BLACK	DOOR CASING
PUDDLE LAMP - LH REAR DOOR	DO14 / 2 WAY JUNIOR TIMER / BLACK	DOOR CASING
PUDDLE LAMP - PASSENGER DOOR	RD7L / LUCAR / WHITE RDBL / LUCAR / WHITE	DOOR CASING
PUDDLE LAMP - RH REAR DOOR	PD14 / 2-WAY JUNIOR TIMER / BLACK	LH SUNVISOR
SUNVISOR LAMP - LH	RD7R / LUCAR / WHITE	RH SUNVISOR
SUNVISOR LAMP - RH	RD8R / LUCAR / WHITE	TRUNK, LH SIDE, REAR
TRUNK LAMP - LH	CA89 / 2-WAY MULTILOCK 040 / BLACK	TRUNK, RH SIDE, REAR
TRUNK LAMP - RH	CA70 / 2-WAY MULTILOCK MO / BLACK	TRUNK LID / TRUNK LID TRIM
TRUNK SWITCH	BT46 / 12-WAY JUNIOR TIMER / BLACK BT47 / 2-WAY JUNIOR TIMER / BLACK BT15 / 2 WAY FORD DIAGNOSTIC / BLACK	

RELAYS

Relay	Color / Stripe	Connector / Color	Location Access
PUDDLE LAMP RELAY - DRIVER	BLUE	CA53 / YELLOW	LH HEELBOARD

HARNESSTO-HARNESCONNECTORS

Connector	Type Color	Location Access
BT4	THROUGH-PANEL (48 MICRO / 6) / BLACK	PARCEL SHELF / FUEL TANK TRIM
CAB	20-WAY MULTILOCK MO / GREEN	DRIVER'S UNDERSCUTTLE
CA9	20-WAY MULTILOCK MO / BLACK	DRIVERS 'A' POST / 'A' WST TRIM
CA10	8-WAY MULTILOCK 070 / WHITE	DRIVER'S UNDERSCUTTLE
CA11	20-WAY MULTILOCK 040 / BLACK	PASSENGER'S UNDERSCUTTLE / ECM
CA12	12-WAY MULTILOCK 070 / WHITE	PASSENGERS UNDERSCUTTLE / ECM
CA13	12-WAY MULTILOCK MO / BLACK	LH 'BC' POST / 'BC' POST PANEL
CA14	2-WAY MULTILOCK 070 / WHITE	LH 'BC' POST / 'BC' POST PANEL
CA15	12-WAY MULTILOCK 040 / BLACK	RH 'BC' POST / 'BC' POST PANEL
CA16	2-WAY MULTILOCK 070 / WHITE	RH 'BC' POST / 'BC' POST PANEL
CC3	20-WAY MULTILOCK MO / BLACK	CENTER CONSOLE / CENTER CONSOLE GLOVE BOX
CC4	14-WAY MULTILOCK 070 / WHITE	CENTER CONSOLE / CENTER CONSOLE GLOVE BOX
CC5	20-WAY MULTILOCK 040 / GREEN	CENTER CONSOLE / CENTER CONSOLE GLOVE BOX
CC18	20-WAY MULTILOCK MO / BLUE	CENTER CONSOLE / CENTER CONSOLE
CC53	2-WAY MULTILOCK MO / BLACK	PASSENGERS UNDERSCUTTLE
FC5	THROUGH-PANEL (48 MICRO / 6) / BLACK	LH FASCIA END PANEL / OUTER AIR VENT
FC6	THROUGH-PANEL (48 MICRO / 6) / BLACK	RH FASCIA END PANEL / OUTER AIR VENT
FC7	THROUGH-PANEL (48 MICRO / 6) / BLACK	PASSENGERS UNDERSCUTTLE
FC16	20-WAY MULTILOCK MO / BLACK	PASSENGERS UNDERSCUTTLE

GROUNDS

Ground	Location Type
CAG30L	LH 'A' POST GROUND SCREW
CAGMR	LH 'A' POST GROUND SCREW
CAG31R	PARCEL SHELF GROUND SCREW
CAG33L	RH HEELBOARD GROUND SCREW
CAG92L	RH HEELBOARD GROUND SCREW
CAG93R	LH HEELBOARD GROUND SCREW
CCG51R	CENTER CONSOLE GROUND STUD
FCG15L	LH CONSOLE GROUND STUD
FCG26R	LH CONSOLE GROUND STUD

The following symbols are used to represent values for Control Module Pin Out data:

- I Input
- O output
- SG Signal Ground
- D Serial and encoded communications
- B+ Battery voltage
- V Voltage (DC)
- Hz Frequency
- KHz Frequency x 1000
- MS Milliseconds
- MV Millivolts

CAUTION The information on this data page is furnished to aid the user in understanding circuit operation. THIS INFORMATION SHOULD BE USED FOR REFERENCE ONLY.

NOTE: The values listed are approximately those that can be expected at the control module connector pins with all circuit connections made and all components connected and fitted. "Active" means a load is applied or a switch is ON; "Inactive" means a load is not applied or a switch is OFF.

CONTROL MODULE PIN OUT INFORMATION (FOLD OUT PAGE)



REFER TO THE FRONT OF THE BOOK FOR ILLUSTRATIONS DETAILING THE LOCATION AND IDENTIFICATION OF COMPONENTS, RELAYS, CONNECTORS, HARNESSES, GROUNDS, VEHICLE CONTROL MODULES AND CONTROL MODULE PINS.

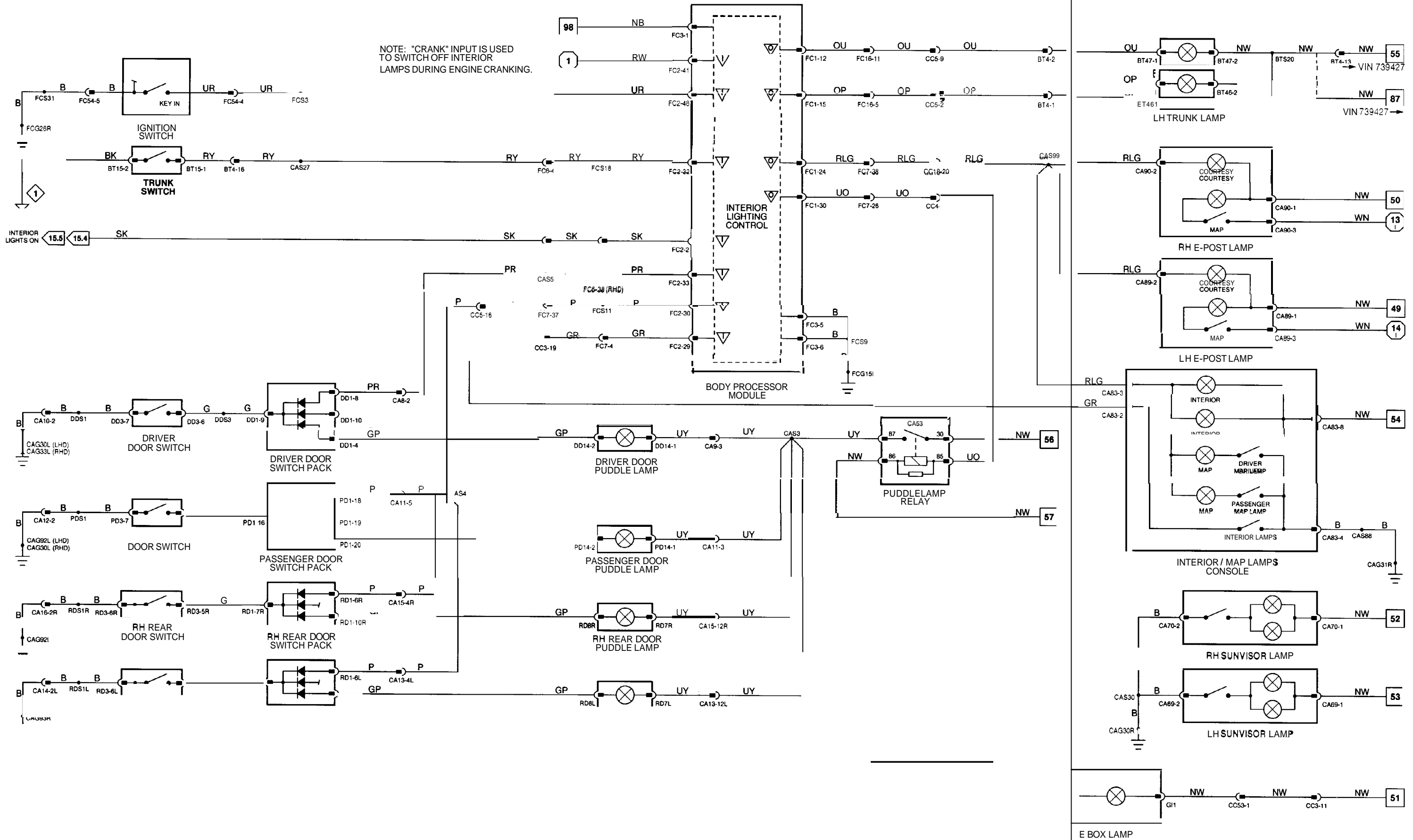

CONTROL MODULE PIN OUT INFORMATION

DIMMER

Pin	Description	Active	Inactive
o SC1-1	ILLUMINATION SUPPLY	B+	GROUND
I SC1-2	SIDE LAMPS ON	0.6 V	B+
o SC1-7	ILLUMINATION SUPPLY	B+	GROUND

**Fig. 10.2**

COMPONENTS

Component	Connector / Type / Color	Location / Access
AIR CONDITIONING CONTROL MODULE	CC28 / 26-WAY MULTILOCK 47 / SLATE CC29 / 16-WAY MULTILOCK 41 / SLATE CC30 / 12-WAY MULTILOCK 47 / SLATE CC31 / 22-WAY MULTILOCK 47 / SLATE	A/C UNIT, RH SIDE / RH UNDERSCUTTLE
AIR CONDITIONING CONTROL PANEL	CC2 (FLY LEAD) 112-WAY MULTILOCK 040 / BLUE	CENTER CONSOLE
CENTER CONSOLE SWITCH PACK	CC1 / 16-WAY MULTILOCK 040 / BLACK	CENTER CONSOLE
CIGAR LIGHTER - FRONT	CC9 / 2-WAY SERIES 250 / BLACK CC10 / LUCAR / BLACK	CENTER CONSOLE
CIGAR LIGHTER - REAR	CC16 / 2-WAY SERIES 250 / BLACK CC17 / LUCAR / BLACK	CENTER CONSOLE
DIMMER (COLUMN SWITCHGEAR)	SC1 / 8-WAY MULTILOCK 20 / WHITE	STEERING COLUMN / COVER
W O R SWITCH PACK - DRIVER	DD1 / 12-WAY MULTILOCK 47 / WHITE DD2 / 22-WAY MULTILOCK 47 / WHITE	ARM REST/TOP ROLL
DOOR SWITCH PACK - LH REAR	RD1-L / 12-WAY MULTILOCK 070 / WHITE	DOOR CASING
DOOR SWITCH PACK - PASSENGER	PD1 / 126-WAY MULTILOCK 47 / SLATE	ARM REST/TOP ROLL
DOOR SWITCH PACK - RH REAR	RD1-R / 12-WAY MULTILOCK 070 / WHITE	DOOR CASING
FASCIA SWITCH PACK	FC18 / 16-WAY MULTILOCK 040 / BLACK	STEERING COLUMN / DRIVER'S UNMRSCUTTLE
INSTRUMENT PACK	FC9 / 24-WAY IDC / BLACK FC10 / 48-WAY IDC / BLACK	INSTRUMENT PACK
INTERIOR MAP LAMPS CONSOLE	CA03 / 18-WAY MULTILOCK / BLACK	ROOF CONSOLE
LIGHTING SWITCHES	FC12 / 16-WAY MULTILOCK 040 / BLUE	FASCIA SWITCH PACK
RADIO	IC1 / 120-WAY MULTILOCK 070 / WHITE	CENTER CONSOLE

HARNESS-TO-HARNESSCONNECTORS

Connector	Type / Color	Location / Access
CA9	20-WAY MULTILOCK 040 / BLACK	DRIVER'S 'A' POST / 'A' POST TRIM
CA10	8-WAY MULTILOCK 070 / WHITE	DRIVER'S UNDERSCUTTLE
CA11	20-WAY MULTILOCK 040 / BLACK	PASSENGERS UNDERSCUTTLE / ECM
CA12	12-WAY MULTILOCK 070 / WHITE	PASSENGER'S UNDERSCUTTLE / ECM
CA13	12-WAY MULTILOCK 040 / BLACK	LH 'BC' POST / 'BC' POST PANEL
CA14	2-WAY MULTILOCK 070 / WHITE	LH 'BC' POST / 'BC' POST PANEL
CA15	12-WAY MULTILOCK 070 / BLACK	RH 'BC' POST / 'BC' POST PANEL
CA16	2-WAY MULTILOCK 070 / WHITE	RH 'BC' POST / 'BC' POST PANEL
CC18	20-WAY MULTILOCK 040 / BLUE	CENTER CONSOLE / CENTER CONSOLE
FC4	20-WAY MULTILOCK 040 / BLUE	DRIVER'S UNDERSCUTTLE
FC7	THROUGH-PANEL (48 MICRO) / 6 / BLACK	PASSENGERS UNDERSCUTTLE
IC7	8-WAY MULTILOCK 070 / WHITE	PASSENGER'S UNDERSCUTTLE

GROUNDS

Ground	Location / Type
CAG30L	LH 'A' POST GROUND SCREW
CAG31R	PARCEL SHELF GROUND SCREW
CAG33R	RH HEELBOARD GROUND SCREW
CAG92L	RH HEELBOARD GROUND SCREW
CAG92R	RH HEELBOARD GROUND SCREW
CCG49R	RH CONSOLE GROUND STUD
CCGML	CENTER CONSOLE GROUND
CCG50R	CENTER CONSOLE GROUND
CCG51L	CENTER CONSOLE GROUND STUD
FCG15L	LH CONSOLE GROUND STUD
FCG26R	LH CONSOLE GROUND STUD
ICG24	RADIO GROUND STUD

CONTROL MODULE PIN OUT INFORMATION (FOLDOUT PAGE)



The following symbols are used to represent values for Control Module Pin Out data:

I Input	B+ Battery voltage
O output	V Voltage (DC)
SG Signal Ground	Hz Frequency
D Serial and encoded communications	KHz Frequency x 1000
	MS Milliseconds
	MV Millivolts

CAUTION The information on this data page is furnished to aid the user in understanding circuit operation. THIS INFORMATION SHOULD BE USED FOR REFERENCE ONLY.

NOTE: The values listed are approximately those that can be expected at the control module connector pins with all circuit connections made and all components connected and fitted. "Active" means a load is applied or a switch is ON; "Inactive" means a load is not applied or a switch is OFF.

REFER TO THE FRONT OF THE BOOK FOR ILLUSTRATIONS DETAILING THE LOCATION AND IDENTIFICATION OF COMPONENTS, RELAYS, CONNECTORS, HARNESSES, GROUNDS, VEHICLE CONTROL MODULES AND CONTROL MODULE PINS.

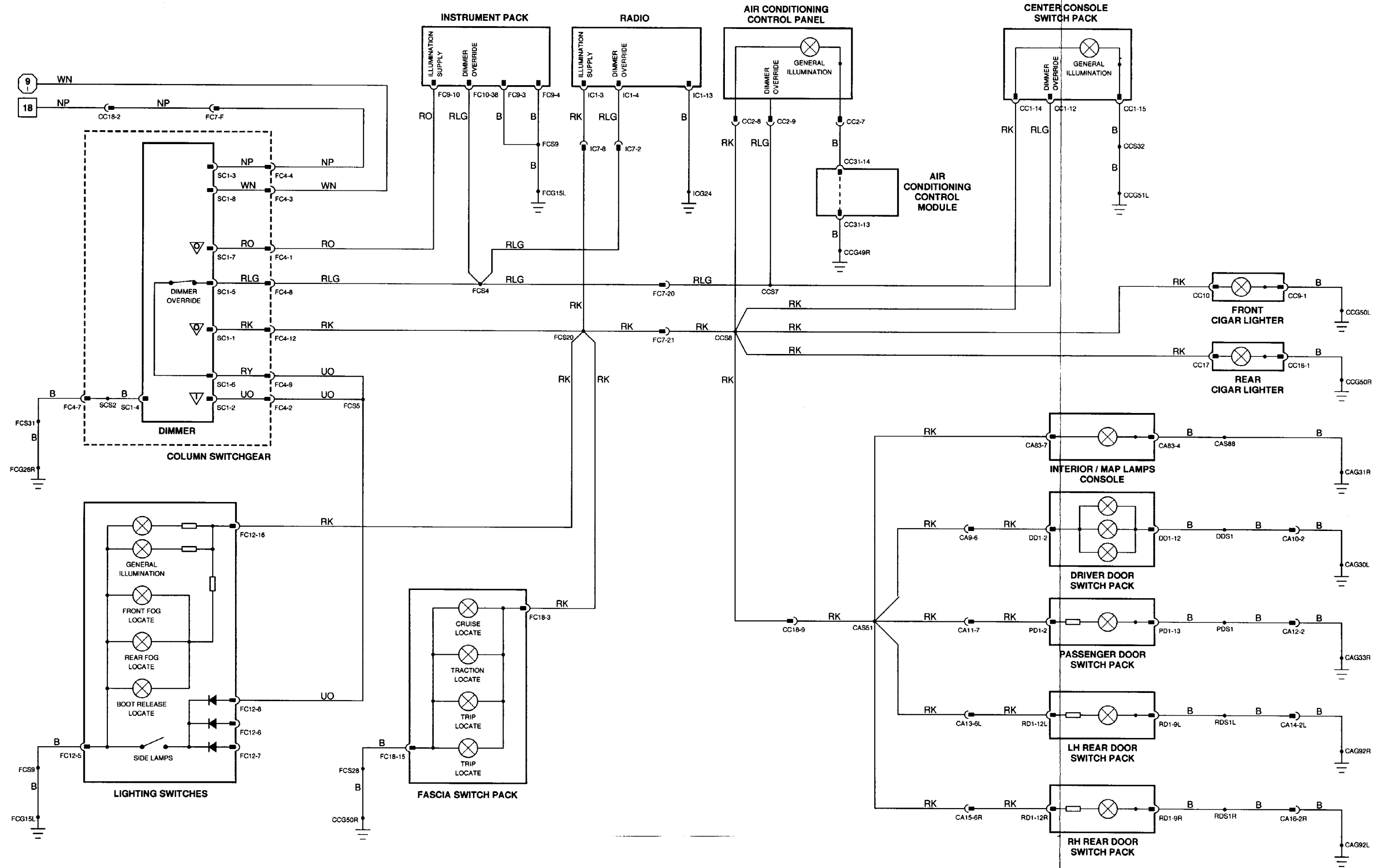

CONTROL MODULE PIN OUT INFORMATION CONTROL MODULE PIN OUT INFORMATION

INSTRUMENT PACK

Pin	Description	Active	Inactive
D FC9-13	SERIAL COMMUNICATION INPUT		
D FC9-14	SERIAL COMMUNICATION OUTPUT		
I FCP-15	VEHICLE SPEED INPUT		
I FC9-19	COOLANT TEMPERATURE INDICATOR LAMP	B+ @ 10 MPH = 200 Hz, 20 MPH = 400 Hz	B+
I FCP-20	FUEL LEVEL	GROUND	B+ = EMPTY
I FC9-21	ENGINE OIL PRESSURE	GROUND = FULL	B+ = MINIMUM PRESSURE
O FCS-22	ENGINE COOLANT TEMPERATURE	GROUND = MAXIMUM PRESSURE	
I FC9-24	TACHOMETER	2.5 V @ 90° C. INCREASING WITH TEMPERATURE INCREASE	
		GROUND PULSE @ 1000 RPM = 15 Hz	
O FC10-2	VEHICLE SPEED SIGNAL	B+ @ 10 MPH (16 KPH) = 20 Hz, 20 MPH (32 KPH) = 40 Hz	
O FC10-3	VEHICLE SPEED SIGNAL	GROUND @ 10 MPH (16 KPH) = 20 Hz, 20 MPH (32 KPH) = 40 Hz	
I FC10-4	TRIP STALK CYCLE	GROUND	B+
I FC10-9	GENERATOR INDICATOR VOLTAGE	< 10.4 V OR > 15.6 V	10.5-15.5 V
I FC10-12	TRIP RESET	GROUND	B+
I FC10-14	TRANSMISSION SPORT MODE	GROUND = SPORT	B+
I FC10-17	PARK BRAKE ON	GROUND	B+
I FC10-24	MAIN BEAM	GROUND	B+
I FC10-35	TRACTION CONTROL STATUS	B+	B+
		FAILURE = GROUND	FAILURE = GROUND
		TRACTION OFF = 4 Hz GROUND PULSE	
I FC10-36	TRIP CLEAR	GROUND	B+
I FC10-40	LH DI ON	GROUND PULSE	B+
I FC10-41	RH DI ON	GROUND PULSE	B+
I FC10-42	MPH KPH	GROUND	B+

Fig. 11.1

COMPONENTS

Component	Connector / Type Color	Location / Access
COOLANT TEMPERATURE SENSOR	P1140 / LUCAR BLACK	ENGINE THERMOSTAT HOUSING
FASCIA SWITCH PACK	FC18 16-WAY MULTILOCK 040 / BLACK	STEERING COLUMN DRIVERS UNDERSCUTTLE
FUEL LEVEL SENSOR	BT32; BT33 LUCAR / WHITE	FUEL TANK FUEL TANK TRIM
HAND BRAKE SWITCH	CC52 12-WAY MULTILOCK 040 BLACK	CENTER CONSOLE, LH SIDE
INSTRUMENT PACK	FC9 24-WAY IDC / BLACK FC10 / 48-WAY IDC BLACK	INSTRUMENT PACK
OIL PRESSURE SENSOR	P1139 / LUCAR BLACK	ENGINE BLOCK, LH SIDE (AJ18); ENGINE VEE, REAR (V12)
TRIP CYCLE (COLUMN SWITCHGEAR)	SC3 / 6-WAY MULTILOCK 070 / WHITE	STEERING COLUMN / COVER

HARNESSTO-HARNESSTO CONNECTORS

Connector	Type / Color	Location / Access
BT4	THROUGH-PANEL (48 MICRO / 6) / BLACK	PARCELSHELF / FUEL TANK TRIM
CC5	20-WAY MULTILOCK 040 GREEN	CENTER CONSOLE / CENTER CONSOLE GLOVE BOX
FC4	20-WAY MULTILOCK 040 / BLUE	DRIVER'S UNDERSCUTTLE
FC5	THROUGH-PANEL (48 MICRO / 6) BLACK	LH FASCIA END PANEL / OUTER AIR VENT
FC6	THROUGH-PANEL (48 MICRO / 6) BLACK	RH FASCIA END PANEL / OUTER AIR VENT
FC7	THROUGH-PANEL (48 MICRO / 6) / BLACK	PASSENGER'S UNDERSCUTTLE
FC16	20-WAY MULTILOCK 040 BLACK	PASSENGER'S UNDERSCUTTLE
IC7	8-WAY MULTILOCK 070 / WHITE	PASSENGER'S UNDERSCUTTLE
P11	13-WAY ECONOSEAL III LC / WHITE	RH AIR CLEANER
P161	13-WAY ECONOSEAL III LC BLACK	RH AIR CLEANER
P163	20-WAY MULTILOCK 040 / BLACK	RH 'A' POST / 'A' POST TRIM
RS3	THROUGH-PANEL (48 MICRO / 6) BROWN	RH 'A' POST / 'A' POST PANEL

GROUNDS

Ground	Location Type
BTG48R	REAR TRUNK GROUND S N D
FCG15L	LH CONSOLE GROUND STUD
FCG26L	LH CONSOLE GROUND STUD

CONTROL MODULE PIN OUT INFORMATION (FOLD OUT PAGE)



The following symbols are used to represent values for Control Module Pin Out data:

I	Input	B+	Battery voltage
O	Output	V	Voltage (DC)
SG	Signal Ground	Hz	Frequency
D	Serial and encoded communications	KHz	Frequency x 1000
		MS	Milliseconds
		MV	Millivolts

CAUTION: The information on this data page is furnished to aid the user in understanding circuit operation. THIS INFORMATION SHOULD BE USED FOR REFERENCE ONLY.

NOTE: The values listed are approximately those that can be expected at the control module connector pins with all circuit connections made and all components connected and fitted. "Active" means a load is applied or a switch is ON; "Inactive" means a load is not applied or a switch is OFF.

REFER TO THE FRONT OF THE BOOK FOR ILLUSTRATIONS DETAILING THE LOCATION AND IDENTIFICATION OF COMPONENTS, RELAYS, CONNECTORS, HARNESSES, GROUND, VEHICLE CONTROL MODULES AND CONTROL MODULE PINS.



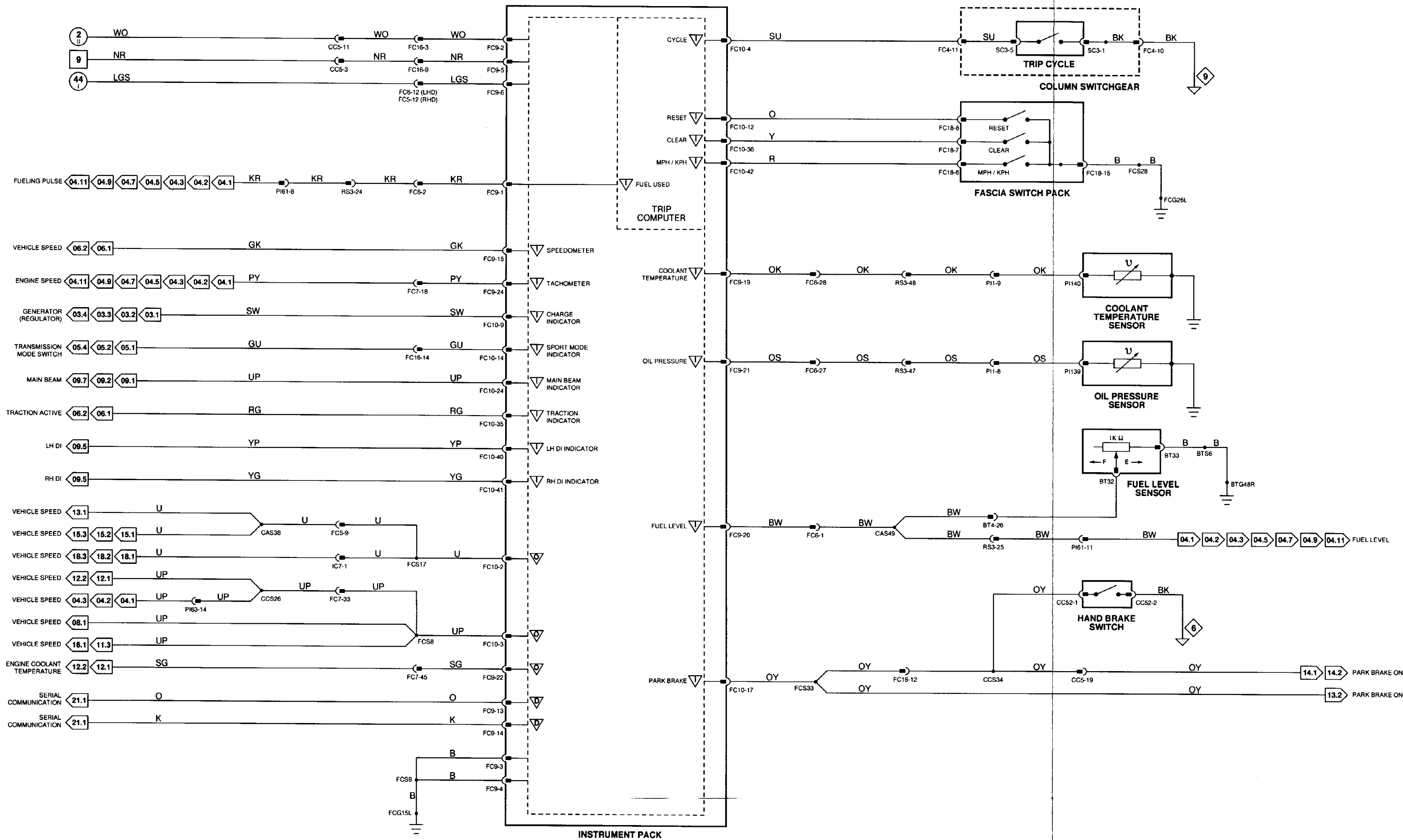

CONTROL MODULE PIN OUT INFORMATION

BODY PROCESSOR MODULE

Pin	Description	Active	Inactive
O FC1-26	SEAT BELT WARNING LAMP	GROUND	B+
I FCZ-24	SEAT BELT WARNING LAMP	GROUND	B+

DRIVER SEAT CONTROL MODULE (NAS)

Pin	Description	Active	Inactive
O CA105-20	SEAT BELT WARNING	GROUND	B+
I SM6-21D	SEAT BELT FASTENED	GROUND	B+

DRIVER SEAT CONTROL MODULE (ROW)

Pin	Description	Active	Inactive
O PL1-20D	SEAT BELT WARNING	GROUND	B+
I SM6-21D	SEAT BELT FASTENED	GROUND	B+

INSTRUMENT PACK

Pin	Description	Active	Inactive
I FC9-7	ANTI-LOCK FAILURE	< 5.1 V OR > 11.9 V	5.1 - 11.8 V
D FC9-13	SERIAL COMMUNICATION INPUT		
D FC9-14	SERIAL COMMUNICATION OUTPUT		

FC10-10	BRAKE FLUID LEVEL	GROUND	B+
I FC10-13	WASHER FLUID LEVEL	GROUND	B+
I FC10-15	SEAT BELT WARNING	GROUND	B+
I FC10-16	TRUNK AJAR	GROUND	7.9 V
I FC10-18	DI BULB FAILURE	GROUND	B+
I FC10-22	CHECK ENGINE MIL	GROUND	B+
I FC10-23	EXHAUST TEMPERATURE (JAPAN ONLY)	GROUND	B+
I FC10-37	COOLANT LEVEL	GROUND	B+
I FC10-43	GENERAL BULB FAIL	GROUND	B+
I FC10-44	TRANSMISSION MIL	GROUND	B+
FC10-45	AIR BAG FAILURE	GROUND	B+
I FC10-46	DRIVER WOR AJAR	GROUND	7.9 V
FC10-47	PASSENGER DOOR AJAR	GROUND	7.9 V

Fig. 11.2

COMPONENTS

Component	Connector	Type	Color	Location	Access
BODY PROCESSOR MODULE	FC1	48-WAY PCB SIGNAL	YELLOW	PASSENGERS UNDERSCUTTLE	
	FC2	148-WAY PCB SIGNAL	BLACK		
	FC3	16-WAY PCB SIGNAL	BLACK		
BRAKE FLUID LEVEL SWITCH (LHD)	LS28	2-WAY JUNIOR TIMER	BLACK	BRAKE FLUID RESERVOIR	
BRAKE FLUID LEVEL SWITCH (RHD)	RS36	2-WAY JUNIOR TIMER	BLACK	BRAKE FLUID RESERVOIR	
COOLANT LEVEL SWITCH	LS33	12-WAY JUNIOR TIMER	BROWN	COOLANT RESERVOIR	
WOR SWITCH PACK - LH REAR	RD1-L	12-WAY MULTILOCK	070 / WHITE	DOOR CASING	
DOOR SWITCH PACK - PASSENGER	PD1	26-WAY MULTILOCK	47 / SLATE	ARM REST / TOP ROLL	
DOOR SWITCH PACK - RH REAR	RD1-R	12-WAY MULTILOCK	070 / WHITE	DOOR CASING	
DOOR SWITCH - DRIVER	003	113-WAY ECONOSEAL III LC	BLACK	DOOR CASING	
DOOR SWITCH - LH REAR	RD3-L	6-WAY ECONOSEAL III LC	BLACK	DOOR CASING	
DOOR SWITCH - PASSENGER	PD3	113-WAY ECONOSEAL III LC	BLACK	DOOR CASING	
DOOR SWITCH - RH REAR	RD3-R	6-WAY ECONOSEAL III LC	BLACK	DOOR CASING	
INSTRUMENT PACK	FC9	124-WAY IDC	BLACK	INSTRUMENT PACK	
	FC10	48-WAY IDC	BLACK		
SEAT BELT SWITCH	SMB	2-WAY MULTILOCK	M O / BLACK	DRIVER'S SEAT / UNDER	
SEAT CONTROL MODULE - DRIVER (NAS VEHICLES)	CA105	22-WAY MULTILOCK	47 / BLUE	DRIVER'S SEAT	
	CA106	12-WAY MULTILOCK	47 / BLUE		
SEAT CONTROL MODULE - DRIVER (ROW, MEMORY SEAT VEHICLES)	SM1-D	12-WAY MULTILOCK	47 / WHITE	DRIVER'S SEAT	
	SM6-D	22-WAY MULTILOCK	47 / WHITE		
	PL1	22-WAY MULTILOCK	47 / BLUE		
	PL2	12-WAY MULTILOCK	41 / BLUE		
	SM1-D	12-WAY MULTILOCK	47 / WHITE		
	SM6-D	22-WAY MULTILOCK	47 / WHITE		
TRUNK SWITCH	BT15	2-WAY FORD DIAGNOSTIC	BLACK	TRUNK LID / TRUNK LID TRIM	
WASHER FLUID LEVEL SWITCH	RS18	2-WAY ECONOSEAL III LC	RED	WASHER FLUID RESERVOIR	

HARNESSTO-HARNESCONNECTORS

Connector	Type	Color	Location / Access
BT4	THROUGH-PANEL	48 MICRO / 6 / BLACK	PARCEL SHELF / FUEL TANK TRIM
CA9	20-WAY MULTILOCK	040 / BLACK	DRIVER'S 'A' POST / 'A' POST TRIM
CA10	8-WAY MULTILOCK	070 / WHITE	DRIVER'S UNDERSCUTTLE
CA11	20-WAY MULTILOCK	040 / BLACK	PASSENGER'S 'A' POST / 'A' POST TRIM
CA12	12-WAY MULTILOCK	070 / WHITE	PASSENGERS UNDERSCUTTLE / ECM
CA13	12-WAY MULTILOCK	040 / BLACK	LH 'BC' POST / 'BC' POST PANEL
CA14	2-WAY MULTILOCK	070 / WHITE	LH 'BC' POST / 'BC' POST PANEL
CA15	12-WAY MULTILOCK	040 / BLACK	RH 'BC' POST / 'BC' POST PANEL
CA16	2-WAY MULTILOCK	070 / WHITE	RH 'BC' POST / 'BC' POST PANEL
CA23	20-WAY MULTILOCK	040 / BLACK	DRIVER'S SEAT
CA25	3-WAY MULTILOCK	070 / YELLOW	RH 'A' POST, ECM / 'A' POST PANEL
CC5	20-WAY MULTILOCK	040 / GREEN	CENTER CONSOLE / CENTER CONSOLE GLOVE BOX
CC18	20-WAY MULTILOCK	040 / BLUE	CENTER CONSOLE / CENTER CONSOLE
FC5	THROUGH-PANEL	148 MICRO / 6 / BLACK	LH FASCIA END PANEL / OUTER AIR VENT
FC6	THROUGH-PANEL	148 MICRO / 6 / BLACK	RH FASCIA END PANEL / OUTER AIR VENT
FC7	THROUGH-PANEL	48 MICRO / 6 / BLACK	PASSENGERS UNDERSCUTTLE
FC16	20-WAY MULTILOCK	040 / BLACK	PASSENGERS UNDERSCUTTLE
LS3	THROUGH-PANEL	48 MICRO / 6 / BLACK	LH 'A' POST / 'A' POST PANEL
ML1-D	10-WAY MULTILOCK	070 / WHITE	DRIVER'S SEAT / UNDER
PI61	13-WAY ECONOSEAL III LC	BLACK	RH AIR CLEANER
PI63	20-WAY MULTILOCK	M O / BLACK	RH 'A' POST / 'A' POST TRIM
RS3	THROUGH-PANEL	48 MICRO / 6 / BROWN	RH 'A' POST / 'A' POST PANEL

GROUNDS

Ground	Location	Type
CAG30L	LH 'A' POST	GROUND SCREW
CAG33L	RH HEELBOARD	GROUND SCREW
CAG92L	RH HEELBOARD	GROUND SCREW
CAG93R	LH HEELBOARD	GROUND SCREW
CAG103L	LH SEAT	GROUND STUD
FCG15L	LH CONSOLE	GROUND STUD
LSG19R	LH BULKHEAD	GROUND STUD
MLG2L	LH SEAT	GROUND SCREW
PLGK	LH SEAT	GROUND SCREW
RS41L	RIGHT FORWARD	GROUND

CONTROL MODULE PIN OUT INFORMATION (FOLDOUT PAGE)



The following symbols are used to represent values for Control Module Pin Out data:

I	Input	B+	Battery voltage
O	Output	V	Voltage (DC)
SG	Signal Ground	Hz	Frequency
D	Serial and encoded communications	KHz	Frequency x 1000
		MS	Milliseconds
		MV	Millivolts

CAUTION The information on this data page is furnished to aid the user in understanding circuit operation. THIS INFORMATION SHOULD BE USED FOR REFERENCE ONLY.

NOTE: The values listed are approximately those that can be expected at the control module connector pins with all circuit connections made and all components connected and fitted. "Active" means a load is applied or a switch is ON; "Inactive" means a load is not applied or a switch is OFF.

REFER TO THE FRONT OF THE BOOK FOR ILLUSTRATIONS DETAILING THE LOCATION AND IDENTIFICATION OF COMPONENTS, RELAYS, CONNECTORS, HARNESS GROUNDS, VEHICLE CONTROL MODULE AND CONTROL MODULE PINS.

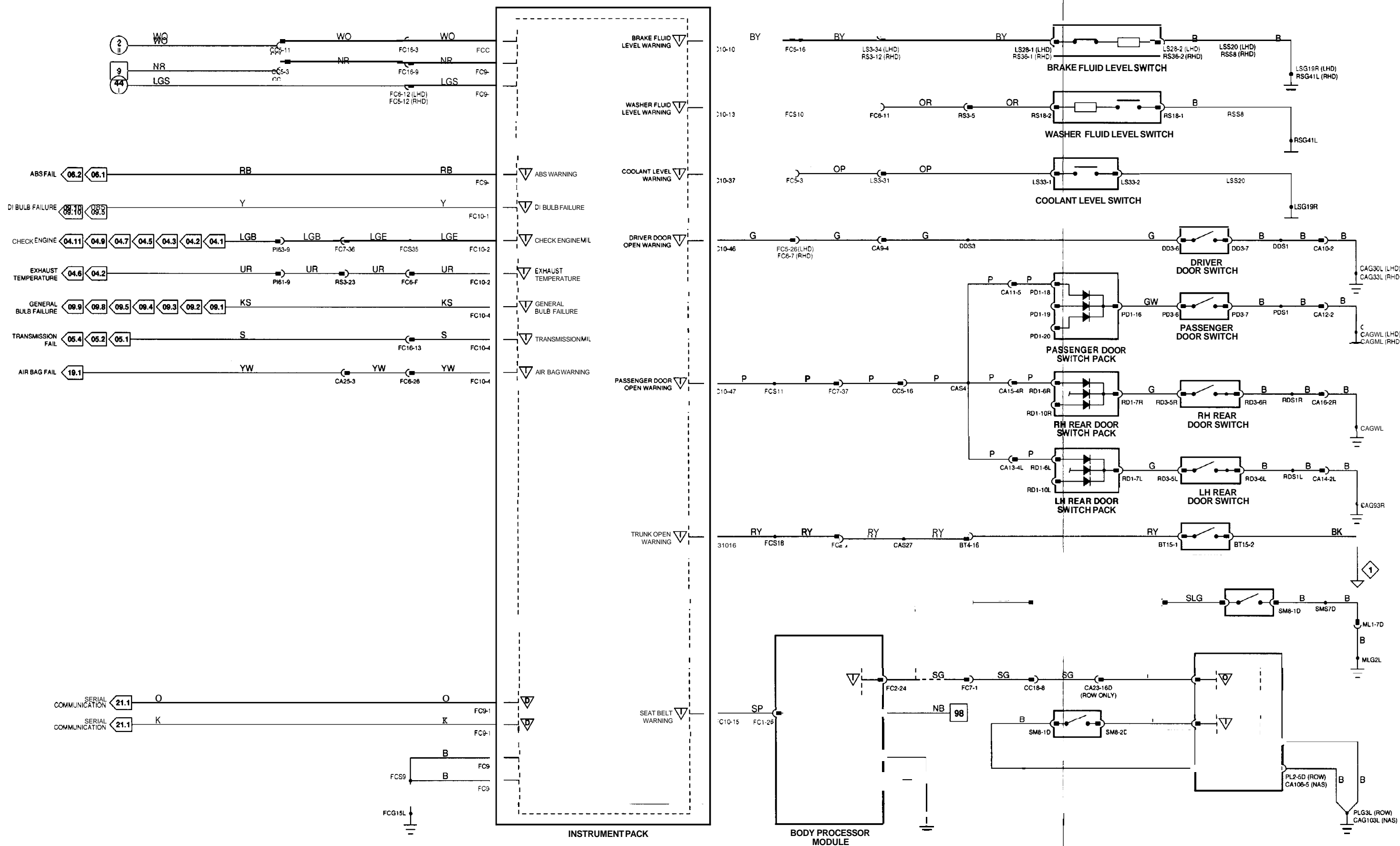

**CONTROL MODULE PIN OUT INFORMATION**

**BODY PROCESSOR MODULE**

Pin	Description	Active	Inactive
O FC1-21	AUDIBLE TONE SPEAKER		
O FC1-22	AUDIBLE TONE SPEAKER		
I FC2-3	SIDE LAMPS ON	GROUND	B+
I FC2-4	VEHICLE SPEED SENSOR	GROUND PULSE@ 10 MPH (16 KPH) = 20 Hz, 20 MPH (32 KPH) = 40 Hz	
I FC2-16	NOT IN PARK MICRO SWITCH	GROUND	B+
I FC2-18	RH DI REQUEST	GROUND	B+
I FC2-24	SEAT BELT WARNING LAMP	GROUND	B+
I FC2-25	SEAT MEMORY AUDIBLE WARNING	GROUND	B+
I FC2-27	HAZARD LAMPS REQUEST	GROUND	B+
I FC2-33	DRIVER DOOR AJAR	GROUND	B+
I FC2-46	LH DI REQUEST	GROUND	B+
I FC2-48	KEY IN IGNITION SWITCH	GROUND	B+

**DRIVER SEAT CONTROL MODULE (NAS)**

Pin	Description	Active	Inactive
O CA106-20	SEAT BELT WARNING	GROUND	B+
I SM6-21D	SEAT BELT FASTENED	GROUND	B+

**DRIVER SEAT CONTROL MODULE (ROW)**

Pin	Description	Active	Inactive
O PL1-20D	SEAT BELT WARNING	GROUND	B+
I SM6-21D	SEAT BELT FASTENED	GROUND	B+

**COMPONENTS**

Component	Connector	Type	Color	Location	Access
BODY PROCESSOR MODULE	FC1	48-WAY PCB SIGNAL	YELLOW	PASSENGER'S UNDERSCUTTLE	
	FC2	48-WAY PCB SIGNAL	BLACK		
	FC3	6-WAY PCB SIGNAL	BLACK		
CENTER CONSOLE SWITCH PACK	CC1	16-WAY MULTILOCK	040 / BLACK	CENTER CONSOLE	
DIRECTION INDICATOR SWITCHES (COLUMN SWITCHGEAR)	SC3	6-WAY MULTILOCK	070 / WHITE	STEERING COLUMN / COVER	
DOOR SWITCH - DRIVER	DD3	13-WAY ECONOSEAL	111 LC / BLACK	DOOR CASING	
DOOR SWITCH PACK - DRIVER	DD1	12-WAY MULTILOCK	41 / WHITE	ARM REST/TOP ROLL	
	DD2	12-WAY MULTILOCK	47 / WHITE		
SEAT CONTROL MODULE - DRIVER (NAS VEHICLES)	CA106	122-WAY MULTILOCK	47 / BLUE	DRIVERS SEAT	
	CA106	112-WAY MULTILOCK	47 / BLUE		
	SM1-D	12-WAY MULTILOCK	47 / WHITE		
	SM6	122-WAY MULTILOCK	41 / WHITE		
SEAT CONTROL MODULE - DRIVER (ROW, MEMORY SEAT VEHICLES)	PL1	122-WAY MULTILOCK	47 / BLUE	DRIVER'S SEAT	
	PL2	112-WAY MULTILOCK	47 / BLUE		
	SM1-D	12-WAY MULTILOCK	47 / WHITE		
	SM6-D	22-WAY MULTILOCK	47 / WHITE		
IGNITION SWITCH	FC54 (FLY LEAD)	18-WAY MULTILOCK	070 / WHITE	STEERING COLUMN / COVER	
LIGHTING SWITCHES	FC12	116-WAY MULTILOCK	040 / BLUE	FASCIA SWITCH PACK	
NOT IN PARK MICRO SWITCH	CC42 (FLY LEAD)	12-WAY MULTILOCK	040 / BLACK	'J' GATE / CENTER CONSOLE	
SEAT BELT SWITCH	SM6	12-WAY MULTILOCK	10D / BLACK	DRIVERS SEAT / UNDER	
SPEAKER (COLUMN SWITCHGEAR)	SC4	3-WAY MULTILOCK	070 / WHITE	STEERING COLUMN / COVER	

**HARNESS-TO-HARNESS CONNECTORS**

Connector	Type	Color	Location / Access
CA6	20-WAY MULTILOCK	10D / GREEN	DRIVER'S UNDERSCUTTLE
CA10	6-WAY MULTILOCK	070 / WHITE	DRIVER'S UNDERSCUTTLE
CA23	20-WAY MULTILOCK	040 / BLACK	DRIVER'S SEAT
CC3	20-WAY MULTILOCK	040 / BLACK	CENTER CONSOLE / CENTER CONSOLE GLOVE BOX
CC18	20-WAY MULTILOCK	10D / BLUE	CENTER CONSOLE / CENTER CONSOLE
FC4	20-WAY MULTILOCK	10 / BLUE	DRIVER'S UNDERSCUTTLE
FC5	THROUGH-PANEL	146 MICRO / 6 / BLACK	LH FASCIA END PANEL / OUTER AIR VENT
FC6	THROUGH-PANEL	146 MICRO / 6 / BLACK	RH FASCIA END PANEL / OUTER AIR VENT
FC7	THROUGH-PANEL	148 MICRO / 6 / BLACK	PASSENGERS UNDERSCUTTLE
FC16	20-WAY MULTILOCK	040 / BLACK	PASSENGERS UNDERSCUTTLE
ML1-D	10-WAY MULTILOCK	010 / WHITE	DRIVER'S SEAT / UNDER

**GROUNDS**

Ground	Location	Type
CAG30L	LH 'A' POST	GROUND SCREW
CAG33L	RH HEELBOARD	GROUND SCREW
CAG103L	LH SEAT	GROUND STUD
CCG51L	CENTER CONSOLE	GROUND STUD
FCG15L	LH CONSOLE	GROUND STUD
FCG26R	LH CONSOLE	GROUND STUD
MLG2L	LH SEAT	GROUND SCREW
PLG3L	LH SEAT	GROUND SCREW

**CONTROL MODULE PIN OUT INFORMATION (FOLD OUT PAGE)**



The following symbols are used to represent values for Control Module Pin Out data:

- I Input
- O output
- SG Signal Ground
- D Serial and encoded communications
- B+ Battery voltage
- V Voltage (DC)
- Hz Frequency
- KHz Frequency x IOW
- MS Milliseconds
- MV Millivolts

CAUTION: The information on this data page is furnished to aid the user in understanding circuit operation. THIS INFORMATION SHOULD BE USED FOR REFERENCE ONLY.

NOTE: The values listed are approximately those that can be expected at the control module connector pins with all circuit connections made and all components connected and fitted. "Active" means a load is applied or a switch is ON; "Inactive" means a load is not applied or a switch is OFF.

REFER TO THE FRONT OF THE BOOK FOR ILLUSTRATIONS DETAILING THE LOCATION AND IDENTIFICATION OF COMPONENTS, RELAYS, CONNECTORS, HARNESSES, GROUNDS, VEHICLE CONTROL MODULES AND CONTROL MODULE PINS.

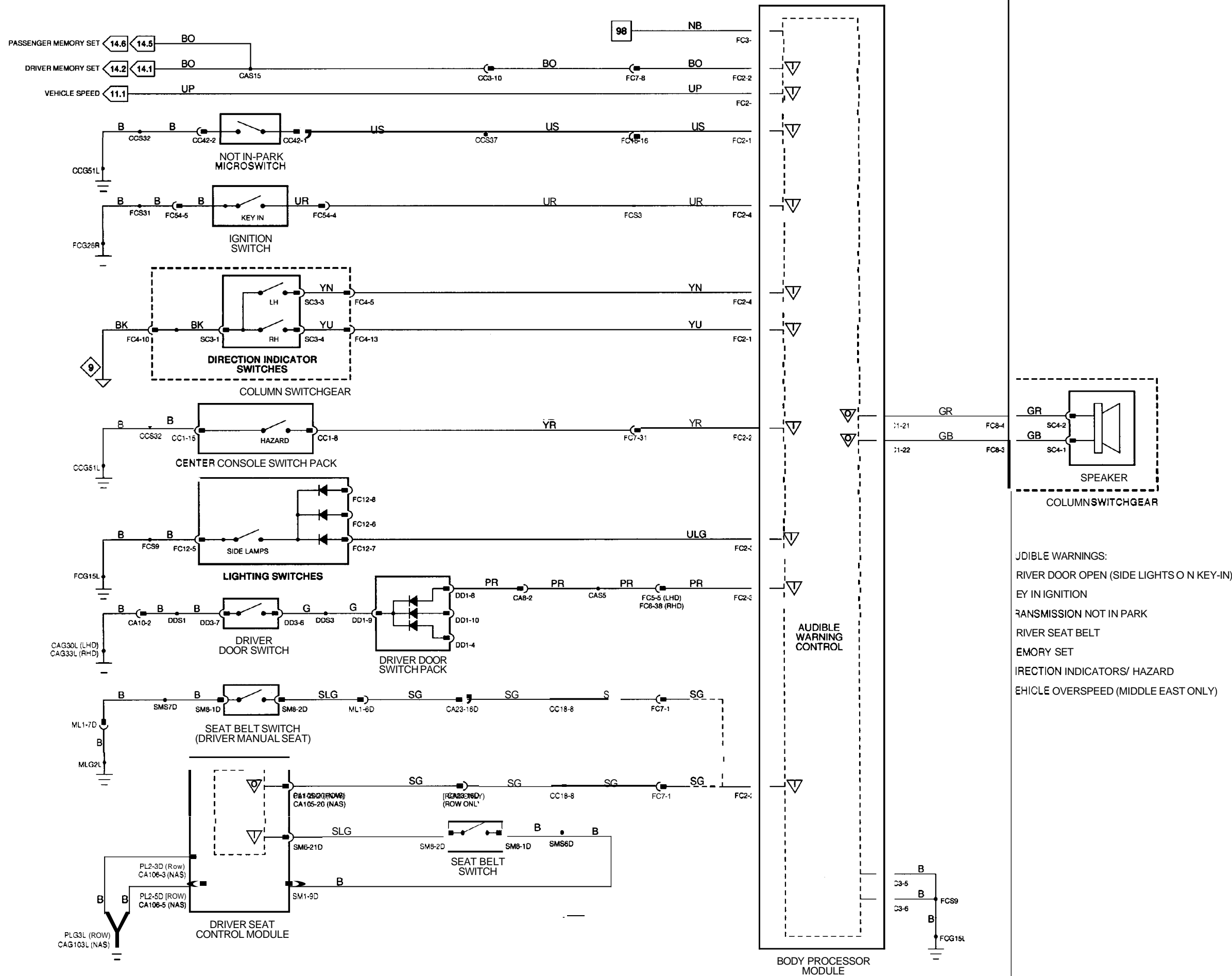

**AUDIBLE WARNINGS:**

- DRIVER DOOR OPEN (SIDE LIGHTS ON KEY-IN)
- KEY IN IGNITION
- TRANSMISSION NOT IN PARK
- DRIVER SEAT BELT
- MEMORY SET
- DIRECTION INDICATORS/ HAZARD
- VEHICLE OVERSPEED (MIDDLE EAST ONLY)

## CONTROL MODULE PIN OUT INFORMATION

### AIR CONDITIONING CONTROL MODULE

Pin	Description	Active	Inactive
I CC28-1	COMPRESSOR CLUTCH ON SIGNAL	B+	GROUND
O CC28-6	DEFROST VENT SERVO MOTOR	B+	GROUND
O ccm-7	CENTER VENT SERVO MOTOR	B+	GROUND
O CC28-8	LH RECIRCULATION VENT SERVO MOTOR	B+	GROUND
O CC28-9	RH RECIRCULATION VENT SERVO MOTOR	B+	GROUND
O CC28-12	FOOTWELL VENT SERVO MOTOR	B+	GROUND
O CC28-13	COOL AIR BY-PASS VENT SERVO MOTOR	B+	GROUND
O CC28-19	DEFROST VENT SERVO MOTOR	B+	GROUND
O CC28-20	CENTER VENT SERVO MOTOR	B+	GROUND
O CC28-21	LH RECIRCULATION VENT SERVO MOTOR	B+	GROUND
O CC28-22	RH RECIRCULATION VENT SERVO MOTOR	B+	GROUND
O CC28-25	FOOTWELL VENT SERVO MOTOR	B+	GROUND
O CC28-26	COOL AIR BY-PASS VENT SERVO MOTOR	B+	GROUND
I CC29-1	SOLAR SENSOR FEEDBACK VOLTAGE	0.75 ~ 4.75 V, INCREASING WITH LAMP BRIGHTNESS	
I CC29-2	CENTER VENT POTENTIOMETER FEEDBACK VOLTAGE	> 3.5 V (OPEN)	< 1 V (CLOSED)
I CC29-3	RH RECIRCULATION POTENTIOMETER FEEDBACK VOLTAGE	> 3.5 V (OPEN)	< 1 V (CLOSED)
I CC29-5	COOL AIR BY-PASS POTENTIOMETER FEEDBACK VOLTAGE	> 3.5 V (OPEN)	< 1 V (CLOSED)
I CC29-6	COOLANT TEMPERATURE SIGNAL	2.5 V @ 90° C, INCREASING WITH TEMPERANRE	
I CC29-9	TEMPERATURE DIFFERENTIAL POTENTIOMETER FEEDBACK	0.75V = RED; 4.75V = BLUE	
I CC29-10	DEFROST VENT POTENTIOMETER FEEDBACK	> 3.5 V (OPEN)	< 1 V (CLOSED)
I CC29-11	LH RECIRCULATION POTENTIOMETER FEEDBACK	> 3.5 V (OPEN); < 1 V (CLOSED)	
I CCB-13	FOOTWELL VENT POTENTIOMETER FEEDBACK	> 3.5 V (OPEN); < 1 V (CLOSED)	
O ccm-1	AIR CONDITIONING ELECTRICAL LOAD SIGNAL	B+	GROUND
O CCM-2	CLOCK	B+ 11.46 KHz	B+
D CC30-3	SERIAL DATA OUTPUT TO CONTROL PANEL		
I CC30-5	AMBIENT TEMPERATURE SENSOR FEEDBACK	2.18 V @ 25° C, INCREASING WITH TEMPERATURE	
I CCM-6	HEATER MATRIX AIR TEMPERATURE SENSOR FEEDBACK	2.25 V @ 20° C, INCREASING WITH TEMPERATURE	
D CC30-7	SERIAL DATA INPUT FROM CONTROL PANEL		
O CC30-8	START	B+	GROUND
I CCM-11	IN-CAR TEMPERATURE SENSOR FEEDBACK	3.25 V @ 0° C, INCREASING WITH TEMPERATURE	
I CCM-12	EVAPORATOR TEMPERATURE SENSOR FEEDBACK	3.25 V @ 0° C, INCREASING WITH TEMPERATURE	
I CC31-3	IGNITION SWITCHED GROUND	GROUND	B+
O CC31-4	IGNITION SWITCHED POWER SUPPLY TO CONTROL PANEL	B+	GROUND
I CC31-6	ENGINE SPEED SIGNAL	5 V @ 1000 RPM = 45 Hz, 2000 RPM = 90 Hz	
O CC31-8	SERVO POTENTIOMETER COMMON REFERENCE VOLTAGE	5V	5 V
O CC31-9	COMPRESSOR CLUTCH REQUEST	GROUND	B+
D CC31-10	SERIAL COMMUNICATION INPUT		
O CC31-12	BATTERY POWER SUPPLY TO CONTROL PANEL	B+	B+
O CC31-15	AIR CONDITIONING ISOLATE RELAY	B+	GROUND
I CC31-16	VEHICLE SPEED SIGNAL	B+ @ 10 MPH (16 KPH) = 20 Hz, 20 MPH (32 KPH) = 40 Hz	B+
I CC31-17	REFRIGERANT TRIPLE PRESSURE SWITCH - 4.0L REFRIGERANT DUAL PRESSURE SWITCH - V12	GROUND	B+
O CC31-18	ASPIRATOR MOTOR	B+	GROUND
SG CC31-19	SERVO POTENTIOMETER COMMON REFERENCE GROUND	GROUND	GROUND
D CC31-21	SERIAL COMMUNICATION OUTPUT		

### AIR CONDITIONING CONTROL PANEL

Pin	Description	Active	Inactive
I CC2-1	CLOCK	B+ 11.46 KHz	B+
I CC2-2	START	B+	GROUND
D CC2-3	SERIAL DATA OUTPUT TO A/C CONTROL MODULE		
D CC2-4	SERIAL DATA INPUT FROM A/C CONTROL MODULE		
I CC2-5	IGNITION SWITCHED POWER SUPPLY	B+	GROUND
I CC2-6	BATTERY POWER SUPPLY	B+	B+

The following symbols are used to represent values for Control Module Pin Out data.

<b>I</b> Input	<b>B+</b> Battery voltage
<b>O</b> Output	<b>V</b> Voltage (DC)
<b>SG</b> Signal Ground	<b>Hz</b> Frequency
<b>D</b> Serial and encoded communications	<b>KHz</b> Frequency x 1000
	<b>MS</b> Milliseconds
	<b>MV</b> Millivolts

**CAUTION:** The information on this data page is furnished to aid the user in understanding circuit operation. THIS INFORMATION SHOULD BE USED FOR REFERENCE ONLY.

**NOTE:** The values listed are approximately those that can be expected at the control module connector pins with all circuit connections made and all components connected and fitted. "Active" means a load is applied or a switch is ON; "Inactive" means a load is not applied or a switch is OFF.

## Fig. 12.1

### COMPONENTS

Component	Connector / Type / Color	Location / Access
AIR CONDITIONING CONTROL MODULE	CC28 126-WAY MULTILOCK 47 / SLATE CC29 16-WAY MULTILOCK 47 / SLATE CC30 112-WAY MULTILOCK 47 / SLATE CC31 122-WAY MULTILOCK 47 / SLATE	A/C UNIT, RH SIDE / RH UNDERSCUTTLE
AIR CONDITIONING CONTROL PANEL	CC2 (FLY LEAD) 112-WAY MULTILOCK 040 / BLUE	CENTER CONSOLE
AMBIENT TEMPERATURE SENSOR	BL6 (FLY LEAD) 12-WAY ECONOSEAL III LC I BLACK	LH FRONT WHEEL ARCH LINER / SPOILER TRAY
ASPIRATOR MOTOR	FC40 (FLY LEAD) 14-WAY MULTILOCK 070 / WHITE	DRIVERS UNDERSCUTTLE
COOL AIR BYPASS SERVO	CC34 (FLY LEAD) 12-WAY MULTILOCK 040 / BLACK	A/C UNIT, LH SIDE / LH UNDERSCUTTLE
DEFROST SERVO	FC42 (FLY LEAD) 112-WAY MULTILOCK 040 / BLACK	A/C UNIT, RH SIDE / FASCIA
DIFFERENTIAL CONTROL POTENTIOMETER	FC20 (FLY LEAD) 3-WAY MULTILOCK 070 / WHITE	A/C UNIT, LH SIDE / FASCIA
EVAPORATOR TEMPERATURE SENSOR	CC34 (FLY LEAD) 12-WAY MULTILOCK 040 / BLACK	A/C UNIT, LH SIDE / LH UNDERSCUTTLE
FOOTWELL SERVO	CC34 (FLY LEAD) 12-WAY MULTILOCK 040 / BLACK	A/C UNIT, LH SIDE / LH UNDERSCUTTLE
FRESH RECIRCULATION SERVO - LH	CC32 (FLY LEAD) 15-WAY SUMITOMO 90 / GREEN	BLOWER HOUSING
FRESH RECIRCULATION SERVO - RH	CC33 (FLY LEAD) 15-WAY SUMITOMO 90 / GREEN	BLOWER HOUSING
HEATER MATRIX TEMPERATURE SENSOR	CC34 (FLY LEAD) 12-WAY MULTILOCK 040 / BLACK	A/C UNIT, LH SIDE / LH UNDERSCUTTLE
IN-CAR TEMPERATURE SENSOR	FC40 (FLY LEAD) 4-WAY MULTILOCK 040 / WHITE	DRIVERS UNDERSCUTTLE
SOLAR SENSOR	FC34 (FLY LEAD) 12-WAY MULTILOCK 040 / BLACK	FASCIA, TOP FRONT
VENT SERVO	FC42 (FLY LEAD) 12-WAY MULTILOCK 040 / BLACK	A/C UNIT, LH SIDE / LH UNDERSCUTTLE

### RELAYS

Relay	Color / Stripe	Connector / Color	Location / Access
AIR CONDITIONING ISOLATE RELAY	BLACK / BLUE	CA57 / BLUE	RH HEELBOARD

### HARNESS-TO-HARNESS CONNECTORS

Connector	Type / Color	Location / Access
BL1	13 WAY ECONOSEAL III LC I BLACK	LH FRONT WHEEL ARCH LINER / SPOILER AND SPOILER TRAY
CC5	20-WAY MULTILOCK 040 / GREEN	CENTER CONSOLE / CENTER CONSOLE GLOVE BOX
CC18	20-WAY MULTILOCK 040 / BLUE	CENTER CONSOLE / CENTER CONSOLE
FC5	THROUGH-PANEL (48 MICRO / 6) / BLACK	LH FASCIA END PANEL / OUTER AIR VENT
FC6	THROUGH-PANEL (48 MICRO / 6) / BLACK	RH FASCIA END PANEL / OUTER AIR VENT
FC7	THROUGH-PANEL (48 MICRO / 6) / BLACK	PASSENGERS UNDERSCUTTLE
FC16	20-WAY MULTILOCK 040 / BLACK	PASSENGERS UNDERSCUTTLE
LS3	THROUGH-PANEL (48 MICRO / 6) / BLACK	LH 'A' POST / 'A' POST PANEL
PI63	20 WAY MULTILOCK 040 / BLACK	RH 'A' POST / 'A' POST TRIM

### GROUNDS

Ground	Location / Type
CAG92R	RH HEELBOARD GROUND SCREW
CCG49L	RH CONSOLE GROUND STUD
CCG49R	RH CONSOLE GROUND STUD
FCG15R	LH CONSOLE GROUND STUD
PIG153L	RH BULKHEAD GROUND STUD

### CONTROL MODULE PIN OUT INFORMATION (FOLD OUT PAGE)



REFER TO THE FRONT OF THE BOOK FOR ILLUSTRATIONS DETAILING THE LOCATION AND IDENTIFICATION OF COMPONENTS, RELAYS, CONNECTORS, HARNESSSES, GROUNDS, VEHICLE CONTROL MODULES AND CONTROL MODULE PINS.



NOTE WHEN THE IGNITION SWITCHED GROUND INPUT IS INTERRUPTED DURING ENGINE CRANKING, THE NCCM DOES NOT DRIVE HIGH POWER CONSUMING COMPONENTS.

NOTE: THE A/C ISOLATE RELAY REMAINS ENERGIZED BY THE A/C CM FOR 30 SECONDS AFTER THE IGNITION IS SWITCHED OFF TO PROVIDE POWER FOR THE A/C CM TO "PARK" THE SERVOS.

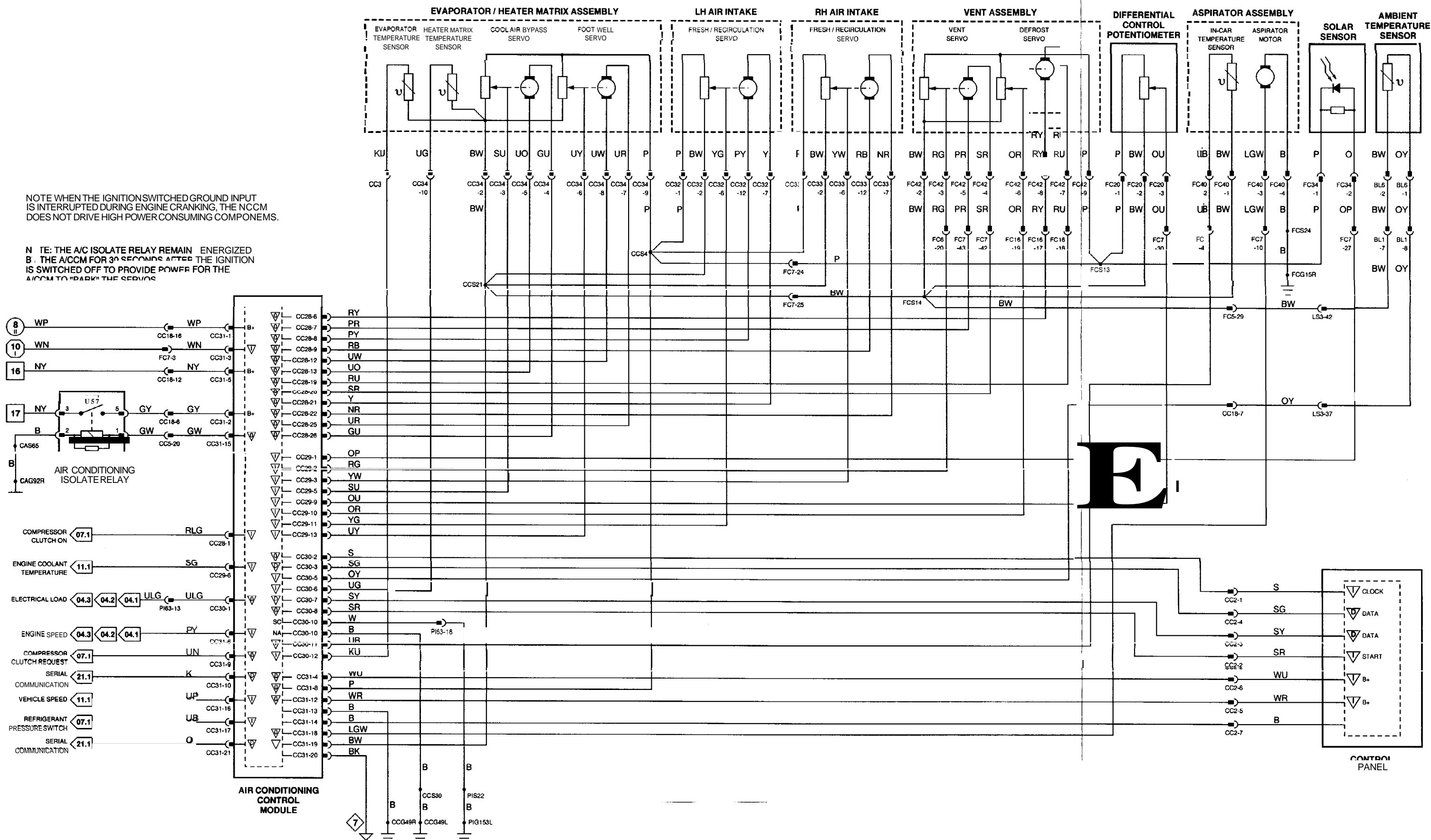

**CONTROL MODULE PIN OUT INFORMATION**

**AIR CONDITIONING CONTROL MODULE**

Pin	Description	Active	Inactive
I CC28-1	COMPRESSOR CLUTCH ON SIGNAL	B+	GROUND
O CC28-6	DEFROST VENT SERVO MOTOR	B+	GROUND
O CC28-7	CENTER VENT SERVO MOTOR	B+	GROUND
O CC28-8	LH RECIRCULATION VENT SERVO MOTOR	B+	GROUND
O CC28-9	RH RECIRCULATION VENT SERVO MOTOR	B+	GROUND
O CC28-12	FOOTWELL VENT SERVO MOTOR	B+	GROUND
O CC28-13	CDOL AIR BY-PASS VENT SERVO MOTOR	B+	GROUND
O CC28-19	DEFROST VENT SERVO MOTOR	B+	GROUND
O CC28-20	CENTER VENT SERVO MOTOR	B+	GROUND
O CC28-21	LH RECIRCULATION VENT SERVO MOTOR	B+	GROUND
O CC28-22	RH RECIRCULATION VENT SERVO MOTOR	B+	GROUND
O CC28-25	FOOTWELL VENT SERVO MOTOR	B+	GROUND
O CC28-26	COOL AIR BY-PASS VENT SERVO MOTOR	B+	GROUND
I CC29-1	SOLAR SENSOR FEEDBACK VOLTAGE	0.75 ~ 4.75 V, INCREASING WITH LAMP BRIGHTNESS	
I CC29-2	CENTER VENT WTENTIOMETER FEEDBACK VOLTAGE	> 35 V (OPEN)	< 1 V (CLOSED)
I CC29-3	RH RECIRCULATION POTENTIOMETER FEEDBACK VOLTAGE	> 3.5 V (OPEN)	< 1 V (CLOSED)
I CC29-5	COOL AIR BY-PASS POTENTIOMETER FEEDBACK VOLTAGE	> 3.5 V (OPEN)	< 1 V (CLOSED)
I CC29-6	COOLANT TEMPERATURE SIGNAL	2.5 V @ 90° C, INCREASING WITH TEMPERATURE	
I CC29-9	TEMPERATURE DIFFERENTIAL POTENTIOMETER FEEDBACK	0.75V ■ RED; 4.75V ■ BLUE	
I CC29-10	DEFROST VENT POTENTIOMETER FEEDBACK	> 3.5 V (OPEN)	< 1 V (CLOSED)
I CC29-11	LH RECIRCULATION WTENTIOMETER FEEDBACK	> 3.5 V (OPEN); < 1 V (CLOSED)	
I CC29-13	FOOTWELL VENT POTENTIOMETER FEEDBACK	> 3.5 V (OPEN); < 1 V (CLOSED)	
O CC30-1	AIR CONDITIONING ELECTRICAL LOAD SIGNAL	B+	GROUND
O CCM-2	CLOCK	B+ (1.45 KHz)	B+
D CCM-3	SERIAL DATA OUTPUT TO CONTROL PANEL		
I CC30-4	COMPRESSOR LOCK SIGNAL (V12 ONLY)	0.43 V	GROUND
I CCM-5	AMBIENT TEMPERATURE SENSOR FEEDBACK	2.18 V @ 25° C, INCREASING WITH TEMPERANRE	
I CC30-6	HEATER MATRIX AIR TEMPERATURE SENSOR FEEDBACK	2.26 V @ 20° C, INCREASING WITH TEMPERANRE	
D CCM-7	SERIAL DATA INPUT FROM CONTROL PANEL		
O CC30-8	START	B+	GROUND
I CC30-11	IN CAR TEMPERANRE SENSOR FEEDBACK	3.25 V @ 0° C, INCREASING WITH TEMPERATURE	
I CC30-12	EVAPORATOR TEMPERATURE SENSOR FEEDBACK	3.25 V @ 0° C, INCREASING WITH TEMPERANRE	
I CC31-3	IGNITION SWITCHED GROUND	GROUND	B+
O CC31-4	IGNITION SWITCHED POWER SUPPLY TO CONTROL PANEL	B+	GROUND
I CC31-6	ENGINE SPEED SIGNAL	5 V @ 1000 RPM = 45 Hz, 2000 RPM = 90 Hz	
I CC31-7	LOAD INHIBIT (V12 ONLY)	GROUND	B+
O CC31-8	SERVO POTENTIOMETER COMMON REFERENCE VOLTAGE	5V	5 v
O CC31-9	COMPRESSOR CLUTCH REQUEST	GRDUND	B+
D CC31-10	SERIAL COMMUNICATION INPUT		
O CC31-12	BATTERY POWER SUPPLY TO CONTROL PANEL	B+	B+
O CC31-15	AIR CONDITIONING ISOLATE RELAY	B+	GROUND
I CC31-16	VEHICLE SPEED SIGNAL	B+ @ 10 MPH (16 KPH) = 20 Hz, 20 MPH (32 KPH) = 40 Hz	
I CC31-17	REFRIGERANT TRIPLE PRESSURE SWITCH - 4 0L REFRIGERANT DUAL PRESSURE SWITCH - V12	GROUND	B+
O CC31-18	ASPIRATOR MOTOR	B+	GROUND
SG CC31-19	SERVO POTENTIOMETER COMMON REFERENCE GROUND	GROUND	GROUND
D CC31-21	SERIAL COMMUNICATION OUTPUT		

**AIR CONDITIONING CONTROL PANEL**

Pin	Description	Active	Inactive
I CC2-1	CLOCK	B+ (1.45 KHz)	B+
I CC2-2	START	B+	GROUND
D CC2-3	SERIAL DATA OUTPUT TO A/C CONTROL MODULE		
D CC2-4	SERIAL DATA INPUT FROM A/C CONTROL MODULE		
I CC2-5	IGNITION SWITCHED POWER SUPPLY	B+	GROUND
I CC2-6	BATTERY POWER SUPPLY	B+	B+

The following symbols are used to represent values for Control Module Pin Out data:

I	Input	B+	Battery voltage
O	Output	V	Voltage (DC)
SG	Signal Ground	Hz	Frequency
D	Serial and encoded communications	KHz	Frequency x 1000
		MS	Milliseconds
		MV	Millivolts

**CAUTION:** The information on this data page is furnished to aid the user in understanding circuit operation. THIS INFORMATION SHOULD BE USED FOR REFERENCE ONLY.

**NOTE:** The values listed are approximately those that can be expected at the control module connector pins with all circuit connections made and all components connected and fitted. "Active" means a load is applied or a switch is ON; "Inactive" means a load is not applied or a switch is OFF.

**Fig. 12.2**

**COMPONENTS**

Component	Connector / Type / Color	Location / Access
AIR CONDITIONING CONTROL MODULE	CC28 126-WAY MULTILOCK 47 / SLATE CC29 116-WAY MULTILOCK 47 / SLATE CC30 112-WAY MULTILOCK 47 / SLATE CC31 / 22-WAY MULTILOCK 41 / SLATE	A/C UNIT, RH SIDE RH UNDERSCUTTLE
AIR CONDITIONING CONTROL PANEL	CC2 (FLY LEAD) 112-WAY MULTILOCK 040 ■ BLUE	CENTER CONSOLE
AMBIENT TEMPERATURE SENSOR	BL6 (FLY LEAD) 12-WAY ECONOSEAL III LC / BLACK	LH FRONT WHEEL ARCH LINER ■ SPOILER TRAY
ASPIRATOR MOTOR	FC40 (FLY LEAD) 14-WAY MULTILOCK 070 ■ WHITE	DRIVERS UNDERSCUTTLE
COMPRESSOR LOCK SENSOR	PI57 (FLY LEAD) / 2-WAY ECONOSEAL III LC ■ BLACK	A/C COMPRESSOR
COOL AIR BYPASS SERVO	CC34 (FLY LEAD) 12-WAY MULTILOCK 040 / BLACK	A/C UNIT, LH SIDE: LH UNDERSCUTTLE
DEFROST SERVO	FC42 (FLY LEAD) 112-WAY MULTILOCK 040 ■ BLACK	A/C UNIT, RH SIDE: FASCIA
DIFFERENTIAL CONTROL WTENTIOMETER	FC20 (FLY LEAD) 13-WAY MULTILOCK 0701 WHITE	A/C UNIT, LH SIDE: FASCIA
EVAPORATOR TEMPERATURE SENSOR	CC34 (FLY LEAD) 112-WAY MULTILOCK 040 ■ BLACK	A/C UNIT, LH SIDE / LH UNDERSCUTTLE
FOOTWELL SERVO	CC34 (FLY LEAD) 112-WAY MULTILOCK 040 ■ BLACK	A/C UNIT, LH SIDE LH UNDERSCUTTLE
FRESH RECIRCULATION SERVO - LH	CC32 (FLY LEAD) 115-WAY SUMITOMO 90 ■ GREEN	BLOWER HOUSING
FRESH RECIRCULATION SERVO - RH	CC33 (FLY LEAD) 116-WAY SUMITOMO 901 GREEN	BLOWER HOUSING
HEATER MATRIX TEMPERATURE SENSOR	CC34 (FLY LEAD) 112-WAY MULTILOCK 040 ■ BLACK	A/C UNIT, LH SIDE LH UNDERSCUTTLE
IN CAR TEMPERATURE SENSOR	FC40 (FLY LEAD) 14-WAY MULTILOCK M 0 / WHITE	DRIVERS UNDERSCUTTLE
SOLAR SENSOR	FC34 (FLY LEAD) 12-WAY MULTILOCK 040 ■ BLACK	FASCIA, TOP FRONT
VENT SERVO	FC42 (FLY LEAD) 112-WAY MULTILOCK 040 ■ BLACK	A/C UNIT, LH SIDE / LH UNDERSCUTTLE

**RELAYS**

Relay	Color / Stripe	Connector / Color	Location / Access
AIR CONDITIONING ISOLATE RELAY	BLACK / BLUE	CAS7 / BLUE	RH HEELBOARD

**HARNESS-TO-HARNESS CONNECTORS**

Connector	Type / Color	Location / Access
BL1	13-WAY ECONOSEAL III LC / BLACK	LH FRONT WHEEL ARCH LINER ■ SPOILER AND SPOILER TRAY
CC5	20-WAY MULTILOCK M 0 ■ GREEN	CENTER CONSOLE / CENTER CONSOLE GLOVE BOX
CC18	20-WAY MULTILOCK 040 ■ BLUE	CENTER CONSOLE ■ CENTER CONSOLE
FC5	THROUGH-PANEL (48 MICRO / 6) ■ BLACK	LH FASCIA END PANEL ■ OUTER AIR VENT
FC6	THROUGH-PANEL (48 MICRO / 6) ■ BLACK	RH FASCIA END PANEL / OUTER AIR VENT
FC7	THROUGH-PANEL (48 MICRO / 6) ■ BLACK	PASSENGERS UNDERSCUTTLE
FC16	20-WAY MULTILOCK 040 ■ BLACK	PASSENGERS UNDERSCUTTLE
LS3	THROUGH-PANEL (48 MICRO / 6) ■ BLACK	LH 'A' POST / 'A' POST PANEL
PI1	13-WAY ECONOSEAL III LC I WHITE	RH AIR CLEANER
PI63	20-WAY MULTILOCK MO / BLACK	RH 'A' POST / 'A' POST TRIM

**GROUNDS**

Ground	Location / Type
CAG92R	RH HEELBOARD GROUND SCREW
CCG49R	RH CONSOLE GROUND S N D
FCG15R	LH CONSOLE GROUND S N D

**CONTROL MODULE PIN OUT INFORMATION (FOLD OUT PAGE)**



REFER TO THE FRONT OF THE BOOK FOR ILLUSTRATIONS DETAILING THE LOCATION AND IDENTIFICATION OF COMPONENTS, RELAYS, CONNECTORS, HARNESSES, GROUNDS, VEHICLE CONTROL MODULES AND CONTROL MODULE PINS.





NOTE WHEN THE IGNITION SWITCHED GROUND INPUT IS INTERRUPTED DURING ENGINE CRANKING, THE A/C DOES NOT DRIVE HIGH POWER CONSUMING COMPONE

NOTE THE A/C ISOLATE RELAY REMAINS ENERGIZED BY THE NCCM FOR 30 SECONDS AFTER THE IGNITION IS SWITCHED OFF TO PROVIDE POWER FOR THE NCCM TO "PARK THE SERVOS."

NOTE THE IGNITION SWITCHED POWER SUPPLY TO CC30-10 "SELECTS COMPRESSOR LOCK SENSING,

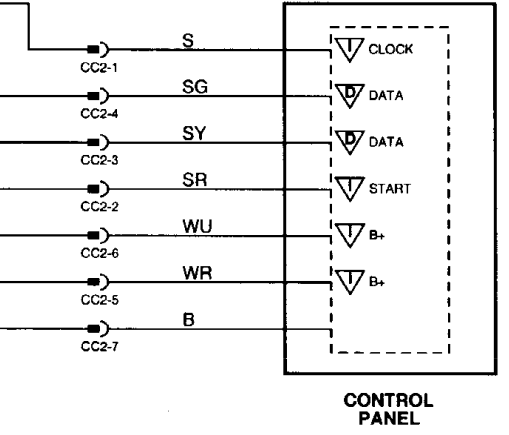
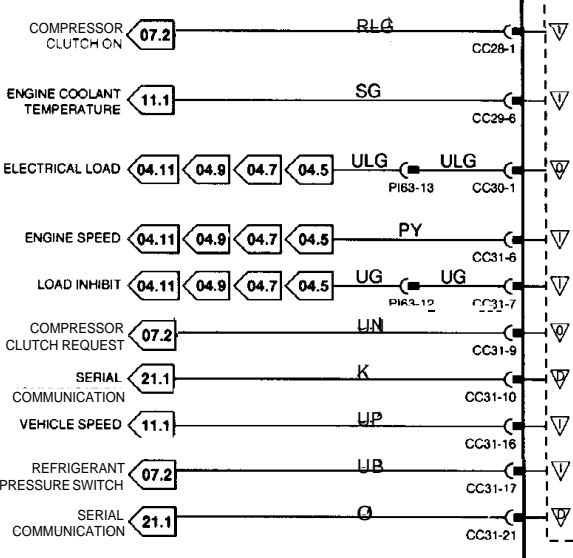
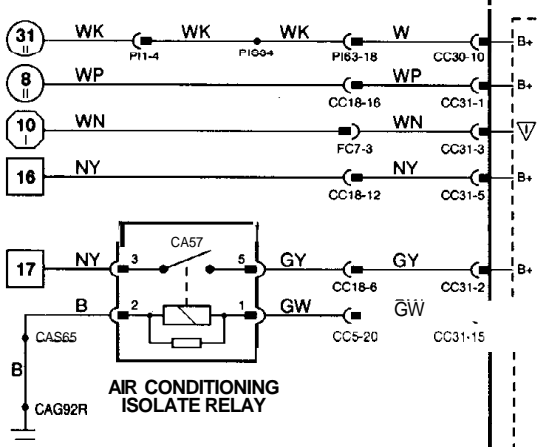
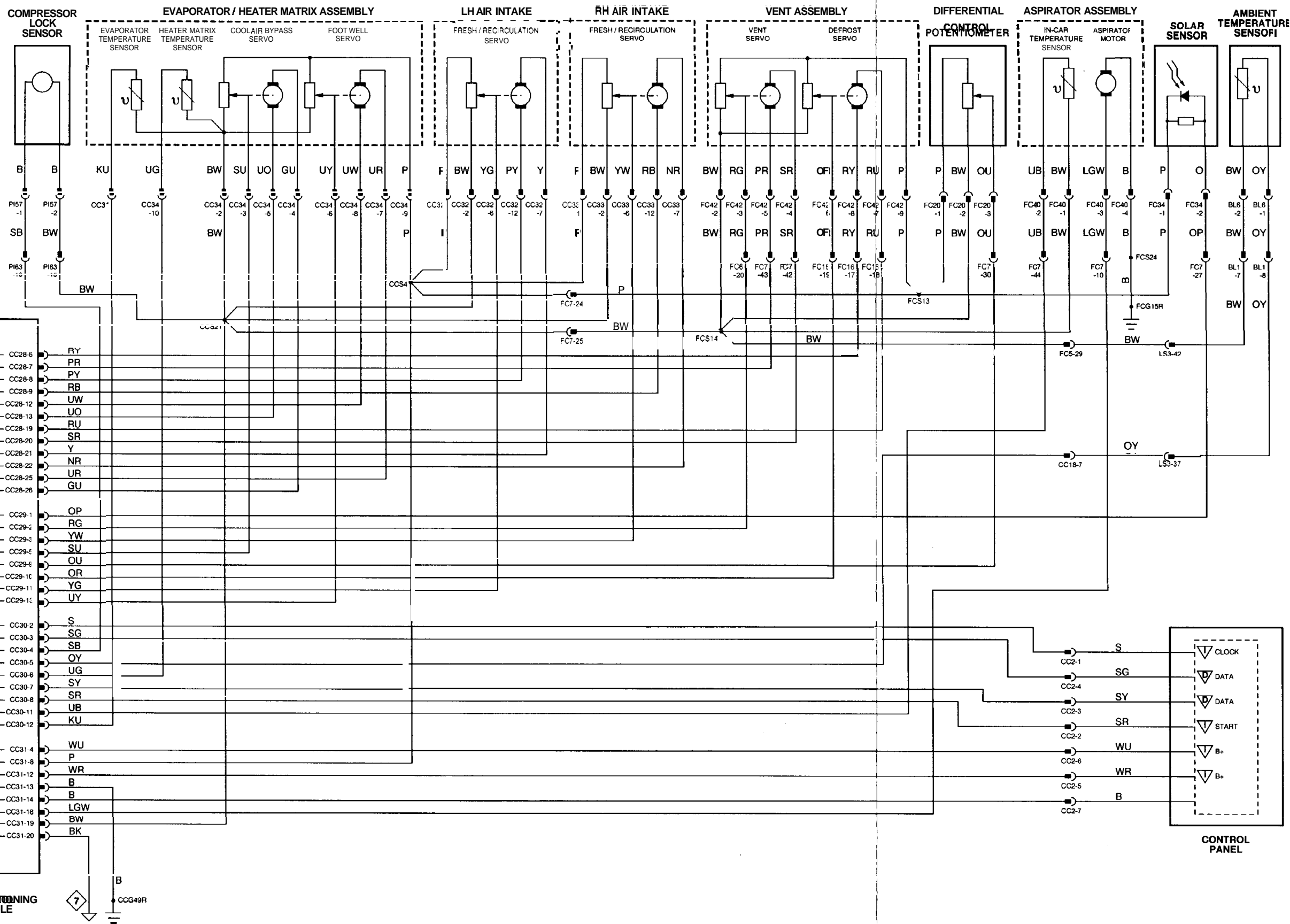

CONTROL MODULE PIN OUT INFORMATION

AIR CONDITIONING CONTROL MODULE

Pin	Description	Active	Inactive
o CC28-2	HEATER VALVE SUPPLY	B+	GROUND
o CC28-3	R/H BLOWER MOTOR RELAY	GROUND	B+
o CC28-4	LH AND RH WINDSHIELD HEATER RELAYS	GROUND	B+
o CC28-5	DOOR MIRROR HEATER RELAY	GROUND	B+
o CC28-14	RH HIGH SPEED BLOWER RELAY	GROUND	B+
o CC28-15	LH HIGH SPEED BLOWER RELAY	GROUND	B+
o CC28-16	LH BLOWER MOTOR RELAY	GROUND	B+
o CC28-17	HEATER PUMP RELAY	GROUND	B+
o CC28-18	HEATED BACKLIGHT RELAY	GROUND	B+
I CC29-7	RH BLOWER SPEED FEEDBACK	7.6 V = LOW SPEED; 0.83 V = HIGH SPEED	
o CC29-8	RH BLOWER SPEED CONTROL DRIVE SIGNAL	1.3 V = LOW SPEED; 0 V = HIGH SPEED	
I CC29-15	LH BLOWER SPEED FEEDBACK	7.6 V = LOW SPEED; 0.83 V = HIGH SPEED	
o CC29-16	LH BLOWER SPEED CONTROL DRIVE SIGNAL	1.3 V = LOW SPEED; 0 V = HIGH SPEED	
I CC31-3	IGNITION SWITCHED GROUND	GROUND	B+
I CC31-11	HEATER PUMP	GROUND	B+

Fig. 12.3

COMPONENTS

Component	Connector ■Type ■Color	Location ■Access
AIR CONDITIONING CONTROL MODULE	CC28 / 126-WAY MULTILOCK 47 / SLATE CC29 / 16-WAY MULTILOCK 47 / SLATE CC30 / 12-WAY MULTILOCK 47 / SLATE CC31 / 22-WAY MULTILOCK 47 / SLATE	A/C UNIT, RH SIDE / RH UNDERSCUTTLE
BLOWER MOTOR - LH	CC32 (FLY LEAD) 115-WAY SUMITOMO 090 / GREEN	LH UNDERSCUTTLE
BLOWER MOTOR - RH	CC33 (FLY LEAD) 15-WAY SUMITOMO 090 / GREEN	RH UNDERSCUTTLE
HEATED BACKLIGHT	CA17 / LUCAR / BLACK CA42 / LUCAR / BLACK	BACKLIGHT / LH 'E' POST TRIM BACKLIGHT / RH 'E' POST TRIM
HEATER PUMP	LS7 (FLY LEAD) 1 2-WAY ECONOSEAL 111 LC / BLACK	ENGINE BAY, LH REAR
HEATERVALVE	LS15 (FLY LEAD) 12-WAY ECONOSEAL 111 LC / WHITE	ENGINE BAY, LH REAR
MIRROR - DRIVER	DD10 / 12-WAY MULTILOCK 040 / BLACK	MIRROR ASSEMBLY
MIRROR - PASSENGER	PD10 / 12-WAY MULTILOCK 040 / BLACK	MIRROR ASSEMBLY
WINDSHIELD HEATER - LH	SH4 / 2-WAY SERIES 187C / SLATE	WINDSHIELD / WINDSHIELD BASE, ENGINE BAY
WINDSHIELD HEATER - RH	SH5 / 2-WAY SERIES 187C / SLATE	WINDSHIELD / WINDSHIELD BASE, ENGINE BAY

RELAYS

Relay	Color ■Stripe	Connector / Color	Location / Access
BLOWER MOTOR RELAY - LH	BLACK ■BLUE	CA59 / BLUE	RH HEELBOARD
BLOWER MOTOR RELAY - RH	BLACK / BLUE	CA58 / BLUE	RH HEELBOARD
DOOR MIRROR HEATER RELAY	VIOLET	CA54 / BLUE	RH HEELBOARD
HEATED BACKLIGHT RELAY	BLACK / VIOLET	BT42 / YELLOW	TRUNK ELECTRICAL CARRIER
HEATER PUMP RELAY	BLACK	LS46 / BLACK	LH ENGINE BAY RELAYS
HIGH SPEED RELAY - LH	BLACK / BLUE	CA59 ■BLUE	RH HEELBOARD
HIGH SPEED RELAY - RH	BLACK / BLUE	CA58 / BLUE	RH HEELBOARD
WINDSHIELD HEATER RELAY - LH	LIGHT BLUE	SH2 ■BLACK	LH 'A' POST
WINDSHIELD HEATER RELAY - RH	LIGHT BLUE	SH3 / BLACK	LH 'A' POST

HARNESS-TO-HARNESSCONNECTORS

Connector	Type / Color	Location / Access
BT4	THROUGH-PANEL (48 MICRO / 6) / BLACK	PARCEL SHELF ■FUEL TANK TRIM
CA3	20-WAY MULTILOCK 040 / BLACK	DRIVER'S 'A' POST / 'A' POST TRIM
CA10	8-WAY MULTILOCK 070 / WHITE	DRIVER'S UNDERSCUTTLE
CA11	20-WAY MULTILOCK 040 / BLACK	PASSENGER'S UNDERSCUTTLE / ECM
CA12	12-WAY MULTILOCK 070 / WHITE	PASSENGER'S UNDERSCUTTLE / ECM
CC3	20-WAY MULTILOCK 040 / BLACK	CENTER CONSOLE / CENTER CONSOLE GLOVE BOX
CC4	14-WAY MULTILOCK 070 / WHITE	CENTER CONSOLE / CENTER CONSOLE GLOVE BOX
CC5	20-WAY MULTILOCK 040 / GREEN	CENTER CONSOLE / CENTER CONSOLE
FC7	THROUGH-PANEL (48 MICRO / 6) / BLACK	PASSENGER'S UNDERSCUTTLE
LS3	THROUGH-PANEL (48 MICRO / 6) / BLACK	LH 'A' POST / 'A' POST PANEL
SH1	2-WAY SERIES 187C / SLATE	LH 'A' POST / 'A' POST PANEL
SH8	4-WAY MULTILOCK 070 / WHITE	LH 'A' POST / 'A' POST PANEL

GROUNDS

Ground	Location / Type
CAG30L	LH 'A' POST GROUND SCREW
CAG31L	PARCEL SHELF GROUND SCREW
CAG33L	RH HEELBOARD GROUND SCREW
CAG92L	RH HEELBOARD GROUND SCREW
CAG96L	LH HEELBOARD GROUND SCREW
CAG96R	LH HEELBOARD GROUND SCREW
CCG43L	RH CONSOLE GROUND STUD
CCG43R	RH CONSOLE GROUND STUD
CCG49L	RH CONSOLE GROUND STUD
CCG49R	RH CONSOLE GROUND STUD
LSG19L	LH BULKHEAD GROUND STUD
SHG6L	LH BULKHEAD GROUND STUD
SHG6R	LH BULKHEAD GROUND STUD

CONTROL MODULE PIN OUT INFORMATION (FOLD OUT PAGE)



The following symbols are used to represent values for Control Module Pin Out data:

I Input	B+ Battery voltage
O output	V Voltage (DC)
SG Signal Ground	Hz Frequency
D Serial and encoded communications	KHz Frequency x 1000
	MS Milliseconds
	MV Millivolts

CAUTION: The information on this data page is furnished to aid the user in understanding circuit operation. THIS INFORMATION SHOULD BE USED FOR REFERENCE ONLY.

NOTE: The values listed are approximately those that can be expected at the control module connector pins with all circuit connections made and all components connected and fitted. "Active" means a load is applied or a switch is ON; "Inactive" means a load is not applied or a switch is OFF.

REFER TO THE FROM OF THE BOOK FOR ILLUSTRATIONS DETAILING THE LOCATION AND IDENTIFICATION OF COMPONENTS, RELAYS, CONNECTORS, HARNESES, GROUNDS, VEHICLE CONTROL MODULES AND CONTROL MODULE PINS.



NOTE: WHEN IGNITION SWITCHED GROUND INPUT IS INTERRUPTED DURING ENGINE CRANKING, THE A/C/M HIGH POWER CONSUMING COMPONENTS.

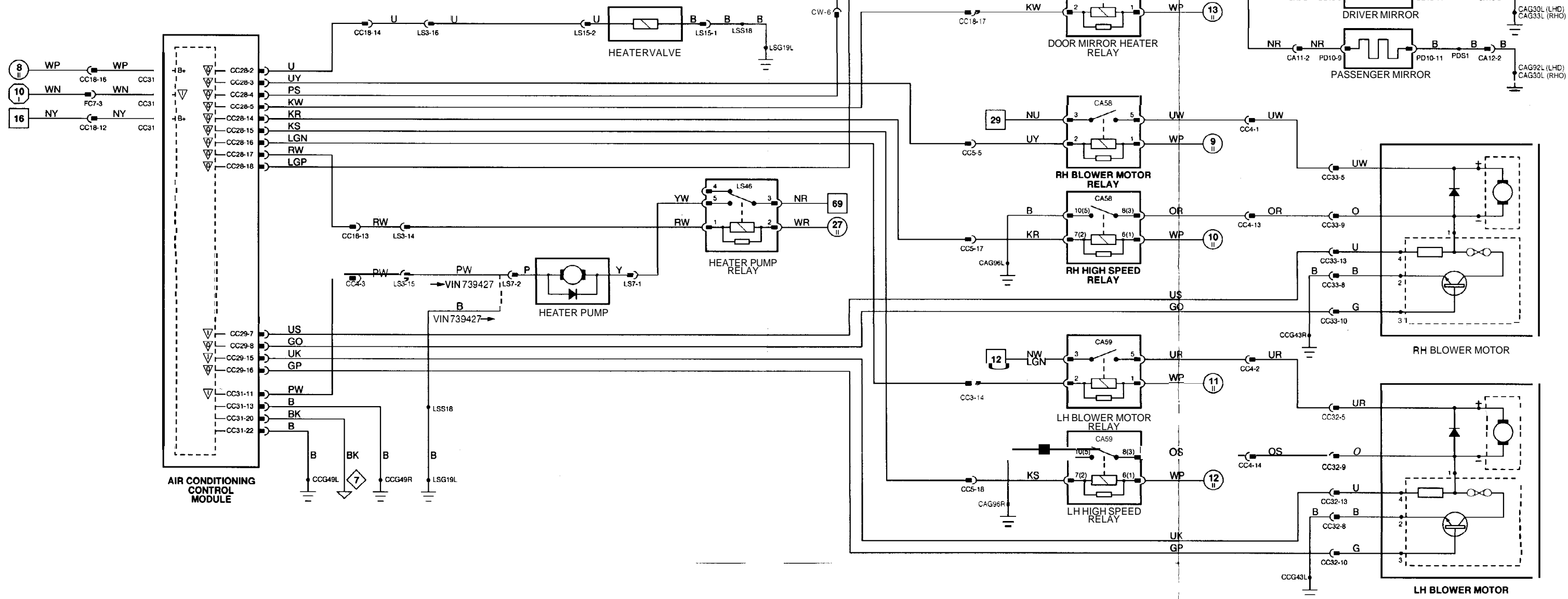

CONTROL MODULE PIN OUT INFORMATION

VARIABLE STEERING CONTROL MODULE

Pin	Description	Active	Inactive
O CA32-2	TRANSDUCER NEGATIVE	2 V @ IDLE, DECREASING WITH VEHICLE SPEED	
I CA32-4	VEHICLE SPEED	B+ @ 10 MPH (16 KPH) = 20 Hz, 20 MPH (32 KPH) = 40 Hz	
O CA32-5	TRANSDUCER POSITIVE	9 V @ IDLE, INCREASING WITH VEHICLE SPEED	

**Fig. 13.1**

COMPONENTS

Component	Connector / Type / Color	Location / Access
VARIABLE POWER STEERING CONTROL MODULE VARIABLE STEERING CONVERTER	CA32 15-WAY RISTS / BLACK LL3 / 2-WAY JUNIOR TIMER / BLACK	LH 'A' POST / 'A' POST TRIM STEERING RACK, PINION HOUSING

HARNESS-TO-HARNESS CONNECTORS

Connector	Type / Color	Location / Access
LL2	3-WAY ECONOSEAL III LC / BLACK	LH FRONT WHEEL ARCH LINER
LS3	THROUGH PANEL / 48 MICRO / 61 / BLACK	LH 'A' POST / 'A' POST PANEL
PI59	13-WAY ECONOSEAL III LC / BLACK	LH AIR CLEANER
PI61	13-WAY ECONOSEAL III LC / BLACK	RH AIR CLEANER

GROUNDS

Ground	Location / Type
CAG30R	LH 'A' POST GROUND SCREW

CONTROL MODULE PIN OUT INFORMATION (FOLD OUT PAGE)



The following symbols are used to represent values for Control Module Pin Out data:

- I Input
- O output
- SG Signal Ground
- D Serial and encoded communications
- B+ Battery voltage
- V Voltage (DC)
- Hz Frequency
- KHz Frequency x 1000
- MS Milliseconds
- MV Millivolts

CAUTION: The information on this data page is furnished to aid the user in understanding circuit operation. THIS INFORMATION SHOULD BE USED FOR REFERENCE ONLY.

NOTE: The values listed are approximately those that can be expected at the control module connector pins with all circuit connections made and all components connected and fitted. "Active" means a load is applied or a switch is ON; "Inactive" means a load is not applied or a switch is OFF.

REFER TO THE FRONT OF THE BOOK FOR ILLUSTRATIONS DETAILING THE LOCATION AND IDENTIFICATION OF COMPONENTS, RELAYS, CONNECTORS, HARNESES, GROUNDS, VEHICLE CONTROL MODULES AND CONTROL MODULE PINS.

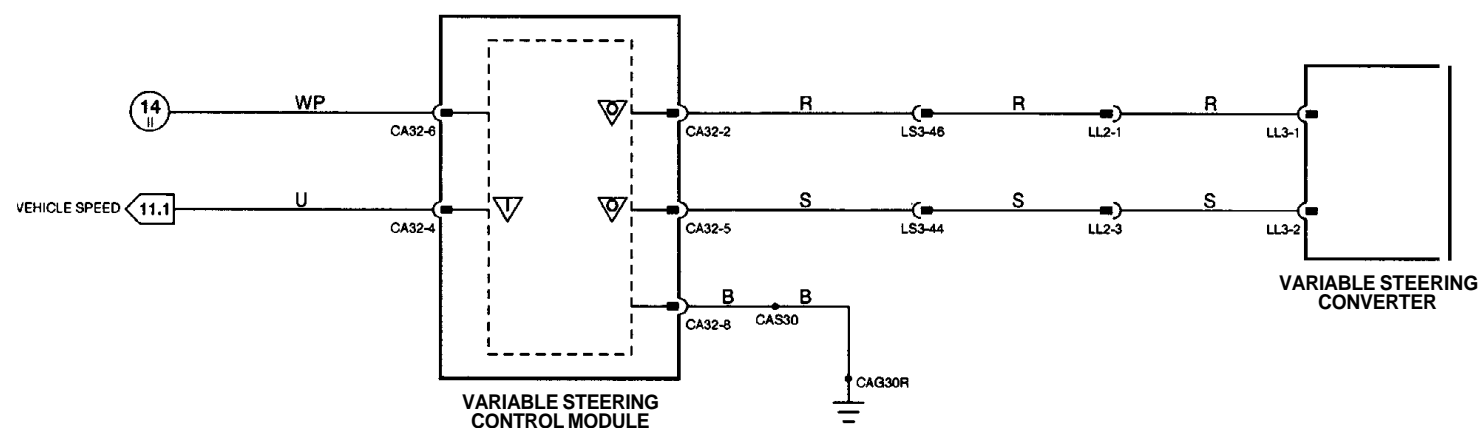

LHD

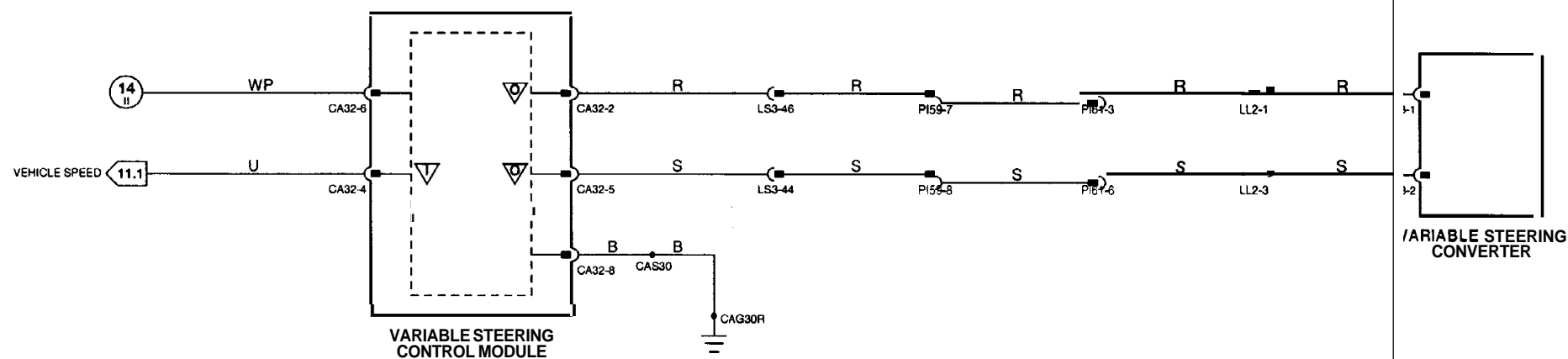

RHD

CONTROL MODULE PIN OUT INFORMATION

COLUMN / MIRROR MOVEMENT CONTROL MODULE

Pin	Description	Active	Inactive
o FC45-1	PASSENGER MIRROR UP / DOWN MOTOR	B+ (UP)	GROUND
o FC45-2	STEERING COLUMN TILT MOTOR	B+ IUPI	GROUND
o FC45-4	PASSENGER MIRROR RIGHT / LEFT POTENTIOMETER FEEDBACK	0.5 V (LEFT), 4 V (RIGHT)	
i FC45-5	STEERING COLUMN MOVEMENT JOYSTICK	6.8 V (OUT), 8.5 V (IN) 10.1 V IUPI, 12.1 V (DOWN)	GROUND
i FC45-6	PASSENGER MIRROR UP / DOWN REQUEST	B+ IUPI, GROUND (DOWN)	GROUND
i FC45-7	DRIVER MIRROR UP / DOWN REQUEST	B+ (UP), GROUND (DOWN)	OPEN CIRCUIT
i FC45-8	PASSENGER MIRROR RIGHT / LEFT REQUEST	B+ (RIGHT), GROUND (LEFT)	OPEN CIRCUIT
i FC45-9	DRIVER MIRROR RIGHT / LEFT REQUEST	B+ (RIGHT), GROUND (LEFT)	OPEN CIRCUIT
i FC45-10	MIRROR SELECT	SAME AS DIRECTIONAL REQUEST IN USE	OPEN CIRCUIT
o FC45-11	DRIVER MIRROR UP / DOWN MOTOR	B+ (UP)	
o FC45-12	STEERING COLUMN REACH MOTOR	B+ (IN)	GROUND
o FC45-13	DRIVER MIRROR RIGHT / LEFT MOTOR	B+ (RIGHT)	GROUND
o FC45-14	STEERING COLUMN TILT MOTOR	B+ (DOWN)	GROUND
o FC45-15	STEERING COLUMN REACH MOTOR	B+ (OUT)	GROUND
SG FC45-16	COLUMN AND MIRROR POTENTIOMETER COMMON REFERENCE GROUND	GROUND	GROUND
i FC45-17	MEMORY 3 SWITCH REQUEST	B+	GROUND
i FC45-18	MEMORY 2 SWITCH REQUEST	B+	GROUND
i FC45-19	MEMORY 1 SWITCH REQUEST	B+	GROUND
i FC45-20	MEMORY SET SWITCH REQUEST	B+	GROUND
i FC45-22	KEY IN IGNITION SWITCH SIGNAL	GROUND	B+
o FC45-23	IGNITION SWITCHED GROUND	GROUND	B+
o FC45-24	COLUMN AND MIRROR POTENTIOMETER COMMON REFERENCE VOLTAGE	5 v	5 v
o FC45-25	PASSENGER MIRROR RIGHT / LEFT MOTOR	B+ (RIGHT)	GROUND
o FC45-26	DRIVER AND PASSENGER MIRROR MOTORS COMMON	B+ (LEFT), GROUND (RIGHT)	GROUND
i FC46-1	DRIVER MIRROR RIGHT / LEFT POTENTIOMETER FEEDBACK	0.5 V (LEFT), 4 V (RIGHT)	
i FC46-2	PASSENGER MIRROR UP / DOWN POTENTIOMETER FEEDBACK	0.5 V (DOWN), 4 V IUPI	
i FC46-3	DRIVER MIRROR UP / DOWN POTENTIOMETER FEEDBACK	0.5 V (DOWN), 4 V (UP)	
i FC46-4	STEERING COLUMN TILT POTENTIOMETER FEEDBACK	0.5 V (DOWN), 4 V (UP)	
i FC46-5	STEERING COLUMN REACH POTENTIOMETER FEEDBACK	0.5 V (OUT), 4 V (IN)	
i FC46-6	IGNITION VOLTAGE	B+	GROUND
i FC46-7	AUTO / MANUAL TILT SELECTION SWITCH	GROUND = AUTO	B+ = OFF
i FC46-8	NOT IN PARK	GROUND	B+
i FC46-9	HANDBRAKE ON	GROUND	B+
i FC46-10	DRIVER DOOR AJAR	GROUND	7.9 V
i FC46-11	REMOTE SEAT / MIRROR / COLUMN REQUEST	GROUND PULSE	B+
D FC47-4	SERIAL COMMUNICATION OUTPUT		
D FC47-5	SERIAL COMMUNICATION INPUT		

The following symbols are used to represent values for Control Module Pin Out data:

I	Input	B+	Battery voltage
O	Output	V	Voltage (DC)
SG	Signal Ground	Hz	Frequency
D	Serial and encoded communications	KHz	Frequency x 1000
		MS	Milliseconds
		MV	Millivolts

CAUTION: The information on this data page is furnished to aid the user in understanding circuit operation. THIS INFORMATION SHOULD BE USED FOR REFERENCE ONLY.

NOTE: The values listed are approximately those that can be expected at the control module connector pins with all circuit connections made and all components connected and fitted. "Active" means a load is applied or a switch is ON; "Inactive" means a load is not applied or a switch is OFF.

COMPONENTS

Component	Connector / Type / Color	Location / Access
AUTO TILT SWITCH (COLUMN SWITCHGEAR) COLUMN / MIRROR MOVEMENT CONTROL MODULE	SC5 (FLY LEAD) / 8-WAY GROTE AND HARTMAN / BLACK FC45 126-WAY MULTILOCK 47 / SLATE FC46 / 16-WAY MULTILOCK 47 / SLATE FC47 112-WAY MULTILOCK 47 / SLATE	STEERING COLUMN / COVER RH UNDERSCUTTLE
COLUMN JOYSTICK (COLUMN SWITCHGEAR) DOOR MIRROR MOTORS - DRIVER DOOR MIRROR MOTORS - PASSENGER DOOR SWITCH - DRIVER DOOR SWITCH PACK - DRIVER	SC5 (FLY LEAD) 18-WAY GROTE AND HARTMAN / BLACK DD10 (FLY LEAD) / 12-WAY MULTILOCK MO / BLACK PD10 (FLY LEAD) / 12-WAY MULTILOCK MO / BLACK DD3 / 13-WAY ECONOSEAL III LC / BLACK DD1 / 12-WAY MULTILOCK 47 / WHITE DD2 / 12-WAY MULTILOCK 47 / WHITE	STEERING COLUMN / COVER MIRROR ASSEMBLY MIRROR ASSEMBLY DOOR CASING ARM REST TOP ROLL
HAND BRAKE SWITCH IGNITION SWITCH LINEAR GEAR POSITION SWITCHES NOT IN-PARK MICROSWITCH REVERSE SWITCH (AJ16) MANUAL 1 ROTARY SWITCH	CC52 / 2-WAY MULTILOCK 040 / BLACK FC54 (FLY LEAD) / 8-WAY MULTILOCK 070 / WHITE CC21 120-WAY MULTILOCK 040 / BLACK CC42 (FLY LEAD) / 2-WAY MULTILOCK 040 / BLACK CC45 / 2-WAY SUMITOMO / WHITE GB1 (FLY LEAD) / 8-WAY MULTILOCK 070 / WHITE GB2 (FLY LEAD) / 12-WAY MULTILOCK 040 / BLACK FC49 (FLY LEAD) / 8-WAY MULTILOCK 070 / WHITE FC50 (FLY LEAD) / 8-WAY MULTILOCK 070 / YELLOW	CENTER CONSOLE, LH SIDE STEERING COLUMN / COVER 'J' GATE / CENTER CONSOLE 'J' GATE / CENTER CONSOLE TRANSMISSION TUNNEL / CENTER CONSOLE 'J' GATE / CENTER CONSOLE
STEERING COLUMN MOTORS		STEERING COLUMN / DRIVERS UNDERSCUTTLE

HARNESSTO-HARNESCONNECTORS

Connector	Type / Color	Location / Access
CA8	20-WAY MULTILOCK 040 / GREEN	DRIVERS UNDERSCUTTLE
CA9	20-WAY MULTILOCK 040 / BLACK	DRIVERS 'A' POST / 'A' POST TRIM
CA10	8-WAY MULTILOCK 070 / WHITE	DRIVERS UNDERSCUTTLE
CA11	20-WAY MULTILOCK MO / BLACK	PASSENGER'S UNDERSCUTTLE / ECM
CA12	12-WAY MULTILOCK 0701 WHITE	PASSENGER'S UNDERSCUTTLE / ECM
CC3	20-WAY MULTILOCK MO / BLACK	CENTER CONSOLE / CENTER CONSOLE GLOVE BOX
FC4	20-WAY MULTILOCK MO / BLUE	DRIVER'S UNDERSCUTTLE
FC5	THROUGH-PANEL (48 MICRO / 6) / BLACK	LH FASCIA END PANEL / OUTER AIR VENT
FC6	THROUGH-PANEL (48 MICRO / 6) / BLACK	RH FASCIA END PANEL / OUTER AIR VENT
FC7	THROUGH-PANEL (48 MICRO / 6) / BLACK	PASSENGER'S UNDERSCUTTLE
FC16	20-WAY MULTILOCK 040 / BLACK	PASSENGER'S UNDERSCUTTLE

GROUNDS

Ground	Location / Type
CAG30L	LH 'A' POST GROUND SCREW
CCG51L	CENTER CONSOLE GROUND STUD
CCG51R	CENTER CONSOLE GROUND STUD
CCG8L	CENTER CONSOLE GROUND STUD
FCG15R	LH CONSOLE GROUND STUD
FCG28R	LH CONSOLE GROUND STUD

CONTROL MODULE PIN OUT INFORMATION (FOLD OUT PAGE)



REFER TO THE FRONT OF THE BOOK FOR ILLUSTRATIONS DETAILING THE LOCATION AND IDENTIFICATION OF COMPONENTS, RELAYS, CONNECTORS, HARNESES, GROUNDS, VEHICLE CONTROL MODULES AND CONTROL MODULE PINS.

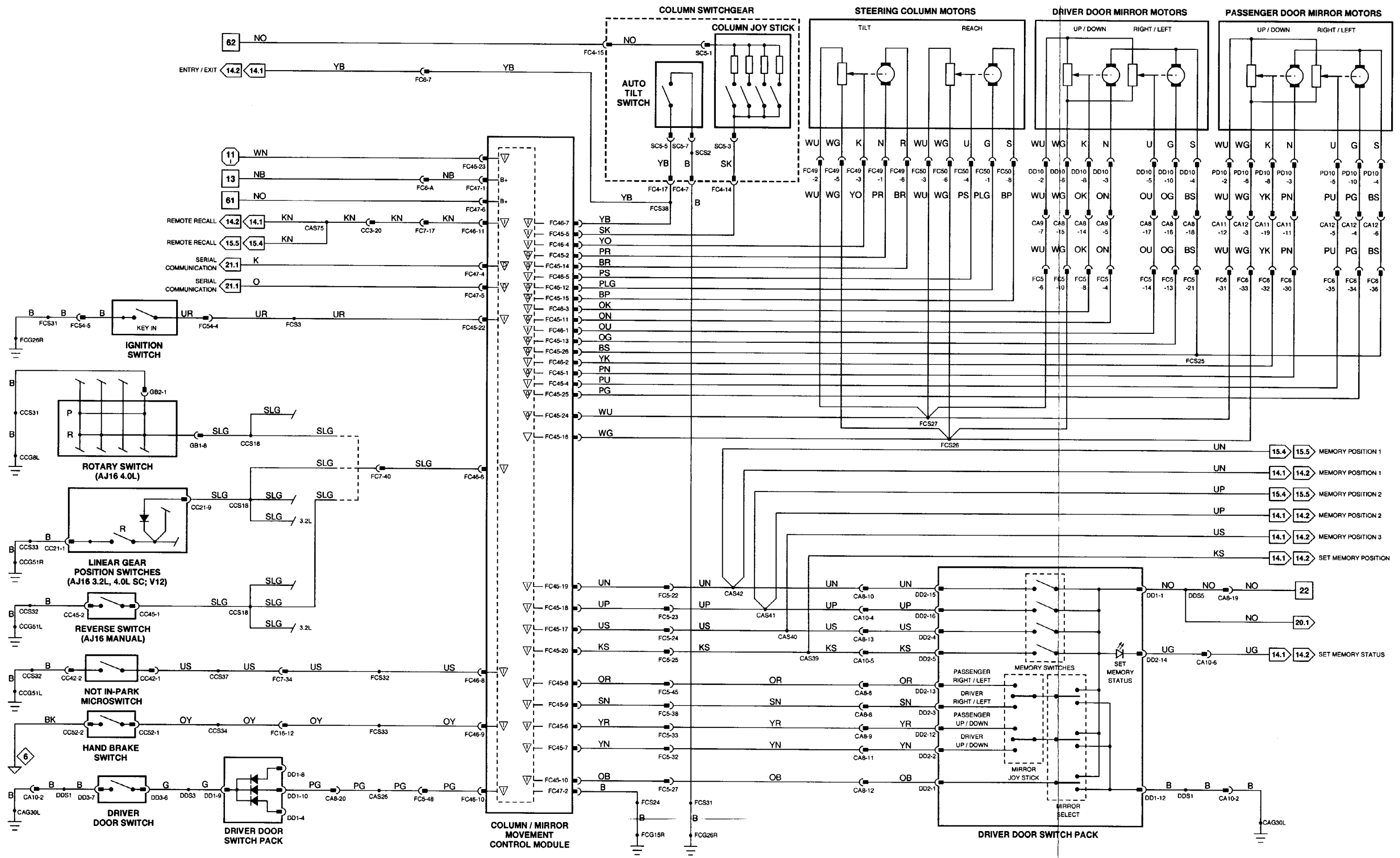

1 - 6 Fig. 01.1   
 7 - 65 Fig. 01.2   
 66 - 109 Fig. 01.3   
 I II Fig. 01.4   
 I II Fig. 02.1   
 ◇ Fig. 02.2   
 ▽ Input   
 ▽ Output   
 ▽ Serial and Encoded Communications   
 ▽ Signal Ground (SG)

VARIANT: LHD Memory Vehicles  
 VIN RANGE: All  
 DATE OF ISSUE: JANUARY 1995

## CONTROL MODULE PIN OUT INFORMATION

### COLUMN / MIRROR MOVEMENT CONTROL MODULE

Pin	Description	Active	Inactive
O FC45-1	PASSENGER MIRROR UP / DOWN MOTOR	B+ (UP)	GROUND
O FC45-2	STEERING COLUMN TILT MOTOR	B+ (UP)	GROUND
I FC45-4	PASSENGER MIRROR RIGHT / LEFT POTENTIOMETER FEEDBACK	0.5 V (LEFT), 4 V (RIGHT)	
I FC45-5	STEERING COLUMN MOVEMENT JOYSTICK	6.8 V (OUT), 8.5 V (IN) 10.1 V (UP), 12.1 V (DOWN)	GROUND GROUND
I FC45-6	PASSENGER MIRROR UP / W W N REQUEST	B+ (UP), GROUND (DOWN)	OPEN CIRCUIT
I FC45-7	DRIVER MIRROR UP / DOWN REQUEST	B+ (UP), GROUND (DOWN)	OPEN CIRCUIT
I FC45-8	PASSENGER MIRROR RIGHT / LEFT REQUEST	B+ (RIGHT), GROUND (LEFT)	OPEN CIRCUIT
I FC45-9	DRIVER MIRROR RIGHT / LEFT REQUEST	B+ (RIGHT), GROUND (LEFT)	OPEN CIRCUIT
I FC45-10	MIRROR SELECT	SAME AS DIRECTIONAL REQUEST IN USE	OPEN CIRCUIT
O FC45-11	DRIVER MIRROR UP / DOWN MOTOR	B+ (UP)	
O FC45-12	STEERING COLUMN REACH MOTOR	B+ (IN)	GROUND
O FC45-13	DRIVER MIRROR RIGHT / LEFT MOTOR	B+ (RIGHT)	GROUND
O FC45-14	STEERING COLUMN TILT MOTOR	B+ (DOWN)	GROUND
O FC45-15	STEERING COLUMN REACH MOTOR	B+ (OUT)	GROUND
SG FC45-16	COLUMN AND MIRROR POTENTIOMETER COMMON REFERENCE GROUND	GROUND	GROUND
I FC45-17	MEMORY 3 SWITCH REQUEST	B+	GROUND
I FC45-18	MEMORY 2 SWITCH REQUEST	B+	GROUND
I FC45-19	MEMORY 1 SWITCH REQUEST	B+	GROUND
I FC45-20	MEMORY SET SWITCH REQUEST	B+	GROUND
I FC45-22	KEY IN IGNITION SWITCH SIGNAL	GROUND	B+
I FC45-23	IGNITION SWITCHED GROUND	GROUND	B+
O FC45-24	COLUMN AND MIRROR POTENTIOMETER COMMON REFERENCE VOLTAGE	5 V	5 V
O FC45-25	PASSENGER MIRROR RIGHT / LEFT MOTOR	B+ (RIGHT)	GROUND
O FC45-26	DRIVER AND PASSENGER MIRROR MOTORS COMMON	B+ (LEFT), GROUND (RIGHT)	GROUND
I FC46-1	DRIVER MIRROR RIGHT / LEFT POTENTIOMETER FEEDBACK	0.5 V (LEFT), 4 V (RIGHT)	
I FC46-2	PASSENGER MIRROR UP / DOWN POTENTIOMETER FEEDBACK	0.5 V (DOWN), 4 V (UP)	
I FC46-3	DRIVER MIRROR UP / W W N POTENTIOMETER FEEDBACK	0.5 V (DOWN), 4 V (UP)	
I FC46-4	STEERING COLUMN TILT POTENTIOMETER FEEDBACK	0.5 V (DOWN), 4 V (UP)	
I FC46-5	STEERING COLUMN REACH POTENTIOMETER FEEDBACK	0.5 V (OUT), 4 V (IN)	
I FC46-6	IGNITION VOLTAGE	B+	GROUND
I FC46-7	AUTO / MANUAL TILT SELECTION SWITCH	GROUND = AUTO	B+ = OFF
I FC46-8	NOT IN PARK	GROUND	B+
I FC46-9	HANDBRAKE ON	GROUND	B+
I FC46-10	DRIVER DOOR AJAR	GROUND	7.9 V
I FC46-11	REMOTE SEAT / MIRROR COLUMN REQUEST	GROUND PULSE	B+
D FC47-4	SERIAL COMMUNICATION OUTPUT		
O FC47-5	SERIAL COMMUNICATION INPUT		

The following symbols are used to represent values for Control Module Pin Out data:

I	Input	B+	Battery voltage
O	Output	V	Voltage (DC)
SG	Signal Ground	Hz	Frequency
D	Serial and encoded communications	KHz	Frequency x 1000
		MS	Milliseconds
		MV	Millivolts

**CAUTION:** The information on this data page is furnished to aid the user in understanding circuit operation. THIS INFORMATION SHOULD BE USED FOR REFERENCE ONLY.

**NOTE:** The values listed are approximately those that can be expected at the control module connector pins with all circuit connections made and all components connected and fitted. "Active" means a load is applied or a switch is ON; "Inactive" means a load is not applied or a switch is OFF.

**Fig. 13.3**

## COMPONENTS

Component	Connector / Type / Color	Location / Access
AUTO TILT SWITCH (COLUMN SWITCHGEAR)	SC5 (FLY LEAD) / 8-WAY GROTE AND HARTMAN / BLACK	STEERING COLUMN / COVER
COLUMN MIRROR MOVEMENT CONTROL MODULE	FC45 / 26-WAY MULTILOCK 47 / SLATE FC46 / 16-WAY MULTILOCK 47 / SLATE FC47 / 12-WAY MULTILOCK 47 / SLATE	RH UNDERSCUTTLE
COLUMN JOYSTICK (COLUMN SWITCHGEAR)	SC5 (FLY LEAD) / 8-WAY GROTE AND HARTMAN / BLACK	STEERING COLUMN / COVER
W O R MIRROR MOTORS - DRIVER	DD10 (FLY LEAD) / 12-WAY MULTILOCK 040 / BLACK	MIRROR ASSEMBLY
DOOR MIRROR MOTORS - PASSENGER	PD10 (FLY LEAD) / 12-WAY MULTILOCK 040 / BLACK	MIRROR ASSEMBLY
DOOR SWITCH - DRIVER	DD3 (113-WAY ECONOSEAL) / 11 LC / BLACK	DOOR CASING
DOOR SWITCH PACK - DRIVER	DD1 (112-WAY MULTILOCK 47) / WHITE DD2 (122-WAY MULTILOCK 47) / WHITE	ARM REST / TOP RDLL
HAND BRAKE SWITCH	CC52 / 2-WAY MULTILOCK 040 / BLACK	CENTER CONSOLE, LH SIDE
IGNITION SWITCH	FC54 (FLY LEAD) / 10-WAY MULTILOCK 070 / WHITE	STEERING COLUMN / COVER
LINEAR GEAR POSITION SWITCHES	CC21 / 20-WAY MULTILOCK M 0 / BLACK	'J' GATE / CENTER CONSOLE
NOT IN-PARK MICROSWITCH	CC42 (FLY LEAD) / 12-WAY MULTILOCK M 0 / BLACK	'J' GATE / CENTER CONSOLE
REVERSE SWITCH (AJ16) MANUAL	CC45 / 2-WAY SUMITOMO / WHITE	TRANSMISSION TUNNEL / CENTER CONSOLE
ROTARY SWITCH	GB1 (FLY LEAD) / 8-WAY MULTILOCK 070 / WHITE GB2 (FLY LEAD) / 12-WAY MULTILOCK 040 / BLACK	'J' GATE / CENTER CONSOLE
STEERING COLUMN MOTORS	FC49 (FLY LEAD) / 8-WAY MULTILOCK 070 / WHITE FCM (FLY LEAD) / 8-WAY MULTILOCK 070 / YELLOW	STEERING COLUMN / DRIVERS UNDERSCUTTLE

## HARNESSTO-HARNESCONNECTORS

Connector	Type / Color	Location / Access
CA9	20-WAY MULTILOCK 040 / GREEN	DRIVERS UNDERSCUTTLE
CA9	20-WAY MULTILOCK M 0 / BLACK	DRIVERS 'A' POST / 'A' POST TRIM
CA10	8-WAY MULTILOCK 070 / WHITE	DRIVERS UNDERSCUTTLE
CA11	20-WAY MULTILOCK M 0 / BLACK	PASSENGERS UNDERSCUTTLE / ECM
CA12	12-WAY MULTILOCK 070 / WHITE	PASSENGERS UNDERSCUTTLE / ECM
CC3	20-WAY MULTILOCK M 0 / BLACK	CENTER CONSOLE / CENTER CONSOLE GLOVE BOX
FC4	20-WAY MULTILOCK M 0 / BLUE	DRIVERS UNDERSCUTTLE
FC5	THROUGH-PANEL (48 MICRO / 6) / BLACK	LH FASCIA END PANEL / OUTER AIR VENT
FC6	THROUGH-PANEL (48 MICRO / 6) / BLACK	RH FASCIA END PANEL / OUTER AIR VENT
FC7	THROUGH-PANEL (48 MICRO / 6) / BLACK	PASSENGERS UNDERSCUTTLE
FC16	20-WAY MULTILOCK M 0 / BLACK	PASSENGERS UNDERSCUTTLE

## GROUNDS

Ground	Location / Type
CAG33L	RH HEELBOARD GROUND SCREW
CCG51L	CENTER CONSOLE GROUND STUD
CCG51R	CENTER CONSOLE GROUND STUD
CCG8L	CENTER CONSOLE GROUND STUD
FCG15R	LH CONSOLE GROUND STUD
FCG26R	LH CONSOLE GROUND STUD

## CONTROL MODULE PIN OUT INFORMATION (FOLD OUT PAGE)



REFER TO THE FRONT OF THE BOOK FOR ILLUSTRATIONS DETAILING THE LOCATION AND IDENTIFICATION OF COMPONENTS, RELAYS, CONNECTORS, HARNESSES, GROUNDS, VEHICLE CONTROL MODULES AND CONTROL MODULE PINS.



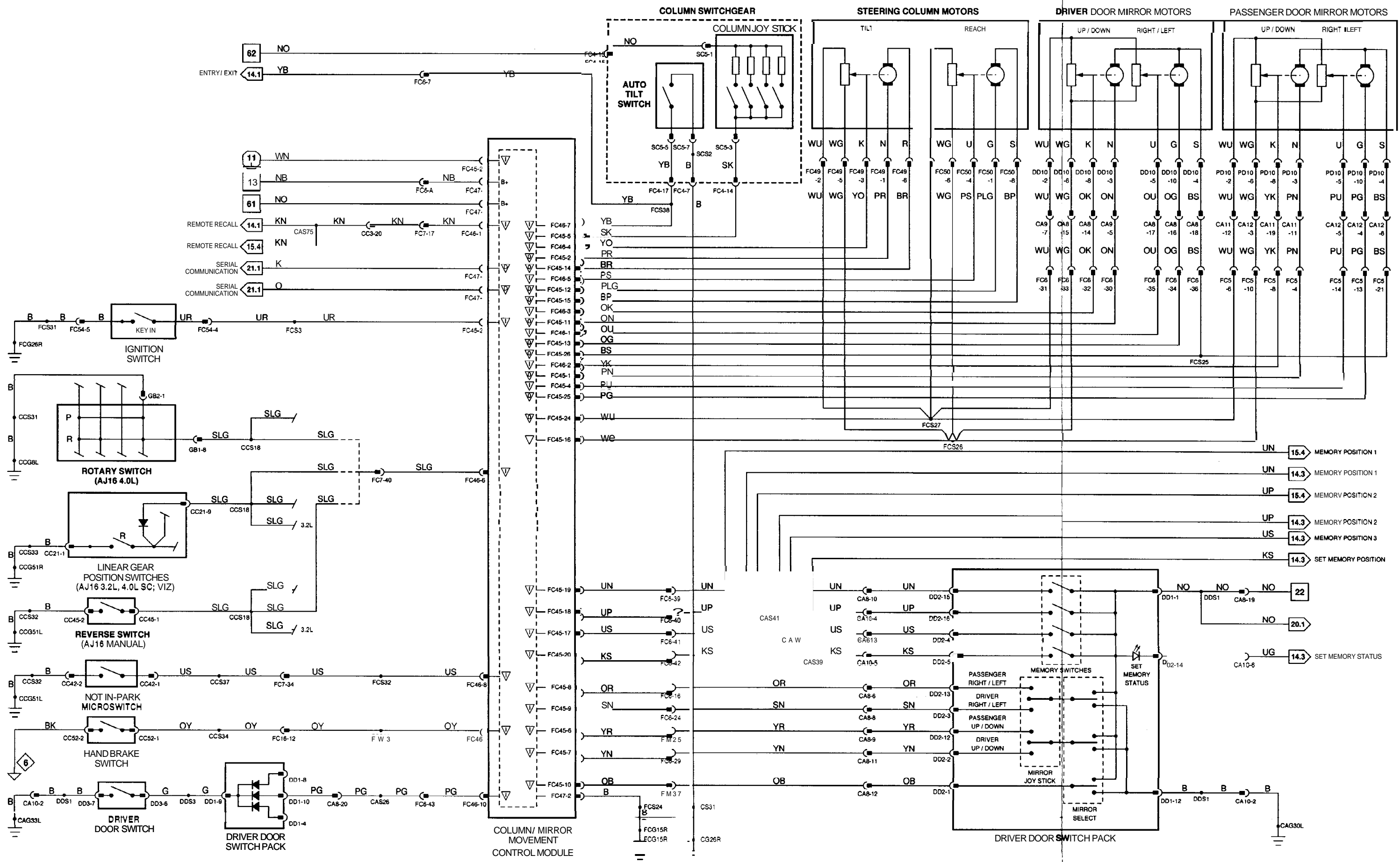

**Fig. 13.4****COMPONENTS****Component**

DOOR MIRROR MOTORS - DRIVER  
 DOOR MIRROR MOTORS - PASSENGER  
 W/O R SWITCH PACK - DRIVER

**Connector / Type / Color**

DD10 (FLY LEAD) / 112-WAY MULTILOCK 040 ■ BLACK  
 PD10 (FLY LEAD) / 12-WAY MULTILOCK 040 ■ BLACK  
 DD1 ■ 12-WAY MULTILOCK 41 ■ WHITE  
 DD2 / 22-WAY MULTILOCK 47 ■ WHITE

**Location / Access**

MIRROR ASSEMBLY  
 MIRROR ASSEMBLY  
 ARM REST/TOP ROLL

**HARNESS-TO-HARNESS CONNECTORS****Connector****Type / Color**

CA8 20-WAY MULTILOCK 040 / GREEN  
 CA9 20-WAY MULTILOCK 040 ■ BLACK  
 CA10 8-WAY MULTILOCK 070 / WHITE  
 CA11 20-WAY MULTILOCK 040 ■ BLACK  
 CA12 12-WAY MULTILOCK 070 ■ WHITE  
 FCS THROUGH-PANEL (48 MICRO / 6) ■ BLACK  
 FC6 THROUGH-PANEL (48 MICRO / 6) ■ BLACK

**Location / Access**

DRIVER'S UNDERSCUTTLE  
 DRIVERS 'A' POST / 'A' POST TRIM  
 DRIVER'S UNDERSCUTTLE  
 PASSENGER'S UNDERSCUTTLE / ECM  
 PASSENGER'S UNDERSCUTTLE / ECM  
 LH FASCIA END PANEL / OUTER AIR VENT  
 RH FASCIA END PANEL / OUTER AIR VENT

**GROUNDS****Ground****Location / Type**

CAG30L LH 'A' POST GROUND SCREW

REFER TO THE FRONT OF THE BOOK FOR ILLUSTRATIONS DETAILING THE LOCATION AND IDENTIFICATION OF COMPONENTS, RELAYS, CONNECTORS, HARNESES, GROUNDS, VEHICLE CONTROL MODULES AND CONTROL MODULE PINS.

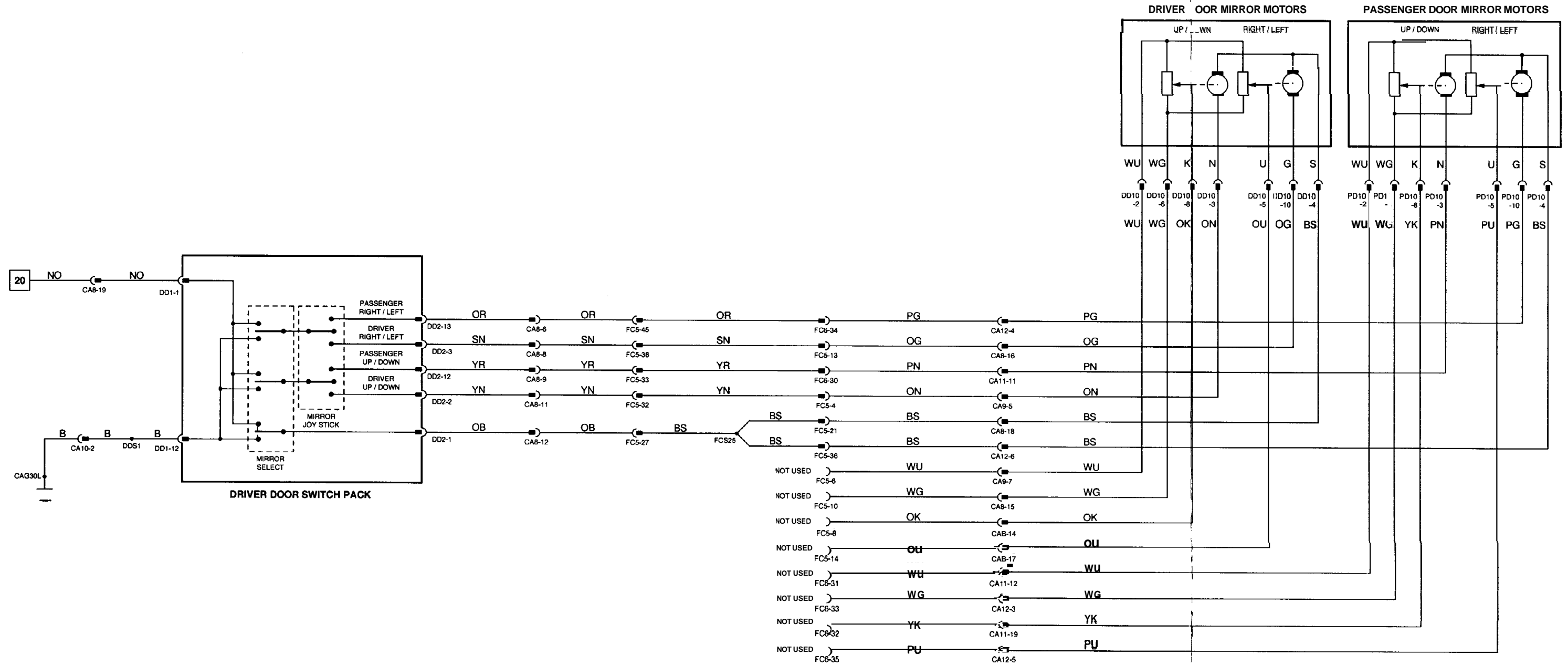

**Fig. 13.5****COMPONENTS****Component**

DOOR MIRROR MOTORS - DRIVER  
 DOOR MIRROR MOTORS - PASSENGER  
 W O R SWITCH PACK - DRIVER

**Connector / Type / Color**

DD10 (FLY LEAD) 12-WAY MULTILOCK WD BLACK  
 PD10 (FLY LEAD) 12-WAY MULTILOCK 040 / BLACK  
 DD1 / 12-WAY MULTILOCK 47 WHITE  
 DD2 / 22-WAY MULTILOCK 47 / WHITE

**Location / Access**

MIRROR ASSEMBLY  
 MIRROR ASSEMBLY  
 ARM REST / TOP ROLL

**HARNESS-TO-HARNESS CONNECTORS****Connector****Type / Color**

CA8 20-WAY MULTILOCK WD / GREEN  
 CA9 20-WAY MULTILOCK MO / BLACK  
 CA10 8-WAY MULTILOCK 070 / WHITE  
 CA11 20-WAY MULTILOCK MO BLACK  
 CA12 12-WAY MULTILOCK 070 / WHITE  
 FC5 THROUGH-PANEL (48 MICRO / 6) BLACK  
 FC6 THROUGH-PANEL (48 MICRO / 6) BLACK

**Location / Access**

DRIVER'S UNDERSCUTTLE  
 DRIVER'S 'A' POST / 'A' POST TRIM  
 DRIVER'S UNDERSCUTTLE  
 PASSENGER'S UNDERSCUTTLE IECM  
 PASSENGER'S UNDERSCUTTLE IECM  
 LH FASCIA END PANEL / OUTER AIR VENT  
 RH FASCIA END PANEL / OUTER AIR VENT

**GROUNDS****Ground****Location / Type**

CAG30L LH 'A' POST GROUND SCREW

REFER TO THE FRONT OF THE BOOK FOR ILLUSTRATIONS DETAILING THE LOCATION AND IDENTIFICATION OF COMPONENTS, RELAYS, CONNECTORS, HARNESSES, GROUNDS, VEHICLE CONTROL MODULES AND CONTROL MODULE PINS.

DATE OF ISSUE JANUARY 1995

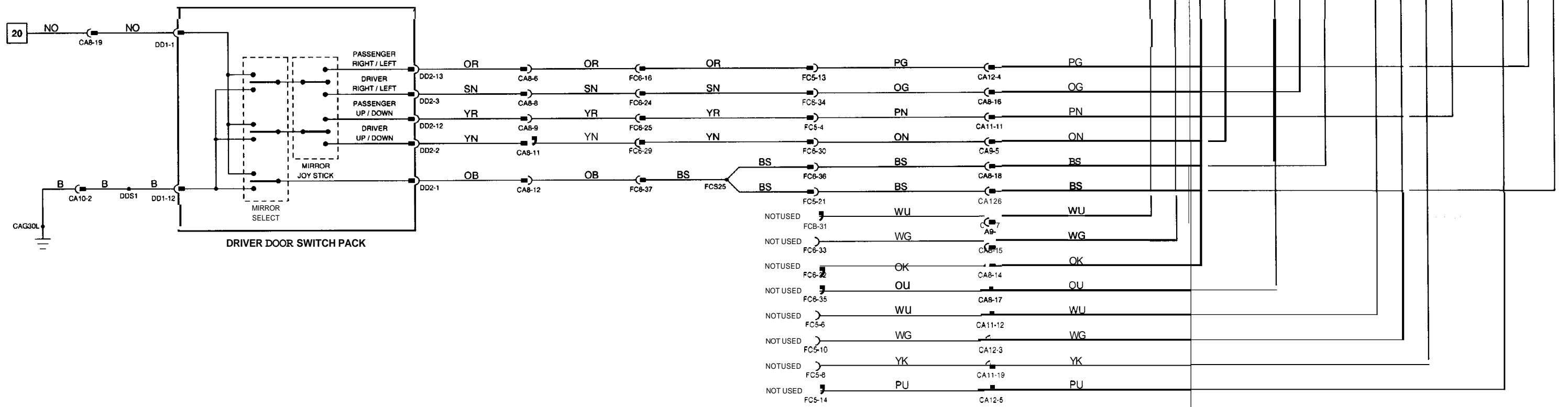

**Fig. 14.1**

**CONTROL MODULE PIN OUT INFORMATION**

**DRIVER SEAT CONTROL MODULE (ROW, MEMORY SEAT VEHICLES)**

Pin	Description	Active	Inactive
O PL1-2D	SEAT HEATER ON (STATE)	B+	GROUND
I PL1-3D	IGNITION SWITCHED GROUND	B+	GROUND
I PL1-4D	MEMORY POSITION 1 REQUEST	B+	GROUND
I PL1-5D	MEMORY POSITION 2 REQUEST	B+	GROUND
I PL1-6D	MEMORY POSITION 3 REQUEST	B+	GROUND
O PL1-8D	SET MEMORY STATUS (STATE)	GROUND	B+
I PL1-9D	ENTRY/EXIT SIGNAL	GROUND	B+
I PL1-10D	SEAT HEATER REQUEST	GROUND	B+
I PL1-12D	REMOTE RECALL REQUEST	GROUND PULSE ON UNLOCK	B+
I PL1-13D	NOT IN PARK	GROUND	B+
I PL1-14D	HANDBRAKE ON	GROUND	B+
I PL1-15D	KEY IN IGNITION	GROUND	B+
O PL1-16D	MEMORY SET	GROUND	B+
I PL1-18D	BRAKE SWITCH	GROUND	B+
I PL1-21D	SEAT MEMORY POSITION REQUEST	B+	GROUND
I PL1-22D	DRIVER'S W O R AJAR	GROUND	7.9 V
D PL2-1D	SERIAL COMMUNICATION INPUT		
O PL2-2D	SERIAL COMMUNICATION OUTPUT		
O SM1-1D	SQUAB RECLINE FORE / AFT MOTOR	B+ (AFT)	GROUND
O SM1-2D	SQUAB RECLINE FORE / AFT MOTOR	B+ (FORE)	GROUND
O SM1-3D	SEAT FRDNT RAISE / LOWER MOTOR	B+ (RAISE)	GROUND
O SM1-4D	SEAT FRONT RAISE / LOWER MOTOR	B+ (LOWER)	GROUND
O SM1-5D	SEAT REAR RAISE / LOWER MOTOR	B+ (RAISE)	GROUND
O SM1-6D	SEAT REAR RAISE / LOWER MOTOR	B+ (LOWER)	GROUND
O SM1-7D	SEAT FORE / AFT MOTOR	B+ (AFT)	GROUND
O SM1-8D	SEAT FORE / AFT MOTOR	B+ (FORE)	GROUND
O SM1-9D	COMMON GROUND	GROUND	GROUND
O SM1-10D	HEATER ELEMENT SUPPLY	B+	GROUND
O SM1-11D	HEADREST RAISE / LOWER MOTOR	B+ (RAISE)	GROUND
O SM1-12D	HEADREST RAISE / LOWER MOTOR	B+ (LOWER)	GROUND
O SM6-1D	POTENTIOMETER COMMON REFERENCE VOLTAGE	5 v	5 v
SG SM6-2D	POTENTIOMETER COMMON REFERENCE GROUND	GROUND	GROUND
O SM6-3D	HEADREST POTENTIOMETER FEEDBACK	0.5 V (DOWN), 4 V (UP)	
O SM6-4D	SQUAB RECLINE POTENTIOMETER FEEDBACK	0.5 V (BACK), 4 V (FORWARD)	
O SM6-5D	SEAT FORE AFT POTENTIOMETER FEEDBACK	0.5 V (BACK), 4 V (FORWARD)	
O SM6-6D	SEAT REAR RAISE / LOWER POTENTIOMETER FEEDBACK	0.5 V (LOWER), 4 V (RAISE)	
O SM6-7D	SEAT FRONT RAISE / LOWER POTENTIOMETER FEEDBACK	0.5 V (LOWER), 4 V (RAISE)	
I SM6-8D	RECLINE AFT MOVEMENT REQUEST	B+	GROUND
I SM6-9D	SEAT AFT MOVEMENT REQUEST	B+	GROUND
I SM6-10D	SEAT FORE MOVEMENT REQUEST	B+	GROUND
O SM6-11D	LUMBAR SWITCH POWER SUPPLY	B+	GROUND
I SM6-14D	HEADREST LOWER MOVEMENT REQUEST	B+	GROUND
I SM6-15D	HEADREST RAISE MOVEMENT REQUEST	B+	GROUND
I SM6-16D	SEAT REAR LOWER MOVEMENT REQUEST	B+	GROUND
I SM6-17D	SEAT REAR RAISE MOVEMENT REQUEST	B+	GROUND
I SM6-18D	SEAT FRONT LOWER MOVEMENT REQUEST	B+	GROUND
I SM6-19D	SEAT FRONT RAISE MOVEMENT REQUEST	B+	GROUND
I SM6-20D	RECLINE FORE MOVEMENT REQUEST	B+	GROUND

**BODY PROCESSOR MODULE**

Pin	Description	Active	Inactive
O FC1-23	DRIVER SEAT HEATER ON	GROUND	B+
I FC2-38	DRIVER SEAT HEATER REQUEST	GROUND	B+

The following symbols are used to represent values for Control Module Pin Out data:

<b>I</b> Input	<b>B+</b> Battery voltage
<b>O</b> Output	<b>V</b> Voltage (DC)
<b>SG</b> Signal Ground	<b>Hz</b> Frequency
<b>D</b> Serial and encoded communications	<b>KHz</b> Frequency x 1000
	<b>MS</b> Milliseconds
	<b>MV</b> Millivolts

**CAUTION:** The information on this data page is furnished to aid the user in understanding circuit operation. THIS INFORMATION SHOULD BE USED FOR REFERENCE ONLY.

**NOTE:** The values listed are approximately those that can be expected at the control module connector pins with all circuit connections made and all components connected and fitted. "Active" means a load is applied or a switch is ON; "Inactive" means a load is not applied or a switch is OFF.

**COMPONENTS**

Component	Connector / Type / Color	Location / Access
BODY PROCESSOR MODULE	FC1 / 48-WAY PCB SIGNAL / YELLOW FC2 / 48-WAY PCB SIGNAL / BLACK FC3 / 6-WAY PCB SIGNAL / BLACK	PASSENGER'S UNDERSCUTTLE
BRAKE SWITCH	CA72 / 14-WAY MULTILOCK 0701 / WHITE	DRIVER'S UNDERSCUTTLE
CENTER CONSOLE SWITCH PACK	CC1 / 16-WAY MULTILOCK 040 / BLACK	CENTER CONSOLE
DOOR SWITCH - DRIVER	DD3 / 13-WAY ECONOSEAL III LCI / BLACK	DOOR CASING
DOOR SWITCH PACK - DRIVER	DD1 / 72-WAY MULTILOCK 47 / WHITE DD2 / 22-WAY MULTILOCK 47 / WHITE	ARM REST / TOP ROLL
SEAT CONTROL MODULE - DRIVER (ROW, MEMORY SEAT VEHICLES)	PL1 / 22-WAY MULTILOCK 47 / BLUE B1P1-D2 / 22-WAY MULTILOCK 070 / BLUE / WHITE	DRIVER'S SEAT
SEAT CUSHION - DRIVER	SM6-D / 22-WAY MULTILOCK 471 / WHITE	
SEAT LUMBAR PUMP - DRIVER	SM7-D / 3-WAY MULTILOCK 070 / YELLOW	DRIVER'S SEAT / UNDER
SEAT MOTORS - DRIVER	SM10-D / 3-WAY MULTILOCK 070 / YELLOW SM2-D / 6-WAY MULTILOCK 0701 / WHITE SM3-D / 6-WAY MULTILOCK 070 / YELLOW SM4-D / 6-WAY MULTILOCK 070 / SLATE SM11-D / 6-WAY MULTILOCK 070 / WHITE SM13-D / 6-WAY MULTILOCK 070 / YELLOW	DRIVER'S SEAT / SQUAB DRIVER'S SEAT / UNDER DRIVER'S SEAT / UNDER DRIVER'S SEAT / UNDER DRIVER'S SEAT / UNDER
SEAT SWITCH PACK - DRIVER	SM5-D / 16-WAY MULTILOCK 0401 / BLACK	DRIVER'S SEAT
SQUAB - DRIVER	SM9-D / 3-WAY MULTILOCK 070 / SLATE	DRIVER'S SEAT
HAND BRAKE SWITCH	CC52 / 2-WAY MULTILOCK 040 / BLACK	CENTER CONSOLE, LH SIDE
IGNITION SWITCH	FC54 (FLY LEAD) / 18-WAY MULTILOCK 0701 / WHITE	STEERING COLUMN / COVER
NOT IN-PARK MICRO SWITCH	CC42 (FLY LEAD) / 12-WAY MULTILOCK 040 / BLACK	'J' GATE / CENTER CONSOLE

**HARNESSTO-HARNESCONNECTORS**

Connector	Type / Color	Location / Access
CA8	20-WAY MULTILOCK 040 / GREEN	DRIVER'S UNDERSCUTTLE
CA10	8-WAY MULTILOCK 070 / WHITE	DRIVER'S UNDERSCUTTLE
CA23	20-WAY MULTILOCK 040 / BLACK	DRIVER'S SEAT
CA24	6-WAY MULTILOCK 070 / WHITE	DRIVER'S SEAT
CC3	20-WAY MULTILOCK 040 / BLACK	CENTER CONSOLE / CENTER CONSOLE GLOVE BOX
CC4	14-WAY MULTILOCK 070 / WHITE	CENTER CONSOLE / CENTER CONSOLE GLOVE BOX
CC5	20-WAY MULTILOCK 070 / GREEN	CENTER CONSOLE / CENTER CONSOLE GLOVE BOX
FC5	THROUGH-PANEL 148 MICRO / 6 / BLACK	LH FASCIA END PANEL / OUTER AIR VENT
FC6	THROUGH-PANEL 148 MICRO / 6 / BLACK	RH FASCIA END PANEL / OUTER AIR VENT
FC7	THROUGH-PANEL 148 MICRO / 6 / BLACK	PASSENGER'S UNDERSCUTTLE

**GROUNDS**

Ground	Location / Type
CAG30L	LH 'A' POST GROUND SCREW
CAG30R	LH 'A' POST GROUND SCREW
CAG33L	RH HEELBOARD GROUND SCREW
CAG33R	RH HEELBOARD GROUND SCREW
CCG51L	CENTER CONSOLE GROUND STUD
FCG15L	LH CONSOLE GROUND STUD
FCG26R	LH CONSOLE GROUND STUD
PLG3L	LH SEAT GROUND SCREW
PLG3R	LH SEAT GROUND SCREW

**CONTROL MODULE PIN OUT INFORMATION (FOLD OUT PAGE)**



REFER TO THE FRONT OF THE BOOK FOR ILLUSTRATIONS DETAILING THE LOCATION AND IDENTIFICATION OF COMPONENTS, RELAYS, CONNECTORS, HARNESSES, GROUNDS, VEHICLE CONTROL MODULES AND CONTROL MODULE PINS.



NOTE REFER TO FIGURES 11.2 AND 11.3 FOR DRIVER SEAT BELT WARNINGS.

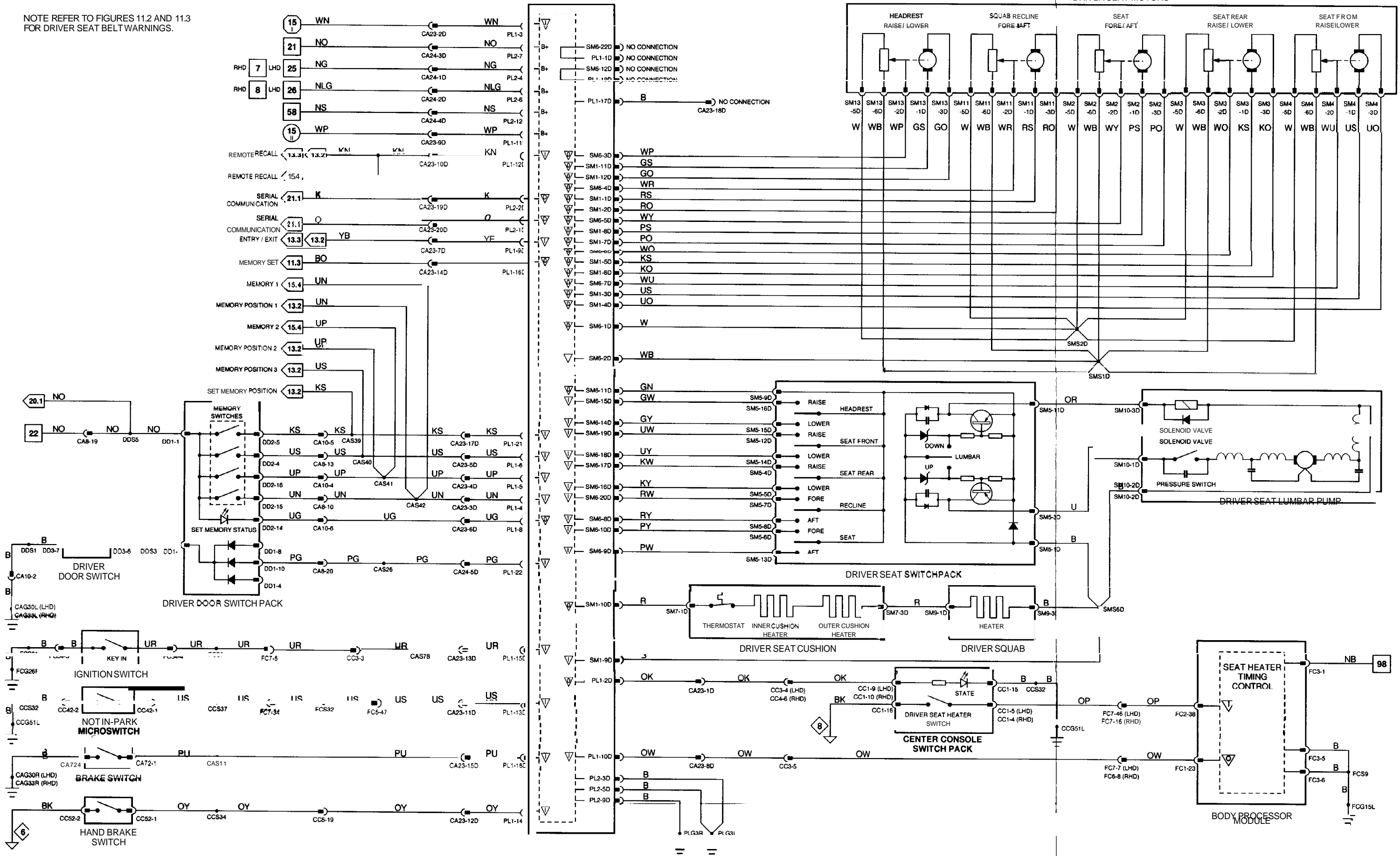

## CONTROL MODULE PIN OUT INFORMATION

### DRIVER SEAT CONTROL MODULE (NAS VEHICLES)

Pin	Description	Active	Inactive
O	CA105-2	SEAT HEATER ON LED	B+
I	CA105-3	IGNITION SWITCHED GROUND	GROUND
I	CA105-4	MEMORY POSITION 1 REQUEST	B+
I	CA105-5	MEMORY POSITION 2 REQUEST	B+
I	CA105-6	MEMORY POSITION 3 REQUEST	B+
O	CA105-8	SEAT MEMORY STATUS LED	GROUND
I	CA105-9	ENTRY / EXIT SIGNAL	GROUND
I	CA105-10	SEAT HEATER REQUEST	GROUND
I	CA105-12	REMOTE RECALL REQUEST	GROUND PULSE ON UNLOCK
I	CA105-13	NOT IN PARK SIGNAL	GROUND
I	CA105-14	PARK BRAKE ON SIGNAL	GROUND
I	CA105-15	KEY IN IGNITION SIGNAL	GROUND
O	CA105-16	MEMORY SET	GROUND
I	CA105-18	BRAKE SWITCH SIGNAL	GROUND
I	CA105-21	SET MEMORY POSITION REQUEST	B+
I	CA105-22	DRIVER DOOR AJAR	GROUND
D	CA106-1	SERIAL COMMUNICATION INPUT	
D	CA106-2	SERIAL COMMUNICATION OUTPUT	
O	SM1-1D	SQUAB RECLINE FORE / AFT MOTOR	B+ (AFT)
O	SM1-2D	SQUAB RECLINE FORE / AFT MOTOR	B+ (FORE)
O	SM1-3D	SEAT FRONT RAISE LOWER MOTOR	B+ (UPI)
O	SM1-4D	SEAT FRONT RAISE LOWER MOTOR	B+ (DOWN)
O	SM1-5D	SEAT REAR RAISE LOWER MOTOR	B+ (UPI)
O	SM1-6D	SEAT REAR RAISE LOWER MOTOR	B+ (DOWN)
O	SM1-7D	SEAT FORE AFT MOTOR	B+ (AFT)
O	SM1-8D	SEAT FORE AFT MOTOR	B+ (FORE)
O	SM1-9D	COMMON GROUND	GROUND
O	SM1-10D	HEATER ELEMENT SUPPLY	B+
O	SM1-11D	HEADREST RAISE LOWER MOTOR	B+ (RAISE)
O	SM1-12D	HEADREST RAISE / LOWER MOTOR	B+ (LOWER)
O	SM6-1D	POTENTIOMETER COMMON REFERENCE VOLTAGE	5 v
SG	SM6-2D	POTENTIOMETER COMMON REFERENCE GROUND	GROUND
O	SM6-3D	HEADREST FEEDBACK VOLTAGE	0.5 V (DOWN), 4 V (UP)
O	SM6-4D	SQUAB RECLINE FEEDBACK VOLTAGE	0.5 V (BACK), 4 V (FORWARD)
O	SM6-5D	SEAT FORE AFT FEEDBACK VOLTAGE	0.5 V (AFT), 4 V (FORE)
O	SM6-6D	SEAT REAR RAISE / LOWER FEEDBACK VOLTAGE	0.5 V (DOWN), 4 V (UP)
O	SM6-7D	SEAT FRONT RAISE LOWER FEEDBACK VOLTAGE	0.5 V (DOWN), 4 V (UP)
I	SM6-8D	RECLINE AFT MOVEMENT REQUEST	B+
I	SM6-9D	SEAT AFT MOVEMENT REQUEST	B+
I	SM6-10D	SEAT FORE MOVEMENT REQUEST	B+
O	SM6-11D	LUMBAR SWITCH POWER SUPPLY	B+
I	SM6-14D	HEADREST LOWER MOVEMENT REQUEST	B+
I	SM6-15D	HEADREST RAISE MOVEMENT REQUEST	B+
I	SM6-16D	SEAT REAR LOWER MOVEMENT REQUEST	B+
I	SM6-17D	SEAT REAR RAISE MOVEMENT REQUEST	B+
I	SM6-18D	SEAT FRONT LOWER MOVEMENT REQUEST	B+
I	SM6-19D	SEAT FRONT RAISE MOVEMENT REQUEST	B+
I	SM6-20D	RECLINE FORE MOVEMENT REQUEST	B+

### BODY PROCESSOR MODULE

Pin	Description	Active	Inactive
O	FC1-23	DRIVER SEAT HEATER ON	GROUND
I	FC2-38	DRIVER SEAT HEATER REQUEST	B+

The following symbols are used to represent values for Control Module Pin Out data:

I	Input	B+	Battery voltage
O	Output	V	Voltage (DC)
SG	Signal Ground	Hz	Frequency
D	Serial and encoded communications	KHz	Frequency x 1000
		MS	Milliseconds
		MV	Millivolts

**CAUTION:** The information on this data page is furnished to aid the user in understanding circuit operation. THIS INFORMATION SHOULD BE USED FOR REFERENCE ONLY.

**NOTE:** The values listed are approximately those that can be expected at the control module connector pins with all circuit connections made and all components connected and fitted. "Active" means a load is applied or a switch is ON; "Inactive" means a load is not applied or a switch is OFF.

## Fig. 14.2

### COMPONENTS

Component	Connector / Type / Color	Location / Access
BODY PROCESSOR MODULE	FC1 / 48-WAY PCB SIGNAL / YELLOW FC2 / 48-WAY PCB SIGNAL / BLACK FC3 / 16-WAY PCB SIGNAL / BLACK	PASSENGER'S UNDERSCUTTLE
BRAKE SWITCH	CA72 / 4-WAY MULTILOCK 070 / WHITE	DRIVER'S UNDERSCUTTLE
CENTER CONSOLE SWITCH PACK	CC1 / 16-WAY MULTILOCK 0401 / BLACK	CENTER CONSOLE
DOOR SWITCH - DRIVER	DD3 / 13-WAY ECONOSEAL III LC / BLACK	DOOR CASING
DOOR SWITCH PACK - DRIVER	DD1 / 12-WAY MULTILOCK 47 / WHITE DD2 / 12-WAY MULTILOCK 41 / WHITE	ARM REST / TOP ROLL
SEAT CONTROL MODULE - DRIVER (NAS VEHICLES)	CA105 / 22-WAY MULTILOCK 47 / BLUE CA106 / 12-WAY MULTILOCK 47 / BLUE SM1-D / 12-WAY MULTILOCK 47 / WHITE SM6-D / 12-WAY MULTILOCK 41 / WHITE	DRIVER'S SEAT
SEAT CUSHION - DRIVER	SM7-D / 3-WAY MULTILOCK 0701 / YELLOW	DRIVER'S SEAT / UNDER
SEAT LUMBAR PUMP - DRIVER	SM10-D / 3-WAY MULTILOCK 070 / YELLOW	DRIVER'S SEAT / SQUAB
SEAT MOTORS - DRIVER	SM2-D / 6-WAY MULTILOCK 0101 / WHITE SM3-D / 6-WAY MULTILOCK 070 / YELLOW SM4-D / 6-WAY MULTILOCK 0701 / SLATE SM11-D / 6-WAY MULTILOCK 070 / WHITE SM13-D / 18-WAY MULTILOCK 070 / YELLOW	DRIVER'S SEAT / UNDER DRIVER'S SEAT / UNDER DRIVER'S SEAT / UNDER DRIVER'S SEAT / UNDER
SEAT SWITCH PACK - DRIVER	SM5-D / 16-WAY MULTILOCK 040 / BLACK	DRIVER'S SEAT
SQUAB - DRIVER	SM9-D / 3-WAY MULTILOCK 0701 / SLATE	
HAND BRAKE SWITCH	CC52 / 2-WAY MULTILOCK 040 / SLACK	CENTER CONSOLE, LH SIDE
IGNITION SWITCH	FC54 (FLY LEAD) / 8-WAY MULTILOCK 070 / WHITE	STEERING COLUMN COVER
NOT IN-PARK MICROSWITCH	CC42 (FLY LEAD) / 2-WAY MULTILOCK 040 / BLACK	'J' GATE / CENTER CONSOLE

### HARNESS-TO-HARNESS CONNECTORS

Connector	Type / Color	Location / Access
CA8	20-WAY MULTILOCK 040 / GREEN	DRIVER'S UNDERSCUTTLE
CA10	8-WAY MULTILOCK 070 / WHITE	DRIVER'S UNDERSCUTTLE
CC3	20-WAY MULTILOCK 040 / BLACK	CENTER CONSOLE / CENTER CONSOLE GLOVE BOX
CC5	20-WAY MULTILOCK 040 / GREEN	CENTER CONSOLE / CENTER CONSOLE GLOVE BOX
FC5	THROUGH-PANEL (48 MICRO / 6) / BLACK	LH FASCIA END PANEL / OUTER AIR VENT
FC7	THROUGH-PANEL (48 MICRO / 6) / BLACK	PASSENGER'S UNDERSCUTTLE

### GROUNDS

Ground	Location / Type
CAG30L	LH 'A' POST GROUND SCREW
CAG30R	LH 'A' POST GROUND SCREW
CAG103L	LH SEAT GROUND STUD
CAG103R	LH SEAT GROUND STUD
CCG51L	CENTER CONSOLE GROUND STUD
FCG15L	LH CONSOLE GROUND STUD
FCG26R	LH CONSOLE GROUND STUD

### CONTROL MODULE PIN OUT INFORMATION (FOLD OUT PAGE)



REFER TO THE FRONT OF THE BOOK FOR ILLUSTRATIONS DETAILING THE LOCATION AND IDENTIFICATION OF COMPONENTS, RELAYS, CONNECTORS, HARNESSSES, GROUNDS, VEHICLE CONTROL MODULES AND CONTROL MODULE PINS.





NOTE REFER TO FIGURES 11.2AND11.3 FOR DRIVER SEAT BELT WARNINGS.

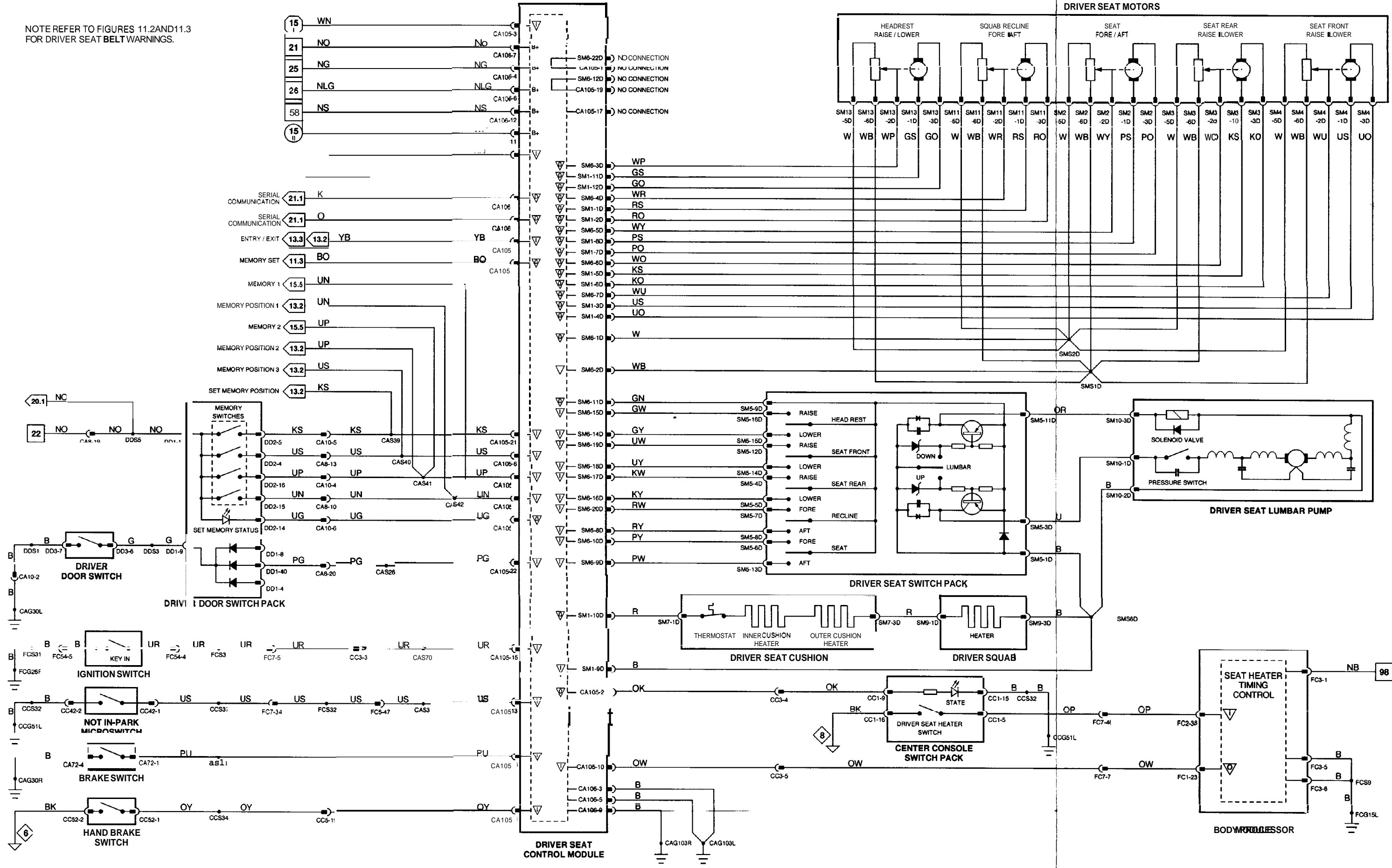

## CONTROL MODULE PIN OUT INFORMATION

### DRIVER SEAT CONTROL MODULE (ROW, MEMORY SEAT VEHICLES)

Pin	Description	Active	Inactive
O PL1-2D	SEAT HEATER ON (STATE)	B+	GROUND
I PL1-3D	IGNITION SWITCHED GROUND	GROUND	B+
I PL1-10D	SEAT HEATER REQUEST	GROUND	B+
I PL1-13D	NOT IN PARK	GROUND	B+
I PL1-14D	HANDBRAKE ON	GROUND	B+
I PL1-15D	KEY IN IGNITION	GROUND	B+
I PL1-18D	BRAKE SWITCH	GROUND	B+
I PL1-22D	DRIVER'S DOOR AJAR	GROUND	7.9 V
D PL2-1D	SERIAL COMMUNICATION INPUT		
D PL2-2D	SERIAL COMMUNICATION OUTPUT		
O SM1-1D	SOUAB RECLINE FORE AFT MOTOR	B+ (AFT)	GROUND
O SM1-2D	SOUAB RECLINE FORE AFT MOTOR	B+ (FORE)	GROUND
O SM1-3D	SEAT FRONT RAISE LOWER MOTOR	B+ (RAISE)	GROUND
O SM1-4D	SEAT FRONT RAISE LOWER MOTOR	B+ (LOWER)	GROUND
O SM1-5D	SEAT REAR RAISE LOWER MOTOR	B+ (RAISE)	GROUND
O SM1-6D	SEAT REAR RAISE LOWER MOTOR	B+ (LOWER)	GROUND
O SM1-7D	SEAT FORE AFT MOTOR	B+ (AFT)	GROUND
O SM1-8D	SEAT FORE AFT MOTOR	B+ (FORE)	GROUND
I SM1-9D	COMMON GROUND	GROUND	GROUND
O SM1-10D	HEATER ELEMENT SUPPLY	B+	GROUND
O SM1-11D	HEADREST RAISE LOWER MOTOR	B+ (RAISE)	GROUND
O SM1-12D	HEADREST RAISE LOWER MOTOR	B+ (LOWER)	GROUND
I SM6-8D	RECLINE AFT MOVEMENT REQUEST	B+	GROUND
I SM6-9D	SEAT AFT MOVEMENT REQUEST	B+	GROUND
I SM6-10D	SEAT FORE MOVEMENT REQUEST	B+	GROUND
O SM6-11D	LUMBAR SWITCH POWER SUPPLY	B+	GROUND
I SM6-14D	HEADREST LOWER MOVEMENT REQUEST	B+	GROUND
I SM6-15D	HEADREST RAISE MOVEMENT REQUEST	B+	GROUND
I SM6-16D	SEAT REAR LOWER MOVEMENT REQUEST	B+	GROUND
I SM6-17D	SEAT REAR RAISE MOVEMENT REQUEST	B+	GROUND
I SM6-18D	SEAT FRONT LOWER MOVEMENT REQUEST	B+	GROUND
I SMB-19D	SEAT FRONT RAISE MOVEMENT REQUEST	B+	GROUND
I SM6-20D	RECLINE FORE MOVEMENT REQUEST	B+	GROUND

### BODY PROCESSOR MODULE

Pin	Description	Active	Inactive
O FC1-23	DRIVER SEAT HEATER ON	GROUND	B+
I FC2-38	DRIVER SEAT HEATER REQUEST	GROUND	B+

The following symbols are used to represent values for Control Module Pin Out data:

I	Input	B+	Battery voltage
O	Output	V	Voltage (DC)
SG	Signal Ground	Hz	Frequency
D	Serial and encoded communications	KHz	Frequency x 1000
		MS	Milliseconds
		MV	Millivolts

## Fig. 14.3

### COMPONENTS

Component	Connector / Type / Color	Location / Access
BODY PROCESSOR MODULE	FC1 / 48-WAY PCB SIGNAL / YELLOW FC2 / 48-WAY PCB SIGNAL / BLACK F U / EWAY PCB SIGNAL / BLACK	PASSENGER'S UNDERSCUTTLE
BRAKE SWITCH	CA72 / 4-WAY MULTILOCK 070 / WHITE	DRIVER'S UNDERSCUTTLE
CENTER CONSOLE SWITCH PACK	CC1 / 16-WAY MULTILOCK 040 / BLACK	CENTER CONSOLE
DOOR SWITCH - DRIVER	DD3 / 113-WAY ECONOSEAL III LC / BLACK	DOOR CASING
W O R SWITCH PICK - DRIVER	DD1 / 12-WAY MULTILOCK 47 / WHITE DD2 / 122-WAY MULTILOCK 47 / WHITE	ARM REST / TOP ROLL
SEAT CONTROL MODULE - DRIVER (ROW, MEMORY SEAT VEHICLES)	PL1 / 22-WAY MULTILOCK 47 / BLUE PL2 / 12-WAY MULTILOCK 47 / BLUE SM1-D / 12-WAY MULTILOCK 47 / WHITE SM6-D / 22-WAY MULTILOCK 47 / WHITE	DRIVER'S SEAT
SEAT CUSHION - DRIVER	SM7-D / 3-WAY MULTILOCK 070 / YELLOW	DRIVER'S SEAT / UNDER
SEAT LUMBAR PUMP - DRIVER	SM10-D / 3-WAY MULTILOCK 070 / YELLOW	DRIVER'S SEAT / SOUAB
SEAT MOTORS - DRIVER	SM2-D / 6-WAY MULTILOCK 070 / WHITE SM3-D / 6-WAY MULTILOCK 070 / YELLOW SM4-D / 6-WAY MULTILOCK 070 / SLATE SM11-D / 6-WAY MULTILOCK 070 / WHITE SM13-D / 6-WAY MULTILOCK 070 / YELLOW	DRIVER'S SEAT / UNDER DRIVER'S SEAT / SOUAB DRIVER'S SEAT / UNDER DRIVER'S SEAT
SEAT SWITCH PACK - DRIVER	SM5 0116 WAY MULTILOCK 040 / BLACK	DRIVER'S SEAT
SOUAB - DRIVER	SM9-D / 3-WAY MULTILOCK 070 / SLATE	DRIVER'S SEAT
HAND BRAKE SWITCH	CC62 / 2-WAY MULTILOCK WD / BLACK	CENTER CONSOLE, LH SIDE
IGNITION SWITCH	FC54 (FLY LEAD) / 8-WAY MULTILOCK 070 / WHITE	STEERING COLUMN / COVER
NOT IN-PARK MICROSWITCH	CC42 (FLY LEAD) / 2-WAY MULTILOCK MO / BLACK	'J' GATE / CENTER CONSOLE

### HARNESS-TO-HARNESS CONNECTORS

Connector	Type / Color	Location / Access
CA6	20-WAY MULTILOCK 040 / GREEN	DRIVER'S UNDERSCUTTLE
CA10	8-WAY MULTILOCK 070 / WHITE	DRIVER'S UNDERSCUTTLE
CA23	20-WAY MULTILOCK 040 / BLACK	DRIVER'S SEAT
CA24	6-WAY MULTILOCK 070 / WHITE	DRIVER'S SEAT
CC3	20-WAY MULTILOCK 040 / BLACK	CENTER CONSOLE / CENTER CONSOLE GLOVE BOX
CC4	14-WAY MULTILOCK 070 / WHITE	CENTER CONSOLE / CENTER CONSOLE GLOVE BOX
CC5	20-WAY MULTILOCK 040 / GREEN	CENTER CONSOLE / CENTER CONSOLE GLOVE BOX
FC5	THROUGH-PANEL (48 MICRO / 6) / BLACK	LH FASCIA END PANEL / OUTER AIR VENT
FC6	THROUGH-PANEL (48 MICRO / 6) / BLACK	RH FASCIA END PANEL / OUTER AIR VENT
FC7	THROUGH-PANEL (48 MICRO / 6) / BLACK	PASSENGER'S UNDERSCUTTLE

### GROUNDS

Ground	Location / Type
CAG30L	LH 'A' POST GROUND SCREW
CAG30R	LH 'A' POST GROUND SCREW
CAGUL	RH HEELBOARD GROUND SCREW
CAG33R	RH HEELBOARD GROUND SCREW
CCG51L	CENTER CONSOLE GROUND STUD
FCG15L	LH CONSOLE GROUND STUD
FCG26R	LH CONSOLE GROUND STUD
PLG3L	LH SEAT GROUND SCREW
PLG3R	LH SEAT GROUND SCREW

### CONTROL MODULE PIN OUT INFORMATION (FOLD OUT PAGE)





NOTE REFER TO FIGURES 11.2 AND 11.3 FOR DRIVER SEAT BELT WARNINGS.

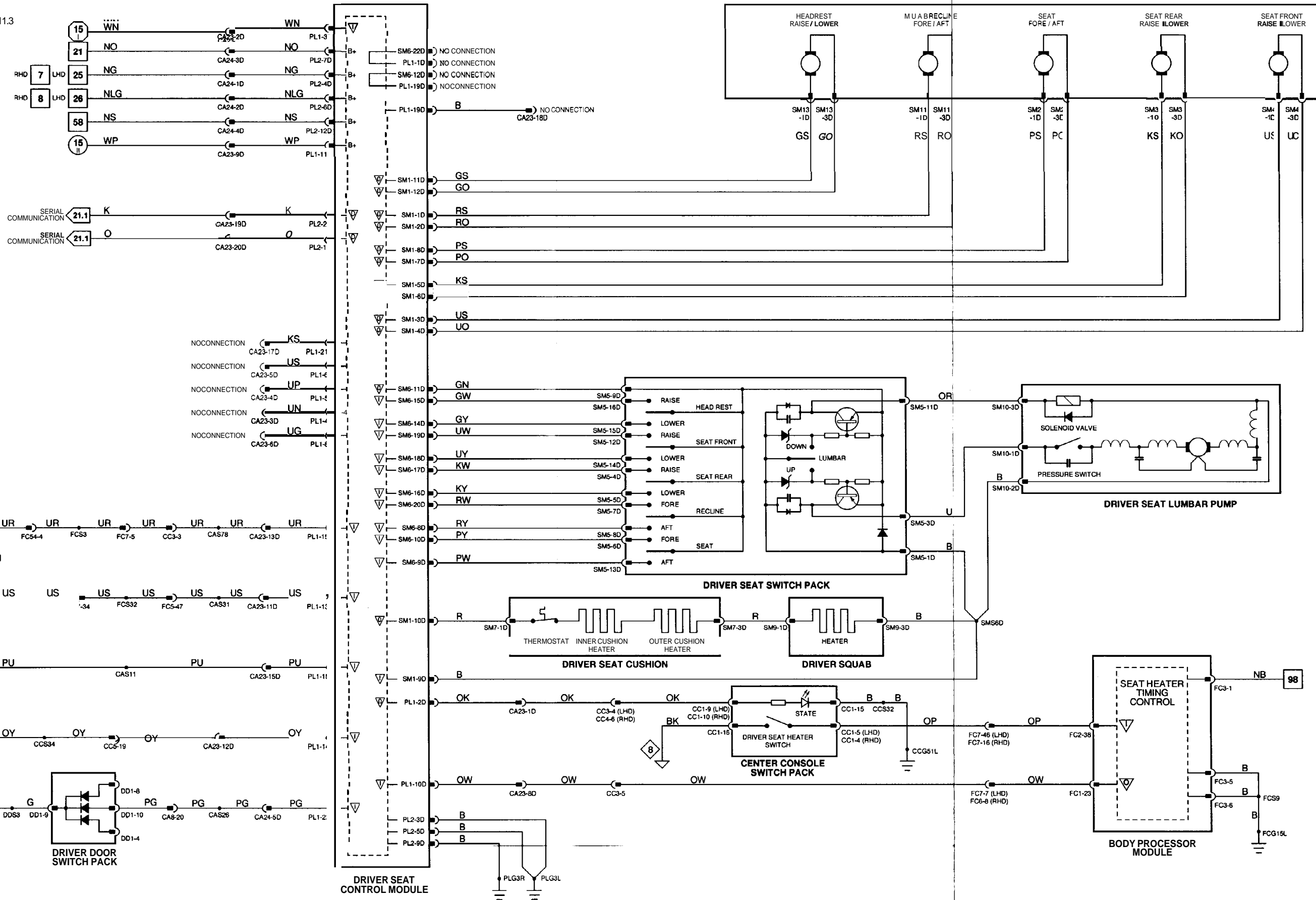

CONTROL MODULE PIN OUT INFORMATION

BODY PROCESSOR MODULE

Pin	Description	Active	Inactive
O FC1-23	DRIVER SEAT HEATER ON	GROUND	B+
I FC2-38	DRIVER SEAT HEATER REQUEST	GROUND	B+

**Fig. 14.4**

COMPONENTS

Component	Connector ■Type ■Color	Location ■Access
BODY PROCESSOR MODULE	FC1 / 48-WAY PCB SIGNAL / YELLOW FC2 / 48-WAY PCB SIGNAL / BLACK FC3 / 6-WAY PCB SIGNAL / BLACK	PASSENGER'S UNDERSCUTTLE
CENTER CONSOLE SWITCH PACK	CC1 / IS-WAY MULTILOCK 040 / BLACK	CENTER CONSOLE
SEAT CUSHION - DRIVER	SM7-D / 3-WAY MULTILOCK 070 / YELLOW	DRIVER'S SEAT / UNDER
SEAT MOTOR - DRIVER (RAISE / LOWER SEAT VEHICLES)	SM16-D / 6-WAY MULTILOCK 070 / SLATE	DRIVER'S SEAT / UNDER
SEAT SWITCH PACK - DRIVER (RAISE / LOWER SEAT VEHICLES)	SM17-D / 16-WAY MULTILOCK 040 / BLACK	DRIVERS SEAT
SQUAB - DRIVER	SM9-D / 3-WAY MULTILOCK 070 / SLATE	DRIVERS SEAT

RELAYS

Relay	Color ■Stripe	Connector ■Color	Location / Access
SEAT HEATER RELAY - DRIVER	BLACK	SM18-D / BLUE	DRIVER'S SEAT
SEAT LOWER RELAY - DRIVER	BLACK / VIOLET	SM14-D / BLUE	DRIVER'S SEAT
SEAT RAISE RELAY - DRIVER	BLACK / VIOLET	SM14-D / BLUE	DRIVERS SEAT

HARNESS-TO-HARNESS CONNECTORS

Connector	Type / Color	Location / Access
CA23-D	20-WAY MULTILOCK MO ■BLACK	DRIVER'S SEAT
CAZCD	6-WAY MULTILOCK 070 / WHITE	DRIVERS SEAT
CC3	20-WAY MULTILOCK 040 ■BLACK	CENTER CONSOLE / CENTER CONSOLE GLOVE BOX
CC4	14-WAY MULTILOCK 070 ■WHITE	CENTER CONSOLE / CENTER CONSOLE GLOVE BOX
FC6	THROUGH-PANEL (48 MICRO / 6) / BLACK	RH FASCIA END PANEL / OUTER AIR VENT
FC7	THROUGH-PANEL 148 MICRO / 6) / BLACK	PASSENGER'S UNDERSCUTTLE
ML1-D	10-WAY MULTILOCK 070 / WHITE	DRIVER'S SEAT / UNDER

GROUNDS

Ground	Location ■Type
CCG51L	CENTER CONSOLE GROUND STUD
FCG15L	LH CONSOLE GROUND STUD
MLGZL	LH SEAT GROUND SCREW
MLGZR	LH SEAT GROUND SCREW

CONTROL MODULE PIN OUT INFORMATION (FOLD OUT PAGE)



The following symbols are used to represent values for Control Module Pin Out data:

<b>I</b> Input	<b>B+</b> Battery voltage
<b>O</b> Output	<b>V</b> Voltage (DC)
<b>SG</b> Signal Ground	<b>Hz</b> Frequency
<b>D</b> Serial and encoded communications	<b>KHz</b> Frequency x 1000
	<b>MS</b> Milliseconds
	<b>MV</b> Millivolts

CAUTION: The information on this data page is furnished to aid the user in understanding circuit operation. THIS INFORMATION SHOULD BE USED FOR REFERENCE ONLY.

NOTE: The values listed are approximately those that can be expected at the control module connector pins with all circuit connections made and all components connected and fitted. "Active" means a load is applied or a switch is ON; "Inactive" means a load is not applied or a switch is OFF.

REFER TO THE FRONT OF THE BOOK FOR ILLUSTRATIONS DETAILING THE LOCATION AND IDENTIFICATION OF COMPONENTS, RELAYS, CONNECTORS, HARNESSES, GROUNDS, VEHICLE CONTROL MODULES AND CONTROL MODULE PINS.

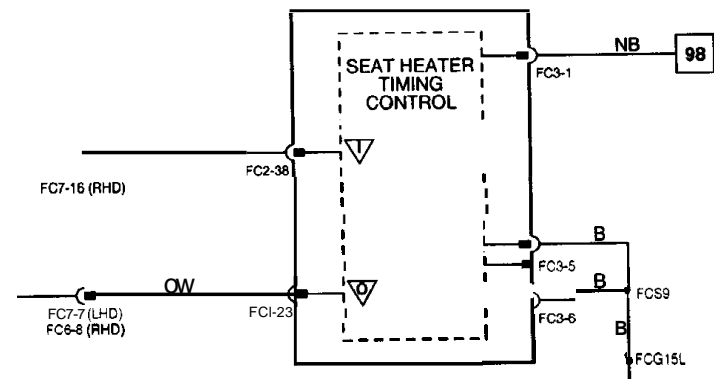
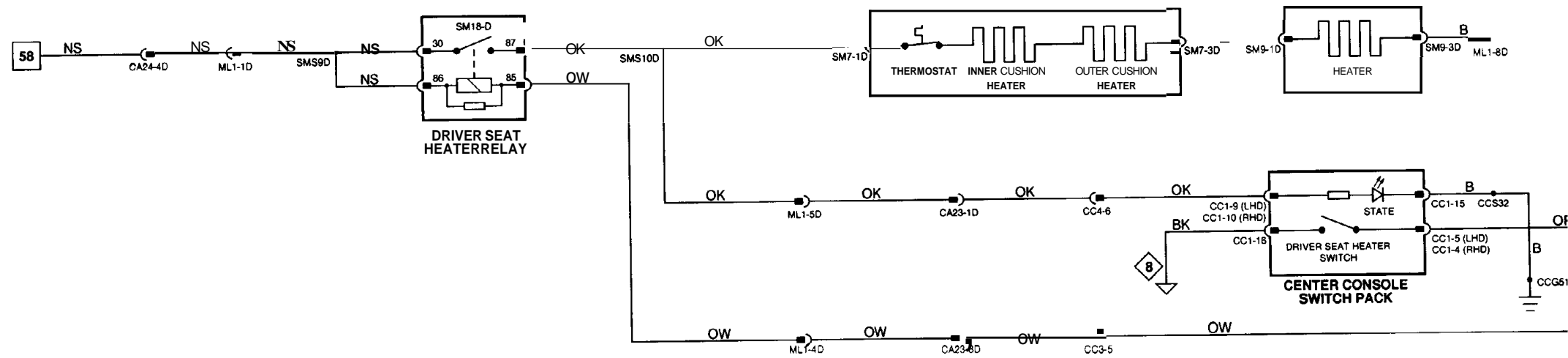
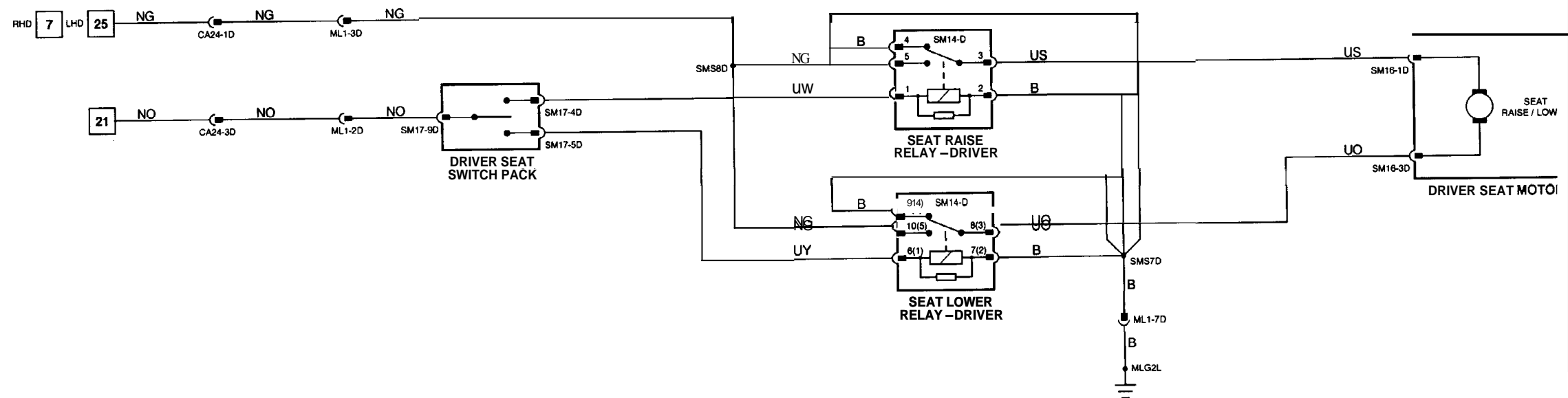

**CONTROL MODULE PIN OUT INFORMATION**

**PASSENGER SEAT CONTROL MODULE (ROW, MEMORY SEAT VEHICLES)**

Pin	Description	Active	Inactive
O PL1-2P	SEATHEATERONSTATE	B+	GROUND
I PL1-3P	IGNITION SWITCHEDPOWER	GROUND	B+
I PL1-4P	MEMORY POSITION 1 REQUEST	B+	GROUND
I PL1-5P	MEMDRY POSITION 2 REQUEST	B+	GROUND
I PL1-6P	MEMORY POSITION 3 REQUEST	B+	GROUND
O PL1-8P	SEAT MEMORY STATUS STATE	GROUND	B+
I PL1-10P	SEATHEATERREQUEST	GROUND	B+
I PL1-15P	KEY IN IGNITION SIGNAL	GROUND	B+
O PL1-16P	MEMORY SET AUDIBLE TDNE	GROUND	B+
I PL1-21P	SET MEMORY POSITION REQUEST	B+	GROUND
I PL1-22P	PASSENGER DOOR AJAR	GROUND	7.9 V
D PL2-1P	SERIAL COMMUNICATION INPUT		
O PL2-2P	SERIAL COMMUNICATION OUTPUT		
O SM1-1P	SQUAB RECLINE FORE /AFT MOTOR	B+ (AFT)	GROUND
O SM1-2P	SQUAB RECLINE FORE / AFT MOTOR	B+ (FORE)	GROUND
O SM1-3P	SEAT FRONT RAISE /LOWER MOTOR	B+ (UP)	GROUND
D SM1-4P	SEAT FRONT RAISE / LOWER MOTOR	B+ (DOWN)	GROUND
O SM1-5P	SEAT REAR RAISE /LOWER MOTOR	B+ (UP)	GROUND
O SM1-6P	SEAT REAR RAISE / LOWER MOTOR	B+ (DOWN)	GROUND
D SM1-7P	SEAT FORE / AFT MOTOR	B+ (AFT)	GROUND
O SM1-8P	SEAT FORE /AFT MOTDR	B+ (FORE)	GROUND
I SM1-9P	COMMON GROUND	GROUND	GROUND
O SM1-10P	HEATER ELEMENT SUPPLY	B+	B+
D SM1-11P	HEADRESTRAISE /LOWER MOTOR	B+ (UP)	GROUND
O SM1-12P	HEADRESTRAISE /LOWER MOTOR	B+ (DOWN)	GROUND
O SM6-1P	POTENTIOMETER COMMON REFERENCE VOLTAGE	5 V	5 v
SG SM6-2P	POTENTIOMETER COMMON REFERENCE GRDUND	GROUND	GROUND
O SM6-3P	HEADRESTFEEDBACK VOLTAGE	0.5 V (DOWN), 4 V (UP)	
D SM6-4P	SQUAB RECLINE FEEDBACK VOLTAGE	0.5 V (BACK), 4 V (FORWARD)	
O SM6-5P	SEAT FORE /AFT FEEDBACK VDLTAGE	0.5 V (AFT), 4 V (FORE)	
O SM6-6P	SEAT REAR RAISE /LOWER FEEDBACK VOLTAGE	0.5 V (DOWN), 4 V (UP)	
O SM6-7P	SEAT FRONT RAISE / LOWER FEEDBACK VOLTAGE	0.5 V (DOWN), 4 V (UP)	
I SM6-8P	RECLINE AFT MOVEMENT REQUEST	B+	GROUND
I SM6-9P	SEAT AFT MOVEMENT REQUEST	B+	GROUND
I SM6-10P	SEAT FORE MOVEMENT REQUEST	B+	GROUND
O SM6-11P	LUMBAR SWITCH POWER SUPPLY	B+	B+
I SM6-14P	HEADREST LOWER MOVEMENT REDUEST	B+	GROUND
I SM6-15P	HEADREST RAISE MOVEMENT REQUEST	B+	GROUND
I SM6-16P	SEAT REAR LOWER MOVEMENT REQUEST	B+	GROUND
I SM6-17P	SEAT REAR RAISE MOVEMENT REQUEST	B+	GROUND
I SM6-18P	SEAT FRONT LOWER MOVEMENT REQUEST	B+	GROUND
I SM6-19P	SEAT FRONT RAISE MOVEMENT REQUEST	B+	GROUND
I SM6-20P	RECLINE FORE MOVEMENT REQUEST	B+	GROUND

**BODY PROCESSOR MODULE**

Pin	Description	Active	Inactive
O FC1-42	PASSENGER SEAT HEATER REQUEST	GROUND	B+
I FC2-12	PASSENGER SEAT HEATER SWITCH	GROUND	B+

The following symbols are used to represent values for Control Module Pin Out data:

I	Input	Bt	Battery voltage
O	Output	V	Voltage (DC)
SG	Signal Ground	Hz	Frequency
D	Serial and encoded communications	KHz	Frequency x 1000
		MS	Milliseconds
		MV	Millivolts

**CAUTION:** The information on this data page is furnished to aid the user in understanding circuit operation. THIS INFORMATION SHOULD BE USED FOR REFERENCE ONLY.

**NOTE:** The values listed are approximately those that can be expected at the control module connector pins with all circuit connections made and all components connected and fitted. 'Active' means a load is applied or a switch is ON; 'Inactive' means a load is not applied or a switch is OFF.

**Fig. 14.5**

**COMPONENTS**

Component	Connector / Type / Color	Location / Access
BODY PROCESSOR MODULE	FC1 148-WAY PCB SIGNAL / YELLOW FC2 / 48-WAY PCB SIGNAL / BLACK FC3 / EWAY PCB SIGNAL / BLACK	PASSENGERSUNDERSUTTLE
CENTER CONSOLE SWITCH PACK	CC1 116-WAY MULTILOCK 040 / BLACK	CENTER CONSOLE
IGNITION SWITCH	FC54 (FLY LEAD) 18-WAY MULTILOCK 070 / WHITE	STEERING COLUMN / COVER
DOOR SWITCH PACK - PASSENGER	PD1 / 26-WAY MULTILOCK 41 / SLATE	ARM REST / TOP ROLL
DOOR SWITCH - PASSENGER	PD3 / 13-WAY ECONDSSEAL 111 LC / BLACK	DOOR CASING
SEAT CONTROL MODULE - PASSENGER (ROW, MEMORY SEAT VEHICLES)	PL1 / 22-WAY MULTILOCK 47 / BLUE PL2 / 2 WAY MULTILOCK 47 / BLUE SM1- / 12-WAY MULTILOCK 47 / WHITE SM6- / 22-WAY MULTILOCK 47 / WHITE	PASSENGERS SEAT
SEAT CUSHION - PASSENGER	SM7-P / 3-WAY MULTILOCK 070 / YELLOW	PASSENGERS SEAT / UNDER
SEAT LUMBAR PUMP - PASSENGER	SM10-P / 3-WAY MULTILOCK 070 / YELLOW	PASSENGERSSEAT / SQUAB
SEAT MOTORS - PASSENGER	SM2-P / 6-WAY MULTILOCK 070 / WHITE SM3-P / 6-WAY MULTILOCK 070 / YELLOW SM4-P / 6-WAY MULTILOCK 070 / SLATE SM11-P / 6-WAY MULTILOCK 070 / WHITE SM13-P / 6-WAY MULTILOCK 070 / YELLOW	PASSENGERSSEAT / UNDER PASSENGERSSEAT / UNDER PASSENGERSSEAT / UNDER PASSENGERS SEAT / SQUAB PASSENGERS SEAT / UNDER
SEAT SWITCH PACK - PASSENGER	SM5-P / 16-WAY MULTILOCK 040 / BLACK	PASSENGERSSEAT
SQUAB - PASSENGER	SM9-P / 3-WAY MULTILOCK 070 / SLATE	PASSENGERS SEAT

**HARNESS-TO-HARNESS CONNECTORS**

Connector	Type / Color	Location / Access
CA11	20-WAY MULTILOCK MO / BLACK	PASSENGERSUNDERSUTTLE / ECM
CA12	12-WAY MULTILOCK 070 / WHITE	PASSENGERSUNDERSUTTLE / ECM
CA27	6-WAY MULTILOCK 070 / WHITE	PASSENGERS SEAT
CA28	20-WAY MULTILOCK MO / BLACK	PASSENGERS SEAT
CC3	20-WAY MULTILOCK 040 / BLACK	CENTER CONSOLE / CENTER CONSOLE GLOVE BOX
CC4	14-WAY MULTILOCK 070 / WHITE	CENTER CONSOLE / CENTER CONSOLE GLOVE BOX
FC6	THROUGH-PANEL 48 MICRO / 8 / BLACK	RH FASCIA END PANEL / OUTER AIR VENT
FC7	THROUGH-PANEL 48 MICRO / 6 / BLACK	PASSENGERSUNDERSUTTLE

**GROUNDS**

Ground	Location / Type
CAG30R	LH 'A' POST GROUND SCREW
CAG33R	RH HEELBOARD GROUND SCREW
CAG92R	RH HEELBOARD GROUND SCREW
CAG93L	LH HEELBOARD GROUND SCREW
CCG51L	CENTER CONSOLE GROUND STUD
FCG15L	LH CONSOLE GROUND STUD
FCG26R	LH CONSOLE GROUND STUD
PLG3L	LH SEAT GROUND SCREW
PLG3R	LH SEAT GROUND SCREW

**CONTROL MODULE PIN OUT INFORMATION (FOLD OUT PAGE)**



REFER TO THE FRONT OF THE BOOK FOR ILLUSTRATIONS DETAILING THE LOCATION AND IDENTIFICATION OF COMPONENTS, RELAYS, CONNECTORS, HARNESSES, GROUNDS, VEHICLE CONTROL MODULES AND CONTROL MODULE PINS.

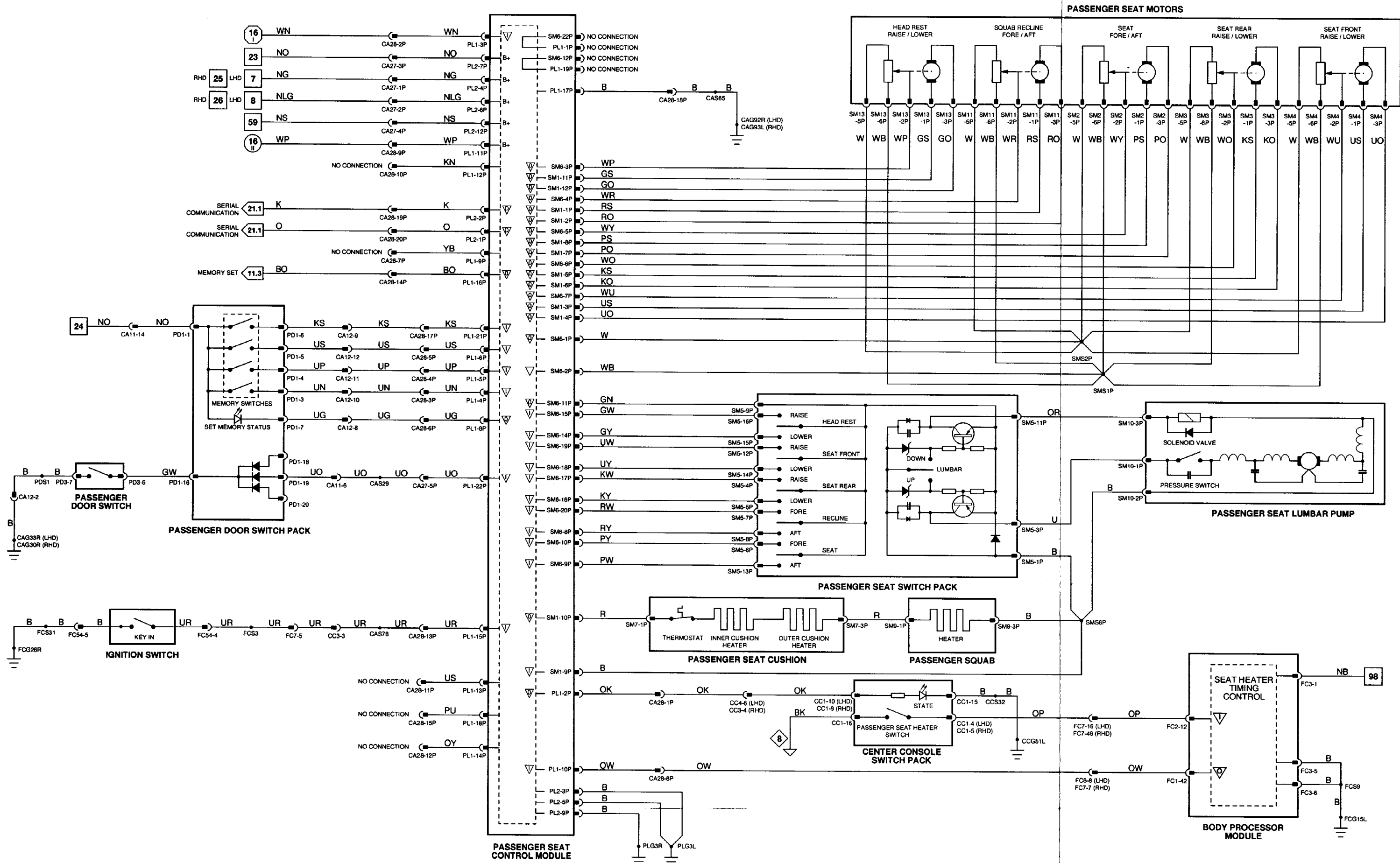

**CONTROL MODULE PIN OUT INFORMATION**

**PASSENGER SEAT CONTROL MODULE (NAS VEHICLES)**

Pin	Description	Active	Inactive
0	CA107-2	SEAT HEATER ON STATE	B+
I	CA107-3	IGNITION SWITCHED GROUND	B+
	CA107-4	MEMORY POSITION 1 REQUEST	B+
I	CA107-5	MEMORY POSITION 2 REQUEST	B+
I	CA107-6	MEMORY POSITION 3 REQUEST	B+
0	CA107-8	SEAT MEMORY STATUS STATE	B+
I	CA107-10	SEAT HEATER REDUEST	B+
I	CA107-15	KEY IN IGNITION SWITCH	B+
0	CA107-16	MEMORY SET AUDIBLE TONE	B+
I	CA107-21	SET MEMORY POSITION REQUEST	B+
I	CA107-22	PASSENGER DOOR SWITCH	B+
D	CA108-1	SERIAL COMMUNICATION INPUT	B+
0	CA108-2	SERIAL COMMUNICATION OUTPUT	B+
0	SM1-1P	SOUAB RECLINE FORE / AFT MOTOR	B+
0	SM1-2P	SOUAB RECLINE FORE / AFT MOTOR	B+
0	SM1-3P	SEAT FRONT RAISE LOWER MOTOR	B+
0	SM1-4P	SEAT FRONT RAISE LOWER MOTOR	B+
0	SM1-5P	SEAT REAR RAISE / LOWER MDTOR	B+
0	SM1-5P	SEAT REAR RAISE / LDWER MDTOR	B+
0	SM1-7P	SEAT FORE AFT MOTOR	B+
0	SM1-8P	SEAT FORE / AFT MOTOR	B+
0	SM1-9P	COMMON GROUND	B+
0	SM1-10P	HEATER ELEMENT SUPPLY	B+
0	SM1-11P	HEADREST RAISE / LOWER MOTOR	B+
0	SM1-12P	HEADREST RAISE / LOWER MOTOR	B+
0	SM6-1P	POTENTIOMETER COMMON REFERENCE VOLTAGE	B+
SG	SM6-2P	POTENTIOMETER COMMON REFERENCE GROUND	B+
0	SM6-3P	HEADREST FEEDBACK VOLTAGE	B+
0	SM6-4P	SOUAB RECLINE FEEDBACK VOLTAGE	B+
0	SM6-5P	SEAT FORE AFT FEEDBACK VOLTAGE	B+
0	SM6-6P	SEAT REAR RAISE / LOWER FEEDBACK VOLTAGE	B+
0	SM6-7P	SEAT FRONT RAISE / LOWER FEEDBACK VOLTAGE	B+
	SM6-8P	RECLINE AFT MOVEMENT REQUEST	B+
I	SM6-9P	SEAT AFT MOVEMENT REQUEST	B+
I	SM6-10P	SEAT FORE MOVEMENT REQUEST	B+
0	SM6-11P	LUMBAR SWITCH POWER SUPPLY	B+
I	SM6-14P	HEADREST LOWER MOVEMENT REQUEST	B+
	SM6-15P	HEADREST RAISE MOVEMENT REQUEST	B+
I	SM6-16P	SEAT REAR LOWER MOVEMENT REQUEST	B+
I	SM6-17P	SEAT REAR RAISE MOVEMENT REQUEST	B+
I	SM6-18P	SEAT FRONT LOWER MOVEMENT REQUEST	B+
I	SM6-19P	SEAT FRONT RAISE MOVEMENT REQUEST	B+
I	SM6-20P	RECLINE FORE MOVEMENT REQUEST	B+

**BODY PROCESSOR MODULE**

Pin	Description	Active	Inactive
0	FC1-42	PASSENGER SEAT HEATER REQUEST	B+
I	FC2-12	PASSENGER SEAT HEATER SWITCH	B+

The following symbols are used to represent values for Control Module Pin Out data:

I	Input	B+	Battery voltage
O	Output	V	Voltage (DC)
SG	Signal Ground	Hz	Frequency
D	Serial and encoded communications	KHz	Frequency x 1000
		MS	Milliseconds
		MV	Millivolts

**CAUTION:** The information on this data page is furnished to aid the user in understanding circuit operation. THIS INFORMATION SHOULD BE USED FOR REFERENCE ONLY.

**NOTE:** The values listed are approximately those that can be expected at the control module connector pins with all circuit connections made and all components connected and fitted. "Active" means a load is applied or a switch is ON; "Inactive" means a load is not applied or a switch is OFF.

**Fig. 14.6**

**COMPONENTS**

Component	Connector / Type / Color	Location / Access
BODY PROCESSOR MODULE	FC1 / 48-WAY PCB SIGNAL / YELLOW FC2 / 48-WAY PCB SIGNAL / BLACK FC3 / EWAY PCB SIGNAL 1 BLACK	PASSENGER'S UNDERSCUTTLE
CENTER CONSOLE SWITCH PACK	CC1 / 16-WAY MULTILOCK 040 / BLACK	CENTER CONSOLE
IGNITION SWITCH	FC54 (FLY LEAD) / 8-WAY MULTILOCK 0701 WHITE	STEERING COLUMN / COVER
DOOR SWITCH PACK - PASSENGER	PD1 / 26-WAY MULTILOCK 47 / SLATE	ARM REST / TOP ROLL
WOR SWITCH - PASSENGER	PD3 113-WAY ECONDSAL 111 LC / BLACK	DOOR CASING
SEAT CONTROL MODULE - PASSENGER (NAS VEHICLES)	CA107 122-WAY MULTILOCK 47 / BLUE CA108 / 12-WAY MULTILOCK 47 / BLUE SM1-P / 12-WAY MULTILOCK 47 / BLUE SM6-P / 22-WAY MULTILOCK 47 / BLUE SM7-P / 3-WAY MULTILOCK 070 / YELLOW SM10-P 13-WAY MULTILOCK 070 / YELLOW	PASSENGER'S SEAT
SEAT CUSHION - PASSENGER	SM2-P / 6-WAY MULTILOCK 070 / WHITE	PASSENGER'S SEAT UNDER
SEAT LUMBAR PUMP - PASSENGER	SM3-P / 6-WAY MULTILOCK 070 / YELLOW	PASSENGER'S SEAT / SQUAB
SEAT MOTORS - PASSENGER	SM4-P / 6-WAY MULTILOCK 070 / SLATE SM11-P / 6-WAY MULTILOCK 070 / WHITE SM13-P / 6-WAY MULTILOCK 0701 YELLOW	PASSENGER'S SEAT / UNDER PASSENGER'S SEAT / SQUAB
SEAT SWITCH PACK - PASSENGER	SMS-P116-WAY MULTILOCK 040 / BLACK	PASSENGER'S SEAT
SOUAB - PASSENGER	SM9-P / 3-WAY MULTILOCK 0701 SLATE	PASSENGER'S SEAT

**HARNESSTO-HARNESCONNECTORS**

Connector	Type / Color	Location / Access
CA11	20-WAY MULTILOCK 040 / BLACK	PASSENGER'S UNDERSCUTTLE / ECM
CA12	12-WAY MULTILOCK 070 / WHITE	PASSENGER'S UNDERSCUTTLE / ECM
CC3	20-WAY MULTILOCK 040 / BLACK	CENTER CONSOLE / CENTER CONSOLE GLOVE BOX
CC4	14-WAY MULTILOCK 070 / WHITE	CENTER CONSOLE / CENTER CONSOLE GLOVE BOX
FC6	THROUGH-PANEL (48 MICRO / 6) / BLACK	RH FASCIA END PANEL / OUTER AIR VENT
FC7	THROUGH-PANEL (48 MICRO / 6) / BLACK	PASSENGER'S UNDERSCUTTLE

**GROUNDS**

Ground	Location / Type
CAG104L	LH SEAT GROUND STUD
CAG104R	LH SEAT GROUND STUD
CAGUR	RH HEELBOARD GROUND SCREW
CAG92R	RH HEELBOARD GROUND SCREW
CCG51L	CENTER CONSOLE GROUND STUD
FCG15L	LH CONSOLE GROUND STUD
FCG26R	LH CONSOLE GROUND STUD

**CONTROL MODULE PIN OUT INFORMATION (FOLD OUT PAGE)**



REFER TO THE FRONT OF THE BOOK FOR ILLUSTRATIONS DETAILING THE LOCATION AND IDENTIFICATION OF COMPONENTS, RELAYS, HARNESSES, GROUND, VEHICLE CONTROL MODULES AND CONTROL MODULE PINS



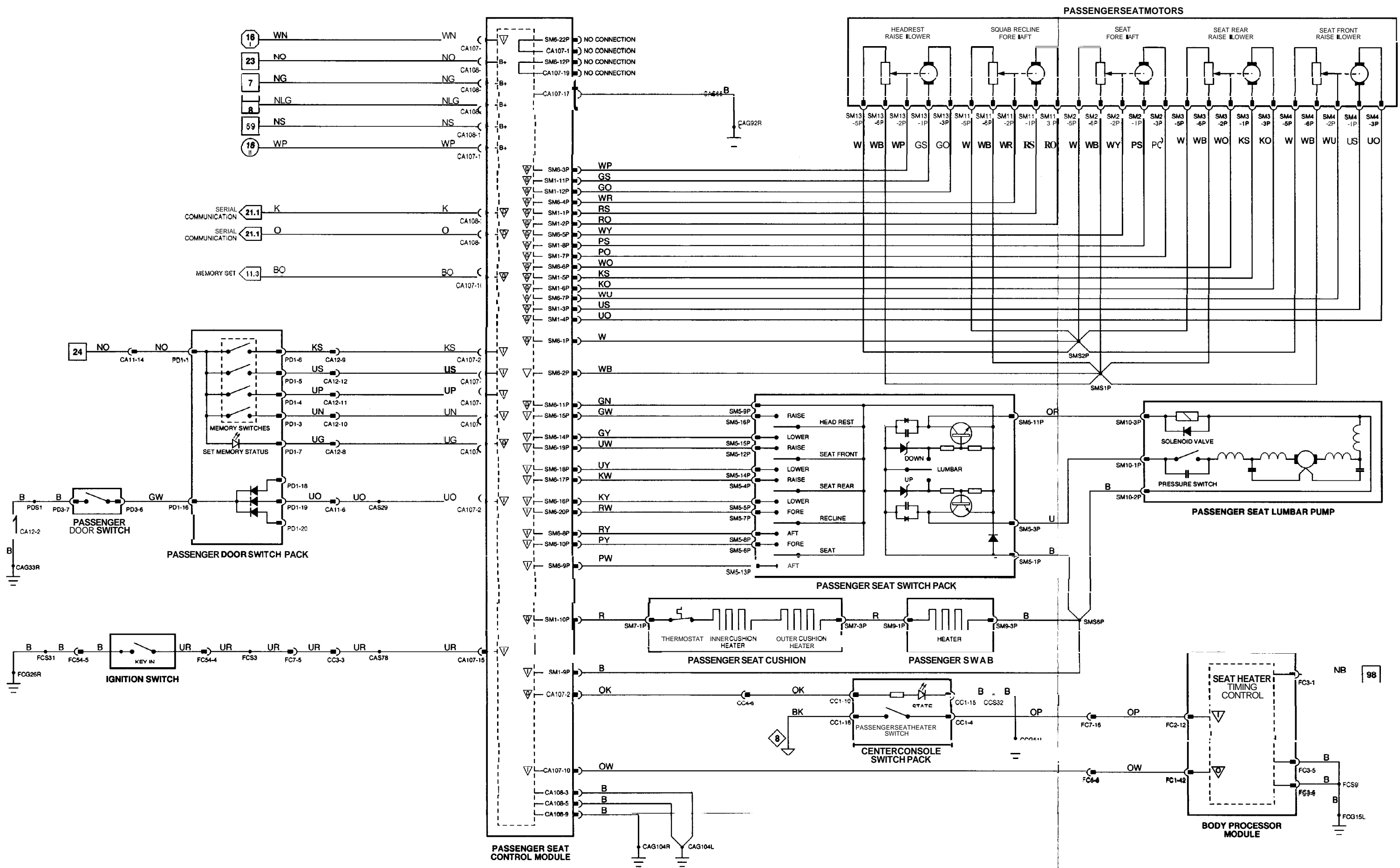

CONTROL MODULE PIN OUT INFORMATION

PASSENGER SEAT CONTROL MODULE (ROW, MEMORY SEAT VEHICLES)

Pin	Description	Active	Inactive
O PL1-2P	SEAT HEATER ON STATE	B+	GROUND
I PL1-3P	IGNITION SWITCHED W/WER	GROUND	B+
I PL1-10P	SEATHEATERREQUEST	GROUND	B+
I PL1-15P	KEY IN IGNITION SIGNAL	GROUND	B+
I PL1-22P	PASSENGER DOOR AJAR	GROUND	7.9 V
D PL2-1P	SERIAL COMMUNICATION INPUT		
D PL2-2P	SERIAL COMMUNICATION OUTPUT		
O SM1-1P	<b>SQUAB RECLINE FORE / AFT MOTOR</b>	B+ (AFT)	GROUND
O SM1-2P	<b>SQUAB RECLINE FORE / AFT MOTOR</b>	B+ (FORE)	GROUND
O SM1-3P	SEAT FRONT RAISE / LOWER MOTOR	B+ (UP)	GROUND
O SM1-4P	SEAT FRONT RAISE / LOWER MOTOR	B+ (DOWN)	GROUND
O SM1-5P	SEAT REAR RAISE / LOWER MOTOR	B+ (UP)	GROUND
O SM1-6P	SEAT REAR RAISE / LOWER MOTOR	B+ (DOWN)	GROUND
O SM1-7P	SEAT FORE / AFT MOTOR	B+ (AFT)	GROUND
O SM1-8P	SEAT FORE / AFT MOTOR	B+ (FORE)	GROUND
I SM1-9P	COMMON GROUND	GROUND	GROUND
O SM1-10P	HEATER ELEMENT SUPPLY	B+	GROUND
O SM1-11P	HEADREST RAISE / LOWER MOTOR	B+ (UP)	GROUND
O SM1-12P	HEADREST RAISE / LOWER MOTOR	B+ (DOWN)	GROUND
I SM6-8P	RECLINE AFT MOVEMENT REQUEST	B+	GROUND
I SM6-9P	SEAT AFT MOVEMENT REQUEST	B+	GROUND
I SM6-10P	SEAT FORE MOVEMENT REQUEST	B+	GROUND
D SM6-11P	LUMBAR SWITCH W/WER SUPPLY	B+	GROUND
I SM6-14P	HEADREST LOWER MOVEMENT REQUEST	B+	GROUND
I SM6-15P	HEADREST RAISE MOVEMENT REQUEST	B+	GROUND
I SM6-16P	SEAT REAR LOWER MOVEMENT REQUEST	B+	GROUND
I SM6-17P	SEAT REAR RAISE MOVEMENT REQUEST	B+	GROUND
I SM6-18P	SEAT FRONT LOWER MOVEMENT REQUEST	B+	GROUND
I SM6-19P	SEAT FRONT RAISE MOVEMENT REQUEST	B+	GROUND
I SM6-20P	RECLINE FORE MOVEMENT REQUEST	B+	GROUND

BODY PROCESSOR MODULE

Pin	Description	Active	Inactive
O FC1-42	PASSENGERSEATHEATERREQUEST	GROUND	B+
I FC2-12	PASSENGERSEAT HEATER SWITCH	GROUND	B+

The following symbols are used to represent values for Control Module Pin Out data:

I	Input	B+	Battery voltage
O	Output	V	Voltage (DC)
SG	Signal Ground	Hz	Frequency
D	Serial and encoded communications	KHz	Frequency x 1000
		MS	Milliseconds
		MV	Millivolts

CAUTION: The information on this data page is furnished to aid the user in understanding circuit operation. THIS INFORMATION SHOULD BE USED FOR REFERENCE ONLY.

NOTE: The values listed are approximately those that can be expected at the control module connector pins with all circuit connections made and all components connected and fitted. "Active" means a load is applied or a switch is ON; "Inactive" means a load is not applied or a switch is OFF.

Fig. 14.7

COMPONENTS

Component	Connector / Type Color	Location / Access
BODY PROCESSOR MODULE	FC1 48-WAY PCB SIGNAL 1 YELLOW FC2 48-WAY PCB SIGNAL 1 BLACK FC3 6-WAY PCB SIGNAL 1 BLACK	PASSENGER'S UNDERSCUTTLE
CENTER CONSOLE SWITCH PACK	CC1 16-WAY MULTILOCK 040 BLACK CC2 16-WAY MULTILOCK 040 BLACK CC3 16-WAY MULTILOCK 040 BLACK	CENTER CONSOLE
IGNITION SWITCH	FC54 (FLY LEAD) 18-WAY MULTILOCK 0701 WHITE	STEERING COLUMN COVER
DOOR SWITCH - PASSENGER	PD3 13-WAY ECONOSEAL III LC BLACK	DOOR CASING
DOOR SWITCH PACK - PASSENGER	PD1 26-WAY MULTILOCK 47 SLATE	ARM REST / TOP ROLL
SEAT CONTROL MODULE - PASSENGER (ROW, MEMORY SEAT VEHICLES)	PL1 22-WAY MULTILOCK 47 BLUE PL2 12-WAY MULTILOCK 47 BLUE SM1-P 12-WAY MULTILOCK 47 WHITE SM6-P 12-WAY MULTILOCK 47 WHITE SM7-P 15-WAY MULTILOCK 070 YELLOW SM10-P 3-WAY MULTILOCK 070 YELLOW SM2-P 6-WAY MULTILOCK 070 WHITE SM3-P 6-WAY MULTILOCK 0701 YELLOW SM4-P 6-WAY MULTILOCK 0701 SLATE SM11-P 6-WAY MULTILOCK 070 WHITE SM13-P 6-WAY MULTILOCK 070 YELLOW	PASSENGER'S SEAT
SEAT CUSHION - PASSENGER	SM5-P 15-WAY MULTILOCK 040 BLACK	PASSENGER'S SEAT / UNDER PASSENGER'S SEAT / SQUAB
SEAT LUMBAR PUMP - PASSENGER	SM9-P 3-WAY MULTILOCK 0701 SLATE	PASSENGER'S SEAT / UNDER PASSENGER'S SEAT / SQUAB
SEAT MOTORS - PASSENGER		PASSENGER'S SEAT / UNDER PASSENGER'S SEAT / SQUAB
SEAT SWITCH PACK - PASSENGER		PASSENGER'S SEAT / UNDER PASSENGER'S SEAT
SQUAB - PASSENGER		PASSENGER'S SEAT

HARNESSTO-HARNESCONNECTORS

Connector	Type Color	Location Access
CA11	20-WAY MULTILOCK MO / BLACK	PASSENGER'S UNDERSCUTTLE IECM
CA12	12-WAY MULTILOCK 0701 WHITE	PASSENGER'S UNDERSCUTTLE IECM
CA27	6-WAY MULTILOCK 070 WHITE	PASSENGER'S SEAT
CA26	20-WAY MULTILOCK MO BLACK	PASSENGER'S SEAT
CC3	20-WAY MULTILOCK MO BLACK	CENTER CONSOLE / CENTER CONSOLE GLOVE BOX
CC4	14-WAY MULTILOCK 070 WHITE	CENTER CONSOLE / CENTER CONSOLE GLOVE BOX
FC6	THROUGH-PANEL (48 MICRO / 6) BLACK	RH FASCIA END PANEL / OUTER AIR VENT
FC7	THROUGH-PANEL (48 MICRO / 6) BLACK	PASSENGER'S UNDERSCUTTLE

GROUNDS

Ground	Location Type
CAG30R	LH 'A' PDST GROUND SCREW
CAG33R	RH HEELBOARD GROUND SCREW
CAG92R	RH HEELBOARD GROUND SCREW
CAG93L	LH HEELBOARD GROUND SCREW
CCG51L	CENTER CONSOLE GROUND STUD
FCG15L	LH CONSOLE GROUND STUD
FCG26R	LH CONSOLE GROUND STUD
PLGY	LH SEAT GROUND SCREW
PLG3R	LH SEAT GROUND SCREW

CONTROL MODULE PIN OUT INFORMATION (FOLDOUT PAGE)



REFER TO THE FRONT OF THE BOOK FOR ILLUSTRATIONS DETAILING THE LOCATION AND IDENTIFICATION OF COMPONENTS, RELAYS, CONNECTORS, HARNESSES, GROUNDS, VEHICLE CONTROL MODULES AND CONTROL MODULE PINS.

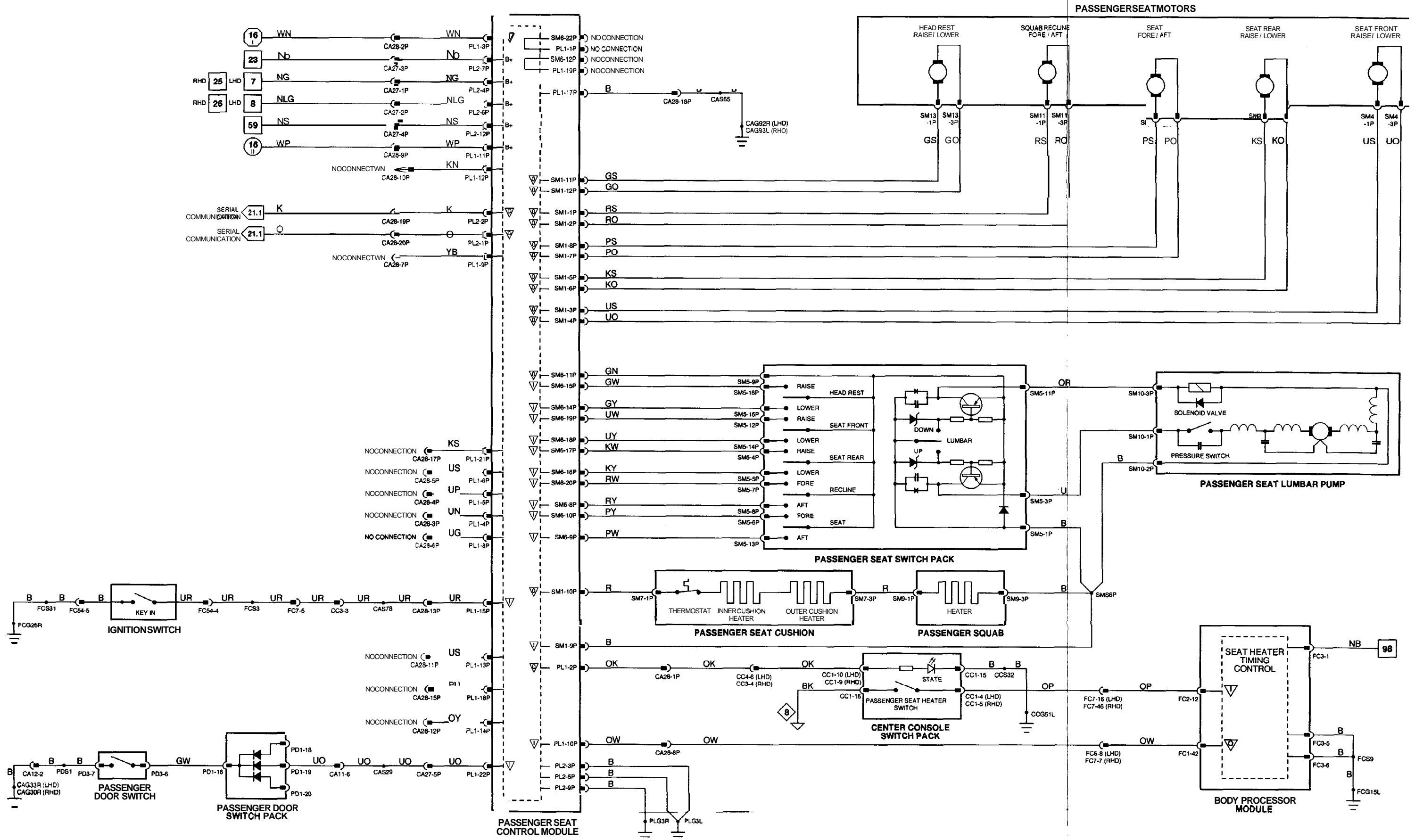

CONTROL MODULE PIN OUT INFORMATION

BODY PROCESSOR MODULE

Pin	Description	Active	Inactive
O FC1-42	PASSENGER SEAT HEATER REQUEST	GROUND	B+
I FCZ-12	PASSENGER SEAT HEATER SWITCH	GROUND	B+

**Fig. 14.8**

COMPONENTS

Component	Connector ■Type ■Color	Location ■Access
BODY PROCESSOR MODULE	FC1 / 48-WAY PCB SIGNAL / YELLOW FC2 148-WAY PCB SIGNAL / BLACK F U ■SWAY PCB SIGNAL/ BLACK	PASSENGER'S UNDERSCUTTLE
CENTER CONSOLE SWITCHPACK	CC1 / 18-WAY MULTILOCK040 / BLACK	CENTER CONSOLE
SEAT CUSHION -PASSENGER	SM7-P / 3-WAY MULTILOCK070 / YELLOW	PASSENGER'S SEAT / UNDER
SEAT MOTOR -PASSENGER (SEAT RAISE ■LOWER VEHICLES)	SM16-P / 6-WAY MULTILOCK 070 / SLATE	PASSENGER'S SEAT / UNDER
SEAT SWITCH PACK - PASSENGER (SEAT RAISE ■LOWER VEHICLES)	SM17-P / 16-WAY MULTILOCK040 / BLACK	PASSENGER'S SEAT
SQUAB - PASSENGER	SM9-P / 3-WAY MULTILOCK070 ■SLATE	PASSENGER'S SEAT

RELAYS

Relay	Color / Stripe	Connector / Color	Location ■Access
SEAT HEATER RELAY - PASSENGER	BLACK	SM18-P / BLUE	PASSENGER'S SEAT
SEAT LOWER RELAY - PASSENGER	BLACK / VIOLET	SM14-P / BLUE	PASSENGER'S SEAT
SEAT RAISE RELAY - PASSENGER	BLACK / VIOLET	SM14-P / BLUE	PASSENGER'S SEAT

HARNESS-TO-HARNESSCONNECTORS

Connector	Type / Color	Location ■Access
CA27	6-WAY MULTILOCK070 / WHITE	PASSENGER'S SEAT
CA28	20-WAY MULTILOCK040 ■BLACK	PASSENGER'S SEAT
CC3	20-WAY MULTILOCK MO ■BLACK	CENTER CONSOLE1 CENTER CONSOLE GLOVE BOX
CC4	14-WAY MULTILOCK070 / WHITE	CENTER CONSOLE1 CENTER CONSOLE GLOVE BOX
FC8	THROUGH-PANEL48 MICRO/ 6) ■BLACK	RH FASCIA END PANEL ■OUTER AIR VENT
FC7	THROUGH-PANEL48 MICRO ■) / BLACK	PASSENGER'S UNDERSCUTTLE
ML1-P	10-WAY MULTILOCK070 ■WHITE	PASSENGER'S SEAT / UNDER

GROUNDS

Ground	Location ■Type
CCG51L	CENTER CONSOLE GROUND STUD
FCG15L	LH CONSOLE GROUND STUD
MLG2L	LH SEAT GROUND SCREW
MLG2R	LH SEAT GROUND SCREW

CONTROL MODULE PIN OUT INFORMATION (FOLD OUT PAGE)



The following symbols are used to represent values for Control Module Pin Out data:

I	Input	B+	Battery voltage
O	Output	V	Voltage (DC)
SG	SignalGround	Hz	Frequency
D	Serialand encoded communications	KHz	Frequency x 1000
		MS	Milliseconds
		MV	Millivolts

CAUTION: The information on this data page is furnished to aid the user in understanding circuit operation. THIS INFORMATION SHOULD BE USED FOR REFERENCE ONLY.

NOTE: The values listed are approximately those that can be expected at the control module connector pins with all circuit connections made and all components connected and fitted. 'Active' means a load is applied or a switch is ON; 'Inactive' means a load is not applied or a switch is OFF.

REFER TO THE FRONT OF THE BOOK FOR ILLUSTRATIONS DETAILING THE LOCATION AND IDENTIFICATION OF COMPONENTS, RELAYS, CONNECTORS, HARNESSES, GROUNDS, VEHICLE CONTROL MODULES AND CONTROL MODULE PINS.

DATE OF ISSUE: JANUARY 1995

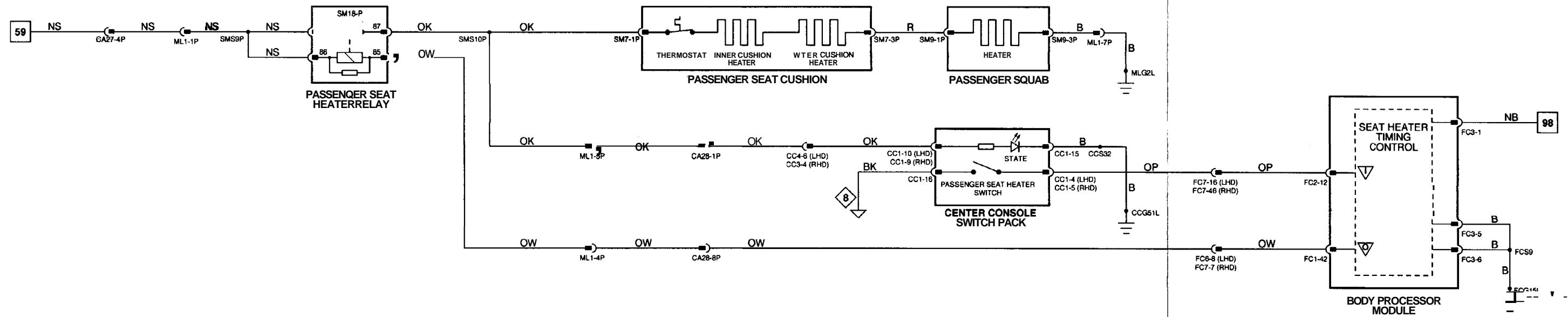
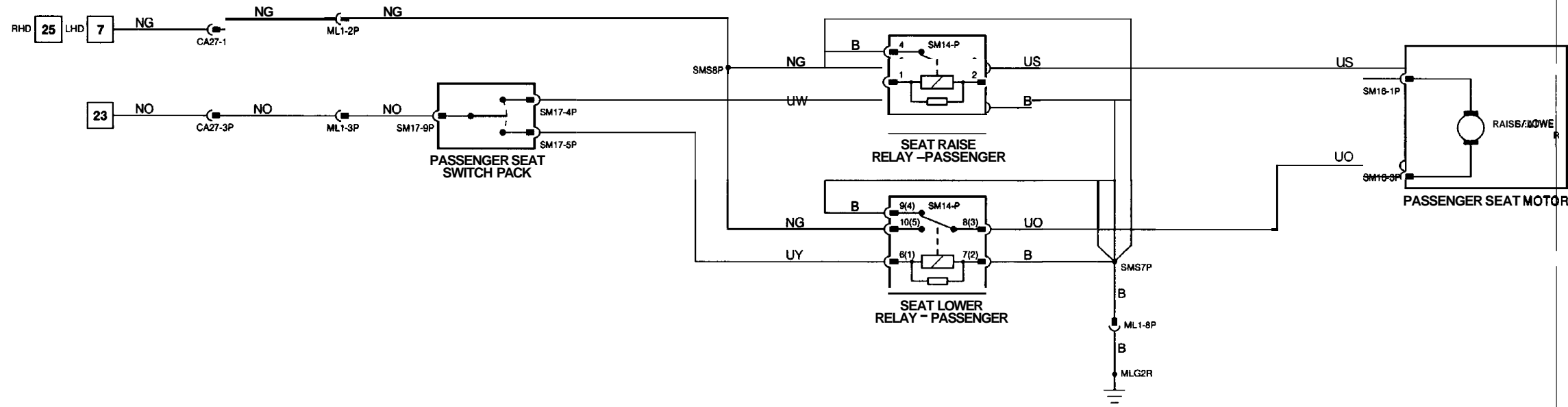

CONTROL MODULE PIN OUT INFORMATION

BODY PROCESSOR MODULE

Pin	Description	Active	Inactive
FC1-42	PASSENGER SEAT HEATER REQUEST	GROUND	B+
FC2-12	PASSENGER SEAT HEATER SWITCH	GROUND	B+

**Fig. 14.9**

COMPONENTS

Component	Connector ■Type ■Color	Location ■Access
BODY PROCESSOR MODULE	FC1 / 48-WAY PCB SIGNAL / YELLOW FC2 / 48-WAY PCB SIGNAL / BLACK FC3 / 6-WAY PCB SIGNAL / BLACK	PASSENGERS UNDERSCUTTLE
CENTER CONSOLE SWITCH PACK	CC1 / 18-WAY MULTILOCK040 / BLACK	CENTER CONSOLE
SEAT CUSHION -PASSENGER	SM7-P / 3-WAY MULTILOCK070 / YELLOW	PASSENGERS SEAT/UNDER
SEAT CUSHION - PASSENGER	SM9-P / 3-WAY MULTILOCK 070 / SLATE	PASSENGERS SEAT

RELAYS

Relay	Color / Stripe	Connector / Color	Location / Access
SEAT HEATER RELAY - PASSENGER	BLACK	SM18-P / BLUE	PASSENGERS SEAT

HARNESS-TO-HARNESSCONNECTORS

Connector	Type ■Color	Location ■Access
CA27	6-WAY MULTILOCK070 / WHITE	PASSENGERS SEAT
CA28	20-WAY MULTILOCK040 ■BLACK	PASSENGERS SEAT
CC3	20-WAY MULTILOCK040 ■BLACK	CENTER CONSOLE ■CENTER CONSOLE GLOVE BOX
CC4	11-WAY MULTILOCK070 / WHITE	CENTER CONSOLE ■CENTER CONSOLE GLOVE BOX
FC6	THROUGH-PANEL (48 MICRO / 6) ■BLACK	RH FASCIA END PANEL / OUTER AIR VENT
FC7	THROUGH-PANEL (48 MICRO / 6) / BLACK	PASSENGER'S UNDERSCUTTLE
ML1-P	10-WAY MULTILOCK070 / WHITE	PASSENGERS SEAT / UNDER

GROUND

Ground	Location / Type
CCG51L	CENTER CONSOLE GROUND STUD
FCG15L	LH CONSOLE GROUND STUD
MLG2L	LH SEATGROUND SCREW

CONTROL MODULE PIN OUT INFORMATION (FOLD OUT PAGE)



all components connected and fitted. 'Active' means a load is applied or a switch is ON; 'Inactive' means a load is not applied or a switch is OFF.

TO THE FRONT OF THE BOOK FOR ILLUSTRATIONS DETAILING THE LOCATION AND IDENTIFICATION OF COMPONENTS, RELAYS, CONNECTORS, SEAT GROUND, VEHICLE CONTROL MODULES AND CONTROL MODULE PINS.

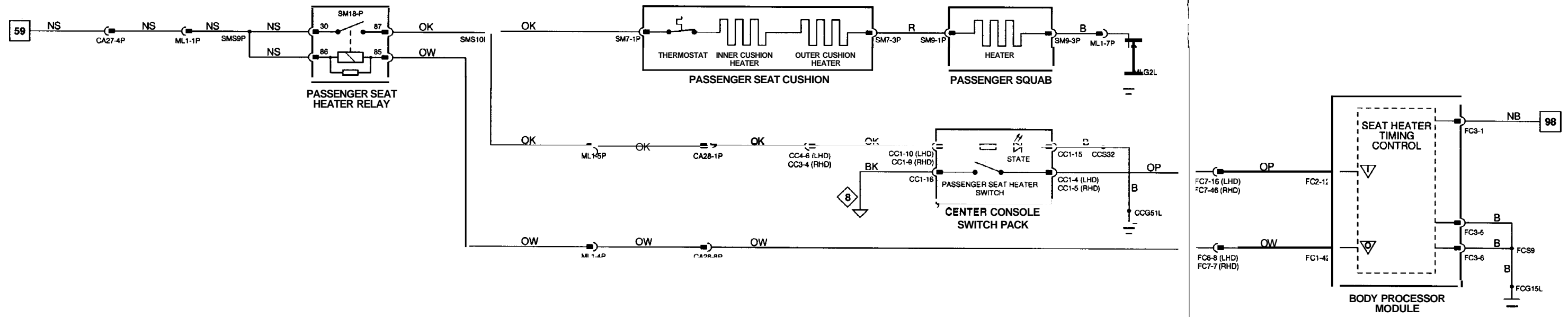

CONTROL MODULE PIN OUT INFORMATION

SECURITY AND LOCKING CONTROL MODULE

Pin	Description	Active	Inactive
I CA18-2	EXTERNAL TRUNK LID SWITCH	GROUND	1.74 V
I CA18-3	NOT IN PARK MICROSWITCH	GROUND	B+
I CA18-4	PASSENGER DOOR LOCK STATUS	GROUND = LOCKED	1.74 V = UNLOCKED
I CA18-5	PASSENGER DOOR LOCK BARREL UNLOCK / DISARM REQUEST	MOMENTARY GROUND	1.74 V
I CA18-6	DRIVER DOOR LOCK BARREL UNLOCK / DISARM REQUEST	MOMENTARY GROUND	1.74 V
I CA18-10	DRIVER DOOR LOCK STATUS	GROUND = LOCKED	1.74 V = UNLOCKED
I CA18-11	PASSENGER DOOR LOCK BARREL LOCK / ARM REQUEST	MOMENTARY GROUND	1.74 V
I CA18-12	DRIVER DOOR LOCK BARREL LOCK / ARM REQUEST	MOMENTARY GROUND	1.74 V
O CA19-1	FUEL FILLER FLAP LOCK REQUEST	GROUND PULSE	B+
I CA19-6	VALET SWITCH	MOMENTARY GROUND	2 V
I CA19-8	FASCIA TRUNK RELEASE SWITCH	MOMENTARY GROUND	2.7 V
I CA19-13	KEY IN IGNITION SWITCH	GROUND	9.5 V
I CA19-19	CENTRAL LOCKING SWITCH ALL CLOSE REQUEST	GROUND	B+
O CA19-22	DOOR UNLOCK RELAY	GROUND PULSE	B+
D CA20-8	SERIAL COMMUNICATION INPUT		
D CA20-16	SERIAL COMMUNICATION OUTPUT		
O CA21-1	RHF & LHR DOOR DEADLOCK RELAY (NOT NASH)	GROUND PULSE	B+
I CA21-5	VEHICLE SPEED INPUT	B+ @ 10 MPH = 20 Hz, 20 MPH = 40 Hz	
O CA21-11	TRUNK RELEASE RELAY	GROUND PULSE	B+
O CA21-14	LHF & RHR DOOR DEADLOCK RELAY	GROUND PULSE	B+
O CA21-15	DOOR LOCK RELAY	GROUND PULSE	B+

Fig. 15.1

COMPONENTS

Component	Connector / Type / Color	Location / Access
CEMER CONSOLE SWITCH PACK	CC1 / 16-WAY MULTILOCK 040 / BLACK	CENTER CONSOLE
DOOR KEY BARREL SWITCH - DRIVER	DD3 / 13-WAY ECONOSEAL III LC / BLACK	W/O CASING
DOOR KEY BARREL SWITCH - PASSENGER	PD3113-WAY ECONOSEAL III LC / BLACK	DOOR CASING
DOOR LOCK ACTUATOR - DRIVER	DD3 / 13-WAY ECONOSEAL III LC / BLACK	DOOR CASING
DOOR LOCK ACTUATOR - LH REAR	RD3-L / 6-WAY ECONOSEAL III LC / BLACK	DOOR CASING
DOOR LOCK ACTUATOR - PASSENGER	PD3 / 13-WAY ECONOSEAL III LC / BLACK	DOOR CASING
DOOR LOCK ACTUATOR - RH REAR	RD3-R / 6-WAY ECONOSEAL III LC / BLACK	DOOR CASING
FASCIA TRUNK RELEASE SWITCH	FC12 / 16-WAY MULTILOCK 040 / BLUE	STEERING COLUMN / DRIVER'S UNDERSCUTTLE
FUEL FILLER FLAP ACTUATOR	CA88 / 2-WAY LABINAL / NATURAL	TRUNK / LF FRONT / TRUNK TRIM
IGNITION SWITCH	FC54 (FLY LEAD) / 18-WAY MULTILOCK 070 / WHITE	STEERING COLUMN / COVER
NOT IN-PARK MICROSWITCH	CC42 (FLY LEAD) / 2-WAY MULTILOCK 040 / BLACK	'J' GATE / CENTER CONSOLE
SECURITY AND LOCKING CONTROL MODULE	CA18 / 12-WAY MULTILOCK 47 / SLATE CA19 / 22-WAY MULTILOCK 47 / SLATE CA20 / 16-WAY MULTILOCK 47 / SLATE CA21 126-WAY MULTILOCK 47 / SLATE	TRUNK / LH FRONT / TRUNK TRIM
SHORTING LINK	CA431 6-WAY MULTILOCK 070 / YELLOW	REAR SEAT, LH SIDE / UNDER
TRUNK RELEASE ACTUATOR	BT8 / 2-WAY LABINAL / BROWN	TRUNK LID / TRUNK LID TRIM
TRUNK RELEASE SWITCH	BT10 / 2-WAY MULTILOCK 040 / GREEN	TRUNK LID / TRUNK LID TRIM
VALET SWITCH	CC47 / 2-WAY MULTILOCK 040 / BLACK	CEMER CONSOLE GLOVE BOX

RELAYS

Relay	Color / Stripe	Connector / Color	Location / Access
DEADLOCK RELAY - DRIVER, RH REAR	VIOLET	CA55 / VIOLET	
DEADLOCK RELAY - PASSENGER, LH REAR	VIOLET	CA55 / VIOLET	LH HEELBOARD
DOOR LOCK RELAY	VIOLET	CA50 / VIOLET	LH HEELBOARD
DOOR UNLOCK RELAY	VIOLET	CA50 / VIOLET	
FUEL FILLER FLAP RELAY	VIOLET	CA97 / VIOLET	LH HEELBOARD
TRUNK RELEASE RELAY	BLACK / VIOLET	BT U / VIOLET	TRUNK ELECTRICAL CARRIER

HARNESS-TO-HARNESS CONNECTORS

Connector	Type / Color	Location / Access
BT4	THROUGH-PANEL 48 MICRO / 6 / BLACK	PARCEL SHELF / FUEL TANK TRIM
CA8	20-WAY MULTILOCK 040 / GREEN	DRIVER'S UNDERSCUTTLE
CA9	20-WAY MULTILOCK 040 / BLACK	DRIVER'S 'A' POST / 'A' POST TRIM
CA11	20-WAY MULTILOCK 040 / BLACK	PASSENGER'S UNDERSCUTTLE / ECM
CA12	12-WAY MULTILOCK 070 / WHITE	PASSENGER'S UNDERSCUTTLE / ECM
CA13	12-WAY MULTILOCK 040 / BLACK	LH 'BC' POST / 'BC' POST PANEL
CA15	12-WAY MULTILOCK MO1 / BLACK	RH 'BC' POST / 'BC' POST PANEL
CC1	20-WAY MULTILOCK 040 / BLUE	CENTER CONSOLE / CENTER CONSOLE
CC3	20-WAY MULTILOCK 040 / BLACK	CENTER CONSOLE / CENTER CONSOLE GLOVE BOX
CC5	20-WAY MULTILOCK MO / GREEN	CENTER CONSOLE / CENTER CONSOLE GLOVE BOX
FC5	THROUGH-PANEL 48 MICRO / 6 / BLACK	LH FASCIA END PANEL / OUTER AIR VENT
FC7	THROUGH-PANEL 48 MICRO / 6 / BLACK	PASSENGER'S UNDERSCUTTLE

GROUNDS

Ground	Location / Type
BT49L	REAR TRUNK GROUND STUD
CA91	PARCEL SHELF GROUND SCREW
CAG92R	RH HEELBOARD GROUND SCREW
CAG93L	LH HEELBOARD GROUND SCREW
CCG51L	CENTER CONSOLE GROUND STUD
FCG15L	LH CONSOLE GROUND STUD
FCG26R	LH CONSOLE GROUND STUD

CONTROL MODULE PIN OUT INFORMATION (FOLD OUT PAGE)



The following symbols are used to represent values for Control Module Pin Out data:

I	Input	B+	Battery voltage
O	Output	V	Voltage (DC)
SG	Signal Ground	Hz	Frequency
D	Serial and encoded communications	KHz	Frequency x 1000
		MS	Milliseconds
		MV	Millivolts

CAUTION: The information on this data page is furnished to aid the user in understanding circuit operation. THIS INFORMATION SHOULD BE USED FOR REFERENCE ONLY.

NOTE: The values listed are approximately those that can be expected at the control module connector pins with all circuit connections made and fitted. "Active" means a load is applied or a switch is ON; "Inactive" means a load is not applied or a switch is OFF.

REFER TO THE FRONT OF THE BOOK FOR ILLUSTRATIONS DETAILING THE LOCATION AND IDENTIFICATION OF COMPONENTS, RELAYS, CONNECTORS, HARNESSES, GROUNDS, VEHICLE CONTROL MODULE AND CONTROL MODULE PINS.

DATE OF ISSUE: JANUARY 1995



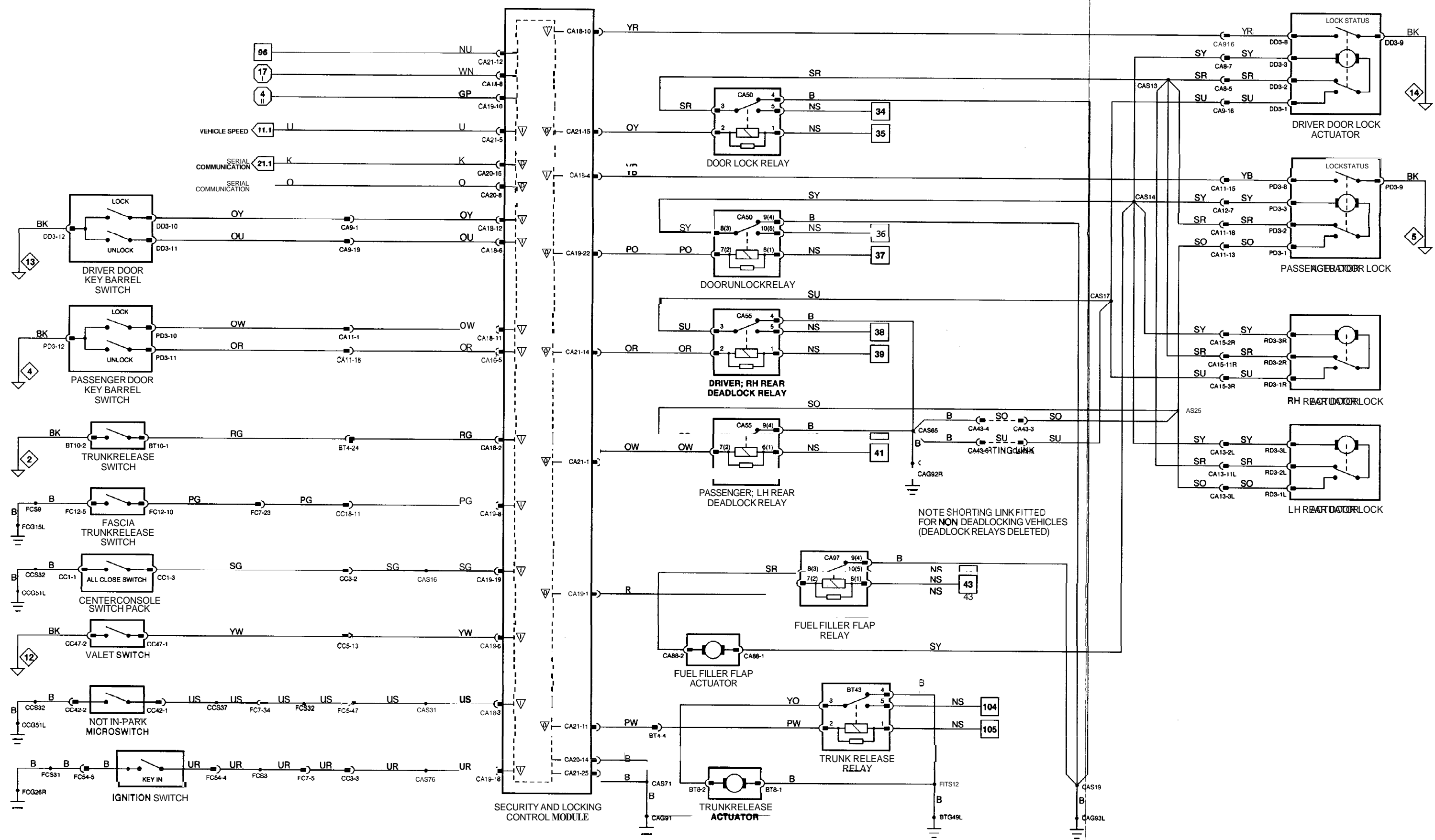

CONTROL MODULE PIN OUT INFORMATION

SECURITY AND LOCKING CONTROL MODULE

Pin	Description	Active	Inactive
I CA18-2	EXTERNAL TRUNK LID SWITCH	GROUND	1.74 V
I CA18-3	NOT IN PARK MICROSWITCH	GROUND	B+
I CA18-4	PASSENGER DOOR LOCK STATUS	GROUND - LOCKED	1.74 V - UNLOCKED
I CA18-5	PASSENGER DOOR LOCK BARREL UNLOCK / DISARM REQUEST	MOMENTARY GROUND	1.74 V
I CA18-6	DRIVER DOOR LOCK BARREL UNLOCK / DISARM REQUEST	MOMENTARY GROUND	1.74 V
I CA18-10	DRIVER DOOR LOCK STATUS	GROUND - LOCKED	1.74 V - UNLOCKED
I CA18-11	PASSENGER W O R LOCK BARREL LOCK / ARM REQUEST	MOMENTARY GROUND	1.74 V
I CA18-12	DRIVER W O R LOCK BARREL LOCK ARM REQUEST	MOMENTARY GROUND	1.74 V
O CA19-1	FUEL FILLER FLAP LOCK REQUEST	GROUND PULSE	B+
I CA19-6	VALET SWITCH	MOMENTARY GROUND	2 V
I CA19-8	FASCIA TRUNK RELEASE SWITCH	MOMENTARY GROUND	2.7 V
I CA19-18	KEY IN IGNITION SWITCH	GROUND	9.5 V
I CA19-19	CENTRAL LOCKING SWITCH ALL CLOSE REQUEST	GROUND	B+
O CA19-22	DOOR UNLOCK RELAY	GROUND PULSE	B+
D CA20-8	SERIAL COMMUNICATION INPUT		
D CA20-16	SERIAL COMMUNICATION OUTPUT		
O CA21-2	DRIVER DOOR UNLOCK RELAY (TWO STAGE REMOTE UNLOCKING)	GROUND PULSE	B+
I CA21-5	VEHICLE SPEED INPUT	B+ @ 10 MPH = 20 Hz 20 MPH = 40 Hz	
O CA21-11	TRUNK RELEASE RELAY	GROUND PULSE	B+
O CA21-15	DOOR LOCK RELAY	GROUND PULSE	B+

Fig. 15.2

COMPONENTS

Component	Connector / Type Color	Location / Access
CENTER CONSOLE SWITCH PACK	CC1 16-WAY MULTILOCK 040 / BLACK	CENTER CONSOLE
DOOR KEY BARREL SWITCH - DRIVER	DD3 / 13-WAY ECONOSEAL 111 LC / BLACK	DOOR CASING
W O R KEY BARREL SWITCH - PASSENGER	PD3 / 13-WAY ECONOSEAL 111 LC / BLACK	DOOR CASING
DOOR LOCK ACTUATOR - DRIVER	DD3 13-WAY ECONOSEAL 111 LC / BLACK	DOOR CASING
DOOR LOCK ACTUATOR - LH REAR	RD3-L / 6-WAY ECONOSEAL 111 LC / BLACK	DOOR CASING
DOOR LOCK ACTUATOR - PASSENGER	PD3 13-WAY ECONOSEAL 111 LC / BLACK	DOOR CASING
DOOR LOCK ACTUATOR - RH REAR	RD3-R 16-WAY ECONOSEAL 111 LC / BLACK	DOOR CASING
FASCIA TRUNK RELEASE SWITCH	FC12 / 16-WAY MULTILOCK 040 / BLUE	STEERING COLUMN / DRIVERS' UNDERSCUTTLE
FUEL FILLER FLAP ACTUATOR	CA88 12-WAY LABINAL NATURAL	TRUNK, LF FRONT TRUNK TRIM
IGNITION SWITCH	FCY (FLY LEAD) 12-WAY MULTILOCK 070 / WHITE	STEERING COLUMN / COVER
NOT IN PARK MICROSWITCH	CC42 (FLY LEAD) 12-WAY MULTILOCK 040 / BLACK	'J' GATE CENTER CONSOLE
SECURITY AND LOCKING CONTROL MODULE	CA18 / 12-WAY MULTILOCK 47 / SLATE CA19 122-WAY MULTILOCK 47 / SLATE CA20 / 16-WAY MULTILOCK 47 / SLATE CA21 / 26 WAY MULTILOCK 47 / SLATE	TRUNK, LH FRONT / TRUNK TRIM
TRUNK RELEASE ACTUATOR	BTB1 2 WAY LABINAL BROWN	TRUNK LID / TRUNK LID TRIM
TRUNK RELEASE SWITCH	BT10 / 2 WAY MULTILOCK 040 / GREEN	TRUNK LID / TRUNK LID TRIM
VALET SWITCH	CC47 12-WAY MULTILOCK 040 / BLACK	CENTER CONSOLE GLOVE BOX

RELAYS

Relay	Color / Stripe	Connector / Color	Location / Access
DRIVER DOOR UNLOCK RELAY	VIOLET	CA71 VIOLET	LH HEELBOARD
DOOR LOCK RELAY	VIOLET	CA50 / VIOLET	LH HEELBOARD
DOOR UNLOCK RELAY	VIOLET	CA50 / VIOLET	
FUEL FILLER FLAP RELAY	VIOLET	CA97 / VIOLET	LH HEELBOARD
TRUNK RELEASE RELAY	BLACK / VIOLET	BT43 / VIOLET	TRUNK ELECTRICAL CARRIER

HARNESS-TO-HARNESS CONNECTORS

Connector	Type / Color	Location / Access
BT4	THROUGH-PANEL (48 MICRO / 6) / BLACK	PARCEL SHELF / FUEL TANK TRIM
CA8	20-WAY MULTILOCK 040 / GREEN	DRIVERS' UNDERSCUTTLE
CA9	20-WAY MULTILOCK 040 / BLACK	DRIVERS' A POST / A POST TRIM
CA11	20-WAY MULTILOCK 040 / BLACK	PASSENGER'S UNDERSCUTTLE / ECM
CA12	12-WAY MULTILOCK 070 / WHITE	PASSENGER'S UNDERSCUTTLE / ECM
CA13	12-WAY MULTILOCK 040 / BLACK	LH 'BC' POST / 'BC' POST PANEL
CA15	12-WAY MULTILOCK 040 / BLACK	RH 'BC' POST / 'BC' POST PANEL
CC18	20-WAY MULTILOCK 040 / BLUE	CENTER CONSOLE / CENTER CONSOLE
CC3	20-WAY MULTILOCK 040 / BLACK	CENTER CONSOLE / CENTER CONSOLE GLOVE BOX
CC5	20-WAY MULTILOCK 040 / GREEN	CENTER CONSOLE / CENTER CONSOLE GLOVE BOX
FC5	THROUGH-PANEL (48 MICRO / 6) / BLACK	LH FASCIA END PANEL / OUTER AIR VENT
FC7	THROUGH-PANEL (48 MICRO / 6) / BLACK	PASSENGER'S UNDERSCUTTLE

GROUNDS

Ground	Location / Type
BTG49L	REAR TRUNK GROUND STUD
CAG91	PARCEL SHELF GROUND SCREW
CAG92R	RH HEELBOARD GROUND SCREW
CAG93L	LH HEELBOARD GROUND SCREW
CCG51L	CENTER CONSOLE GROUND STUD
FCG15L	LH CONSOLE GROUND STUD
FCG26R	LH CONSOLE GROUND STUD

CONTROL MODULE PIN OUT INFORMATION (FOLD OUT PAGE)



The following symbols are used to represent values for Control Module Pin Out data:

I	Input	B+	Battery voltage
O	Output	V	Voltage (DC)
SG	Signal Ground	Hz	Frequency
D	Serial and encoded communications	KHz	Frequency x 1000
		MS	Milliseconds
		MV	Millivolts

CAUTION: The information on this data page is furnished to aid the user in understanding circuit operation. THIS INFORMATION SHOULD BE USED FOR REFERENCE ONLY.

NOTE: The values listed are approximately those that can be expected at the control module connector pins with all circuit connections made and all components connected and fixed. "Active" means a load is applied or a switch is ON; "Inactive" means a load is not applied or a switch is OFF.

TO THE FRONT OF THE BODY, HAF ; FOR ILLUSTRATIONS, VEHICLE DETAILING THE LO AND IDENTIFICATION OF COMPONENTS, AND CONTROL MODULE PINS.

DATE OF ISSUE: JANUARY 1995

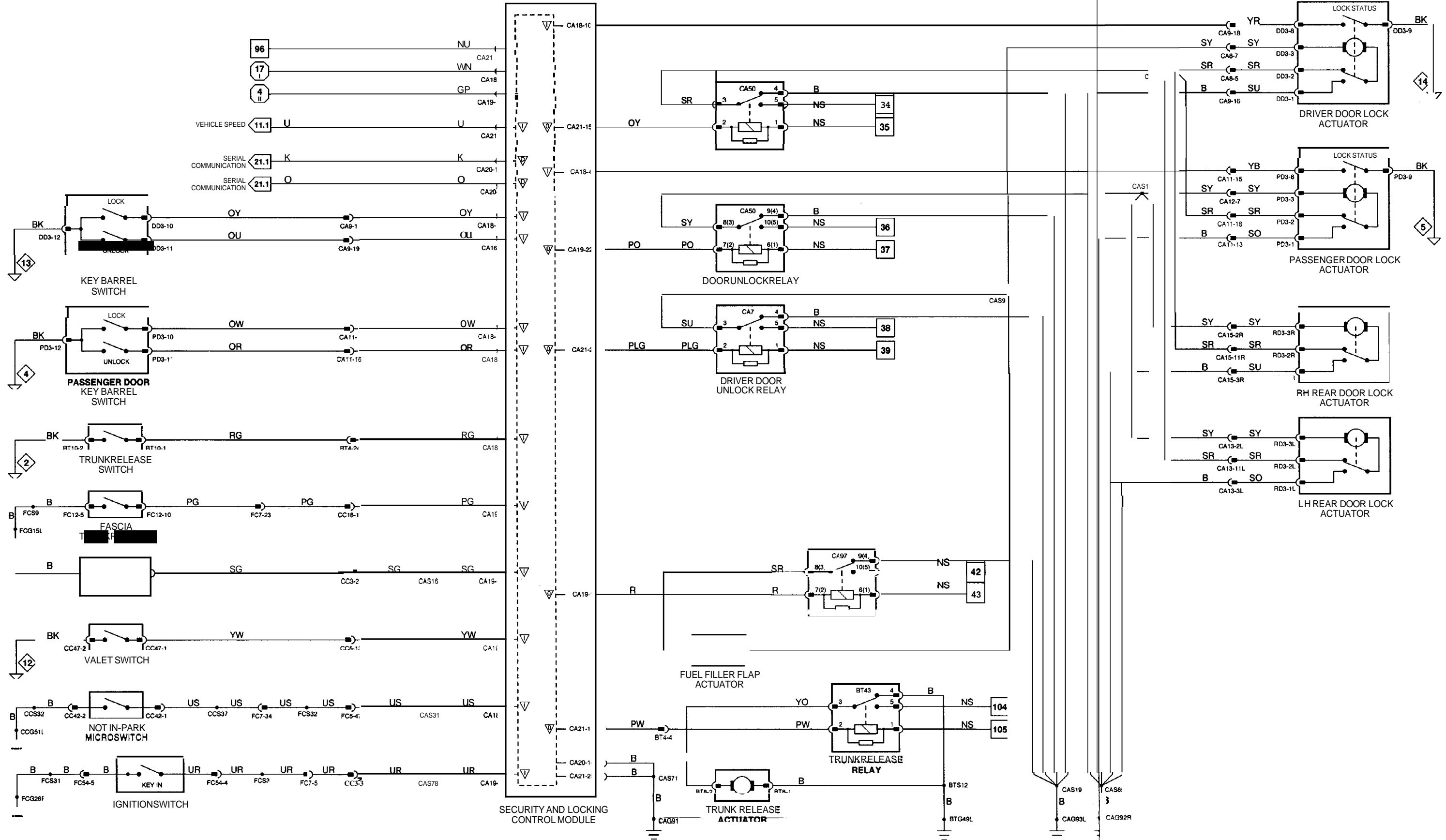

CONTROL MODULE PIN OUT INFORMATION

SECURITY AND LOCKING CONTROL MODULE

Pin	Description	Active	Inactive
I CA18-2	EXTERNAL TRUNK LID SWITCH	GROUND	1.74 V
I CA18-3	NOT IN PARK MICROSWITCH	GROUND	B+
I CA18-4	DRIVER DOOR LOCK STATUS	GROUND = LOCKED	1.74 V = UNLOCKED
I CA18-5	PASSENGER DOOR LOCK BARREL UNLOCK/ DISARM REQUEST	MOMENTARY GROUND	1.74 V
I CA18-6	DRIVER W O R LOCK BARREL UNLOCK DISARM REQUEST	MOMENTARY GROUND	1.74 V
I CA18-10	PASSENGER DOOR LOCK STATUS	GROUND = LOCKED	1.74 V = UNLOCKED
I CA18-11	PASSENGER DOOR LOCK BARREL LOCK/ ARM REQUEST	MOMENTARY GROUND	1.74 V
I CA18-12	DRIVER W O R LOCK BARREL LOCK / ARM REQUEST	MOMENTARY GROUND	1.74 V
O CA19-1	FUEL FILLER FLAP LOCK REQUEST	GROUND PULSE	B+
I CA19-6	VALET SWITCH	MOMENTARY GROUND	2 V
I CA19-8	FASCIA TRUNK RELEASE SWITCH	MOMENTARY GROUND	2.1 V
I CA19-18	KEY IN IGNITION SWITCH	GROUND	9.5 V
I CA19-19	CENTRAL LOCKING SWITCH ALL CLOSE REQUEST	GROUND	B+
O CA19-22	W O R UNLOCK RELAY	GROUND PULSE	B+
D CA20-8	SERIAL COMMUNICATION INPUT		
D CA20-16	SERIAL COMMUNICATION OUTPUT		
O CA21-1	RHF & LHR DOOR DEADLOCK RELAY (NOT NAS)	GROUND PULSE	B+
I CA21-5	VEHICLE SPEED INPUT	B+ @ 10 MPH = 20 Hz, 20 MPH = 40 Hz	
O CA21-11	TRUNK RELEASE RELAY	GROUND PULSE	B+
O CA21-14	LHF & RHR DOOR DEADLOCK RELAY	GROUND PULSE	B+
O CA21-15	DOOR LOCK RELAY	GROUND PULSE	B+

Fig. 15.3

COMPONENTS

Component	Connector ■Type / Color	Location ■Access
CENTER CONSOLE SWITCH PACK	CC1 / 18-WAY MULTILOCK 040 ■BLACK	CENTER CONSOLE
DOOR KEY BARREL SWITCH - DRIVER	DD3 113-WAY ECONOSEAL ■■■ LC / BLACK	DOOR CASING
DOOR KEY BARREL SWITCH - PASSENGER	PD3 113-WAY ECONOSEAL ■■■ LC ■BLACK	DOOR CASING
DOOR LOCK ACTUATOR - DRIVER	DD3 113-WAY ECONOSEAL ■■■ LC / BLACK	DOOR CASING
DOOR LOCK ACTUATOR - LH REAR	RD3-L / 6-WAY ECONOSEAL ■■■ LC / BLACK	DOOR CASING
DOOR LOCK ACTUATOR - PASSENGER	PD3 / 13-WAY ECONOSEAL ■■■ LC / BLACK	DOOR CASING
DOOR LOCK ACTUATOR - RH REAR	RDOR / 6-WAY ECONOSEAL ■■■ LC / BLACK	DOOR CASING
FASCIA TRUNK RELEASE SWITCH	FC12 / 16-WAY MULTILOCK 040 / BLUE	STEERING COLUMN/ DRIVER'S UNDERSCUTTLE
FUEL FILLER FLAP ACTUATOR	CA88 ■2-WAY LABINAL / NATURAL	TRUNK, LH FRONT TRUNK TRIM
IGNITION SWITCH	FC54 (FLY LEAD) 18-WAY MULTILOCK 070 / WHITE	STEERING COLUMN / COVER
NOT IN-PARK MICROSWITCH	CC42 (FLY LEAD) / 2-WAY MULTILOCK 040 / BLACK	'J' GATE ■CENTER CONSOLE
SECURITY AND LOCKING CONTROL MODULE	CA18 / 12-WAY MULTILOCK 47 / SLATE CA19 122-WAY MULTILOCK 47 / SLATE CA20 / 16-WAY MULTILOCK 47 / SLATE CA21 126-WAY MULTILOCK 47 ■SLATE	TRUNK, LH FRONT TRUNK TRIM
SHORTING LINK	CA43 / 6-WAY MULTILOCK 070 / YELLOW	REAR SEAT, LH SIDE ■UNDER
TRUNK RELEASE ACTUATOR	BT8 12-WAY LABINAL ■BROWN	TRUNK LID TRUNK LID TRIM
TRUNK RELEASE SWITCH	BT10 / 2-WAY MULTILOCK 040 / GREEN	TRUNK LID TRUNK LID TRIM
VALET SWITCH	CC47 12-WAY MULTILOCK 040 / BLACK	CENTER CONSOLE GLOVE BOX

RELAYS

Relay	Color ■Stripe	Connector ■Color	Location ■Access
DEADLOCK RELAY - DRIVER, LH REAR	VIOLET	CA56 / VIOLET	LH HEELBOARD
DEADLOCK RELAY - PASSENGER, RH REAR	VIOLET	CA55 / VIOLET	LH HEELBOARD
DOOR LOCK RELAY	VIOLET	CA50 / VIOLET	LH HEELBOARD
DOOR UNLOCK RELAY	VIOLET	CA50 ■VIOLET	LH HEELBOARD
FUEL FILLER FLAP RELAY	VIOLET	CA97 ■VIOLET	LH HEELBOARD
TRUNK RELEASE RELAY	BLACK ■VIOLET	BT43 / VIOLET	TRUNK ELECTRICAL CARRIER

HARNESSTO-HARNESCONNECTORS

Connector	Type ■Color	Location ■Access
BT4	THROUGH-PANEL (48 MICRO / 6) ■BLACK	PARCEL SHELF / FUEL TANK TRIM
CA8	20-WAY MULTILOCK 040 / GREEN	DRIVER'S UNDERSCUTTLE
CA9	20-WAY MULTILOCK 040 / BLACK	DRIVER'S 'A' POST / 'A' POST TRIM
CA11	20-WAY MULTILOCK 040 ■BLACK	PASSENGER'S UNDERSCUTTLE / ECM
CA12	12-WAY MULTILOCK 070 / WHITE	PASSENGER'S UNDERSCUTTLE / ECM
CA13	12-WAY MULTILOCK 040 / BLACK	LH 'B' POST / 'B' POST PANEL
CA15	12-WAY MULTILOCK 040 / BLACK	RH 'BC' POST ■BC POST PANEL
CC18	20-WAY MULTILOCK 040 / BLUE	CENTER CONSOLE ■CENTER CONSOLE
CC3	20-WAY MULTILOCK 040 / BLACK	CENTER CONSOLE 1 CENTER CONSOLE GLOVE BOX
CC5	20-WAY MULTILOCK 040 / GREEN	CENTER CONSOLE ■CENTER CONSOLE GLOVE BOX
FC5	THROUGH-PANEL (48 MICRO / 6) / BLACK	LH FASCIA END PANEL / WATER AIR VENT
FC7	THROUGH-PANEL (48 MICRO / 6) / BLACK	PASSENGER'S UNDERSCUTTLE

GROUNDS

Ground	Location ■Type
BTG49L	REAR TRUNK GROUND STUD
CAG91	PARCEL SHELF GROUND SCREW
CAG92R	RH HEELBOARD GROUND SCREW
CAG93L	LH HEELBOARD GROUND SCREW
CCG51L	CENTER CONSOLE GROUND STUD
FCG15L	LH CONSOLE GROUND STUD
FCG26R	LH CONSOLE GROUND STUD

CONTROL MODULE PIN OUT INFORMATION (FOLD OUT PAGE)



The following symbols are used to represent values for Control Module Pin Out data:

I	Input	B+	Battery voltage
O	Output	V	Voltage (DC)
SG	Signal Ground	Hz	Frequency
D	Serial and encoded communications	KHz	Frequency x 1000
		MS	Milliseconds
		MV	Millivolts

CAUTION: The information on this data page is furnished to aid the user in understanding circuit operation. THIS INFORMATION SHOULD BE USED FOR REFERENCE ONLY.

NOTE: The values listed are approximately those that can be expected at the control module connector pins with all circuit connections made and all components connected and fitted. "Active" means a load is applied or a switch is ON; "Inactive" means a load is not applied or a switch is OFF.

REFER TO THE FRONT OF THE BOOK FOR ILLUSTRATIONS DETAILING THE LOCATION AND IDENTIFICATION OF COMPONENTS, RELAYS, CONNECTORS, HARNESSES, GROUNDS, VEHICLE CONTROL MODULES AND CONTROL MODULE PINS.

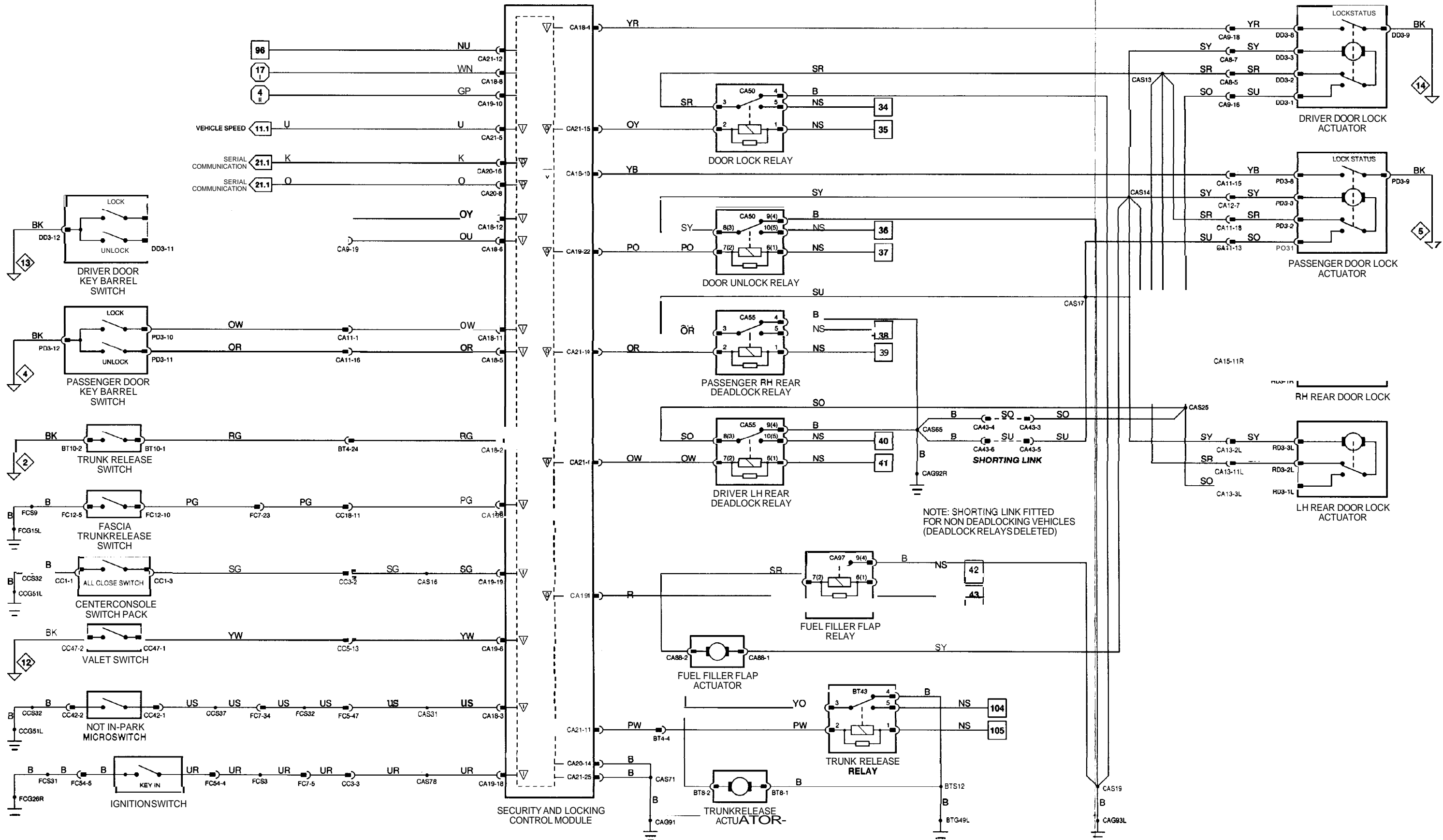

**CONTROL MODULE PIN OUT INFORMATION**

**BODY PROCESSOR MODULE**

Pin	Description	Active	Inactive
O FC1-14	LH PILOT BEAM, SIDE LAMPS AND TAIL LAMPS ON	GROUND	B+
O FC1-16	REAR WINDOW RAISE	GROUND	B+
O FC1-24	INTERIOR AND COURTESY LAMPS	GROUND	B+
O FC1-29	LH DIPPED BEAM ON	GROUND	B+
O FC1-31	FRONT PASSENGER WINDOW RAISE	GROUND	B+
O FC1-33	STARTER RELAY INHIBIT	GROUND	B+
O FC1-35	LH MAIN BEAM ON	GROUND	B+
O FC1-36	SLIDING ROOF CLDSE	GROUND	B+
O FC1-37	DRIVER WINDOW RAISE	GROUND	B+
O FC1-39	RH DIPPED BEAM ON	GROUND	B+
O FC1-41	RH MAIN BEAM ON	GROUND	B+
I FC2-2	INTERIOR LAMPS ON	GROUND	B+
D FC2-5	SECURE STATUS INPUT FROM SECURITY AND LOCKING CONTROL MODULE	ENCODED COMMUNICATIONS	
I FC2-6	HEADLAMP CONVENIENCE	GROUND PULSE	B+
I FC2-26	SECURITY SYSTEM VISUAL WARNING	GROUND PULSE	B+
I FC2-28	REMOTE ALL CLOSE REQUEST	GROUND	B+

**SECURITY AND LOCKING CONTROL MODULE**

Pin	Description	Active	Inactive
I CA18-1	PASSENGER DOOR WAR	GROUND	1.74 V
I CA18-4	PASSENGER W/O R LOCK STATUS	GROUND - LOCKED	1.74 V = UNLOCKED
I CA18-7	DRIVER DOOR AJAR	GROUND	7.9 V
D CA18-9	TRANSPONDER IMMOBILIZATION OUTPUT (NOT NAS)	ENCODED COMMUNICATIONS	
I CA18-10	DRIVER DOOR LOCK STATUS	GROUND - LOCKED	1.74 V = UNLOCKED
I CA19-6	VALET SWITCH	MOMENTARY GROUND	2 V
I CA19-7	INCLINATION SENSOR VIOLATION	GROUND PULSE	1.3 V
I CA19-9	HOOD AJAR	GROUND	1.7 V
D CA19-11	TRANSPONDER IMMOBILIZATION ON OUTPUT (NOT NAS)	ENCODED COMMUNICATIONS	
O CA19-12	MEMORY SEAT REMOTE INDICATOR	GROUND PULSE	B+
O CA19-13	HEADLAMP CONVENIENCE	GROUND PULSE	7.89 V
I CA19-19	CENTRAL LOCKING SWITCH ALL CLOSE REQUEST	GROUND	B+
I CA19-20	TRUNK LID WAR	GROUND	7.9 V
I CA19-21	REAR PASSENGER W/O R AJAR	GROUND	7.9 V
I CA20-4	RH INTRUSION SENSOR (NOT NAS)	SIGNAL	GROUND
O CA20-5	RH INTRUSION SENSOR VOLTAGE FEED (NOT NAS)	8 V	GROUND
O CA20-6	READER EXCITER CONTROL MODULE GROUND (NOT NAS)	GROUND	GROUND
D C M - 8	SERIAL COMMUNICATION INPUT		
I C M - 12	LH INTRUSION SENSOR (NOT NAS)	SIGNAL	GROUND
O CA20-13	LH INTRUSION SENSOR VOLTAGE FEED (NOT NAS)	8 V	GROUND
D CA20-16	SERIAL COMMUNICATION OUTPUT		
O CA21-6	INCLINATION SENSOR GROUND	GROUND	GROUND
D CA21-7	INTELLIGENT SOUNDER OUTPUT	ENCODED COMMUNICATIONS	
O CA21-8	MEMORY POSITION 2 REQUEST	B+ WLSE	GROUND
O CA21-9	VISUAL WARNING	GROUND WLSE	B+
D CA21-10	SECURE STATUS OUTPUT TO BODY PROCESSOR	ENCODED COMMUNICATIONS	
O CA21-19	SECURITY ACTIVE LED	9V PULSE	GROUND
D CA21-20	FUELING INHIBIT SIGNAL OUTPUT (NOT NAS)	ENCODED COMMUNICATIONS	
O CA21-21	MEMORY POSITION 1 REQUEST	B+ PULSE	GROUND
O CA21-22	ALL CLOSE REQUEST	GROUND	7.6 V
O CA21-23	INTERIOR LIGHTS ON	GROUND PULSE	7.8 V
O CA21-24	HORN	GROUND PULSE	B+

The following symbols are used to represent values for Control Module Pin Out data

I	Input	B+	Battery voltage
O	Output	V	Voltage (DC)
SG	Signal Ground	Hz	Frequency
D	Serial and encoded communications	KHz	Frequency x 1000
		MS	Milliseconds
		MV	Millivolts

**CAUTION:** The information on this data page is furnished to aid the user in understanding circuit operation. THIS INFORMATION SHOULD BE USED FOR REFERENCE ONLY.

**NOTE:** The values listed are approximately those that can be expected at the control module connector pins with all circuit connections made and all components connected and fitted. "Active" means a load is applied or a switch is ON; "Inactive" means a load is not applied or a switch is OFF.

**Fig. 15.4**

**COMPONENTS**

Component	Connector / Type / Color	Location / Access
BODY PROCESSOR MODULE	FC1 / 48-WAY PCB SIGNAL / YELLOW FC2 / 48-WAY PCB SIGNAL / BLACK FC3 / 6-WAY PCB SIGNAL / BLACK	PASSENGER'S UNDERSCUTTLE
CENTER CONSOLE SWITCHPACK COIL (COLUMN SWITCHGEAR) DOOR LOCK ACTUATOR - DRIVER DOOR LOCK ACTUATOR - PASSENGER DOOR SWITCH PACK - DRIVER	CC1 / 16-WAY MULTILOCK 040 / BLACK SC11 / 12-WAY MULTILOCK 040 / GREEN DD3 / 13-WAY ECONOSEAL III LC / BLACK PD3 / 13-WAY ECONOSEAL III LC / BLACK DD1 / 12-WAY MULTILOCK 47 / WHITE DD2 / 22-WAY MULTILOCK 47 / WHITE	CENTER CONSOLE STEERING COLUMN COVER DOOR CASING W/O R CASING ARM REST / TOP ROLL
DOOR SWITCH PACK - LH REAR DOOR SWITCH PACK - PASSENGER DOOR SWITCH PACK - RH REAR W/O R SWITCH - DRIVER DOOR SWITCH - LH REAR DOOR SWITCH - PASSENGER DOOR SWITCH - RH REAR	RD1-L / 12-WAY MULTILOCK 070 / WHITE PD1 / 26-WAY MULTILOCK 47 / SLATE RD1-R / 12-WAY MULTILOCK 070 / WHITE DD3 / 13-WAY ECONOSEAL III LC / BLACK RD3-L / 13-WAY ECONOSEAL III LC / BLACK PD3 / 13-WAY ECONOSEAL III LC / BLACK RD3-R / 13-WAY ECONOSEAL III LC / BLACK	DOOR CASING DOOR CASING DOOR CASING DOOR CASING DOOR CASING DOOR CASING DOOR CASING
HOODSWITCH INCLINATION SENSOR INTRUSION SENSOR - LH INTRUSION SENSOR - RH READER EXCITER CONTROL MODULE SECURITY AND LOCKING CONTROL MODULE	RS17 / 2-WAY ECONOSEAL III LC / BLACK CA66 / 6-WAY CS-251 ORANGE RF6 / 4-WAY MODU / BLACK RF5 / 4-WAY MODU / BLACK FC53 / 20-WAY MULTILOCK 040 / BLACK CA18 / 12-WAY MULTILOCK 47 / SLATE CA19 / 122-WAY MULTILOCK 47 / SLATE CA20 / 16-WAY MULTILOCK 47 / SLATE CA21 / 26-WAY MULTILOCK 47 / SLATE CA26 / 12-WAY MULTILOCK 47 / SLATE	ENGINE BAY, RH FRONT TRUNK, LH FRONT / TRUNK TRIM HEADLINER, LH SIDE HEADLINER, RH SIDE DRIVER'S UNDERSCUTTLE TRUNK, LH FRONT / TRUNK TRIM
SECURITY ANTENNA SECURITY SOUNDER TRUNK SWITCH VALET SWITCH	RS21 (FLY LEAD) / 6-WAY ECONOSEAL III LC / BLACK BT15 / 2-WAY FORD DIAGNOSTIC / BLACK CC47 / 2-WAY MULTILOCK 040 / BLACK	BACKLIGHT ENGINE BAY, RH FRONT TRUNK LID / TRUNK LID TRIM CENTER CONSOLE GLOVE BOX

**HARNESS-TO-HARNESS CONNECTORS**

Connector	Type / Color	Location / Access
BT4	THROUGH-PANEL (48 MICRO / 6) / BLACK	PARCEL SHELF / FUEL TANK TRIM
CA8	20-WAY MULTILOCK 040 / GREEN	DRIVER'S UNDERSCUTTLE
CA9	20-WAY MULTILOCK 040 / BLACK	DRIVERS' A' POST / A' POST TRIM
CA10	8-WAY MULTILOCK 070 / WHITE	DRIVER'S UNDERSCUTTLE
CA11	20-WAY MULTILOCK 040 / BLACK	PASSENGER'S UNDERSCUTTLE / ECM
CA12	12-WAY MULTILOCK 070 / WHITE	PASSENGER'S UNDERSCUTTLE / ECM
CA13	12-WAY MULTILOCK 040 / BLACK	LH 'BC' POST / 'BC' POST PANEL
CA14	2-WAY MULTILOCK 070 / WHITE	RH 'BC' POST / 'BC' POST PANEL
CA15	12-WAY MULTILOCK 040 / BLACK	RH 'BC' POST / 'BC' POST PANEL
CA16	2-WAY MULTILOCK 070 / WHITE	RH 'BC' POST / 'BC' POST PANEL
CC3	20-WAY MULTILOCK 040 / BLACK	CENTER CONSOLE / CENTER CONSOLE GLOVE BOX
CC5	20-WAY MULTILOCK 040 / GREEN	CENTER CONSOLE / CENTER CONSOLE GLOVE BOX
FC5	THROUGH-PANEL (48 MICRO / 6) / BLACK	LH FASCIA END PANEL / OUTER AIR VENT
FC7	THROUGH-PANEL (48 MICRO / 6) / BLACK	PASSENGER'S UNDERSCUTTLE
FC8	12-WAY MULTILOCK 040 / BLACK	DRIVER'S UNDERSCUTTLE
FC16	20-WAY MULTILOCK 040 / BLACK	PASSENGER'S UNDERSCUTTLE
P11	13-WAY ECONOSEAL III LC / WHITE	RH AIR CLEANER
RF4	12-WAY MULTILOCK 040 / BLACK	ROOF CONSOLE
RS3	THROUGH-PANEL (48 MICRO / 6) / BROWN	RH 'A' POST / 'A' POST PANEL

**GROUNDS**

Ground	Location / Type
CAG30L	LH 'A' POST GROUND SCREW
CAG33L	RH HEELBOARD GROUND SCREW
CAG49	RH CONSOLE GROUND STUD
CAG91	PARCEL SHELF GROUND SCREW
CAG92L	RH HEELBOARD GROUND SCREW
CAG93R	LH HEELBOARD GROUND SCREW
CCG51L	CENTER CONSOLE GROUND STUD
FCG15L	LH CONSOLE GROUND STUD
RS41L	RIGHT FORWARD GROUND STUD
RS6L	RIGHT FORWARD GROUND STUD

**CONTROL MODULE PIN OUT INFORMATION (FOLD OUT PAGE)**



REFER TO THE FRONT OF THE BODY RELAYS, CONNECTOR HARNESS FOR IDENTIFICATIONS DETAILING THE LOCATION AND IDENTIFICATION OF COMPONENTS, GROUPINGS, VEHICLE CONTROL MODULES AND CONTROL MODULE PINS.

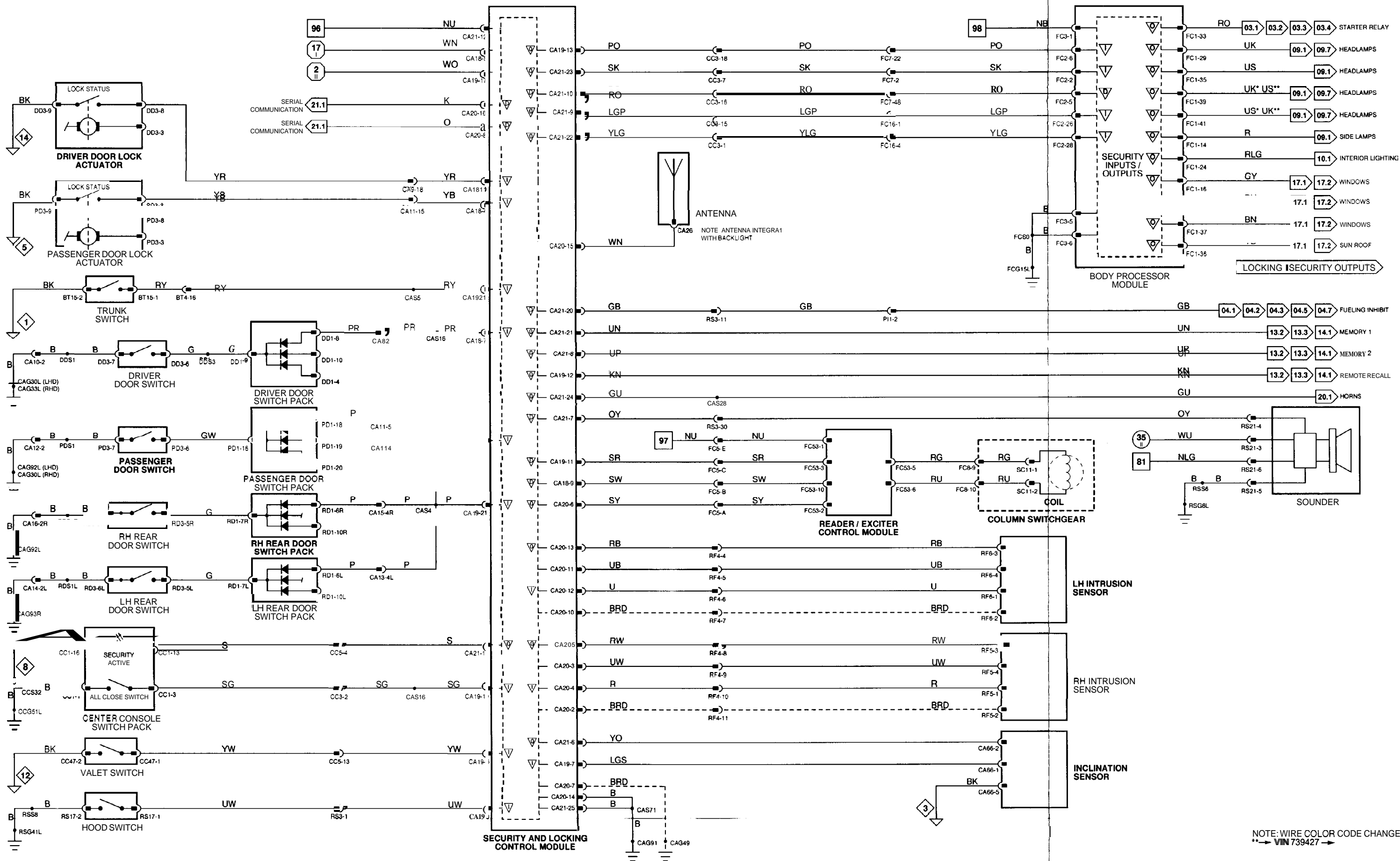

NOTE: WIRE COLOR CODE CHANGE \*\* -> VIN 739427 ->

**CONTROL MODULE PIN OUT INFORMATION**

**BODY PROCESSOR MODULE**

Pin	Description	Active	Inactive
O FC1-14	LHPILOT BEAM, SIDE LAMPS AND TAIL LAMPS ON	GROUND	B+
O FC1-16	REAR WINDOW RAISE	GRDUNO	B+
O FC1-24	INTERIOR AND COURTESY LAMPS	GROUND	B+
O FC1-29	LH DIPPED BEAM ON	GROUND	B+
O FC1-31	FRONT PASSENGER WINDOW RAISE	GROUND	B+
O FC1-33	STARTER RELAY INHIBIT	GROUND	B+
O FC1-35	LH MAIN BEAM ON	GROUND	B+
O FC1-36	SLIDING ROOF CLOSE	GROUND	B+
O FC1 31	DRIVER WINDOW RAISE	GROUND	B+
O FC1-39	RH DIPPED BEAM ON	GROUND	B+
O FC1 41	RH MAIN BEAM ON	GROUND	B+
I FC22	INTERIOR LAMPS ON	GROUND	B+
D FC2-5	SECURE STATUS INPUT FROM SECURITY AND LOCKING CONTROL MODULE	ENCODED COMMUNICATIONS	B+
I FC2-6	HEADLAMP CONVENIENCE	GROUND PULSE	B+
I FC2-26	SECURITY SYSTEM VISUAL WARNING	GROUND PULSE	B+
I FC2-28	REMOTE ALL CLOSE REQUEST	GROUND	B+

**SECURITY AND LOCKING CONTROL MODULE**

Pin	Description	Active	Inactive
I CA18-1	PASSENGER W O R AJAR	GROUND	1.74 V
I CA18-4	PASSENGER DOOR LOCK STATUS	GROUND - LOCKED	1.74 V = UNLOCKED
I CA187	DRIVER DOOR AJAR	GROUND	7.9 V
I CA18-10	DRIVER DOOR LOCK STATUS	GROUND - LOCKED	1.74 V = UNLOCKED
I CA19-6	VALET SWITCH	MOMENTARY GROUND	2 V
I CA19-7	INCLINATION SENSOR VIOLATION	GROUND PULSE	1.3 V
I CA19-9	HOOD AJAR	GROUND	1.7 V
O CA19-12	MEMORY SEAT REMOTE INDICATOR	GROUND PULSE	B+
O CA19-13	HEADLAMP CONVENIENCE	GROUND PULSE	7.89 V
I CA19-19	CENTRAL LOCKING SWITCH ALL CLOSE REQUEST	GROUND	B+
I CA19-20	TRUNK LID AJAR	GROUND	7.9 v
I CA19-21	REAR PASSENGER DOOR AJAR	GROUND	7.9 v
CA20-4	RH INTRUSION SENSOR (NOT NASI)	SIGNAL	GROUND
O CA20-5	RH INTRUSION SENSOR VOLTAGE FEED (NOT NASI)	8 V	GROUND
D CA20-8	SERIAL COMMUNICATION INPUT		
I CA20-12	LH INTRUSION SENSOR (NOT NASI)	SIGNAL	GROUND
O CA20-13	LH INTRUSION SENSOR VOLTAGE FEED (NOT NASI)	8 V	GROUND
D CA20-16	SERIAL COMMUNICATION OUTPUT		
O CA21-6	INCLINATION SENSOR GROUND	GROUND	GROUND
O CA21-6	MEMORY POSITION 2 REQUEST	B+ PULSE	GROUND
O CA21-9	VISUAL WARNING	GROUND PULSE	B+
D CA21-10	SECURE STATUS OUTPUT TO BODY PROCESSOR	ENCODED COMMUNICATIONS	
O CA21-13	SECURITY SOUNDER	5 V (480 - 1900 Hz)	GROUND
O CA21-19	SECURITY ACTIVE LED	9V PULSE	GROUND
D CA21-20	FUELING INHIBIT SIGNAL OUTPUT (NOT NASI)	ENCODED COMMUNICATIONS	
O CA21-21	MEMORY POSITION 1 REQUEST	B+ PULSE	GROUND
O CA21-22	ALL CLOSE REQUEST	GROUND	7.8 V
O CA21-23	INTERIOR LIGHTS ON	GROUND PULSE	7.8 V
O CA21-24	HORN	GROUND PULSE	B+
O CA21-26	SECURITY SOUNDER	5 V 1480 ~ 1900Hz)	GROUND

The following symbols are used to represent values for Control Module Pin Out data:

I	Input	B+	Battery voltage
O	output	V	Voltage (DC)
SG	Signal Ground	Hz	Frequency
D	Serial and encoded communications	KHz	Frequency x 1000
		MS	Milliseconds
		MV	Millivolts

**CAUTION:** The information on this data page is furnished to aid the user in understanding circuit operation. THIS INFORMATION SHOULD BE USED FOR REFERENCE ONLY.

**NOTE:** The values listed are approximately those that can be expected at the control module connector pins with all circuit connections made and all components connected and fitted. "Active" means a load is applied or a switch is ON; "Inactive" means a load is not applied or a switch is OFF.

**Fig. 15.5**

**COMPONENTS**

Component	Connector / Type / Color	Location / Access
BODY PROCESSOR MODULE	FC1 / 48-WAY PCB SIGNAL / YELLOW FC2 / 48-WAY PCB SIGNAL / BLACK FC3 / 6-WAY PCB SIGNAL / BLACK	PASSENGER'S UNDERSCUTTLE
CENTER CONSOLE SWITCH PACK	CC1 116-WAY MULTILOCK 0401 / BLACK	CENTER CONSOLE
DOOR LOCK ACTUATOR - DRIVER	DD3 / 13-WAY ECONOSEAL III LC / BLACK	DOOR CASING
DOOR LOCK ACTUATOR - PASSENGER	PD3 / 13-WAY ECONOSEAL III LC / BLACK	DOOR CASING
DOOR SWITCH PACK - DRIVER	DD1 / 12-WAY MULTILOCK 47 / WHITE DD2 122-WAY MULTILOCK 47 / WHITE	ARM REST / TOP ROLL
DOOR SWITCH PACK - LH REAR	RD1-L / 12-WAY MULTILOCK 070 / WHITE	DOOR CASING
DOOR SWITCH PACK - PASSENGER	PO1 126-WAY MULTILOCK 47 / SLATE	ARM REST / TOP ROLL
DOOR SWITCH - RH REAR	RD1-R 112-WAY MULTILOCK 0701 / WHITE	DOOR CASING
DOOR SWITCH - DRIVER	DD3 / 13-WAY ECONOSEAL III LC / BLACK	DOOR CASING
DOOR SWITCH - LH REAR	RD3-L / 6-WAY ECONOSEAL III LC / BLACK	DOOR CASING
DOOR SWITCH - PASSENGER	PD3 / 13-WAY ECONOSEAL III LC / BLACK	DOOR CASING
DOOR SWITCH - RH REAR	RD3-R 16-WAY ECONOSEAL III LC / BLACK	DOOR CASING
HOOD SWITCH	RS17 12-WAY ECONOSEAL III LC / BLACK	ENGINE BAY, RH FRONT
INCLINATION SENSOR	CA86 / 6-WAY CS-25 / ORANGE	TRUNK, LH FRONT / TRUNK TRIM
INTRUSION SENSOR - LH	RF6 / 4-WAY MODU / BLACK	HEAD LINER, LH SIDE
INTRUSION SENSOR - RH	RF5 / 4-WAY MODU / BLACK	HEAD LINER, RH SIDE
SECURITY AND LOCKING CONTROL MODULE	CA18 112-WAY MULTILOCK 47 / SLATE CA19 122-WAY MULTILOCK 47 / SLATE CA20 116-WAY MULTILOCK 47 / SLATE CA21 / 26-WAY MULTILOCK 47 / SLATE CA26 / LUCAR / BLACK	TRUNK, LH FRONT / TRUNK TRIM
SECURITY ANTENNA	CA26 / LUCAR / BLACK	BACKLIGHT
SECURITY SOUNDER	RS21 (FLY LEAD) / 6-WAY ECONOSEAL III LC / BLACK	ENGINE BAY, RH FRONT
TRUNK SWITCH	BT15 / 2-WAY FORD DIAGNOSTIC / BLACK	TRUNK LID / TRUNK LID TRIM
VALET SWITCH	CC47 12-WAY MULTILOCK 040 / BLACK	CENTER CONSOLE GLOVE BOX

**HARNESSTO-HARNESSTO CONNECTORS**

Connector	Type / Color	Location / Access
BT4	THROUGH-PANEL (48 MICRO / 6) / BLACK	PARCEL SHELF / FUEL TANK TRIM
CA8	20-WAY MULTILOCK 040 / GREEN	DRIVER'S UNDERSCUTTLE
CA9	20-WAY MULTILOCK 040 / BLACK	DRIVER'S 'A' POST / 'A' POST TRIM
CA10	8-WAY MULTILOCK 070 / WHITE	DRIVER'S UNDERSCUTTLE
CA11	20-WAY MULTILOCK MO / BLACK	PASSENGERS UNDERSCUTTLE / ECM
CA12	12-WAY MULTILOCK 070 / WHITE	PASSENGERS UNDERSCUTTLE / ECM
CA13	12-WAY MULTILOCK 040 / BLACK	LH 'BC' POST / 'BC' POST PANEL
CA14	2-WAY MULTILOCK 070 / WHITE	LH 'BC' POST / 'BC' POST PANEL
CA15	12-WAY MULTILOCK 040 / BLACK	RH 'BC' POST / 'BC' POST PANEL
CA16	2-WAY MULTILOCK 0701 / WHITE	RH 'BC' POST / 'BC' POST PANEL
CC3	20-WAY MULTILOCK 040 / BLACK	CENTER CONSOLE / CENTER CONSOLE GLOVE BOX
CC5	20-WAY MULTILOCK 040 / GREEN	CENTER CONSOLE / CENTER CONSOLE GLOVE BOX
FC7	THROUGH-PANEL (48 MICRO / 6) / BLACK	PASSENGERS UNDERSCUTTLE
FC16	20-WAY MULTILOCK 040 / BLACK	PASSENGERS UNDERSCUTTLE
PI1	13-WAY ECONOSEAL III LC / WHITE	RH AIR CLEANER
RF4	12-WAY MULTILOCK 040 / BLACK	ROOF CONSOLE
RS3	THROUGH-PANEL (48 MICRO / 6) / BROWN	RH 'A' POST / 'A' POST PANEL

**GROUNDS**

Ground	Location / Type
CAG30L	LH 'A' POST GROUND SCREW
CAG49	RH CONSOLE GROUND STUD
CAG91	PARCEL SHELF GROUND SCREW
CAG92L	RH HEELBOARD GROUND SCREW
CAG93R	LH HEELBOARD GROUND SCREW
CCG51L	CENTER CONSOLE GROUND STUD
FCG15L	LH CONSOLE GROUND STUD
RS41L	RIGHT FORWARD GROUND STUD

**CONTROL MODULE PIN OUT INFORMATION (FOLD OUT PAGE)**



REFER TO THE FRONT OF THE BOOK FOR ILLUSTRATIONS DETAILING THE LOCATION AND IDENTIFICATION OF COMPONENTS, RELAYS, CONNECTORS, GROUNDS, VEHICLE CONTROL MODULES AND CONTROL MODULE PINS.



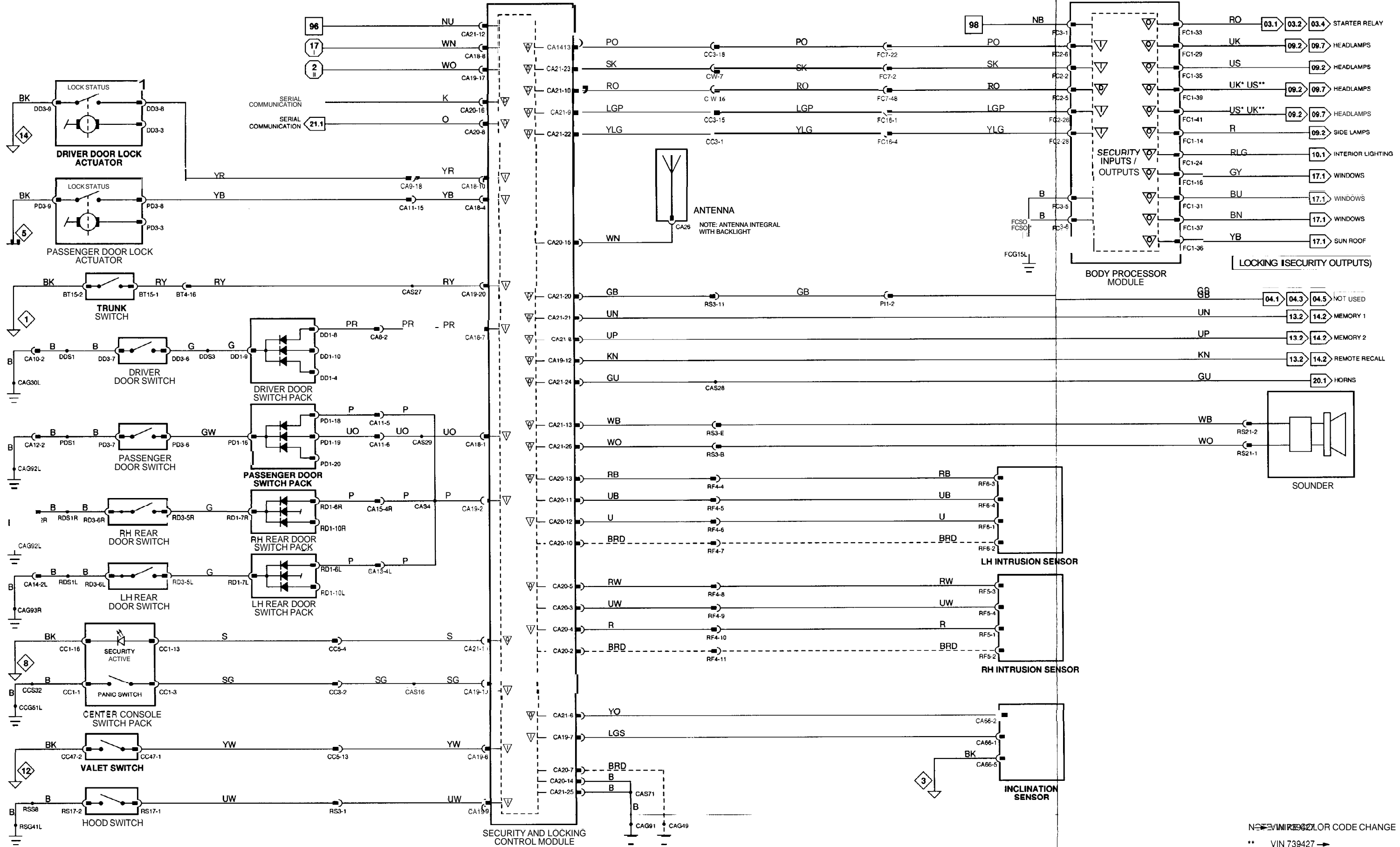

NOTE: VIN 1992  
 \*\* VIN 739427 →

CONTROL MODULE PIN OUT INFORMATION

BODY PROCESSOR MODULE

Pin	Description	Active	Inactive
O FC1-27	WIPER RELAY	GROUND	B+
O FC1-34	WINDSHIELD WASH PUMP RELAY	GROUND	B+
O FC1-40	HEADLAMP POWER WASH PUMP RELAY	GROUND	B+
I FC2-1	WIPER MOTOR PARK SWITCH	GROUND	B+
I FC2-3	SIDE LAMPS ON	GROUND	B+
I FC2-4	VEHICLE SPEED SENSOR	GROUND PULSE @ 10 MPH 116 KPHI ■ 20 Hz, 20 MPH (32 KPHI ■ 40 Hz	B+
I FC2-14	WASH (PRE PROGRAMMED)	GROUND	B+
I FC2-22	WASHER FLUID LEVEL	GROUND	B+
I FC2-31	IGNITION SWITCHED GROUND	GROUND	B+
I FC2-39	WIPER DELAY	GROUND	B+
I FC2-47	SLOW / FLICK WIPER	GROUND	B+

**Fig. 16.1**

COMPONENTS

Component	Connector   Type   Color	Location / Access
AMBIENT TEMPERATURE SWITCH BODY PROCESSOR MODULE	BR7 12-WAY ECONOSEAL III LC / WHITE FC1 / 48-WAY PCB SIGNAL I YELLOW FC2 / 48-WAY PCB SIGNAL I BLACK FC3 / 6-WAY PCB SIGNAL I BLACK	LH FRONT WHEEL ARCH LINER / SPOILER TRAY PASSENGERS UNDERSCUTTLE
DIODE (FC58) - WASH / WIPE SWITCH	FC58 / DIODE / BLACK	FASCIA HARNESS / PASSENGER AIR BAG (PASSENGER SIDE FASCIATRIM)
DIODE (FC61) - WASH / WIPE SWITCH	FC61 / DIODE / BLACK	FASCIA HARNESS / PASSENGER AIR BAG (PASSENGER SIDE FASCIATRIM)
LIGHTING SWITCHES POWER WASH PUMP WASH / WIPE SWITCHES (COLUMN SWITCHGEARJ WASHER FLUID LEVEL SWITCH WINDSHIELD WASH HEATER - LH WINDSHIELD WASH HEATER - RH WINDSHIELD WASH PUMP WIPER MOTOR	FC12 / 16-WAY MULTILOCK 040 / BLUE RS26 / 2 WAY ECONOSEAL III HC / RED SC2 / 6-WAY MULTILOCK 070 / WHITE RS18 / 2 WAY ECONOSEAL III LC / RED PI71 12-WAY SUMITOMO 90 / WHITE PI72 12-WAY SUMITOMO 90 / WHITE RS25 / 2-WAY ECONOSEAL III LC / BLACK LS9 / 6-WAY ECONOSEAL III LC / BLACK	FASCIA SWITCH PACK ENGINE BAY, RH INNER FENDER STEERING COLUMN / COVER WASHER FLUID RESERVOIR PLENUM CHAMBER / COVER PLENUM CHAMBER / COVER WASHER FLUID RESERVOIR PLENUM CHAMBER / COVER

RELAYS

Relay	Color / Stripe	Connector / Color	Location / Access
POWER WASH PUMP RELAY	BLACK / WHITE	RS20 / BLACK	RH ENGINE BAY RELAYS
WINDSHIELD WASH PUMP RELAY	BLACK	RS2 / BLACK	RH ENGINE BAY RELAYS
WIPER FAST / SLOW RELAY	BLACK	LS49 / BLACK	LH ENGINE BAY RELAYS
WIPER ON / OFF RELAY	BLACK	LS48 / BLACK	LH ENGINE BAY RELAYS

HARNESS-TO-HARNESS CONNECTORS

Connector	Type / Color	Location / Access
BR1	13-WAY ECONOSEAL III LC / BLACK	RH FRONT WHEEL ARCH LINER / SPOILER AND SPOILER TRAY
FC5	THROUGH-PANEL 148 MICRO / 61 / BLACK	LH FASCIA END PANEL / OUTER AIR VENT
FC6	THROUGH-PANEL 148 MICRO / 61 / BLACK	RH FASCIA END PANEL / OUTER AIR VENT
FC8	12-WAY MULTILOCK 040 / BLACK	DRIVER'S UNDERSCUTTLE
FC16	20-WAY MULTILOCK 040 / BLACK	PASSENGERS UNDERSCUTTLE
LS3	THROUGH-PANEL 148 MICRO / 61 / BLACK	LH 'A' POST / 'A' POST PANEL
PI61	13-WAY ECONOSEAL III LC / BLACK	RH AIR CLEANER
RS3	THROUGH-PANEL 148 MICRO / 61 / BROWN	RH 'A' POST / 'A' POST PANEL

GROUNDS

Ground	Location / Type
FCG15L	LH CONSOLE GROUND STUD
FCG26R	LH CONSOLE GROUND STUD
LSG19L	LH BULKHEAD GROUND STUD
LSG19R	LH BULKHEAD GROUND STUD
LSG52R	LEFT FORWARD GROUND STUD
PIG154R	LEFT FORWARD GROUND STUD
PIG77R	RIGHT FORWARD EMS GROUND STUD
RSG41L	RIGHT FORWARD GROUND STUD
RSG8L	RIGHT FORWARD GROUND STUD

CONTROL MODULE PIN OUT INFORMATION (FOLD OUT PAGE)



The following symbols are used to represent values for Control Module Pin Out data:

I Input	B+ Battery voltage
O Output	V Voltage (DC)
SG Signal Ground	Hz Frequency
D Serial and encoded communications	KHz Frequency x 1000
	MS Milliseconds
	MV Millivolts

CAUTION: The information on this data page is furnished to aid the user in understanding circuit operation. THIS INFORMATION SHOULD BE USED FOR REFERENCE ONLY.

NOTE: The values listed are approximately those that can be expected at the control module connector pins with all circuit connections made and all components connected and fitted. "Active" means a load is applied or a switch is ON; "Inactive" means a load is not applied or a switch is OFF.

REFER TO THE FRONT OF THE BOOK FOR ILLUSTRATIONS DETAILING THE LOCATION AND IDENTIFICATION OF COMPONENTS, RELAYS, CONNECTORS, HARNESSES, GROUNDS, VEHICLE CONTROL MODULES AND CONTROL MODULE PINS.

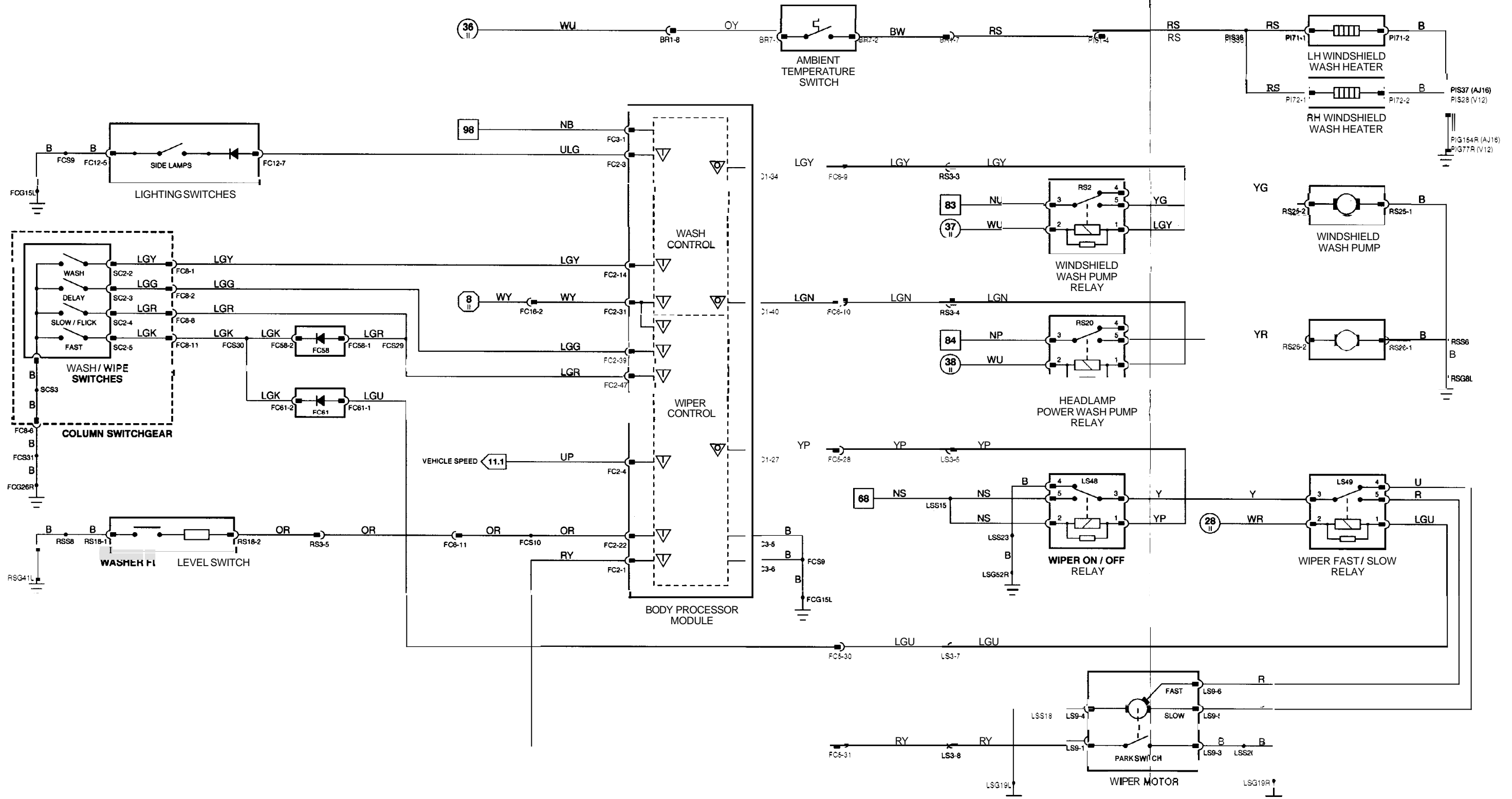

CONTROL MODULE PIN OUT INFORMATION

BODY PROCESSOR MODULE

Pin	Description	Active	Inactive
O FCI-16	REAR WINDOW RAISE	GROUND	B+
O FCI-31	FRONT PASSENGER WINDOW RAISE	GROUND	B+
O FCI-36	SLIDING ROOF CLOSE	GRDUNO	B+
O FCI-37	DRIVER WINDOW RAISE	GROUND	B+
I FC2-28	REMOTE ALL CLOSE REQUEST	GROUND	B+

SLIDING ROOF CONTROL MODULE

Pin	Description	Active	Inactive
I CAM-2	ALL CLOSE REQUEST	GROUND	B+
I CA84-4	ALL CLOSE REDUEST TO BM	GROUND	B+
I CAS-5	TILT OPEN / SLIDE CLOSE REQUEST	GROUND	B+
I CAS-6	TILT CLOSE / SLIDE OPEN REQUEST	GROUND	B+
O SR1-1	SLIDING ROOF MOTOR	B+	GROUND
O SR1-3	SLIDING ROOF MOTOR	B+	GROUND

Fig. 17.1

COMPONENTS

Component	Connector / Type / Color	Location / Access
BODY PROCESSOR MODULE	FC1 / 48-WAY PCB SIGNAL / YELLOW FC2 / 48-WAY PCB SIGNAL / BLACK FC3 / 8-WAY PCB SIGNAL / BLACK	PASSENGERS UNDERSCUTTLE
CENTER CONSOLE SWITCH PACK W/O R SWITCH PACK - DRIVER	CC1 / 15-WAY MULTILOCK 040 / BLACK DD1 / 12-WAY MULTILOCK 41 / WHITE DD2 / 22-WAY MULTILOCK 47 / WHITE	CENTER CONSOLE ARM REST/TOP ROLL
SLIDING ROOF CONTROL MODULE	CA84 / 6-WAY MULTILOCK 070 / WHITE SR1 / 6-WAY MULTILOCK 070 / WHITE	ROOF CONSOLE
SLIDING ROOF MOTOR	SR1 / 3-WAY MULTILOCK 070 / WHITE	ROOF CONSOLE
SLIDING ROOF SWITCH	CA83 / 8-WAY MULTILOCK 040 / BLACK	ROOF CONSOLE
WINDOW LIFT MOTOR - DRIVER	DD5 / 12-WAY ECONOSEAL III LC / BLACK	DRIVER'S DOOR / DOOR CASING
WINDOW LIFT MOTOR - LH REAR	RDCL / 2-WAY ECONOSEAL III LC / BLACK	LH REAR DOOR / DOOR CASING
WINDOW LIFT MOTOR - PASSENGER	PD5 / 2-WAY ECONOSEAL III LC / BLACK	PASSENGERS DOOR / DOOR CASING
WINDOW LIFT MOTOR - RH REAR	RDCR / 2-WAY ECONOSEAL III LC / BLACK	RH DOOR / DOOR CASING
WINDOW LIFT SWITCH PACK - LH REAR	RD1-L / 26-WAY MULTILOCK 41 / SLATE	LH REAR DOOR ARM REST/TOP ROLL
WINDOW LIFT SWITCH PACK - PASSENGER	PD1 / 26-WAY MULTILOCK 47 / SLATE	PASSENGERS DOOR ARM REST/TOP ROLL
WINDOW LIFT SWITCH PACK - RH REAR	RD1-R / 26-WAY MULTILOCK 47 / SLATE	RH REAR DOOR ARM REST/TOP ROLL

HARNESS-TO-HARNESS CONNECTORS

Connector	Type / Color	Location / Access
CA8	20-WAY MULTILOCK 040 / GREEN	DRIVERS UNDERSCUTTLE
CA9	20-WAY MULTILOCK 040 / BLACK	DRIVERS 'A' POST / 'A' POST TRIM
CA10	8-WAY MULTILOCK 070 / WHITE	DRIVERS UNDERSCUTTLE
CA11	20-WAY MULTILOCK 040 / BLACK	PASSENGERS UNDERSCUTTLE / ECM
CA12	12-WAY MULTILOCK 070 / WHITE	PASSENGERS UNDERSCUTTLE / ECM
CA13	12-WAY MULTILOCK 040 / BLACK	LH 'BC' POST / 'BC' POST PANEL
CA14	2-WAY MULTILOCK 070 / WHITE	LH 'BC' POST / 'BC' POST PANEL
CA15	12-WAY MULTILOCK 040 / BLACK	RH 'BC' POST / 'BC' POST PANEL
CA16	2-WAY MULTILOCK 070 / WHITE	RH 'BC' POST / 'BC' POST PANEL
CC3	20-WAY MULTILOCK 040 / BLACK	CENTER CONSOLE / CENTER CONSOLE GLOVE BOX
CC18	20-WAY MULTILOCK 040 / BLUE	CENTER CONSOLE / CENTER CONSOLE
FC5	THROUGH-PANEL (48 MICRO / 8) / BLACK	LH FASCIA END PANEL / OUTER AIR VENT
FC16	20-WAY MULTILOCK 040 / BLACK	PASSENGERS UNDERSCUTTLE

GROUNDS

Ground	Location / Type
CAG30L	LH 'A' POST GROUND SCREW
CAG31R	PARCEL SHELF GROUND SCREW
CAG92L	RH HEELBOARD GROUND SCREW
CAG93R	LH HEELBOARD GROUND SCREW
CCG51L	CENTER CONSOLE GROUND STUD
FCG15L	LH CONSOLE GROUND S N D

CONTROL MODULE PIN OUT INFORMATION (FOLD OUT PAGE)



The following symbols are used to represent values for Control Module Pin Out data:

I	Input	B+	Battery voltage
O	Output	V	Voltage (DC)
SG	Signal Ground	Hz	Frequency
D	Serial and encoded communications	KHz	Frequency x 1000
		MS	Milliseconds
		MV	Millivolts

CAUTION: The information on this data page is furnished to aid the user in understanding circuit operation. THIS INFORMATION SHOULD BE USED FOR REFERENCE ONLY.

NOTE: The values listed are approximately those that can be expected at the control module connector pins with all circuit connections made and all components connected and fitted. "Active" means a load is applied or a switch is ON; "Inactive" means a load is not applied or a switch is OFF.

REFER TO THE FRONT OF THE BOOK FOR ILLUSTRATIONS DETAILING THE LOCATION AND IDENTIFICATION OF COMPONENTS, RELAYS, CONNECTORS, HARNESES, GROUNDS, VEHICLE CONTROL MODULES AND CONTROL MODULE PINS.

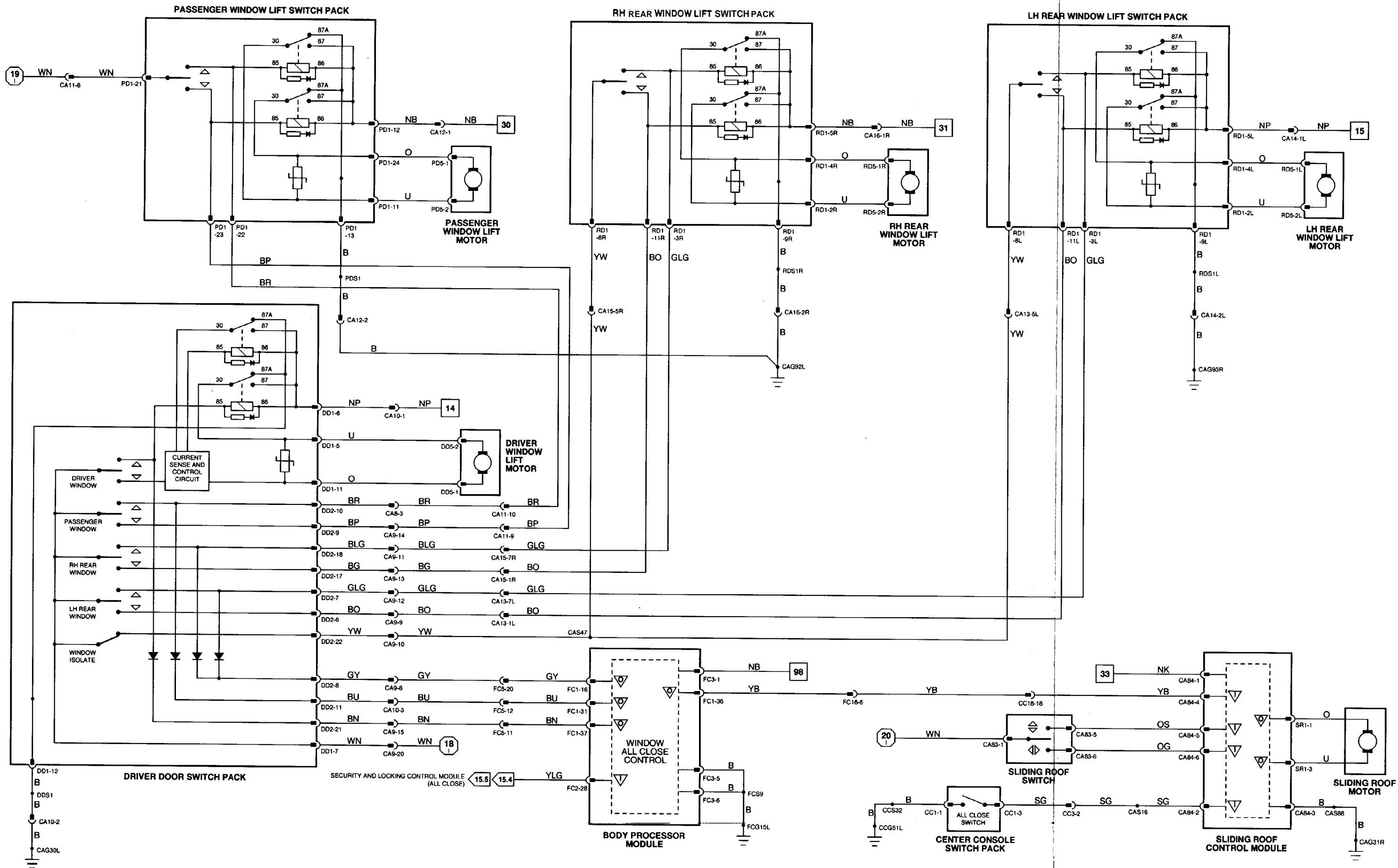

CONTROL MODULE PIN OUT INFORMATION

BODY PROCESSOR MODULE

Pin	Description	Active	Inactive
FC1-16	REAR WINDOW RAISE	GROUND	B+
FC1-31	FRONT PASSENGER WINDOW RAISE	GROUND	B+
FC1-36	SLIDING ROOF CLOSE	GROUND	B+
FC1-37	DRIVER WINDOW RAISE	GROUND	B+
FC2-28	REMOTE ALL CLOSE REQUEST	GROUND	B+

SLIDING ROOF CONTROL MODULE

Pin	Description	Active	Inactive
CAM-2	ALL CLOSE REQUEST	GROUND	B+
CA84-4	ALL CLOSE REQUEST TO BPM	GROUND	B+
CA84-5	TILT OPEN / SLIDE CLOSE REQUEST	GROUND	B+
CA84-6	TILT CLOSE / SLIDE OPEN REQUEST	GROUND	B+
SR1-1	SLIDING ROOF MOTOR	B+	GROUND
SR1-3	SLIDING ROOF MOTOR	B+	GROUND

MS Milliseconds  
MV Millivolts

CAUTION The information on this data page is furnished to aid the user in understanding circuit operation. THIS INFORMATION SHOULD BE USED FOR REFERENCE ONLY.

NOTE: The values listed are approximately those that can be expected at the control module connector pins with all circuit connections made and

Fig. 17.2

COMPONENTS

Component	Connector ■Type ■Color	Location / Access
BODY PROCESSOR MODULE	FC1 / 48-WAY PCB SIGNAL / YELLOW FC2 / 48-WAY PCB SIGNAL / BLACK FC3 / 8-WAY PCB SIGNAL / BLACK	PASSENGERS UNDERSCUTTLE
CENTER CONSOLE SWITCH PACK	CC1 / 16-WAY MULTILOCK 040 / BLACK	CENTER CONSOLE
DOOR SWITCH PACK - DRIVER	DD1 / 12-WAY MULTILOCK 47 / WHITE DD2 / 22-WAY MULTILOCK 47 / WHITE	ARM REST / TOP ROLL
SLIDING ROOF CONTROL MODULE	CA84 / 6-WAY MULTILOCK 070 / WHITE SR1 / 3-WAY MULTILOCK 070 / WHITE	ROOF CONSOLE
SLIDING ROOF MOTOR	SR1 / 3-WAY MULTILOCK 070 / WHITE	ROOF CONSOLE
SLIDING ROOF SWITCH	CA83 / 8-WAY MULTILOCK 040 / BLACK	ROOF CONSOLE
WINDOW LIFT MOTOR - DRIVER	DD5 / 2-WAY ECONOSEAL III LC / BLACK	DRIVER'S DOOR / WINDOW CASING
WINDOW LIFT MOTOR - LH REAR	RD5-L / 2-WAY ECONOSEAL III LC / BLACK	LH REAR DOOR / DOOR CASING
WINDOW LIFT MOTOR - PASSENGER	PD5 / 2-WAY ECONOSEAL III LC / BLACK	PASSENGER'S DOOR / DOOR CASING
WINDOW LIFT MOTOR - RH REAR	RD5-R / 2-WAY ECONOSEAL III LC / BLACK	RH DOOR / DOOR CASING
WINDOW LIFT SWITCH PACK - LH REAR	RD1-L / 116-WAY MULTILOCK 47 / SLATE	LH REAR DOOR ARM REST / TOP ROLL
WINDOW LIFT SWITCH PACK - PASSENGER	PO1 / 126-WAY MULTILOCK 47 / SLATE	PASSENGER'S DOOR ARM REST / TOP ROLL
WINDOW LIFT SWITCH PACK - RH REAR	RD1-R / 126-WAY MULTILOCK 47 / SLATE	RH REAR DOOR ARM REST / TOP ROLL

HARNESS-TO-HARNESS CONNECTORS

Connector	Type ■Color	Location / Access
CAB	20-WAY MULTILOCK M 0 / GREEN	DRIVER'S UNDERSCUTTLE
CA9	20-WAY MULTILOCK 040 / BLACK	DRIVER'S 'A' POST / 'A' POST TRIM
CA10	8-WAY MULTILOCK 070 / WHITE	DRIVER'S UNDERSCUTTLE
CA11	20-WAY MULTILOCK 040 / BLACK	PASSENGERS UNDERSCUTTLE / ECM
CA12	12-WAY MULTILOCK 070 / WHITE	PASSENGERS UNDERSCUTTLE / ECM
CA13	12-WAY MULTILOCK 040 / BLACK	LH 'BC' POST / 'BC' POST PANEL
CA14	2-WAY MULTILOCK 070 / WHITE	LH 'BC' POST / 'BC' POST PANEL
CA15	12-WAY MULTILOCK 040 / BLACK	RH 'BC' POST / 'BC' POST PANEL
CA16	2-WAY MULTILOCK 070 / WHITE	RH 'BC' POST / 'BC' POST PANEL
CC3	20-WAY MULTILOCK 040 / BLACK	CENTER CONSOLE / CENTER CONSOLE GLOVE BOX
CC18	20-WAY MULTILOCK M 0 / BLUE	CENTER CONSOLE / CENTER CONSOLE
FC6	THROUGH-PANEL (48 MICRO / 8) / BLACK	RH FASCIA END PANEL / OUTER AIR VENT
FC16	20-WAY MULTILOCK 040 / BLACK	PASSENGERS UNDERSCUTTLE

GROUNDS

Ground	Location ■Type
CAG30L	LH 'A' POST GROUND SCREW
CAG31R	PARCEL SHELF GROUND SCREW
CAG92L	RH HEELBOARD GROUND SCREW
CAG93R	LH HEELBOARD GROUND SCREW
CCG51L	CENTER CONSOLE GROUND STUD
FCG15L	LH CONSOLE GROUND STUD

CONTROL MODULE PIN OUT INFORMATION (FOLD OUT PAGE)



REFER TO THE FRONT OF THE BOOK FOR ILLUSTRATIONS DETAILING THE LOCATION AND IDENTIFICATION OF COMPONENTS, RELAYS.

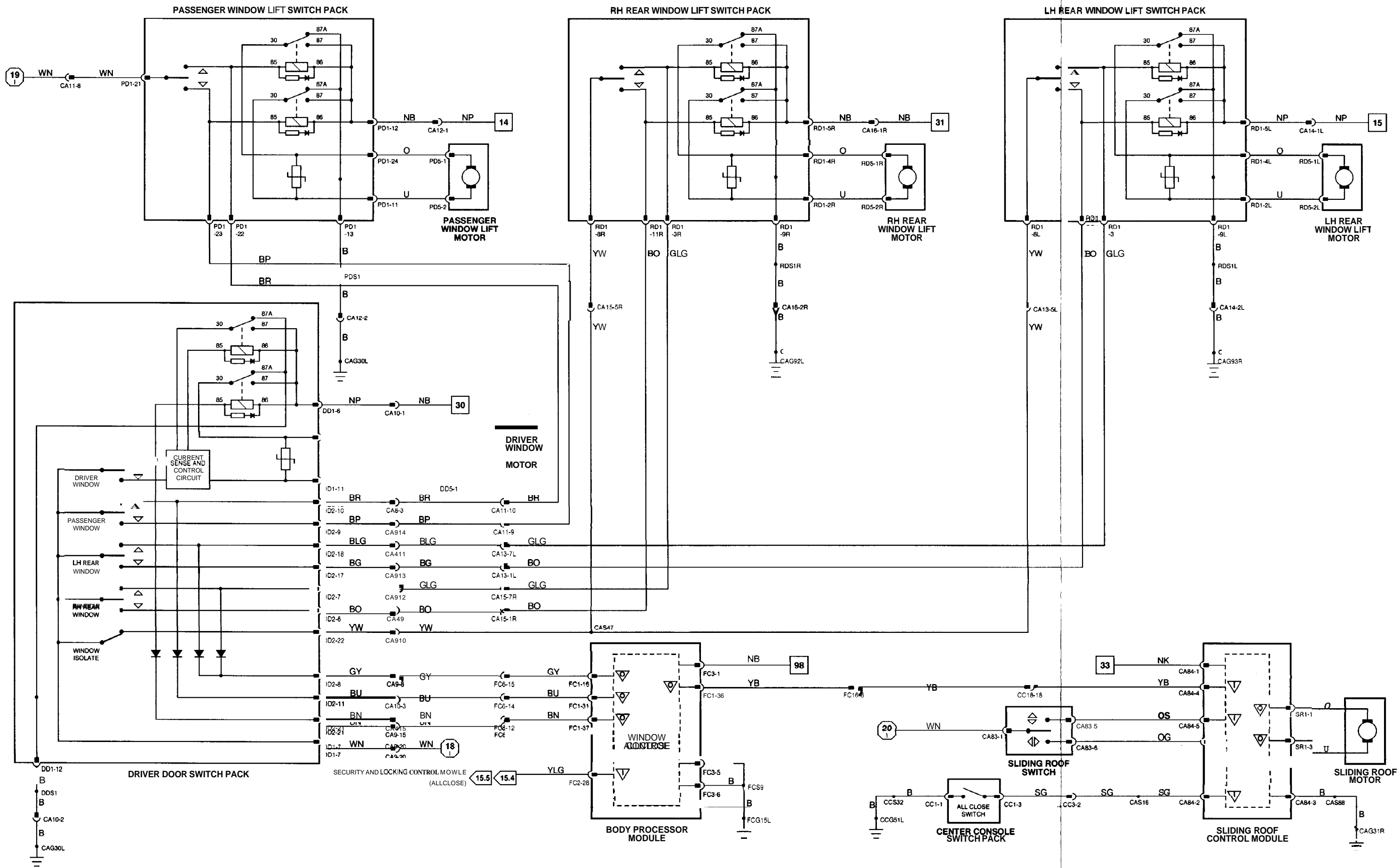

CONTROL MODULE PIN OUT INFORMATION

RADIO CASSETTE

Pin	Description	Active	Inactive
IC1-5	ANTENNA UP	B+	GROUND

**Fig. 18.1**

COMPONENTS

Component	Connector	Type	Color	Location	Access
CD AUTO CHANGER	IC5	2-WAY ANTENNA	BLACK	PARCEL SHELF	
HANDSET	RT63	8-WAY PHONE	BLACK	CENTER CONSOLE	
MICROPHONE	RT67	2-WAY MULTILOCK	BLUE	ROOF CONSOLE	
MID-BASS - LH FRONT	CA67	2-WAY MULTILOCK	040 / BLUE	DOOR CASING	
MID-BASS - LH REAR	DD6 (LHD)	IFLY LEAD	12-WAY GROTE AND HARTMAN	DOOR CASING	
MID-BASS - RH FRONT	PD6 (RHD)	IFLY LEAD	12-WAY GROTE AND HARTMAN	DOOR CASING	
MID-BASS - RH REAR	RD6-L	(FLY LEAD) / 2-WAY GROTE AND HARTMAN	BLACK	DOOR CASING	
RADIO ANTENNA	DD6 (RHD)	IFLY LEAD	12-WAY GROTE AND HARTMAN	DOOR CASING	
RADIO ANTENNA MOTOR	PD6 (LHD)	(FLY LEAD) / 2-WAY GROTE AND HARTMAN	BLACK	DOOR CASING	
RADIO CASSETTE	RD6-R	IFLY LEAD	12-WAY GROTE AND HARTMAN	DOOR CASING	
TELEPHONE ANTENNA	IC12	12-WAY ANTENNA CONNECTOR	BLACK	RH REAR FENDER / TRUNK TRIM	
TELEPHONE TRANSCEIVER	BT44	6 WAY YAZAKI	WHITE	TRUNK, RH SIDE	
TWEETER - LH FRONT, STANDARD ICE	IC1	120-WAY MULTILOCK	0701 WHITE	TRUNK TRIM	
TWEETER - LH REAR, STANDARD ICE	IC13	2-WAY ANTENNA CONNECTOR	WHITE	CENTER CONSOLE	
TWEETER - RH FRONT, STANDARD ICE	IC19	CD AUTOCHANGER CONNECTOR		HEADLINER, REAR	
TWEETER - RH REAR, STANDARD ICE	RT65	ANTENNA CONNECTOR	BLACK	PARCEL SHELF / TRUNK TRIM	
	RT62	25 WAY D TYPE	BLACK	FASCIA, LH SIDE	
	RT64	ANTENNA CONNECTOR	1 BLACK	PARCEL SHELF, LH SIDE	
	FC32	IFLY LEAD	12-WAY MODU	FASCIA, LH SIDE	
	CA81	IFLY LEAD	12-WAY MODU	PARCEL SHELF, LH SIDE	
	FC31	IFLY LEAD	12-WAY MODU	FASCIA, LH SIDE	
	CA82	IFLY LEAD	12-WAY MOOU	PARCEL SHELF, RH SIDE	

HARNESS-TO-HARNESS CONNECTORS

Connector	Type	Color	Location	Access
ET4	THROUGH-PANEL	48 MICRO / 6	BLACK	PARCEL SHELF / FUEL TANK TRIM
CA77	2-WAY MULTILOCK	070	YELLOW	LH 'A' POST / 'A' POST PANEL
CA78	2-WAY MULTILOCK	070	YELLOW	PASSENGER'S 'A' POST / 'A' POST PANEL
CA79	2-WAY MULTILOCK	070	YELLOW	LH 'BC' POST / 'BC' POST PANEL
CA80	4 WAY MULTILOCK	040	BLACK	RH 'E' POST LAMP
IC2	8-WAY MULTILOCK	0701	WHITE	RH TRUNK TRIM PANEL / FUEL TANK TRIM
IC7	8 WAY MULTILOCK	0701	WHITE	PASSENGERS UNDERSCUTTLE
IC22	18-WAY MULTILOCK	070	WHITE	LH REAR DOOR / DOOR CASING
IC23	4-WAY MULTILOCK	0401	BLACK	LH HEELBOARD / HEELBOARD COVER
RT61	12-WAY MULTILOCK	040	BLACK	PARCEL SHELF
RT66	10-WAY YAZAKI		BLACK	PARCEL SHELF

GROUNDS

Ground	Location	Type
BTG18R	REAR TRUNK	GROUND STUD
CAG91	PARCEL SHELF	GROUND SCREW
CEG2	RADIO	GROUND STUD
ICG24	RADIO	GROUND STUD

CONTROL MODULE PIN OUT INFORMATION (FOLD OUT PAGE)



The following symbols are used to represent values for Control Module Pin Out data:

- I Input
- O output
- SG Signal Ground
- D Serial and encoded communications
- B+ Battery voltage
- V Voltage (DC)
- Hz Frequency
- KHz Frequency x 1000
- MS Milliseconds
- MV Millivolts

CAUTION: The information on this data page is furnished to aid the user in understanding circuit operation. THIS INFORMATION SHOULD BE USED FOR REFERENCE ONLY.

NOTE: The values listed are approximately those that can be expected at the control module connector pins with all circuit connections made and all components connected and fitted. "Active" means a load is applied or a switch is ON; "Inactive" means a load is not applied or a switch is OFF.

REFER TO THE FRONT OF THE BOOK FOR ILLUSTRATIONS DETAILING THE LOCATION AND IDENTIFICATION OF COMPONENTS, RELAYS, CONNECTORS, HARNESSSES, GROUNDS, VEHICLE CONTROL MODULES AND CONTROL MODULE PINS.



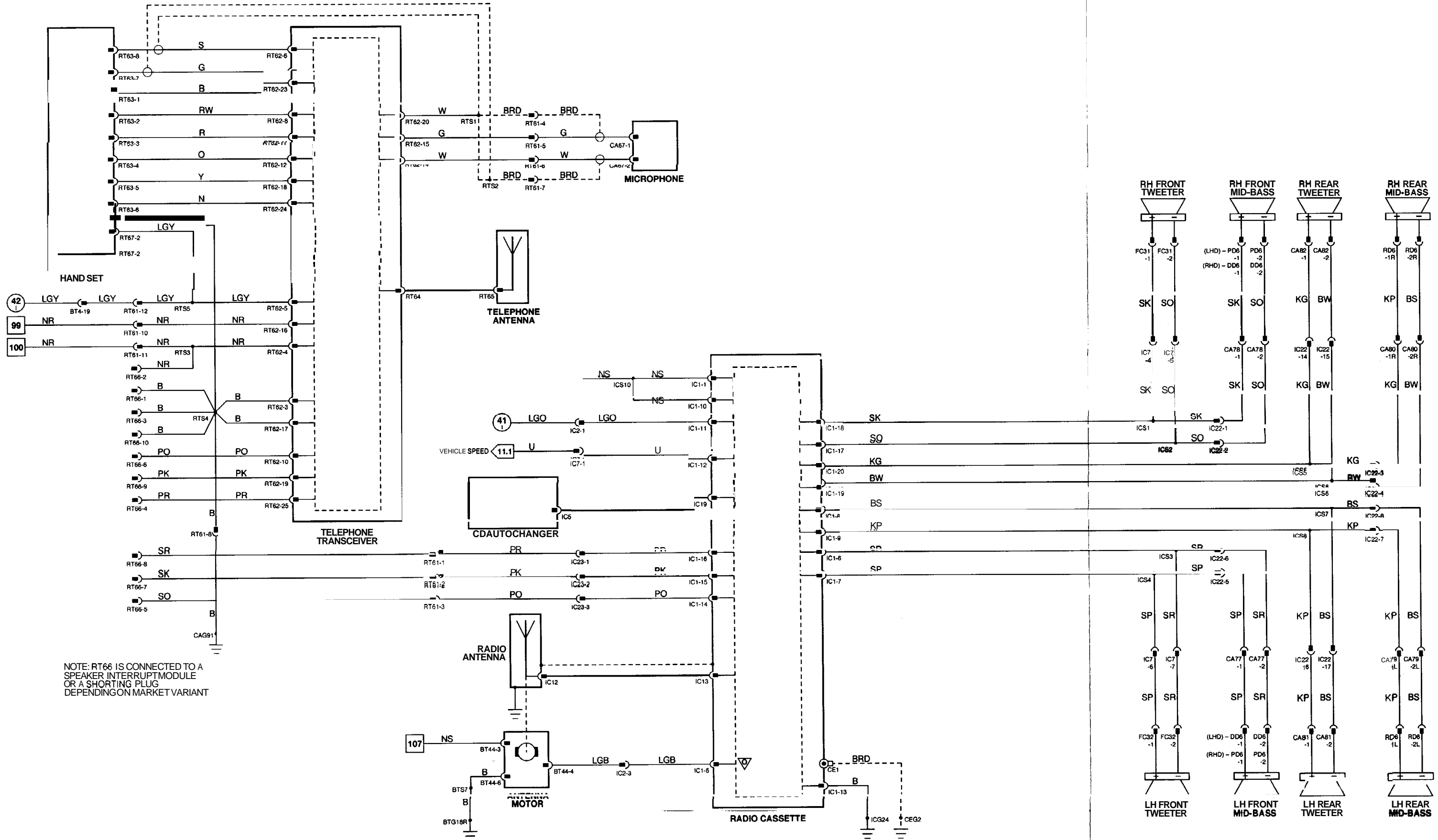

NOTE: RT66 IS CONNECTED TO A SPEAKER INTERRUPT MODULE OR A SHORTING PLUG DEPENDING ON MARKET VARIANT

CONTROL MODULE PIN OUT INFORMATION

POWER AMPLIFIER

Pin	Description	Active	Inactive
I IC30-1	RH REAR CHANNEL LOW LEVEL INPUT	0 - 30 MV	0 MV
I IC30-2	RH FRONTCHANNEL LOW LEVEL INPUT	0 - 30 MV	0 MV
SG IC30-3	SIGNAL GROUND	GROUND	GROUND
I IC30-6	LH REAR CHANNEL LOW LEVEL INPUT	0 - 30 MV	0 MV
I IC30-7	LH FRONT CHANNEL LOW LEVEL INPUT	0 - 30 MV	0 MV

RADIO CASSETTE

Pin	Description	Active	Inactive
O IC1-5	ANTENNA UPIAMPLIFIER ON SIGNAL	B+	GROUND
O IC34-1	RH FRONT CHANNEL LOW LEVEL OUTPUT	0 - 30 MV	0 MV
O IC34-2	LH FRONTCHANNEL LOW LEVEL OUTPUT	0 - 30 MV	0 MV
SG IC34-3	SIGNAL GROUND	GROUND	GROUND
O IC34-4	LH REAR CHANNEL LOW LEVEL OUTPUT	0 - 30 MV	0 MV
O IC34-5	RH REAR CHANNEL LOW LEVEL OUTPUT	0 - 30 MV	0 MV

Fig. 18.2

COMPONENTS

Component	Connector / Type / Color	Location / Access
CD AUTO CHANGER HANDSET	IC5 / 2-WAY ANTENNA/BLACK RT63 / 8-WAY PHONE / BLACK RT67 / 2-WAY MULTILOCK 0401/B L U E	PARCEL SHELF CENTER CONSOLE
MICROPHONE MIDBASS - LH FRONT	CA67 / 2-WAY MULTILOCK 0401/B L U E DD6 (LHD) (FLY LEAD) / 2-WAY GROTE AND HARTMAN / BLACK DD6 (RHD) (FLY LEAD) / 2-WAY GROTE AND HARTMAN / BLACK	ROOF CONSOLE DOOR CASING
MIDBASS - LH REAR MIDBASS - RH FRONT	RDBL (FLY LEAD) / 2-WAY GROTE AND HARTMAN / BLACK DD6 (RHD) (FLY LEAD) / 2-WAY GROTE AND HARTMAN / BLACK DD6 (LHD) (FLY LEAD) / 2-WAY GROTE AND HARTMAN / BLACK	DOOR CASING W D R CASING
MIDBASS - RH REAR POWER AMPLIFIER	DD6-R (FLY LEAD) / 2-WAY GROTE AND HARTMAN / BLACK IC30 / 12-WAY MULTILOCK 070 / WHITE IC31 / 18-WAY MULTILOCK 070 / WHITE	DOOR CASING PARCEL SHELF / TRUNK TRIM
RADIO ANTENNA RADIO ANTENNA MOTOR RADIO CASSETTE	IC12 12-WAY ANTENNA CONNECTOR / BLACK BT44 / 16-WAY YAZAKI / WHITE IC1 / 20-WAY MULTILOCK 070 / WHITE IC13 12-WAY ANTENNA CONNECTOR / WHITE IC19 / CD AUTOCHANGER CONNECTOR IC34 / 16-WAY DIN / SLATE	RH REAR FENDER / TRUNK TRIM TRUNK, RH SIDE / TRUNK TRIM CENTER CONSOLE
SUBWOOFER	IC32 (FLY LEAD) / 2-WAY GROTE AND HARTMAN / BLACK IC33 (FLY LEAD) / 2-WAY GROTE AND HARTMAN / BLACK	PARCEL SHELF / TRUNK TRIM
TELEPHONE ANTENNA TELEPHONE TRANSCEIVER	RT65 / ANTENNA CONNECTOR / BLACK RT62 / 125-WAY D TYPE / BLACK RT64 / ANTENNA CONNECTOR / BLACK	HEADLINER, REAR PARCEL SHELF / TRUNK TRIM
TWEETER - LH FRONT, PREMIUM ICE TWEETER - LH REAR, PREMIUM ICE TWEETER - RH FRONT, PREMIUM ICE TWEETER - RH REAR, PREMIUM ICE	CA102 (FLY LEAD) / 2-WAY MULTILOCK 040 / BLACK MB1-L (FLY LEAD) / 2-WAY MODU / BLACK CA101 (FLY LEAD) / 2-WAY MULTILOCK 040 / BLACK MB1-R (FLY LEAD) / 2-WAY MODU / BLACK	FASCIA, LH SIDE PARCEL SHELF, LH SIDE FASCIA, RH SIDE PARCEL SHELF, RH SIDE

HARNESS-TO-HARNESS CONNECTORS

Connector	Type / Color	Location / Access
BT4	THROUGH-PANEL (48 MICRO / 6) / BLACK	PARCEL SHELF / FUEL TANK TRIM
CA77	2-WAY MULTILOCK 0701 / YELLOW	LH 'A' POST / 'A' POST PANEL
CA10	2-WAY MULTILOCK 070 / YELLOW	PASSENGER'S 'A' POST / 'A' POST PANEL
CA79	2-WAY MULTILOCK 070 / YELLOW	LH 'BC' POST / 'BC' POST PANEL
CA80	4-WAY MULTILOCK MO / BLACK	RH "E" POST LAMP
IC2	8-WAY MULTILOCK 070 / WHITE	RH TRUNK TRIM PANEL / FUEL TANK TRIM
IC7	8-WAY MULTILOCK 070 / WHITE	PASSENGER'S UNDERSCUTTLE
IC22	18-WAY MULTILOCK 0701 / WHITE	LH REAR DOOR / W O R CASING
IC23	4-WAY MULTILOCK 040 / BLACK	LH HEELBOARD / HEELBOARD COVER
RT61	12-WAY MULTILOCK MO / B L K K	PARCEL SHELF
RT66	10-WAY YAZAKI / BLACK	PARCEL SHELF

GROUNDS

Ground	Location / Type
BTG18R	REAR TRUNK GROUND STUD
CAG91	PARCEL SHELF GROUND SCREW
CEG2	RADIO GROUND STUD
ICG16L	FRONT TRUNK GROUND STUD
ICG16R	FRONT TRUNK GROUND STUD
ICG24	RADIO GROUND STUD

CONTROL MODULE PIN OUT INFORMATION (FOLD OUT PAGE)



The following symbols are used to represent values for Control Module Pin Out data:

I	Input	B+	Battery voltage
O	Output	V	Voltage (DC)
SG	Signal Ground	Hz	Frequency
D	Serial and encoded communications	KHz	Frequency x 1000
		MS	Milliseconds
		MV	Millivolts

CAUTION: The information on this data page is furnished to aid the user in understanding circuit operation. THIS INFORMATION SHOULD BE USED FOR REFERENCE ONLY.

NOTE: The values listed are approximately those that can be expected at the control module connector pins with all circuit connections made and all components connected and fitted. "Active" means a load is applied or a switch is ON; "Inactive" means a load is not applied or a switch is OFF.

REFER TO THE FRONT OF THE BOOK FOR ILLUSTRATIONS DETAILING THE LOCATION AND IDENTIFICATION OF COMPONENTS, RELAYS, CONNECTORS, HARNESSSES, GROUNDS, VEHICLE CONTROL MODULES AND CONTROL MODULE PINS.

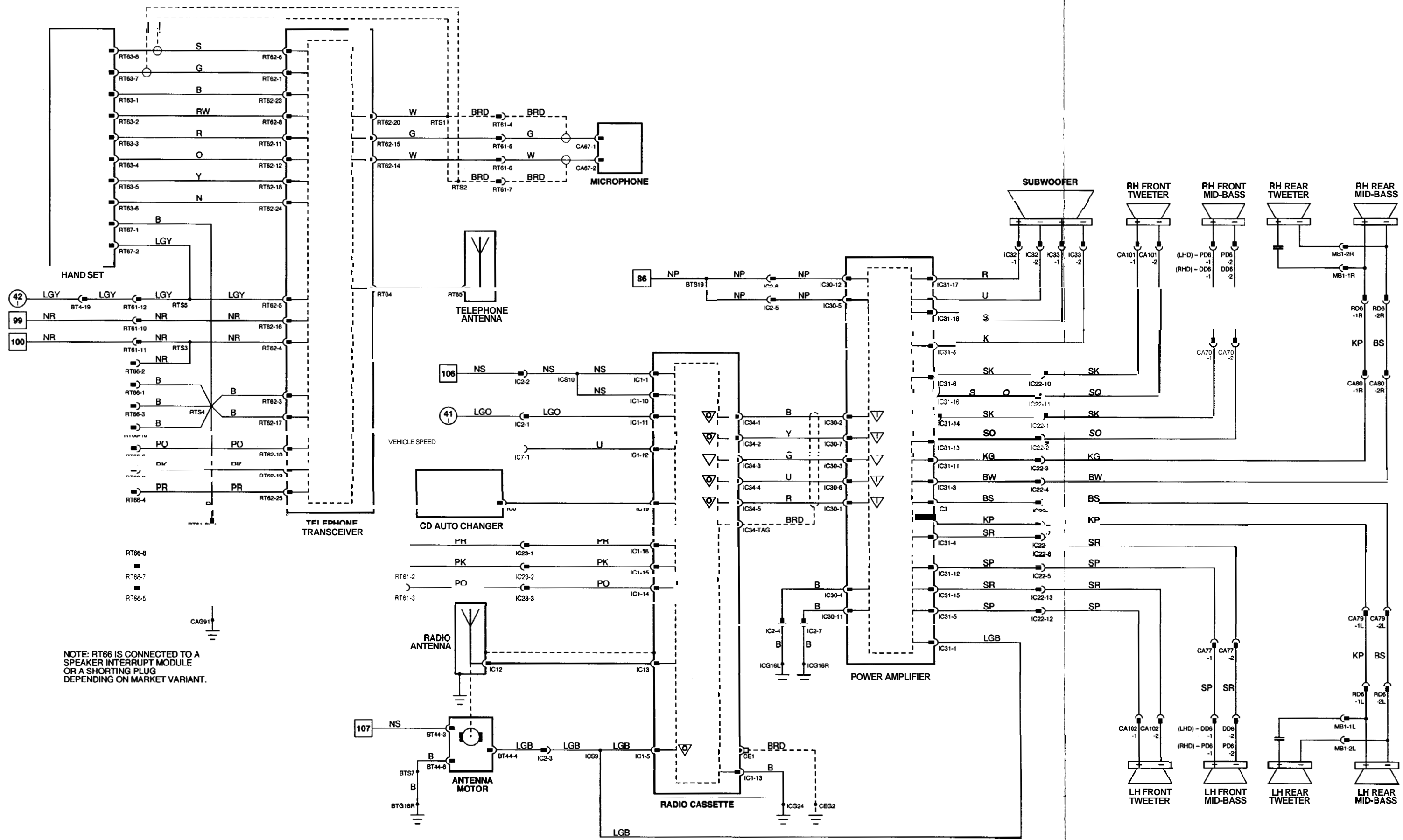

NOTE: RT66 IS CONNECTED TO A SPEAKER INTERRUPT MODULE OR A SHORTING PLUG DEPENDING ON MARKET VARIANT.

- RT66-8
- RT66-7
- RT66-5

CONTROL MODULE PIN OUT INFORMATION

POWER AMPLIFIER

Pin	Description	Active	Inactive
I IC30-1	RH REAR CHANNEL LOW LEVEL INPUT	0 - 30 MV	0 MV
I IC30-2	RH FRONT CHANNEL LOW LEVEL INPUT	0 - 30 MV	0 MV
SG IC30-3	SIGNAL GROUND	GROUND	GROUND
I IC30-6	LH REAR CHANNEL LOW LEVEL INPUT	0 - 30 MV	0 MV
I IC30-7	LH FRONT CHANNEL LOW LEVEL INPUT	0 - 30 MV	0 MV

RADIO CASSETTE

Pin	Description	Active	Inactive
O IC1-5	ANTENNA UP / AMPLIFIER ON SIGNAL	B+	GROUND
O IC34-1	RH FRONT CHANNEL LOW LEVEL OUTPUT	0 - 30 MV	0 MV
O IC34-2	LH FRONT CHANNEL LOW LEVEL OUTPUT	0 - 30 MV	0 MV
SG IC34-3	SIGNAL GROUND	GROUND	GROUND
O IC34-4	LH REAR CHANNEL LOW LEVEL OUTPUT	0 - 30 MV	0 MV
O ICY-5	RH REAR CHANNEL LOW LEVEL OUTPUT	0 - 30 MV	0 MV

Fig. 18.3

COMPONENTS

Component	Connector / Type / Color	Location / Access
CD AUTO CHANGER HANDSET	IC5 / 2-WAY ANTENNA / BLACK RT63 / 8-WAY PHONE / BLACK RT67 / 2-WAY MULTILOCK 040 / BLUE	PARCEL SHELF / CENTER CONSOLE
MICROPHONE MIDBASS - LH FRONT	CA67 / 2-WAY MULTILOCK 040 / BLUE	ROOF CONSOLE
MIDBASS - LH REAR	DD6 ILHD IFLY LEAD / 12-WAY GROTE AND HARTMAN / BLACK PD6 (RHD) IFLY LEAD / 12-WAY GROTE AND HARTMAN / BLACK	DOOR CASING
MIDBASS - RH FRONT	DD6-L IFLY LEAD / 12-WAY GROTE AND HARTMAN / BLACK	DOOR CASING
MIDBASS - RH REAR	DD6 (RHD) IFLY LEAD / 12-WAY GROTE AND HARTMAN / BLACK PD6 (LHD) IFLY LEAD / 2-WAY GROTE AND HARTMAN / BLACK	DOOR CASING
POWER AMPLIFIER	DD6-R (FLY LEAD) / 12-WAY GROTE AND HARTMAN / BLACK IC30 / 12-WAY MULTILOCK 070 / WHITE IC31 / 18-WAY MULTILOCK 070 / WHITE	PARCEL SHELF / TRUNK TRIM
RADIO ANTENNA	IC12 / 2-WAY ANTENNA CONNECTOR / BLACK	RH REAR FENDER / TRUNK TRIM
RADIO ANTENNA MOTOR	BT44 / 6-WAY YAZAKI / WHITE	TRUNK, RH SIDE / TRUNK TRIM
RADIO CASSETTE	IC1 / 12-WAY MULTILOCK 070 / WHITE IC13 / 12-WAY ANTENNA CONNECTOR / WHITE IC19 / CD AUTOCHANGER CONNECTOR IC34 / 6-WAY DIN LLATE	CENTER CONSOLE
SUBWOOFER	IC32 (FLY LEAD) / 12-WAY GROTE AND HARTMAN / BLACK IC33 IFLY LEAD / 12-WAY GROTE AND HARTMAN / BLACK	PARCEL SHELF / TRUNK TRIM
TELEPHONE ANTENNA	RT65 / ANTENNA CONNECTOR / BLACK	HEADLINER, REAR
TELEPHONE TRANSCEIVER	RT62 / 125-WAY DWPE / BLACK RT64 / ANTENNA CONNECTOR / BLACK	PARCEL SHELF / TRUNK TRIM
TWEETER - LH FRONT, PREMIUM ICE	CA102 (FLY LEAD) / 12-WAY MULTILOCK 0M / BLACK	FASCIA, LH SIDE
TWEETER - LH REAR, PREMIUM ICE	MB1-L IFLY LEAD / 12-WAY MODU / BLACK	PARCEL SHELF, LH SIDE
TWEETER - RH FRONT, PREMIUM ICE	CA101 IFLY LEAD / 2-WAY MULTILOCK 0M / BLACK	FASCIA, RH SIDE
TWEETER - RH REAR, PREMIUM ICE	MB1-R IFLY LEAD / 12-WAY MODU / BLACK	PARCEL SHELF, RH SIDE

HARNESS-TO-HARNESS CONNECTORS

Connector	Type / Color	Location / Access
BT4	THROUGH-PANEL (48 MICRO / 0) / BLACK	PARCEL SHELF / FUEL TANK TRIM
CA77	2-WAY MULTILOCK 070 / YELLOW	LH 'A' POST / 'A' POST PANEL
CA78	2-WAY MULTILOCK 070 / YELLOW	PASSENGERS 'A' POST / 'A' POST PANEL
CA79	2-WAY MULTILOCK 070 / YELLOW	LH 'BC' POST / 'BC' POST PANEL
CA80	4-WAY MULTILOCK 040 / BLACK	RH 'E' POST LAMP
IC2	SWAY MULTILOCK 070 / WHITE	RH TRUNK TRIM PANEL / FUEL TANK TRIM
IC7	8-WAY MULTILOCK 070 / WHITE	PASSENGERS UNDERSCUTTLE
IC22	18-WAY MULTILOCK 070 / WHITE	LH REAR DOOR / DOOR CASING
IC23	4-WAY MULTILOCK 0M / BLACK	LH HEELBOARD / HEELBOARD COVER
RT61	12-WAY MULTILOCK 040 / BLACK	PARCEL SHELF

GROUNDS

Ground	Location / Type
BTG18R	REAR TRUNK GROUND STUD
CAG91	PARCEL SHELF GROUND SCREW
CEG2	RADIO GROUND STUD
ICG16L	FRONT TRUNK GROUND STUD
ICG16R	FRONT TRUNK GROUND STUD
ICG24	RADIO GROUND STUD

CONTROL MODULE PIN OUT INFORMATION (FOLDOUT PAGE)



The following symbols are used to represent values for Control Module Pin Out data:

I	Input	B+	Battery voltage
O	Output	V	Voltage (DC)
SG	Signal Ground	Hz	Frequency
D	Serial and encoded communications	KHz	Frequency x 1000
		MS	Milliseconds
		MV	Millivolts

CAUTION The information on this data page is furnished to aid the user in understanding circuit operation. THIS INFORMATION SHOULD BE USED FOR REFERENCE ONLY.

NOTE: The values listed are approximately those that can be expected at the control module connector pins with all circuit connections made and all components connected and fitted. "Active" means a load is applied or a switch is ON; "Inactive" means a load is not applied or a switch is OFF.

REFER TO THE FRONT OF THE BOOK FOR ILLUSTRATIONS DETAILING THE LOCATION AND IDENTIFICATION OF COMPONENTS, RELAYS, CONNECTORS, HARNESSES, GROUNDS, VEHICLE CONTROL MODULES AND CONTROL MODULE PINS.

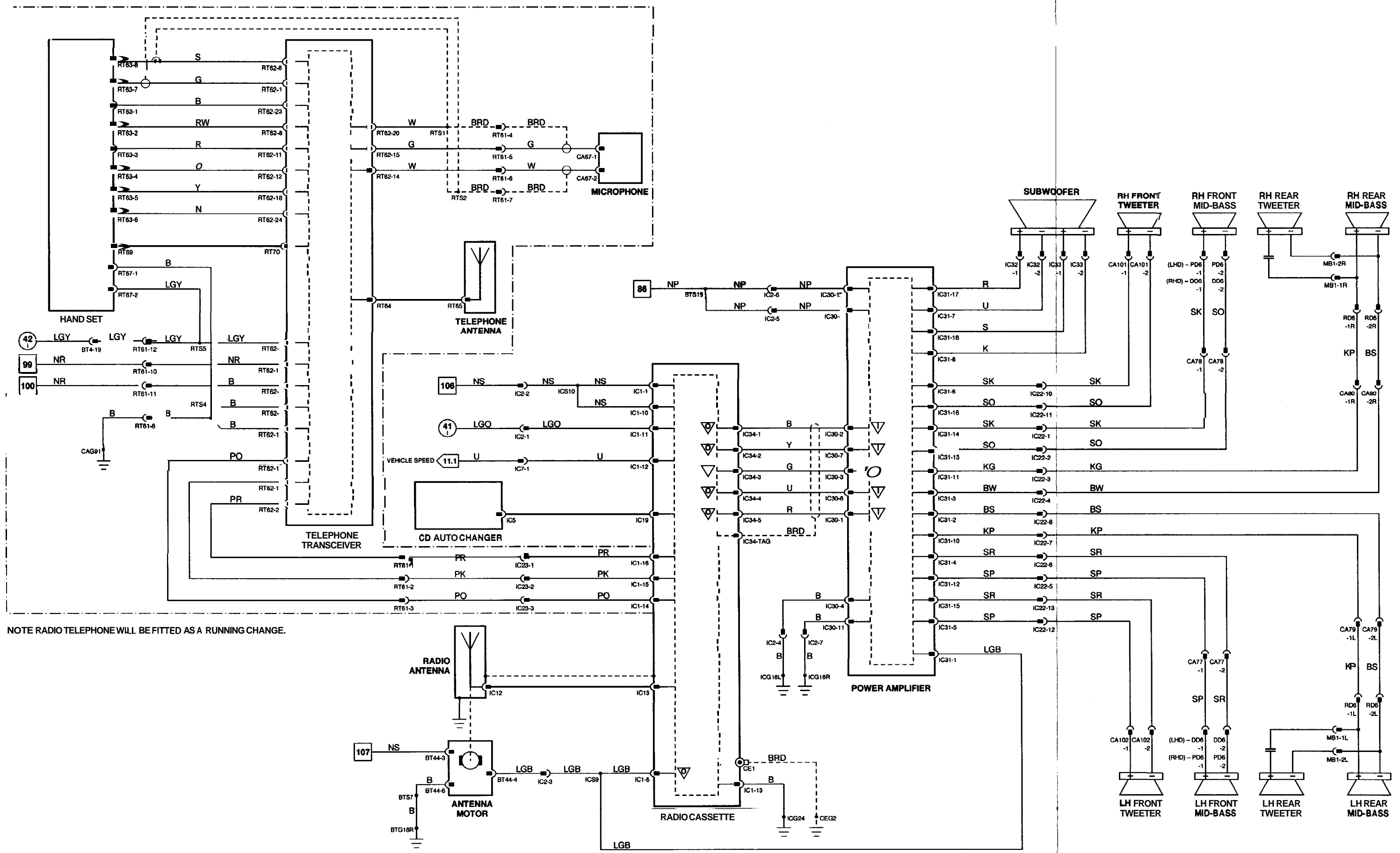

NOTE RADIO TELEPHONE WILL BE FITTED AS A RUNNING CHANGE.

**Fig. 19.1**

**COMPONENTS**

Component	Connector / Type / Color	Location / Access
AIR BAG DIAGNOSTIC MONITOR	AB1 / 12-WAY FORD CARD / SLATE AB2 / 12-WAY FORD CARD / BLACK	PASSENGER'S UNDERSCUTTLE
AIR BAG - DRIVER SIDE	AB0 (FLY LEAD) / 13-WAY EPC / YELLOW	STEERING WHEEL
AIR BAG - PASSENGER SIDE (NAS ONLY)	AB8 (FLY LEAD) / 3-WAY EPC / YELLOW	PASSENGER'S FASCIA
IMPACT SENSOR - LH	CL1 / CWAY FORD CARD / NATURAL	BEHIND LH HEADLAMP
IMPACT SENSOR - RH	CR1 / 4-WAY FORD CARD / NATURAL	BEHIND RH HEADLAMP
SAFING SENSOR	AB3 / 8-WAY FORD CARD / NATURAL	RH 'A' POST / 'A' POST TRIM

**HARNESSTO-HARNESCONNECTORS**

Connector	Type / Color	Location / Access
AB7	3-WAY EPC / YELLOW	DRIVER'S UNDERSCUTTLE
AB11	4-WAY FORD CARD / NATURAL	RH 'A' POST / 'A' POST PANEL
AB12	CWAY FORD CARD / NATURAL	LH 'A' POST / 'A' POST PANEL
CA25	3-WAY MULTILOCK 070 / YELLOW	RH 'A' POST, ECM 'A' POST PANEL
FC6	THROUGH-PANEL (48 MICRO / 6) / BLACK	RH FASCIA END PANEL / OUTER AIR MNT

**GROUNDS**

Ground	Location / Type
CLG2	AIR BAG GROUND SCREW



AIR BAG FAILURE WARNING

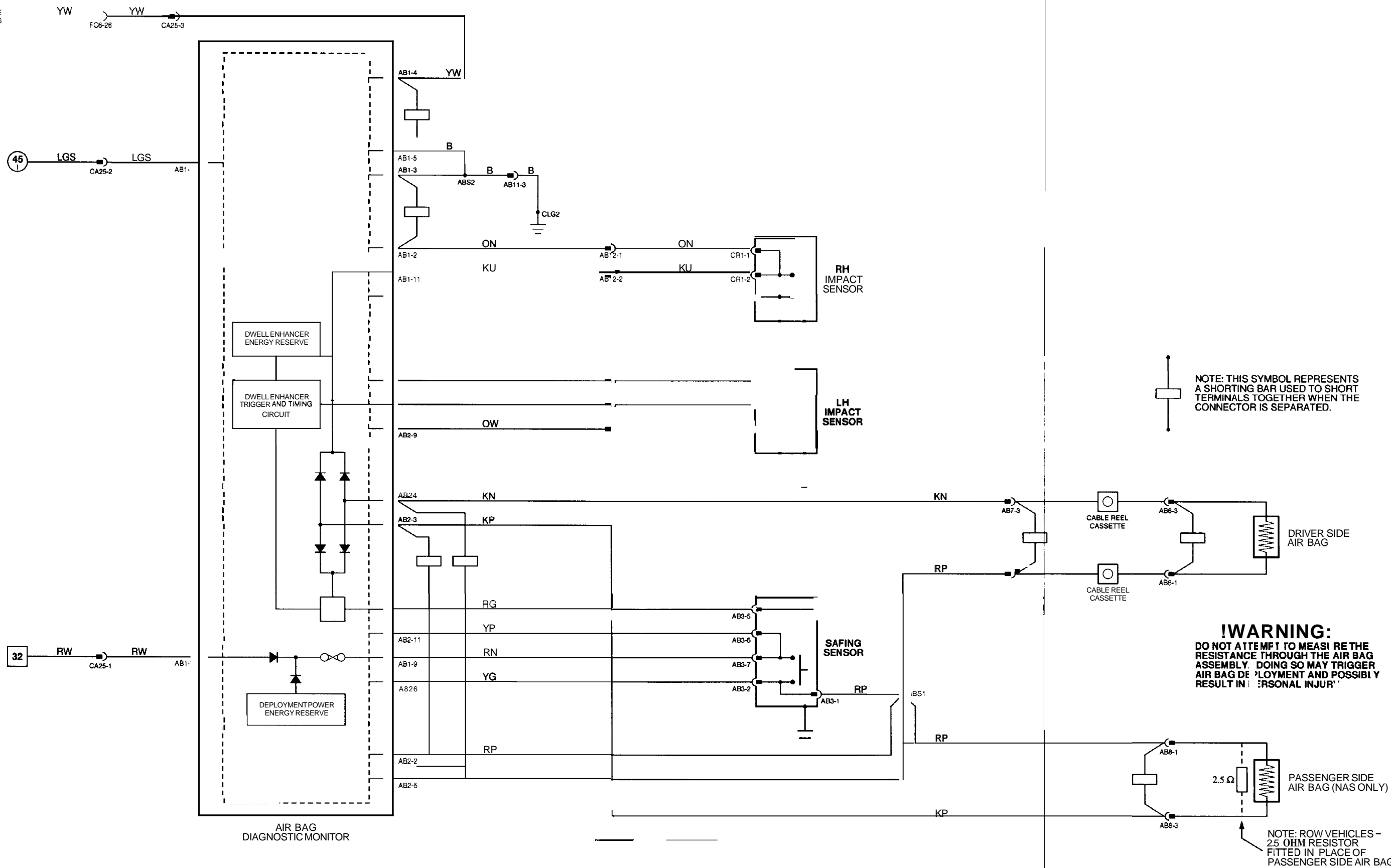

**Fig. 20.1**

**COMPONENTS**

Component	Connector / Type / Color	Location / Access
ACCESSORY CONNECTOR - CABIN	CA71 / 3-WAY SERIES 250 / BLACK	LH 'A' POST / 'A' POST TRIM
ACCESSORY CONNECTOR - TRUNK	BT12 13-WAY SERIES 250 / BLACK	TRUNK ELECTRICAL CARRIER
CARAVAN / TRAILER CONNECTOR	BT19 12-WAY ECONOSEAL III HC / BLACK	BEHIND BATTERY / TRUNK FLOOR TRIM
CIGAR LIGHTER - FRONT	CCS / 2-WAY SERIES 250 / BLACK CC10 / LUCAR / BLACK	CENTER CONSOLE
CIGAR LIGHTER - REAR	CC16 / 2-WAY SERIES 250 / BLACK CC17 / LUCAR / BLACK	CENTER CONSOLE
ELECTROCHROMIC REAR VIEW MIRROR	CA85 / 3-WAY MULTILOCK 070 / WHITE	ROOF CONSOLE
FOLD-BACK MIRROR SWITCH	FM1 / 7-WAY FORD / BLACK	DRIVER'S DOOR SWITCH PACK / TOP ROLL ARM REST
FOLD-BACK MIRROR - DRIVER	DD10 / FLY LEAD / 12-WAY MULTILOCK 040 / BLACK	MIRROR ASSEMBLY
FOLD-BACK MIRROR - PASSENGER	PD10 / (FLY LEAD) / 12-WAY MULTILOCK 040 / BLACK	MIRROR ASSEMBLY
HORN SWITCHES	SC9 / 2-WAY MULTILOCK 040 / BLACK	STEERING WHEEL
HORN - LH	LS43 / LUCAR / BLACK LS44 / LUCAR / BLACK	BEHIND FRONT GRILLE
HORN - RH	RS43 / LUCAR / BLACK RS44 / LUCAR / BLACK	BEHIND FRONT GRILLE
FUSE BOX - LH ENGINE BAY	LS1 / 10-WAY UTA / BLACK LS37 / 10-WAY UTA / BLACK	ENGINE BAY, LH FRONT
UNIVERSAL GARAGE W/O R OPENER (INTERIOR MAP LAMP CONSOLE)	RIBBON CONNECTOR	ROOF CONSOLE

**RELAYS**

Relay	Color / Stripe	Connector / Color	Location / Access
ACCESSORY RELAY	BLACK / VIOLET	BT7 / BLACK	TRUNK ELECTRICAL CARRIER
CIGAR LIGHTER RELAY	BLACK / BLUE	CA57 / BLUE	RH HEELBOARD
HORN RELAY (LH ENGINE BAY FUSE BOX)	BLUE	— / BLACK	LH ENGINE BAY FUSE BOX

**HARNESS-TO-HARNESS CONNECTORS**

Connector	Type / Color	Location / Access
BT4	THROUGH-PANEL (48 MICRO / 6) / BLACK	PARCEL SHELF / FUEL TANK TRIM
CA8	20-WAY MULTILOCK 040 / GREEN	DRIVER'S UNDERSCUTTLE
CAS	20-WAY MULTILOCK 040 / BLACK	DRIVER'S 'A' POST / 'A' POST TRIM
CA10	8-WAY MULTILOCK 070 / WHITE	DRIVER'S 'A' POST / 'A' POST TRIM
CA11	20-WAY MULTILOCK 040 / BLACK	PASSENGERS UNDERSCUTTLE / ECM
CA03	8-WAY MULTILOCK 040 / BLACK	ROOF CONSOLE
CC4	14-WAY MULTILOCK 070 / WHITE	CENTER CONSOLE / CENTER CONSOLE GLOVE BOX
DD16	6-WAY MULTILOCK 040 / BLACK	DRIVER'S DOOR / W/O R CASING
FC4	20-WAY MULTILOCK 040 / BLUE	DRIVER'S UNDERSCUTTLE
FC5	THROUGH-PANEL (48 MICRO / 6) / BLACK	LH FASCIA END PANEL / OUTER AIR VENT
LS3	THROUGH-PANEL (48 MICRO / 6) / BLACK	LH 'A' POST / 'A' POST PANEL
PI59	13-WAY ECONOSEAL III LC / BLACK	LH AIR CLEANER
PI61	13-WAY ECONOSEAL III LC / BLACK	RH AIR CLEANER

**GROUNDS**

Ground	Location / Type
BTG18L	REAR TRUNK GROUND STUD
BTG18R	REAR TRUNK GROUND STUD
BTG49R	REAR TRUNK GROUND STUD
CAG30L	LH 'A' POST GROUND SCREW
CAG31R	PARCEL SHELF GROUND SCREW
CAG33L	RH HEELBOARD GROUND SCREW
CAG32R	RH HEELBOARD GROUND SCREW
CCGML	CENTER CONSOLE GROUND
CCGMR	CENTER CONSOLE GROUND
FCG26R	LH CONSOLE GROUND STUD
RSG8L	RIGHT FORWARD GROUND STUD

REFER TO THE FRONT OF THE BOOK FOR ILLUSTRATIONS DETAILING THE LOCATION AND IDENTIFICATION OF COMPONENTS, RELAYS, CONNECTORS, HARNESSSES, GROUNDS, VEHICLE CONTROL MODULES AND CONTROL MODULE PINS.



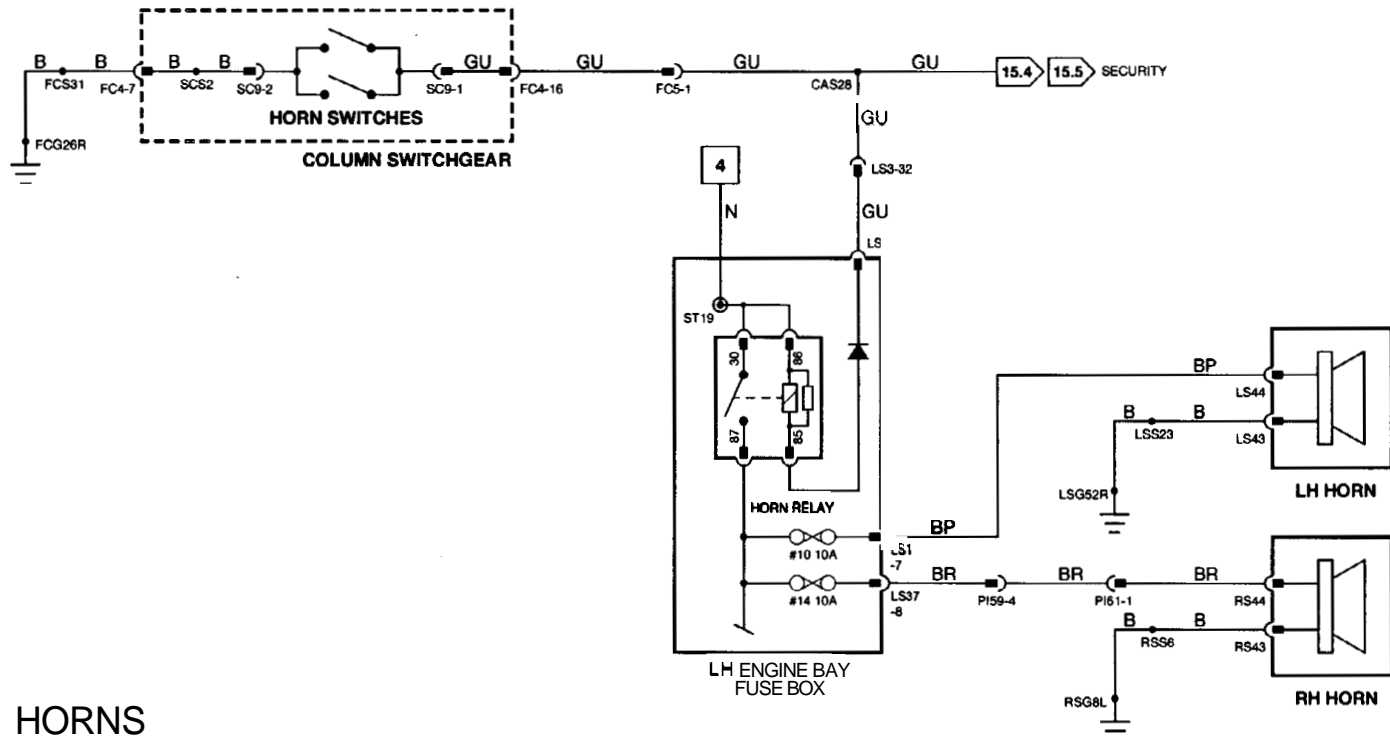

HORNS

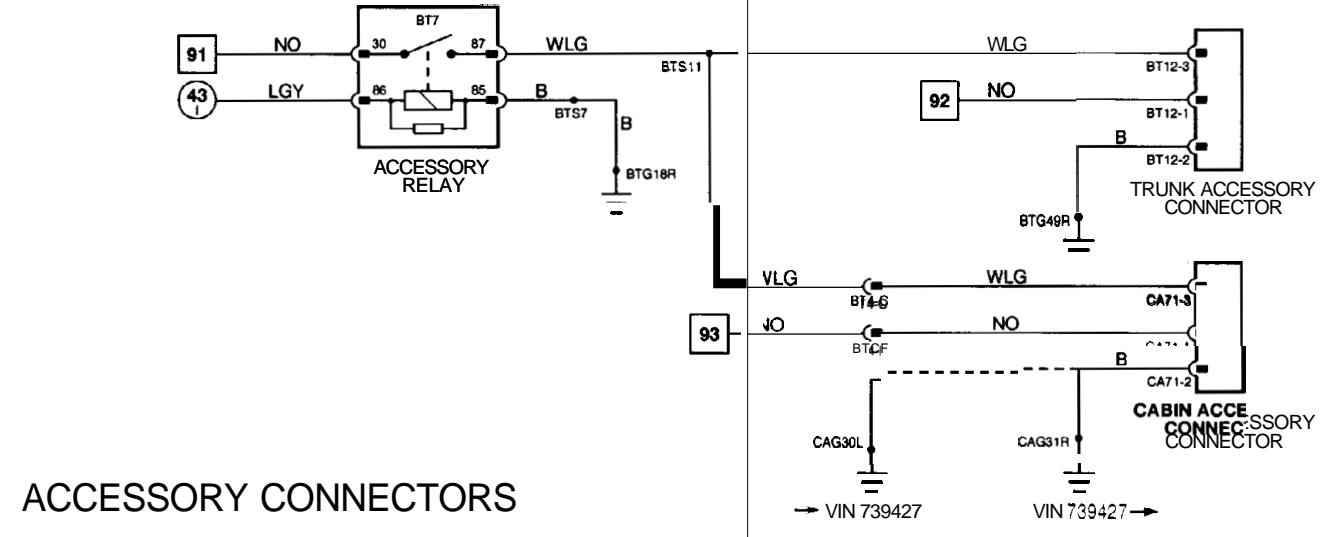

ACCESSORY CONNECTORS

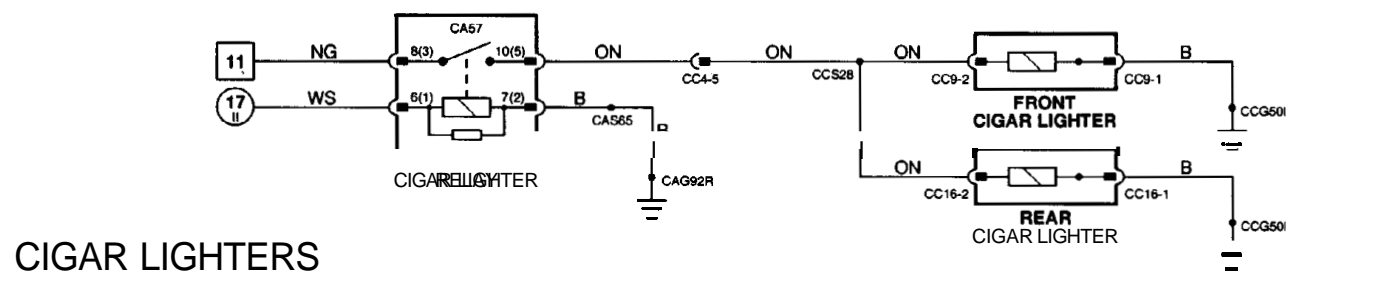

CIGAR LIGHTERS

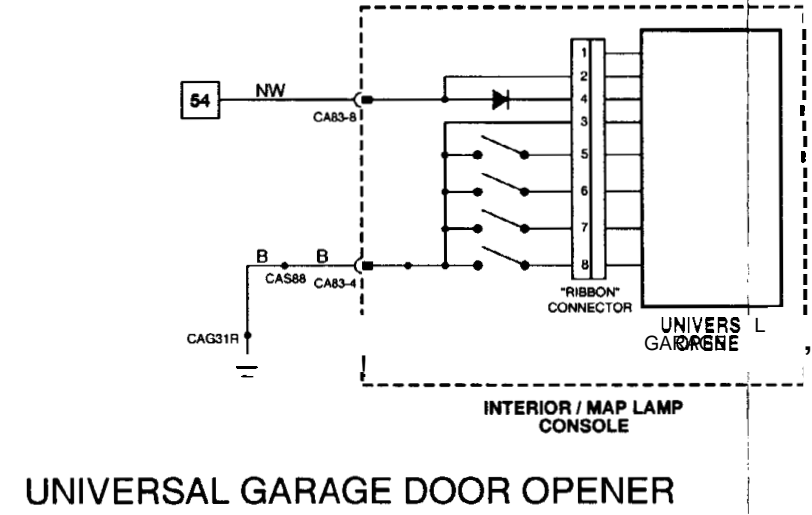

UNIVERSAL GARAGE DOOR OPENER

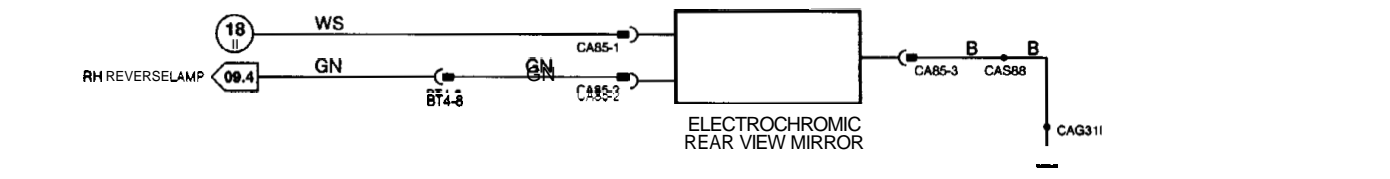

ELECTROCHROMIC REAR VIEW MIRROR

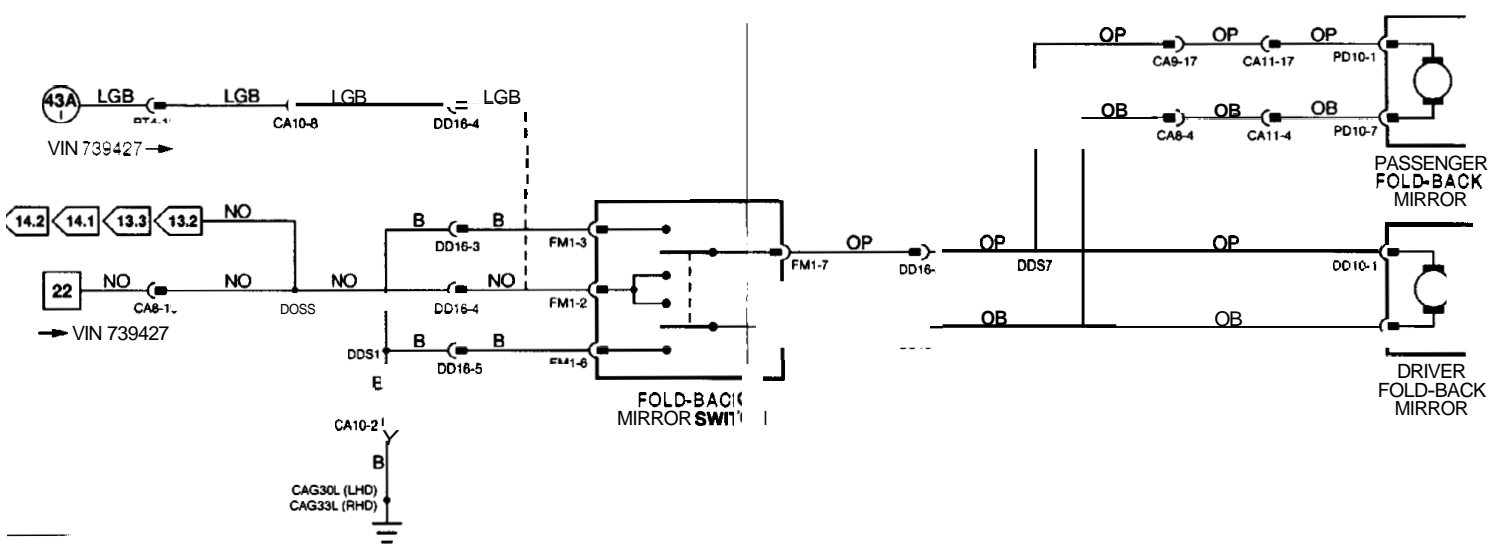

FOLD-BACK MIRRORS



CARAVAN / TRAILER CONNECTOR

**Fig. 21.1**

**COMPONENTS**

Component	Connector / Type / Color	Location / Access
ABS / TRACTION CONTROL CONTROL MODULE (LHD) ABS / TRACTION CONTROL CONTROL MODULE (RHD) AIR CONDITIONING CONTROL MODULE	RS27 / 128-WAY FORDGTE / SLATE LS27 / 28-WAY FORDGTE / SLATE CC28 / 26-WAY MULTILOCK 47 / SLATE CC29 / 16-WAY MULTILOCK 47 / SLATE CC30 / 12-WAY MULTILOCK 47 / SLATE CC31 / 122-WAY MULTILOCK 47 / SLATE	ENGINE BAY / RH REAR ENGINE BAY / LH REAR A/C UNIT, RH SIDE / RH UNDERSCUTTLE
BODY PROCESSOR MODULE	FC1 / 48-WAY PCB SIGNAL / YELLOW FC2 / 48-WAY PCB SIGNAL / BLACK FC3 / 6-WAY PCB SIGNAL / BLACK	PASSENGER'S UNDERSCUTTLE
COLUMN / MIRROR MOVEMENT CONTROL MODULE	F / W / 26-WAY MULTILOCK 47 / SLATE FC46 / 16-WAY MULTILOCK 47 / SLATE FC47 / 12-WAY MULTILOCK 47 / SLATE CC6 / 16-WAY OBD II / SLATE	RH UNDERSCUTTLE
DATA LINK CONNECTOR ENGINE CONTROL MODULE IN161	PI104 / 36-WAY ECONOSEAL III / BLACK PI105 / 36-WAY ECONOSEAL III / RED	DRIVER'S 'A' POST RH 'A' POST / 'A' POST TRIM
ENGINE CONTROL MODULE (V12)	PI44 / 128-WAY MULTILOCK M 0 / SLATE PI45 / 116-WAY MULTILOCK 040 / SLATE PI46 / 22-WAY MULTILOCK 040 / SLATE PI47 / 34-WAY MULTILOCK 040 / SLATE	RH 'A' POST / 'A' POST TRIM
INSTRUMENT PACK	FC9 / 124-WAY IDC / BLACK FC10 / 148-WAY IDC / BLACK	INSTRUMENT PACK
SEAT CONTROL MODULE - DRIVER (NAS VEHICLES)	CA106 / 22-WAY MULTILOCK 47 / BLUE CA108 / 12-WAY MULTILOCK 47 / BLUE SM1-D / 12-WAY MULTILOCK 47 / BLUE SM6-D / 122-WAY MULTILOCK 47 / WHITE	DRIVER'S SEAT
SEAT CONTROL MODULE - DRIVER (ROW, MEMORY SEAT VEHICLES)	PL1 / 122-WAY MULTILOCK 47 / BLUE PL2 / 12-WAY MULTILOCK 47 / BLUE SM1-D / 12-WAY MULTILOCK 47 / BLUE SM6-D / 16-WAY MULTILOCK 47 / BLACK	DRIVERS SEAT
SEAT CONTROL MODULE - PASSENGER (NAS VEHICLES)	CA107 / 122-WAY MULTILOCK 47 / BLUE CA108 / 12-WAY MULTILOCK 47 / BLUE SM1-P / 12-WAY MULTILOCK 47 / WHITE SM6-P / 122-WAY MULTILOCK 47 / WHITE	PASSENGERS SEAT
SEAT CONTROL MODULE - PASSENGER (ROW, MEMORY SEAT VEHICLES)	PL1 / 22-WAY MULTILOCK 47 / BLUE PL2 / 12-WAY MULTILOCK 47 / BLUE SM1-P / 12-WAY MULTILOCK 47 / W SM6-P / 22-WAY MULTILOCK 47 / WHITE	PASSENGERS SEAT
SECURITY AND LOCKING CONTROL MODULE	CA18 / 12-WAY MULTILOCK 47 / SLATE CA19 / 22-WAY MULTILOCK 47 / SLATE CA20 / 16-WAY MULTILOCK 47 / SLATE CA21 / 126-WAY MULTILOCK 47 / SLATE	TRUNK, LH FRONT / TRUNK TRIM
TRANSMISSION CONTROL MODULE (V12)	CC7 / 155-WAY BOSCH / BLACK CC48 / 55-WAY AMP 55 / BLACK	PASSENGER'S UNDERSCUTTLE PASSENGER'S UNDERSCUTTLE

**HARNESSTO-HARNESCONNECTORS**

Connector	Type / Color	Location / Access
CA23	20-WAY MULTILOCK 040 / BLACK	DRIVERS SEAT
CA28	20-WAY MULTILOCK 040 / BLACK	PASSENGER'S SEAT
CC18	20-WAY MULTILOCK 040 / BLUE	CENTER CONSOLE / CENTER CONSOLE GLOVE BOX
CC3	20-WAY MULTILOCK M 0 / BLACK	CENTER CONSOLE / CENTER CONSOLE GLOVE BOX
FC7	THROUGH-PANEL / 48 MICRO / 6 / BLACK	PASSENGERS UNDERSCUTTLE
LS3	THROUGH-PANEL / 48 MICRO / 6 / BLACK	LH 'A' POST / A POST PANEL
PI59	13-WAY ECONOSEAL III LC / BLACK	LH AIR CLEANER
RS3	THROUGH-PANEL / 48 MICRO / 6 / BROWN	RH 'A' POST / A POST PANEL

**GROUNDS**

Ground	Location / Type
CCG51L	CENTER CONSOLE GROUND STUD

REFER TO THE FRONT OF THE BOOK FOR ILLUSTRATIONS DETAILING THE LOCATION AND IDENTIFICATION OF COMPONENTS, RELAYS, CONNECTORS, HARNESSES, GROUNDS, VEHICLE CONTROL MODULES AND CONTROL MODULE PINS.

