



### 10.1.3 Steering Hydraulic System Major Components

- Engine driven rotary vane pump (belt driven 12 cylinder; direct drive from timing gear 6 cylinder) with falling flow characteristic (as pump speed increases fluid flow decreases) and integral pressure relief valve.
- Remote fluid reservoir with integral 'return' side filter.
- Steering rack (incorporating speed sensitive transducer).
- Steering control module (SCM).
- Fluid cooler integral with engine coolant radiator and associated pipe-work.

### 10.1.4 Hydraulic System Features

The 'Servotronic' system reduces steering input loads during parking and low speed manoeuvres and progressively increases input loads as vehicle speed rises. This feature enhances steering feel.

### 10.1.5 Hydraulic System Operating Principle (see illustrations on next three pages)

Rotary motion of the steering wheel is converted, via the steering gear pinion to lateral motion of the rack. Hydraulic assistance is provided by pressurized fluid being directed against the rack bar piston in the rack cylinder. The pressure applied to each side of the rack piston is controlled by the pinion valve which varies the restriction through which the flow for each side of the rack piston must pass.

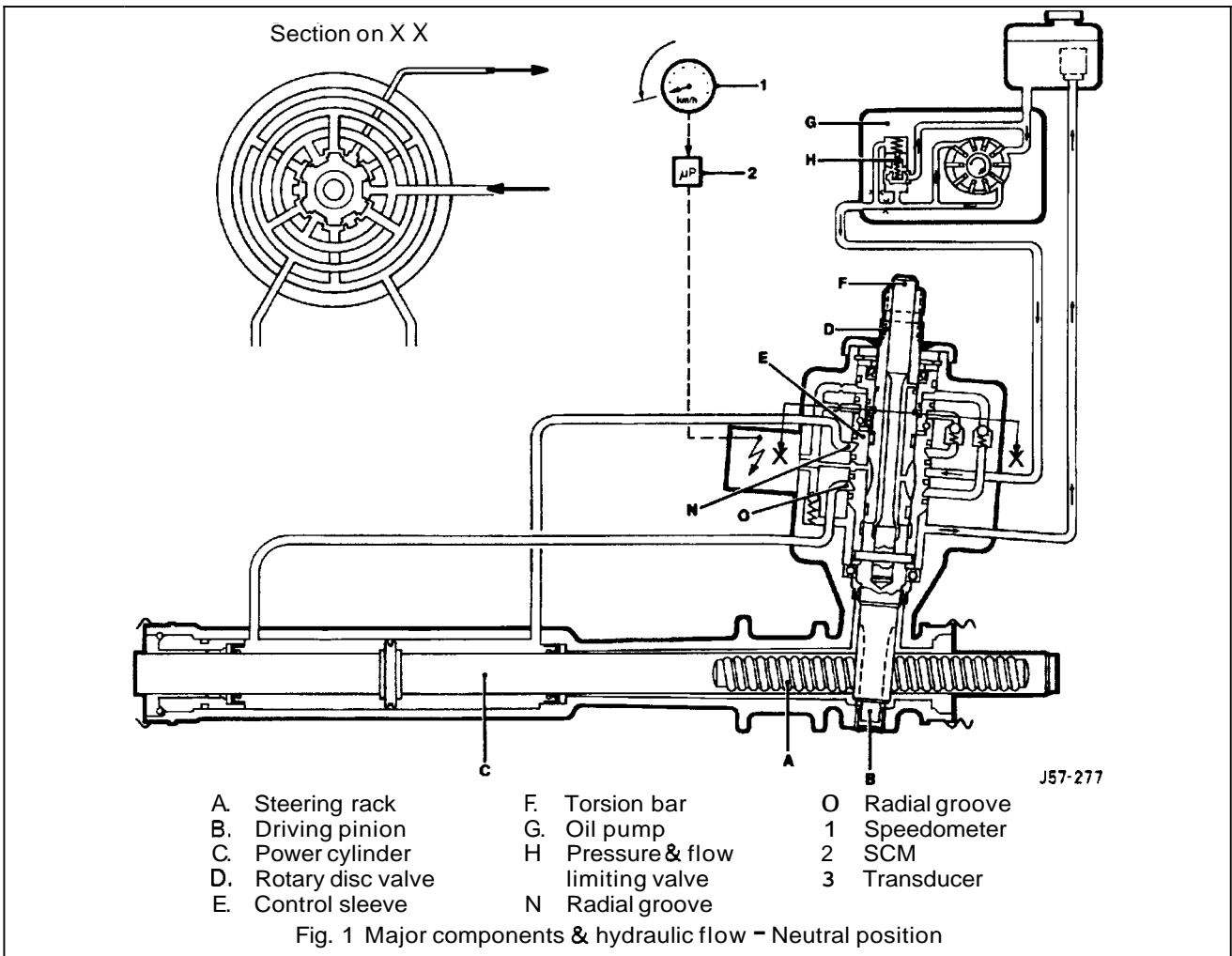



With the vehicle travelling straight ahead, the valve restrictions are balanced, thus providing equal pressure on each side of the piston. When load is applied at the steering wheel the two halves of the pinion valve are displaced making the restrictions unequal. The differential pressure then directs the rack piston in favour of the higher pressure. As the turning load is removed the pressures equalize and the steering returns to the straight ahead position, aided by suspension geometry.

The displacement of the halves of the pinion valve (rotor and sleeve) is controlled by the elastic deformation of the torsion bar which is concentric with the pinion and valve.

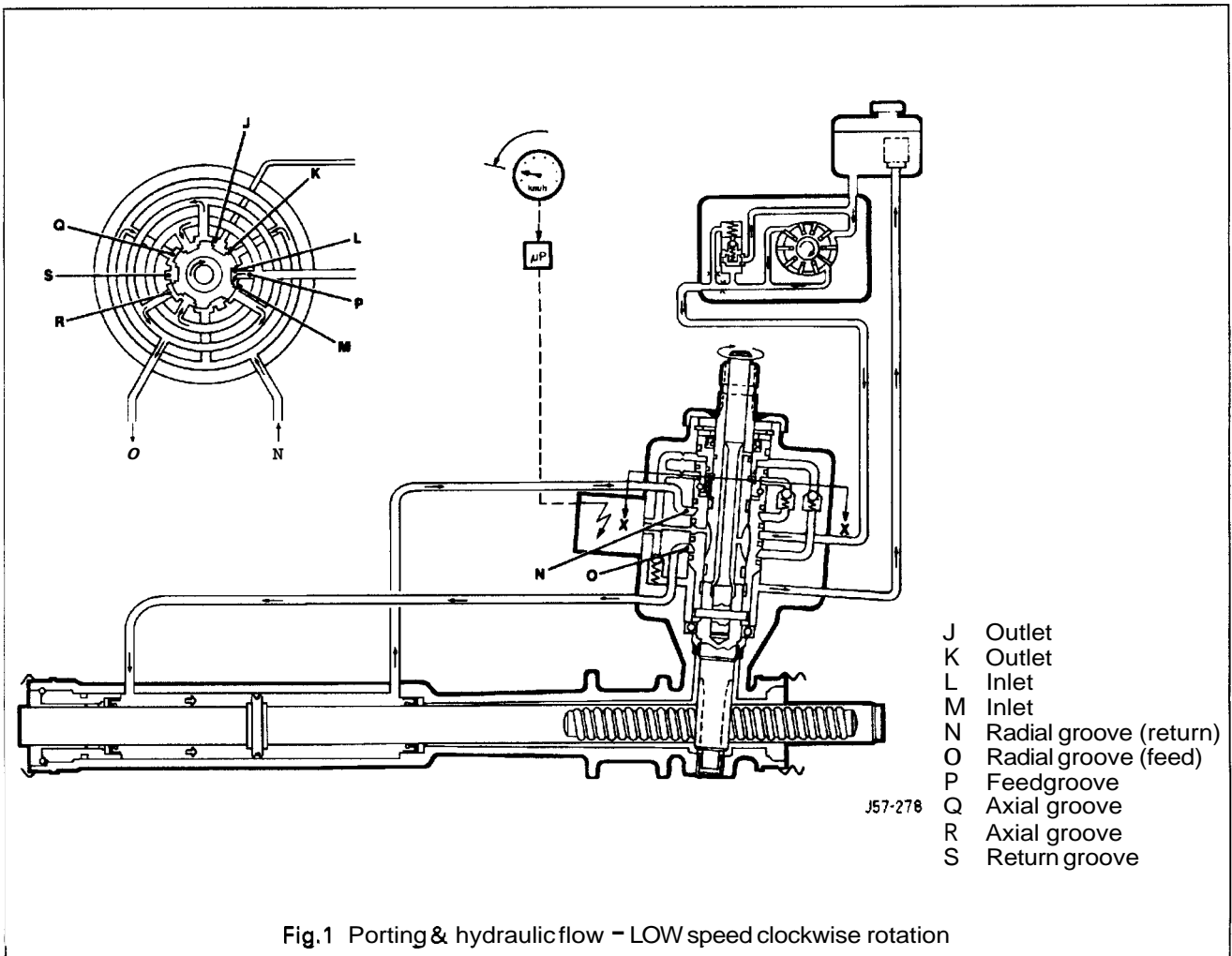



The rotary valve within the pinion housing on the 'Servotronic' system is fitted with a 'Hydraulic Reaction Piston' (HRP). The HRP moves axially, relative to the rotor, on ball bearing travellers (acting as a face cam) and is connected to the sleeve by a four bearing helical screw. Pressure applied either side of the HRP is translated into a rotational force which resists torsion bar/valve displacement thus increasing steering effort. The amount of pressure applied to the HRP is controlled by: a) the differential pressure on the rack piston, proportional to vehicle cornering force and b) the position of the transducer valve controlled by the SCM from information gathered on road speed. Road speed data is processed from the left hand rear wheel speed sensor.

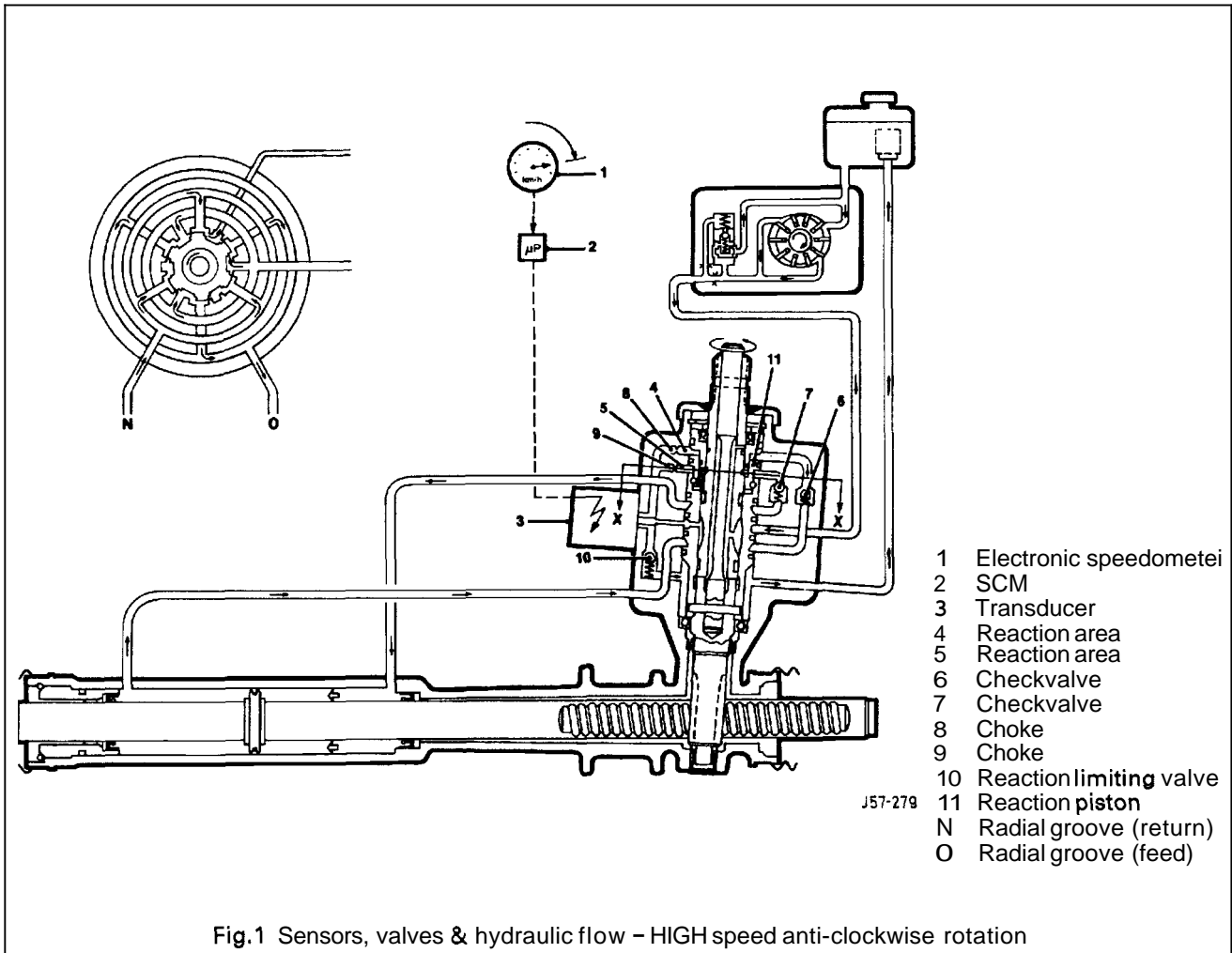

10



## 10.2 SERVICE PROCEDURES – SAFETY RELATED

### 10.2.1 Airbag

The electrically activated driver's side airbag is attached to the steering wheel hub and is fed by two wires from the column stalk assembly. Electrical input to the column stalk assembly for the airbag is provided by a dedicated harness which is encased in a yellow sleeve. A mechanism in the stalk assembly called the 'cable reel cassette' provides continuity from the static column to the steering wheel. The 'cable reel cassette' is driven by a tang which locates in the steering wheel. Because the connection is by wires, and the cassette assembly is only capable of approximately five (5) full turns, it is critically important that initial positioning is correct, see Section 15.

It is equally important that fitting of the steering wheel, connection of the column, lower shaft and steering rack should ONLY be made with the steering rack in the center of its travel.

**WARNING: DO NOT REMOVE THE STEERING COLUMN FROM THE VEHICLE WITH THE STEERING WHEEL ATTACHED UNLESS THE STEERING IS CENTERED AND THE COLUMN LOCK IS ENGAGED. IF THE LOCK BARREL IS TO BE RENEWED, LOCK-WIRE THE ASSEMBLY TO PREVENT ROTATION. FAILURE TO OBSERVE THIS AND CONSEQUENT DAMAGE TO THE 'CABLE REEL CASSETTE' MAY RESULT IN AN INOPERATIVE AIRBAG SYSTEM. SEE LABEL ON STEERING WHEEL HUB.**

## 10.3 SERVICE PROCEDURES

### 10.3.1 Working Practices

It is not recommended that either the steering rack or engine driven pump assemblies are repaired in any way other than in accordance with the repair procedures described in this manual. The fluid reservoir and filter is a disposable assembly and no attempt should be made to clean it internally. Genuine replacement units must be fitted following routine service or diagnostic confirmation of the failure of any component.

The importance of cleanliness cannot be over-stressed, not only with new parts but also those which may have failed. In-service contamination of the hydraulic system is a major cause of failures and may be avoided with good working practices and care. All new units and pipes must be supplied with suitable blanks in every orifice. Should a unit not have blanks fitted, do not use it – return it to the supplier with an appropriate reason for your action.

To help the manufacturer diagnose problems and avoid post-removal contamination; provide full details of the fault and plug all connections as soon as they are released. All suspect units must be returned to Jaguar Cars complete with relevant documentation.

**CAUTION: It is imperative that the power steering system does not become contaminated in any way. Always decant fluid from a fresh sealed container and clean the area around the reservoir neck both before and after topping-up. Never return drained fluid to the system.**

### 10.3.2 Fluid Level Check and Top-up

Position the vehicle on a level surface with the engine stationary and fluid cold. Add fluid, if required, so that the level falls BETWEEN the marks Fig.1.

### 10.3.3 System Bleed (following maintenance)

To avoid fluid aeration and possible pump damage, the initial fill process must be carried out with the ignition OFF. Set the fluid level approximately 20 mm above the upper dipstick level, and cycle the steering no less than three (3) times from lock to lock (this may be best achieved with the front wheels off the ground). As air is expelled the fluid level will fall, the level should be corrected. Start the engine and further cycle the steering until the fluid level becomes stable. Stop the engine and finally set the level in accordance with the fluid level check procedure.

### 10.3.4 Fluid Reservoir

The reservoir has an integral, non-serviceable, return-side filter. Should any component be renewed or the system 'broken into' for any reason, it is essential that the reservoir and the fluid are changed. Under normal operating conditions it is not necessary to change the fluid.

### 10.3.5 Hydraulic Connections

All hydraulic connections and surrounding areas should be scrupulously cleaned before and after work. Please note that the steering rack valve block connections for FEED and RETURN are common in size. Ensure that the pipes are correctly fitted, the uppermost one being the high pressure FEED from the steering pump and the lower (RETURN) having a double depth hexagon tube nut.

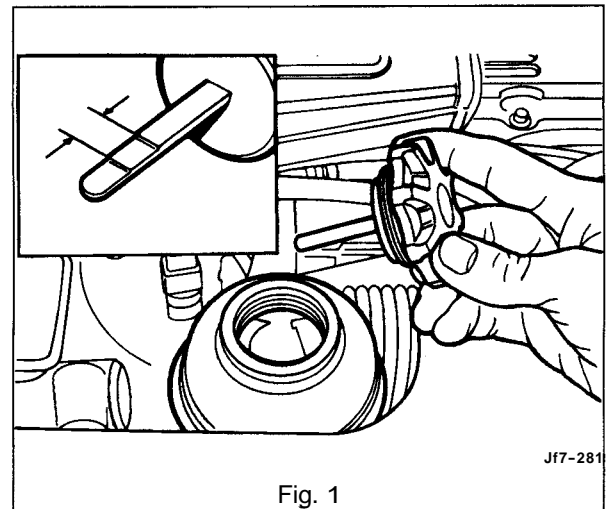

Fig. 1



## 10.4 DIAGNOSTIC PROCEDURE

### 10.4.1 Introduction

The following diagnostic procedures are provided to rapidly pin-point mechanical faults which are not interrogated by electrical means. Diagnostic procedures which require dedicated electrically operated equipment are dealt with in the 'Electrical Diagnostic Manual' (EDM) but may be mentioned here for reference.

### 10.4.2 Preliminary Action

Before any problem solving is undertaken it is essential that the fluid level and where applicable, belt tension, is checked and if required corrected.

**CAUTION:** It is imperative that the power steering system does not become contaminated in any way. Always decant fluid from a fresh sealed container and clean the area around the reservoir neck both before and after topping-up. Never return drained fluid to the system.

### 10.4.2 Diagnostic Chart 1

| Trouble                                     | Cause   | Remedy  |
|---|---|---|
| Heavy on both sides                         | Fluid level low?<br>Drive belt slack (V12)<br>Pump drive loose (6cyl)<br>center pressures low<br>Air in system due to loose connection<br>Pump shaft seal faulty (fluid loss)<br>Delivery pressure or flow too low<br>Return flow restricted by blocked reservoir filter<br>Both check valves blocked<br>Rack damper too tight<br>Lower column incorrectly set<br>Excessive upper column friction | Rectify fluid loss and or top up<br>Re-tension belt<br>Renew pump<br>Set to specification<br>Secure connection and bleed air out<br>Renew pump<br>Renew pump<br>Renew reservoir<br>Renew rack<br>Renew rack<br>Set to specification<br>Renew upper column |
| Heavy on one side                           | Faulty rotary valve or seal   | Renew rack  |
| Heavy when steering rapidly                 | Drive belt slack (V12)?<br>Engine idle speed too low<br>Pump drive loose (6cyl)<br>Air in system due to loose connection<br>Pump shaft seal faulty (fluid loss)<br>Delivery pressure or flow too low  | Retension belt<br>Reset idle speed<br>Renew pump<br>Secure connection and bleed air out<br>Renew pump<br>Renew pump   |
| Vague feel about center                     | Fluid level low?<br>tire pressures high<br>Air in system due to loose connection<br>Stiff or seized steering joint<br>Rack damper too tight<br>Castor or tracking error<br>Lower column over extended   | Rectify fluid loss and or top up<br>Set to specification<br>Secure connection and bleed air out<br>Test and renew faulty joint<br>Renew rack<br>Check geometry and rectify if required<br>Set to specification  |
| Knocking / vibration felt at steering wheel | Fluid level low?<br>Air in system due to loose connection<br>Pump shaft seal faulty (fluid loss)<br>Rack damper loose<br>Pinion bearing faulty<br>Rack or column fixings loose<br>Rack mounting bracket loose<br>Rack mounting bush loose<br>Free play in column assembly   | Rectify fluid loss and or top up<br>Secure connection and bleed air out<br>Renew pump<br>Renew rack<br>Renew rack<br>Tighten to specification<br>Renew rack<br>Renew rack<br>Check and rectify as required  |

10



## 10.4.3 Diagnostic chart 2

| Trouble  | Cause  | Remedy  |
|--|--|---|
| Play at steering wheel                                     | <ul style="list-style-type: none"> <li>  Rack damper loose</li> <li>  Pinion bearing loose</li> <li>  Worn intermediate shaft joint</li> <li>  Worn suspension joint</li> <li>  Loose lower column 'pinch' bolt</li> </ul>   | <ul style="list-style-type: none"> <li>Renew rack</li> <li>Renew rack</li> <li>Renew joint</li> <li>Renew joint</li> <li>Tighten to specification</li> </ul>  |
| Heavy when stationary                                      | <ul style="list-style-type: none"> <li>Transducer not closed</li> <li>Transducer not closed - ground short</li> <li>Transducer not closed - no feed voltage</li> <li>Transducer not closed - defective cable</li> <li>SCM defective</li> <li>Delivery pressure or flow too low</li> <li>Internal rack leakage</li> <li>tire pressures low</li> </ul>                         | <ul style="list-style-type: none"> <li>Inspect and check for debris</li> <li>Renew transducer*</li> <li>Investigate and repair</li> <li>Renew cable</li> <li>Renew module*</li> <li>Renew pump</li> <li>Renew rack</li> <li>Set to specification</li> </ul> |
| Excessively heavy when driving, stationary effort OK       | <ul style="list-style-type: none"> <li>Transducer open too early</li> <li>Transducer open too early, incorrect SCM type</li> <li>Transducer open too early, incorrect speedometer signal</li> <li>Rack 'reaction limitation valve' CLOSED or setting incorrect</li> </ul>  | <ul style="list-style-type: none"> <li>Renew transducer*</li> <li>Renew SCM*</li> <li>Renew speedometer transmitter*</li> <li>Renew rack</li> </ul>   |
| Too easy when driving, stationary effort OK                | <ul style="list-style-type: none"> <li>Transducer not open (no oil flow)</li> <li>Transducer not open, SCM faulty</li> <li>Transducer not open, incorrect speedometer signal</li> <li>Rack 'reaction limiting valve' OPEN or setting incorrect</li> <li>Low pressure pipe 'flattened' or restricted</li> <li>Blocked reservoir filter</li> <li>tire pressure high</li> </ul> | <ul style="list-style-type: none"> <li>Inspect and check for debris</li> <li>Renew SCM*</li> <li>Renew speedometer transmitter*</li> <li>Renew rack</li> <li>Renew pipe</li> <li>Renew filter</li> <li>Set to specification</li> </ul>                      |
| Effort not equal side to side from center                  | <ul style="list-style-type: none"> <li>Rack check valve leak</li> <li>Rotary valve blockage</li> <li>Incorrect lower column assembly, see 'Cyclic load variations'</li> </ul>  | <ul style="list-style-type: none"> <li>Renew rack</li> <li>Renew rack</li> <li>Rectify as required</li> </ul>   |
| Variation from heavy to easy when driving                  | <ul style="list-style-type: none"> <li>Incorrect speedometer signal</li> <li>Transducer cable / connection faulty or grounded</li> </ul>   | <ul style="list-style-type: none"> <li>Renew speedometer transmitter*</li> <li>Investigate and repair</li> </ul>  |
| Cyclic load variation at steering wheel - 2 per revolution | <ul style="list-style-type: none"> <li>Lower column universal joint fitting error</li> </ul>   | <ul style="list-style-type: none"> <li>Verify that the lower column assembly is correct for that drive. RH and LH assemblies MUST NOT be interchanged due to joint phase differences</li> </ul>   |
| Closely spaced cyclic load variation at steering wheel     | <ul style="list-style-type: none"> <li>Rack damper too tight</li> </ul>  | <ul style="list-style-type: none"> <li>Renew rack</li> </ul>  |

**Note:** Items marked \* should be validated using EDM test procedures.



## 10.4.4 Diagnostic chart 3

| Trouble  | Cause  | Remedy   |
|--|--|--|
| Hydraulic noise when turning lock to lock          | Fluid level low?   | Rectify fluid loss and or top up   |
|  | Air ingress at connections   | Check and tighten all connections to specification   |
|  | Air ingress through feed hose lining or skin                                       | Renew faulty 'O' rings or Dowty washers  |
|  | Air ingress at pump front seal   | Renew porous / damaged hoses   |
|  | Water contamination caused by fractured cooler pipe within engine coolant radiator | Renew pump   |
| Continuous pressure relief valve operation         | Pump starvation or cavitation caused by twisted or trapped feed hose               | Renew radiator. Flush and drain steering system twice minimum, check for noise and system performance (Pump is most susceptible to damage due to loss of lubrication and may have to be renewed) |
|  | Pump starvation caused by blocked filter   | Re-route or relieve pressure   |
|  | Worn pump  | Renew reservoir  |
| Continuous noise                                   | High pressure hose (pump to rack) damaged or restricted                            | Renew pump   |
|  | Fluid level low?   | Renew hose   |
|  | Drive belt loose (12cyl only)  | Rectify fluid loss and or top up   |
|  | Drive pulley loose   | Inspect for damage and renew as required   |
|  | Steering pump mounting (s) loose   | Tighten pulley to specification  |
|  | Drive 'dog' loose, slipping or incorrectly fitted (6cyl only)                      | Tighten to specification   |
| Hose or pipe fretting on body or chassis structure | Investigate & rectify as required  |  |
| Hosetwisted or restricted                          | Rectify routing  |  |
|  |  | Rectify routing  |



## 10.5 OUTER TRACK ROD BALL JOINT, RENEW

SRO 57.55.02

- Disconnect vehicle battery ground lead.
- Raise the front of the vehicle and remove the appropriate road wheel
- Slacken the track rod locknut but do not wind away from the ball joint (1 Fig. 1).

**Note:** Leave the lock-nut in its original position to initially locate the new ball joint.

- Remove the track rod ball joint nut (and discard) (2 Fig. 1) at the steering arm (3 Fig. 1).
- Using service tool JD 100 (1 Fig. 2), release the taper and remove the ball joint (2 Fig. 2).
- Fit the new track rod ball joint up to the lock-nut and secure at the steering arm with a new nut; tighten to specification.
- Fitting is the reversal of this procedure noting that the suspension should be fully settled prior to tracking adjustment.

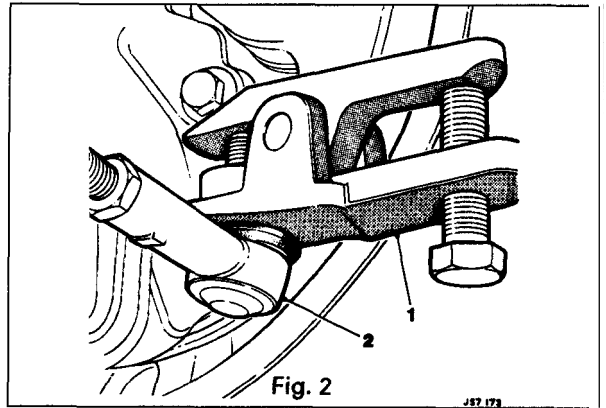
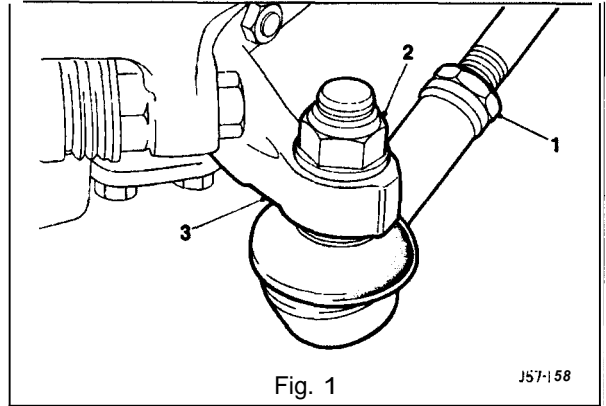

## 10.6 FRONT HUB ASSEMBLY, RENEW

SRO 60.25.01

## 10.7 FRONT HUB BEARING END FLOAT, CHECK AND ADJUST

SRO 60.25.12

## 10.8 FRONT HUB BEARING, RENEW

SRO 60.25.16

## 10.9 FRONT HUB OIL SEAL, RENEW

SRO 60.25.17

### Disassemble

- Disconnect vehicle battery ground lead.
- Support the vehicle at the front and remove the appropriate road wheel (s)
- Remove brake caliper and disc assemblies see SRO 70 10 10, section 12 for removal method only.

**Note:** Do not allow the caliper to hang by either harness or flexible hose.

**WARNING: DO NOT INHALE BRAKE PAD DUST, IT MAY DAMAGE YOUR HEALTH.**

- Prise of the hub grease cap (1 Fig. 3). Remove and discard cotter pin (2 Fig. 3), pull off castellated nut retainer (3 Fig. 3). Remove the hub nut and bearing washer. Carefully remove the hub assembly (4 Fig. 3) from the stub axle.
- Hub oil seal. Prise the original seal from the spigot and discard.
- Remove all traces of grease and dirt from the stub axle and back plate.
- Lightly lubricate the stub spigot (to ease assembly of the seal) and assemble the seal to the spigot using special tool JD 179 (Fig. 4).

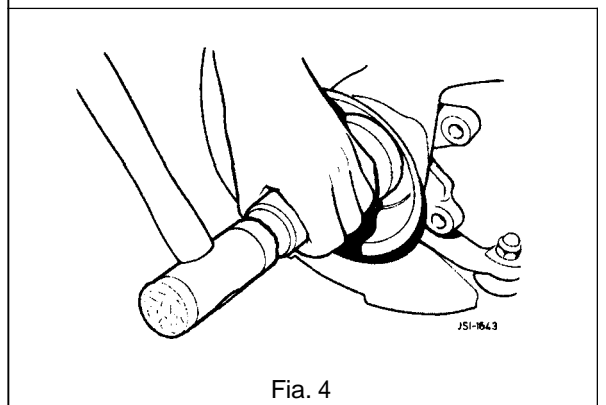
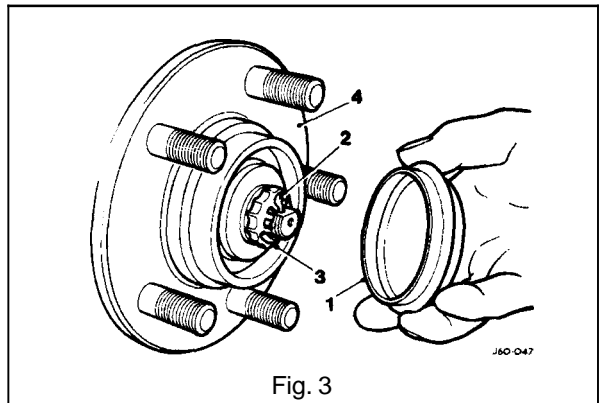





- Pack the annular gaps of the oil seal lips with grease.  
Ensure that the hub inner seal diameter is free of debris or damage and is lightly lubricated prior to assembly.
- **Bearing.** Wash the hub assembly thoroughly and 'drift' the affected bearing cup(s) from the hub.

**Note:** Only replace complete bearings, never cup or race in isolation.

- Hub. At this point the hub may be renewed if required.

## Assembly

- **Bearing.** Assemble the inner bearing track to the hub using service tool **18G 134** and adaptor JD 550 - 5 / 1.  
Assemble the outer bearing cup to the hub using service tool **18G 134** and adaptor JD 550 - 5 / 2.  
Pack each race with approximately 4 ml of grease and position the inner race onto the stub axle.  
Apply a smear of grease to hub inner surfaces and bearing cups. Assemble the hub to the stub axle followed by outer race, bearing washer and hub nut.

**Note:** It is not necessary to fill the hub cavity with grease, merely protect from corrosion with a coat of lubricant. 'Seat' the bearings by slightly tightening the hub nut whilst rotating the hub. Do not apply load without rotation.

- **Endfloat.** Set a Dial Test Indicator (DTI) as shown in Fig. 1 and adjust the hub nut to achieve the correct end float. As the adjustment is made, continually load the hub axially in both directions.
- Without disturbing the endfloat setting, fit the castellated nut retainer so that it aligns with both hub nut and stub axle drilling.
- Secure nut retainer using a new cotter pin.
- Assembly and fitting is the reversal of this procedure noting that; all fixings **MUST** be tightened to specification and operation of the braking system verified.

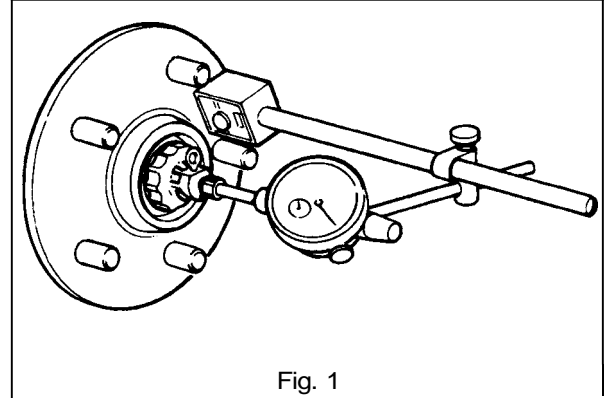



**SECTION CONTENTS**

| <b>Sub-Section</b> | <b>Title</b>   | <b>SRO</b> | <b>Page</b> |
|--------------------|--|------------|-------------|
| I to IV            | Preliminary Pages  |            | i           |
| 11.1               | Introduction   |            | 1           |
| 11.2               | Front Suspension. Description                            |            | 1           |
| 11.3               | Rear Suspension, Description                             |            | 2           |
| 11.4               | Diagnosis & Testing                                      |            | 3           |
| 11.4.1             | Diagnosis & Testing. Tire Wear                           |            | 3           |
| 11.4.2             | Diagnosis & Testing. Vibration & Roughness               |            | 3           |
| 11.4.3             | Diagnosis & Testing. Front End Inspection                |            | 4           |
| 11.4.4             | Diagnosis & Testing. Upper / Lower Ball Joint Inspection |            | 4           |
| 11.4.5             | Diagnosis & Testing. Damper Inspection                   |            | 4           |
| 11.4.6             | Diagnosis & Testing. Rear Suspension Inspection          |            | 5           |
| 11.4.7             | Diagnosis & Testing. Vehicle Inspection                  |            | 5           |
| 11.4.8             | Diagnosis & Testing. Diagnostic Procedure Chart          |            | 6           |



## 1. SERVICE TOOLS & EQUIPMENT

| Illustration    | Jaguar Number | Description  | Notes |
|-----------------|---------------|--|-------|
|                 | JD1D          | Hub Remover Rear Suspension                          |       |
| Not illustrated | JD 60         | Wishbone Upper Bush Remover/<br>Replacer             |       |
|                 | JD100         | Remover Steering Arm and Swivel<br>Hub Ball Pins     |       |
|                 | JD115         | Spring Compressor Front Suspension                   |       |
|                 | JD133         | Camber Tie Down Link (Front)                         |       |
|                 | JD135         | Remover/Renewer Front Damper<br>Lower Bush           |       |
|                 | JD143         | Remover/ Renewer Suspension<br>Bushes (Main Tool)    |       |
|                 | JD143-1       | Adaptor Ring Front Sub Frame Rear<br>Bushes          |       |
|                 | JD143-2       | Anvil adapter  |       |
|                 | JD143-3       | Adaptor Remover/ Renewer<br>Suspension <b>Bushes</b> |       |

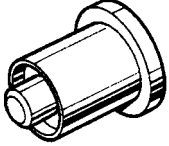
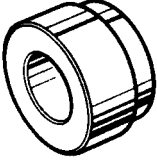
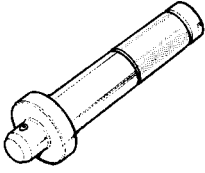
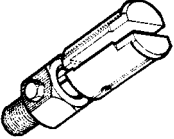
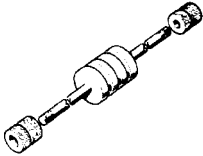

## 1. SERVICE TOOLS & EQUIPMENT (continued)

| Illustration  | Jaguar Number | Description  | Notes |
|---|---------------|--|-------|
|    | JD143-4       | Adaptor Remover/ Renewer Suspension Bushes (Bottom Front Wishbone Inner) |       |
| Not illustrated   | JD199         | Spring Compressor Rear Suspension  |       |
| Not illustrated   | JD199-1       | Damper Retaining Tie Rear Suspension                                     |       |
|    | JD 550-6      | Adaptor Replacer Rear Hub Pivot Bearing Cup                              |       |
|    | 18G 134       | Driver Handle  |       |
|   | 18G 284 AAH   | Adaptor Remover Main Shaft Pilot Bearing Outer Track                     |       |
|  | 18G 284       | Impulse Extractor (slide Hammer) UNF. Basic Tool                         |       |

| Fixing       | Tightening Torque (Nm) |
|--------------|------------------------|
| To be issued |                        |

| Description               | Uses   | Notes |
|---------------------------|--|-------|
| LM Multi - purpose grease | Lower damper bolt<br>Wishbone to crossmember fulcrum shaft |       |
| Molib Alloy P1907 No1     | Stabilizer mounting bushes & rear damper top guide bush    |       |
| Molykote 111              | Caliper to carrier bolts / guide pins                      |       |



| Application                                      | Specification   |
|--|-----------------|
| Camber angle front suspension                    | +0.3° to - 0.8° |
| Caster angle (Same setting each side of vehicle) | 3.0° to 6.0°    |
| Wheel alignment                                  | 5' Toe-in ± 10' |

Note: Geometry is to be checked/set using the mid-laden setting-links. Setting height should correspond to the following dimensions:

Front 153 ± 5mm under front crossbeam (AJ16)

Front 143 ± 5mm under front crossbeam (V12)

Rear 160 ± 5mm under rear edge of 'A' frame



## 11.1 INTRODUCTION

This section describes the front and rear suspension systems, and also covers diagnostic procedures.

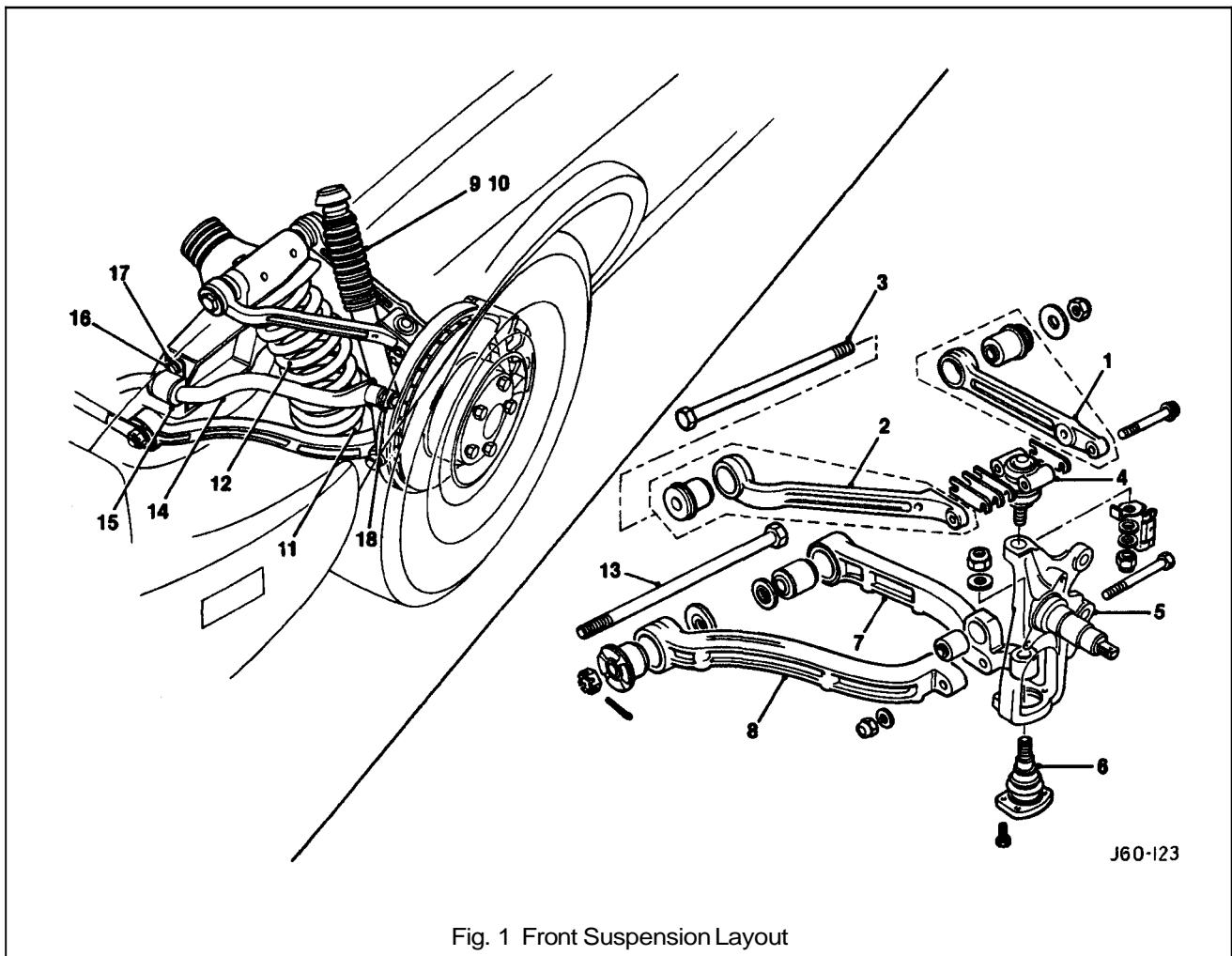

Fig. 1 Front Suspension Layout

## 11.2 FRONT SUSPENSION, DESCRIPTION

The upper rear wishbone (1 Fig. 1) and the upper front wishbone (2 Fig. 1) are pivoted on the upper fulcrum bolt (3 Fig. 1), passing through the front cross beam assembly. They are also fitted via an upper ball joint assembly (4 Fig. 1) to a vertical link accommodating the stub axle (5 Fig. 1), whereas the vertical link is fitted via a lower ball joint assembly (6 Fig. 1) to the lower wishbone assembly.

The lower wishbone assembly comprises a lower rear wishbone (7 Fig. 1), lower front wishbone (8 Fig. 1), damper (9 Fig. 1) (incorporating damper bush 10 Fig. 1) and spring pan (11 Fig. 1) supporting the road spring (12 Fig. 1). The lower wishbone assembly is pivoted on the bushed lower fulcrum shaft (13 Fig. 1) which also passes through the cross beam assembly.

Both independent front suspension assemblies are linked by a stabilizer bar (14 Fig. 1) which is secured to the cross member using a fixing arrangement of mounting rubbers (15 Fig. 1), clamps (16 Fig. 1), nuts, bolts, washers (17 Fig. 1) and two link arm assemblies (18 Fig. 1). Each link arm assembly is fitted to one end of the stabilizer bar and to one end of the lower front wishbone using a fixing arrangement of bolts, washers and self locking nuts.

All suspension loads, except the damper, are fed into a pressed steel crossbeam which is isolated from the body by rubber bushes. This mounting method allows the necessary amount of compliance.

The degree of caster is adjustable via shims positioned on either side of the upper ball joint assembly but camber is factory set and is not adjustable. The vertical link and the steering arm form a single forging. Cast iron hubs rotate on twin tapered roller bearings.

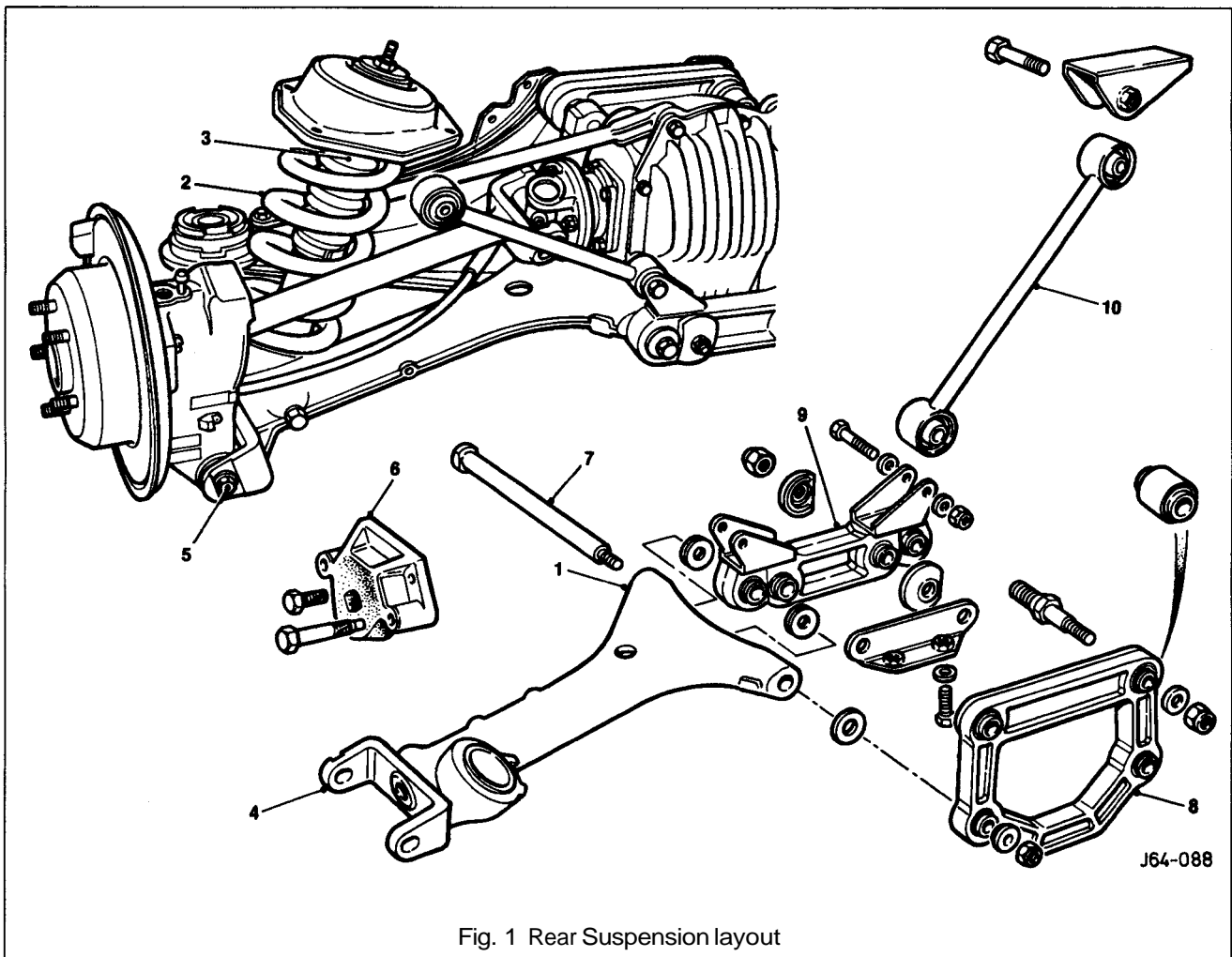

Fig. 1 Rear Suspension layout

### 11.3 REAR SUSPENSION, DESCRIPTION

The vehicle's rear suspension layout features a cast wishbone complete with integral lower spring pan (1 Fig.1) supporting the independently mounted damper (2 Fig.1) and road spring (3 Fig.1).

The lower wishbone arm is bolted to the hub carrier (4 Fig.1) by means of a pivot bolt (5 Fig.1), allowing for toe-in adjustment. When the pivot bolt is seated correctly in the plate located on the wishbone arm, it has a small clearance at the sides but full clearance at the top and bottom.

Rotation of the bolt head, with eccentric constrained between the vertical faces, causes the bolt shank to be moved in the horizontal plane, thus displacing the hub carrier and effecting wheel alignment adjustment.

The snubber (6 Fig.1) positioned above the hub carrier, prevents this from touching the vehicle body.

The hub carrier/wishbone assembly, is pivoted on the wishbone fulcrum bolt (7 Fig.1) and is then secured by a nut and washer fixing arrangement to the pendulum assembly (8 Fig.1) and the wishbone tie assembly (9 Fig.1). The differential strut (10 Fig.1) is fastened to the wishbone tie assembly and to a bracket, welded to the vehicle body. Both, the pendulum and the wishbone tie assembly are fitted to the differential unit which is mounted on to a mounting frame and a rear frame carrier.

The supercharged vehicle (manual only), the XJ12 and the sport versions are equipped with a rear stabilizer bar, a differential monostrut instead of two single struts, a modified wishbone tie and two stabilizer bar drop links which are seated on the lower wishbone cast bosses.



## 11.4 DIAGNOSIS AND TESTING

### 11.4.1 Tire Wear

Tires should be inspected as abnormal or excessive wear may be caused by incorrect wheel alignment, wheel/tire imbalance, or incorrect tire pressure.

### 11.4.2 *vibration and Roughness*

Vibration, roughness, and shimmy conditions may be caused by excessive tire or wheel runout, worn or cupped tires, or wheel and tire unbalance.

Most of these conditions are due to irregularities in the road surface, hence driving the vehicle on different types of road surface will often indicate the cause of the condition.

Do not automatically suspect the tires when attempting to diagnose a vibration concern as other sources of vibration may include:

- Loose or worn wheel bearings.
- Loose or worn suspensions or steering components.
- Worn or damaged drive shaft slip yoke joint.
- Front disc rotor runout.
- Loose engine or transmission supports.
- Engine driven accessories.
- Driveline alignment.

Before investigating any other vibration concerns, a road test and a customer **interview** (if possible) should be carried out. This can provide much of the information needed to find the source of vibration.

Drive the vehicle on a road that is preferably smooth and free of undulation and if vibration is apparent note, the speed at which the vibration occurs, **what type** of vibration occurs in each speed range (mechanical or audible), **how the vibration** is affected by changes in vehicle speed, engine speed and engine torque, and the type of vibration sensitivity (torque sensitive, vehicle speed sensitive, or speed sensitive).

Some of the condition terms used when describing sources of vibration are explained as follows:

- **Torque Sensitive**  
This condition can be improved or worsened by accelerating, decelerating, coasting, maintaining a steady vehicle speed and application of engine torque.
- **Vehicle Speed Sensitive**  
This means that the vibration always occurs at the same vehicle speed and is not affected by engine torque, engine rpm, or transmission gear selection.
- **Engine Speed Sensitive**  
This means that the vibration occurs at varying vehicle speeds when a different transmission gear is selected. It can sometimes be isolated by increasing or decreasing engine speed with the transmission in 'NEUTRAL', or by stall testing with the engine in gear. If the condition is **engine-sensitive**, the condition is not related to tires. If the road tests indicate that the vibration is related to the tires or wheels, use a 'Tire Wear Diagnosis Chart' to investigate the cause of concern. Should the road test indicate that there is tire whine, but no shake or vibration, the noise originates from the contact between the tire and the road surface.





## 11.4.3 Front End Inspection

Do not check and adjust front wheel alignment without carrying out the following inspection for front end damage and wear:

- Check for specified air pressure in all four tires.
- Raise front of vehicle off the floor; grasping upper and lower surface of the tire, shake each front wheel to check for worn bearings.
- Check front suspension lower arm ball joint and mounts for looseness, wear and damage.
- Check brake caliper mountings.
- Check steering gear mountings and all steering linkages for looseness.
- Renew parts if necessary.
- Grasp upper and lower surface of tire and shake each wheel to check wheel bearing end play.
- Check the action of the front dampers and the condition of their attachments, as sticking or binding front dampers may not allow the vehicle to settle in to a normal level position, possibly affecting the front-wheel alignment.

**Note:** Front wheel bearings are adjustable (0.001 to 0.003 in. endfloat).

## 11.4.4 Upper/ Lower Ball Joint Inspection

- Check the wheel bearings.
- Inspect the front suspension upper joint and renew front suspension lower wishbone if needed.
- Raise vehicle and position floor jacks beneath the front suspension lower wishbone.
- Grasp the lower edge of the tire and move the wheel in and out.
- While moving the wheel, observe the upper and lower wishbone.
- Movement between the vertical links and the wishbones indicates abnormal ball joint wear.
- Renew ball joints.
- Check the front wheel bearings.
- Check for excessive play and wear.

## 11.4.5 Damper Inspection

**Note:** The gas-pressurized hydraulic front dampers are not serviceable, adjustable or refillable.

- Verify that all attachments of the suspension components and the front dampers are tight. Renew any front damper that has a damaged integral lower mounting bushing.
- Check front dampers for external damage.
- Check for oil leakage and vehicle sag.

### ○ Oil Leak

Leakage is the condition in which the entire damper body is covered with oil and from where it will drip on to the pavement. Due to correct damper lubrication a light film of oil (weepage) can usually be seen on the upper portion of the damper.

Should there be any leakage, ensure that the fluid does not originate from sources other than the front damper. Renew worn or damaged dampers.

### ○ Vehicle Sag

Renewing front dampers will not correct the problem of vehicle sag, as basically this is controlled by the spring units.



## 11.4.6 *Rear Suspension Inspection*

- Check for evidence of fluid leaks on rear dampers.
- Check damper operation.
- Check condition of rear wishbone bushings and rear suspension strut bushings.
- Renew damaged or worn components.

## 11.4.7 *Vehicle Inspection*

- Check all tires for correct inflation pressure.
- Check tire condition to confirm correct front end alignment, tire balance and overall tire conditions such as separation or bulges.
- Check the vehicle attitude for evidence of possible overload or sagging.
- Check luggage compartment area.
- Road test vehicle to confirm customer's concern.



## 11.4.8 Diagnostic Procedure

| Condition                                      | Possible Cause  | Action  |
|--|---|---|
| <b>Wander/Pull/Drift</b>                       | Side-to-side difference in caster.<br><br>Tire pressure<br>Steering gear or linkage worn or defective.<br>Tire <b>conicity</b>  | Check the alignment and if incorrect, adjust the caster if needed. Inspect components for wear or damage.<br>Check for abnormal loading.<br>Check steering system<br>Inspect tire for excessive wear.<br>Check and adjust the tire air pressure.<br><b>Note: Excessively worn or uneven tires can cause pull/drift.</b>   |
| <b>Hard steering</b>                           | Power steering gear or linkage worn, damaged, or incorrect adjusted.<br>Wear of front suspension <b>lower/upper</b> wishbone ball joints.   | Check steering system.<br><br>Renew ball joints.  |
| <b>Brake pull</b>                              | Unequal tire pressure.<br><br>Brake system <b>fault(s)</b>  | Inflate the tires to correct and uniform pressure.<br>Check the brakes.   |
| <b>Shimmy</b>                                  | <b>Wheel/tire imbalance or runout.</b><br>Damaged tires, unbalanced or damaged wheels.<br><br>Incorrect wheel alignment.<br>Steering system malfunction<br>Front damper malfunction.<br>Loose front damper mounting.<br>Damaged front suspension upper or lower ball joints.<br>Damaged or worn sub-frame to body mounting.<br>Damaged or worn stabilizer bar insulators.<br>Damaged or worn stabilizer bar link.<br>Damaged or worn wheel bearing. | Check wheels and tires.<br>Check the tires and renew if necessary.<br>Balance the wheels if necessary.<br><br>Adjust wheel alignment.<br>Check steering system.<br>Renew front damper if necessary.<br>Tighten front damper mounting.<br><br>Renew upper and lower ball joint.<br><br>Renew rear suspension bushing.<br>Renew insulators.<br>Renew link.<br>Renew/adjust wheel bearing. |
| <b>Dog-Tracking</b>                            | Rear suspension damage.   | If the caster is uniform, check and compare the wheelbase at the right and left sides. If different, inspect the suspension components for wear and damage.   |
| <b>Bump steer (unequal side-to-side)</b>       | Worn steering gear mounting bracket housing insulators.   | Renew bracket housing insulators.   |
| <b>Sawtooth pattern or excessive tire wear</b> | Excessive toe-in (high edges inboard) or toe-out (high edges outboard).   | Check and adjust toe-in.  |
| Uneven tire wear (outer or inner shoulder)     | Incorrect tire pressure.<br>Excessive toe.<br>Excessive positive or negative camber.  | Correct tire pressure.<br>Check toe and adjust if needed.<br>Check the camber and if incorrect inspect the related components for wear or damage.   |
| <b>Front/rear suspension noises</b>            | Loose/missing front dampers and front damper bolt to front suspension lower wishbone.   | <b>Tighten/renew</b> damper bolts.<br>Inspect wheel hubs.   |



## 11.4.8 Diagnostic Procedure (continued)

| Condition                               | Possible Cause  | Action  |
|---|---|---|
| Body 'rolls'                            | Weak front stabilizer bar.<br>Damaged or worn lower wishbone stabilizer bar insulator.<br>Damaged or worn stabilizer bar link<br>Damaged or worn rear suspension wishbone bushing.<br>Damper malfunction.<br>Worn or deteriorated rear stabilizer bar <b>bushing(s)</b> . (supercharged, sports and <b>XJ12</b> only)   | Renew front stabilizer bar.<br><br>Renew insulators.<br>Renew link.<br><br>Renew bushing.<br>Renew damper if necessary.<br><br>Renew Bushing  |
| Body leans                              | Damaged or worn rear wishbone bushing and weak springs.<br>Worn or deteriorated rear stabilizer bar <b>bushing(s)</b> . (supercharged, sports and <b>XJ12</b> only)   | Renew bushings and springs.<br><br>Renew Bushings.  |
| Poor ride comfort                       | Front or rear damper malfunction.<br>Weak <b>spring(s)</b>  | Renew dampers.<br>Renew springs.  |
| General driving instability             | Damaged tires or unbalanced wheels.<br>Incorrect wheel alignment.<br>Steering system malfunction.<br>Damaged front suspension lower and upper ball joints.<br>Damaged or worn sub-frame to body mounting.<br>Damaged or worn stabilizer bar link<br>Damaged or worn lower wishbone stabilizer bar insulator.<br>Weak <b>spring(s)</b><br>Worn or deteriorated rear stabilizer bushing ( <b>s</b> ) (supercharged, sports and <b>XJ12</b> only)                                      | Check the tires.<br>Adjust the wheel alignment.<br>Check steering system.<br><br>Renew ball joints.<br><br>Renew bushing.<br>Renew link.<br><br>Renew insulator.<br>Renew springs.<br><br>Renew bushing |
| Steering wheel does not return properly | Damaged tires or unbalanced wheels and incorrect tire pressure.<br>Incorrect wheel alignment.<br>Steering system malfunction.<br>Damaged front suspension lower and upper ball joints.  | Check tires.<br>Adjust the wheel alignment.<br>Check steering system.<br><br>Renew ball joints.   |
| Steering wheel pulls to one side        | Incorrect tire pressure.<br>Damaged front suspension lower and upper ball joints.<br>Braking system malfunction.<br>Steering system malfunction.<br>Damaged or worn sub-frame to body mounting.<br>Damaged tires, unbalanced wheels and incorrect tire pressure.  | Check and correct tire pressure.<br><br>Renew ball joints.<br>Check brakes.<br>Check steering system.<br><br>Renew bushing.<br><br>Check tires.   |
| Abnormal noise from suspension system   | Poor lubrication /wear of wheel bearing.<br>Wear of front suspension lower and upper ball joints.<br>Damaged or worn front stabilizer bar<br>Damaged or worn stabilizer bar link.<br>Damaged or worn stabilizer bar bracket.<br>Looseness of suspension connections.<br>Damaged or worn rear wishbone bushing.<br>Front and rear damper malfunction.<br>Weak <b>spring</b> . Worn or deteriorated rear stabilizer bushing ( <b>s</b> ). (supercharged, sports and <b>XJ12</b> only) | Renew wheel bearing.<br><br>Renew ball joints.<br>Renew stabilizer bar.<br>Renew link.<br>Renew bracket.<br>Tighten connections.<br>Renew bushing.<br>Renew dampers.<br><br>Renew bushing               |





SECTION CONTENTS

| <b>Sub-Section</b> | <b>Title</b>   | <b>SRO</b>    | <b>Page</b> |
|--------------------|--|---------------|-------------|
| <i>i to iv</i>     | <i>Preliminary Pages</i>                               |               | <i>i</i>    |
| 12.1               | Anti-Lock Braking System (ABS) General Description     |               | 12.1        |
| 12.1.2.            | Anti-lock Braking/ TractionControl Operation           |               | 12.3        |
| 12.1.3             | Anti-lock Braking Operation                            |               | 12.4        |
| 12.1.4             | Actuation Components                                   |               | 12.5        |
| 12.1.5             | ABS Components   |               | 12.6        |
| 12.1.6             | Calipers   |               | 12.7        |
| 12.1.7             | Parking Brake  |               | 12.9        |
| 12.1.8             | Wheel Speed Sensors                                    |               | 12.11       |
| 12.1.9             | Hydraulic Operation – ABS CM                           |               | 12.12       |
| 12.1.10            | Hydraulic Operation – ABS /TC CM                       |               | 12.14       |
| 12.2               | Fault Diagnosis and Testing                            |               | 12.16       |
| 12.3               | Brake Fluid Level Check                                |               | 12.18       |
| 12.4               | Brake System Bleeding                                  |               | 12.19       |
| 12.4.1             | System Bleeding – General Instructions                 |               | 12.19       |
| 12.4.2.            | System Bleeding After Brake Fluid Renewal              |               | 12.19       |
| 12.4.3             | System Bleeding After Tandem Master Cylinder Renewal   |               | 12.19       |
| 12.4.4.            | System Bleeding After Hydraulic Control Module Renewal |               | 12.20       |
| 12.4.5.            | Bleeding After Renewal of Caliper                      |               | 12.20       |
| 12.5               | General Fitting Instructions                           |               | 12.21       |
| 12.5.1             | General Fitting Instructions, Brake Fluid              |               | 12.21       |
| 12.5.2.            | General Fitting Instructions, Hoses                    |               | 12.21       |
| 12.5.3             | General Fitting Instructions, Pipes                    |               | 12.21       |
| 12.6               | Rear Wheel Speed Sensor – Renew                        | 70.60.04      | 12.22       |
| 12.7               | Hydraulic Control Module – Renew                       | 70.60.18 / 19 | 12.23       |
| 12.8               | Pressure Conscious Reducing Valves                     | 70.60.21      | 12.25       |
| 12.9               | ABS / TC CM – Renew                                    | 70.60.02 / 20 | 12.26       |

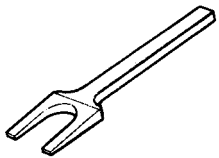
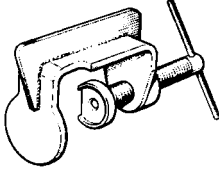
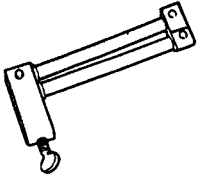

## 1. SERVICE TOOLS & EQUIPMENT

| Illustration  | Jaguar Number | Description                     | Notes |
|---|---------------|---------------------------------|-------|
|  | JD.142        | Parking brake cable remover     |       |
|  | 186.672       | Replacer disc brake piston seal |       |
|  | 6947017       | Brake hose clamp, Girling       |       |
| not illustrated   | JDS.9013      | Brake pedal hold down tool      |       |

## II. TORQUE TIGHTENING SPECIFICATIONS

| Fixing                                   | Tightening Torque (Nm) |
|--|------------------------|
| Vacuum booster to pedal box              | 21 - 29                |
| Tandem master cylinder to booster        | 21 - 29                |
| Hydraulic module to module bracket       | 18 - 26                |
| Caliper guide pins                       | 25 - 35                |
| Caliper to vertical link                 | 120 - 160              |
| Caliper to hub carrier                   | 54 - 66                |
| Pipe connectors to hydraulic module: M12 | 15 - 19                |
| M10                                      | 12 - 16                |

## 11. SERVICE MATERIALS

| Description  | Uses                              | Notes |
|--------------|-----------------------------------|-------|
| Molykote 111 | Caliper to carrier securing bolts |       |

## IV. SERVICE DATA

|                              |                          |
|------------------------------|--------------------------|
| Front brake disc run out     | 0.101 mm (0.004 in) max. |
| Front brake disc parallelism | 0.0127mm (0.0005in) max. |
| Rear brake disc run out      | 0.101 mm (0.004 in) max. |
| Rear brake disc parallelism  | 0.0127mm (0.0005in) max. |



## 12.1 ANTI-LOCK BRAKING SYSTEM (ABS), GENERAL DESCRIPTION

The anti-lock braking system (ABS) components are combined with a hydraulic booster and tandem master cylinder (TMC) to provide a two-circuit braking system. The anti-lock braking system comprises the following components:

- Four inductive wheel speed sensors, hub end mounted
- ABS warning light
- Hydraulic module.

The hydraulic module consists of an electric motor driven pump, two low pressure accumulators, valve block and an ABS electronic control module.

**Note:** Electronic control modules for vehicles without traction control are designated ABS CM. Control modules for vehicles with traction control are designated ABS /TC CM.

The valve block houses solenoid operated valves which are activated by voltage signals from the control module. The signals are generated using wheel speed information received from the wheel speed sensors.

For vehicles without traction control the valves operate on three circuits, two front and one rear, as necessary to prevent wheel locking during braking. Brake pressure is modulated individually at the front wheels and collectively at the rear. Rear wheel control operates on a 'select low' principle i.e. locking in either wheel is sensed, and controlled brake pressure is applied to both wheels.

For vehicles with traction control the valves operate on four circuits. During ABS control the rear wheel are controlled on a 'select low' principle (as above), but during traction control operation the rear wheels are controlled individually.

**Note:** Functional and diagnostic information for the ABS CM and the ABS / TC CM is contained in the Electrical Diagnostic Manual (EDM), Section 12.

### **ABS Warning lamp / Traction Control Warning lamp / Fluid level Indicator**

The ABS and traction control warning lamps, mounted in the instrument panel, indicate a fault in the ABS or traction control. These systems are inhibited or disabled when the lamps are lit, although conventional braking is unaffected.

When the ignition is switched on, an ABS self test is initiated. During this test, the ABS and traction control warning lamps are lit for approximately 1.7 seconds and then extinguish. A fault is indicated if the warning lamps remain lit or come on whilst the vehicle is being driven.

**Note:** The ABS self test is masked by the 5 second lamp test initiated when the ignition is switched on.

The fluid level indicator lamp, mounted in the instrument panel, is lit when the brake fluid falls below the minimum mark on the brake fluid reservoir.

### **ABS / Traction Control - Inhibit / Disable**

Fault conditions are detected by the ABS / TC CM which disables the ABS and traction control until the fault is rectified. The ABS and traction control warning lights on the instrument pack remains lit whilst a fault exists. The system will be disabled when the following conditions occur:

- Valve failure
- Sensor failure
- Main driver failure (internal ABS /TC CM fault)
- Redundancy error (internal ABS / TC CM fault)
- Overvoltage/ undervoltage
- Pump motor failure.
- Throttle valve actuator motor failure (traction control vehicles only).
- Throttle valve actuator potentiometer failure (traction control warning light only).





The input frequency from each wheel speed sensor signal is translated by the ABS / TC CM, into a comparable wheel speed. The ABS / TC CM continually monitors the system. False wheel speed information, such as sudden speed changes in excess of 20 km / h or excessive speeds, are detected as a 'sensor malfunction'. The ABS / TC CM reacts to fault conditions in the following ways:

**Inhibit** – ABS / traction control is inhibited until the sensed speed returns to within an acceptable limit, whereupon ABS / traction control is restored. Conventional braking is unaffected. Depending on vehicle speed the ABS / traction control warning lights may come on.

**Disable** – ABS / traction control is Disabled (switched off) and the ABS / traction control warning lights come on. The system will not be restored until the engine is switched off and restarted or the fault has been rectified. After the system has been disabled, the warning lamps remain on until the vehicle has reached a speed of 20 km / h during the first ignition cycle after fault rectification.

Full diagnostic information for the ABS / TC CM is given in the Electrical Diagnostic Manual (EDM), Section 12.



## 12.1.2. Anti-lock Braking/ Traction Control Operation

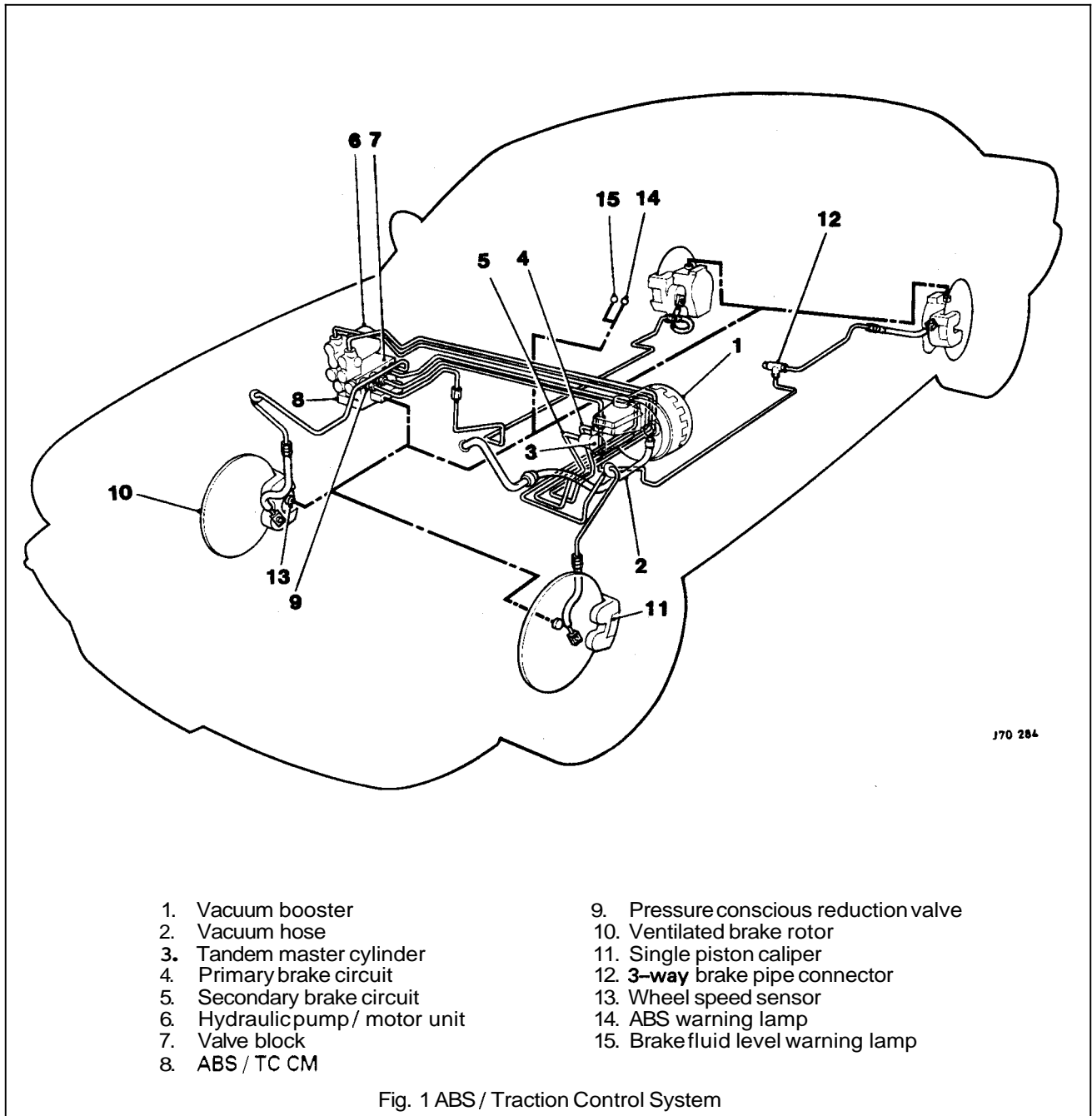

The vacuum booster (see Fig. 1) is mounted on the brake pedal box and secured by three bolts. Brake pedal force is increased by the vacuum booster which activates the Tandem Master Cylinder (TMC) intermediate piston. Brake fluid is supplied to the pump inlet ports on two separate circuits. The primary circuit supplies the front brakes whilst the secondary circuit supplies the rear brakes.

The rear wheels are controlled collectively on a 'select-low' principle during ABS operation. During traction control, separate circuits allow individual control of the rear wheels. To facilitate this the valve block has four outlet ports.

The ABS / TC CM is integrated with the valve block. The pump, motor, valve block and control module are supplied as a unit and are non-sewiceable. Faulty units must be renewed as a whole.

Both front and rear brakes on all vehicles are fitted with single piston caliper assemblies. Ventilated brake rotors, with provision for parking brake shoes at the rear, are fitted all round.



Pressure conscious reduction valves (PCRVs) are fitted between the outlet of the valve block and the rear brake circuit to optimize. The valves are fitted to prevent over braking due to the increased size of the rear brake calipers which are required for traction control. Up to a threshold of 15 bar, brake pressure to the front and rear brakes is equal. Above 15 bar the PCRVs reduce pressure to the rear brakes to provide a closer balance between front and rear brakes and optimize road adhesion.

Wheel speed sensors are fitted to all wheels to transmit wheel speed information to the control module. The module uses this information to modulate brake pressure during anti-lock braking or traction control.

## 12.13. Anti-lock Braking Operation

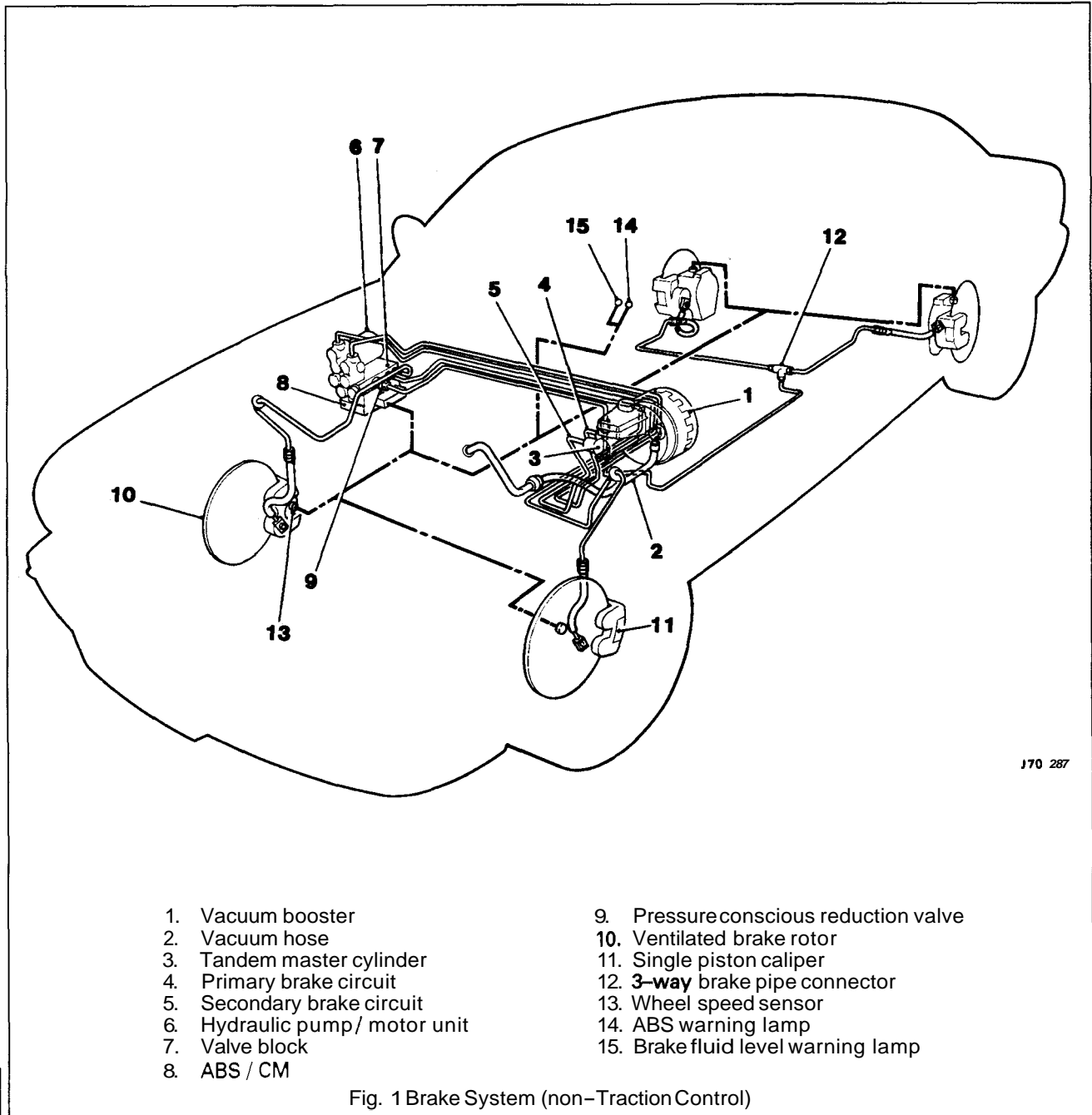

12

The rear brakes (see Fig. 1) are controlled collectively on a 'select-low' principle. Under ABS braking conditions, equal brake pressure is applied to both rear calipers, although only one wheel may have a tendency to lock.

The valve block has three outlet ports, Brake fluid volume is supplied equally to the rear brakes via the 3-way brake pipe connector.



## 12.1.4. Actuation Components

The vacuum booster (1 Fig. 1) is mounted on the brake pedal box and secured by three bolts. The TMC locates on two studs on the vacuum booster. Two lugs locate the fluid reservoir on the TMC and is secured by a split pin.

The vacuum is drawn from the inlet manifold. At the vacuum booster, the vacuum hose is connected to the vacuum chamber via an elbow connector. At the inlet manifold the vacuum hose connector is of the push-on quick-release type.

Applied pedal force is increased by the vacuum booster which actuates the intermediate piston of the TMC (2 Fig. 1). The boost ratio supplied by the vacuum booster is 6.5 : 1.

**Note:** The vacuum booster and the TMC are supplied as a unit but are individually serviceable.

The brake fluid reservoir (3 Fig. 1) is fitted with a fluid level indicator switch which opens when fluid level is low and lights the fluid level indicator Light.

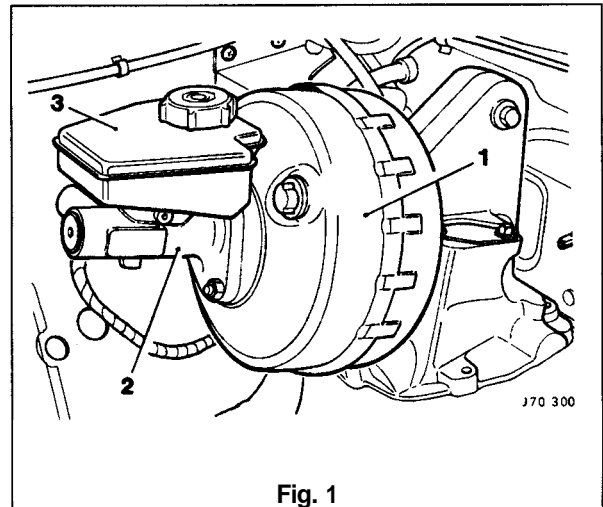

Fig. 1

## 12.1.5. ABS Components

### Hydraulic Module

The hydraulic module is located under the bonnet adjacent to the engine compartment firewall. It is secured within a steel mounting bracket at three securing points. All electronic and power connections are made through one cable loom connection.

The hydraulic pump (1 Fig. 1) is a reciprocating two-circuit pump in which one brake circuit is assigned to each pump circuit. The pump supplies adequate pressure and volume supply to the brake circuits under anti-lock braking conditions. The pump is driven by an electric motor (2 Fig. 1). The pump housing incorporates two low pressure accumulators and damping chambers for each brake circuit.

A modulator valve block (3 Fig. 1) incorporates the ABS CM or ABS / TC CM (4 Fig. 1). Vehicles with traction control are fitted with a throttle position actuator (5 Fig. 1), which is an electrical device controlled by the ABS / TC CM.

Valve blocks on vehicles without traction control comprise six solenoid valves, three normally open (NO) inlet valves and three normally closed (NC) outlet valves. These valve blocks have three outlet ports. Valve blocks on vehicles with traction control comprise nine solenoid valves, four NO inlet valves, four NC outlet valves and one special isolating valve. Fig. 2 shows a hydraulic module for vehicles with traction control. The valve block (2 Fig. 2) has four outlet ports (Individual control of the driven wheels).

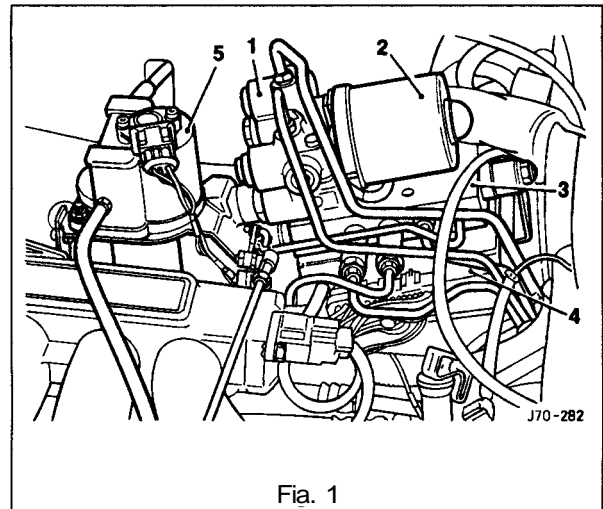

Fig. 1

### ABS CM, ABS / TC CM

The ABS CM or ABS TC / CM locates beneath the modulator valve block and is secured by two screws. The CM houses the solenoids which operate the inlet and outlet valves of the modulator valve block. When fitted, the valve stems locate in the CM mounted solenoids. There is no electrical connection between the CM and the modulator valve block. Fig. 3 shows an ABS TC / CM having nine solenoids.

The CM functions include the following:

- Providing control signals for the operation of ABS and traction control solenoid valves
- Calculating wheel speed from voltage signals transmitted by the wheel speed sensors
- Monitoring of all electrical components
- On Board Diagnostics (OBD): storage of possible failures in a non-volatile memory.

The signals from the four wheel speed sensors are independently processed by the ABS CM or ABS / TC CM, calculating numerical values which correspond directly to the wheel speed. These values are converted into control signals for pressure modulation during ABS control.

The ABS and traction control are continuously monitored, whilst the ignition is on, for possible faults and interruptions. If a fault is detected, the module deactivates the ABS and indicates this by lighting the ABS warning lamp. In a fault condition, conventional braking is unaffected. The module stores fault codes in a non-volatile memory which can be read via the OBD link.

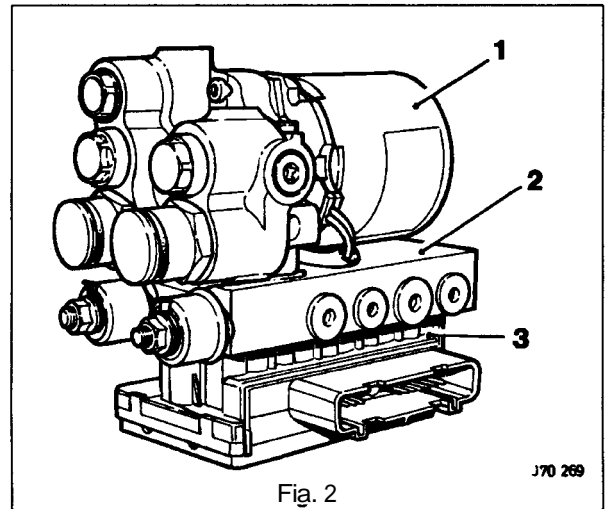

Fig. 2

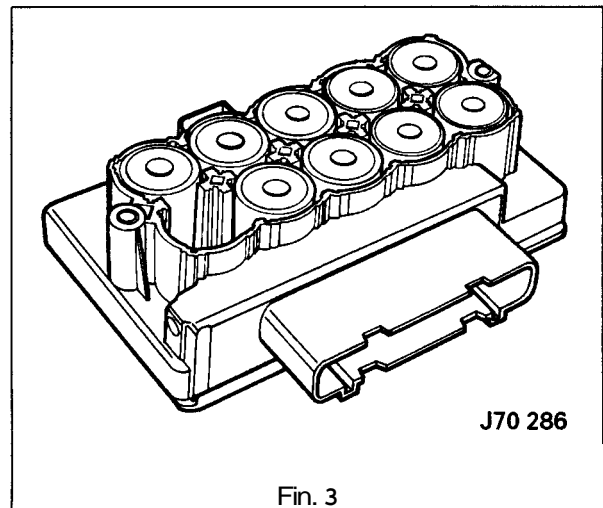

Fig. 3

**Note:** For electrical diagnostic information on the ABS / traction control systems, refer to EDM, Section 12.



## 12.1.6 Calipers

Both front and rear brakes on all vehicles are fitted with single piston caliper assemblies that act upon 28mm thick ventilated brake rotors (front brakes) and 20mm thick ventilated brake rotors/hubs (rear brakes). Rear ventilated brake rotors/hubs are fitted to cope with the increased demands brought about by traction control.

The brake rotors must be renewed when the minimum thickness specified below is reached:

- Front brake rotor - 27mm
- Rear brake rotor - 18.5mm.

On the front brakes (Fig. 1) two bolts secure the caliper carrier to the suspension vertical link.

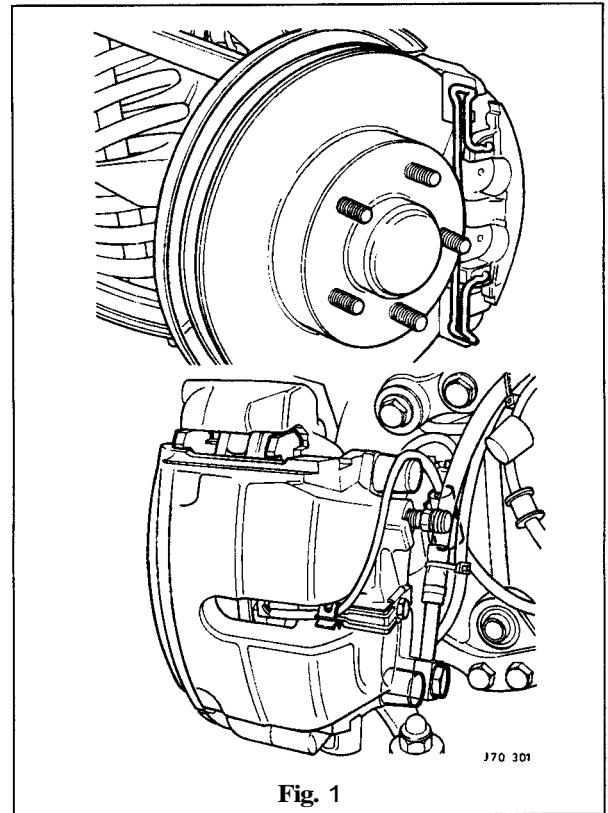

Fig. 1

On the rear brakes (Fig. 2) two bolts (wirelocked) secure the caliper carrier to the hub carrier.

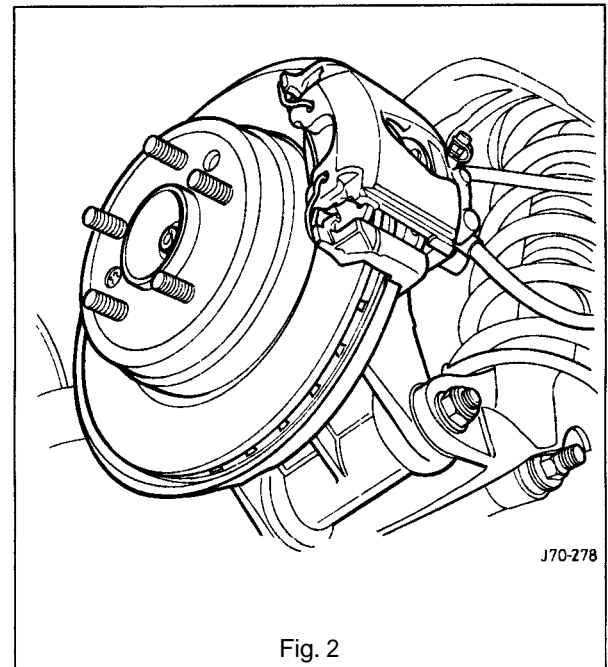

Fig. 2



The caliper (1 Fig. 1) is mounted on the carrier (2 Fig. 1) by means of two guiding pins (3 Fig. 1) and a caliper retaining clip (5 Fig. 1). The guiding pins (3 Fig. 1) slide in bushes (4 Fig. 1) fitted to the carrier.

The guiding pins are fitted with dust caps which must be fitted when reassembling the caliper.

### Inspection and Cleaning

**WARNING:** BRAKE LINING DUST CAN, IF INHALED, DAMAGE YOUR HEALTH. ALWAYS USE A VACUUM BRUSH TO REMOVE DRY BRAKELINING DUST. NEVER USE AN AIR LINE.

When fitting new brake pads always take necessary precautions and remove the brake dust from around the caliper area. After renewal, pump the brake pedal several times to centralize the new brake pads.

**Note:** If both front and rear calipers have been removed from the vehicle, take care not to mix up left and right hand caliper bodies.

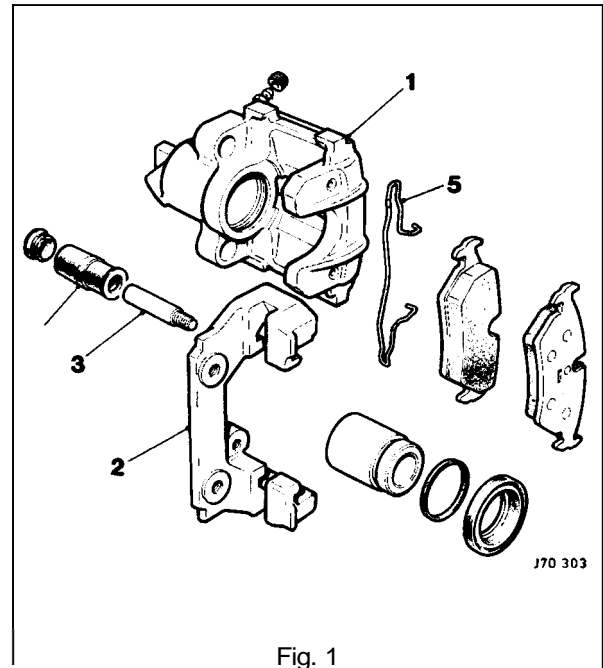

Remove all brake dust from the caliper, carrier and brake rotor. Thoroughly clean the pad abutment areas, avoid damaging the piston and dust cover.

**CAUTION:** When cleaning brake components only use a proprietary fluid. Never use petrol. Use of petrol, paraffin or other mineral based fluids can prove dangerous.

Examine all the components for signs of wear, damage and corrosion. Pay particular attention to the piston and piston bore.

Remove caliper body corrosion with a wire brush or wire wool. No attempt should be made to clean a badly corroded or scored piston bore. The caliper must be renewed.

**CAUTION:** No attempt should be made to clean corroded bolts.

Inspect the caliper guide pins, ensure that they are not corroded or seized and that the caliper moves freely. If they are difficult to remove or corroded in any way, they **must** be replaced together with new dust covers.

**CAUTION:** Ensure that working surfaces and hands are clean. Use only brake fluid of the correct specification to lubricate the new seals when fitting.

When reassembling always renew piston seals. Lubricate the new piston seal and fit carefully to the inner groove of the piston bore.



## 12.1.7. Parking Brake

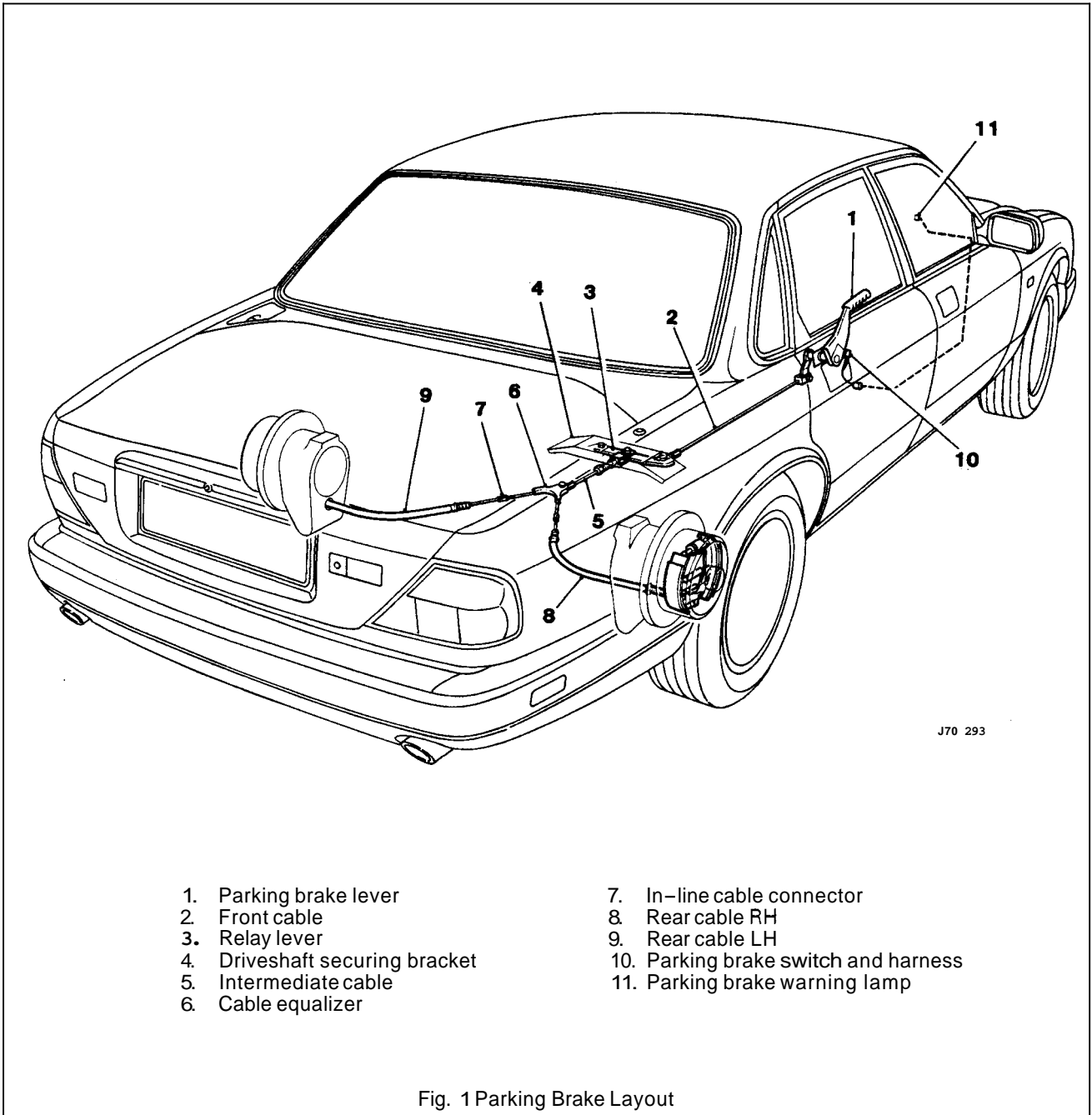

All vehicles are fitted with identical parking brake systems.

When the parking brake lever is operated, the cable system applies equal force to both RH and LH brake shoe expander assemblies. The brake shoes expand and press against the hub assembly, locking the rear wheels.

The handbrake lever, ratchet assembly and warning light switch (item 1) are mounted on the transmission tunnel by means of three flanged screws a blanking plate and gasket. The front cable (item 2) is connected to the relay lever (item 3) which is mounted on the driveshaft securing bracket (item 4). The relay lever operates the intermediate cable (item 5) which incorporates an adjusting screw to allow cable tension to be adjusted. The intermediate cable operates the equalizer which ensures that equal force is applied to RH and LH parking brakes via rear cable RH (item 8) and rear cable LH (item 9). The rear cables are adjustable to allow cable tension to be adjusted.

The park brake switch (item 10) latches when the lever is operated and lights the parking brake warning light (item 11) mounted in the instrument panel.



## Parking Brake Adjustment

Cable slack must be removed by adjustment of the intermediate cable length. The handbrake should be fully on between three and five clicks.

## Parking Brake Shoe Assembly

The parking brakes are of the duo-sew type. The expander assembly (6 Fig. 1) is mounted on the backplate mounting lug. The brake shoes locate on the expander assembly and the adjuster (1 Fig. 1). These are held in position by the upper and lower return springs (4 and 5 Fig. 1) and the hold down springs (2 Fig. 1). The adjuster allows manual adjustment of the brake shoes.

To remove the brake shoe assemblies the handbrake must be released and the adjuster slackened.

The use of a spring removal tool is recommended when removing the brake shoes. Strong pliers may be used, but there is a risk of both personal injury and loss of components, should the pliers slip.

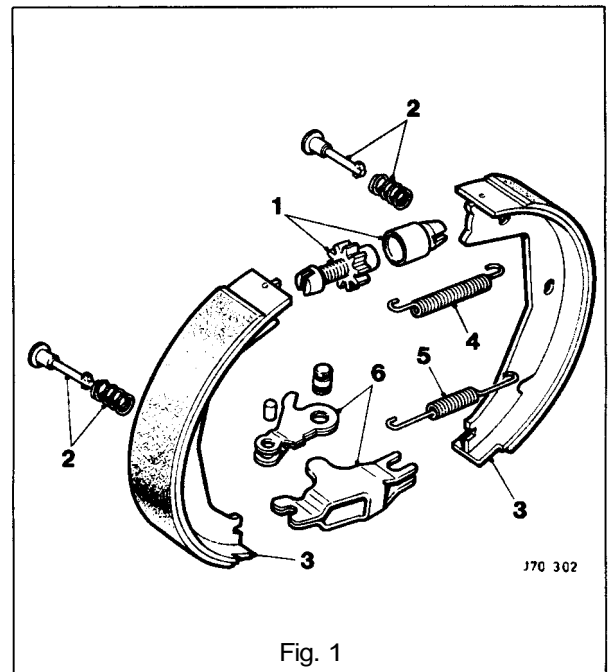

## Inspection and Cleaning

Clean and examine all components for wear or damage, renewing parts as necessary.

When reassembling the expander assembly, liberally grease the components using a proprietary mechanical brake grease. Lightly grease the threads of the adjuster.

**CAUTION:** Do not get grease onto the lining material. Light surface contamination can be removed with emery cloth, but heavy penetration of grease or fluid will render the material unsuitable for further use and the linings must be renewed.

## Re-assembly

When reassembling the brake shoes, lightly grease the shoe tips and back plate contact area. The brake shoes and the expander assembly should be fitted to the backplate with the lower return spring in position. When the brake shoes are located, the adjuster, upper return spring and hold down springs should then be fitted. The brake shoes should be adjusted so that the brake rotor/hub can just be fitted. Final adjustment should allow the brake rotor/hub to rotate without excessive drag. Light running contact is permissible.



**12.1.8. Wheel Speed Sensors**

A toothed wheel, which turns with the road wheel, induces an ac voltage signal in the wheel speed sensor. The frequency and amplitude of the ac voltage varies directly in relation to wheel speed, providing the control module with wheel speed information. Wheel speed sensors are fitted to each road wheel.

**Front**

The front sensors are mounted on the vertical link (1 Fig. 1).

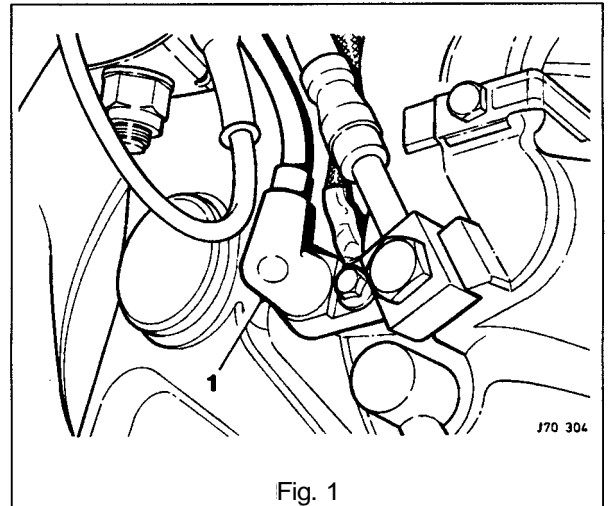

Fig. 1

**Rear**

The rear wheel sensors are mounted on the hub carrier (Fig. 2).

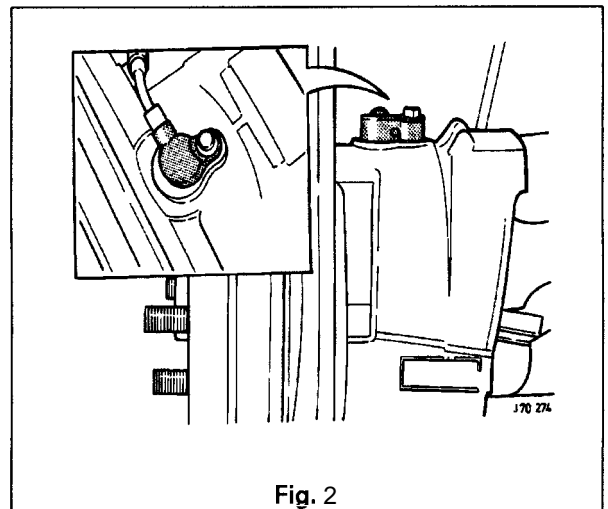
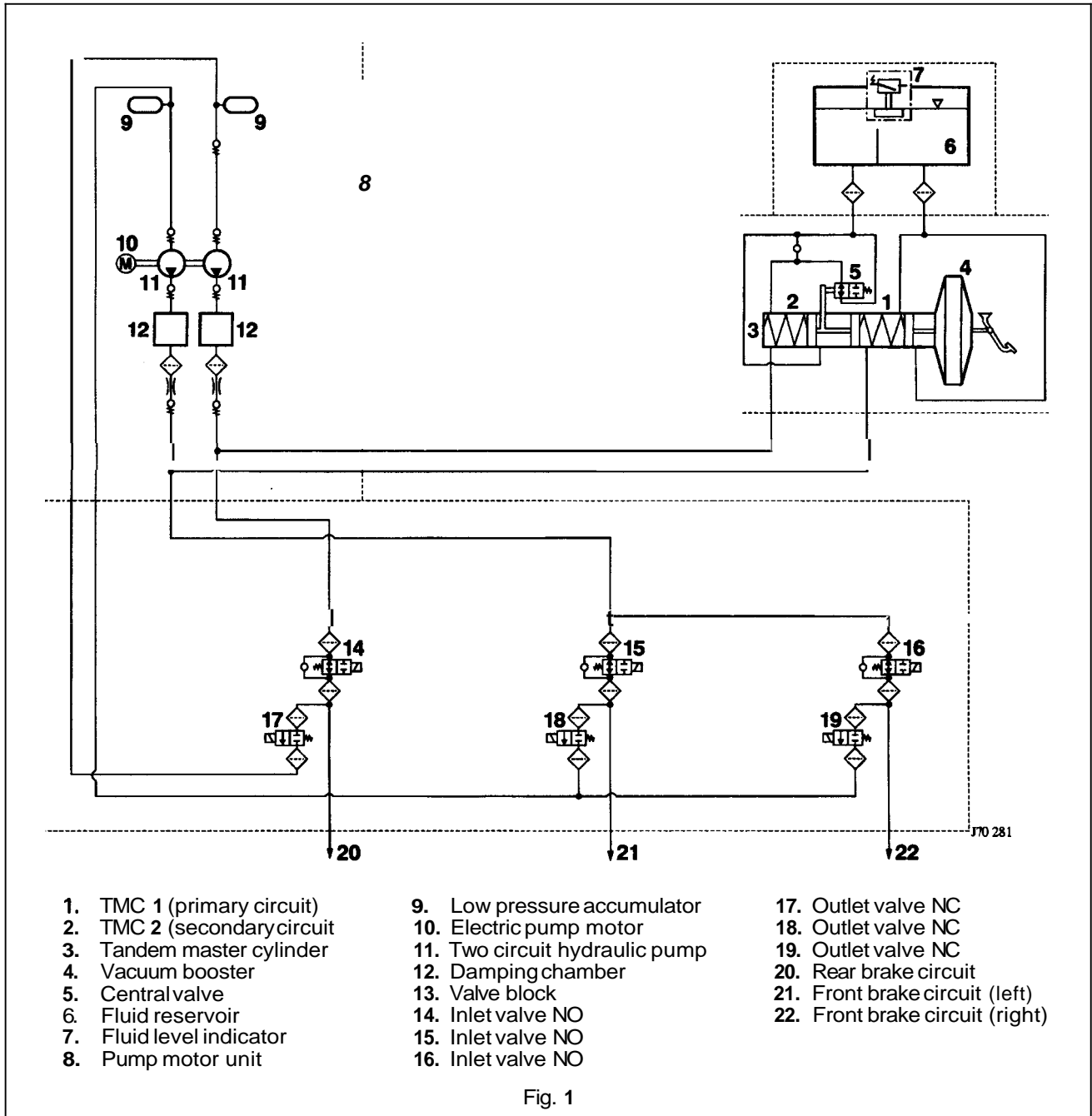

Fig. 2



12.1.9 Hydraulic Operation - ABS CM

The TMC primary circuit (item 1) applies brake pressure to the front brakes. Individual control of the front wheels is provided by solenoid valves, Valves (items 15 and 18) control the front left brake circuit (item 21). Valves (items 16 and 19) control the front right brake circuit (item 22). The TMC secondary circuit (item 2) applies brake pressure to the rear brake circuit (item 20) via valves (items 14 and 17), on a 'select low' principle.



12

Should the ABS be initiated by a locking tendency of any wheel during braking, the pump unit (item 8) is started and the appropriate NO inlet valve (item 14, 15 or 16) closes in response to signals from the control module. This action prevents further increase of brake pressure by blocking the supply of brake fluid from the TMC (item 3). If excessive deceleration continues, the appropriate NC outlet valves (item 17, 18 or 19) opens, releasing brake pressure to the low pressure accumulators (item 9) until the wheel accelerates again.



From the low pressure accumulators, volume is pumped back into the TMC, forcing the brake pedal back. To optimize the friction coefficient between tire and road, brake pressure is increased in small steps by closing the outlet valve and opening the inlet valve and re-charging brake pressure.

During the pressure build up phase, the volume required for replenishment is supplied by the TMC and additionally by the pump from the low pressure accumulators. Since the delivered flow is generally greater than volume flow drained from the brake circuits, the low pressure accumulators serve as intermediate accumulators to compensate for temporary volume flow peaks.

The TMC piston positions, and therefore the brake pedal, vary with the fluid displacement in the brake caliper. As controlled pressure in the brake caliper decreases and increases during ABS, the brake pedal 'cycles', informing the driver that controlled braking is in progress.

Actuation of the brake pedal, causes the central valve (item 5) in the TMC to close. This action prevents damage to the TMC piston seals.

At the end of a brake application, volume is restored to the TMC, at low pressure from the fluid reservoir (item 6).



12.1.10 Hydraulic Operation - ABS / TCCM

ABS / TCCM hydraulic modules incorporate inlet valves (items 16 and 17) and outlet valves (items 20 and 21) for each driven wheel. This enables individual pressure modulation to the rear brakes under wheel spin conditions, i.e. traction control.

Increased wheel spin of a driven wheel under acceleration causes the NO isolation valve (item 14) to be closed and the pump (item 10) to be switched on. This in response to signals from the control module.

Closing of the isolation valve blocks delivery of the pump to the secondary circuit (item 2) of the TMC. The pump now draws fluid from the reservoir via the open hydraulically operated inlet valve (item 13). Increased pressure is now available at the inlet valves (items 16 and 17) for actuating the rear brakes, thus decreasing the tendency of wheel spin.

**Note:** The hydraulic inlet valve (item 13) switches when traction control is initiated to change the suction connection of the pump from the accumulators (item 9) to the fluid reservoir (item 6) via the TMC.

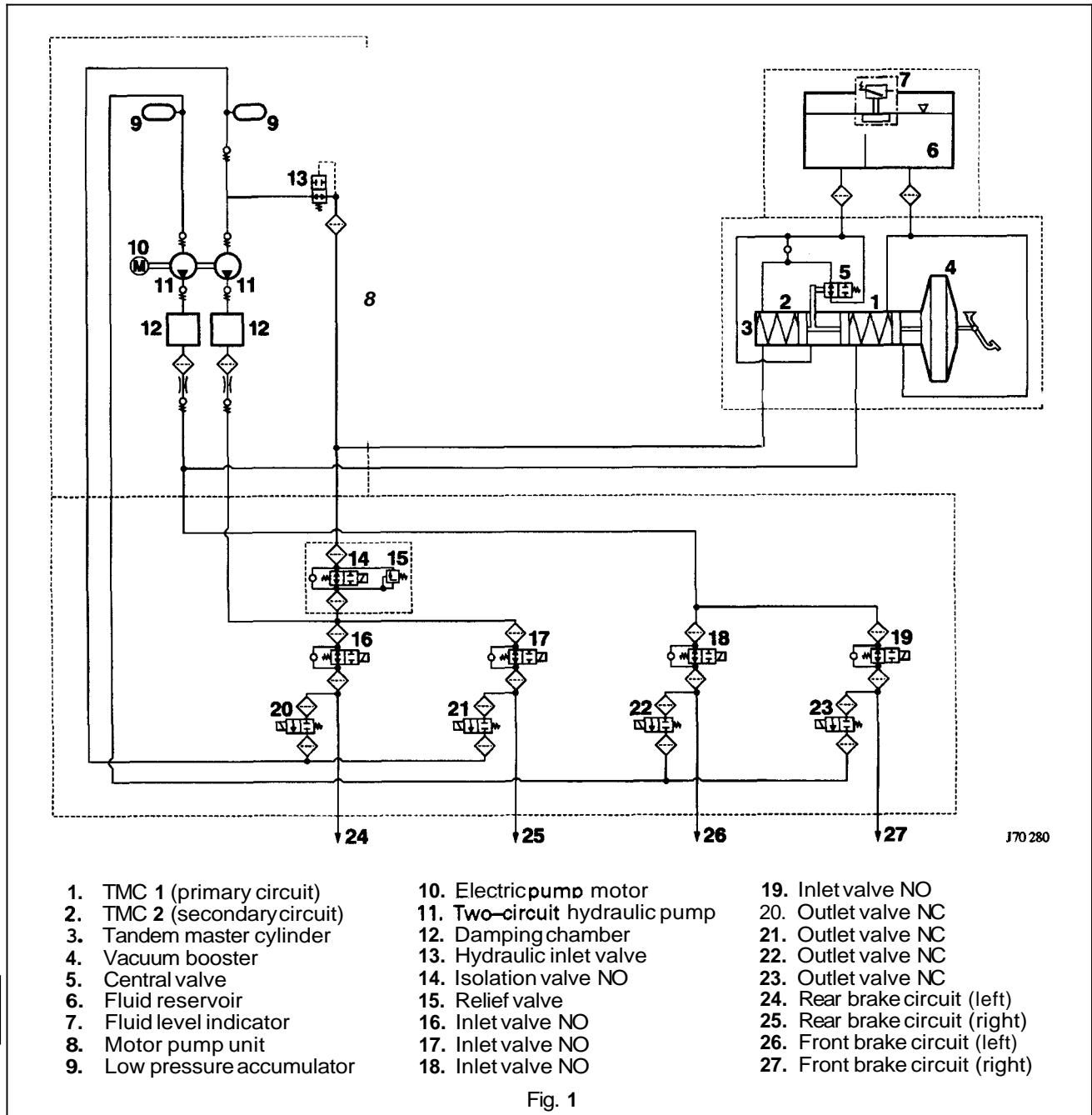

Fig. 1

12



The pressure at the inlet valves corresponds to the opening pressure of the relief valve (item **15**) incorporated in the isolation valve. Excess brake fluid is drained to the suction side of the pump via the relief valve and returns either to the TMC secondary circuit and on to the fluid reservoir, or is directly drawn on by the pump.

As soon as the spinning wheel has been braked down into the normal range of wheel spin, the NO valves (items **16** or **17**) close to prevent any further increase in brake pressure. Depending upon the acceleration of the wheel, the NC valve (item **20** or **21**) may open to decrease the secondary circuit brake pressure. NC valves (item **17** or **18**) may remain closed in order to achieve a brake pressure holding phase. If the pressure in the secondary circuit needs to be increased again, the NC valve closes again (if open) and the NO valve opens, diverting the necessary volume flow. This control action, keeps the wheel in the range of optimum slip until the spinning tendency ceases.

The NO isolation valve (**14**) remains closed throughout the traction control cycle.

An actuation of the brake, sensed by the control module, causes the traction control mode to be terminated and the isolation valve (item **14**) to be opened. The TMC pressure simultaneously closes the hydraulic inlet valve (item **13**) so that the pump can no longer draw fluid from it. The ABS / TC CM now operates in normal ABS mode.

**Note:** When traction control is initiated, speed control is deactivated (if in operation) and requires re-setting after the traction control mode has terminated. Gear shift is inhibited on automatic transmission vehicles; no downshifts are allowed and upshifts occur at **4800** RPM.



## 12.2 FAULT DIAGNOSIS AND TESTING

| Trouble                  | Cause  | Remedy   |
|--------------------------|--|--|
| Long brake pedal         | Brake caliper piston or caliper guide pins sticking<br>Worn / damaged brake pads   | Service or renew caliper or caliper guide pins<br>Renew brake pads   |
| Vibration during braking | Worn / damaged brake pads<br>Loose caliper mounting bolts<br>Insufficient grease on sliding parts<br>Foreign material or scratches on brake rotor contact surface<br>Damaged brake rotor contact surface   | Renew brake pads<br>Tighten caliper mounting bolts<br>Apply grease where necessary<br>Clean brake rotor contact surface<br>Renew brake rotor   |
| Poor braking performance | Leak in hydraulic system<br>Air in system<br>Worn / damaged brake pads<br>Foreign material on brake pads<br>Brake caliper piston malfunction<br>Tandem master cylinder malfunction<br>Vacuum booster fault<br>Disconnected or damaged vacuum hose<br>Low brake fluid level | Repair leak. Check all pipework connections. Refill and bleed the system<br>Check the system for leaks and bleed brakes<br>Renew brake pads<br>Examine brake pads and clean or renew as necessary<br>Renew faulty brake caliper piston<br>Service or renew tandem master cylinder<br>Renew vacuum booster<br>Renew vacuum hose<br>Check for leaks, refill and bleed the system |
| Brakes pull to one side  | Worn / damaged brake pads<br>Foreign material on brake pad<br>Failing valves in ABS valve block<br>Abnormal wear or distortion on front brake rotor<br>Incorrect wheel alignment<br>Incorrect tire pressure  | Renew brake pads<br>Examine brake pads and clean or renew as necessary<br>Renew valve block<br>Examine front brake rotor and service or renew as necessary<br>Carry out wheel alignment. Refer to Section 11, iv Service Data<br>Inflate tire to correct pressure  |
| Brakes do not release    | No brake pedal free play<br>Vacuum booster binding<br>Tandem master cylinder return port faulty<br>Faulty valve in ABS valve block   | Adjust brake pedal free play<br>Renew vacuum booster<br>Clean return port on tandem master cylinder<br>Renew valve block   |
| Excessive pedal travel   | Leak in hydraulic system<br>Air in system  | Repair leak. Check all pipework connections. Refill and bleed the system<br>Check the system for leaks and bleed brakes  |



## 12.2 (continued)

| Trouble                         | Cause  | Remedy  |
|---------------------------------|--|---|
| Excessive pedal travel (Cont'd) | Worn tandem master cylinder piston seals or scored cylinder bore<br>'knock back'. Excessive brake rotor run-out or loose wheel bearings  | Renew tandem master cylinder<br>Check brake rotor run-out and renew as necessary. Adjust wheel bearing  |
| Brakes grab                     | Brake pads contaminated by grease or brake fluid<br>Brake pads distorted, cracked or loose<br>Loose caliper mounting bolts or guide pins   | Renew brake pads. Check pipework for leaks<br>Renew brake pads<br>Check caliper and repair / renew as necessary   |
| Brakes drag                     | Seized or incorrectly adjusted parking brake or cable<br>Broken or weak parking brake return springs<br>Caliper pistons seized<br>Brake pedal binding at pivot points<br>Vacuum booster binding<br>Tandem master cylinder faulty | Examine parking brake and repair / renew as necessary<br>Renew parking brake return springs<br>Examine calipers and repair / renew as necessary<br>Examine brake pedal bushings and repair / renew as necessary<br>Renew vacuum booster<br>Examine tandem master cylinder and repair / renew as necessary |
| Hard brake pedal when pressed   | Lack of vacuum at the vacuum booster<br>Tandem master cylinder pushrod binding<br>Frozen tandem master cylinder piston<br>Brake caliper piston or caliper guide pins seized  | Check vacuum hose. Repair or renew as necessary<br>Renew tandem master cylinder<br>Renew tandem master cylinder<br>Examine caliper and renew / repair as necessary  |
| Excessive brake noise           | Worn brake pads<br>Bent or cracked parking brake shoes<br>Foreign objects in brake pads or parking brake shoes<br>Broken / loose parking brake hold down springs or return springs<br>Loose caliper mounting bolts               | Renew brake pads<br>Renew parking brake shoes<br>Examine brake pads and parking brake shoes. Clean or renew as necessary<br>Examine parking brake assembly. Repair or renew as necessary<br>Re-torque caliper mounting bolts  |





## 12.3 BRAKE FLUID LEVEL CHECK

**WARNING:** AVOID SKIN / EYE CONTACT OR INGESTION OF BRAKE FLUID. IF SKIN OR EYES ARE ACCIDENTALLY SPLASHED WITH BRAKE FLUID, RINSE THE AFFECTED AREA IMMEDIATELY WITH PLENTY OF WATER AND SEEK MEDICAL ATTENTION IMMEDIATELY.

### Checking the fluid level

**CAUTION:** Fluid must not be allowed to contact the vehicle paintwork. Remove any spilt fluid from the paintwork by rinsing away with running water. Methylated spirit (denatured alcohol) must not be used to clean the contaminated area.

Correct brake fluid level is essential for the efficient operation of the brake system. Check that the fluid level is between the MAX and MIN marks on the fluid reservoir (Fig. 1). Top up if necessary with recommended brake fluid.

**Note:** The efficiency of the brakes may be impaired if fluid is used which does not meet specifications. Use ONLY brake and clutch fluid that conforms to a minimum DOT 4 specification. Also do not use brake fluid that has been exposed to atmosphere for any length of time. Moisture absorbed from the atmosphere impairs the efficiency of the brake fluid.

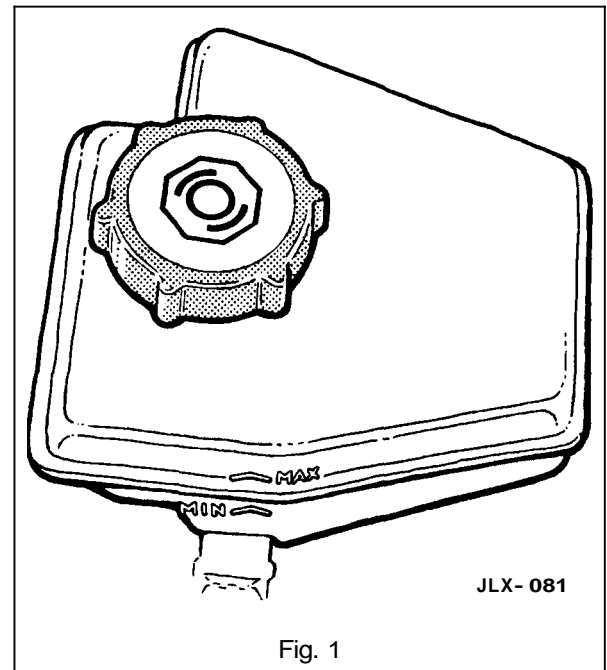

Fig. 1



## 12.4 BRAKE SYSTEM BLEEDING

**WARNING:** GREAT CARE MUST BE EXERCISED WHEN SERVICING OR REPAIRING THE SYSTEM. AVOID SKIN/ EYE CONTACT OR INGESTION OF BRAKE FLUID. IF SKIN OR EYES ARE ACCIDENTALLY SPLASHED WITH BRAKE FLUID, RINSE THE AFFECTED AREA IMMEDIATELY WITH PLENTY OF WATER AND SEEK MEDICAL ATTENTION. IF BRAKE FLUID IS INGESTED, SEEK MEDICAL ATTENTION IMMEDIATELY.

**CAUTION:** Fluid must not be allowed to contact the vehicle paintwork. Remove any spilt fluid from the paintwork by rinsing away with running water. Methylated spirit (denatured alcohol) must not be used to clean the contaminated area.

**CAUTION:** Never use methylated spirit (denatured alcohol) for component cleaning purposes. Use only a proprietary brake cleaning fluid.

**WARNING:** THROUGHOUT THE FOLLOWING MAINTENANCE / SERVICE OPERATIONS, ABSOLUTE CLEANLINESS MUST BE OBSERVED TO PREVENT FOREIGN MATTER CONTAMINATING THE BRAKE SYSTEM.

### 12.4.1 System Bleeding – General Instructions

Use a brake bleeder bottle with a clear bleeder tube. Also recommended is a filler unit with a fill pressure of 1.0 bar. If a filler unit is not used, ensure that there is sufficient brake fluid in the reservoir throughout the bleeding procedure.

**Note:** Always bleed the caliper furthest away from the actuation unit first. On right hand drive vehicles, bleed in the following order: front left (FL), front right (FR), rear left (RL) and rear right (RR). On left hand drive vehicles bleed in the following order: FR, FL, RR and RL.

### 12.4.2 System Bleeding After Brake Fluid Renewal

- Ensure that the vehicle is standing level. Switch the ignition off.
- Check that the fluid level in the reservoir is between the min and max marks.
- Connect the bleeder bottle tube to the relevant front caliper (see 'note' above) bleeder screw (1 Fig. 1) and open the screw.
- Bleed until new, clear, bubble free fluid is observed in the tube and then close the bleeder screw.
- Repeat this procedure at each remaining caliper.
- With the motor running check brake pedal travel. If excessive, check for leaks and repeat the bleed procedure.
- Fill the reservoir to the max level.

### 12.4.3 System Bleeding After Tandem Master Cylinder Renewal

- Ensure that the vehicle is standing level. Switch the ignition off.
- Check that the fluid level in the reservoir is between the min and max marks.
- Connect the bleeder bottle tube to the relevant front caliper (see 'note' above) bleeder screw (1 Fig. 1) and open the screw.

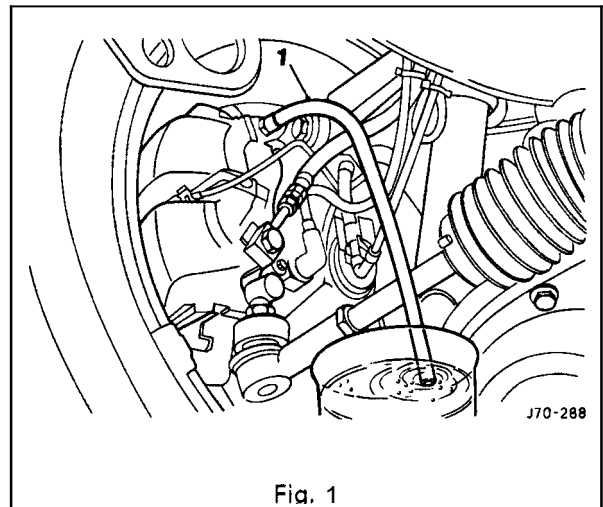

Fig. 1



- Actuate the brake pedal to the floor, hold for approximately two seconds and then release the pedal. Wait another two seconds and actuate the brake pedal again for a further two seconds. Repeat this action 20 to 30 times until clear, bubble free brake fluid streams out.
- With the brake pedal actuated, close the bleeder screw. Build up fluid pressure by pumping the pedal and then open the bleeder screw. Repeat this action three to five times.

**Note:** If a filler unit is not used, observe the fluid level in the reservoir and top up if necessary.

- Repeat this procedure for the remaining three calipers. (1 Fig. 1) shows the bleeder screw of the rear left caliper.
- With the motor running check brake pedal travel. If excessive, check for leaks and repeat the bleed procedure.
- Fill the reservoir to the max level.

#### 12.4.4 System Bleeding After Hydraulic Control Module Renewal

Hydraulic control modules are supplied pre-filled to enable the brake system to be bled in the conventional way.

- Ensure that the vehicle is standing level. Switch the ignition off.
- Check that the fluid level in the reservoir is between the min and max marks.
- Connect the bleeder bottle tube to the relevant front caliper (see 'note' on previous page) bleeder screw (1 Fig. 1) and open the screw.
- Actuate the brake pedal full stroke, wait a moment and then release. Wait two to three seconds and then actuate the brake pedal full stroke again. This allows the TMC to be completely re-filled with fluid.
- Repeat 20 to 30 times until the fluid in the bleeder tube is clear and bubble free.
- With the brake pedal actuated, close the bleeder screw. Build up fluid pressure by pumping the pedal and then open the bleeder screw. Repeat this action three times.

**Note:** If a filler unit is not used, observe the fluid level in the reservoir and top up if necessary.

- Repeat this procedure for the remaining three calipers.
- With the motor running check brake pedal travel. If pedal travel is excessive, check the system for leaks and repeat the bleed procedure.
- Fill the reservoir to the max level.

#### 12.4.5 Bleeding After Renewal of Caliper

Follow the procedure above but only at the affected caliper.

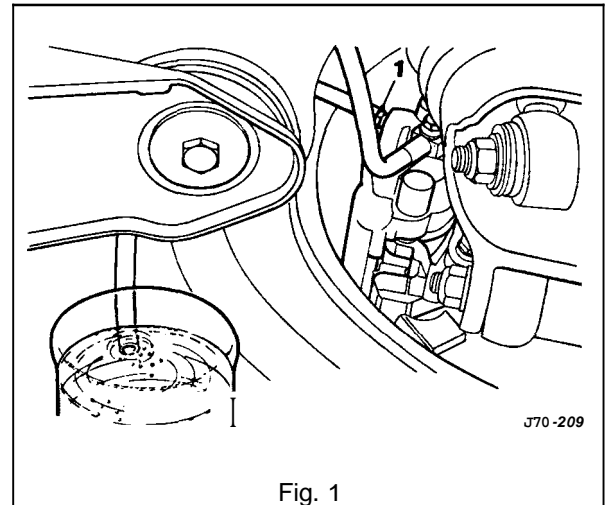



## 12.5 GENERAL FITTING INSTRUCTIONS

### 12.5.1 Brake Fluid

**WARNING:** BRAKE FLUID IS CORROSIVE. EXTREME CARE MUST BE TAKEN WHEN HANDLING. AVOID SKIN OR EYE CONTACT. AVOID INGESTION. IF SKIN OR EYES ARE ACCIDENTALLY SPLASHED WITH BRAKE FLUID, RINSE THE AFFECTED AREA IMMEDIATELY WITH PLENTY OF WATER AND SEEK MEDICAL ATTENTION. IF BRAKE FLUID IS INGESTED, SEEK MEDICAL ATTENTION IMMEDIATELY.

**CAUTION:** Fluid must not be allowed to contact the vehicle paintwork. Remove any spilt fluid from the paintwork by rinsing away with running water. Methylated spirit (denatured alcohol) must not be used to clean the contaminated area.

### Cleaning Solvents

**CAUTION:** Never use methylated spirit (denatured alcohol) for cleaning purposes. Use only a proprietary brake cleaning fluid.

**WARNING:** THROUGHOUT THE FOLLOWING MAINTENANCE / SERVICE OPERATIONS, ABSOLUTE CLEANLINESS MUST BE OBSERVED TO PREVENT GRIT OR OTHER FOREIGN MATTER CONTAMINATING THE BRAKE SYSTEM. IF THE SYSTEM IS TO BE FLUSHED, USE CLEAN BRAKE FLUID TO MINIMUM DOT 4 SPECIFICATION. TO CLEAN BRAKE SYSTEM COMPONENTS, WASH IN A PROPRIETARY BRAKE CLEANING FLUID. REMOVE ALL TRACES OF CLEANING FLUID BEFORE REASSEMBLY. ALL BRAKE SYSTEM RUBBER COMPONENTS MUST BE DIPPED IN CLEAN BRAKE FLUID AND ASSEMBLED USING THE FINGERS ONLY.

### 12.5.2 Hoses

- Fully release the unions (1 Fig. 1) securing each end of the hose to the fluid pipes. Withdraw the pipe unions (1 Fig. 1) from the hose ends.
- Plug the ends of the pipes (2 Fig. 1) to prevent the loss of fluid and the ingress of dirt.
- Remove the mounting bracket locknut (3 Fig. 1) and remove the hose (4 Fig. 1).
- Thoroughly clean the hose and examine for any signs of wear or damage. Renew the hose if there is any doubt about its condition. Thoroughly clean the bore of the hose using compressed air.
- Remove all blanking plugs and fit the new hose to the caliper/connector. Secure the hose to the mounting bracket.
- Before fully tightening the locknut, ensure that the hose is neither kinked nor twisted.
- Bleed the brakes.

### 12.5.3 Pipes

- Fully release the pipe unions (1 Fig. 1).
- Withdraw the pipe (5 Fig. 1) from the vehicle. Plug the pipes (2 Fig. 1) to prevent the loss of fluid or the ingress of dirt. Thoroughly clean and examine the pipe for signs of damage or deterioration. Renew the pipe if there is any doubt about its condition.
- Thoroughly clean the bore of the pipe using compressed air.
- Remove all blanking plugs and fit the new pipe to the vehicle. Secure the pipe to the body.
- Bleed the brakes.

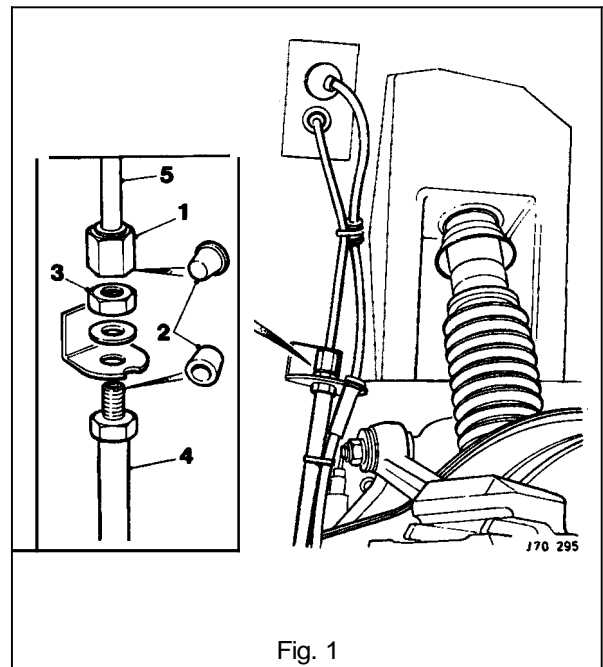

Fig. 1



## 12.6 REAR WHEEL SPEED SENSOR – RENEW

### SRO 70.60.04

- Drive the vehicle onto a ramp or raise the back and support on two stands.
- Cut and remove the ratchet strap securing the speed sensor harness to the brake hose.
- Undo and remove the speed sensor to hub carrier securing bolt (Fig. 1).
- Remove the speed sensor from the hub carrier and allow it to hang free, forward of the 'A' frame.
- Open both rear doors and displace the rear seat cushion from the seat pan brackets. Reposition the rear seat cushion forwards.
- Push the seat belts / buckles through the seat cushion slots and remove the rear seat cushion from the vehicle.
- Displace the RH side of the seat pan sound proofing (1 Fig. 2) to gain access to the speed sensor harness (2 Fig. 2).
- Displace the speed sensor harness grommet (3 Fig. 2) from the seat pan aperture.
- Feed the speed sensor harness through the seat pan aperture and disconnect the multi-plug (4 Fig. 2).
- Position the new speed sensor harness and connect the multi-plug.
- Feed the speed sensor harness through the seat pan aperture to hang free below the vehicle.
- Refit and fully seat the speed sensor harness grommet to the seat pan aperture.
- Reposition the seat pan sound proofing to its original position.
- Position the rear seat cushion and feed the seat belt / buckles through the slots.
- Locate the rear seat cushion into the seat pan brackets (5 Fig. 2).
- Stow the seat belts / buckles.
- Position the speed sensor harness rearwards over the 'A' frame and locate into the hub carrier.
- Fit and tighten the speed sensor to hub carrier securing bolt.
- Secure the speed sensor harness to the brake hose using a ratchet strap. Trim the ratchet strap.

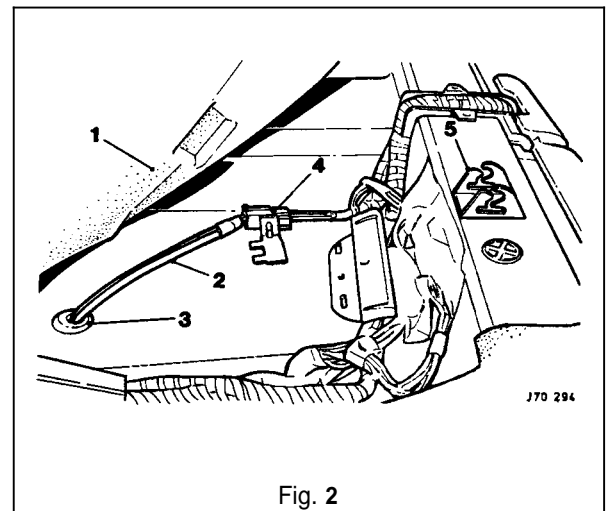
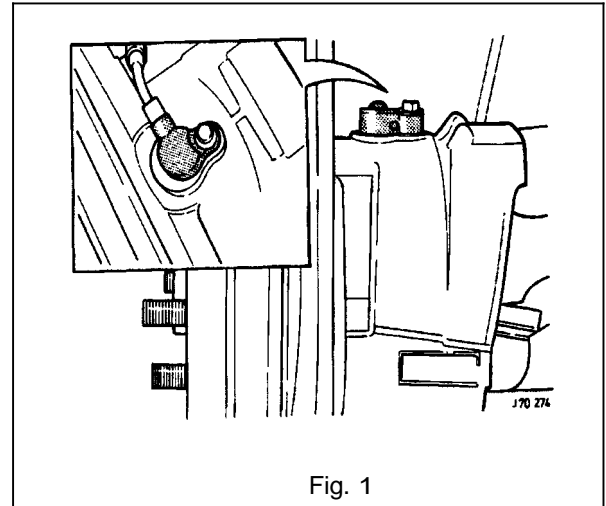



## 12.7 HYDRAULIC CONTROL MODULE - RENEW

SRO 70.60.18  
70.60.19

Refer to Section 12.4, Brake System Bleeding before carrying out this procedure. Pay particular attention to the warnings and cautions relating to brake fluid, cleanliness and cleaning materials.

**Note:** The illustration shows the hydraulic control module of a 6cyl. vehicle with traction control. Hydraulic control modules on non-traction control vehicles have only three outlet ports. Apart from this, the removal procedure is the same for all vehicles.

- Raise the vehicle.
- Displace the bleeder screw dust cap of the front LH caliper. The dust cap will remain captive on the bleed screw.
- Connect a bleeder tube and bottle to the bleeder screw (1 Fig. 1) and open the bleeder screw.
- Fit a brake pedal hold-down tool (JDS-9013) between the brake pedal and the steering wheel. Adjust the tool to operate the brake pedal 60mm down. This operation is necessary to prevent fluid loss from the reservoir through disconnected brake pipes.
- Re-tighten the front LH caliper bleeder screw. Disconnect the bleeder tube from the bleeder screw and remove the tube and bottle. Refit the bleeder screw dust cap.
- Undo the securing bolt of the multi-plug connector (1 Fig. 2). The bolt will remain captive. Disconnect the multi-plug connector and reposition safely.
- Place absorbent material underneath the hydraulic control module to absorb any spillages.
- Undo the tandem master cylinder (TMC) brake pipe gland nuts (2 Fig.2) and disconnect the brake pipes.
- Fit plugs immediately to the brake pipes and the hydraulic control module to prevent fluid loss.
- Undo the rear brake pipe gland nuts (3 Fig. 2) at the pressure conscious reducing valves (PCRVs) (4 Fig. 2). Remove the rear brake pipes.

**Note:** Take necessary steps to prevent rotation of the PCRVs when removing the rear brake pipes.

- Fit plugs immediately to the brake pipes and the PCRVs to prevent fluid loss.
- Undo and remove the PCRVs. Fit plugs immediately to the PCRVs and the hydraulic control module.
- Place PCRVs aside to be fitted later to the new hydraulic control module.
- Undo the front brake pipe gland nuts (5 Fig. 2) and remove the front brake pipes.
- Fit plugs immediately to the brake pipes and the hydraulic control module to prevent fluid loss.
- Undo and remove the three securing nuts (6 Fig. 2) and remove the hydraulic control module.

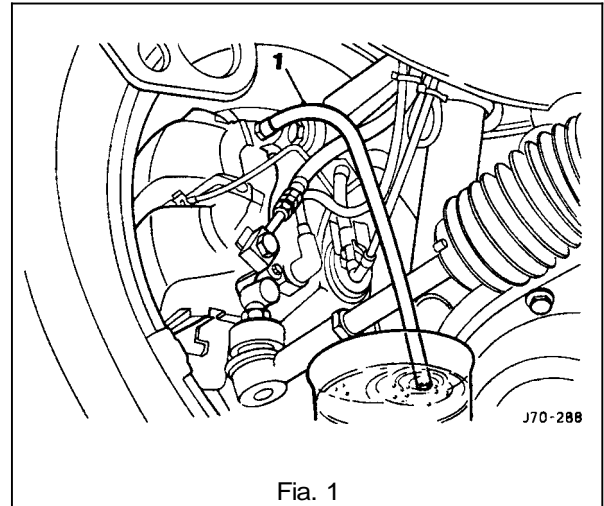

Fia. 1

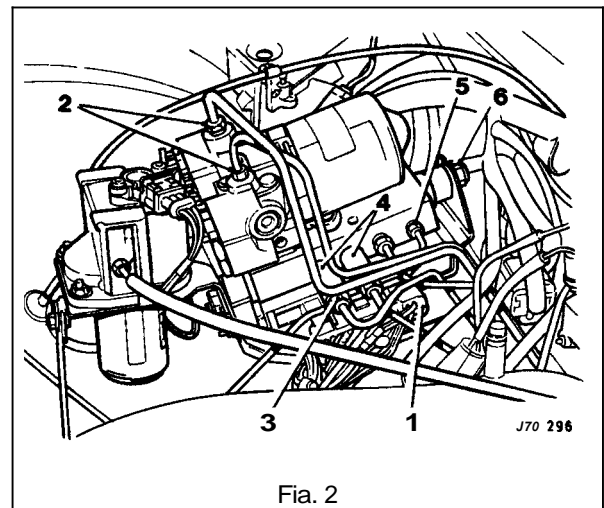

Fia. 2



- Remove the absorbent material and clean the mounting bracket and surrounding area.
- Fit and align a new hydraulic control module to the mounting bracket. Ensure that the mounting cup tangs fully engage the bracket slots.
- Fit and tighten the securing nuts (6 Fig. 1).
  - Place absorbent material underneath the hydraulic control module to absorb any spillages.
- Connect the front hydraulic brake pipes (5 Fig. 1) to the hydraulic control module, removing plugs immediately prior to connection. Tighten the gland nuts.
- Fit the PCRVs (4 Fig. 1) to the hydraulic control module, removing plugs immediately prior to connection. Tighten the PCRVs.
- Connect the rear hydraulic brake pipes (3 Fig. 1) to the PCRVs, removing the plugs immediately prior to connection. Tighten the gland nuts.

**Note:** Take necessary steps to prevent rotation of the PCRVs when fitting the rear brake pipes.

- Connect the TMC hydraulic brake pipes (2 Fig. 1) to the hydraulic control module, removing the plugs immediately prior to connection. Tighten the gland nuts.
- Remove the absorbent material and clean the surrounding area.
- Reposition and connect the multi-plug connector. Tighten the securing bolt (1 Fig. 1).
- Ensure that all fixings are torque tightened to specified tolerances.
- Release the brake pedal hold-down tool and remove.
- Bleed the brake system (refer to sub-section 12.4.4).
- Examine the hydraulic control module for leaks.

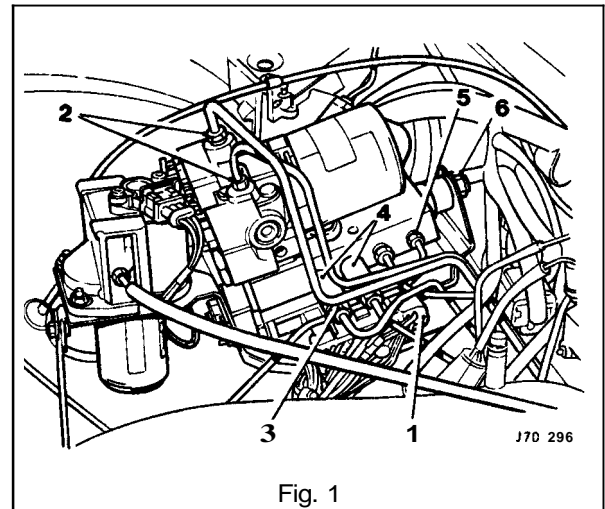



## 12.8 PRESSURE CONSCIOUS REDUCING VALVES - RENEW

### SRO 70.60.21

Refer to Section 12.4, Brake System Bleeding before carrying out this procedure. Pay particular attention to the warnings and cautions relating to brake fluid, cleanliness and cleaning materials.

**Note:** The illustration shows the hydraulic control module of a 6 cyl. vehicle with traction control. Hydraulic control modules on non-traction control vehicles have only three outlet ports. Apart from this, the removal procedure is the same for all vehicles.

- Raise the vehicle.
- Displace the bleeder screw dust cap of the front LH caliper. The dust cap will remain captive on the bleed screw.
- Connect a bleeder tube and bottle to the bleeder screw (1 Fig. 1) and open the bleeder screw.
- Fit a brake pedal hold-down tool (JDS-9013) between the brake pedal and the steering wheel. Adjust the tool to operate the brake pedal 60mm down. This operation is necessary to prevent fluid loss from the reservoir through disconnected brake pipes.
- Re-tighten the front LH caliper bleeder screw. Disconnect the bleeder tube from the bleeder screw and remove the tube and bottle. Refit the bleeder screw dust cap.
- Place absorbent material underneath the hydraulic control module to absorb any spillages.
- Undo the rear brake pipe gland nuts (1 Fig. 2) at the pressure conscious reducing valves (PCRVs) (2 Fig. 2). Remove the rear brake pipes.

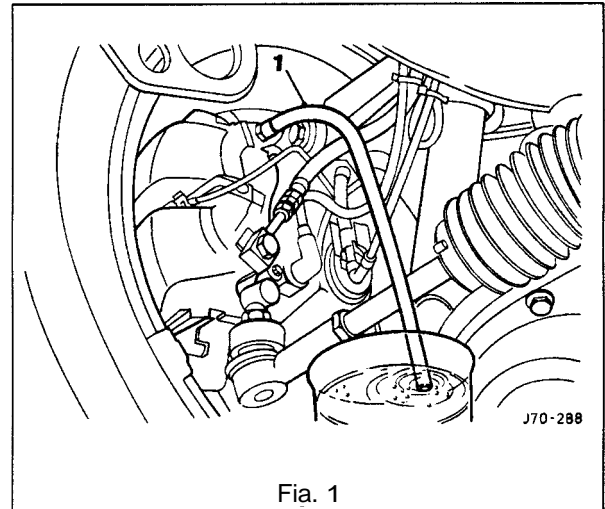

Fia. 1

**Note:** Take necessary steps to prevent rotation of the PCRVs when removing the rear brake pipes.

- Fit plugs immediately to the brake pipes and the PCRVs to prevent fluid loss.
- Undo and remove the PCRVs. Fit plugs immediately to the PCRVs and the hydraulic control module.
- Clean the surrounding area.
- Fit new PCRVs to the hydraulic control module, removing plugs immediately prior to connection. Tighten the PCRVs.
- Connect the rear hydraulic brake pipes to the PCRVs, removing the plugs immediately prior to connection. Tighten the gland nuts.

**Note:** Take necessary steps to prevent rotation of the PCRVs when fitting the rear brake pipes.

- Remove the absorbent material and clean the surrounding area.
- Ensure that all fixings are torque tightened to specified tolerances.
- Release the brake pedal hold-down tool and remove.
- Bleed the brake system (refer to sub-section 12.4.4).
- Examine the hydraulic control module for leaks.

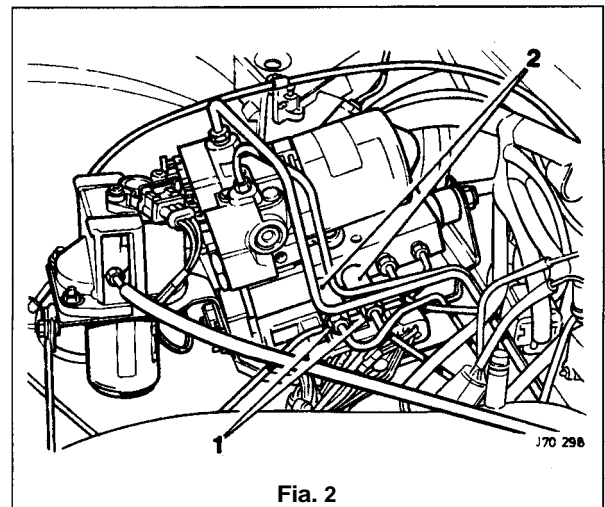

Fia. 2





## 12.9 ABS / TCCM - RENEW

SRO 70.60.02  
70.60.20

Refer to Section 12.4, Brake System Bleeding before carrying out this procedure. Pay particular attention to the warnings and cautions relating to brake fluid, cleanliness and cleaning materials.

- Remove the hydraulic control module. Refer to sub-section 12.7, SROs 70.60.18 & 19.
- Disconnect the pump electric motor to ABS / TC CM multi-plug (1 Fig 1).
- Undo and remove two securing screws and remove the ABS / TC CM.
- Clean the mating faces of the hydraulic control module and the new ABS / TC CM. Fit and tighten two securing screws.
- Re-connect the pump electric motor to ABS / TCCM multi-plug.
- Refit the hydraulic control module. Refer to sub-section 12.7, SROs 70.60.18 & 19.

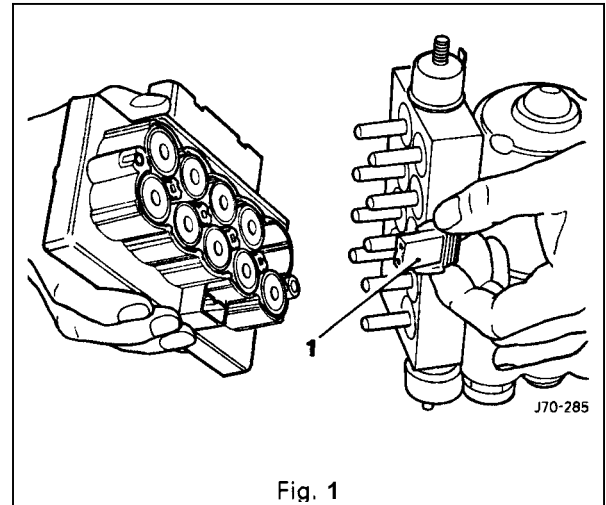



# Body Components & Trim

## SECTION CONTENTS

| Sub-Section | Title   | SRO         | Page   |
|-------------|---|-------------|--------|
| I to V      | Preliminary Pages   |             | i to v |
| 13.1        | General Description   |             | 1      |
| 13.2        | Door and Fuel Filler Flap   |             | 2      |
| 13.2.1      | Doors. Description  |             | 2      |
| 13.2.2      | Front Door Trim Pad Veneer Panel. Renew                               | 76.47.11    | 2      |
| 13.2.2.     | Rear Door Trim Pad Veneer Panel. Renew                                | 76.47.12    | 2      |
| 13.2.3      | Rear Door Upper Trim Pad. Remove For Access and Refit                 | 76.34.05/90 | 3      |
| 13.2.4      | Rear Door Upper Trim Pad, Renew                                       | 76.34.05    | 3      |
| 13.2.5      | Rear Door Window Lift Switch Veneer Panel. Renew                      | 76.47.34    | 3      |
| 13.2.6      | Rear Door Lower Trim Pad, Remove for Access and Refit                 | 76.34.06/90 | 4      |
| 13.2.7      | Rear Door Lower Trim Pad, Renew                                       | 76.34.06    | 4      |
| 13.2.8      | Rear Door Armrest. Renew  | 76.34.23    | 5      |
| 13.2.9      | Rear Door Pocket, Renew   | 76.34.28    | 5      |
| 13.2.10     | Front Door Upper Trim Pad, Renew                                      |             | 6      |
| 13.2.11     | Front Door Lower Trim Pad, Renew                                      |             | 6      |
| 13.2.12     | Door Lock Barrel, Renew   |             | 6      |
| 13.2.13     | Front or Rear Door Lock Striker, Renew                                |             | 6      |
| 13.2.14     | Front or Rear Door Outer Handle Operating Rod, Renew                  |             | 6      |
| 13.2.15     | Front Armrest, Renew  |             | 7      |
| 13.2.16     | Front or Rear Armrest Support. Renew                                  |             | 7      |
| 13.2.17     | Front Door Pocket. Renew  |             | 7      |
| 13.2.18     | Fuel Filler Flap, Description   |             | 8      |
| 13.2.19     | Filler Flap and Hinge, Renew  |             | 8      |
| 13.2.20     | Filler Cap Retention Magnet. Renew                                    |             | 8      |
| 13.2.21     | Filler Flap Latching Assembly, Renew                                  |             | 8      |
| 13.3        | Passenger Compartment.  |             | 9      |
| 13.3.1      | Console Assembly, Remove for Access and Refit                         | 76.25.01/90 | 9      |
| 13.3.2      | Console Assembly, Renew (Daimler/ VDP)                                | 76.25.01/50 | 10     |
| 13.3.3      | Console Assembly, Remove for Access and Refit (Daimler/ VDP)          | 76.25.01/91 | 12     |
| 13.3.4      | Console Assembly, Renew   | 76.25.01    | 13     |
| 13.3.5      | Console Rear Extension Finisher, Renew                                | 76.25.04    | 14     |
| 13.3.6      | Console Rear Extension. Renew   | 76.25.05    | 14     |
| 13.3.7      | Selector Trim Finisher, Renew (3.2 Liter)                             | 76.25.07    | 14     |
| 13.3.8      | Selector Trim Finisher, Renew (4.0 Liter, 4.0 Liter SC and 6.0 Liter) | 76.25.07    | 15     |
| 13.3.9      | Mode Switch Finisher, Renew   | 76.25.09    | 15     |
| 13.3.10     | Radio Console, Renew  | 76.25.15    | 16     |
| 13.3.11     | Console Glove Box, Renew  | 76.25.16    | 17     |
| 13.3.12     | Console Glove Box Lid, Renew  | 76.25.18    | 18     |
| 13.3.13     | Console Glove Box Lid Hinge, Renew                                    | 76.25.20    | 19     |
| 13.3.14     | Cupholder Trim Panel, Renew   | 76.25.21    | 19     |
| 13.3.15     | Cupholder, Renew  | 76.25.22    | 20     |
| 13.3.16     | Cupholder Latch, Renew  | 76.25.23    | 20     |
| 13.3.17     | Fascia Board, Renew   | 76.46.01    | 21     |
| 13.3.18     | Fascia Board. Remove for Access and Refit                             | 76.46.01/90 | 24     |



## SECTION CONTENTS

| <b>Sub-Section</b> | <b>Title</b>  | <b>SRO</b>   | <b>Page</b> |
|--------------------|---|--------------|-------------|
| 13.3.19            | Underscuttle Pad. Drivers Side. Remove for Access and Refit   | 76.46.1 1/90 | 26          |
| 13.3.20            | Underscuttle Pad. Passenger Side. Remove for Access and Refit | 76.46.15/90  | 26          |
| 13.3.21            | Fascia Closing Panel – Passenger Side. Renew                  | 76.46.27     | 27          |
| 13.3.22            | Fascia Closing Panel – Drivers Side. Renew                    | 76.46.28     | 27          |
| 13.3.23            | Fascia Center Veneer Panel. Renew                             | 76.47.06     | 28          |
| 13.3.24            | Console Finisher Veneer Panel. Renew                          | 76.47.26     | 29          |
| 13.3.25            | Console Ashtray Lid Veneer Panel. Renew                       | 76.47.27     | 30          |
| 13.3.26            | Console Ashtray Surround Veneer Panel. Renew                  | 76.47.28     | 30          |
| 13.3.27            | Console Rear Extension Veneer Panel. Renew                    | 76.47.30     | 30          |
| 13.3.28            | Console Ashtray, Renew  | 76.67.18     | 31          |
| 13.3.29            | Steering Column Upper cowl. Renew                             | 76.46.02     | 32          |
| 13.3.30            | Steering Column Lower cowl. Renew                             | 76.46.03     | 32          |
| 13.3.31            | Steering Column Switchgear Mounting Bracket. Renew            | 76.46.33     | 33          |
| 13.3.32            | 'A' Post Lower Trim Pad. Renew                                | 76.13.30     | 35          |
| 13.3.33            | Rear Quarter Upper Trim Pad. Renew                            |              | 35          |
| 13.3.34            | 'B' Post Upper Trim Pad. Renew                                |              | 35          |
| 13.3.35            | 'B' Post Lower Trim Pad. Renew                                |              | 35          |
| 13.3.36            | Handbrake Lever Trim. Renew                                   |              | 35          |
| 13.3.37            | Combined Grab Handle and Coat Hanger Hook. Renew              |              | 35          |
| 13.3.38            | Sun Visor Assembly RH or LH. Renew                            |              | 36          |
| 13.3.39            | Roof Lining (Headlining). Description                         |              | 37          |
| 13.3.40            | Roof Lining. Renew  |              | 37          |
| 13.4               | Trunk   |              | 38          |
| 13.4.1             | Trunk. Description  |              | 38          |
| 13.4.2             | Trunk Side Liner – Left Hand. Renew                           | 76.19.22     | 39          |
| 13.4.3             | Trunk Side Liner – Right Hand. Renew                          | 76.19.23     | 39          |
| 13.4.4             | Trunk Floor Carpet. Renew                                     | 76.19.30     | 39          |
| 13.4.5             | Trunk Front Liner, Renew                                      | 76.19.31     | 39          |
| 13.4.6             | Trunk Seal Retainer, Renew                                    | 76.19.44     | 40          |
| 13.4.7             | Trunk Lid Striker, Adjust                                     |              | 40          |
| 13.4.8             | Trunk Lid Liner, Renew  |              | 40          |
| 13.4.9             | Trunk Seal Retainer, Renew                                    |              | 40          |
| 13.4.10            | Trunk Lid Lock Striker, Renew                                 |              | 40          |
| 13.4.11            | Trunk Lid Lock Barrel. Renew                                  |              | 40          |
| 13.4.12            | Trunk Lid Lock Mechanism, Renew                               |              | 41          |
| 13.3.13            | Trunk Lid Gas Strut. Adjust. Renew                            |              | 41          |
| 13.4.14            | Trunk Lid Hinge, Renew  |              | 41          |
| 13.4.15            | Trunk Rear Liner, Renew                                       |              | 41          |
| 13.5               | Hood  |              | 42          |
| 13.5.1             | Hood Description  |              | 42          |
| 13.5.2             | Plenum Chamber Finisher, Renew                                | 76.10.01     | 42          |
| 13.5.3             | Hinge. Renew  |              | 42          |
| 13.5.4             | Gas Strut, Renew  |              | 43          |
| 13.5.5             | Hood Lock RH or LH, Renew                                     |              | 43          |



## SECTION CONTENTS

| <b>Sub-Section</b> | <b>Title</b>  | <b>SRO</b> | <b>Page</b> |
|--------------------|---|------------|-------------|
| 13.5.6             | Hood lock Control CableRH or LH, Renew                              |            | 43          |
| 13.5.7             | Hood Striker Assembly, Renew  |            | 43          |
| 13.5.8             | Hood lock Release Handle. Renew                                     |            | 43          |
| 13.6               | Glazing (Fixed)   |            | 44          |
| 13.6.1             | Glazing (Fixed). Description  |            | 44          |
| 13.6.2             | Interior Mirror, Renew  |            | 44          |
| 13.6.3             | Sun Visor Mirror Assembly, Renew                                    |            | 44          |
| 13.6.4             | Exterior Mirror, Renew  |            | 44          |
| 13.6.5             | Exterior Mirror Glass, Renew  |            | 44          |
| 13.7               | Carpets   |            | 45          |
| 13.7.1             | Carpets, Description  |            | 45          |
| 13.7.2             | Removal of Stains – General Information                             |            | 45          |
| 13.7.3             | Powder Cleaning – Removal of Small Spillage Stains                  |            | 45          |
| 13.7.4             | Spot Cleaning – Localized Stains                                    |            | 46          |
| 13.7.5             | Carpet Cleaning and Stain Removal Materials                         |            | 47          |
| 13.7.6             | Repair of Damaged Carpet  |            | 47          |
| 13.8               | Seating and Seat Belts  |            | 48          |
| 13.8.1             | Seating, Description  |            | 48          |
| 13.8.2             | Front Manual Seat, Renew  |            | 48          |
| 13.8.3             | Front Seat (Power Operated), Renew                                  |            | 48          |
| 13.8.4             | Front Seat Head Restraint (Power Operated), Renew                   |            | 49          |
| 13.8.5             | Front Seat Head Restraint (Power Operated), Renew                   |            | 49          |
| 13.8.6             | Rear Seat Cushion. Renew  |            | 49          |
| 13.8.7             | Rear Seat Squab, Renew  |            | 49          |
| 13.8.8             | Seat Belts, Description   |            | 50          |
| 13.8.9             | Emergency Locking Retractor/ Automatic Locking Retractor Seat Belts |            | 50          |
| 13.8.10            | Tear Loop Seat Belts, Description                                   |            | 51          |
| 13.8.11            | Front Seat Belt Buckle Unit, Renew                                  |            | 52          |
| 13.8.12            | Front Seat Belt, Renew  |            | 52          |
| 13.8.13            | Rear Inertia Seat Belt, Renew                                       |            | 52          |
| 13.8.14            | Rear, Center, Static Seat Belt, Renew                               |            | 53          |



## I. SERVICE TOOLS & EQUIPMENT

| Illustration    | Jaguar Number | Description                                 | Notes                                |
|-----------------|---------------|---|--------------------------------------|
| not illustrated | JD 188        | Underscuttle pad securing clip removal tool | SRO 76.46.1 1/90 and SRO 76.46.15/90 |
| not illustrated | JD 202        | Fascia center vent removal tool             | SRO 76.46.06                         |

## II. TORQUE TIGHTENING SPECIFICATIONS

| Fixing                                     | Tightening Torque (Nm)       |
|--|------------------------------|
| <b>Fascia</b>                              |                              |
| Instrument pack to support panel           | 1.8                          |
| Fascia to support bracket                  | 22 - 28                      |
| Fascia to console                          | 3                            |
| Tunnel bracket to body                     | 22 - 28                      |
| Bolster to tunnel bracket                  | 1.5                          |
| Instrument pack to fascia                  | 3.0                          |
| Strut to fascia                            | 2.0                          |
| Fascia support strut to body               | 7 - 10                       |
| CPU bracket to fascia                      | 5 - 7                        |
| Fascia demister bracket to fascia          | 1.5                          |
| Fascia and air con. location to body       | 1.0                          |
| Air dist. box duct to air dist. box        | 1.0                          |
| Airbag carrier mounting bracket to fascia  | 5 - 7                        |
| Instrument pack support bracket to fascia  | 5 - 7                        |
| Airbag bracket to fascia                   | 2.0                          |
| Air dist. box to fascia                    | 2.0                          |
| Inst. pack support bracket to fascia       | 5 - 7                        |
| Fascia assembly to body                    | 22 - 28                      |
| Airbag door brackets to fascia             | 5 - 7                        |
| Airbag door bracket to fascia and strut    | 4.0                          |
| Airbag door bracket to door frame assembly | 4.0                          |
| <b>Hood</b>                                |                              |
| Hood lock to body                          | 7 - 10                       |
| Hood buffer assembly                       | 7 - 10                       |
| Gas strut - ball pin to weld nut           | 7 - 10                       |
| Hood lever                                 | 5 - 7                        |
| Clamp - hood adjust cable                  | 6 - 8                        |
| <b>Interior</b>                            |                              |
| Sun Visor fixings                          | 1.8                          |
| Sunblind to parcel shelf                   | Tighten to prevailing torque |
| Sunblind bezel assembly                    | 1.0                          |
| Coat hook                                  | 3.0                          |



| Fixing   | Tightening Torque (Nm) |
|--|------------------------|
| <b>Seat belts</b>  |                        |
| Front tear loop belt buckle to bracket fixing            | 30 - 40                |
| Front belt buckle to bracket fixing                      | 30 - 40                |
| Front belt reel bracket to body fixing                   | 30 - 40                |
| Front belt anchor fixing                                 | 30 - 40                |
| Front belt upper guide fixing                            | 7 - 10                 |
| Height adjuster to 'B' post screws                       | 23 - 27                |
| Height adjuster to seat belt anchor retaining nut        | 30 - 40                |
| Rear inertia belt anchor fixing                          | 30 - 40                |
| Rear inertia belt bracket to body fixing                 | 30 - 40                |
| Rear inertia belt reel securing bracket to body fixing   | 30 - 40                |
| Rear inertia / static belt buckle bracket to body fixing | 30 - 40                |
| Rear static belt / inertia buckle bracket to body fixing | 30 - 40                |
| <b>Sunroof</b>   |                        |
| Sunroof frame to roof                                    | 4 - 5                  |
| Sunroof to frame   | 4 - 5                  |
| <b>Trunk</b>   |                        |
| Compact disc autochanger bracket to body                 | 9 - 11                 |
| Battery clamp to tray                                    | 7 - 10                 |
| Warning triangle lower bracket to trunk lid inner panel  | 1.5                    |
| Trunk lock barrel to lid                                 | 4 - 5                  |
| Trunk latch to lid and striker to body                   | 7 - 10                 |
| Trunk latch actuator to bracket                          | 7 - 10                 |
| Trunk latch actuator mounting to lid                     | 7 - 10                 |
| Electrical carrier box to body                           | 5 - 7                  |
| Loadfloor support block to body                          | 9 - 11                 |
| Trunk seal retainer to body                              | 9 - 11                 |

## 11. SERVICE MATERIALS

| Description                  | Uses  | Notes |
|------------------------------|---|-------|
| 'Fibrefresh' Carpet Shampoo  | Cleaning of water-based stains from carpets         |       |
| '1001' Foam Shampoo          | Cleaning of water-based stains from carpets         |       |
| 'Novatreat'                  | Cleaning of water-based stains from carpets         |       |
| 'Genklene' (Trichloroethane) | Cleaning of grease or oil based stains from carpets |       |
| 'Spot Remover'               | Cleaning of grease or oil based stains from carpets |       |





### 13.1 GENERAL DESCRIPTION

This section covers the following areas of the vehicle body:

- Battery cover
- Carpets – passenger compartment, trunk
- Console – including radio, glovebox
- Doors – frames, sealing, locks, trim, glazing
- Fascia
- Fuel filler flap assembly
- Footrest
- Hood – liners, gas strut, locking,
- Illuminated sunvisor – inc mirror
- Interior trim – trim pads, finishers, veneers
- Mirrors – internal, external
- Rear parcel tray
- Roof console
- Roof lining (headlining)
- Seats – front, rear
- Seat belts – front, rear
- Sliding roof
- Steering column cowl
- Underscuttle pad

Refer to Appendix A4 – Body Systems & Body Repair for information relating to crash–damage repairs and to the following external components: exterior trim, bumpers, windscreen and rear screen, closures and sealing.

Refer to Section 15, Electrical for details of the following motors and solenoids: driver's and interior mirrors, window lift, sunroof, seat / headrest and locking mechanisms (doors, trunk and filler cap).

Refer to Section 15, Electrical and Electrical Diagnostic Manual (EDM) for details of the passenger and driver airbags.





## 13.2 DOORS AND FUEL FILLER FLAP

### 13.2.1 Doors, Description

Doors are of welded, mild steel frames welded to the door panels; sponge rubber primary and secondary seals are mounted on the doors. Internal insulation is provided by a foam water shedder attached to the door by press fitting and double-sided adhesive tape.

Front and rear door armrests are attached to supports riveted to each door frame; the attaching screws are fitted with access covers. Upper and lower trim pads and a door pocket are attached to each of the doors by clips and screws. multi-plug connectors are used to provide a means of connecting the guard lamps, window lift switches and loudspeakers, external mirror and regulator (front doors only), which are housed within the doors.

Central locking is provided subject to market variations: Dead Locking for UK / Europe and Driver only unlock for N America. Door locks are eight disc, bayonet fixing, barrels with integral lock / unlock switches. Keys include 'in-key' transponders which are programmed to the vehicle via the Jaguar Diagnostic System also operate the engine immobilisation system.

**CAUTION:** When removing the door panel water shedder, a foam membrane attached to each door panel by a combination of pressfitting (upper area) and by double-sided tape (bottom area), it is important that the shedder is refitted correctly to maintain the water seal.

It is advisable not to disturb the bottom (taped) portion of the water shedder unless absolutely necessary - it is possible to unclip the top of the shedder and bend it over to gain access to the inner panel.

If it is necessary to disturb the bottom attachment, eg to remove the water shedder from the door panel, the existing water shedder must be discarded and a new one fitted to ensure that the seal is maintained. On refitting, the new water shedder should be pressed onto the door panel at the top and then the adhesive tape backing strip peeled off to enable the shedder to be pressed home at the bottom.

### 13.2.2 front and Rear Door Trim Pad Veneer Panel, Renew

SRO 76.47.11

76.47.12

- Reposition the inner door handle. See Fig. 1.
- Remove the inner handle escutcheon plate blanking plate.
- Undo and remove the inner handle escutcheon plate securing screw.
- Remove the plate and gasket.
- Carefully Undo and remove the veneer panel.
- Undo and remove the retaining clip securing screws.
- Remove the retaining clip assemblies.
- Place the veneer panel aside.
- Place the new veneer panel to the front.
- Fit the retaining clip assemblies.
- Fit and tighten the retaining clip securing screws.
- Fit and fully seat the veneer panel to the door.
- Reposition the inner door handle.
- Fit the gasket and plate over the inner door handle.
- Fit and tighten the escutcheon plate securing screw.
- Refit the blanking plate.

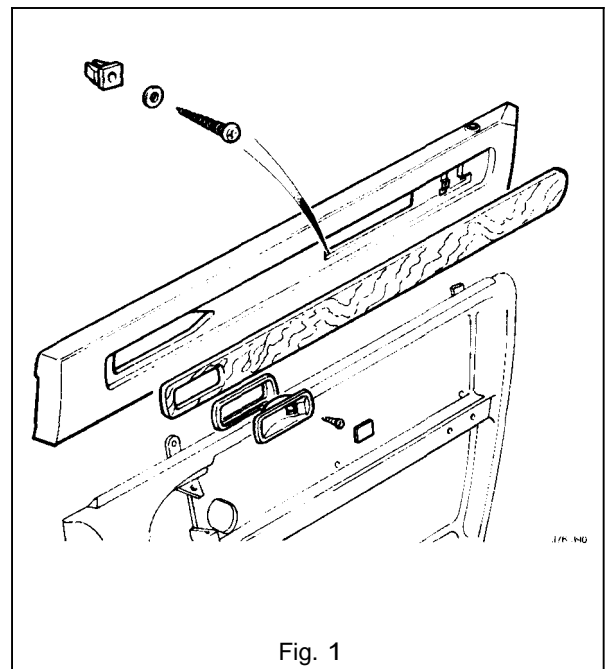



### 13.2.3 Rear Door Upper Trim Pad – Remove For Access And Refit

#### SRO 76.34.05/90

- Remove the rear door trim pad veneer panel, see sub-section 13.2.2.
- Undo and remove the upper trim panel securing screws.
- Lift to release the panel from the door mounting and remove the panel.
- Fit the trim pad and fully seat on the door mounting position.
- Fit and tighten the trim pad securing screws.
- Refit the veneer panel.

### 13.2.4 Rear Door Upper Trim Pad, Renew

#### SRO 76.34.05

- Remove the rear door trim pad veneer panel, see sub-section 13.2.2.
- Undo and remove the upper trim panel securing screws.
- Lift the panel to release from the door mounting and remove the panel.
- Undo and remove the chrome strip securing screws.
- Remove the chrome strip.
- Undo and remove the top channel securing nuts.
- Displace and remove the top channel assembly.
- Place the trim pad aside.
- Place new trim pad to the front.
- Fit the upper channel to the trim pad.
- Fit and tighten the channel securing nuts.
- Fit the chrome strip.
- Fit and tighten the chrome strip securing screws.
- Fit the trim pad and fully seat on the door mounting position.
- Fit and tighten the trim pad securing screws.
- Refit the veneer panel.

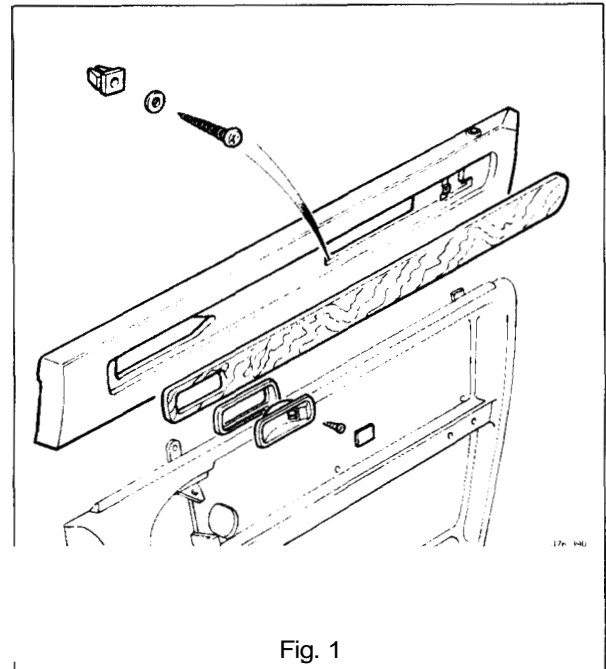

### 13.2.5 Rear Door Window Lift Switch Veneer Panel, Renew

#### SRO 76.47.34

- Displace and remove the window lift assembly end cover trim pad, Fig. 2.
- Undo and remove the veneer panel to switch assembly securing screw.
- Displace and remove the veneer panel from the forward securing clip.
- Place panel aside.
- Fit and fully seat new veneer panel to the forward securing clip.
- Fit and fully tighten the panel securing screw.
- Fit and fully seat the switch assembly end trim pad.

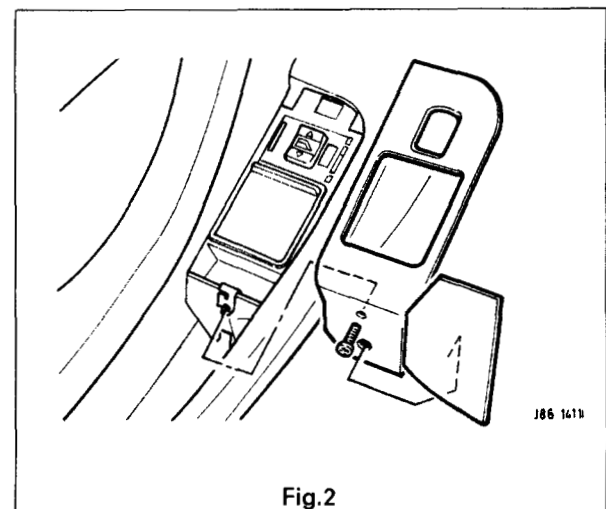



## 13.2.6 Rear Door lower Trim Pad- Remove For Access And Refit

### SRO 76.34.06/90

- Remove the rear door armrest, see sub-section 13.2.8.
- From inside the door pocket, release the puddle lamp (1 Fig. 1) securing quarter turn fastener.
- Disconnect the multi-plugs (1 Fig. 2) and remove the lamp.
- Carefully displace the trim pad (2 Fig. 1) from the door retaining clips.
- Displace trim pad from the upper retaining tang (3 Fig. 1).
- Disconnect the door speaker multi-plug (2 Fig. 2) and the window lift switch multi-plug (3 Fig. 2).
- Feed the lamp harness through the trim pad and lower the trim pad assembly.
- Position the trim pad to the vehicle.
- Feed the puddle lamp harness through the trim pad.
- Connect the window lift switch and speaker multi-plugs.
- Locate the trim pad upper retaining tang.
- Fit and fully seat the trim pad retaining clips.
- Place the puddle lamp to position.
- Connect the lamp multi-plugs.
- Fit and align the puddle lamp to the door pocket and secure with the lamp securing quarter turn fastener.
- Refit the armrest.

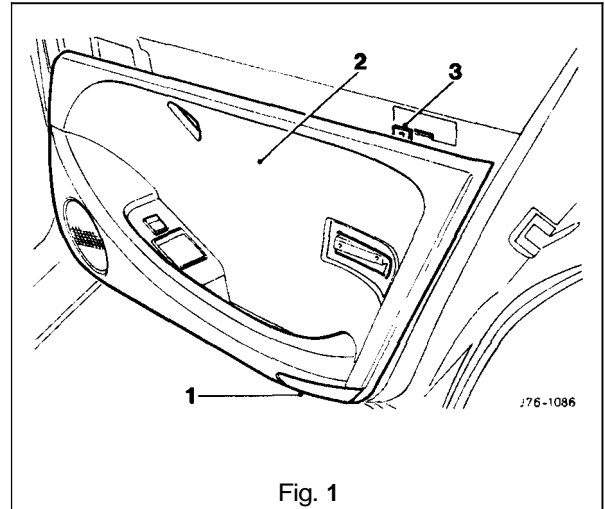

## 13.2.7 Rear Door lower Trim Pad, Renew

### SRO 76.34.06

- Remove the rear door armrest, see sub-section 13.2.8.
- From inside the door pocket, release the puddle lamp (1 Fig. 1) securing quarter turn fastener.
- Disconnect lamp multi-plugs (1 Fig. 2) and remove lamp.
- Displace the trim panel (2 Fig. 1) from door retaining clips.
- Displace trim pad from the upper retaining tang (3 Fig. 1).
- Disconnect the door speaker multi-plug (2 Fig. 2) and the window lift switch multi-plug (3 Fig. 2).
- Feed the lamp harness through the trim pad and lower the trim pad assembly.
- Remove the rear door pocket, see sub-section 13.2.9.
- Displace and remove the retaining clips and remove the trim..
- Place the new door trim pad to the front.
- Fit and fully seat the trim pad retaining clips.
- Refit the rear door pocket.
- Position the trim pad to the vehicle.
- Feed the puddle lamp harness through the trim panel.
- Connect the window lift switch and speaker multi-plugs.
- Locate the trim pad upper retaining tang.
- Fit and fully seat the trim pad retaining clips.
- Place the puddle lamp to position.
- Connect the lamp multi-plugs.
- Fit and align the puddle lamp to the door pocket and secure with the lamp securing quarter turn fastener.
- Refit the armrest.

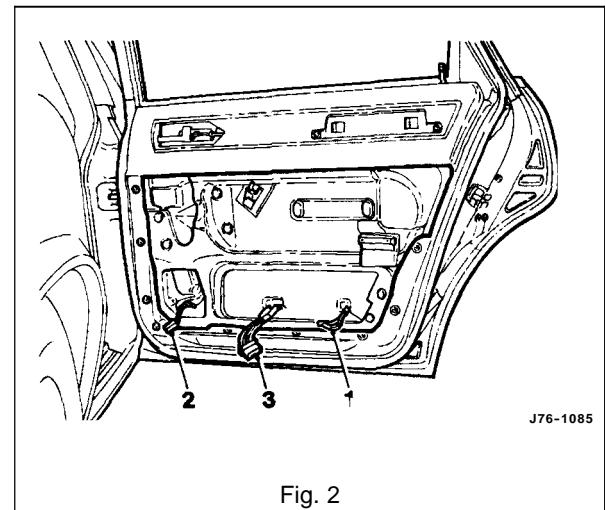



## 13.2.8 Rear Door Armrest, Renew

### SRO 76.34.23

- Displace and remove the armrest securing screw hole plastic finisher covers (1 Fig. 1).
- Undo and remove the armrest securing screws (2 Fig. 1) and remove the armrest assembly.
- Remove the armrest screw hole plastic finishers (3 Fig. 1).
- Undo and remove the chrome finisher securing screws.
- Undo and remove the armrest inner black finisher securing screws.
- Displace and remove the finisher.
- Place the armrest aside.
- Place the new armrest to the front.
- Fit and align the inner trim finisher.
- Fit and tighten the finisher securing screws.
- Fit and align the armrest chrome finisher.
- Fit and tighten the finisher securing screws.
- Fit and seat armrest securing screw hole plastic finishers.
- Position the armrest assembly. Fit and tighten the armrest securing screws.
- Fit and seat the armrest screw hole plastic finisher covers.

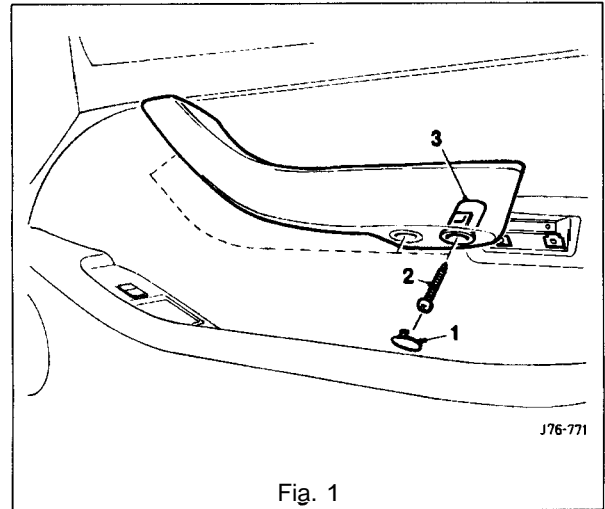

Fig. 1

## 13.2.9 Rear Door Pocket, Renew

### SRO 76.34.28

- Remove the rear door armrest, see sub-section 13.2.8.
- Remove the lower trim pad, see sub-section 13.2.6.
- Undo and remove the rear door pocket to trim pad securing screws (Fig. 2). Remove the door pocket.
- Displace and remove the rear window lift switch assembly end cover trim pad (Fig. 3).
- Undo and remove the veneer panel to switch assembly securing screw (Fig. 3).
- Displace and remove the veneer panel from the forward securing clip (Fig. 3).
- Undo and remove the switch assembly securing screws / nuts (Fig. 3).
- Displace and remove the switch assembly.
- Undo and remove the speaker securing screws and remove the speaker.
- Displace and remove the speaker grille.
- Place the door pocket aside.
- Place new rear door pocket to the front.
- Fit and fully seat the speaker grille.
- Position the speaker and fit the speaker securing screws.
- Fit and align the window lift switch assembly.
- Fit and tighten the switch assembly securing screws / nuts.
- Fit and fully seat the veneer panel to the front securing clip.
- Fit and tighten the veneer panel securing screw.
- Fit and fully seat the switch end cover trim pad.
- Position the door pocket to lower trim pad and fit and tighten the door pocket securing screws.
- Refit the door lower trim pad.
- Refit the rear door armrest.

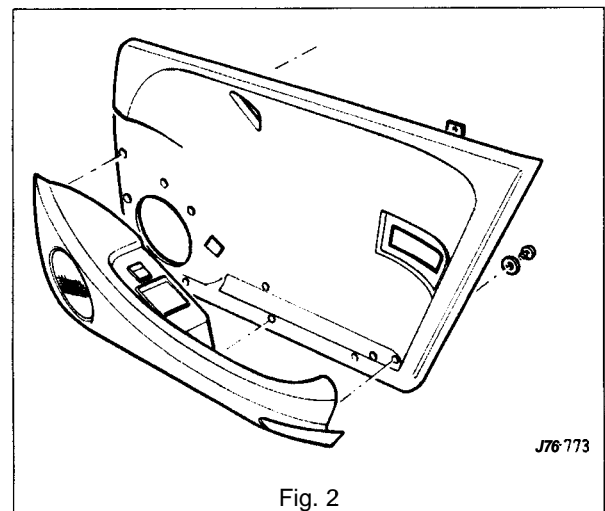

Fig. 2

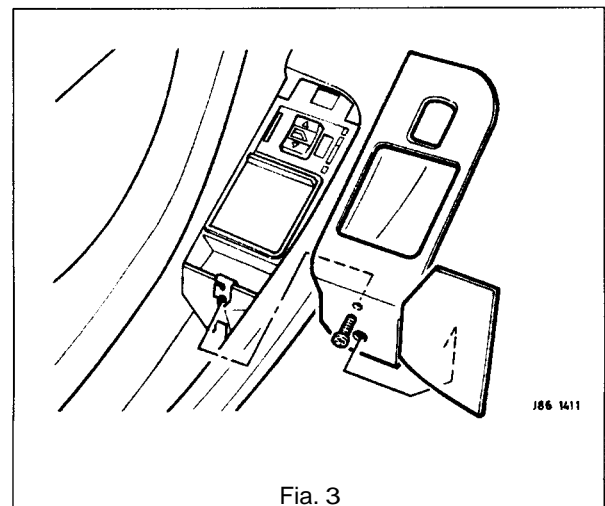

Fig. 3



### 13.2.10 Front Door Upper Trim Pad, Renew

- Disconnect vehicle battery ground lead.
- Remove the front door veneer panel.
- Remove the upper trim pad securing clip and screws.
- Lift the trim pad to release it from the door and remove the inner waist rail seal.
- To refit, carry out reversal of the above procedure.

### 13.2.11 Front Door lower Trim Pad, Renew

- Disconnect vehicle battery ground lead.
- Remove armrest.
- From inside door pocket, release guard retainer, disconnect multi-plug and remove lamp.
- Carefully prise the trim pad away from the door and release from the upper retainer.
- With the trim pad moved for access, disconnect loudspeaker and window lift switch multi-plugs.
- Feed guard lamp harness through aperture and place trim pad on a clean workbench.
- Remove front door pocket and trim pad retainers.
- To refit, carry out reversal of the above procedure. Check the trim pad retainers for damage before refitting.

### 13.2.12 Door lock Barrel, Renew

- Disconnect vehicle battery ground lead.
- Remove the door trim veneer, door upper trim pad, door lower trim pad and door handle.
- Remove the handle assembly to a clean workbench.
- Remove the lock barrel from its bayonet type mounting.
- Carefully remove the barrel components noting the order and position if reassembly is required.
- To refit, carry out reversal of the above procedure, ensuring that the components are lightly greased.

### 13.2.13 Front or Rear Door Lock Striker, Renew

- Note position of striker before removal.
- Remove two screws attaching striker to pillar.
- Remove striker from pillar.
- To refit, carry out reversal of the above procedure, ensuring that the striker is correctly aligned with the door lock before final torque tightening.

### 13.2.14 Front or Rear Door Outer Handle Operating Rod, Renew

- Disconnect vehicle battery ground lead.
- Remove the door trim veneer, door upper trim pad, door lower trim pad.
- Disengage the handle operating rod retaining clip and free the rod from the operating pivot.
- Allow the latch lever to contact the release mechanism, reposition the operating rod and replace the retaining clip.
- Check that the setting is correct by operating the door mechanism.
- To refit, carry out reversal of the above procedure.

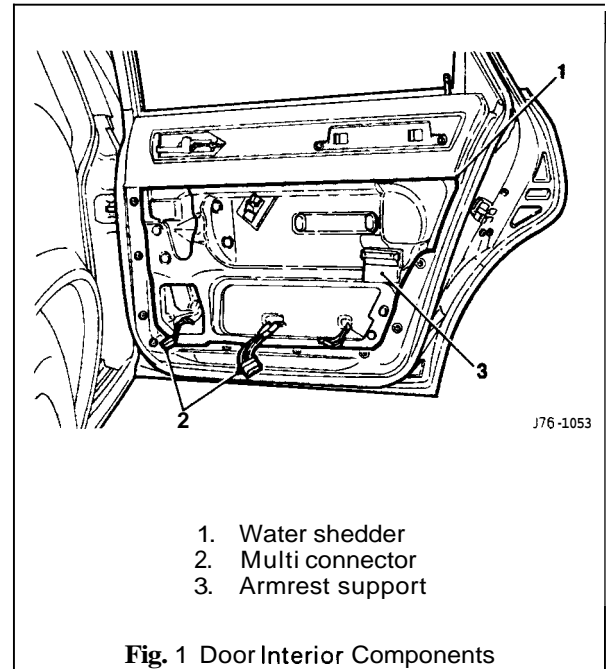



### 13.2.15 Front Armrest, Renew

- Disconnect vehicle battery ground lead.
- Remove access covers to armrest fixings.
- Remove screws securing armrest to support bracket.
- Remove armrest and remove fixing screw inserts from armrest.
- To refit, carry out reversal of the above procedure.

### 13.2.16 Front or Rear Armrest Support, Renew

- Disconnect vehicle battery ground lead.
- Remove door armrest.
- Remove lower trim pad from door.
- Drill out rivets and remove retaining screws from front and rear armrest support brackets.
- Remove drilling debris and swarf.
- Make good any damage to body finish caused by drilling; use zinc primer and body colour.
- To refit, carry out reversal of the above procedure.

### 13.2.17 Front Door Pocket, Renew

- Disconnect vehicle battery ground lead.
- Remove armrest.
- Remove lower trim pad and place on a clean workbench.
- Remove fixings and remove door pocket.
- Remove veneer panel, switch assembly, loudspeaker and loudspeaker grille.
- To refit, carry out reversal of the above procedure.

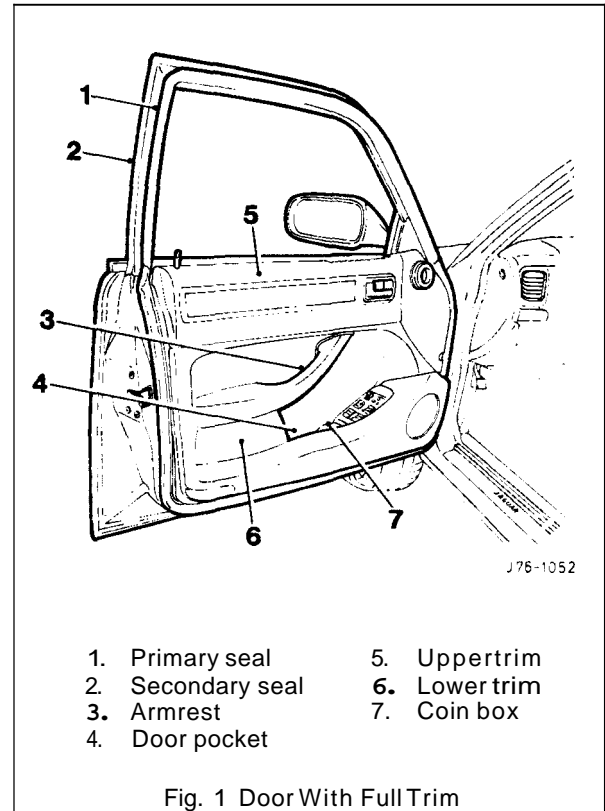



### 13.2.18 Fuel Filler Flap, Description

The fuel filler flap comprises a hinged flap attached to the body decking panel by two M5 nuts; the flap incorporates a rubber buffer, snap-in striker, hinge spring and the fuel cap stowage magnet. The rubber fuel bowl moulding is attached via a steel armature to the body reinforcement panel by five M5 nuts and is retained at the filler neck by a clip. The mating drain tube is fitted with an internal filter.

The fuel filler flap latch mechanism attached to the fuel bowl armature by two M5 nuts, includes a locking pin and actuator which are both serviceable items. The latch actuator operates independently from the central locking system; it is driven directly by the security and locking control module. Locking of the fuel filler flap is achieved only by operation of the key or by the remote rf transmitter.

### 13.2.19 Filler Flap and Hinge, Renew

- Disconnect vehicle battery ground lead.
- With filler cap open, remove hinge securing screws, fuel filler cap and remove flap and hinge assembly.
- To refit, carry out reversal of the above procedure.

### 13.2.20 Filler Cap Retention Magnet, Renew

- Disconnect vehicle battery ground lead.
- With filler flap open, use a blunt flat bladed implement and remove the magnet assembly.

**CAUTION:** Take care not to damage paintwork.

- To refit, carry out reversal of the above procedure.

### 13.2.21 Filler Flap latching Assembly, Renew

- Disconnect vehicle battery ground lead.
- Depress the latching assembly retaining nut and remove the assembly.

**CAUTION:** Take care not to damage paintwork.

- To refit, carry out reversal of the above procedure.

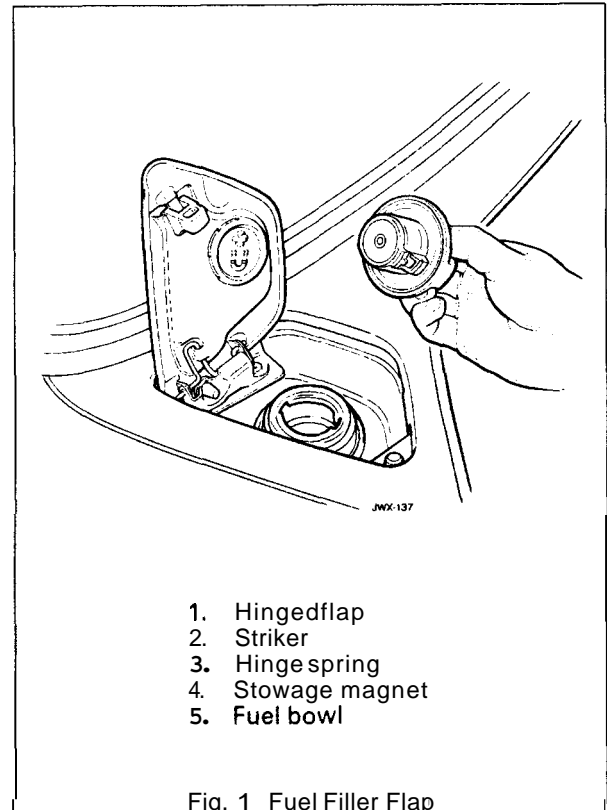



## 13.3 PASSENGER COMPARTMENT

### 13.3.1 Console Assembly – Remove For Access And Refit

#### SRO 76.25.01/90

- Remove the battery cover. Disconnect the battery.
- Remove the drivers side underscuttle pad, see sub-section 13.3.19.
- Remove the passenger side underscuttle pad, see sub-section 13.3.20.
- Remove the console ashtray, see sub-section 13.3.28.
- Remove the console finisher veneer panel, see sub-section 13.3.24.
- Remove the radio console, see sub-section 13.3.10.
- Remove the fascia center veneer panel, see sub-section 13.3.23.
- Undo and remove the console upper securing screws.
- Displace and reposition the rear air distribution outlet box.
- Disconnect the cigar lighter multi-plug (where fitted).
- Disconnect the security system valet switch harness multi-plug.
- Remove the rear air distribution outlet box.
- Undo and remove the center console rear mounting securing screw.
- Displace and remove the console assembly and place on the bench.
- Place the console in position in the vehicle.
- Fit and tighten the console front securing screws.
- Fit and tighten the console rear securing screw.
- Reconnect the security system valet switch multi-plug.
- Place the air distribution outlet in position.
- Connect the rear cigar lighter harness multi-plug (where fitted).
- Fit and fully seat the air distribution outlet.
- Refit the fascia center veneer panel.
- Refit the radio console.
- Refit the console finisher veneer panel.
- Refit the console ashtray.
- Refit the underscuttle pads.
- Reconnect the battery. Refit the battery cover.





### 13.3.2 Console Assembly – Renew (Daimler / VDP)

#### SRO 76.25.01/50

- Remove the battery cover. Disconnect the battery.
- Remove the console rear extension finisher, see sub-section 13.3.5.
- Remove the console rear extension veneer panel, see sub-section 13.3.27.
- Remove the console rear extension, see sub-section 13.3.6.
- Remove the drivers side underscuttle pad, see sub-section 13.3.19.
- Remove the passenger side underscuttle pad, see sub-section 13.3.20.
- Remove the console ashtray, see sub-section 13.3.28.
- Remove the console finisher veneer panel, see sub-section 13.3.24.
- Remove the radio console, see sub-section 13.3.10.
- Remove the fascia center veneer panel, see sub-section 13.3.23.
- Undo and remove the console upper securing screws.
  - Displace and reposition the rear air distribution outlet box.
  - Disconnect the cigar lighter multi-plug (where fitted).
  - Disconnect the security system valet switch harness multi-plug.
  - Remove the air distribution outlet box.
- Undo and remove the center console rear mounting securing screw.
  - Displace and remove the console assembly and place on the bench.
  - Displace and remove the spire clips from the console assembly.
  - Open the glove box lid.
    - Remove the glove box lid latch.
    - Undo and remove the glove box lid rear securing screws.
    - Displace and remove the glove box lid/glove box assembly.
    - Place the console aside.
    - Place the new console to the front.
    - Fit and align the glove box lid/glove box assembly.
    - Fit but do not fully tighten the glove box lid securing screw.
    - Close the glove box lid and check the adjustment.
    - Open and adjust the lid.
    - Finally tighten the securing screws.
    - Fit and align the glove box lid latch.
    - Close the glove box lid.
    - Fit and align the spire clips to the console.



- Place the console in position in the vehicle.
- Fit and tighten the front securing screws.
- Fit and tighten the rear securing screw.
- Reconnect the security system valet switch multi-plug.
- Place the air distribution outlet in position.
- Connect the rear cigar lighter harness multi-plug (where fitted).
- Fit and fully seat the air distribution outlet.
- Refit the fascia center veneer panel.
  - Refit the radio console.
  - Refit the console veneer panel.
  - Refit the console ashtray.
  - Refit the console finisher.
- Refit the underscuttle pads.
  - Refit the console extension.
  - Refit the console extension veneer panel.
  - Refit the console rear extension finisher.
- Reconnect the battery. Refit the battery cover.



### **13.3.3 Console Assembly – Remove For Access And Refit (Daimler/ VDP)**

#### **SRO 76.25.01/91**

- Remove the battery cover. Disconnect the battery.
- Remove the console rear extension finisher, see sub-section 13.3.5.
- Remove the console rear extension veneer panel, see sub-section 13.3.27.
- Remove the console rear extension, see sub-section 13.3.6.
- Remove the drivers side underscuttle pad, see sub-section 13.3.19.
- Remove the passenger side underscuttle pad, see sub-section 13.3.20.
- Remove the console ashtray, see sub-section 13.3.28.
- Remove the console finisher veneer panel, see sub-section 13.3.24.
- Remove the radio console, see sub-section 13.3.10.
- Remove the fascia center veneer panel, see sub-section 13.2.23.
  - Undo and remove the console upper securing screws.
- Displace and reposition the rear air distribution outlet box.
- Disconnect the cigar lighter multi-plug (where fitted).
- Disconnect the security system valet switch harness multi-plug.
- Remove the air distribution outlet box.
- Undo and remove the center console rear mounting securing screw.
- Displace and remove the console assembly and place on the bench.
- Place the console in position in the vehicle.
- Fit and tighten the front securing screws.
- Fit and tighten the rear securing screw.
- Reconnect the security system valet switch multi-plug.
- Place the air distribution outlet in position.
- Connect the rear cigar lighter harness multi-plug (where fitted).
- Fit and fully seat the air distribution outlet.
- Refit the center vent veneer panel assembly.
- Refit the radio console.
- Refit the console veneer panel.
- Refit the console ashtray.
- Refit the console finisher.
- Refit the underscuttle pads.
- Refit the console extension.
- Refit the console extension veneer panel.
- Refit the console rear finisher.
- Reconnect the battery. Refit the battery cover.



### 13.3.4 Console Assembly, Renew

SRO 76.25.01

- Remove the battery cover. Disconnect the battery.
- Remove the drivers side and passenger side underscuttle pads, see subsections 13.3.19 and 13.3.20.
- Remove the console ashtray, see sub-section 13.3.28.
- Remove the console finisher veneer panel, see sub-section 13.3.24.
- Remove the radio console, see sub-section 13.3.10.
- Remove the fascia center veneer panel, see sub-section 13.3.23.
- Undo and remove the console upper securing screws.
- Displace and reposition the rear air distribution outlet box.
- Disconnect the cigar lighter multi-plug (where fitted).
- Disconnect the security system valet switch multi-plug.
- Remove the rear air distribution outlet box.
- Disconnect the security system valet switch multi-plug.
- Remove the rear air distribution outlet box.
- Undo and remove the center console rear mounting securing screw.
- Remove the console assembly and place on the bench.
- Displace and remove spire clips from console assembly.
- Open the glove box lid.
- Remove the glove box lid latch.
- Undo and remove glove box lid rear securing screws.
- Displace and remove glove box lid / glove box assembly.
- Place the console aside.
- Place the new console to the front.
- Fit and align the glove box lid / glove box assembly.
- Fit but do not fully tighten the glove box lid securing screw.
- Close the glove box lid and check the adjustment.
- Open and adjust the glove box lid.
- Finally tighten the lid securing screws.
- Fit and align the glove box lid latch.
- Close the glove box lid.
- Fit and align the spire clips to the console.
- Place the console in position in the vehicle.
- Fit and tighten the console front securing screws.
- Fit and tighten the console rear securing screw.
- Reconnect the security system valet switch multi-plug.
- Place the air distribution outlet in position.
- Connect rear cigar lighter harness multi-plug (if fitted).
- Fit and fully seat the air distribution outlet.
- Refit fascia center veneer panel.
- Refit the radio console.
- Refit the console finisher veneer panel.
- Refit the console ashtray.
- Refit underscuttles.
- Reconnect the battery.
- Refit the battery cover.



### 13.3.5 Console Rear Extension Finisher, Renew

#### SRO 76.25.04

- Carefully displace and remove the motif from the extension finisher (Fig. 1).
- Undo and remove the finisher securing screw.
- Displace and remove the finisher.
- Fit and seat the new finisher to the extension.
- Fit and tighten the finisher securing screw.
- Apply suitable adhesive to the back of the motif.
- Fit and seat the motif to the finisher.

### 13.3.6 Console Rear Extension, Renew

#### SRO 76.25.05

- Remove the console rear extension finisher, see sub-section 13.3.5 above and Fig. 1.
- Remove the console rear extension veneer panel, see sub-section 13.3.27.
- Undo and remove the extension securing screws.
- Displace and remove the extension assembly.
- Remove the screw and peg inserts.
- Place the extension aside.
- Place the new extension to the front.
- Fit the screw and peg inserts.
- Fit and align the extension assembly to the floor.
- Fit and tighten the extension securing screws.
- Refit the rear extension veneer panel.
- Refit the rear extension finisher.

### 13.3.7 Selector Trim Finisher, Renew (3.2 Liter)

#### SRO 76.25.07

- Carefully displace and remove the gearshift aperture plastic finisher, Fig. 2.
- Displace and remove the selector trim finisher.
- Fit and fully seat the new selector trim finisher.
- Fit and fully seat the gearshift aperture plastic finisher.

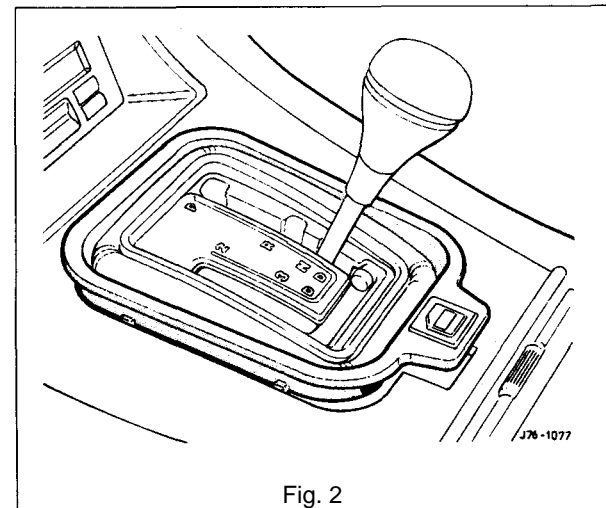
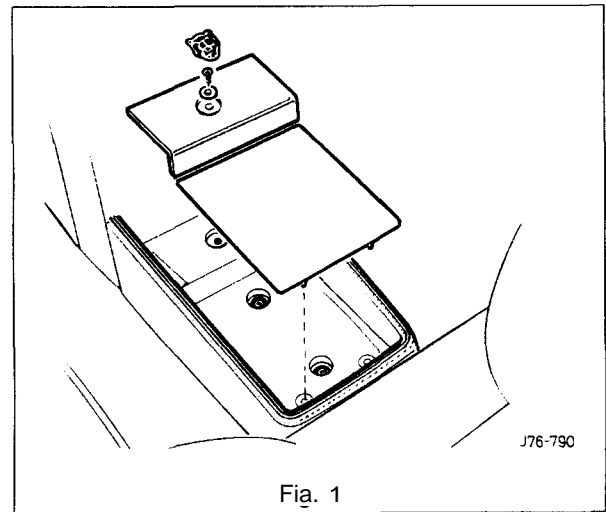



### 13.3.8 Selector Trim Finisher, Renew (4.0 Liter, 4.0 Liter SC And 6.0 Liter)

SRO 76.25.07

- Remove the mode switch (Fig. 1).
- Remove the mode switch finisher (Fig. 2).
- Displace and remove the selector trim finisher.
- Refit the mode switch finisher.
- Refit the mode switch.

### 13.3.9 Mode Switch Finisher, Renew

SRO 76.25.09

- Remove the mode switch (Fig. 1).
- Carefully displace and remove the finisher (Fig. 2).
- Fit and fully seat the new finisher.
- Refit the mode switch.

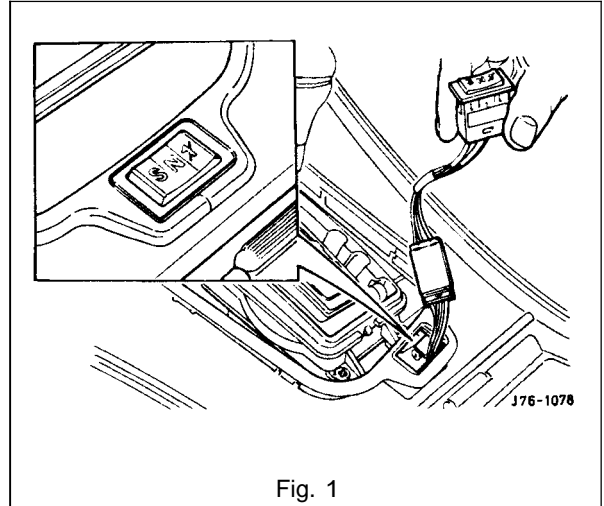

Fig. 1

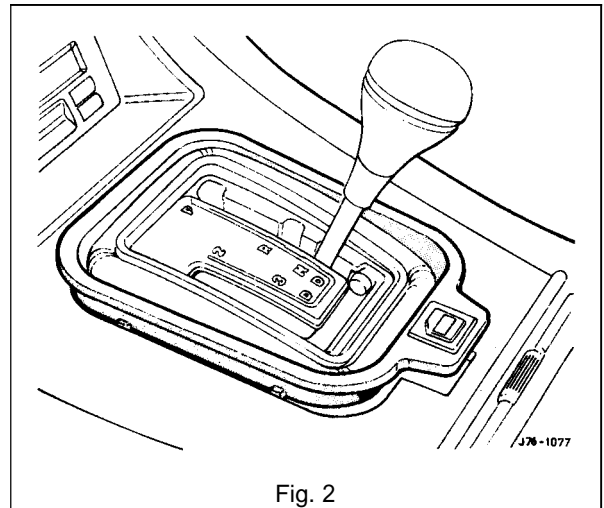

Fig. 2



### 13.3.10 Radio Console, Renew

#### SRO 76.25.15

- Remove the battery cover. Disconnect the battery.
- Remove the console ashtray, see subsection 13.3.28.
- Remove console veneer panel, see subsection 13.3.24.
- Remove the gear selector ident plate securing screws.
- Carefully reposition the radio console assembly from the mounted position.
- Disconnect the assembly harness multi-plugs.
- Disconnect the antenna co-axial connector.
- Undo and remove the ground lead to radio securing nut.
- Reposition the ground lead from radio stud.
- Disconnect the radio harness multi-plugs.
- Reposition the radio harness from the center console.
- Displace the radio console assembly.
- Remove the radio assembly from the console.
- Remove the radio retaining plate.
- Undo and remove the air conditioning control module securing screws.
- Displace and remove the module.
- Undo and remove switch/clock module securing screws.
- Displace and remove the module assembly.
- Place the radio console aside.
- Place the new radio console to the front.
- Fit and fully seat the switch/clock module to the console.
- Fit and tighten the module securing screws.
- Fit and fully seat air conditioning module to the console.
- Fit and tighten the securing screws.
- Fit and fully seat the radio mounting plate to the console.
- Place the radio console to the center console position.
- Place the radio to the center console position.
- Route the radio harness / multi-plugs through the radio console into the center console position.
- Connect the radio harness multi-plugs.
- Connect the radio console harness multi-plugs.
- Route the radio ground and antenna leads through the radio console.
- Fully seat the radio console in the mounted position.
- Fit and tighten the securing screws.
- Reposition the ground lead to radio securing stud.
- Fit and tighten the securing nut.
- Connect the antenna co-axial to the radio.
- Reposition the excess harness / leads into the radio mounting hole, ensuring that the harnesses are positioned to allow the radio to be pushed fully home.
- Fully seat the radio into the console.
- Reposition and fit the selector ident plate.
- Fit and tighten the ident plate securing screws.
- Refit the console veneer panel.
- Refit the console ashtray.
- Reconnect the battery. Refit the battery cover.



### 13.3.11 Console Glove Box, Renew

#### SRO 76.25.16

- Remove the console glove box lid, see subsection 13.3.12.
- Undo and remove the glove box / ashtray securing screws.
- Carefully displace the ashtray upwards for access.
- Displace and remove the ashtray lid catch.
- Displace and reposition the glove box assembly.
- Disconnect the security valet switch harness multi-plug.
- Remove the glove box.
- Place the glove box to the front.
- Displace and remove the valet switch.
- Displace and remove the glove box lid checkarm.
- Displace and remove the glove box lid checkarm guide.
- Place the glove box aside.
- Place the new glove box to the front.
- Fit and fully seat the checkarm guide to the glove box.
- Fit and align the checkarm to the glove box.
- Fit and fully seat the valet switch to the glove box.
- Align and affix a security sticker to the glove box.
- Align and affix a cassette storage foam pad.
- Place the glove box assembly into position.
  - Reconnect the valet switch harness multi-plug.
  - Fit and fully seat the glove box assembly.
  - Fit and align the lid latch.
  - Reposition and fit the ashtray.
  - Fit and tighten the ashtray securing screws.
  - Refit the glove box lid.





### 13.3.12 Console Glove Box Lid, Renew

#### **SRO 76.25.18**

- Open the console glove box lid.
- Undo and remove the glove box lid checkarm to lid securing screw.
- Reposition the checkarm.
- Undo and remove the glove box lid to console securing screws.
- Displace and remove the glove box lid assembly.
- Place the lid assembly to the front.
- Undo and remove the lid inner securing screws.
- Displace and remove the lid inner.
- Displace and remove the lid latch release lever.
- Undo and remove the lid hinge securing screw.
- Displace and remove the hinge.
- Undo and remove the lid latch securing screw.
- Displace and remove the lid latch.
- Displace and remove the lid latch return spring.
- Place the lid aside.
- Place the new lid to the front.
- Fit and align the latch return spring to the lid.
- Fit and align the lid latch, ensuring that the latch leg locates behind the spring.
- Fit and tighten the latch securing screw.
- Fit and align the lid hinge.
- Fit and tighten the lid hinge securing screw.
- Fit and align the lid latch release lever.
- Fit and fully seat the lid inner to the lid.
- Fit and tighten the inner lid securing screws.
- Fit and align the lid assembly to the console.
- Fit and tighten the lid to console securing screws.
- Align the lid checkarm to the lid.
- Fit and tighten the checkarm securing screw.
- Close the glove box lid.



### **13.3.13 Console Glove Box Lid Hinge, Renew**

#### **SRO 76.25.20**

- Open the console glove box lid.
- Undo and remove the glove box lid checkarm to lid securing screw.
- Reposition the checkarm.
- Undo and remove the glove box lid to console securing screws.
- Displace and remove the glove box lid assembly.
- Place the lid assembly to the front.
- Undo and remove the lid inner securing screws.
- Displace and remove the lid inner.
- Displace and remove the lid latch release lever.
- Undo and remove the lid hinge securing screw.
- Displace and remove the hinge.
- Fit and align the new lid hinge.
- Fit and tighten the lid hinge securing screw.
- Fit and align the lid latch release lever.
- Fit and fully seat the lid inner to the lid.
- Fit and tighten the inner lid securing screws.
- Fit and align the lid assembly to the console.
- Fit and tighten the lid to console securing screws.
- Align the lid checkarm to the lid.
- Fit and tighten the checkarm securing screw.
- Close the glove box lid.

### **13.3.14 Cupholder Trim Panel, Renew**

#### **SRO 76.25.21**

- Open the cupholder.
- Undo and remove the cupholder trim panel securing screws.
- Displace and remove the trim panel assembly by releasing the lower edge and then displacing upwards.
- Carefully fit and fully seat the new trim panel.
  - Ensure the panel is correctly seated to the base.
  - Fit and tighten the trim panel securing screws.
- Close the cupholder.



### 13.3.15 *Cupholder, Renew*

#### **SRO 76.25.22**

- Remove the cupholder trim panel, see sub-section 13.3.14.
- Displace and reposition the cupholder assembly from base (cupholder remains captive by spring).
- Using a suitable hook, disconnect the spring from the base and remove the cupholder.
- Disconnect the return spring from the cupholder.
- Place the cupholder aside.
- Place the new cupholder to the front.
- Connect the return spring to the cupholder.
- Place the cupholder into position.
- Using a suitable hook tool, connect the return spring to the base.
- Reposition and fit the cupholder assembly to the base.
- Refit the cupholder trim panel.

### 13.3.16 *Cupholder Latch, Renew*

#### **SRO 76.25.23**

- Remove the console glove box lid, see sub-section 13.3.12.
- Undo and remove the inner lid securing screws.
- Displace and remove the inner lid.
  - Open the cupholder.
  - Undo and remove the cupholder latch securing screw.
  - Displace and remove the latch assembly.
  - Fit and align the new latch assembly to the lid.
  - Fit and tighten the latch securing screw.
  - Fit and align the lid inner to the lid.
  - Fit and tighten the inner lid securing screws.
  - Close the cupholder.
  - Refit the the console glove box lid.



## 13.3.17 Fascia Board, Renew

### SRO 76.46.01

- Remove the battery cover and disconnect the battery.
- Remove the drivers side and passenger side underscuttle pads, see sub-sections 13.3.19 and 13.3.20.
- Remove the drivers airbag module, see section 15.5.
- Remove the steering wheel, section 10.
- Remove the drivers side and passenger side fascia closing panels, see sub-sections 13.3.22 and 13.3.21.
- Remove the fascia center veneer panel, see subsection 13.3.23.
- Remove the fascia board for access, see subsection 13.3.17.
- Disconnect the air conditioning differential potentiometer harness multi-plug.
- Remove the differential potentiometer assembly.
- Displace and reposition the through panel connectors from the fascia assembly.
- Displace the fascia vent motor / gearbox assemblies harness multi-plug from the mounting bracket.
- Disconnect and reposition the fascia harness to console harness multi-plug from the mounting bracket.
- Disconnect the BPU harness multi-plugs.
- Remove the tiestraps securing the harness to the fascia.
- Reposition the fascia on a bench.
- Displace and reposition the solar sensor assembly from the fascia.
- Disconnect the solar sensor harness multi-plug.
- Remove the solar sensor assembly.
- Undo and remove the defrost vents securing screws.
- Displace and reposition the defrost vent assemblies.
  - Disconnect the tweeter speaker harness multi-plugs.
  - Remove the defrost vent assemblies.
  - Displace the fascia harness grommet from the fascia.
  - Route the harness through the aperture.
- Remove the fascia harness assembly.
  - Undo and remove passenger airbag deployment door to fascia securing bolts (one bolt is removed with the fascia).
  - Displace and remove the deployment door assembly.
  - Undo and remove the passenger airbag module to fascia securing bolts.
  - Displace and remove the airbag module assembly.
  - Undo and remove the airbag module / BPU mounting bracket assembly to fascia securing nuts / bolts.
- Displace and remove the mounting bracket assembly.
  - Retrieve the spacing washers.
  - Displace and remove the side vent outlets from the fascia.
  - Displace and remove the side vent ducts securing clips.
  - Displace and remove the side vent ducts.
  - Undo and remove the center vent flap assembly to fascia securing nuts.
  - Displace and remove the center vent flap assembly.
- Undo and remove fascia location bracket securing nuts.
- Displace and remove the location bracket.



- Undo and remove the defrost vents clip location bracket securing screws.
- Displace and remove the clip location brackets.
- Remove the defrost vent spire clips from the fascia.
- Place the fascia aside.
  - Place a new fascia on the bench.
  - Fit and fully seat the defrost vent spire clips.
  - Fit and align the defrost vent clip location brackets.
  - Fit and tighten the location brackets securing screws.
  - Fit and align the fascia location brackets to the fascia.
  - Fit and align the location bracket securing nuts.
  - Fit and align the center vent flap assembly.
  - Fit and tighten the flap assembly securing nuts.
  - Fit and align the side vent ducts to the fascia assembly.
  - Fit and fully seat the side vent ducts securing clips.
  - Fit and fully seat the side vent outlets to the fascia.
- Fit and align the airbag module / BPU mounting bracket assembly and align the spacers.
  - Fit and tighten the airbag module / BPU mounting bracket securing nuts / bolts.
  - Fit and align the airbag module to the fascia.
  - Fit and tighten the airbag module securing bolts.
  - Fit and align the airbag deployment door assembly to the fascia.
  - Fit but do not fully tighten the door securing bolts.
  - Align the door assembly to the fascia.
  - Finally tighten the door securing bolts.
- Position the harness. Route the harness speaker / solar sensor multi-plugs through the aperture in the fascia.
  - Fully seat the harness grommet to the fascia aperture.
  - Route the tweeter speaker harnesses along the defrost vent aperture.
  - Place the defrost vent assemblies to the fascia.
  - Connect the speaker harness multi-plug to the speakers.
- Reposition and fit the vent assemblies to the fascia.
  - Fit and tighten the vent securing screws.
- Place the solar sensor assembly to the fascia.
  - Reconnect the solar sensor harness multi-plug.
  - Fully seat the solar sensor assembly to the fascia.
- Reposition the fascia assembly on the bench.
  - Secure the harness to the fascia assembly using tie straps.
  - Reconnect the BPU harness multi-plugs.
  - Reposition and fit the fascia harness to console harness multi-plug to the mounting bracket.
- Reconnect the fascia vent motor / gearbox assemblies harness multi-plug.



- Reposition and fit the motor / gearbox assemblies harness multi-plug to the mounting bracket.
- Fully seat the through panel connectors to the fascia.
- Place the air conditioning differential potentiometer to the fascia and route the differential potentiometer harness through the vent aperture.
- Reconnect the differential potentiometer harness multi-plug.
- Refit the fascia board.
  - Refit the center veneer panel.
  - Refit the fascia closing panels.
  - Refit the steering wheel.
  - Refit the drivers airbag module.
  - Refit the underscuttle pads.
  - Reconnect the battery and refit the battery cover.



### 13.3.18 Fascia Board – Remove For Access And Refit

#### SRO 76.46.01/90

- Remove the battery cover. Disconnect the battery.
- Remove the drivers side and passenger side underscuttle pads, see sub-sections 13.3.19 and 13.3.20.
- Remove the drivers airbag module, see section 15.5.
- Remove the steering wheel, section 10.
- Remove the drivers side fascia closing panel, see sub-section 13.3.22.
- Remove the passenger side fascia closing panel, see sub-section 13.3.21.
- Remove the fascia center veneer panel, see subsection 13.2.23.
- Undo and remove the fascia tie bar securing nuts.
- Displace the tie bars.
- Undo and remove the instrument housing/fascia switchpack securing screws.
- Reposition the multi-plug mounting bracket.
- Disconnect the steering column control module multi-plugs.
- Disconnect the fascia switchpack harness multi-plugs.
- Displace and reposition the instrument pack for access.
- Disconnect the instrument pack harness multi-plugs.
- Remove the instrument pack / fascia switchpack assembly.
- Disconnect the right hand fascia harness to cabin harness multi-plug.
- Disconnect the column switchgear and column motors harness multi-plug.
- Disconnect the ignition switch harness multi-plug.
- Disconnect the exciter coil harness multi-plug.
- Disconnect the speaker tweeter harness multi-plug.
- Disconnect the speed control control module harness multi-plug.
- Undo and remove the fascia to center console securing screws.
- Displace and remove the passenger side outlet duct.
- Disconnect the fascia harness to console harness multi-plugs.
- Disconnect the left hand fascia harness to cabin harness multi-plug.
- Undo and remove the fascia ground eyelets to body securing nut.
- Displace and reposition the ground eyelets from the stud.
- Displace and reposition the airbag control module from the mounting bracket.
- Undo and remove the fascia assembly lower securing nut.
- Undo and remove the fascia outer body bracket to fascia securing bolts.
- Carefully displace the fascia rearwards.



- From behind the fascia passenger side, disconnect the passenger airbag harness multi-plug.
- With assistance, remove the fascia from the vehicle and place on a suitably protected bench.
- Place the fascia in position in the vehicle with the center location peg correctly engaged.
- Reconnect the passenger airbag module harness multi-plug.
- Carefully fit and align the fascia to the mounting position.
- Fit and tighten the fascia to outer body brackets securing bolts.
- Fit and tighten the fascia assembly lower securing nut.
- Reposition and fit the airbag control module to the mounting bracket.
- Reposition and fit the fascia harness ground eyelets to the ground stud.
- Fit and tighten the ground eyelet securing nut.
- Reconnect the left hand fascia harness to cabin housing harness multi-plug.
- Reconnect the fascia harness to console harness multi-plugs.
- Fit and align the passenger side outlet duct.
- Fit and tighten the fascia to console securing screws.
- Reconnect the speed control harness multi-plug.
- Reconnect the speaker tweeter harness multi-plug.
- Reconnect the exciter coil harness multi-plug.
- Reconnect the column switchgear and column motor harness multi-plugs.
- Reconnect the right hand fascia harness to cabin harness multi-plug.
- Place the instrument pack / fascia switchpack in position.
- Reconnect the instrument pack harness multi-plugs.
- Reposition and fit the instrument pack assembly to the fascia.
- Reconnect the fascia switchpack harness multi-plugs.
- Reconnect the steering column harness multi-plugs.
- Reposition and fit the switchpack harness multi-plug mounting bracket.
- Fit and tighten the instrument pack/ switchpack securing bolts.
- Fit and align the fascia tie bars.
- Fit and tighten the tie bar securing nuts.
- Refit the center veneer panel.
- Refit the fascia closing panels.
  - Refit the steering wheel.
  - Refit the drivers airbag module.
  - Refit the underscuttle pads.
- Reconnect the battery and refit the battery covers.





### 13.3.19 Underscuttle Pad – Drivers Side, Remove For Access And Refit

#### SRO 76.46.11/90

- Motor the drivers seat fully rearwards.
- Undo and remove the underscuttle pad securing screws (1 Fig. 1).
- Using special tool JD 188 (2 Fig. 1), displace securing clip.
- Displace and reposition the underscuttle pad assembly (3 Fig. 1).
- Disconnect the air conditioning aspirator multi-plug.
- Remove the underscuttle pad.
- Place the underscuttle pad assembly in position.
- Connect the air conditioning aspirator multi-plug.
- Reposition the underscuttle pad.
- Secure the underscuttle pad with clip and align the securing screw holes.
- Fit and tighten the underscuttle pad securing screws.
- Motor the seat to the original position.

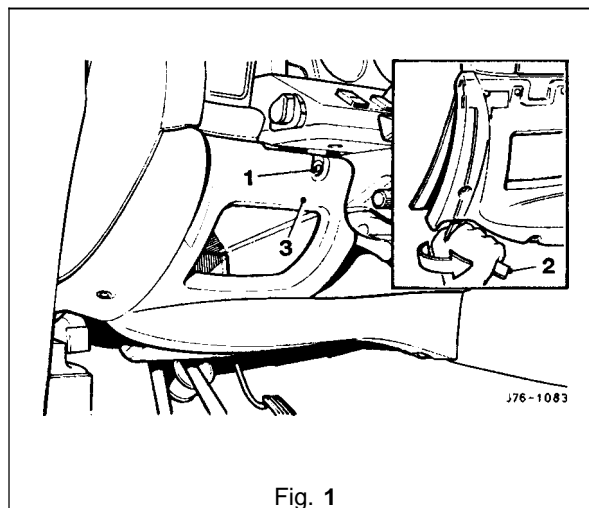

Fig. 1

### 13.3.20 Underscuttle Pad – Passenger Side, Remove For Access And Refit

#### SRO 76.46.15/90

- Motor the passenger seat fully rearwards.
- Undo and remove the underscuttle pad securing screws.
- Using special tool JD 188, displace the securing clip.
- Displace and remove the underscuttle pad.
- Place the underscuttle pad assembly in position.
  - Secure the underscuttle pad with clip and align the securing screw holes.
- Fit and tighten the underscuttle pad securing screws.
- Motor the seat to the original position.



### 13.3.21 Fascia Closing Panel – Passenger Side, Renew

#### SRO 76.46.27

- Remove for access the passenger side underscuttle pad, see sub-section 13.3.20.
- Undo and remove the closing panel to fascia support bracket fir-tree fixing (Fig. 1).
- Displace and remove the closing panel.
- Remove the draught welt.
- Place the panel to the front.
- Displace and remove the end panel securing clip.
- Place new closing panel to the front.
- Fit and fully seat the end panel securing clip.
- Fit and fully seat the end panel to the vehicle.
- Fit and tighten the end panel to fascia support bracket clip.
- Refit the underscuttle pad.

### 13.3.22 Fascia Closing Panel – Drivers Side, Renew

#### SRO 76.46.28

- Remove for access the drivers side underscuttle pad, see sub-section 13.2.19.
- Undo and remove the closing panel to fascia support bracket securing nut (Fig. 1).
- Displace and remove the closing panel.
- Place the panel to the front.
- Displace and remove the end panel securing clip.
- Place new closing panel to the front.
- Fit and fully seat the end panel securing clip.
- Fit and fully seat the end panel to the vehicle.
- Fit and tighten the end panel to fascia support bracket securing nut.
- Refit the underscuttle pad.

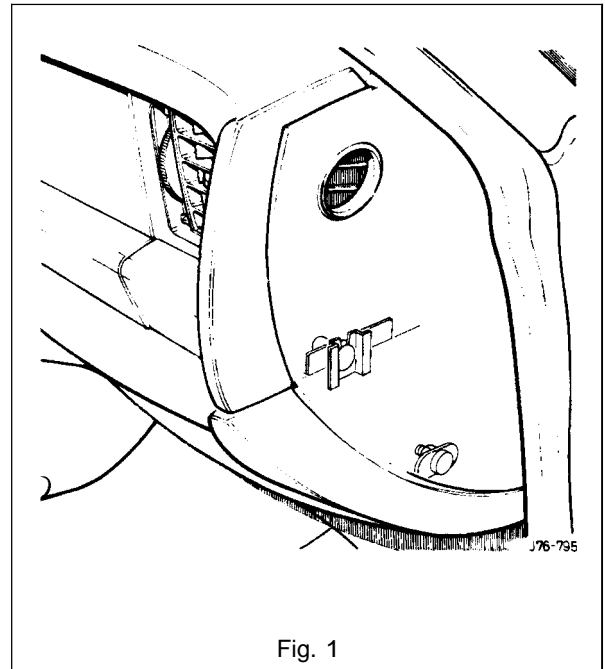

Fig. 1



### 13.3.23 fasciaCenter Veneer Panel, Renew

#### SRO 76.47.06

- Fit and align the special tool JD 202 to the center vent assembly. See Fig. 1.
- Displace and reposition the center vent assembly.
- Remove the special tool from the vent.
- Displace and remove the center vent assembly from the variable differential control potentiometer.
- Place the center vent assembly on a bench covered with a suitable cloth.
- Remove and discard the veneer panel to center vent assembly securing clips.
- Displace and remove the veneer panel from the center vent.
- Fit and align the new veneer panel to the center vent.
- Fit and fully seat the veneer panel securing clips.
- Place the center vent assembly to the vehicle.
- Fit and fully seat the vent assembly to differential control potentiometer.
- Fit and fully seat the center vent assembly to the fascia.

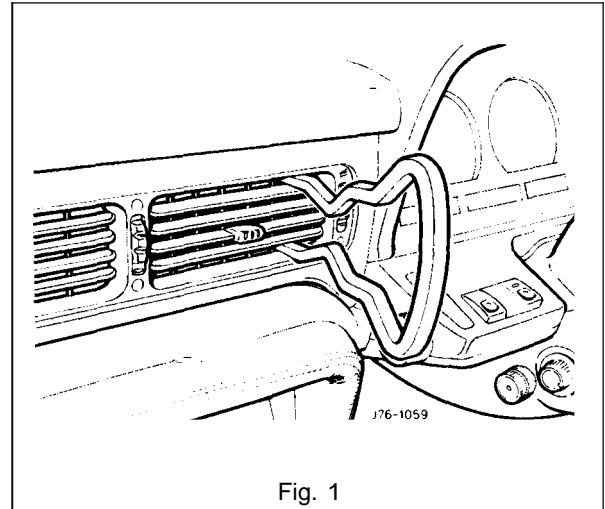



## 13.3.24 Console Finisher Veneer Panel, Renew

### SRO 76.47.26

- Apply the handbrake.
- Turn the ignition ON.
- Press the brake pedal and position the gear selector in 'N'.
- Turn the ignition OFF.
- Remove the console ashtray, see sub-section 13.3.28.
- Carefully displace the mode switch from the gear surround finisher. See Fig. 1.
- Disconnect the mode switch from the harness multi-plug. See Fig. 1.
- Displace and remove the switch surround finisher.
- Displace and remove the gear lever surround finisher.
- Displace and remove the veneer panel rear finisher.
- Undo and remove the veneer panel wing nuts. See Fig. 2.
- Displace and remove the console finisher veneer panel. See Fig. 3.
- Remove the stud plates.
- Place the veneer panel aside.
- Place the new panel to the front.
- Fit and align the stud plates.
- Fit and fully seat the veneer panel to the console.
- Fully seat the rear of the veneer panel.
- Fit and tighten the wing nuts.
- Fit and align the veneer panel rear finisher.
- Fit and fully seat the gear lever surround.
- Fit and fully seat the mode switch surround.
- Connect the mode switch to harness multi-plug.
- Fully seat the mode switch.
- Refit the ashtray.
- Place the gear selector in 'P'.

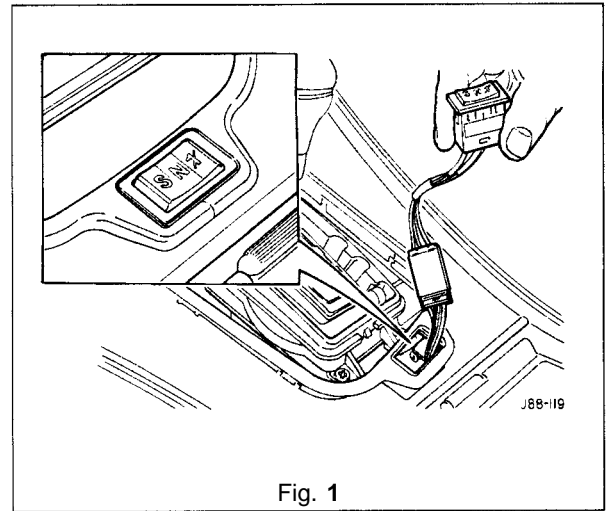

Fig. 1

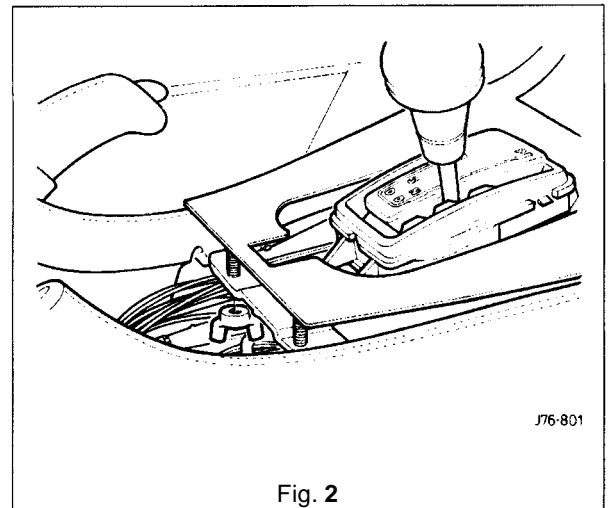

Fig. 2

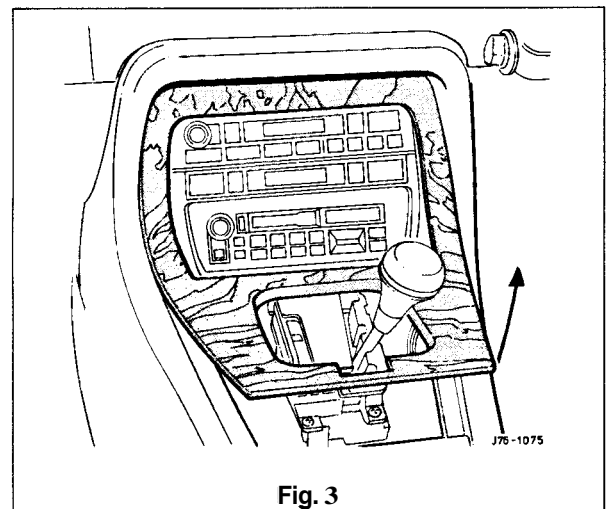

Fig. 3



### 13.3.25 Console Ashtray Lid Veneer Panel, Renew

#### SRO 76.47.27

- Remove the console ashtray, see subsection 13.3.28 and Fig 1.
- Open the ashtray lid.
- Displace and remove the veneer panel securing spire clips.
- Displace and remove the veneer panel.
- Fit and seat the new veneer panel to ashtray lid,
- Fit the veneer panel securing spire clips.
- Close the ashtray.
- Refit the ashtray.

### 13.3.26 Console Ashtray Surround Veneer Panel, Renew

#### SRO 76.47.28

- Remove the console ashtray, see sub-section 13.3.28 and Fig. 1.
- Displace and remove the surround veneer panel securing spire clips.
- Open the ashtray.
- Displace and remove the veneer panel from the ashtray.
- Fit and seat the new veneer panel to the ashtray
- Secure the veneer panel with spire clips.
- Close the ashtray.

### 13.3.27 Console Rear Extension Veneer Panel, Renew

#### SRO 76.47.30

- Remove the console rear extension finisher, see sub-section 13.3.5 and Fig. 2.
- Reposition the front of the veneer panel upwards for access and displace the rear of the panel upwards to release.
- Fit and seat the new veneer panel to the extension and ensure that the rear pegs are fully seated.
- Refit the trim finisher.

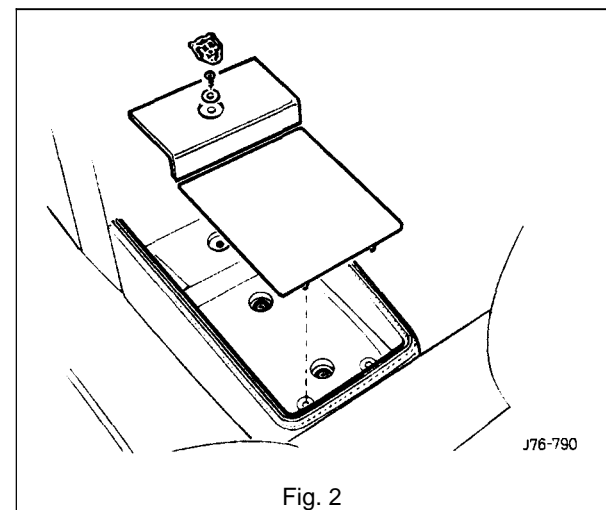
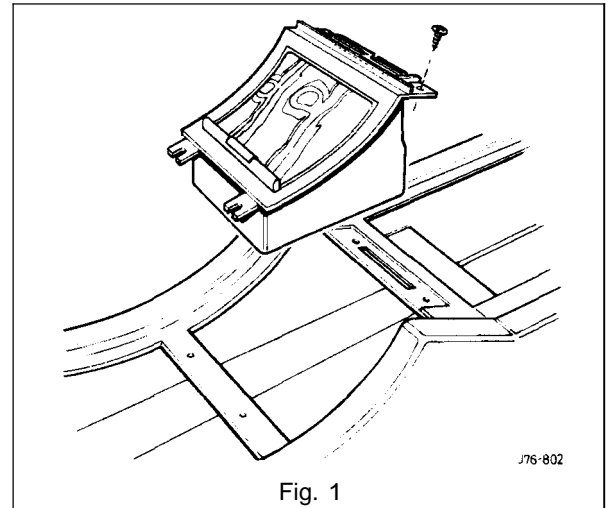



### 13.3.28 Console Ashtray, Renew

SRO 76.67.18

- Raise the trunk lid.
- Remove the battery cover and disconnect the battery.
- Open the glove box lid.
- Undo and remove the ashtray assembly securing screws.
- Displace the ashtray for access.
- Disconnect cigar lighter / illumination Lucar connectors.
- Displace and remove the ashtray assembly.
- Place the ashtray assembly to the front.
- Open the ashtray lid.
- Displace and remove the inner ashtray.
- Displace and remove the cigar lighter element assembly.
- Carefully displace and remove the cigar lighter illumination bulb holder assembly.
- Carefully displace and remove the cigar lighter assembly from the ashtray.
- Carefully remove and discard the ashtray surround veneer panel securing clips.
- Displace and remove the ashtray surround veneer panel.
- Carefully remove and discard the ashtray lid veneer panel securing clips.
- Close the ashtray.
- Displace and remove the ashtray lid veneer panel.
- Displace and remove the inner ashtray retaining clips.
- Place the ashtray aside.
- Place the new ashtray to the front.
- Fit and fully seat the inner ashtray retaining clips.
- Fit and align the lid veneer panel.
- Fit and fully seat the veneer panel securing clips.
- Open the ashtray lid.
- Fit and align the ashtray surround veneer panel.
- Fit and fully seat the veneer panel securing clips.
- Fit and fully seat the cigar lighter assembly.
- Fit and fully seat the illumination bulb assembly, ensuring that the ground tag contacts the cigar lighter body.
- Fit the cigar lighter element assembly.
- Fit the inner ashtray and close the ashtray lid.
- Place the ashtray in position.
- Reconnect the Lucar connectors.
- Reposition and fit the ashtray assembly.
- Fit and tighten the ashtray securing screws.
- Close the glovebox lid.
- Reconnect the battery and refit the battery cover.

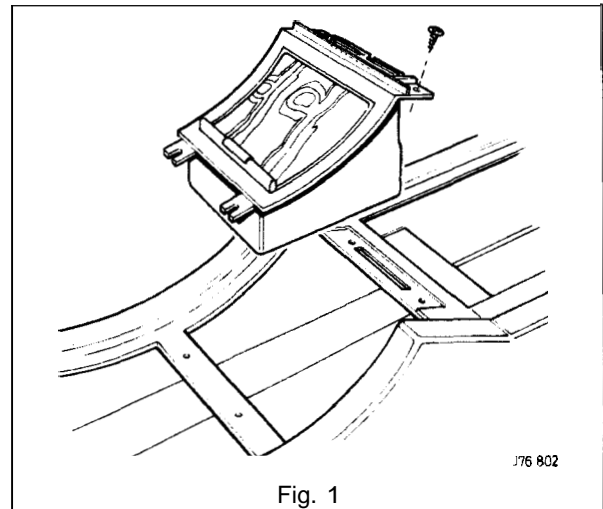

Fig. 1



### 13.3.29 Steering Column Upper Cowl, Renew

#### SRO 76.46.02

- Motor the drivers seat fully rearward.
- Undo and remove the lower cowl fixing screws (1 Fig. 1).
- Displace and reposition the lower cowl (2 Fig. 1); discard the ignition lock rubber gaiter (3 Fig. 1).
- Motor the steering column fully upwards.
- Undo and remove the upper column securing screws.
- Motor the column fully downwards.
- Displace and remove the upper cowl (4 Fig. 1).
- Fit and align the new cowl into position.
- Motor the column fully upwards.
- Fit and tighten the cowl securing screws.
- Fit a new ignition lock rubber gaiter and position the lower cowl to the steering column.
- Fit and tighten the cowl securing screws.
- Motor the column to the original position.

### 13.3.30 Steering Column Lower Cowl, Renew

#### SRO 76.46.03

- Motor the drivers seat fully rearwards.
- Undo and remove the lower column cowl securing screws (1 Fig. 1).
- Displace and reposition the lower cowl (2 Fig. 1).
- Disconnect the rheostat multi-plug (5 Fig. 1).
- Disconnect the tilt column harness multi-plug from the tilt column switch (6 Fig. 1).
- Remove the cowl and place to the front; remove the ignition lock rubber gaiter and discard (3 Fig. 1).
- Displace and remove the rheostat adjusting knob (7 Fig. 1).
- Undo and remove the rheostat securing screws (8 Fig. 1).
- Displace the tilt column switch retaining tangs and remove the switch.
- Place the cowl aside.
- Place the new lower cowl to the front.
- Fit and fully seat the column switch.
- Fit and align the rheostat. Fit and tighten the rheostat securing screws.
- Fit and fully seat the rheostat knob.
- Fit new ignition switch rubber gaiter and reposition the lower cowl.
- Connect the rheostat harness multi-plug.
- Connect the column switch harness multi-plug.
- Position the cowl to the steering column.
- Fit and tighten the cowl securing screws.
- Motor the seat to the original position.

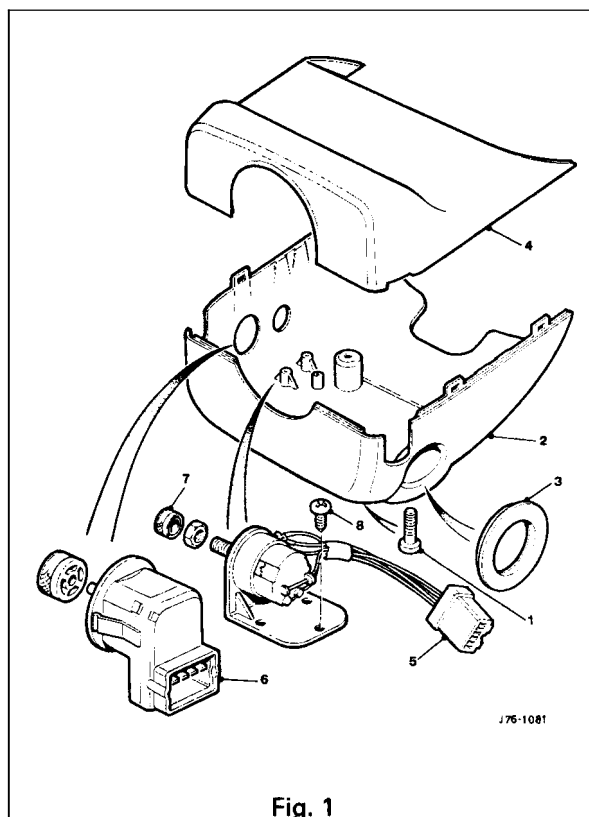
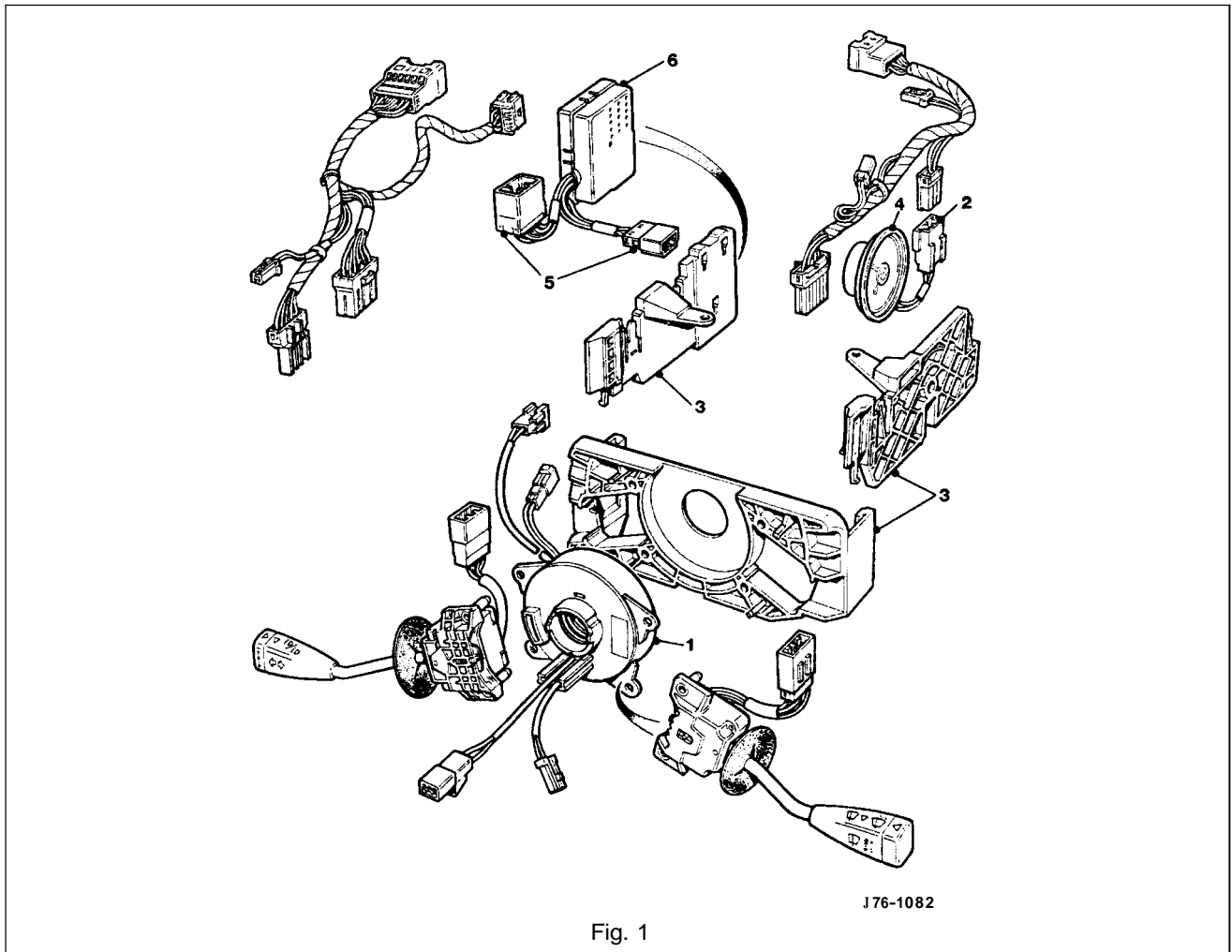

Fig. 1



## 13.3.31 Steering Column Switchgear Mounting Bracket, Renew

SRO 76.46.33



- Remove the steering column lower and upper cowls, see subsections 13.3.30 and 13.3.29.
- Remove the battery cover and disconnect the battery.
- Remove the driver airbag module, see section 15.1.
- Remove the steering wheel, see section 10.
- Remove the cassette and cancellation module (1 Fig. 1), see section 10.
- Displace the audible warning speaker multi-plug (2 Fig. 1) from the mounting bracket (3 Fig. 1).
- Disconnect the speaker multi-plug.
- Displace and remove the switch gear mounting bracket (3 Fig. 1).
- Undo and remove the audible warning speaker securing screws.
- Undo and remove speaker/ harness securing 'P' clip nut.
- Displace the 'P' clip nut.
- Remove the audible warning speaker (4 Fig. 1).
- Displace the dimmer module multi-plug (5 Fig. 1) from the mounting bracket.



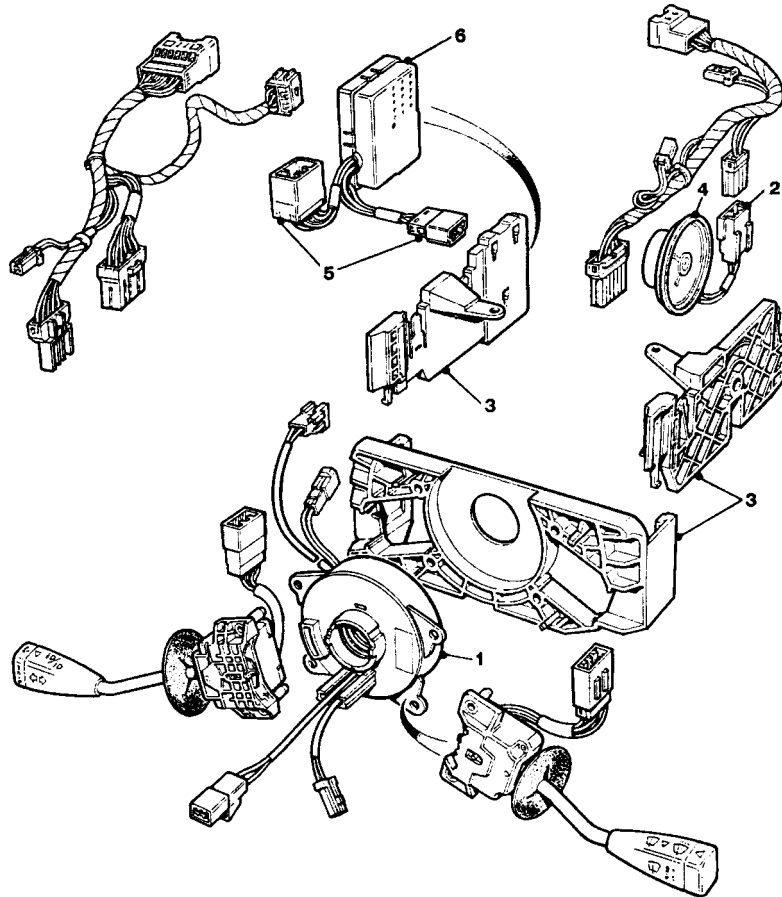

J76-1082

Fig. 1

- Displace and remove the dimmer module (6 Fig. 1).
- Discard the foam pads from the mounting bracket.
- Place the mounting bracket aside.
- Place new mounting bracket to the front.
- Place new foam pads to the front.
- Remove the foam backing paper.
- Fit and fully seat the pads to the mounting bracket.
- Fit and align the audible warning speaker to the mounting bracket.
- Fit and tighten the speaker securing screws.
- Fit and align the speaker harness 'P' clip.
- Fit and tighten the clip securing nut.
- Fit and align the switchgear mounting bracket.
- Connect the speaker harness multi-plug.
- Position the harness to the mounting bracket.
- Refit the cassette and cancellation module.
- Refit the steering wheel.
- Refit the driver airbag.
- Reconnect the battery and refit the battery cover.
- Close the trunk.
- Refit the steering column upper and lower cowl.



### 13.3.32 'A' Post Lower Trim Pad, Renew

#### SRO 76.13.30

- Locally displace the draught welting from the front door aperture flange.
- Undo and remove the 'A' post lower trim pad quarter turn fastener.
- Displace and remove the 'A' post lower trim pad by pulling rearwards to disengage clips and place aside.
- Fit and seat the new 'A' post lower trim pad, engaging the clips on the front door flange.
- Fit and secure the 'A' post lower trim pad quarter turn fastener.
- Reposition and fully seat the draught welting to the front door aperture flange.

### 13.3.33 Rear Quarter Upper Trim Pad, Renew

- Remove the rear seat belt upper anchorage RH or LH.
- Remove the trim pad securing screw.
- Slacken but do not remove the combined grab handle and coat hook securing screws.
- Unclip the rear quarter trim pad and remove.
- To refit, carry out reversal of the above procedure, noting that seat belt fixings must be tightened to the specified torque.

### 13.3.34 'B' Post Upper Trim Pad, Renew

- Position front seat and squab fully forward.
- Remove seat belt lower anchorage and feed the belt through the lower trim aperture.
- Remove seat belt upper anchorage.
- Remove trim finisher upper seat belt aperture and door aperture edge trim.
- Release upper trim pad from its fixings by exerting downward pressure.
- To refit, carry out reversal of the above procedure.

**WARNING: ENSURE THAT THE SEAT BELT IS CORRECTLY ASSEMBLED AND FIXINGS TORQUE TIGHTENED.**

### 13.3.35 'B' Post Lower Trim Pad, Renew

- Position front seat and squab fully forward.
- Remove seat belt lower anchorage and feed the belt through the lower trim aperture.
- Release trim pad quarter turn fasteners and remove trim pad.
- Remove fasteners from trim pad as required.
- To refit, carry out reversal of the above procedure.

**WARNING: ENSURE THAT THE SEAT BELT IS CORRECTLY ASSEMBLED AND FIXINGS TORQUE TIGHTENED.**



### **13.3.36 Handbrake Lever Trim, Renew**

- Release the trim assembly upper clip and remove trim from handbrake lever.
- To refit, carry out reversal of the above procedure.

### **13.3.37 Combined Grab Handle and Coat Hanger Hook, Renew**

- Carefully prise out and remove screw cover.
- Remove screws and handle / coat hook.
- To refit, carry out reversal of the above procedure.

### **13.3.38 Sun Visor Assembly RH or LH, Renew**

- Disconnect vehicle battery ground lead.
- Lower the sunvisor.
- Remove the screws securing the sunvisor retaining block and support the sunvisor.
- Disconnect the multi-plug situated behind the headlining and remove the sunvisor assembly.
- To refit, carry out reversal of the above procedure.



### 13.3.39 Roof lining (Headlining), Description

The roof lining is a one piece construction of 6mm thick polyurethane foam, covered with brush finish, suede effect, knitted polyester.

### 13.3.40 Roof Lining, Renew

- Position front seats fully rearwards and recline the passenger seat squab.
- Disconnect vehicle battery ground lead.
- Remove:
  - Sliding roof flange (where fitted).
  - Front passenger door.
  - Rear console (where fitted).
  - Center console.
  - Sunblind and bezel.
  - Combined grab handle and coat hook.
  - Rear quarter upper trim pad LH & RH.
  - Cantrail crash roll.
  - Illuminated sun visor.
  - Roof console.
- Release multi-plug connectors from clips at roof console aperture.
- Remove roof console retaining clip from headlining.
- Remove security sensors (where fitted) and disconnect multi-plugs.
- Release roof lining to body tags and lower roof lining.
- Remove the roof lining:
  - Position the roof lining with the rear corner through the passenger side rear door and the opposite corner through the driver side rear door.
  - Position the roof lining across the car with the roof console cut-out straddling 'B'-'C' post.
  - Tip the roof lining forward against bottom of fascia with rear edge of roof lining diagonally across door aperture.
  - Carefully feed the roof lining out of the passenger side front door, easing the edge cut-outs over the door aperture and any other obstruction.
- To refit, carry out reversal of the above procedure.



## 13.4 TRUNK

### 13.4.1 Trunk, Description

The trunk houses the spare wheel, the battery, an electrical carrier containing electrical fuses, relays and modules and a compact disc auto-changer attached to body bracketry. The trunk is fitted with push-fit, velour finish, liners (1 Fig. 1) to the sides and front inner panel; the trunk floor is covered with carpet attached to a removable floor board (2 Fig. 1) and a battery cover (3 Fig. 1), one covering the spare wheel and wheel changing equipment, the other covering the battery and electrical carrier.

The floor board rests on the spare wheel, the front and rear edges of the floor board locating in blocks on the fuel tank backboard and on the rear of the body. The blocks accommodate the two possible height settings caused by the difference in thickness between the space saver and full sized spare wheels.

A tread plate (4 Fig. 1) is attached to the trunk sill and a liner is fitted to the rear of the trunk below the sill. Interior trim finisher panels are fitted to the rear lamp units accessed from the trunk opening.

The trunk lid (5 Fig. 1) is fitted with a removable moulded liner and two trunk illumination lights; the lid is supported by two gas struts, attached through press-on fittings between the inner wheel arch and trunk hinge (6 Fig. 1). A warning triangle is attached by a bracket to the trunk lid and retained in the open position by a rubber block (Europe inc UK only).

Trunk locking is based on a central latch and striker, operated electrically through the central locking system by an adjacent actuator or by key in a barrel lock located behind the trunk lid badge.

For details on renewal of trunk front and side liners, trunk carpet, trunk seal retainer and battery cover, see relevant Service Repair Operations.

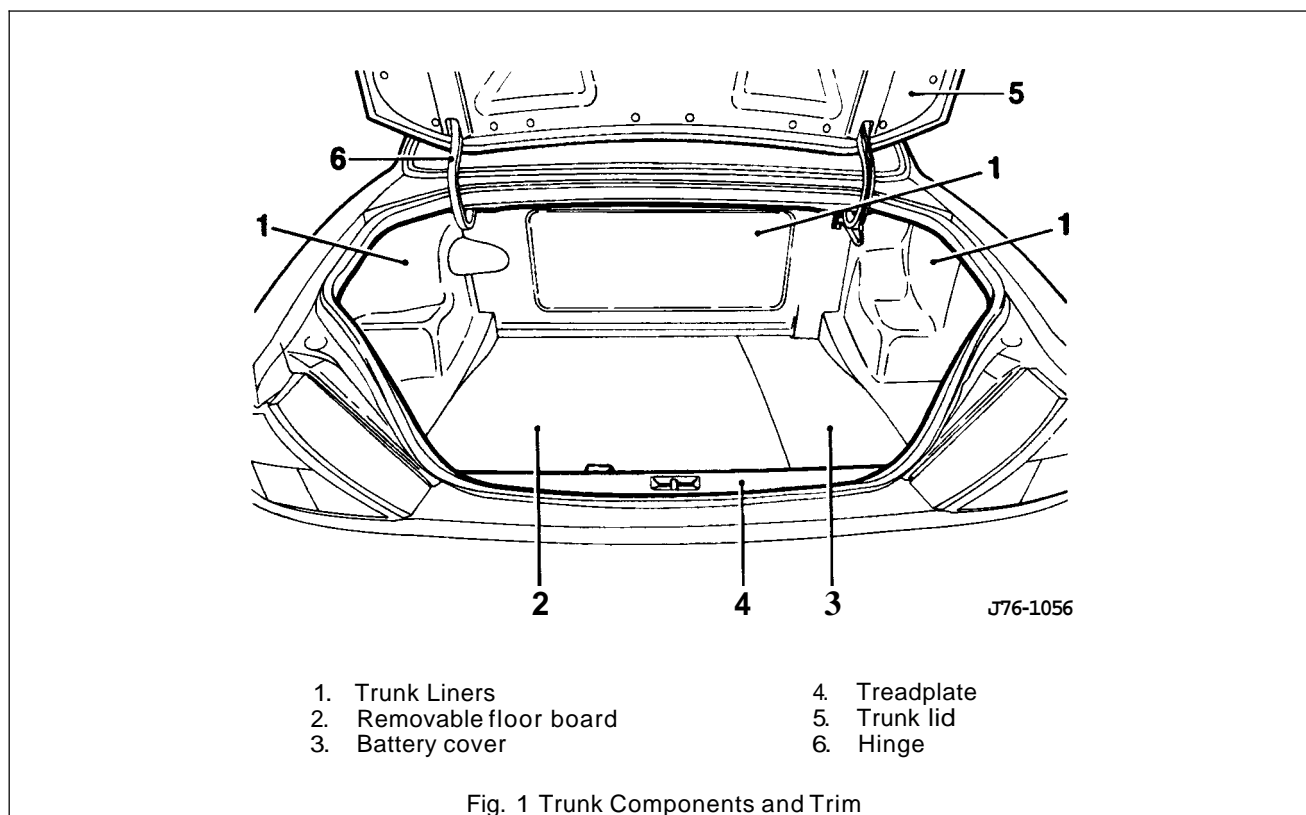



## 13.4.2 Trunk Side Liner – Left Hand, Renew

### SRO 76.19.22

- Raise trunk lid.
- Remove the trunk floor carpet (1 Fig. 1), see subsection 13.4.4.
- Remove the trunk front liner (2 Fig. 1), see subsection 13.4.5.
- Remove the trunk seal retainer (5 Fig. 1), see subsection 13.4.6.
- Displace and remove the trunk side liner (3 Fig. 1), passing the fuel filler manual release cable through the liner.
- Fit and align the new trunk side liner, passing the fuel filler manual release cable through the liner.
- Refit the trunk seal retainer.
- Refit the trunk front liner.
- Refit the trunk floor carpet.

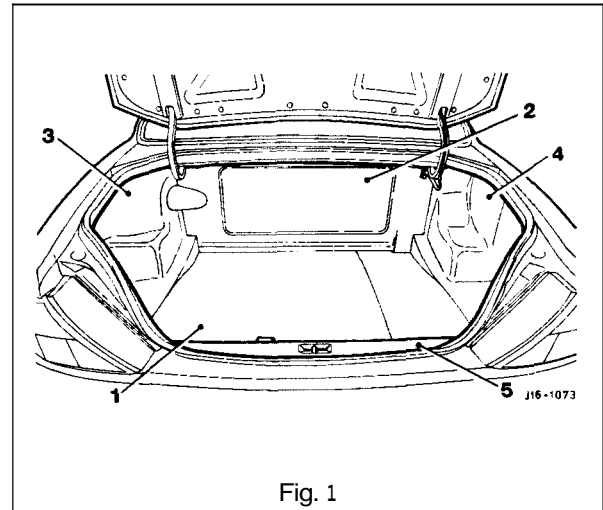

Fig. 1

## 13.4.3 Trunk Side liner – Right Hand, Renew

### SRO 76.19.23

- Raise the trunk lid.
- Remove the trunk floor carpet (1 Fig. 1), see subsection 13.4.4.
- Remove the trunk front liner (2 Fig. 1), see subsection 13.4.5.
- Remove the trunk seal retainer (5 Fig. 1), see subsection 13.4.6.
- Displace and remove the literature pack from the trunk side liner.
- Displace and remove the trunk side liner (4 Fig. 1).
- Fit and align new side liner.
- Fit and align the literature pack to the trunk side liner.
- Refit the trunk seal retainer.
- Refit the trunk front liner.
- Refit the trunk floor carpet.

## 13.4.4 Trunk Floor Carpet, Renew

### SRO 76.19.30

- Displace and remove the trunk floor carpet assembly.
- Fit, align and seat new trunk floor carpet assembly.

## 13.4.5 Trunk Front Liner, Renew

### SRO 76.19.31

- Remove the battery cover.
- Remove the trunk floor carpet, see subsection 13.4.4.
- Displace and remove the trunk floor liner.
- Fit, align and seat new trunk front liner.
- Refit the trunk floor carpet.
- Refit the battery cover.



- Remove the trunk floor carpet, see sub-section 13.4.4.
- Displace and remove the left and right hand tail light covers.
- Undo and remove the trunk seal retainer securing bolts (arrowed on Fig. 1).
- Displace and remove the trunk seal retainer.
- Fit and fully seat the new trunk seal retainer.
- Fit and fully tighten the trunk seal retainer securing bolts.
- Fit and fully seat the tail light covers.
- Refit the trunk floor carpet.

#### **13.4.7 Trunk Lid Striker, Adjust**

- Disconnect vehicle battery ground lead.
- Remove the rear finisher.
- Slacken the striker plate securing bolts and adjust the striker to ensure that the luggage compartment lid aligns

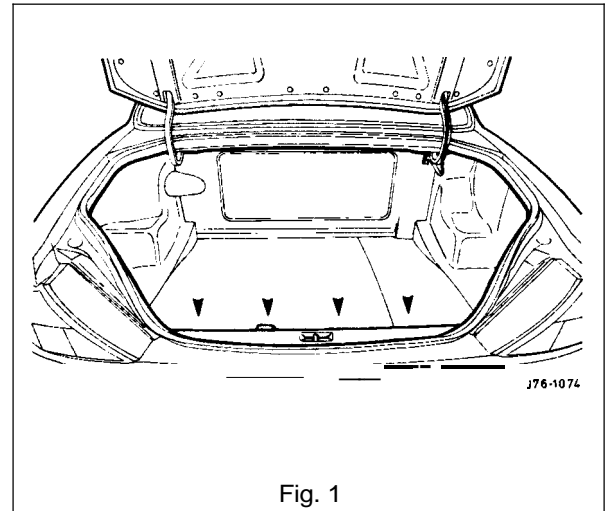



### 13.4.12 Trunk Lid Lock Mechanism, Renew

- Open the trunk and remove the mechanism cover.
- Disconnect the operating rod from the remote linkage.
- Remove the two lock assembly securing bolts, remove the lock from the trunk lid and remove the assembly from the vehicle.
- To refit, carry out reversal of the above procedure.

### 13.4.13 Trunk Lid Gas Strut, Adjust, Renew

- Open the trunk.
- Insert a screwdriver and remove the strut from the top pivot and repeat the operation for the lower pivot.
- Fit the strut to the lower pivot first to aid re-assembly.
- To refit, carry out reversal of the above procedure, changing one strut at a time.

### 13.4.14 Trunk Lid Hinge, Renew

- Open the trunk.
- Remove the hinge cover.
- Cut and remove the harness straps from the RH hinge and move the harness away.

**Note:** Ensure that the lid is adequately supported and that paint damage cannot occur.

- Remove the upper hinge securing bolts.
- Remove the lower hinge fixings.
- To refit, carry out reversal of the above procedure, ensuring that the alignment of the trunk buffers is set relative to the fenders.

### 13.4.15 Trunk Rear Liner, Renew

- Disconnect vehicle battery ground lead.
- Peel back the floor carpet and sound insulation for access.
- Remove the tread plate.
- Remove the trunk rear liner.
- To refit, carry out reversal of the above procedure.





## 13.5 HOOD

### 13.5.1 Hood, Description

The hood is fitted with black moulded covers over the inner fenders and behind the headlamp units; the right hand fender cover incorporates compartments for spare fuses and tool kit (where fitted). Two gas struts attached by press-on fittings on the body and hood support the hood cover.

### 13.5.2 Plenum Chamber Finisher, Renew

#### SRO 76.10.01

- Open the hood and fit suitable fender cover.
- Remove the wiper arm, see section 15.6.
- Undo and remove the plenum chamber finisher securing screws (1 Fig. 1).
- Displace and reposition the plenum chamber.
- Disconnect the washer jet tubes.
- Disconnect the washer jet multi-plugs.
- Displace the washer jet securing tangs.
- Displace and remove the washer jets (2 Fig. 1).
- Place the finisher aside.
- Fit and fully seat the washer jets to the new plenum chamber finisher.
- Connect the washer jet multi-plugs.
- Reconnect the washer jet tubes.
- Position the plenum chamber finisher.
- Fit and tighten the finisher securing screws.
- Refit the wiper arm.
- Remove the fender cover and close the hood.

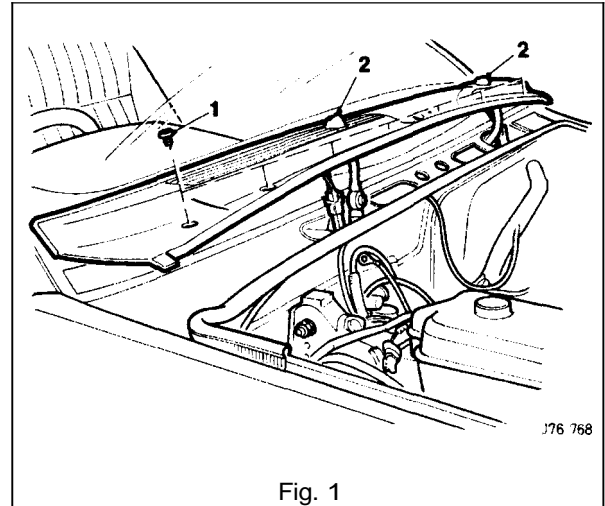

Fig. 1

### 13.5.3 Hinge, Renew

- Disconnect vehicle battery ground lead.
- Open hood and fit fender protectors.
- Remove radiator grille.
- 12 cylinder only:
- Remove fan cowl to top panel clips and move the cowl assembly clear.
- Move water bleed pipe from top panel clips.
- Release fixings and remove radiator top mounting panel.
- Remove hinge securing nuts RH or LH (ground lead on the left hand side).

**CAUTION:** Ensure that the hood cover is adequately supported and that paint damage cannot occur.

- Remove hinge bolts RH or LH, noting the position of the ground lead on the left hand side.
- To refit, carry out reversal of the above procedure, ensuring that the hood should be fully aligned before finally torque tightening the fixings.



### 13.5.4 Gas Strut, Renew

- Disconnect vehicle battery ground lead.
- Open the hood and fit fender protectors.

**CAUTION:** Ensure that the hood cover is adequately supported and that paint damage cannot occur.

- Release upper strut pivot retaining clip and detach the strut from the pivot.
- Repeat for the lower pivot and remove the gas strut.
- To refit, carry out reversal of the above procedure.

### 13.5.5 Hood Lock RH or LH, Renew

- Open the hood and disconnect the lock operating cable from the lock.
- Remove the bolts securing the lock to the body and remove the lock.
- To refit, carry out reversal of the above procedure. Align the lock with the striker prior to tightening.

### 13.5.6 Hood Lock Control Cable RH or LH, Renew

- Slacken the clamp bolt securing the cable to the lock actuator.
- Disconnect the cable from the lock and from the mounting clip.
- Release the cable from the bulkhead mounting clips and remove the tie wraps securing the cable to the pipes and harnesses.
- Remove the cable from the remaining large tie wraps.
- Open the front door.
- Remove the underscuttle pad.
- Pull the release handle and disconnect the cable from the release handle and bracket.
- Pull the cable through the bulkhead grommet and discard.
- To refit, carry out reversal of the above procedure.

### 13.5.7 Hood Striker Assembly, Renew

- Open the hood, slacken the locknut and unscrew the striker.
- Renew any damaged components and reassemble.
- A distance of 62mm from the end of the striker to the locknut may be used as an initial setting.
- Adjust the striker until the hood is flush with the fender.

### 13.5.8 Hood Lock Release Handle, Renew

- With the hood raised: slacken the clamp bolt which secures the cable to the lock actuator. Repeat the procedure for the other side.
- Open the driver side door.
- Remove the underscuttle pad.
- Disconnect the inner cables from the hood release handle.
- Remove the bolts securing the hood release handle to the body, remove the cables from the handle and remove from the vehicle.
- To refit, carry out reversal of the above procedure.



### 13.6 GLAZING (FIXED)

#### 13.6.1 Glazing (Fixed), Description

The fixed glazing comprises internal and external driving mirrors, sunvisor mirror and rear quarter light glass; see Appendix A4, Body Components and Trim for details of the windscreen and rear screen glazing.

#### 13.6.2 Interior Mirror, Renew

- Disconnect vehicle battery ground lead.
- Rotate mirror stem approximately one quarter turn clockwise to release stem from spring contact on windscreen boss.
- Disconnect mirror harness.
- To refit, locate mirror stem base on windscreen boss with stem parallel to top of windscreen, ie one quarter turn displaced from normal position; apply firmly over boss and turn anti-clockwise to lock stem on windscreen boss.
- Reconnect mirror harness.

#### 13.6.3 Sun Visor Mirror Assembly, Renew

- Disconnect vehicle battery ground lead.
- Lower the sunvisor.
- Raise the sunvisor cover and remove the lenses.
- Remove the screws securing the mirror to the sunvisor and remove the mirror.
- To refit, carry out reversal of the above procedure, taking care to correctly locate switch and bulb holders prior to securing the mirror.

#### 13.6.4 Exterior Mirror, Renew

- Disconnect vehicle battery ground lead.
- Remove door trim pad veneer panel and upper trim pad.
- Remove the cheater by sliding off.
- Remove mirror fixings.
- Disconnect the mirror harness block connectors.
- Remove the mirror securing screws and remove the mirror assembly.
- To refit, carry out reversal of the above procedure.

#### 13.6.5 Exterior Mirror Glass, Renew

- Switch ignition on and position the mirror to inboard position.
- Disconnect vehicle battery ground lead.
- Slide assembly outboard and pull outwards.
- To refit, carry out reversal of the above procedure.



### 13.7 CARPETS

#### 13.7.1 Carpets, Description

The passenger compartment carpet is a one piece moulded construction with integrated sound deadening, heel mats and driver's footrest. The carpet is attached to the vehicle floor by plastic clips fitted below the door treadplates. Removal of the carpet requires removal of front seats and the lifting the rear console and removal of the heelboard carpet.

#### 13.7.2 Removal of Stains – General Information

When carrying out any stain removal procedures, observe the following points:

- Immediate action is essential if permanent staining is to be avoided.
- Endeavour to clarify stain, ie water, oil, or combinations and treat accordingly.
- Always work from the edge to the centre of the stain to prevent spreading.
- Do not rub or agitate too vigorously as this action could distort or damage the pile.
- Do not over-wet the carpet.
- Do not over-apply cleaning solvent to foam-backed carpets as this could cause damage to the latex backing compounds.
- When using more than one treatment on the same stain, allow adequate drying time between applications.
- To remove excess moisture, cover the affected area with dry, undyed cloths, white paper towels, etc and weight down; moisture removal is then effected by capillary action.

#### 13.7.3 Powder Cleaning – Removal of Small Spillage Stains

**Note:** Powder cleaners are absorbent particles carrying a solvent / detergent liquor; this type of cleaner is suitable for quick, effective cleaning of all the carpet or of small areas without using chemicals. As the carpet is never more than damp, no drying time is necessary on completion of the cleaning cycle.

To clean carpets using powder cleaners:

- Brush powder onto carpet, allow to dry for 30 minutes and follow the cleaner manufacturers instructions.
- Remove powder and stain by normal vacuum cleaner action.