

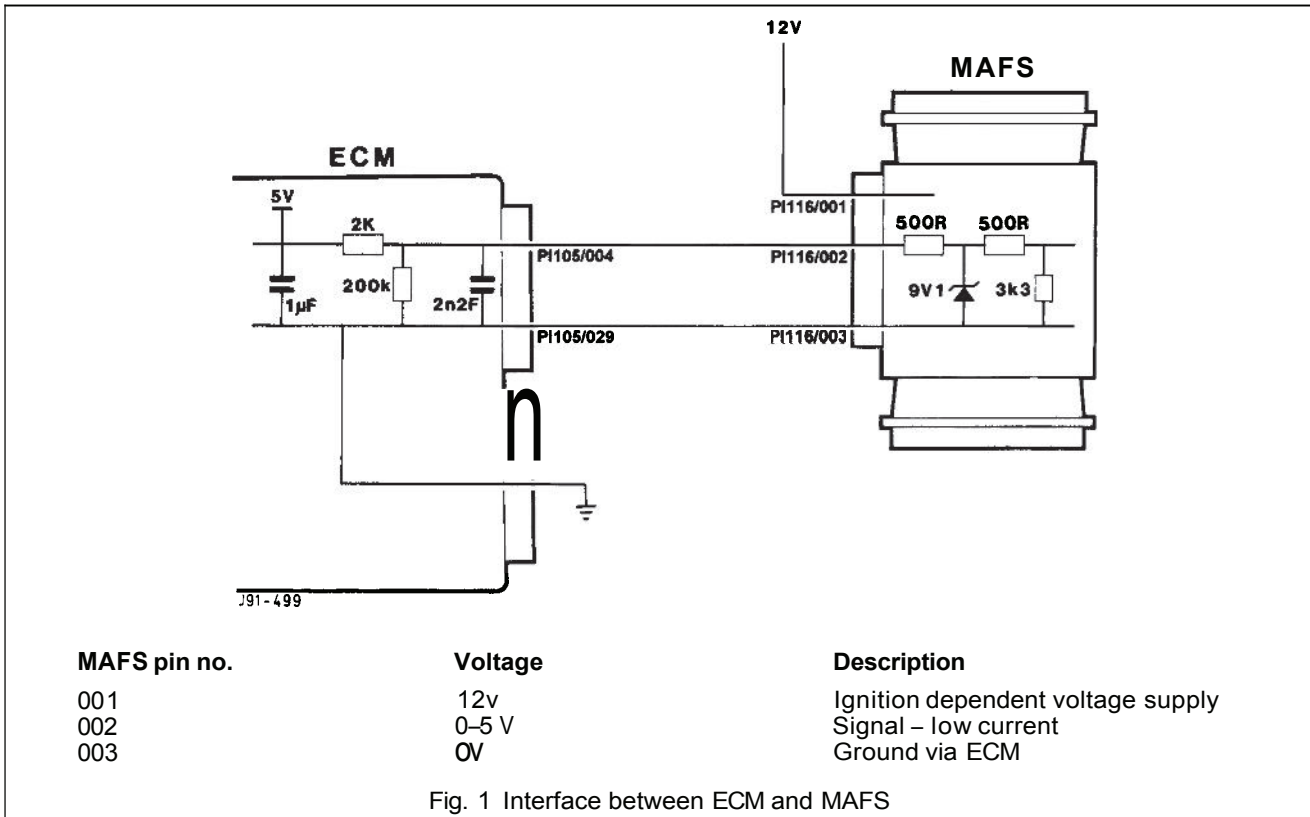

MAFS / ECM Interface Circuit



Additional Information

Nominal Output Voltage (V)	Flow (kg/s)
0.823	0.002
0.977	0.003
1.100	0,004
1.485	0.009
1.897	0.017
2.293	0.030
2.689	0.050
3.108	0.080
3.525	0.120
3.874	0.160
4.279	0.215
4.700	0.284