

1998 XJ RANGE - Engine - 303-01

Secondary Timing Chain Tensioner LH 4.0L, Vehicles Without: Supercharger 12.65.64

Special Service tools

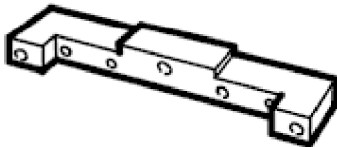

E36401

Camshaft setting
303-530

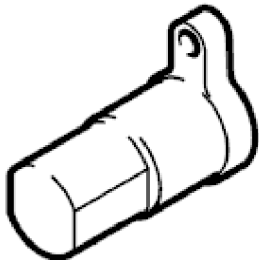

E36408

Crankshaft setting
303-531

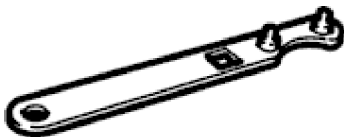

E36402

Timing chain tensioning
303-532

Removal

1998 XJ RANGE - Engine - 303-01

1. Open the engine compartment and fit paintwork protection sheets.

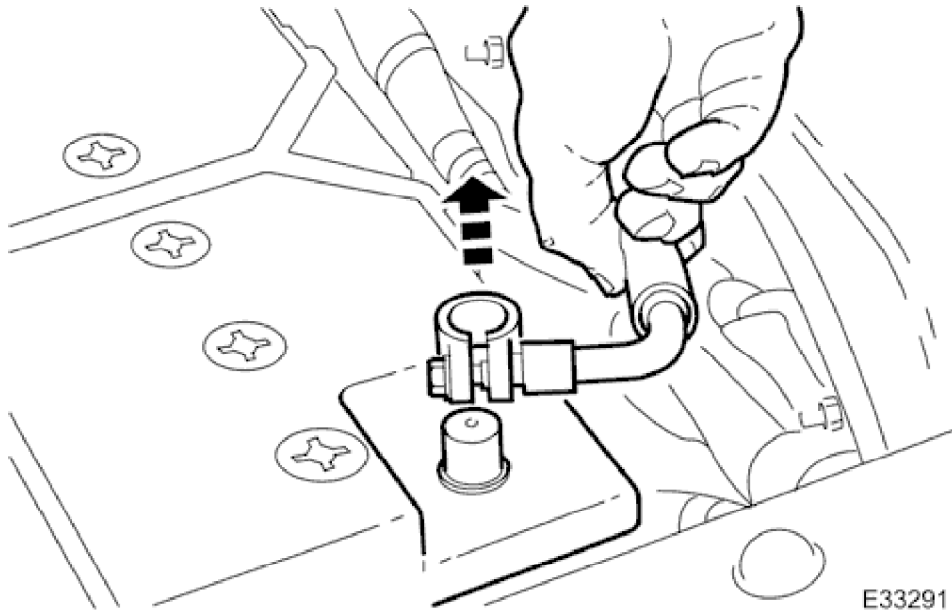

2. Disconnect the battery ground cable.
 - Remove the battery cover.

3. Remove the Cam Cover from Bank 2. Refer to Operation <<12.29.43>>.

4. Raise the vehicle on a ramp.

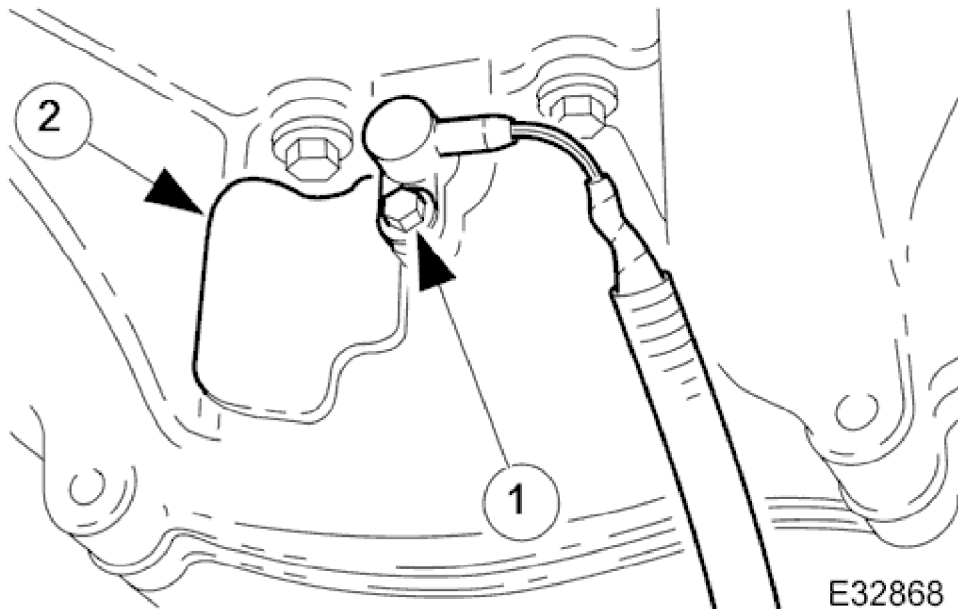

5. Remove the crankshaft position sensor.
 1. Remove the bolt which secures the crankshaft position sensor to the flywheel housing.
 - Remove the sensor and allow it to hang free under the engine.
 2. Remove the access grommet (for torque converter bolts) from the housing.

1998 XJ RANGE - Engine - 303-01

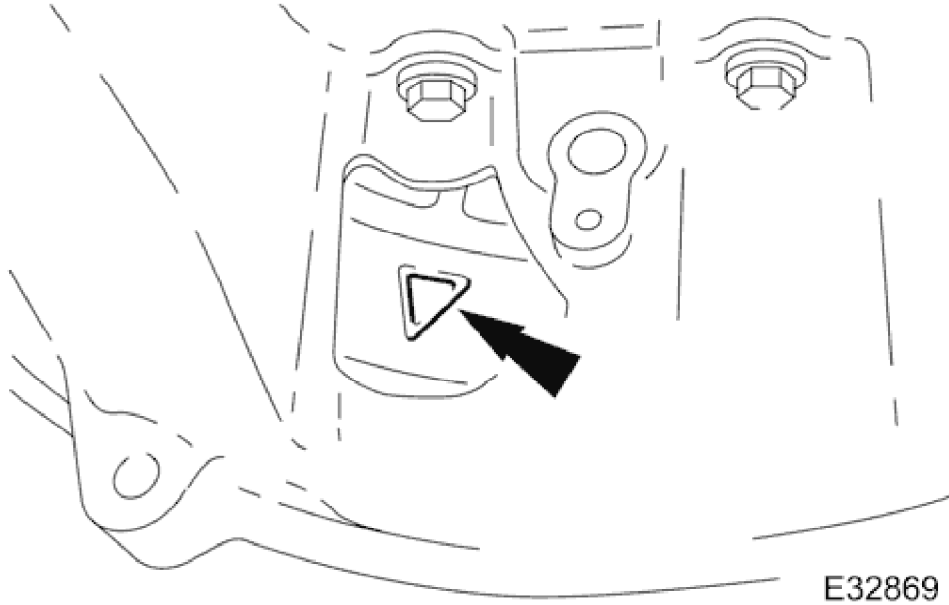

6. Rotate the crankshaft until the triangular arrow indent on the drive plate is visible through the access hole; confirm that the timing flat on each camshaft is uppermost.

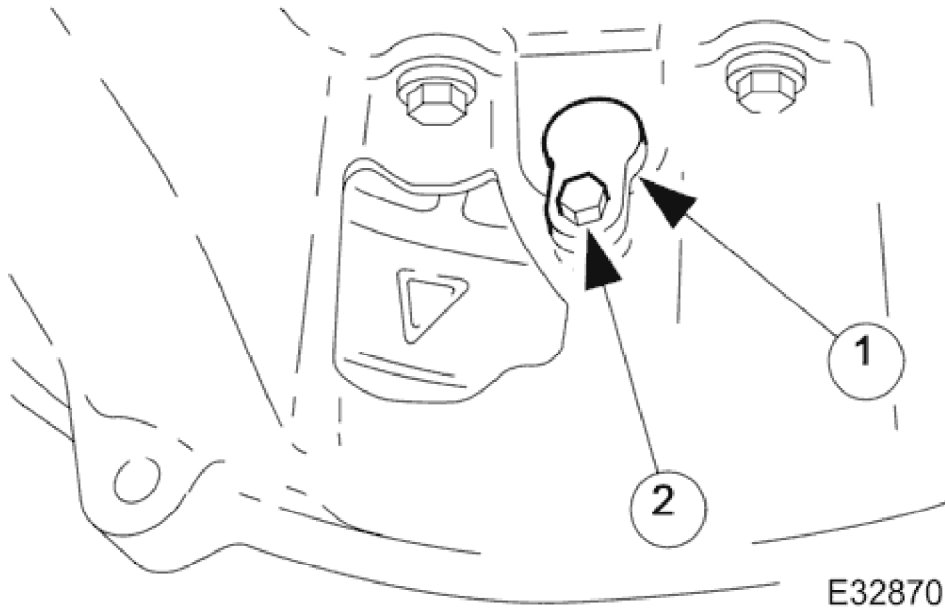

7. Install the crankshaft setting peg 303-531 to the crankshaft position sensor location.

1. Install the crankshaft setting peg 303-531.
 - Position the crankshaft so that the setting peg engages fully into the timing slot.
2. Install and tighten the bolt to secure the setting peg.

8. Lower the vehicle on the ramp.

1998 XJ RANGE - Engine - 303-01

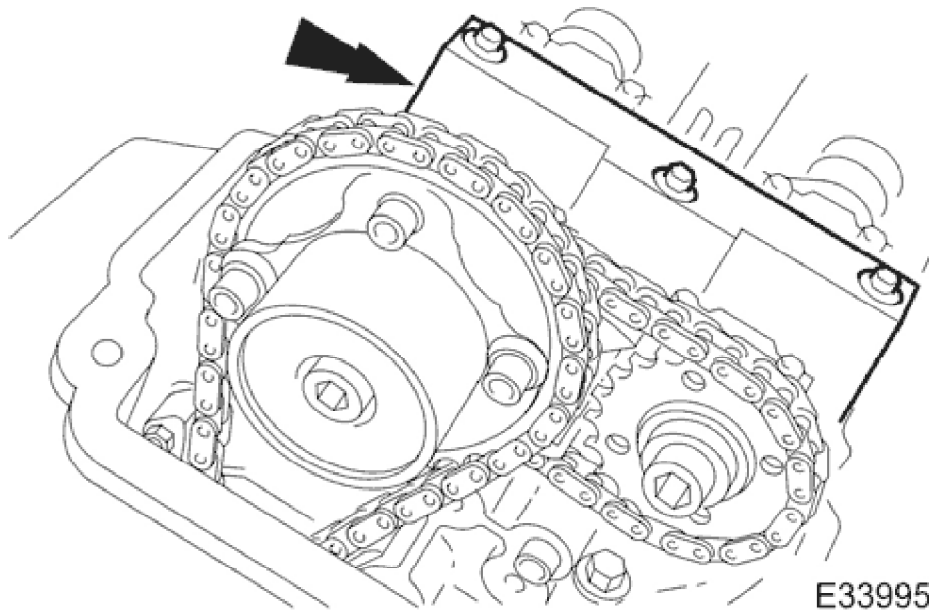

9. Install the camshaft locking tool 303-530 to Bank 2 camshafts, aligning the shafts slightly as necessary.

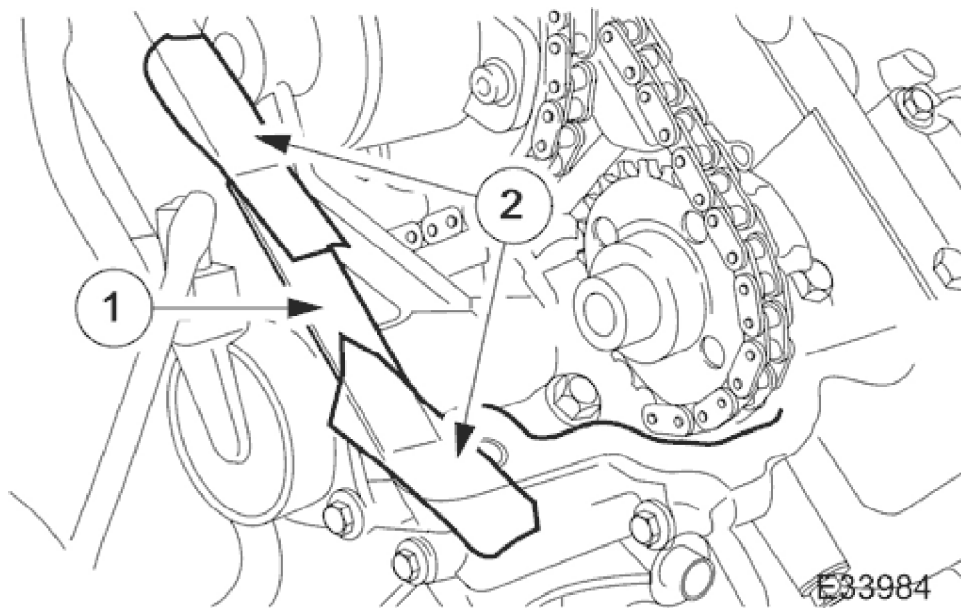

10.  **CAUTION:**
Use a length of steel strip that will not fall into the timing cover.

Protect the upper face of the timing cover from scratches, when removing the bolt which secures the sprocket.

1. Place a flat piece of steel strip along the timing cover horizontal jointing face, adjacent to the exhaust camshaft sprocket.
2. Secure the steel strip in place with adhesive tape.

1998 XJ RANGE - Engine - 303-01

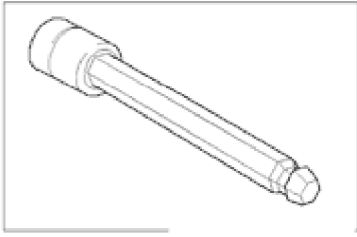

E34593

11. A ball-ended hexagon drive bit is required to remove the sprocket securing bolt. A suitable tool is available from Snap On as (FABLM10E) Long Series 10mm AF.

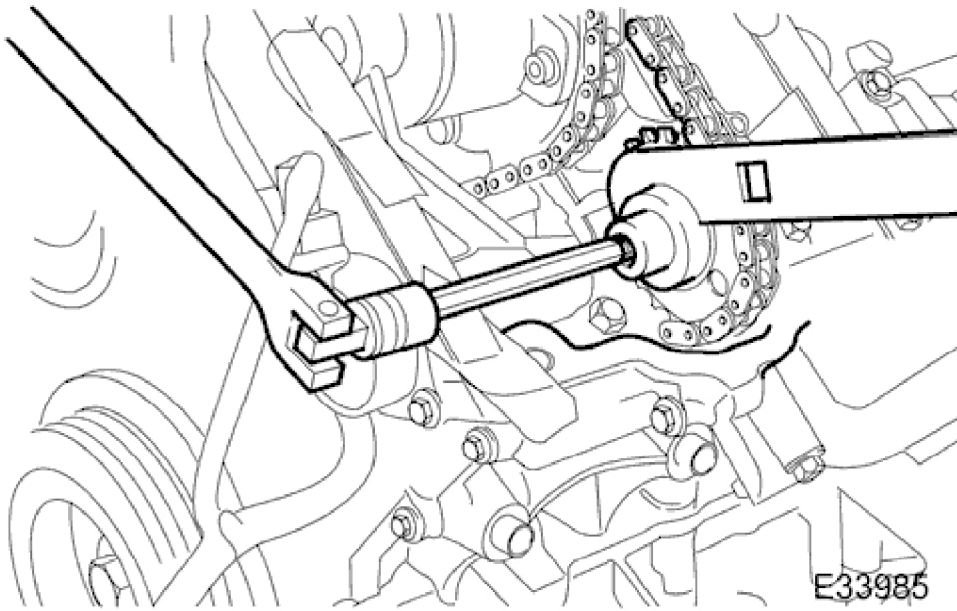

12. Remove the bolt which secures the sprocket to the exhaust camshaft.
- Move the sprocket forward from the camshaft boss.

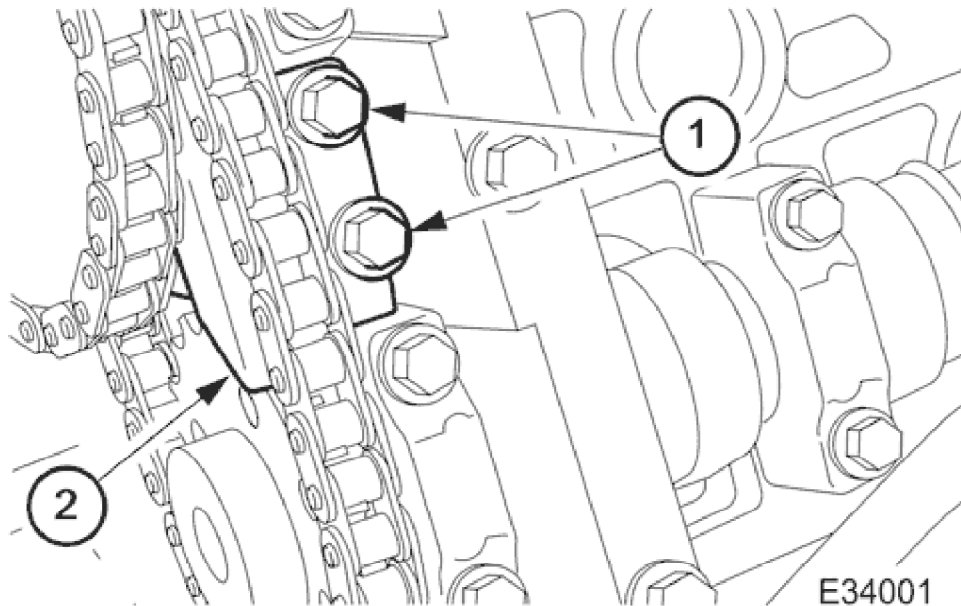

13. Remove the secondary chain tensioner.
- 1. Remove the two bolts which secure the tensioner.
 - Lift the tensioner, sprocket (release it fully from the camshaft) and chain assembly.
 - 2. Remove the tensioner rearward from between the chain.
14. Remove the sprocket if required, or leave it in the chain resting on the cylinder head.
15. Clean and inspect all relevant components.

Installation

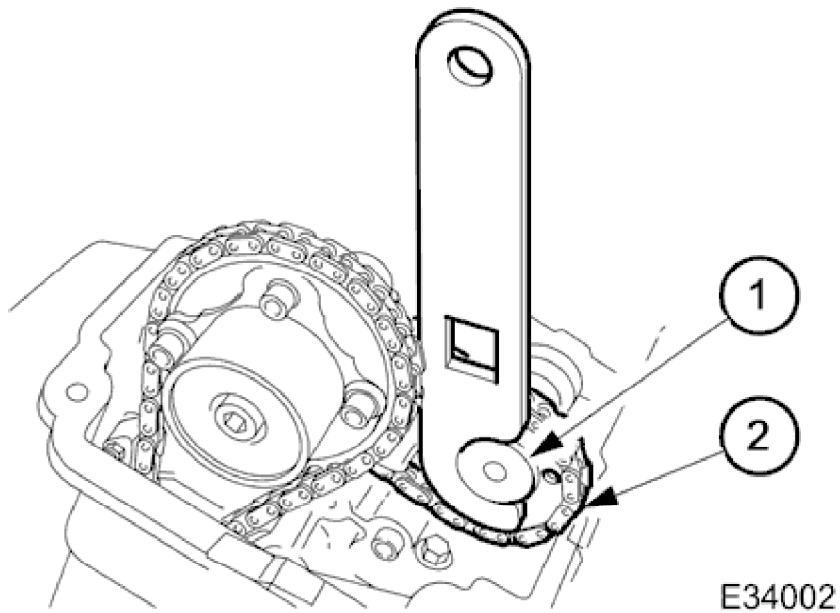

1. Install the sprocket to the secondary chain.

1998 XJ RANGE - Engine - 303-01

1. With the sprocket installed to the chain, temporarily position (do not install the securing bolt) the sprocket onto the camshaft.
 2. Adjust the position of the sprocket within the chain to allow the chain tensoning tool 303-532 to be approximately vertical, as shown.
- Remove the chain tensoning tool; during future operations, do not move the sprocket within the chain.

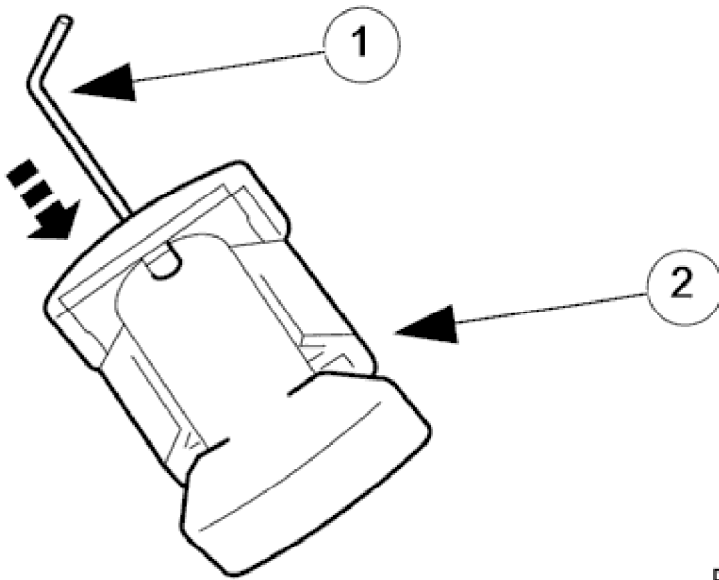

E32920

2. Push the tensoner piston into the body to provide clearance for installing.
 1. Insert a thin rigid wire through the hole in the end of the tensoner piston to displace the ball from the non-return valve seat.
 2. With the wire in position, press the piston fully into the tensoner body.
- Remove the wire.

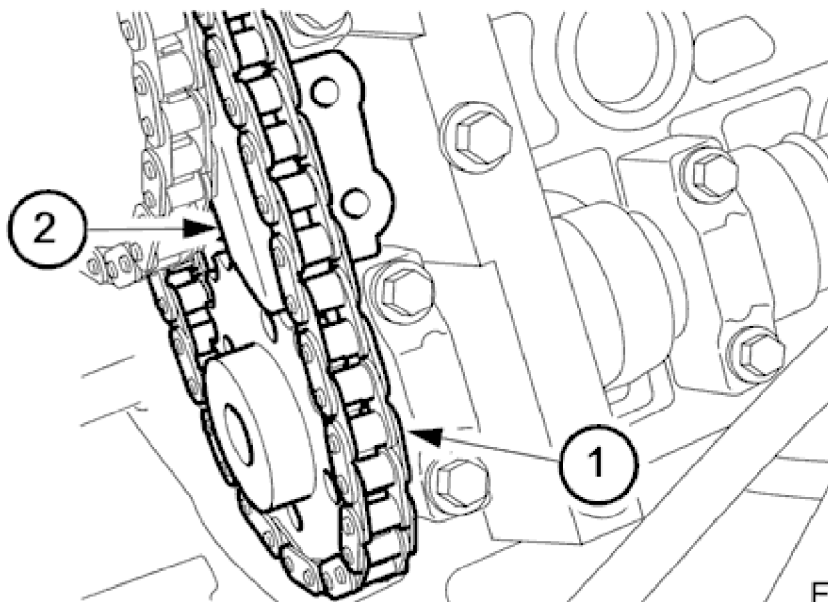

E34003

3. Install the chain tensoner between the chain path.
 1. Reposition the sprocket, still captive in the chain, upwards for access.
 2. Install the chain tensoner between the sprockets.

1998 XJ RANGE - Engine - 303-01

- Position the cam sprocket, chain and tensioner assembly into position and locate the sprocket onto the camshaft spigot.

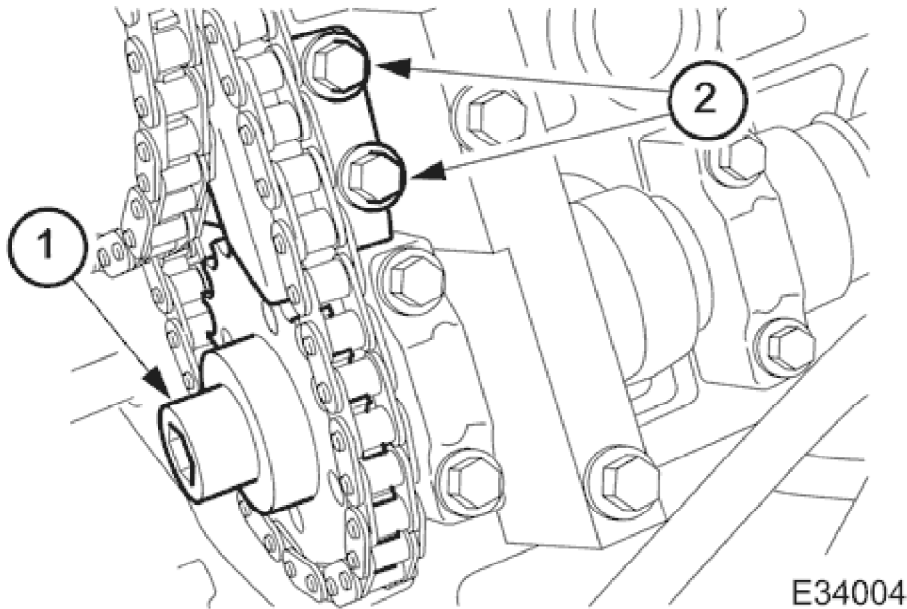

4. Install the chain tensioner to the engine.

1. Fully seat the sprocket onto the camshaft and install the securing bolt, hand tight.
2. Install the two bolts which secure the tensioner and tighten to 10-14 Nm.

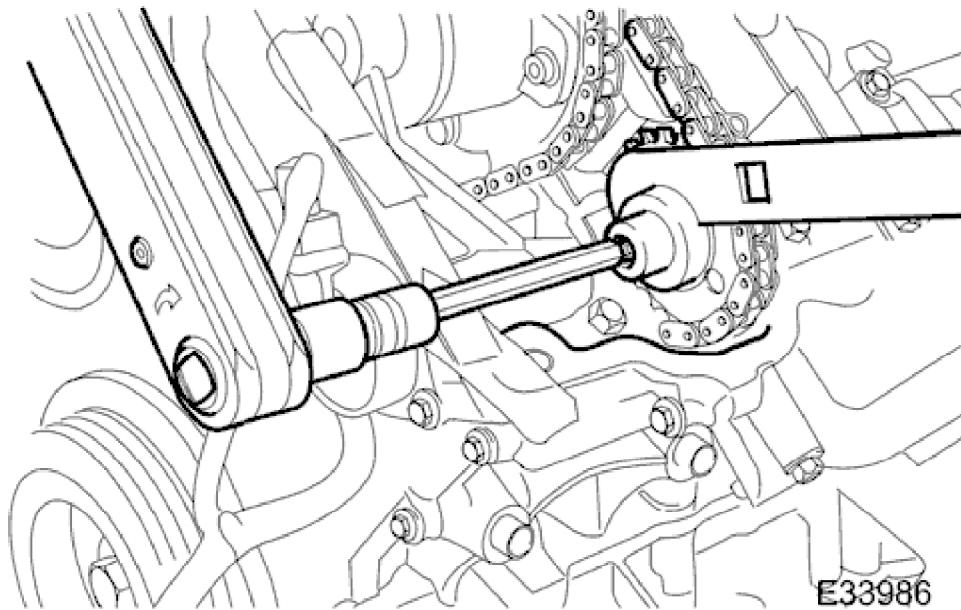

5. Install the camshaft sprocket.

- Install the chain tensioner tool 303-532 to the sprocket holes.
- Apply force to the tool in an anti-clockwise direction to tension the chain on its drive side.
- Whilst applying the opposing force to the sprocket and chain, tighten the sprocket securing bolt to 115-125 Nm.
- Remove the chain tensioning tool.

1998 XJ RANGE - Engine - 303-01

6. Remove the tape and steel strip from the timing cover upper face. Wipe any residue of tape from the joint face.
7. Remove the camshaft locking tool.
8. Install the Cam Cover to Bank 2. Refer to Operation <<12.29.43>>.
9. Raise the vehicle on the ramp.
10. Remove the crankshaft setting tool 303-531.

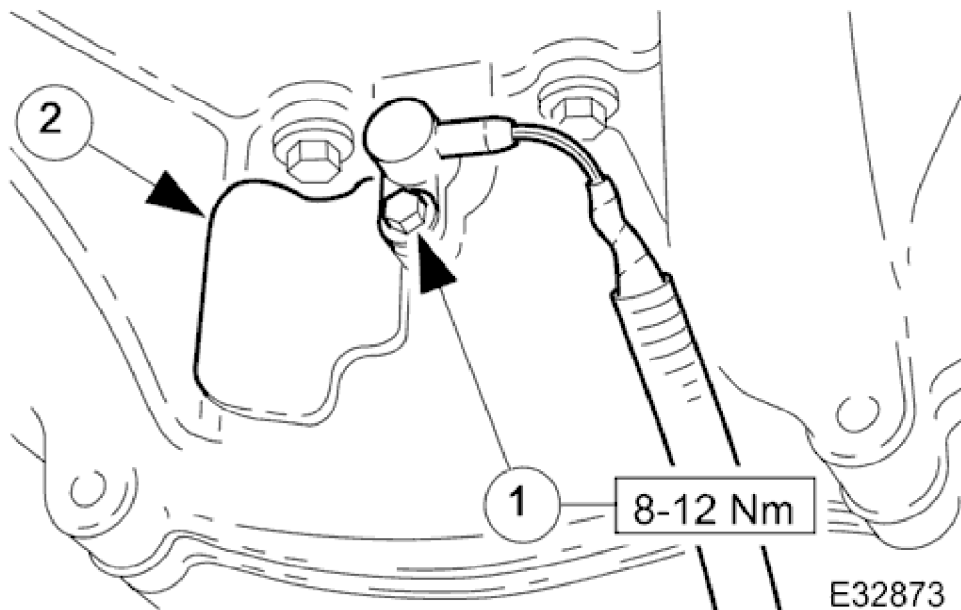

11. Install the crankshaft position sensor.
 1. Install the sensor to the flywheel housing and fit the securing bolt. Tighten to 8-12 Nm.
 2. Install the access grommet to the housing.
12. Lower the ramp.
13. Remove the paint protection sheets and close the engine compartment cover.
14. Connect the battery and install the battery cover.
 - Refer to the Battery Reconnection Procedure <<86.15.15>>.