

Connecting Rod Bearings 12.17.16

Removal

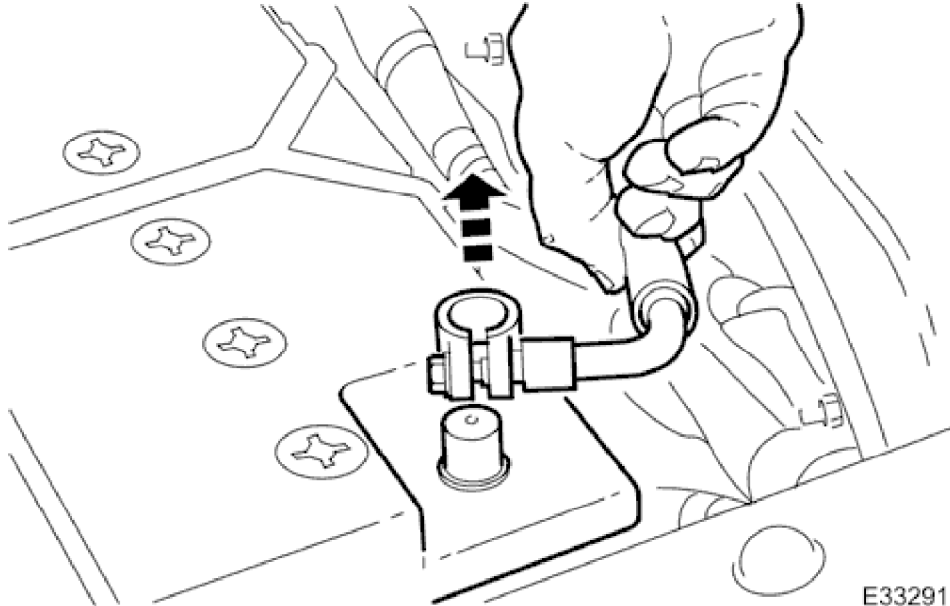

1. Disconnect the battery ground cable.
 - Remove the battery cover.
2. Open the engine compartment and fit paintwork protection sheets.
3. Remove the engine compartment cover. Refer to operation <<76.16.01>>.
4. Remove the twin fan and motor assembly. Refer to Operation 26.25.12.
5. Remove the timing cover and all associated components, as detailed in Operation <<12.65.01>>.
6. Remove both front wheel and tyre assemblies. Refer to Operation <<74.20.05>>.
7. Remove the undertray. Refer to Operation <<76.22.90>>.
8. Remove the front crossmember for access. Refer to Operation 76.10.05.

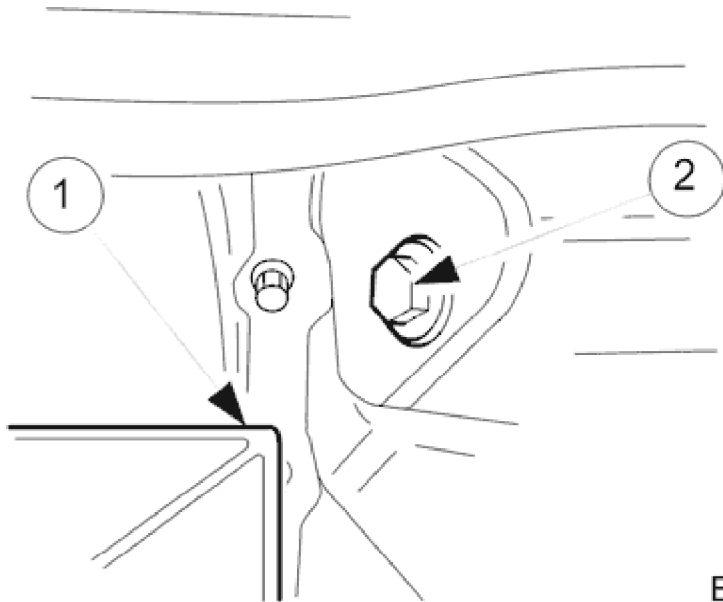

E35325

9. Drain the engine oil.

1. Position the waste oil bowser.
 2. Remove the drain plug from the oil pan and drain the engine oil.
- Install a new sealing washer to the drain plug.
 - Wipe the drain plug and install it to the oil pan to prevent oil dripping.
 - Move the oil bowser away from the vehicle.

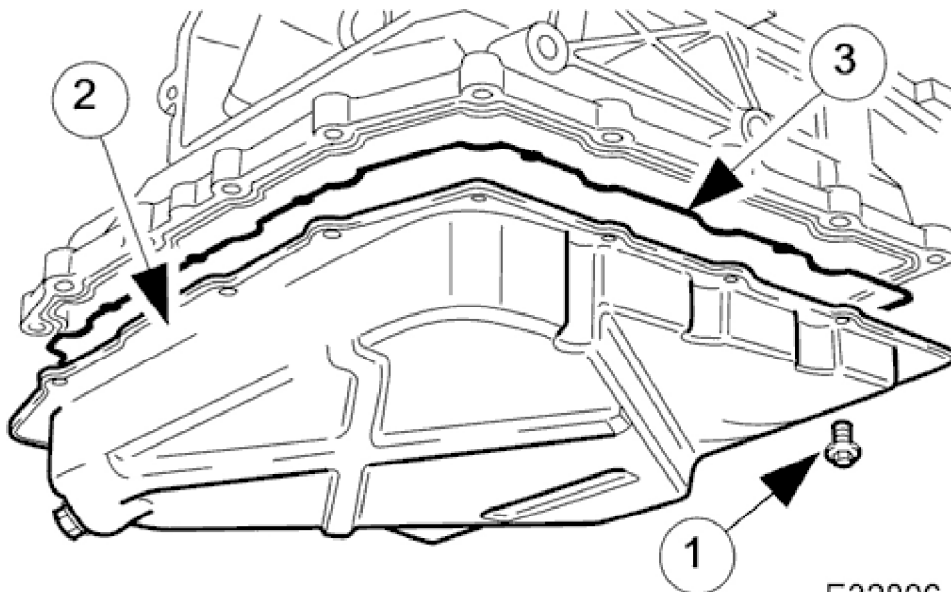

E32806

10. Remove the oil pan.

1. Remove the eighteen bolts which secure the oil pan to the oil pan body.
2. Remove the oil pan.
3. Remove the gasket from the oil pan body assembly.

11. Remove the oil pan body assembly. Refer to Operation <<12.60.48>>.

1998 XJ RANGE - Engine - 303-01

12. Install the old bolt which secured the crankshaft damper, to allow the crankshaft to be rotated. Use a new bolt on final installation.

13. The following group of instructions (until stated otherwise) describe the procedure to renew the bearing shells in one connecting rod. Repeat the instructions as necessary.

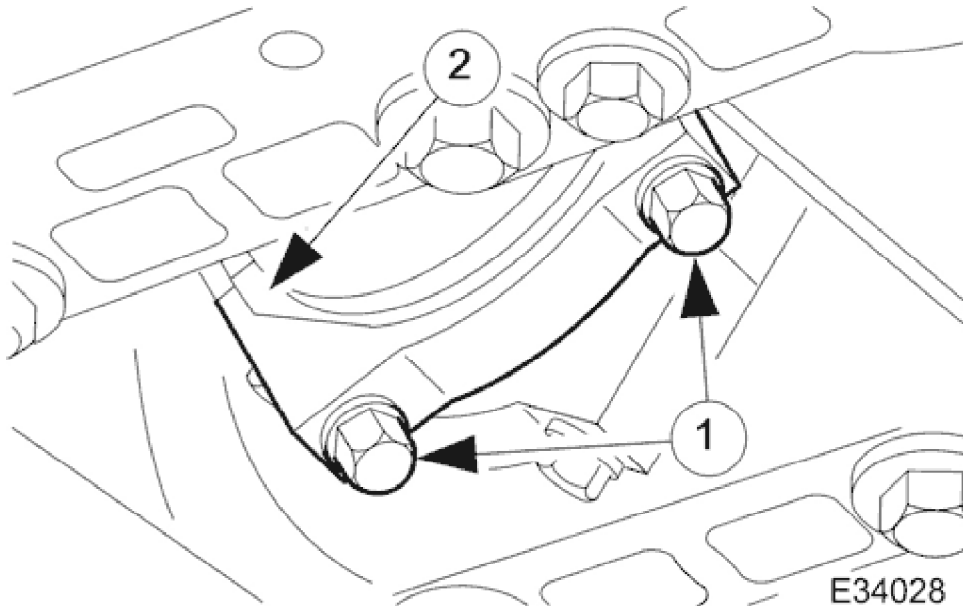

14. Rotate the crankshaft until the required connecting rod bolts are accessible.

1. Remove the bolts which secure the bearing cap.
2. Note the position of the identification marks and remove the cap.
 - Remove the bearing shell from the cap and note the grade (colour coded).

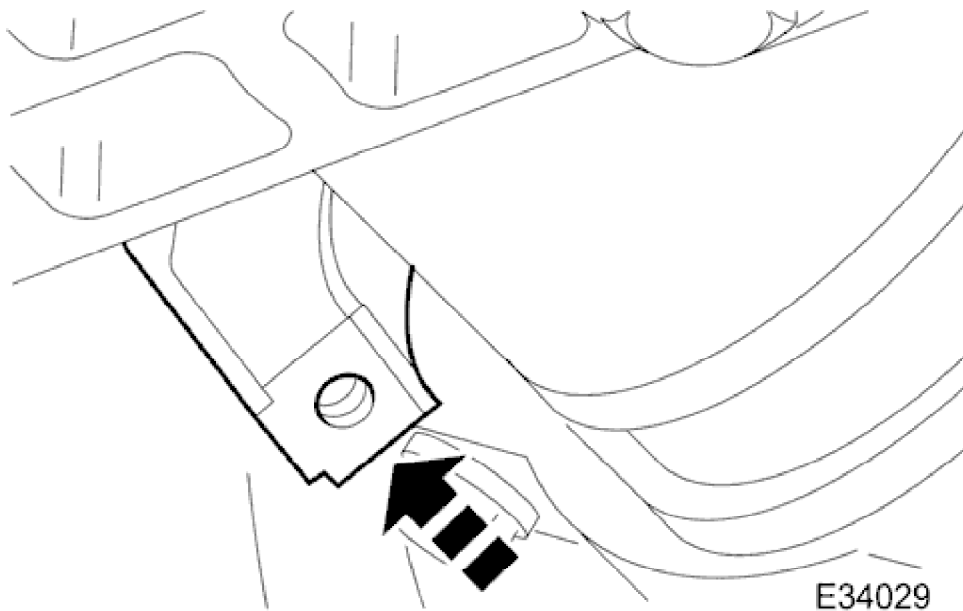

15. Carefully move the connecting rod and piston assembly towards the cylinder head to disconnect it from the crankshaft. Rotate the crankshaft slightly if necessary.

1998 XJ RANGE - Engine - 303-01

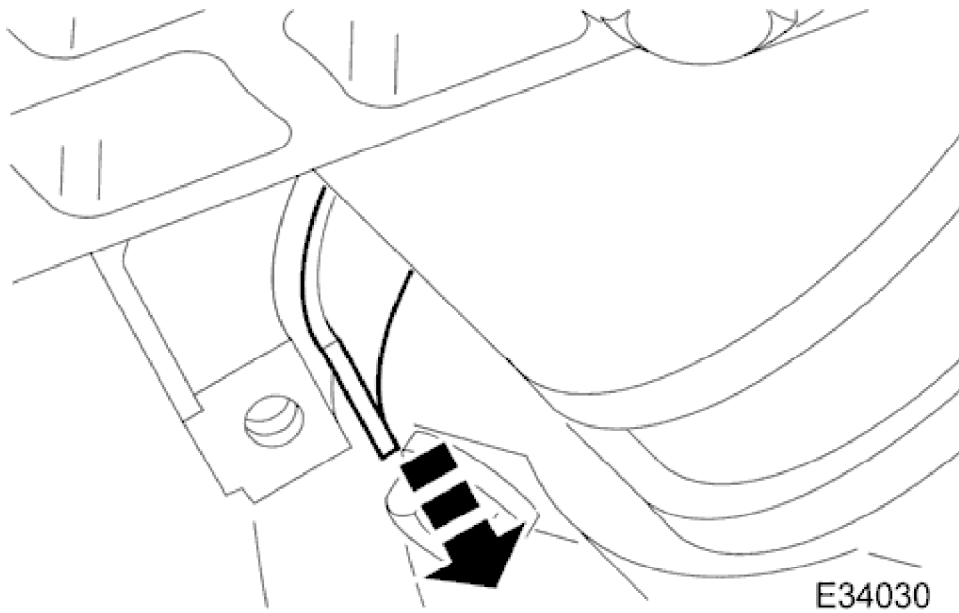

16. Remove the bearing shell from the connecting rod and note the grade (colour coded). The crankpin grades are also stamped on the cylinder block.

17. Refer to the Specification Section for details of the crankpin and bearing shell grades.

18. Clean all components and mating faces.

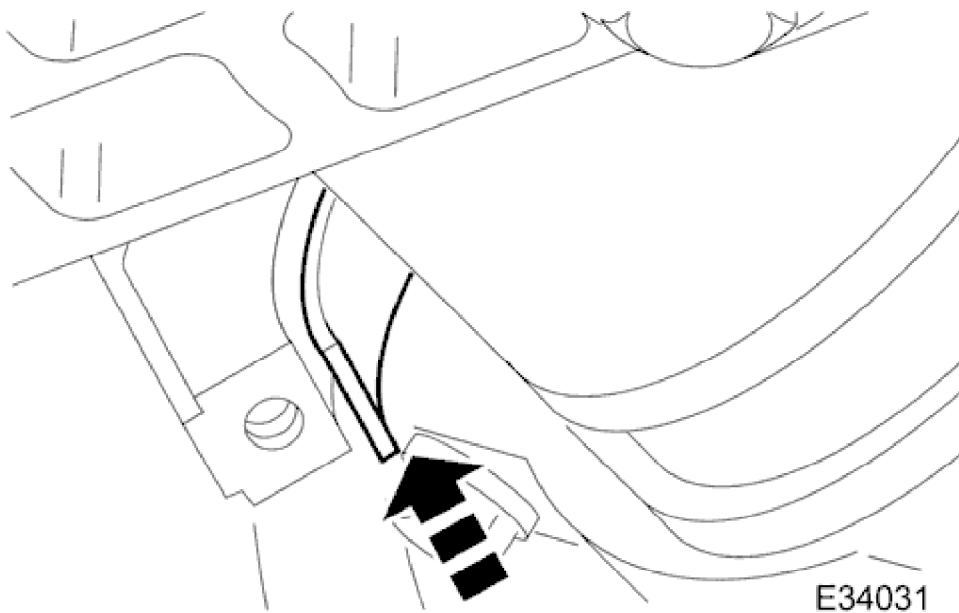

19. Install and align the new bearing shell to the connecting rod.

20. Apply new engine oil to the connecting rod bearing and to the crankpin.

1998 XJ RANGE - Engine - 303-01

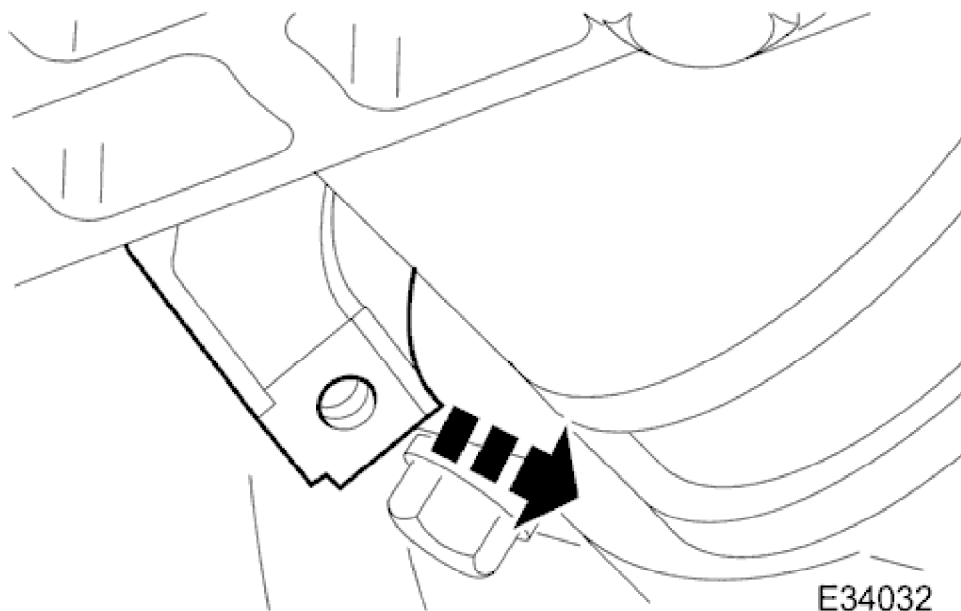

21. Carefully move the connecting rod and piston assembly towards the the crankshaft and connect it to the crankpin. Rotate the crankshaft slightly if necessary.

22. If necessary, refer to the Specification Section for details of piston and connecting rod orientation.

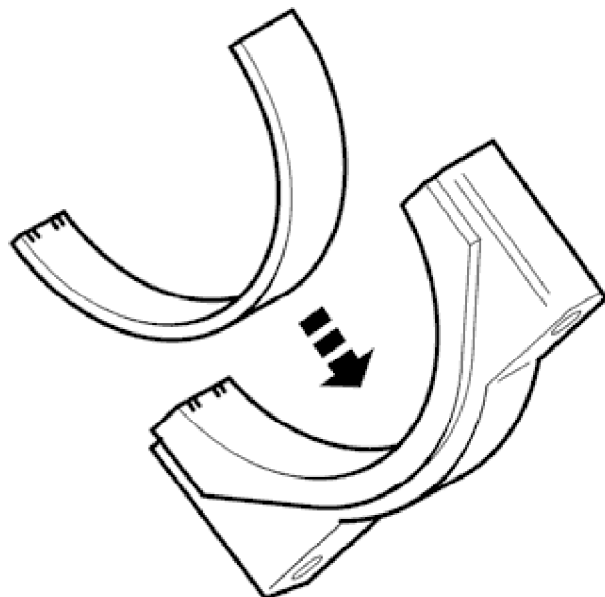

23. Install and align the new bearing shell to the connecting rod cap.

24. Apply new engine oil to the bearing shell.

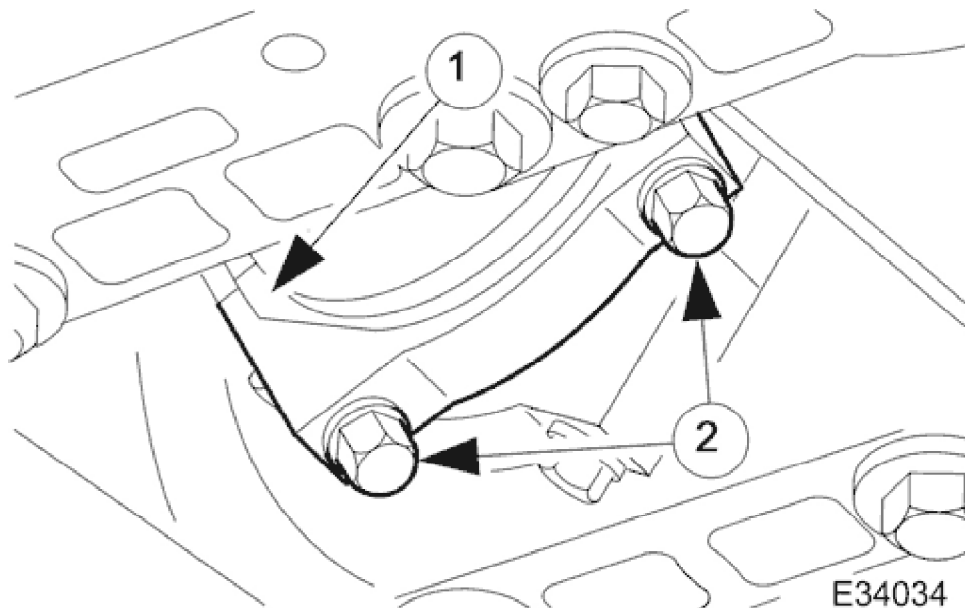

25. Install the cap and NEW bolts to the connecting rod.

1. Note the position of the identification marks and install the cap so that the identification marks are adjacent to those on the connecting rod.
2. Install the new bolts which secure the bearing cap.

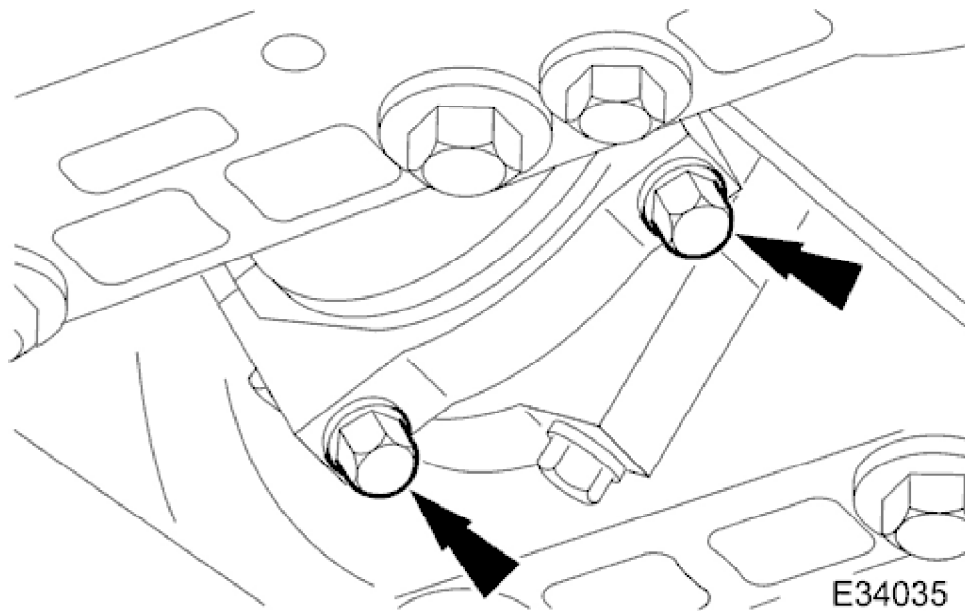

26. Tighten the bolts as follows:

- Tighten each bolt to 8 to 12 Nm initial torque value.
- Tighten to a final torque of 57 to 63 Nm.

27. Check that the crankshaft turns freely.

28. Repeat the previous operations for each connecting rod bearing as necessary.

Installation

1. Install the oil pan body assembly. Refer to Operation <<12.60.48>>.

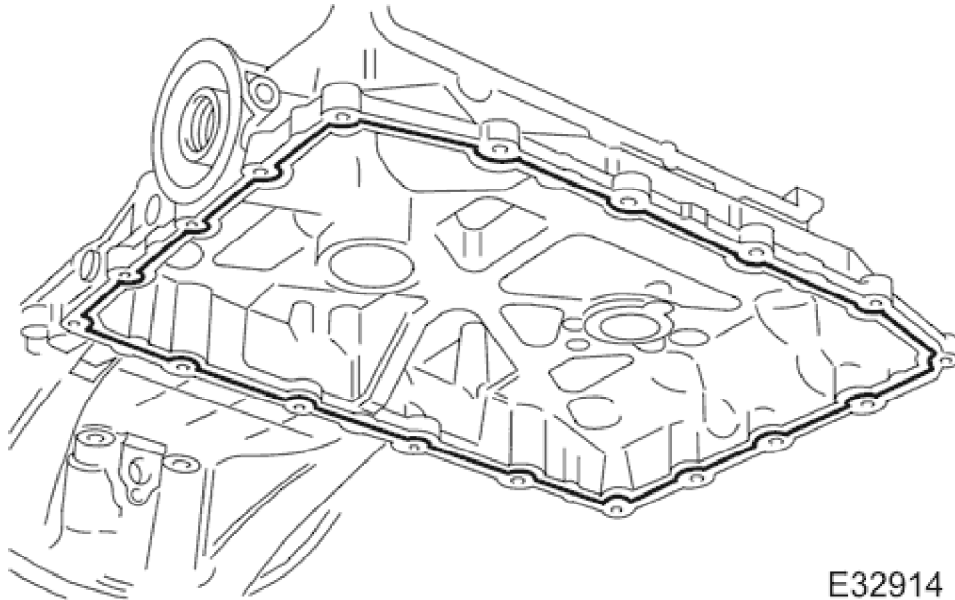

2. Position and align the oil pan gasket to the oil pan body assembly.
 - Insert the seal into the locating positions in the groove, working around from a corner.
 - Press in the remainder of the seal, following the same procedure.

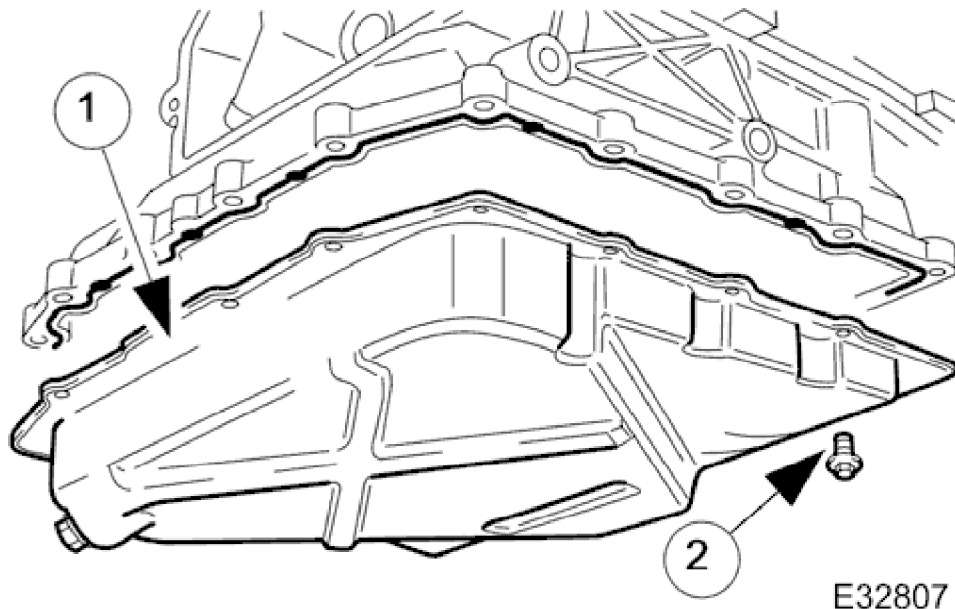

3. Install the oil pan to the oil pan body.
 1. Position and align the oil pan.
 2. Install, but do not tighten, all eighteen bolts which secure the oil pan.

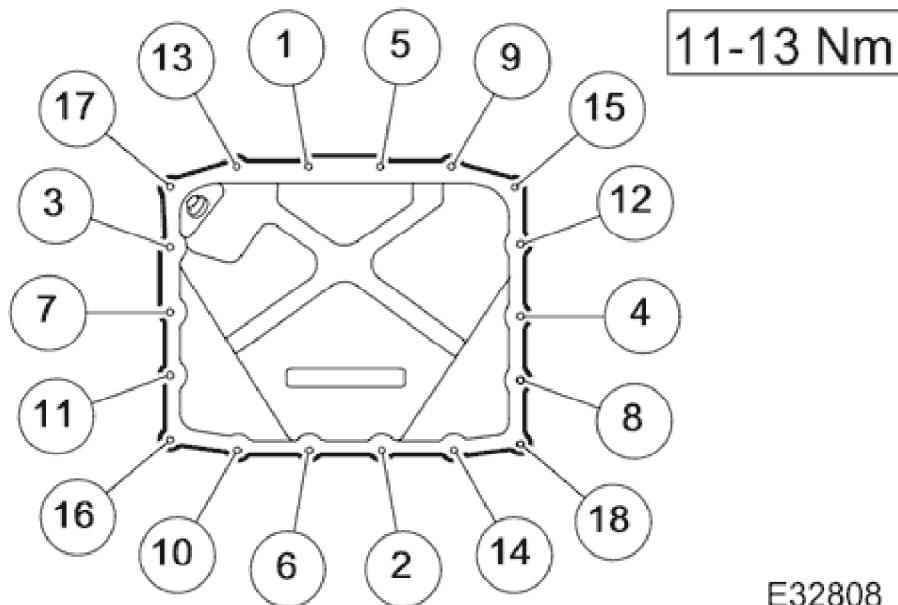

4. Tighten the bolts to the correct torque figure 11-13 Nm, in the sequence indicated.
 - Tighten the drain plug to 30-40 Nm.
 - Install a new oil filter.

5. Install the front crossmember. Refer to Operation 76.10.05.

6. Install the undertray. Refer to Operation <<76.22.90>>.

7. Install both front wheel and tyre assemblies. Refer to Operation <<74.20.05>>.

8. Install the timing cover and all associated components, as detailed in Operation <<12.65.01>>.

9. Install the twin fan and motor assembly. Refer to Operation 26.25.12.

10. **NOTE:**

When the engine is started from cold and run for a short period only, before being switched off, a quantity of oil will be 'hung up' within the engine because it is not up to operating temperature.

Should the oil level subsequently be topped-up, the level could become too high, causing oil burning.

Typically, 0.875 L is hung up.

Refill the engine with the correct specification engine oil.

11. Connect the battery and install the battery cover.

- Refer to the Battery Reconnection Procedure <<86.15.15>>.

12. Check the oil level and start the engine. Check for leaks and that the engine runs correctly.

1998 XJ RANGE - Engine - 303-01

13. Install the engine compartment cover. Refer to operation <<**76.16.01**>>.
14. Remove the paintwork protection sheets and close the engine compartment cover.