

Engine Cooling - Cooling System Draining, Filling and Bleeding 4.0L SC V8 - AJ26

General Procedures

Drain

1. Open the engine compartment and fit paintwork protection sheets.
2. Ensure that the cooling system is cool and very carefully, remove the pressure cap from the header tank.
3. Raise the vehicle.
4. Drain the coolant.

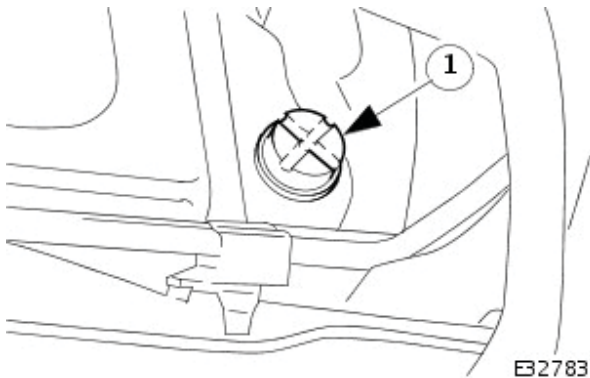

- Place a coolant drain tray on the floor, below the radiator drain plug.

1. Remove the radiator drain plug, and allow the coolant to drain.

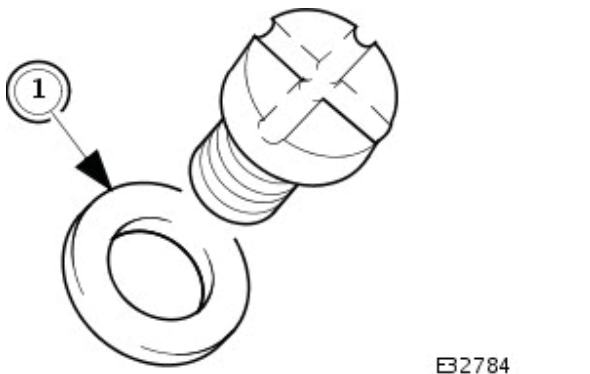

5. Fit a new seal to the drain plug.

1. Remove the seal from the drain plug, and clean the plug face.

- Fit a new seal.

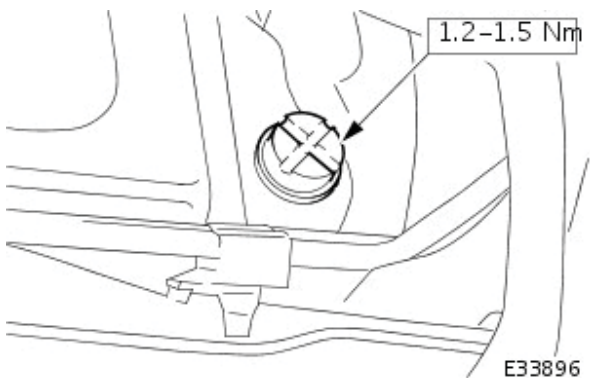

6. Refit the radiator drain plug.

- Clean any coolant from the underside of the vehicle. Remove the drain tray.

7. Lower the vehicle.

Refill

1. Refill the cooling system with a 50% solution of water and Jaguar Antifreeze / Corrosion Inhibitor ESD-M97B49-A.

1. Remove the threaded plug and Dowty washer from the charge air cooler fill point.

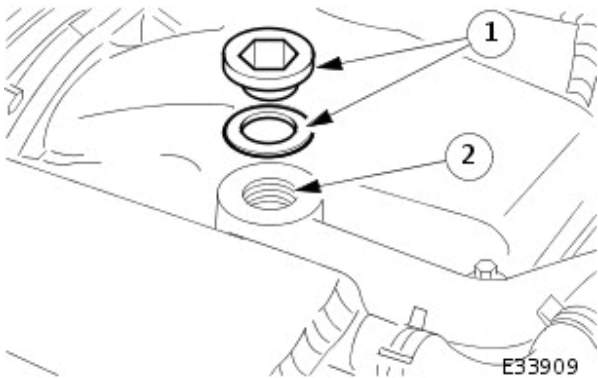

2. Fill the cooling system at the header tank until the level stabilises near the top of the charge air cooler fill point. This will take some time, as air is being purged from the system.

- Ensure that the header tank is full.

• **NOTE:** To ensure that air is not drawn into the system during the following operations:

- Do not remove the cap from the header tank whilst the charge air cooling system is open to atmosphere.
- Do not switch on the ignition when the charge air cooling system is open to atmosphere because the electrical cooling pump may draw air into the system.

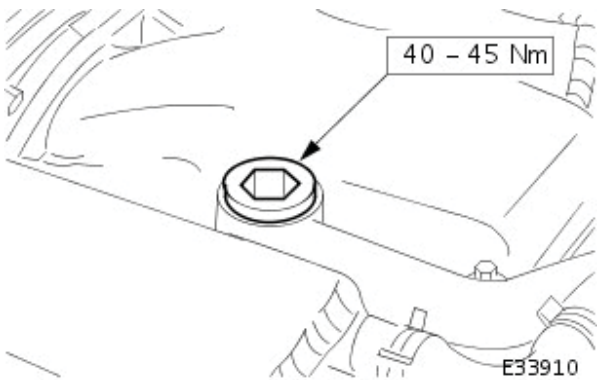

2. Fit the pressure cap to the header tank.

3. Pour coolant carefully into the charge air cooler fill point until the system is full.

- Fit the plug and washer to the fill point.

4. Remove the pressure cap from the header tank.

5. Switch on the ignition and switch off the climate control system.

- Leave the ignition switched on (do not start the engine) for at least 2 minutes to allow the air charge cooler electric water pump to operate and to purge any air from the air charge cooler radiator to the header tank. (This operation will be repeated later)

6. Switch off the ignition for at least 1 minute.

7. Leave the ignition switched on (do not start the engine) for at least 2 minutes to allow the air charge cooler electric water pump to operate and to purge any air from the air charge cooler radiator to the header tank.

8. Top up the cooling system.

1. Top up the header tank and fit the pressure cap.

2. Remove the plug from the air charge cooler fill point. Pour coolant carefully into the air charge cooler fill point until the system is full.

3. Fit the plug and washer to the fill point.

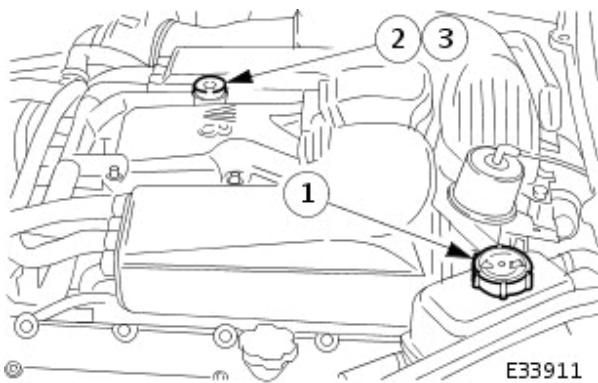

9. Run the engine at between 1500 and 2000 rpm until the cooling fans operate.
10. Switch on the climate control system, set to maximum heat, and check that heat is coming from the heater at the fascia vents or the footwell outlets.
11. Switch off the engine and allow it to cool down.
12. When cool, remove the pressure cap and top up the system as necessary at the header tank.
13. If necessary, fit new seals to the pressure cap.

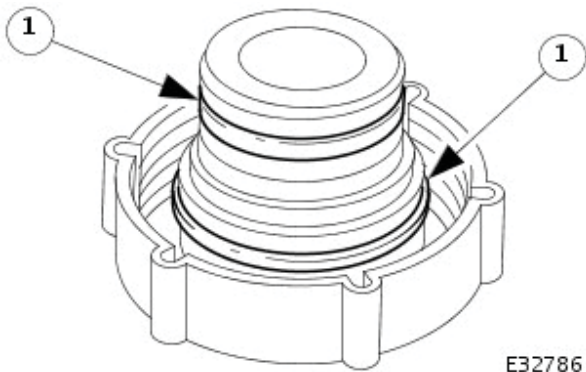

1. Remove both O-rings from the pressure cap.
 - Fit and fully seat new O-rings to the pressure cap. Fit the pressure cap.
14. Check that the pressure cap is fitted. Remove the plug from the air charge cooler fill point. Pour coolant carefully into the air charge cooler fill point until the system is full.
 - Fit the plug to the fill point, using a new Dowty sealing washer.
15. Remove the paintwork protection sheets and close the engine cover.