

E32750

4. Install coolant hoses.

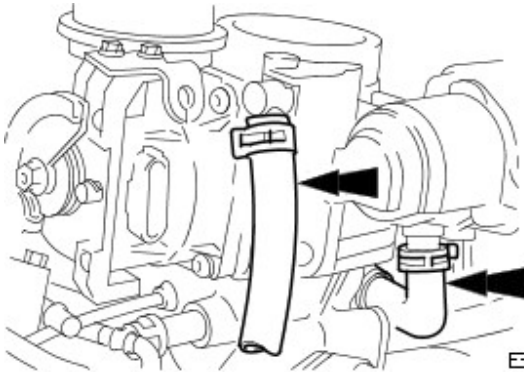

E32749

5. Reposition outer cable to abutment bracket.

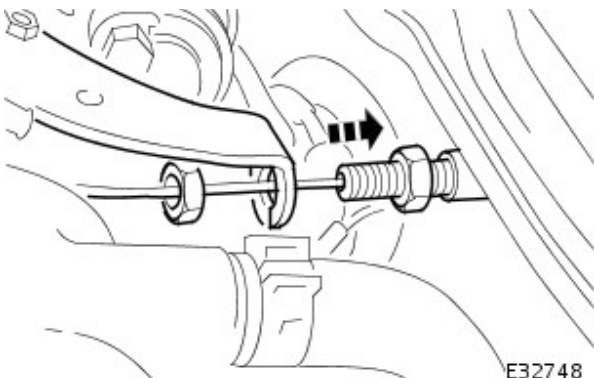

E32748

- Install but do not tighten adjusting nut.

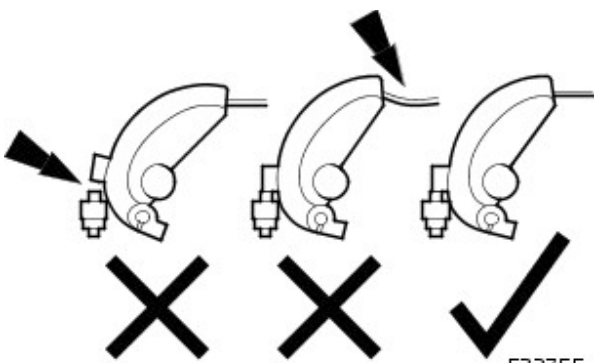

E32755

6. **⚠ CAUTION:** Under no circumstances should quadrant be held clear of throttle stop by cable tension.

- NOTE: Make sure there is neither tension nor slack in the cable.

Install throttle cable.

- Tighten locknut without altering setting or introducing twist into the cable outer.

7. Connect connectors and vacuum pipe.