

## Transmission Fluid Drain and Refill

### Special Service tools

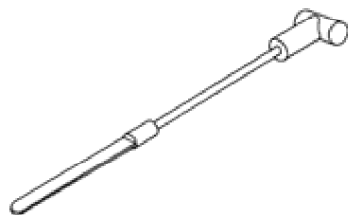

E31840

Dipstick  
307-379

1. Disconnect the battery ground lead.
2. Raise the vehicle for access.

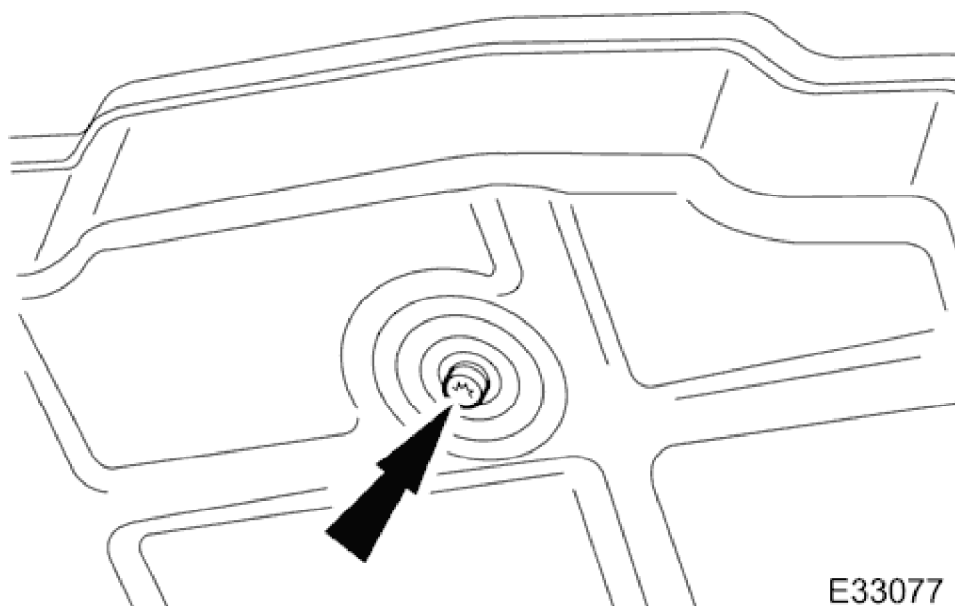

3. **NOTE:**

This procedure will not remove residual fluid from the torque converter.

Drain the transmission fluid.



**WARNING:**

**TRANSMISSION FLUID MAY CAUSE SEVERE BURNS, ENSURE THAT ALL SAFETY PROCEDURES ARE OBSERVED AND THAT THE RECEPTACLE FOR WASTE HAS SUFFICIENT CAPACITY.**

- Carefully remove the drain plug and discard the sealing washer.

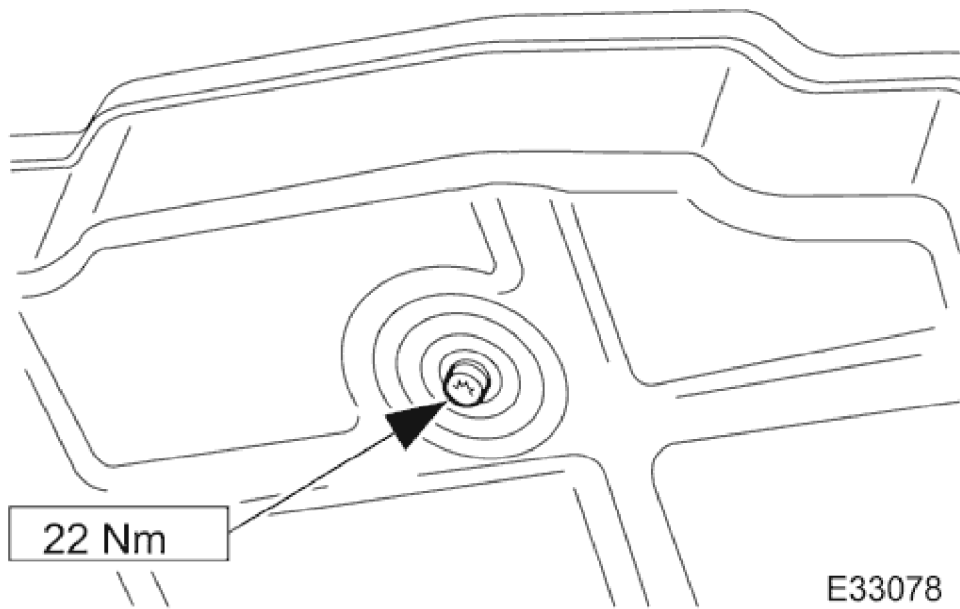

4. Refit the drain plug and tighten to the specified torque figure.
  - Use a new sealing washer.
5. Connect the PDU to monitor the fluid temperature

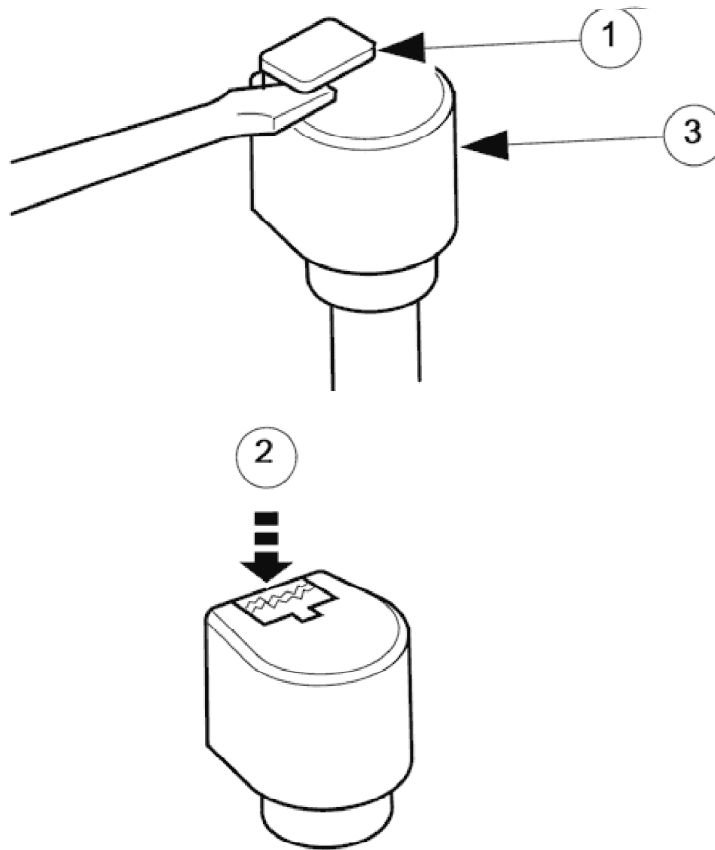

6. Access the dipstick tube.
  1. Break off the dipstick tube plug locking plate.
  2. Push the locking pin downward, into the plug.
  3. Remove the dipstick tube plug.
  - Push the locking pin through the tube plug and discard the pin.

E33079

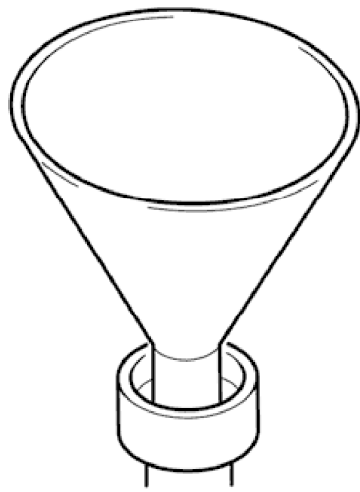

E33080

7.  **CAUTION:**  
**It is essential that only the specified fluid is used.**

Pour approximately 4,0 liters of fluid into the transmission.

600 - 750



E33003

8. Select P and start the engine.

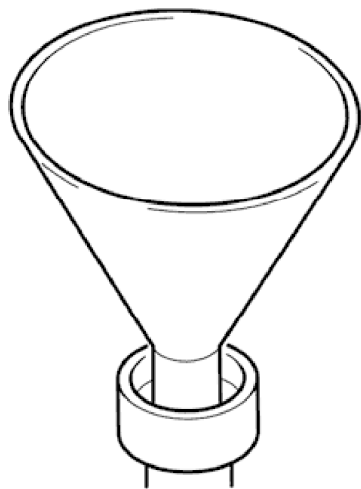

E33080

9. Pour approximately 3,0 liters of fluid into the transmission.

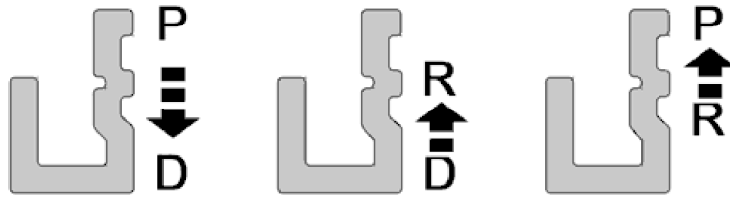

E33017

10. Cycle the gear selector:

- From P to D.
- From D to R.
- From R to P.

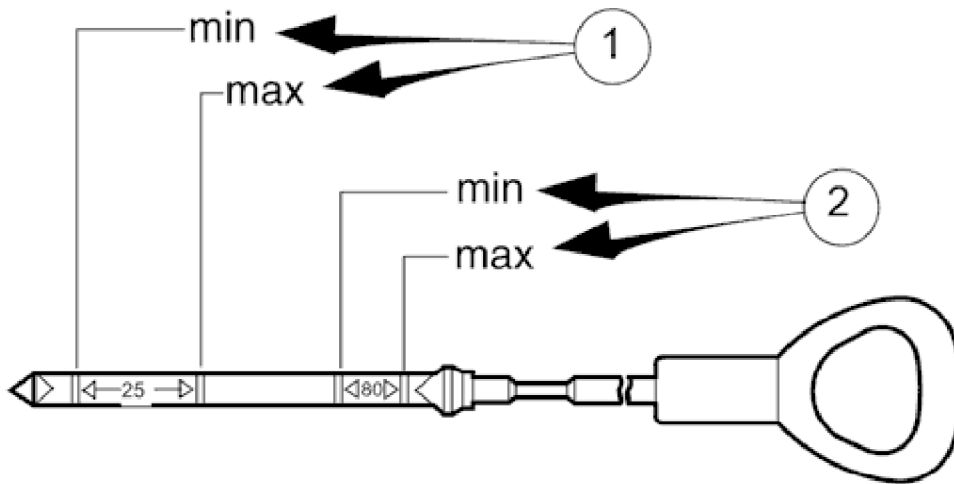

E33081

11. **NOTE:**

Temperature will ONLY be displayed in D or R.

Check the transmission fluid temperature to select the appropriate dipstick calibration.

1. MAX and MIN marks at 25°C fluid temperature.
2. MAX and MIN marks at 80°C fluid temperature.

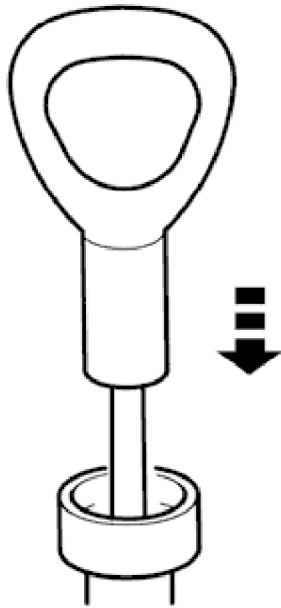

E33082

12. Check the transmission fluid level.

- Insert the dipstick (special tool 307 - 379) until it stops (tip contact with the fluid pan).
- Remove the dipstick and check the level.

**NOTE:**

Only use a lint free cloth to wipe the dipstick.

- Repeat this operation.

13. Correct the fluid level as required, noting that excess fluid **MUST** be removed.

14. **STOP** the engine and remove the dipstick.

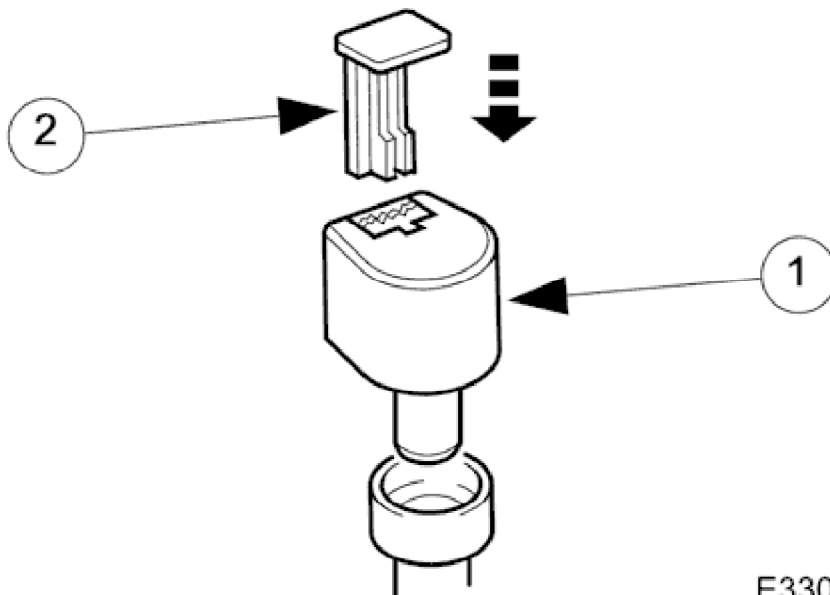

E33083

15. Seal the dipstick tube.

1. Seat the tube plug.
2. Engage and fully seat the new locking pin.

16. Check for leaks and remove spilt fluid.