

Instrument Panel and Console - Instrument Panel

Removal and Installation

Removal

1. Turn ignition switch to position II.
2. Motor driver and front passenger seats rearward.
3. Position steering wheel in straight ahead position and fully lower and extend steering column.
4. Turn ignition switch to position O.
5. Remove battery cover and disconnect ground cable from battery terminal. Refer to 86.15.19.
6. Remove 'J' gate finisher. Refer to 76.25.24.
7. Remove 'J' gate finisher retaining panel. Refer to 76.25.26.
8. Remove centre console veneer panel. Refer to 76.47.26.
9. Disconnect and remove radio.
10. Remove centre console switch module. Refer to 86.80.32.
11. Remove centre console. Refer to 76.25.01.
12. Slacken and remove centre console vent duct rear securing screw and withdraw duct assembly from air conditioning unit manifold.

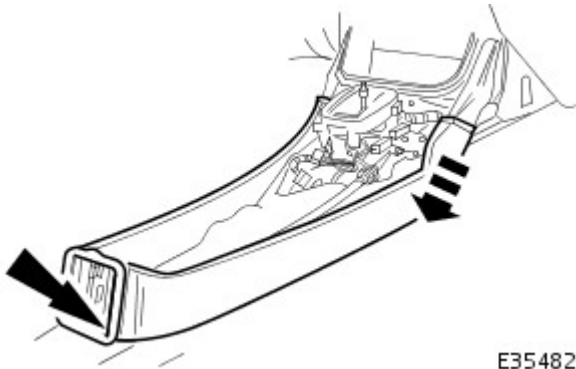

E35482

13.  **WARNING: BEFORE ANY AIRBAG/SRS SERVICE IS PERFORMED, AT LEAST ONE MINUTE MUST ELAPSE AFTER DISCONNECTION OF THE BATTERY CABLE, TO ALLOW DISSIPATION OF BACK-UP POWER SUPPLY ENERGY.**

Remove driver airbag. Refer to 76.73.39.

14. Remove steering wheel. Refer to Section 211-04.
15. Remove steering column lower cowl. Refer to 76.46.03.
16. Remove steering column upper cowl. Refer to 76.46.02.
17. Remove driver side underscuttle. Refer to 76.46.11.
18. Remove combined windshield wiper/washer switch and audible warning speaker assembly. Refer to 86.65.42.
19. Remove glovebox. Refer to 76.52.03.
20. Remove 'A' post lower trim pads. refer to 76.13.30.
21. Carefully withdraw driver stowage bin trim, remove bin securing screw and remove bin from fascia.

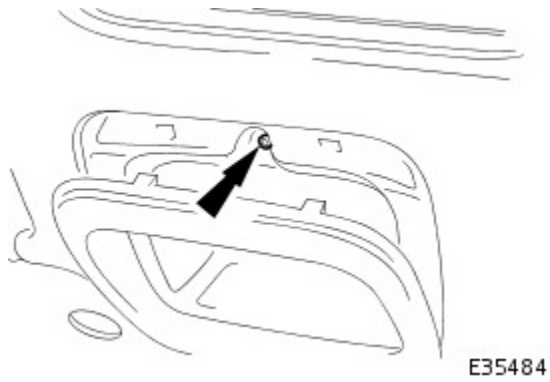

22. Accessing via driver stowage bin aperture, disconnect facia harness to centre console harness multiplugs.

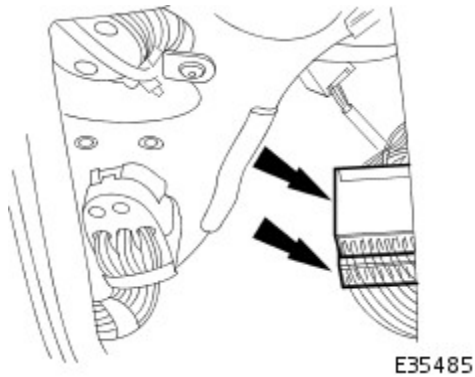

23. Release driver side facia harness to passenger compartment harness multiplug retaining lever and disconnect multiplug.

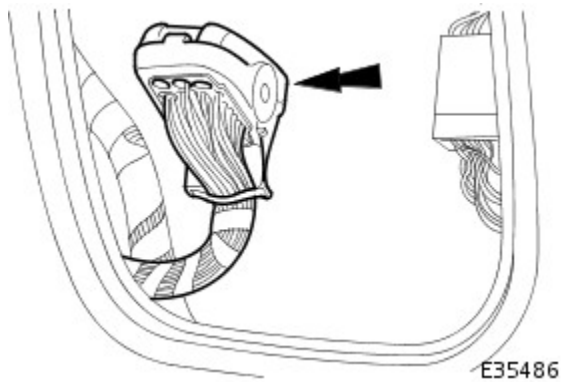

24. From RH side footwell, remove nut securing facia harness ground eyelet to tunnel front stud and disconnect eyelet from stud.

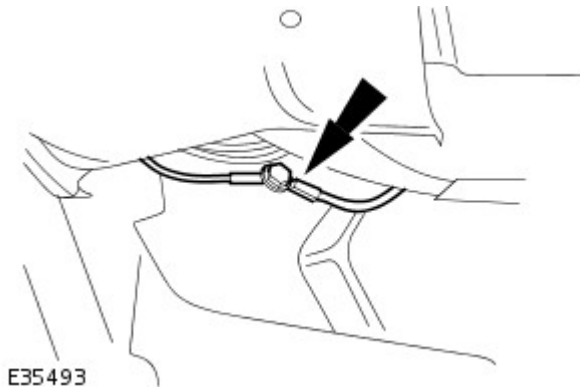

25. Remove steering column reach adjustment motor harness multiplug (yellow) from retaining bracket and disconnect multiplug.

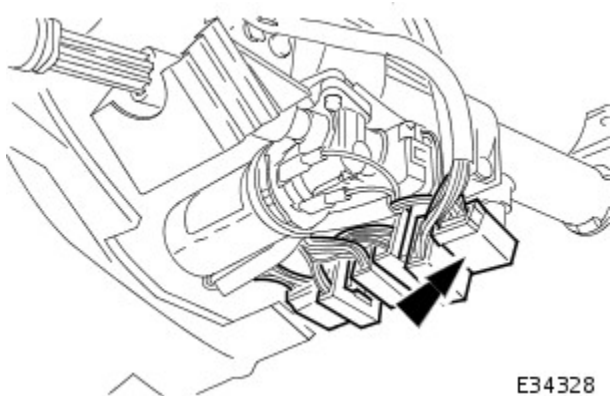

E34328

26. Remove steering column tilt adjustment motor harness multiplug from retaining bracket and disconnect multiplug.

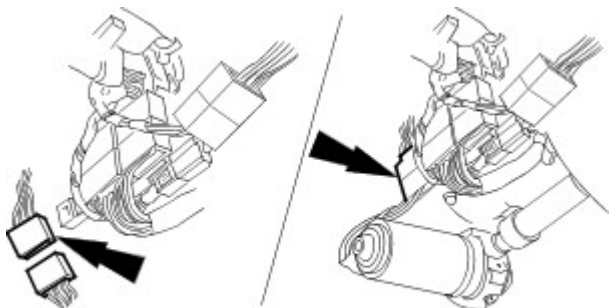

E35280

27. Remove bolt securing fascia mounting bracket to RH side of tunnel.

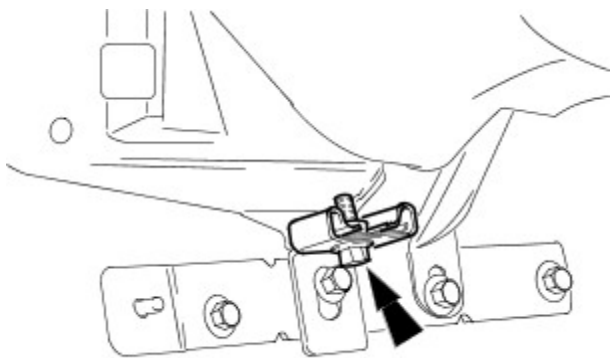

E33388

28. Remove fascia RH end aperture trim pad.

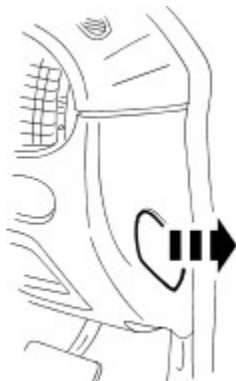

E35480

29.  CAUTION: The 'A' post fascia mounting brackets are pre-set to the body and must not under any circumstances be disturbed.

Remove two bolts securing fascia to RH 'A' post mounting bracket.

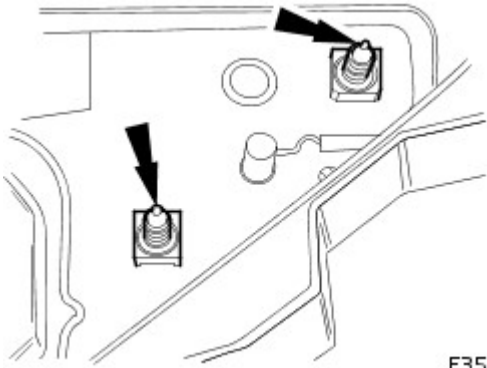

E35497

30. Disconnect and remove 'J' gate assembly for access. Refer to Section 307-05A N/A or 307-05B (S/C).

31. Remove two screws securing fascia to air conditioning unit.

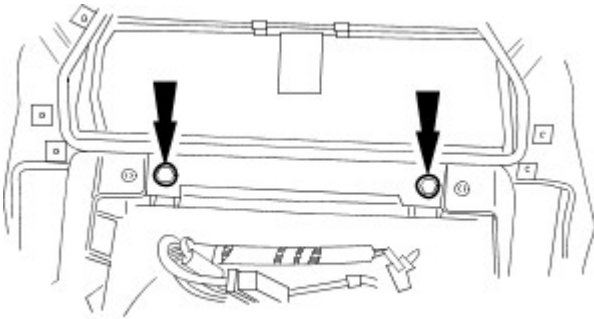

E35490

32. Remove bolts securing fascia to tunnel upper bracket and bracket to tunnel and remove bracket.

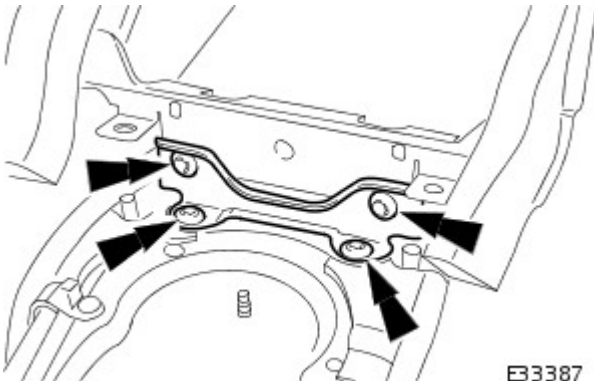

E33387

33. On passenger side, release fascia harness to passenger compartment harness multiplug retaining lever and disconnect multiplug.

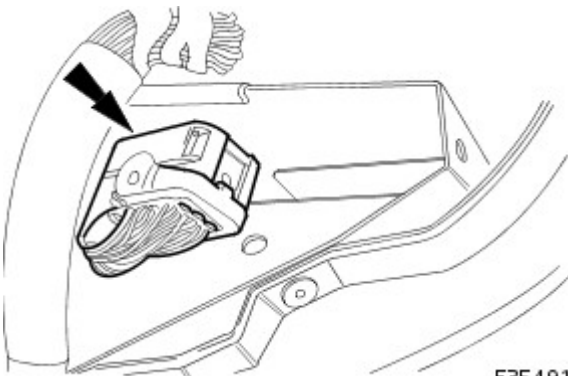

E35491

34. Remove fascia harness to engine management harness multiplugs (grey and white) from 'A' post lower retaining bracket and disconnect multiplugs.

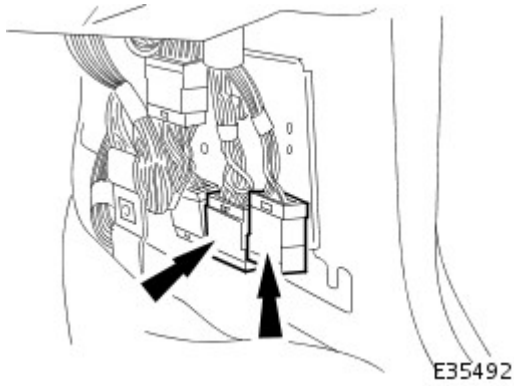

- 35.** From LH side footwell, remove nut securing fascia harness ground eyelet to tunnel front stud and disconnect eyelet from stud.

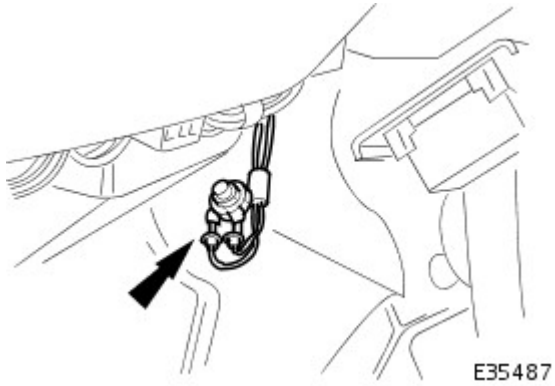

- 36.** Remove bolt securing fascia mounting bracket to LH side of tunnel.

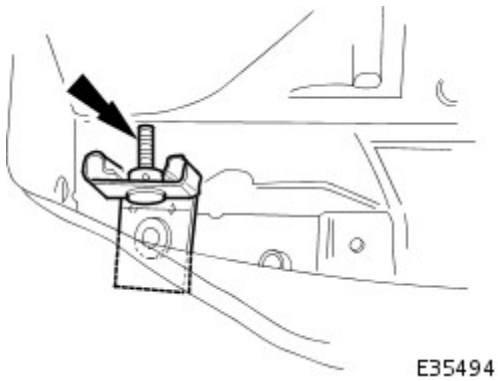

- 37.** Remove bolt securing fascia to bulkhead upper mounting bracket (between air conditioning control and body processor modules).

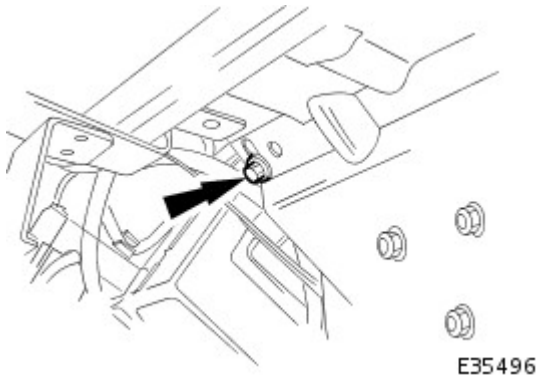

- 38.** Remove fascia LH end aperture trim pad.



E35481

39.  CAUTION: The 'A' post fascia mounting brackets are pre-set to the body and must not under any circumstances be disturbed.

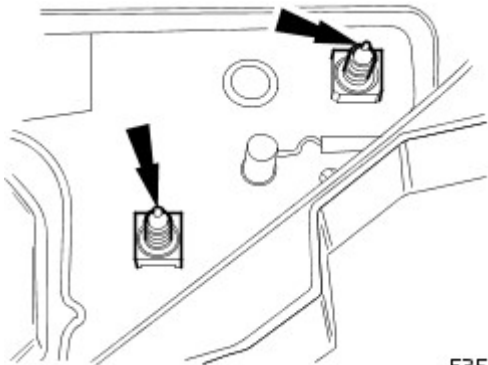

E35497

Remove two bolts securing fascia to LH 'A' post mounting bracket.

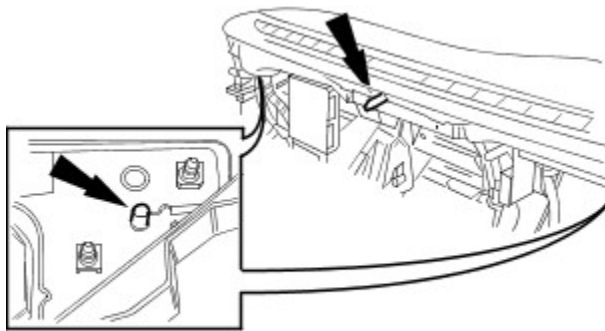

E35498

40. With assistance, carefully pull fascia assembly rearwards, withdrawing centre locating pin from front bulkhead and disengaging side dowels from slots in 'A' post brackets.

41. Remove fascia assembly from vehicle and place on clean bench correct way up, with back facing outward.

42. Disconnect key transponder module harness multiplug.



E35479

43. Remove key transponder module.

1. Remove two screws securing key transponder module to fascia and remove transponder module.

2. Remove and discard plastic inserts from fascia steel

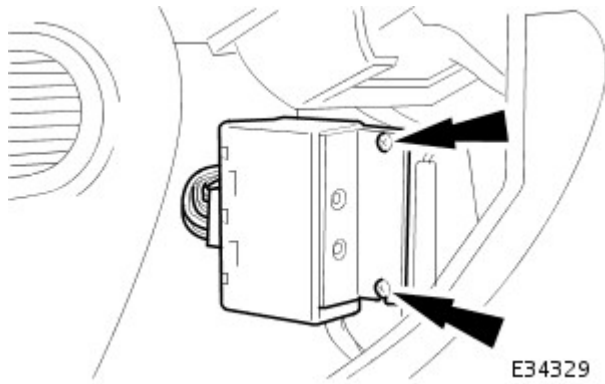

reinforcement.

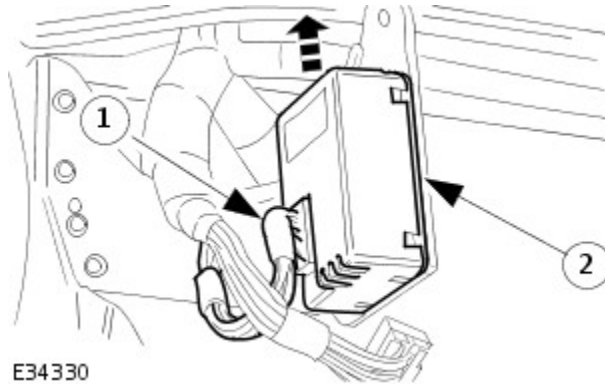

44. Remove illumination control module.

1. Disconnect illumination control module harness multiplug.
2. Slide module upwards to release it from fascia.

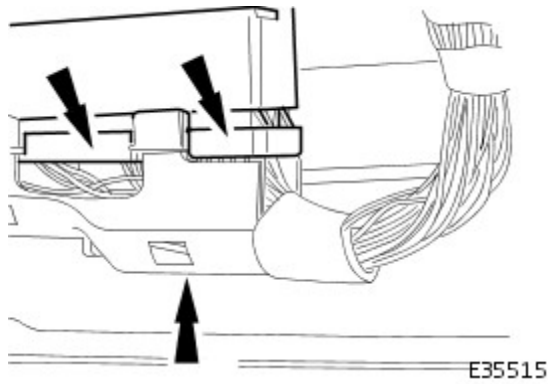

45. Remove captive bolt retaining body processor module harness multiplug and disconnect multiplug.

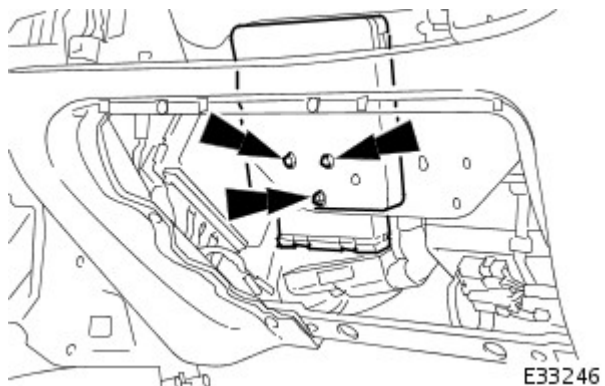

46. Remove three nuts securing body processor module to fascia and remove module.

- 47.** Turn fascia around to face outwards on bench.
- 48.** Remove instrument panel veneer. Refer to 76.47.24.
- 49.** Remove major gauge module. Refer to 88.20.24.
- 50.** Remove and discard instrument panel veneer retaining plastic inserts from fascia.
- 51.** Release in-car sensor/trunk release switch assembly from fascia for access and disconnect trunk release switch harness

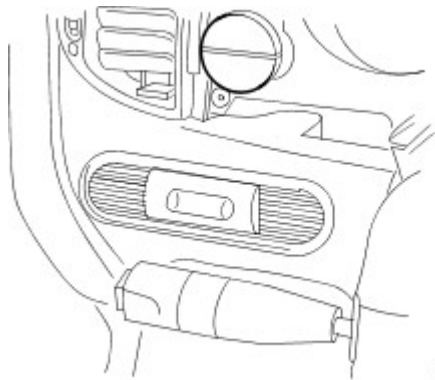

multiplug.

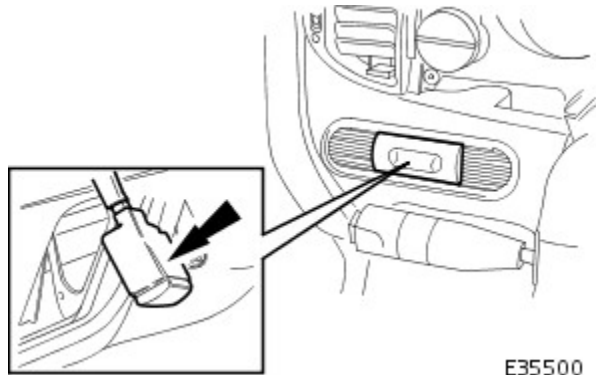

52. Withdraw in-car sensor from housing and remove housing/trunk release switch assembly.

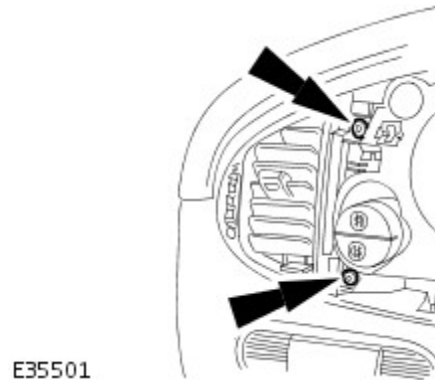

53. Remove LH vent/duct assembly from fascia.

- Remove two screws securing vent/duct assembly to fascia and remove assembly. Remove and discard screw retaining plastic inserts from fascia.

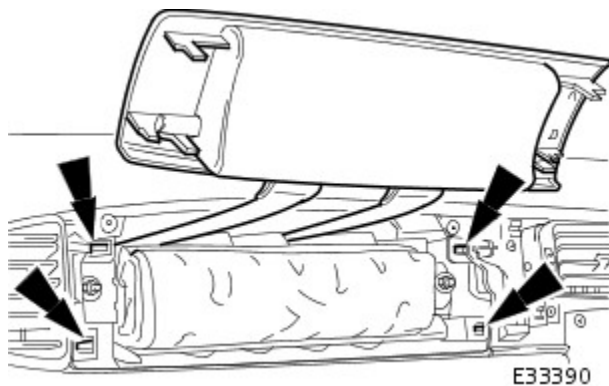

54. **⚠ WARNING: FOLLOWING DISCONNECTION OF THE BATTERY, A PERIOD OF AT LEAST ONE MINUTE MUST BE ALLOWED TO ELAPSE BEFORE ANY WORK IS CARRIED OUT ON AN AIR BAG MODULE.**

Remove passenger air bag deployment door for access, and remove and discard deployment door retaining clips from fascia.

55. Remove and discard four nuts securing passenger air bag module to fascia.

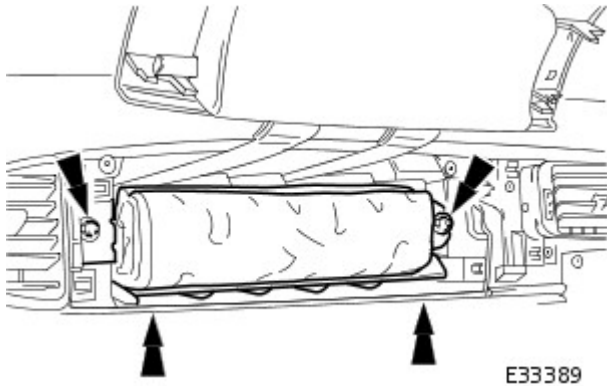

E33389

56. Partially withdraw airbag module, disconnect link harness multiplug and remove airbag from fascia.

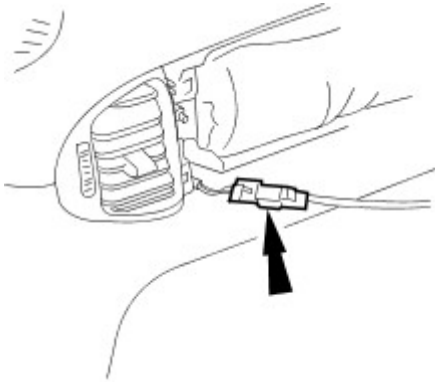

E35813

57. Remove RH vent/duct assembly from fascia.

- Remove two screws securing vent/duct assembly to fascia and remove assembly. Remove and discard securing screw plastic inserts from fascia.

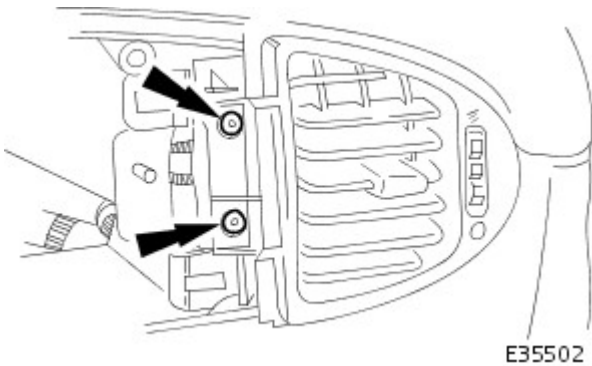

E35502

58. Carefully withdraw centre vent veneer panel.

59. Remove four screws securing centre vent to fascia.

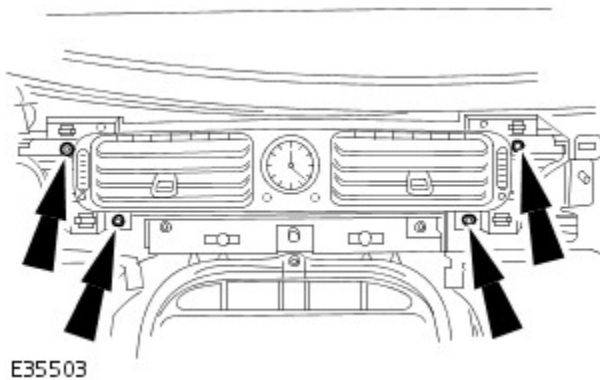

E35503

60. Remove centre vent.

- Withdraw centre vent for access, disconnect clock harness multiplug and remove vent.
- Remove and discard centre vent retaining screw plastic inserts from fascia.

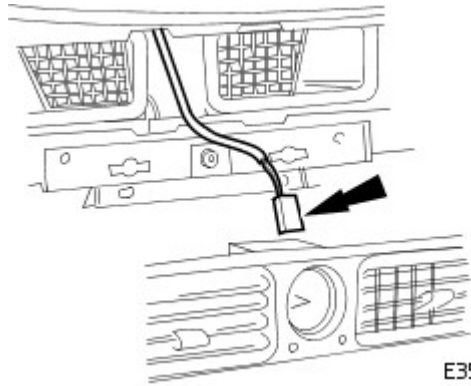

E35504

- Remove clock from centre vent.

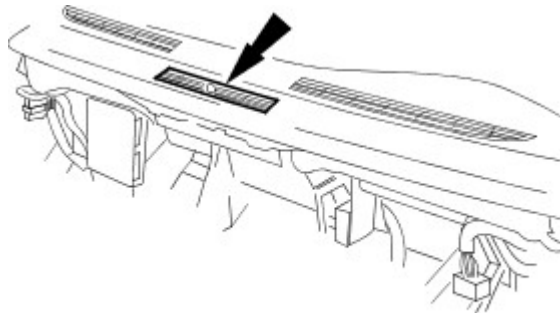

E35506

61. Reposition fascia face down on bench.

62. Withdraw centre defrost vent for access, release solar sensor harness multiplug from retaining clip and disconnect multiplug.

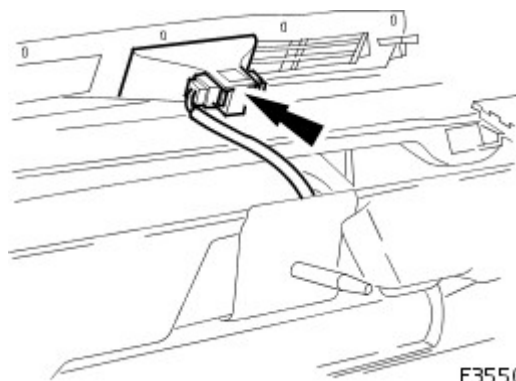

E35507

63. Remove centre defrost vent complete with solar sensor, and remove vent retaining clips from fascia.

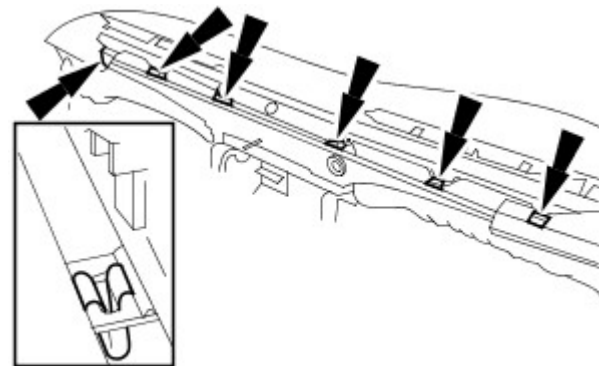

E35508

64. Carefully remove left and right hand defrost vents from fascia and remove vent retaining clips from fascia.

65. Carefully remove left and right hand top vents from fascia.

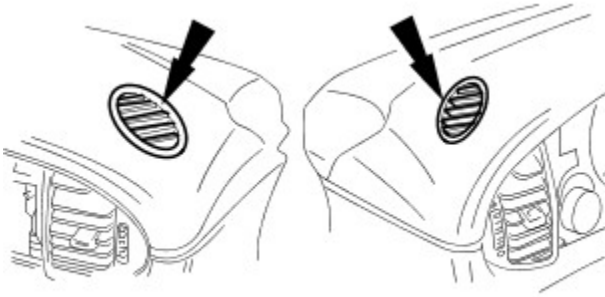

E35509

66. Remove screws securing LH and RH face level air ducts to fascia and remove ducts.

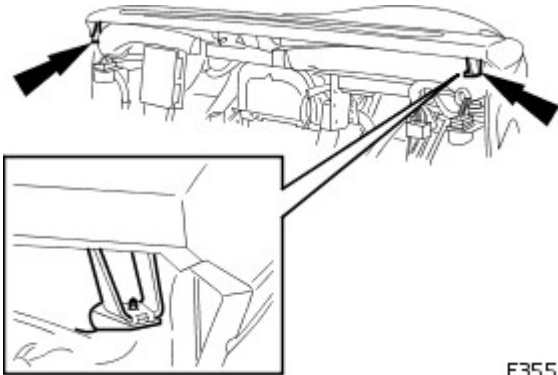

E35505

67. Remove four nuts securing air distribution box to fascia.

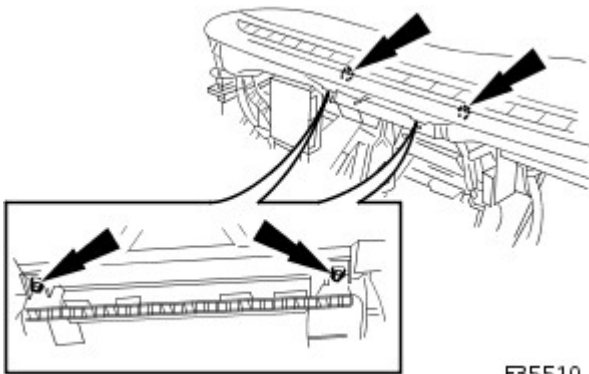

E35510

68. Position air distribution box for access, disconnect multiplug and remove air distribution box from fascia.

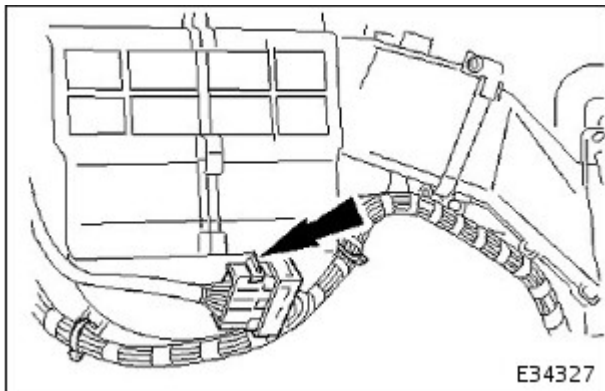

E34327

69. Remove two screws securing aspirator motor assembly to fascia

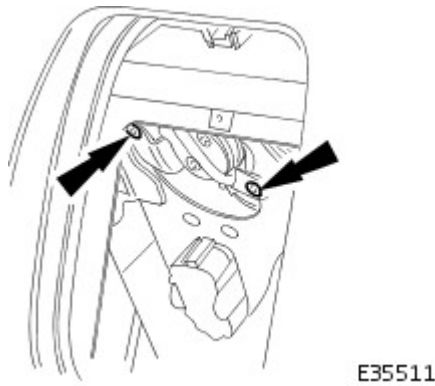

E35511

70. Disconnect aspirator harness multiplug and remove aspirator, carefully routing hose through facia aperture.

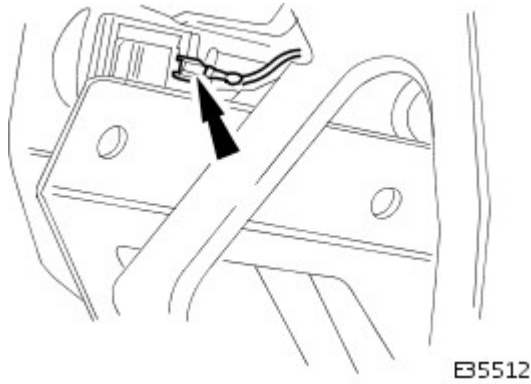

E35512

71. Release facia harness multiplugs from retaining brackets on RH side of facia and slacken and remove two nuts securing harness to facia.

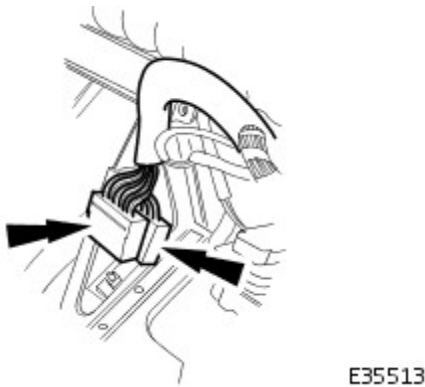

E35513

72. Remove solar sensor harness grommet from facia and route harness multiplug through aperture. Release multiplug from retaining bracket on LH side of facia

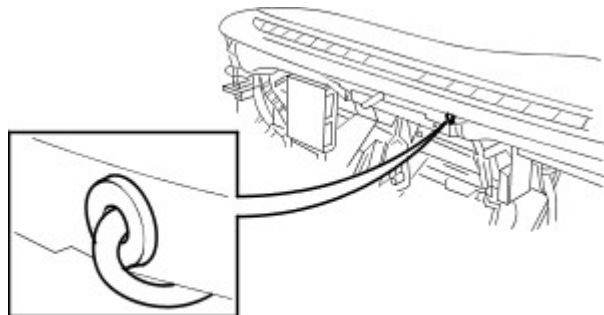

E35514

73. Noting positions, remove all harness retaining clips from facia.

74. Note layout of harness, then remove harness from facia.

Installation

1. Route harness in facia as previously noted.
2. Install all harness to facia retaining clips.

3. Install solar sensor harness multiplug on LH retaining bracket.
4. Pass solar sensor harness multiplug through facia aperture. Install solar sensor harness grommet.

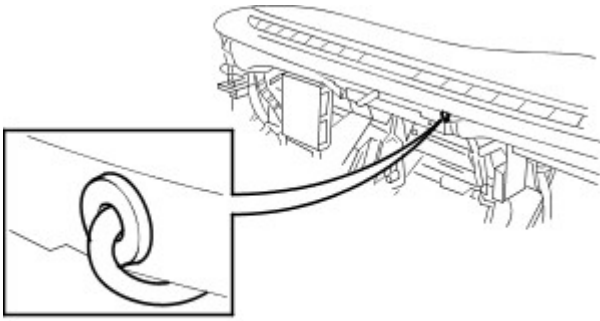

E35514

5. Install facia harness multiplugs to RH retaining brackets and install harness securing nuts.



E35513

6. Install aspirator motor assembly in facia, routing hose through aperture, and install securing screws.



E35511

7. Connect aspirator harness multiplug to facia harness.

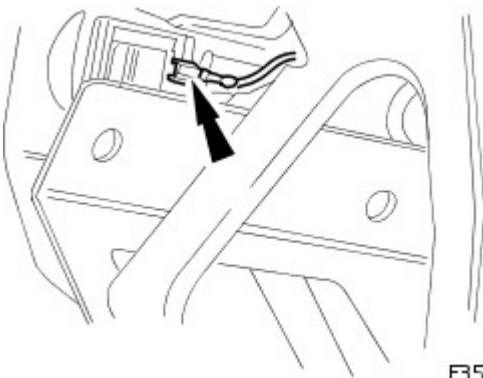

E35512

8. Position air distribution box in facia and connect multiplug to facia harness.

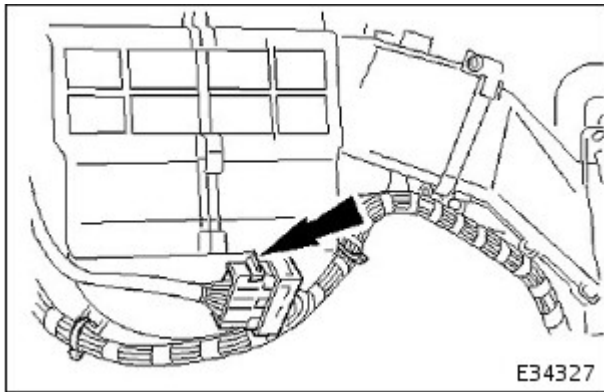

9. Fully seat air distribution box and install securing nuts.

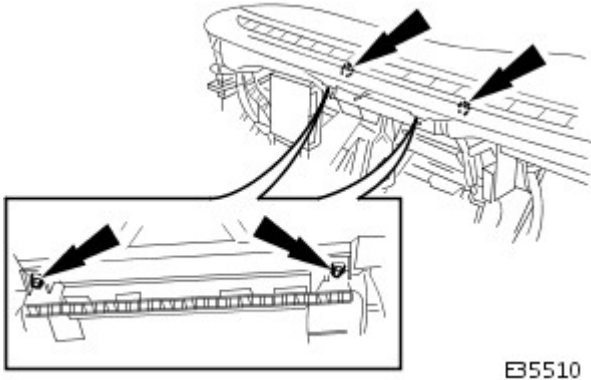

10. Install LH and RH air distribution box/facia side vent ducts and install securing screws.

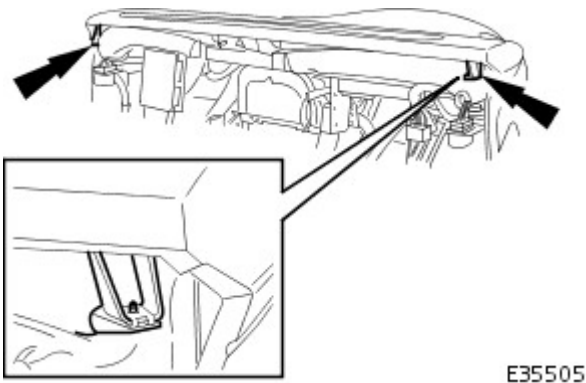

11. Install LH and RH top vents on facia.

12. Install all defrost vent retaining clips to facia.

13. Install LH and RH windshield defrost vents to facia

14. Position centre defrost vent/solar sensor assembly, connect sensor harness multiplug to facia harness, install multiplug on retaining clip and fully seat assembly in facia.

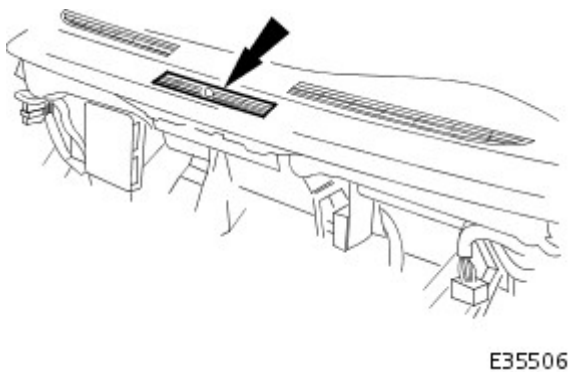

15. Reposition facia right way up on bench.

16. Position face level air ducts in facia and install securing screws.

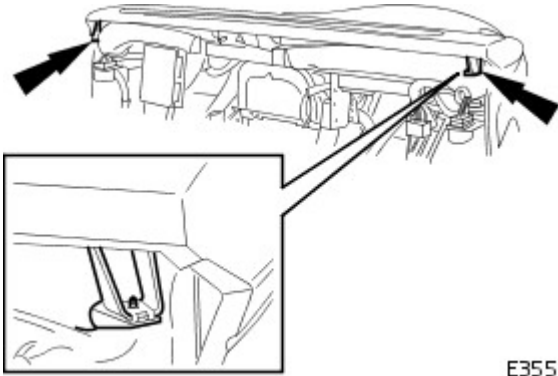

E35505

17. Install centre vent/clock assembly.

1. Install new centre vent retaining screw inserts in fascia.
2. Position centre vent/clock assembly at fascia and connect clock harness multiplug to fascia harness.

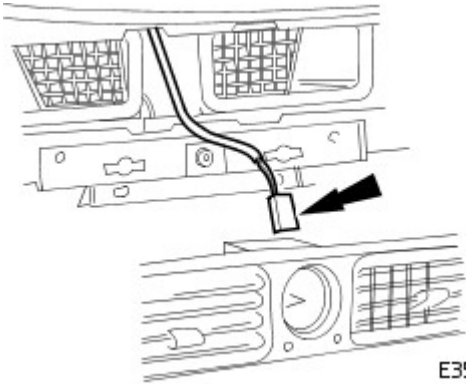

E35504

18. Position centre vent/clock assembly in fascia and install securing screws.

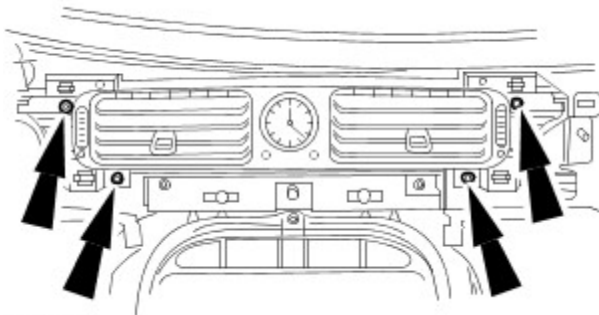

E35503

19. Install RH side vent/duct assembly.

1. Install new RH side vent/duct retaining screw inserts in fascia.
2. Position RH side vent in fascia and install securing screws.

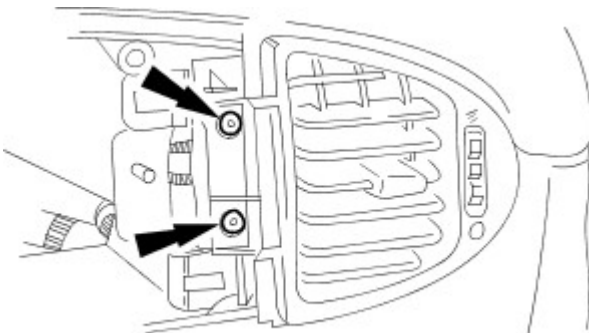

E35502

- 20.** Install new LH side vent/duct retaining screw inserts in fascia.
- 21.** Position LH side vent/duct in fascia and install securing screws.
- 22.** Position passenger air bag module and deployment door assembly in fascia aperture. and install four new securing nuts.

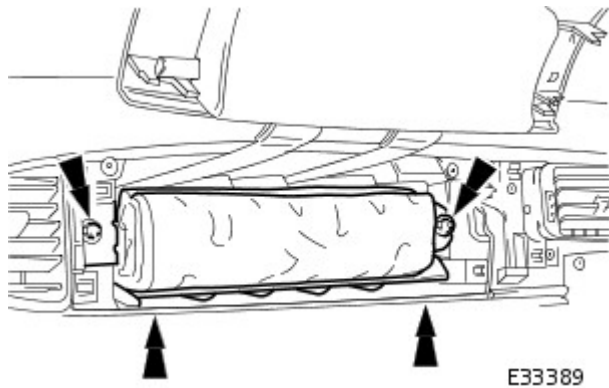

E33389

23.  **WARNING: ENSURE THAT THE AIR BAG AND RETAINING CLIPS ARE FULLY SEATED.**

Install deployment door.

- Install and fully seat deployment door retaining clips in fascia.
- Install and fully seat deployment door in clips.

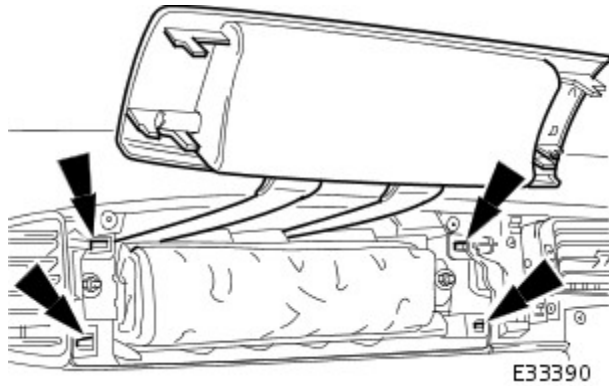

E33390

24. Position trunk release switch/housing at fascia and connect in-car sensor to housing.

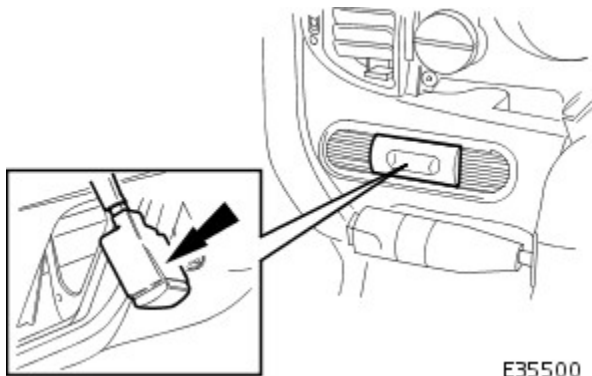

E35500

25. Connect trunk release switch multiplug to fascia harness and install in-car sensor/trunk release switch assembly to fascia.

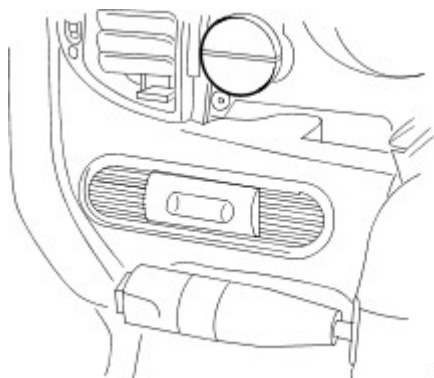

E35499

26. Install new major gauge module retaining screw inserts to fascia.

27. Install major gauge module in fascia. Refer to 88.20.24.

28. Install instrument panel veneer panel. Refer to 76.47.24.

29. Reposition fascia on bench with back facing outwards.

30. Position body processor module in fascia and install securing nuts.

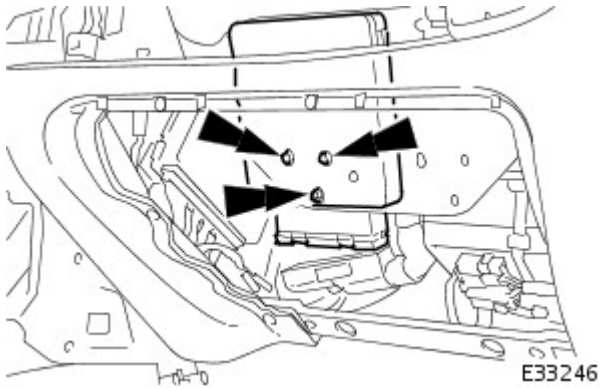

E33246

31. Connect body processor module harness multiplug to facia harness and tighten captive securing bolt.

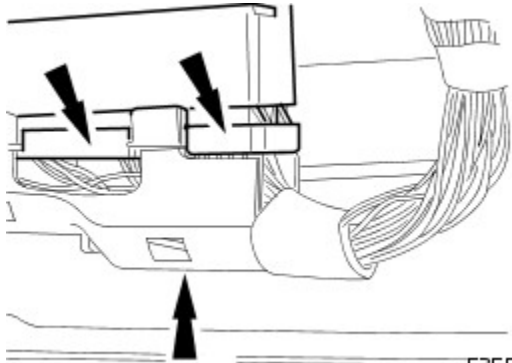

E35515

32. Install illumination control module on facia. mounting.

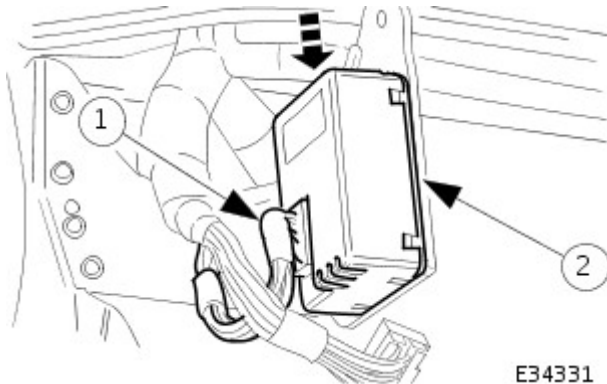

E34331

1. Connect module to facia harness multiplug.
2. Slide module downward to secure on mounting bracket.

33. Install new key transponder module securing screw plastic inserts to facia. Position key transponder module in facia and install securing screws.

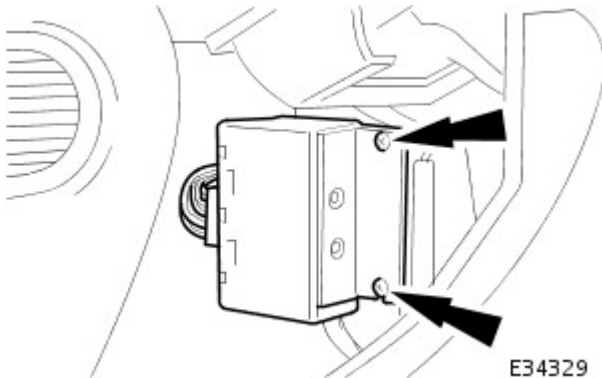

E34329

34. Connect key transponder module harness multiplug to facia harness.



E35479

35. With assistance, position fascia in vehicle, align side dowels with slots in 'A' post brackets, and centre pin with bulkhead aperture, and push fully forward.

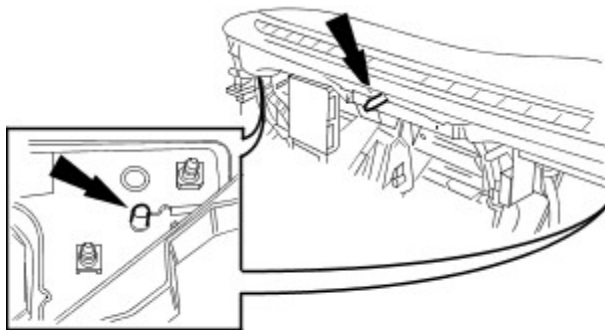

E35498

36.  CAUTION: The 'A' post fascia mounting brackets are pre-set to the body and must not under any circumstances be disturbed.

Install bolts securing fascia to RH 'A' post bracket and tighten to 22-28Nm.

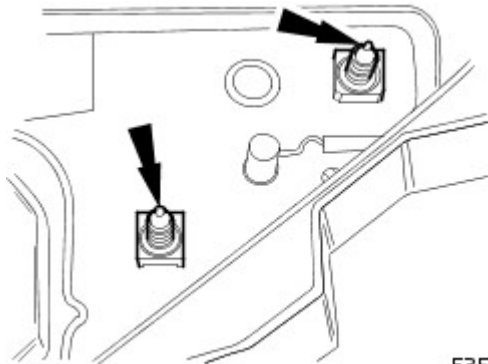

E35497

37. Install trim pad on fascia RH end aperture.

38. Install bolt securing fascia bracket to RH side of tunnel and tighten to 7-10Nm.



E33388

39. Install fascia centre support bracket.

- Position centre bracket on top of tunnel and install but do not tighten securing bolts.
- Install fascia to centre mounting bracket bolts and tighten to 22-28Nm.

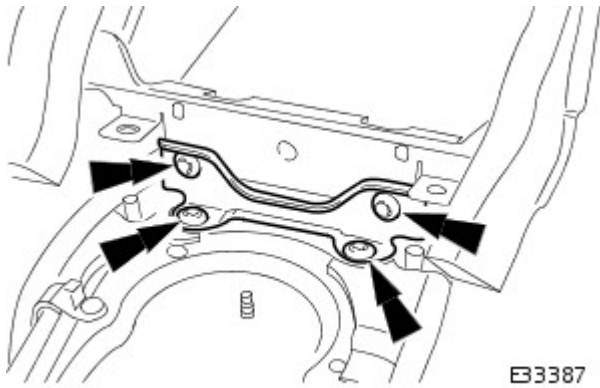

- Finally tighten centre mounting bracket to tunnel securing bolts to 22-28Nm.

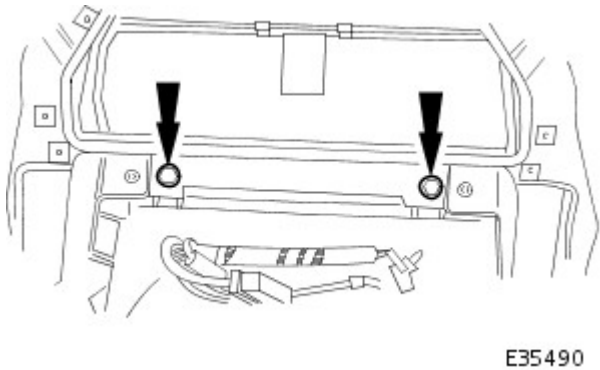

40. Install fascia to air conditioning unit securing screws.

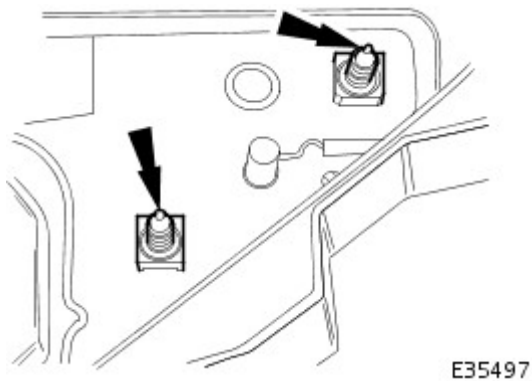

41.  CAUTION: The 'A' post fascia mounting brackets are pre-set to the body and must not under any circumstances be disturbed.

Install bolts securing fascia to LH 'A' post bracket and tighten to 22-28Nm.

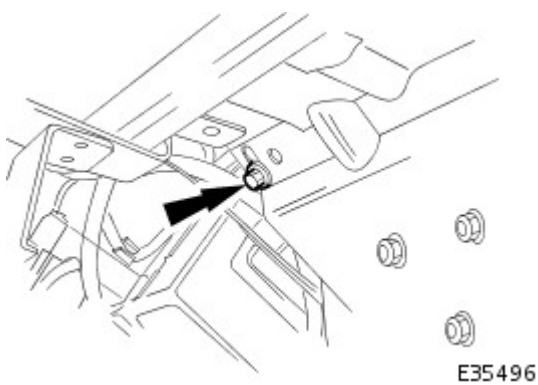

42. Instal seat trim pad to fascia RH end aperture.
43. Install bolt securing fascia mounting bracket to bulkhead adjacent to body processor.

44. Position ground cable eyelet on LH 'A' post stud and install securing nut.

45. Connect passenger side fascia harness to engine management harness multiplugs (white and grey) and install multiplugs on lower 'A' post retaining bracket.

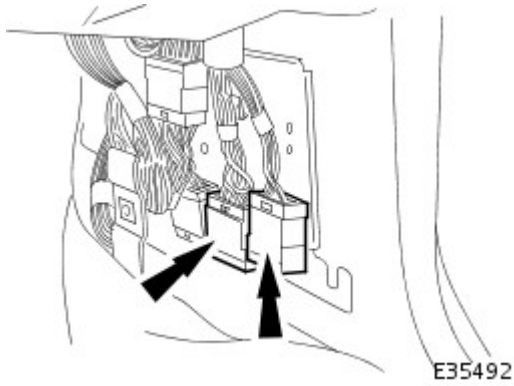

46. Connect passenger side facia harness to passenger compartment harness multiplug and secure with retaining lever.

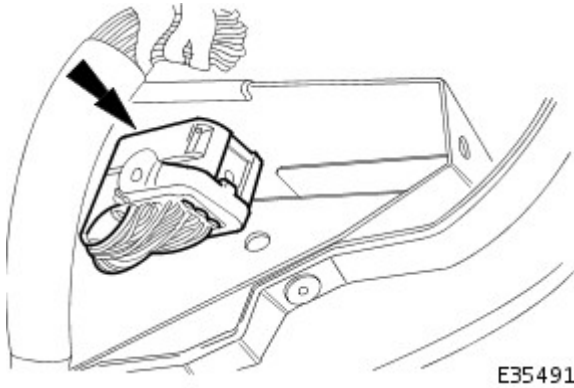

47. Install trim pad on passenger side lower 'A' post. Refer to 76.13.30.

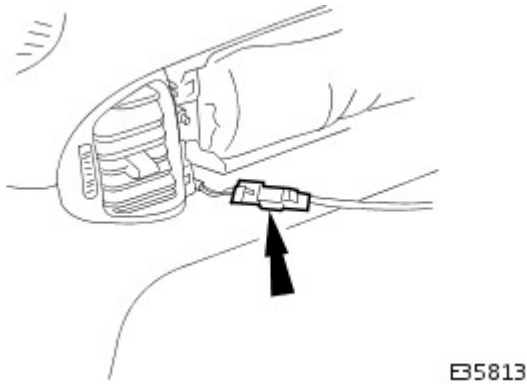

48. Connect passenger air bag link harness multiplug.

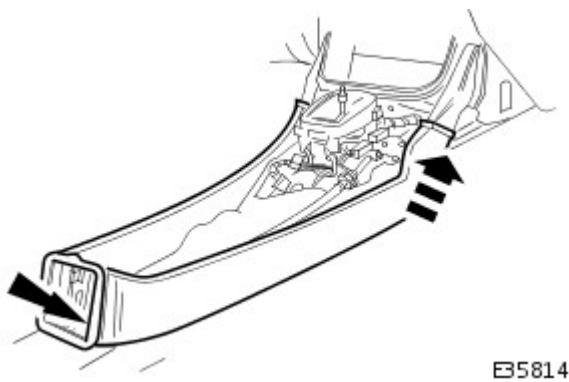

49. Install passenger glovebox assembly. Refer to 76.52.03.

50. Install 'J' gate assembly. Refer to 76.25.24 and 76.25.26.

51. Position centre console rear vent duct in air conditioning unit and install rear securing screw.

52. Install centre console. Refer to 76.25.01.

53. Install centre console switch module. Refer to 76.13.30.

- 54. Install radio. Refer to 86.50.03.
- 55. Install facia centre veneer panel. Refer to 76.47.06.
- 56. Install centre console veneer panel. Refer to 76.47.26.
- 57. Install 'J' gate finisher retaining panel. Refer to 76.25.26.
- 58. Install 'J' gate surround. Refer to 76.25.24, Section 307-05A (N/A), 307-05B (S/C).
- 59. Connect steering column tilt motor harness multiplug and install multiplug on retaining bracket.

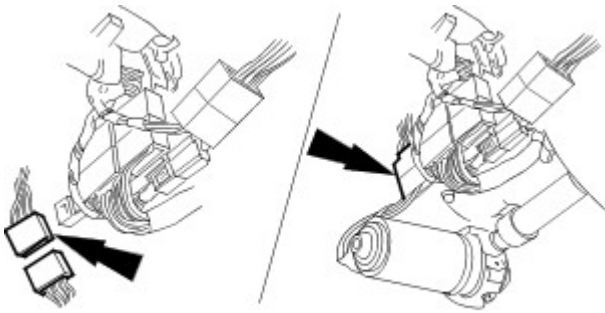

E3280

- 60. Connect steering column reach motor harness multiplug and install multiplug on retaining bracket.

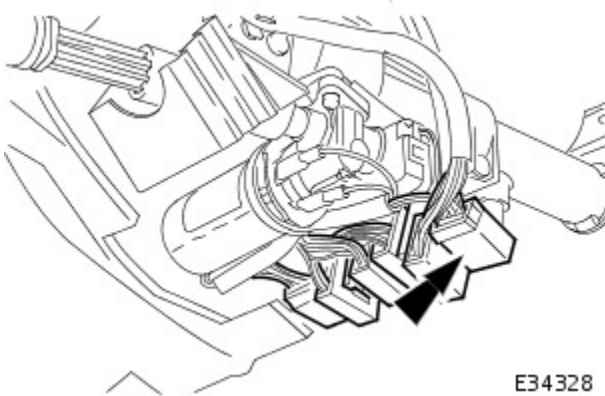

E34328

- 61. Position ground cable eyelet on RH 'A' post stud and install securing nut.
- 62. Connect driver side facia harness to passenger compartment harness multiplug and secure with retaining lever.

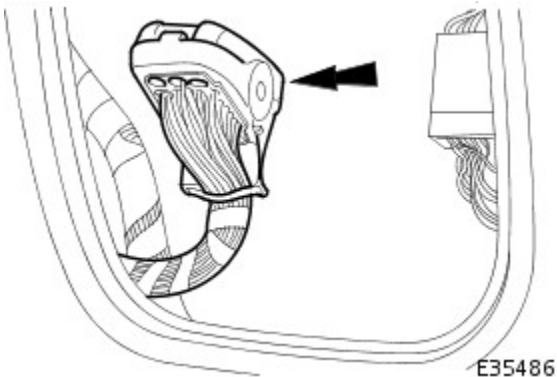

E35486

- 63. Connect driver side facia harness to console harness multiplugs.

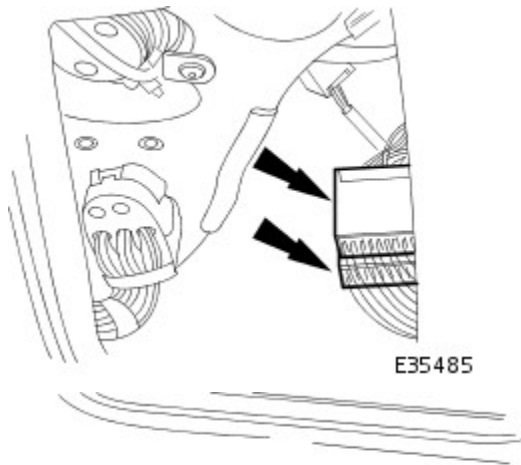

64. Position driver stowage bin in fascia, install securing screw and fully seat trim.

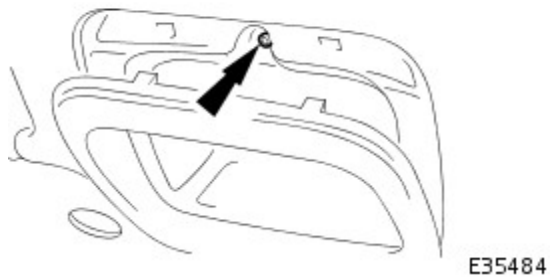

65. Install trim pad on driver side lower 'A' post. Refer to 76.13.30.

66. Install driver side underscuttle. Refer to 76.46.11.

67. Install combined windshield wiper/washer switch and audible warning speaker assembly. Refer to 86.65.42.

68. Install steering column upper cowl. Refer to 76.46.02.

69. Install steering column lower cowl. Refer to 76.46.03.

70. Install steering wheel. Refer to 211-04.

71. Install driver side airbag. Refer to 76.73.39.