

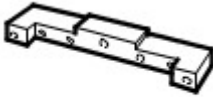



# Engine - Primary Timing Chain LH4.0L NA V8 - AJ27

In-vehicle Repair

Special Tool(s)	
 E36401	Camshaft setting 303 - 530
 E36402	Timing chain tensioning 303 - 532
 E36407	Wedges, primary chain 303 - 533
 E36408	Crankshaft setting 303 - 531

## Removal

1. Open the engine compartment and fit paintwork protection sheets.
2. Set the engine compartment cover to the service access position.
3. Disconnect the battery ground cable.

- Remove the battery cover.

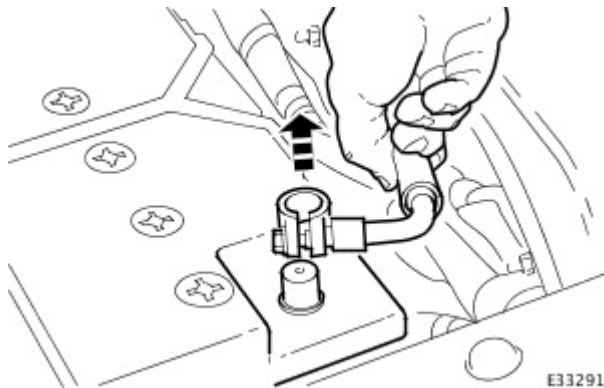

4. Remove the Timing Cover. Refer to Operation 12.65.01 in this Section.
5. Remove the VVT bush carrier from the A-Bank.

1. Remove the three bolts which secure the carrier to the cylinder block.

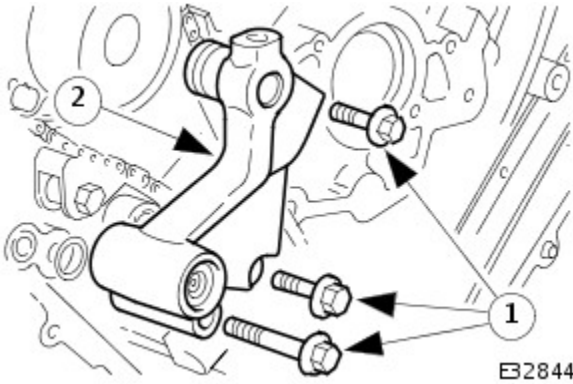

2. Release the carrier from the two ring dowels and remove it.

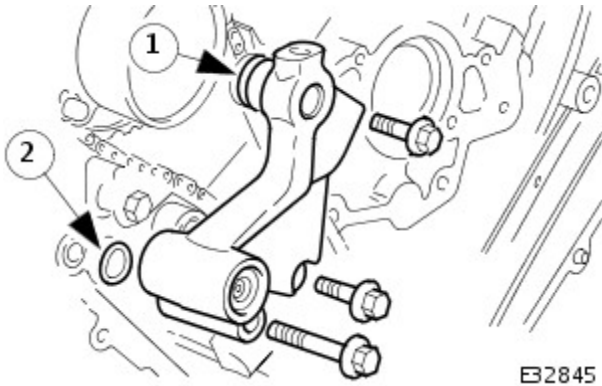

6. Remove the seals from the bush carrier.

1. Remove the sealing ring (scarf jointed) from the carrier bush groove.

2. Remove the O-ring from the carrier oil-way recess.

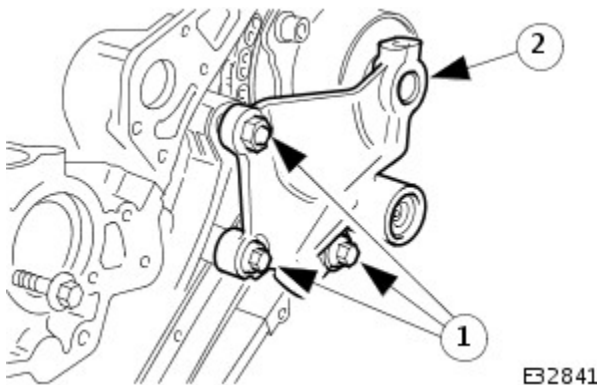

7. Remove the VVT bush carrier from the B-Bank.

1. Remove the two bolts and one nut which secure the carrier to the cylinder block.

2. Release the carrier from the two ring dowels and remove it.

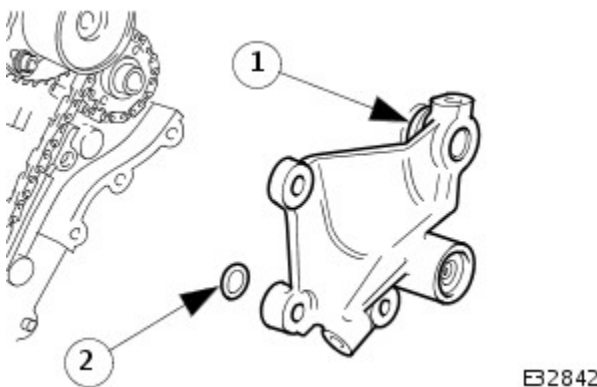

8. Remove the seals from the bush carrier.

1. Remove the sealing ring (scarf jointed) from the carrier bush groove.

2. Remove the O-ring from the carrier oil-way recess.

9. Raise the vehicle on a ramp.

10. Remove the crankshaft position sensor.

1. Remove the bolt which secures the crankshaft position sensor to the flywheel housing.

1. Remove the sensor and allow it to hang free under the engine.

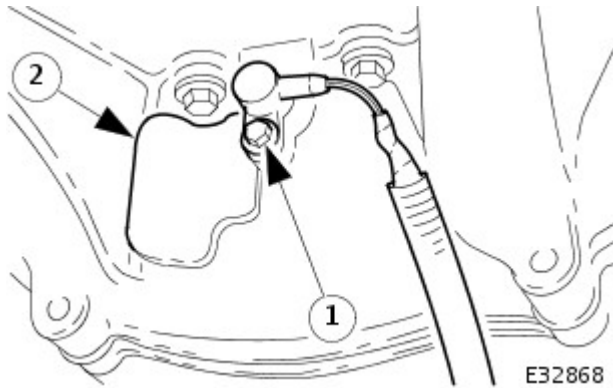

2. Remove the access grommet (for torque converter bolts) from the housing.

11. Fit the damper securing bolt (old one) to the crankshaft, hand-tight only.

12. Rotate the crankshaft until the triangular arrow indent on the drive plate is visible through the access hole; confirm that the timing flat on each camshaft is uppermost.

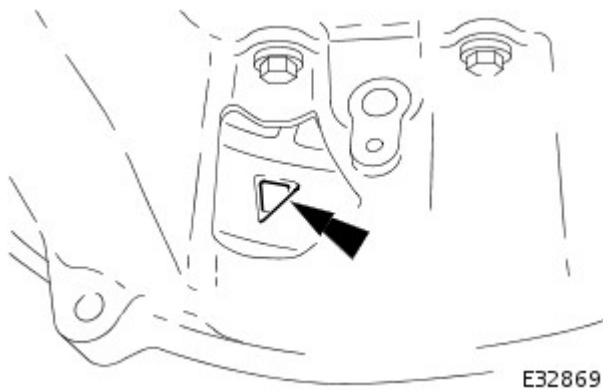

13. Fit the crankshaft setting peg 303 - 531 to the crankshaft position sensor location.

1. Fit the crankshaft setting peg 303 - 531.
  1. Position the crankshaft so that the setting peg engages fully into the timing slot.
2. Fit and tighten the bolt to secure the setting peg.



14. Remove the damper securing bolt from the crankshaft.

15. Lower the vehicle on the ramp.

16. Fit the camshaft locking tool 303 - 530 to the A-Bank camshafts, aligning the shafts slightly as necessary.

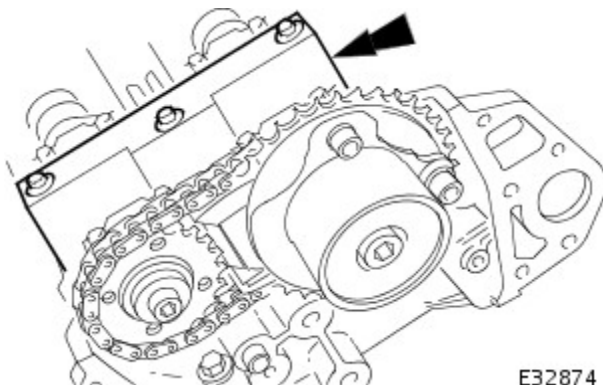

17. Loosen the bolt which secures the sprocket to the camshaft.

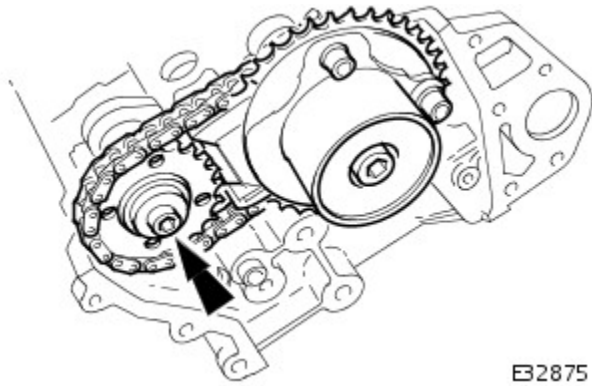

E32875

18. Loosen the bolt which secures the VVT unit to the camshaft.

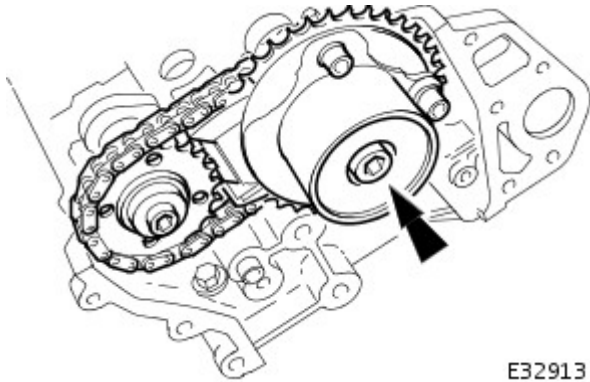

E32913

19. Remove the primary chain tensioner bolts.

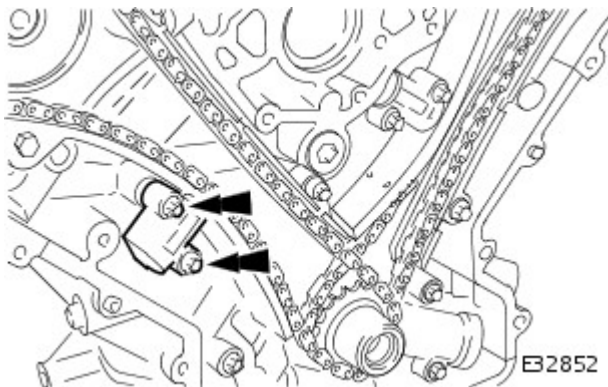

E32852

20. Remove the tensioner assembly.

1. Remove the tensioner.
2. Remove the tensioner back-plate.

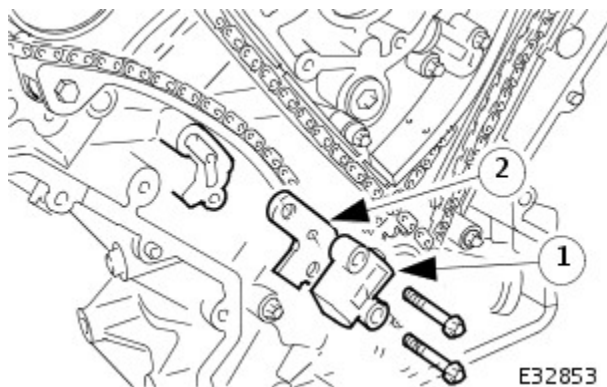

E32853

21. Remove the chain tensioner blade.

1. Remove the pivot bolt which secures the tensioner blade.
2. Remove the tensioner blade.

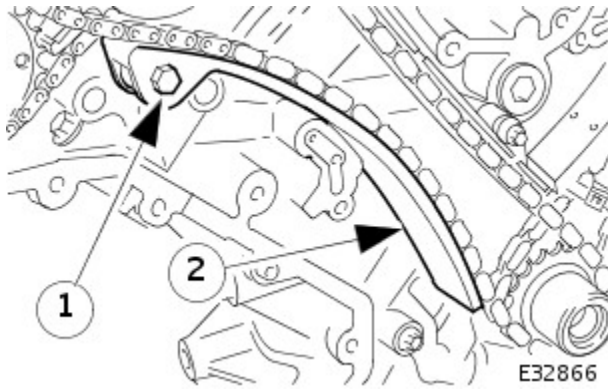

22. Remove the chain from the VVT unit and from the crankshaft pulley.

23. Remove the camshaft locking tool 303 - 530 and transfer it to the B-Bank camshafts, aligning the shafts slightly as necessary.

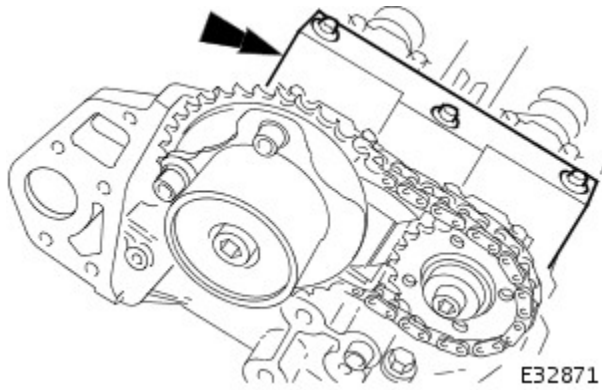

24. Loosen the bolt which secures the sprocket to the camshaft.

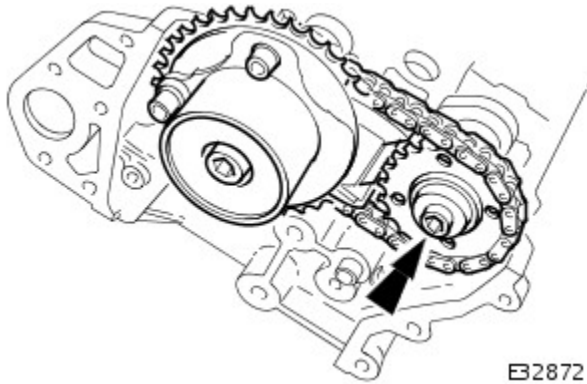

25. Loosen the bolt which secures the VVT unit to the camshaft.

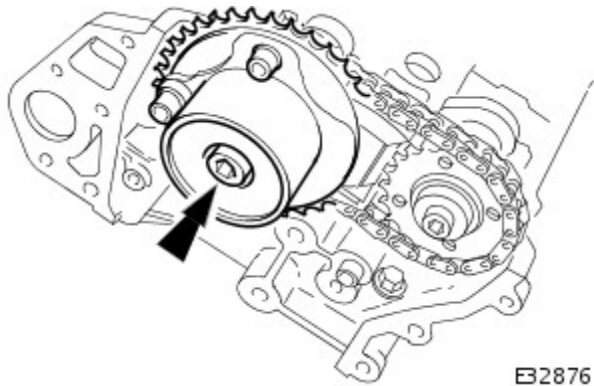

26. Remove the primary chain tensioner bolts.

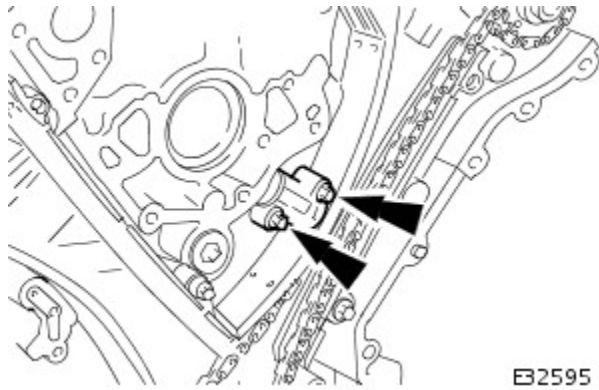

E32595

**27.** Remove the tensioner assembly.

1. Remove the tensioner.
2. Remove the tensioner back-plate.

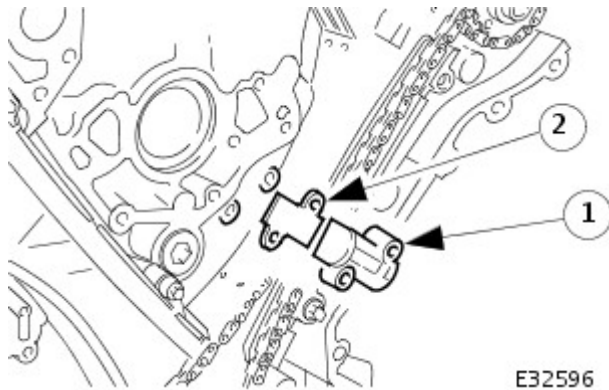

E32596

**28.** Remove the chain tensioner blade.

1. Remove the pivot bolt which secures the tensioner blade.
2. Remove the tensioner blade.

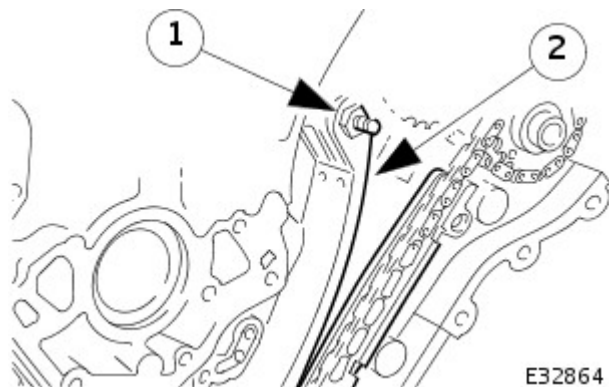

E32864

**29.** Reposition the VVT unit and exhaust camshaft sprocket forward along the camshaft bosses and remove the chain from the VVT unit and from the crankshaft sprocket.

**30.** Note the orientation of the sprockets relative to each other (half a tooth out of line).

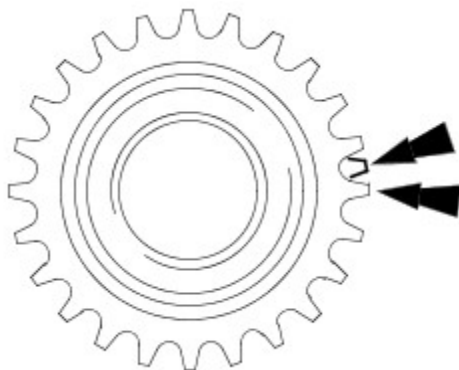

E32912

**31.** Clean and inspect all relevant components.

## Installation

1. Fit the chain tensioning tool 303 - 532 to the exhaust camshaft

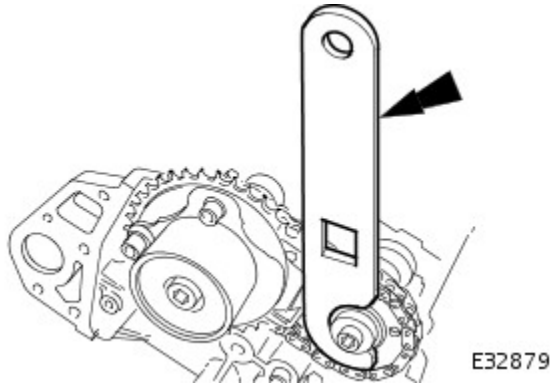

sprocket, B-Bank.

- Reposition the sprocket (and the VVT unit) for the most advantageous position for use of the tool.
- Remove the tool.

2. Refit the primary timing chain, B-Bank.

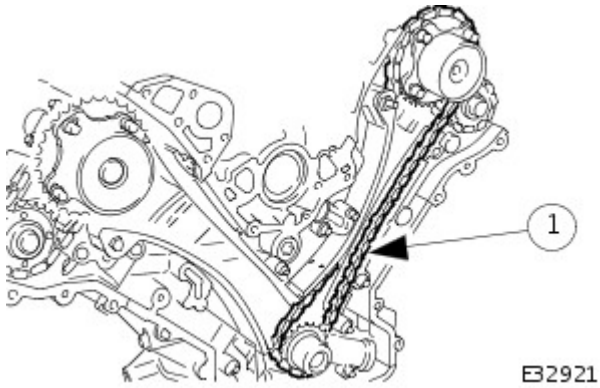

1. Fit the primary chain over the crankshaft sprocket and the VVT unit sprocket. There must be no slack on the drive side of the primary chain and the VVT unit must not be rotated on the camshaft.

- Slide the VVT and exhaust sprocket fully rearwards onto the respective camshafts.

3. Fit the primary chain tensioner blade.

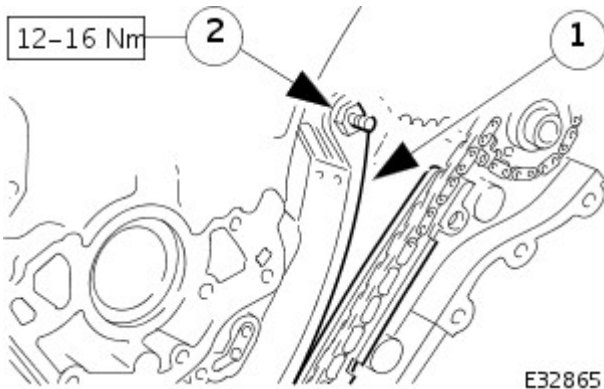

1. Position the tensioner blade to the cylinder block.

2. Fit the retaining / pivot bolt and tighten it to 12 - 16 Nm.

4. Refit the primary chain tensioner assembly. Refer to Operation 12.65.55 in this Section.

- Use a wedge 303 - 533 (or two if required) between the primary chain tensioner and tensioner blade, to take up the slack in the chain.

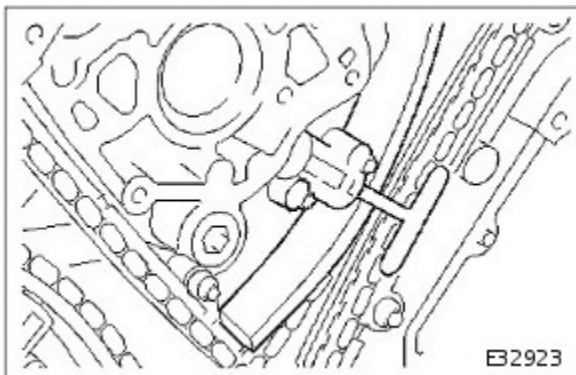

5. Tighten the exhaust camshaft sprocket securing bolt.

1. Fit the chain tensioner tool 303 - 532 to the sprocket holes.

1. Apply force to the tool in an anti-clockwise direction to tension the chain on its drive side.

2. Whilst applying the opposing force to the sprocket

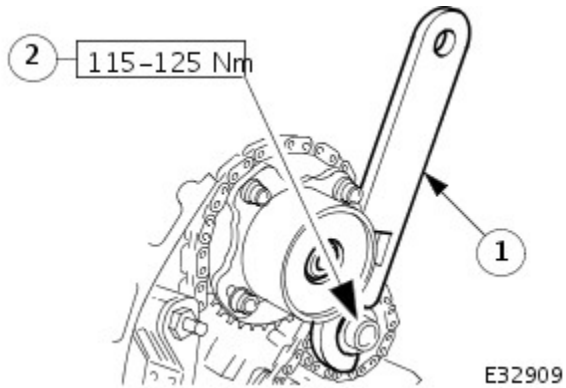

and chain, tighten the sprocket securing bolt to 115 - 125 Nm.

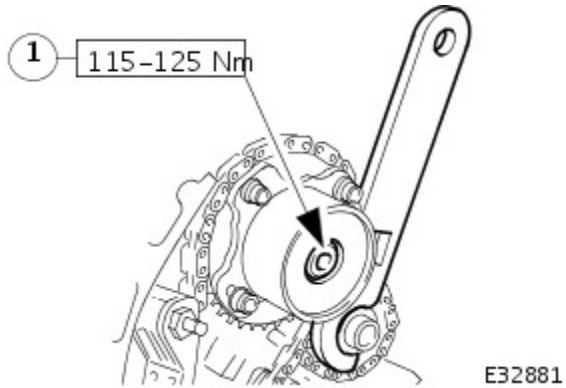

6. Tighten the VVT unit securing bolt.

1. Whilst still applying the opposing force to the sprocket and chain (using 303 - 532), check that the wedges are still in place, tighten the VVT unit securing bolt to 115 - 125 Nm.

- Remove the chain tensioning tool and the wedge(s).

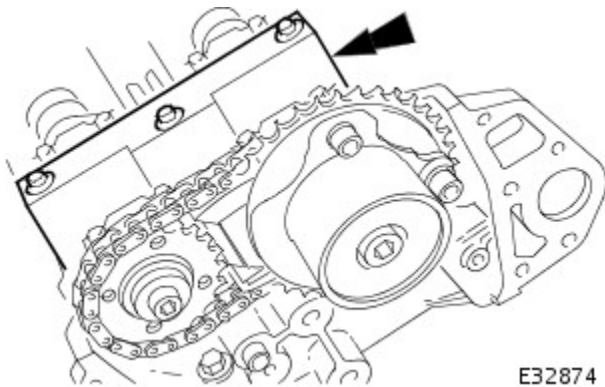

7. Remove the camshaft locking tool 303 - 530 and transfer it to the A-Bank camshafts, aligning the shafts slightly as necessary.

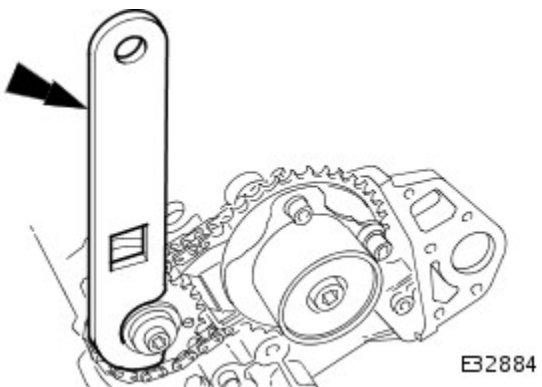

8. Fit the chain tensioning tool 303 - 532 to the exhaust camshaft sprocket, A-Bank.

- Reposition the sprocket (and the VVT unit) for the most advantageous position for use of the tool.
- Remove the tool.

9. Refit the primary timing chain, A-Bank.

1. Fit the primary chain over the crankshaft sprocket and the VVT unit sprocket. There must be no slack on the drive side of the primary chain and the VVT unit must not be rotated on the camshaft.



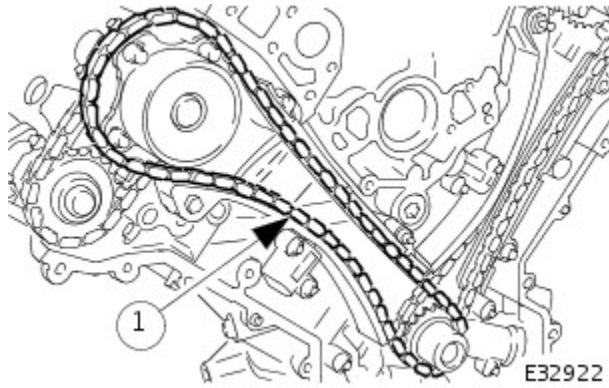

**10.** Fit the primary chain tensioner blade.

1. Position the tensioner blade to the cylinder block.
2. Fit the retaining / pivot bolt and tighten it to 12 - 16 Nm.

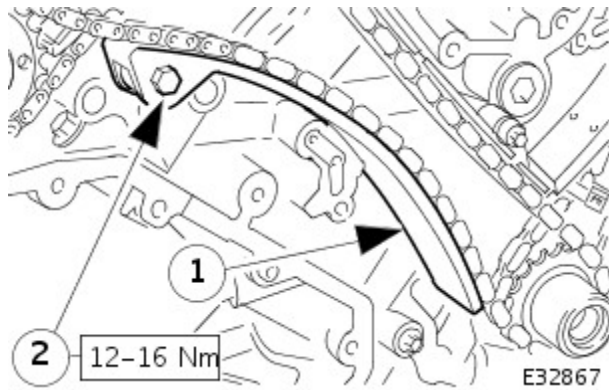

**11.** Refit the primary chain tensioner assembly. Refer to Operation 12.65.54 in this Section.

- Use a wedge 303 - 533 (or two if required) between the primary chain tensioner and tensioner blade, to take up the slack in the chain.

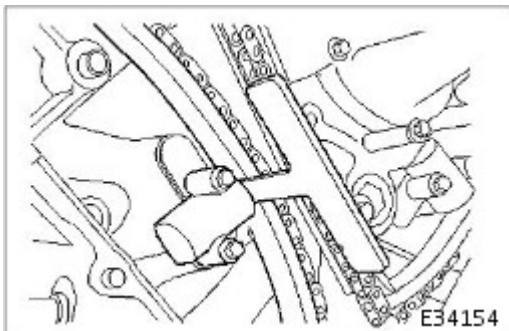

**12.** Tighten the exhaust camshaft sprocket securing bolt.

1. Fit the chain tensioner tool 303 - 532 to the sprocket holes.
  1. Apply force to the tool in an anti-clockwise direction to tension the chain on its drive side.
2. Whilst applying the opposing force to the sprocket and chain, tighten the sprocket securing bolt to 115 - 125 Nm.

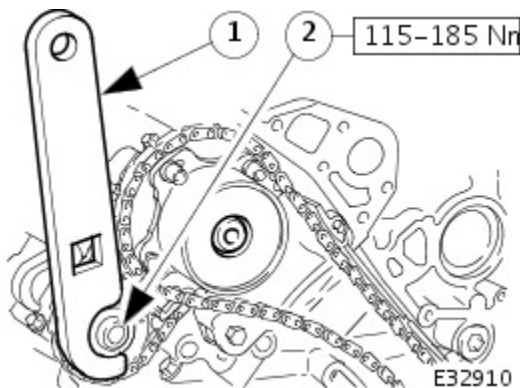

**13.** Tighten the VVT unit securing bolt.

1. Whilst still applying the opposing force to the sprocket and chain (using 303 - 532), check that the wedges are still in place, tighten the VVT unit securing bolt to 115 - 125 Nm.

- Remove the chain tensioning tool and the wedge(s).

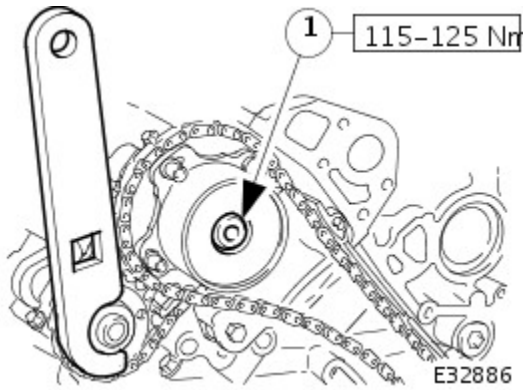

14. Remove the camshaft locking tool 303 - 530.
15. Raise the vehicle on the ramp.
16. Remove the crankshaft setting tool 303 - 531.
17. Refit the crankshaft position sensor.

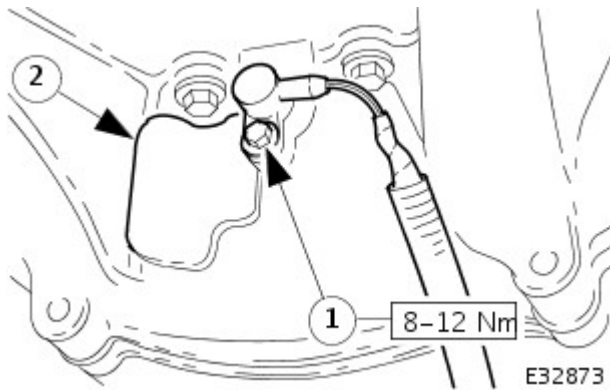

1. Fit the sensor to the flywheel housing and fit the securing bolt. Tighten to 8 - 12 Nm.
2. Refit the access grommet to the housing.

18. Lower the ramp.
19. Fit new seals to the VVT bush carrier, A-Bank.

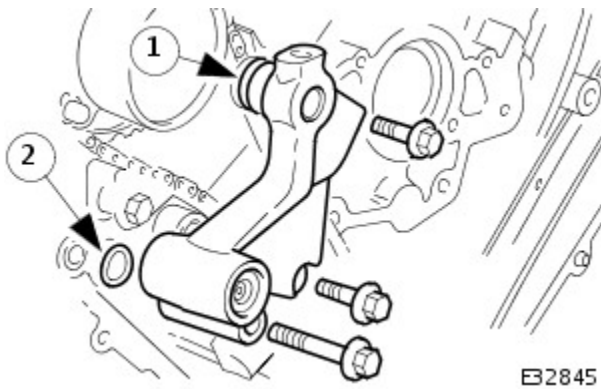

1. Fit the new sealing ring (scarf jointed) to the carrier bush groove.
2. Fit a new O-ring to the carrier oil-way.

20. NOTE: Lubricate the seal (scarf jointed) and the bush.

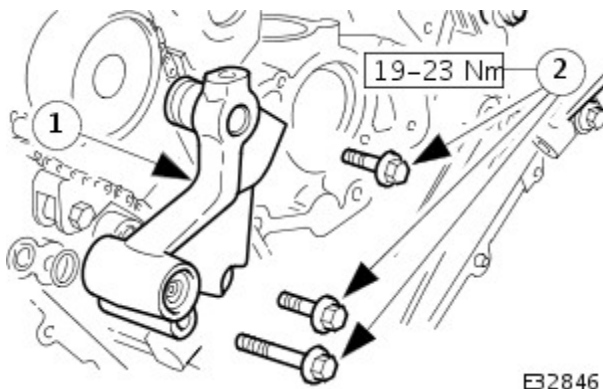

Fit the VVT bush carrier to the cylinder block.

1. Fit the bush carrier assembly.
  1. Check that the seals are in place and that the ring dowels are engaged squarely. Fully locate the assembly as much as possible by hand pressure.
2. Fit the three securing bolts. Tighten to 19 - 23 Nm.

21. Fit new seals to the VVT bush carrier, B-Bank.

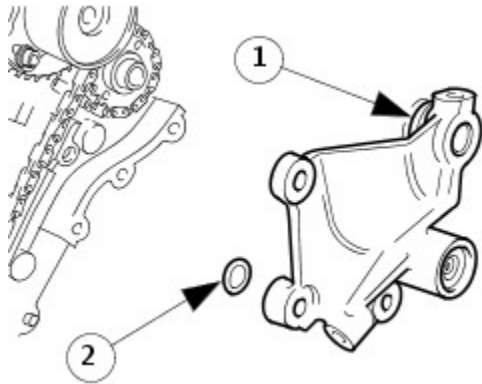

E32842

1. Fit the new sealing ring (scarf jointed) to the carrier bush groove.
2. Fit a new O-ring to the carrier oil-way.

**22. NOTE:** Lubricate the seal (scarf jointed) and the bush.

Fit the VVT bush carrier to the cylinder block.

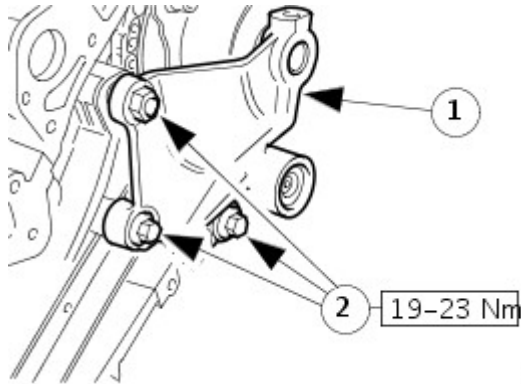

E32843

1. Fit the bush carrier assembly.
  1. Check that the seals are in place and that the ring dowels are engaged squarely. Fully locate the assembly as much as possible by hand pressure.
2. Fit the two securing bolts and one nut. Tighten to 19 - 23 Nm.

**23.** Refit the Timing Cover. Refer to Operation 12.65.01 in this Section.

**24.** Move the engine compartment cover from the service position and connect the gas struts.

**25.** Remove the paint protection sheets and close the cover.

**26.** Connect the battery and fit the battery cover.

- Refer to the Battery Reconnection Procedure 86.15.15.