

Heating and Ventilation

Schematic Diagram

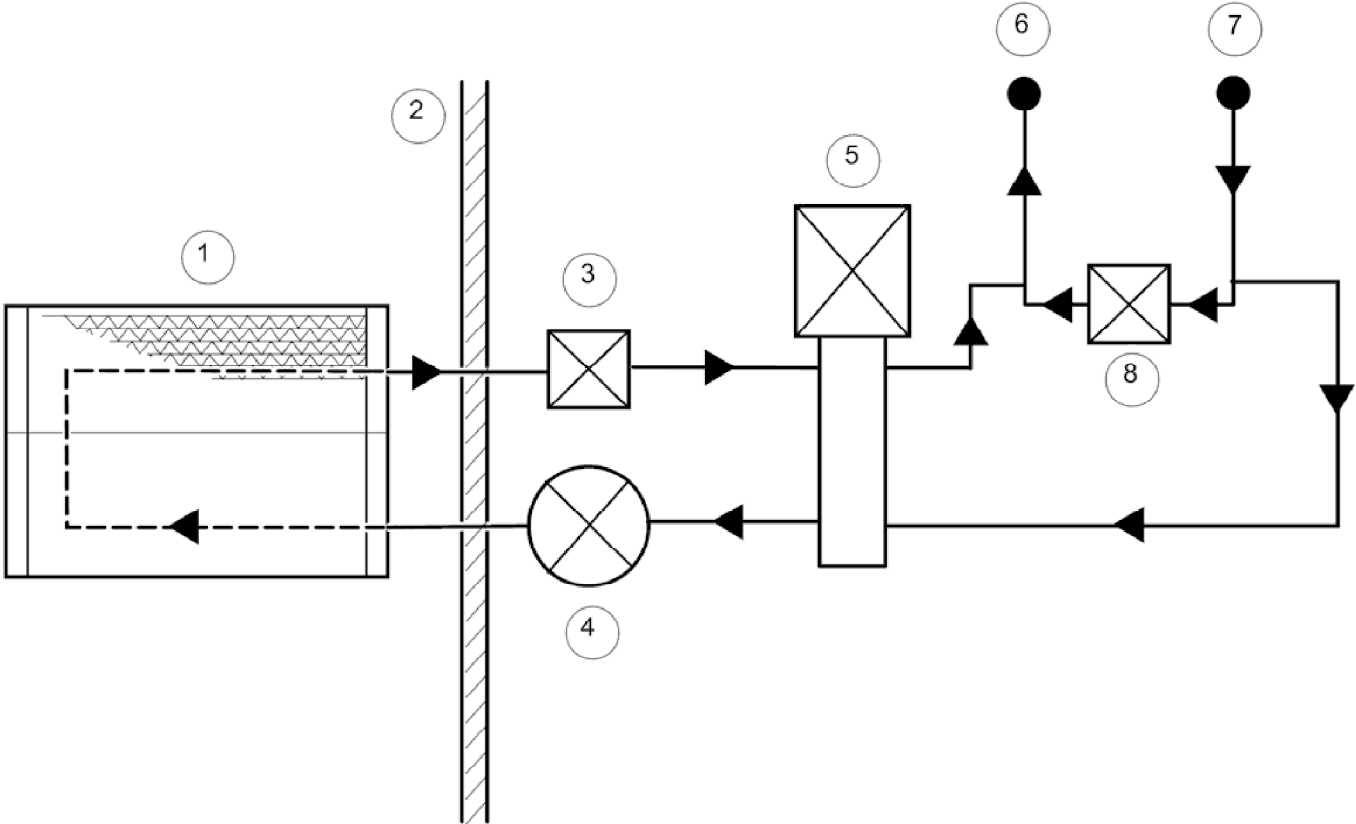

E34321

Parts List

Item	Description
1	Heater matrix
2	Firewall
3	Non return valve
4	Water pump
5	Water valve
6	Return to engine
7	Feed from engine
8	Non return valve (heater bypass)

2001 XJ RANGE - Heating and Ventilation - 412-02

Heater System Components

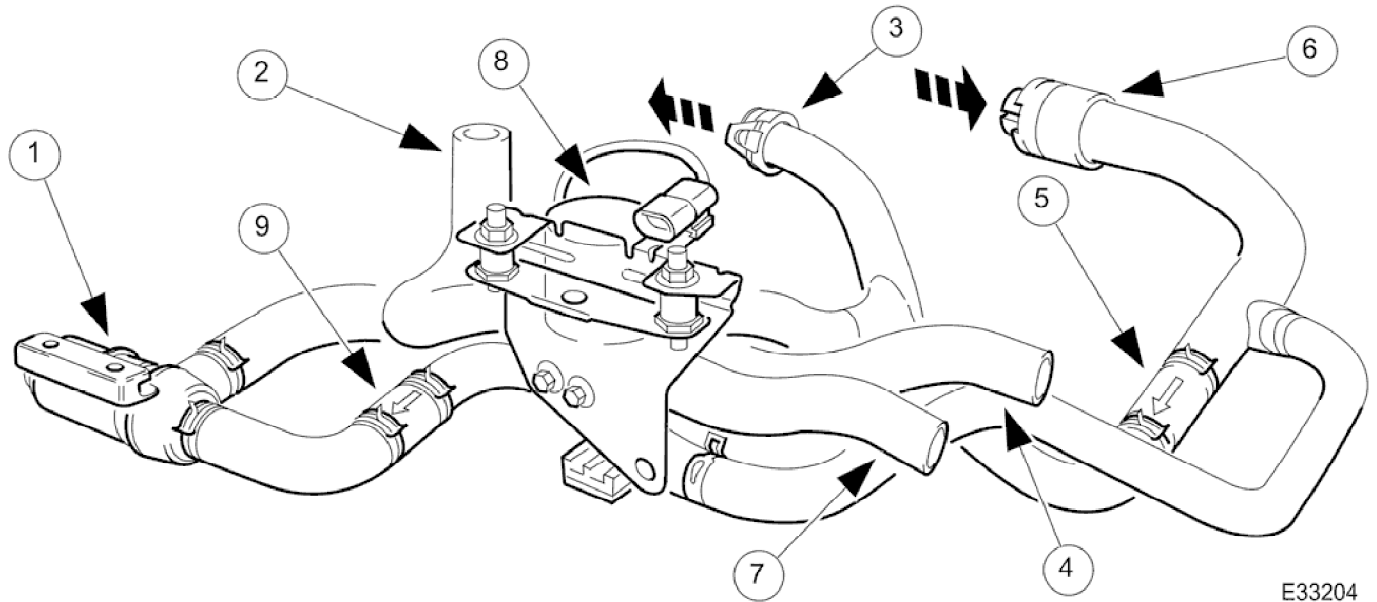

Parts List

Item	Description
1	Assembly pump - water
2	Hose - from header tank
3	Hose / connector - return to engine
4	Hose - heater feed to matrix
5	Valve - non return (by-pass)
6	Hose / connector - feed from engine
7	Hose - heater return from matrix
8	Assembly valve - water
9	Valve - non return

The heater circuit 'scavenges' coolant from the engine cooling system by means of an electric water pump. The water pump has a protection circuit to inhibit operation when the coolant temperature is $<16^{\circ}\text{C}$; this is to prevent possible damage to the impeller due to the presence of coolant borne ice particles. Coolant is drawn from the engine system through the water valve inlet port into the heater matrix. The coolant passes through the bottom section of the heater matrix from left to right filling the end tank of the matrix before returning through the top half of the matrix and through the outlet ports of the water valve and back into the engine cooling system.

Non return valves are located in the heater bypass hose and the hose between the water pump and valve. These valves are required to prevent coolant flowing in the wrong direction at low engine speeds and restrict convected flow through the heater after the engine is switched off.

When the exterior ambient temperature is $> 0^{\circ}\text{C}$ the refrigeration system automatically operates cooling and dehumidifying incoming air before it is re-heated by the heater matrix.

2001 XJ RANGE - Heating and Ventilation - 412-02

Water Valve Assembly

Location

The water valve assembly is located above the water pump, in the engine compartment and is secured to the firewall by a bracket. The valve operates by means of an electrical solenoid which oscillates the valve stem between the inlet and outlet ports.

When in automatic mode, the water valve duty cycle is influenced by the following inputs to the A/CCM:

- Outlet air temperature
- 'Air off' heater matrix temperature
- External ambient
- Coolant temperature
- Engine speed (valve closed with the engine not running)
- Demand (set) temperature
- In-car temperature sensor
- Solar sensor

Re-heating of the refrigerated air is controlled by the time that the water valve is open (i.e. not energised) over a six second interval. The duty cycle of the water valve, the time open / time closed, is controlled by the A/CCM.

Maximum heating demand will cause the water valve to be fully open (not energised) to allow maximum coolant flow through the heater matrix.

At Maximum cooling, the water valve will be fully closed (energised) to prevent hot (engine temperature) coolant entering the heater circuit; the pump however will continue to circulate coolant through both the heater matrix and water valve bypass.

The water valve defaults open when the ignition is OFF.

Under engine stall conditions, when ignition is ON, the water valve will be open.

Water Pump Assembly

Located in the same area as the water valve, the water pump continually circulates coolant through the heater matrix except when the conditions below apply:

- The engine coolant is below 16 °C.
- The ignition is OFF.
- Under engine stall conditions, when ignition is ON.
- Control panel OFF

Non return valves

The heater bypass hose has a non-return valve, located between the engine feed and return hoses. The valve prevents the water pump from recirculating coolant from the heater at low engine speeds.

The flow indicator arrow embossed on the valve body **MUST** point towards the coolant header tank.



CAUTION:

Coolant flow will be compromised if either valve is fitted incorrectly. Observe the correct direction.

A second non-return valve is located between the water pump and water valve. This valve prevents hot coolant from flowing into the heater with the engine switched off. The flow indicator arrow **MUST** point towards the water pump.

2001 XJ RANGE - Heating and Ventilation - 412-02

Heater feed and return hoses

The heater feed and return hoses are connected to the engine feed and return hoses by 'Quick-Fit' connection unions. The feed hose has a Norma R20 connector and the return hose a Norma push and seal connector. The coolant system bleed joints have Cobra clamps. All remaining hose connections have spring band hose clamps.

The engine feed hose is connected to the engine bypass housing and the engine return hose is connected to the engine water pump.

Clamp Identification

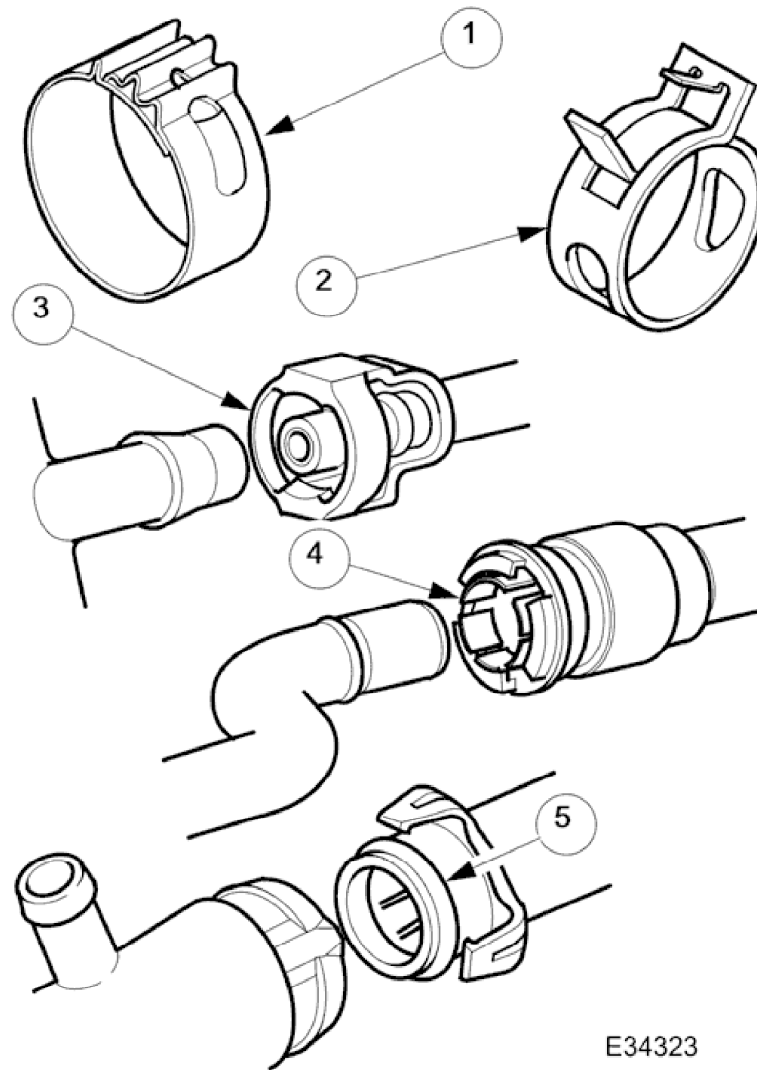

E34323

Parts List

Item	Description
1	Cobra
2	Spring band
3	Quick-fit
4	Norma push and seal 'R' type
5	Norma push and seal 15