

Special Tool 307-378 –
W5A580 Automatic Transmission –
Replacing Input & Output Shaft Seals

MODEL 1998 MY-ON
XJR

VIN
812256-ON

Issue:

Mandatory Service Tool 307-378 has been introduced for the W5A580 automatic transmission used in XJR (supercharged) vehicles.

Action:

To install input and output shafts seals on the W5A580 automatic transmission, use tool 307-378 (Illustration 1) as described on the following page.

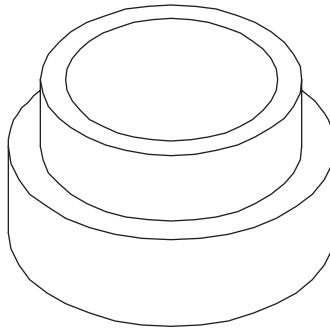
SPECIAL TOOL 307-378

J.WST.149

ILLUSTRATION 1

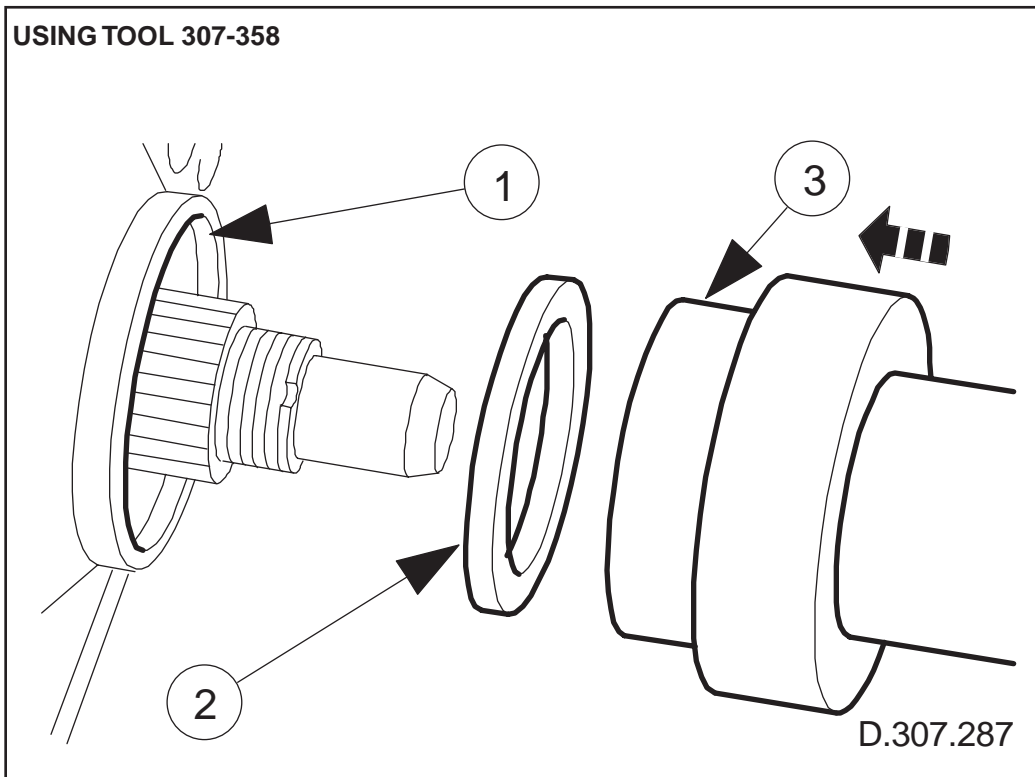

ILLUSTRATION 2

1. Lubricate the seal retaining bore in the transmission housing.
2. Lubricate the circumference of the seal.
3. Use the seal replacement tool to drive the seal evenly into the transmission housing.
4. Make sure that the seal is correctly seated in the retaining bore.

Note: Rear output-shaft seal shown.