

Transmission Fluid Drain and Refill

Special Service tools

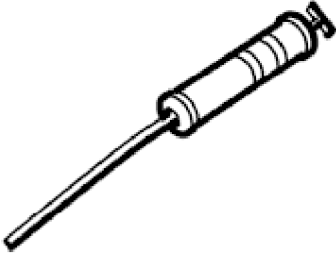

E36416

Syringe

Removal

1. Raise the vehicle for access.

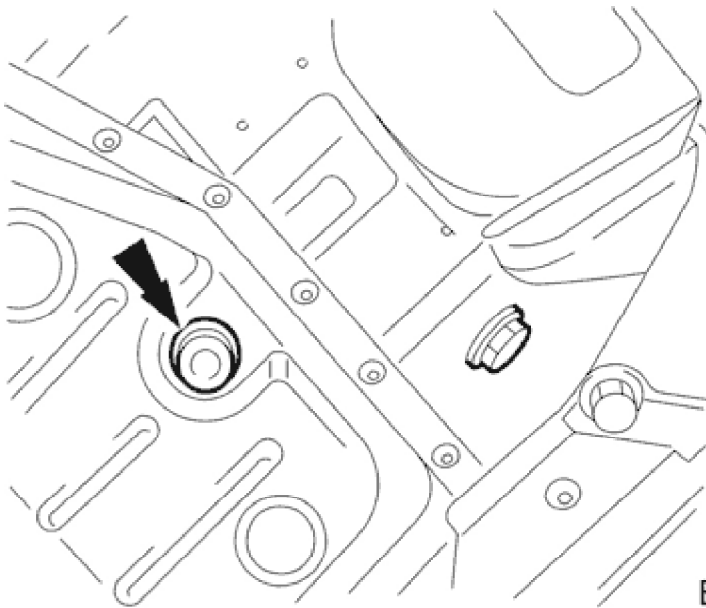

E35350

2. **NOTE:**

This procedure will not remove residual fluid from the torque converter.

Drain the transmission fluid.



WARNING:

TRANSMISSION FLUID MAY CAUSE SEVERE BURNS, ENSURE THAT ALL SAFETY PROCEDURES ARE OBSERVED AND THAT THE RECEPTACLE FOR WASTE HAS SUFFICIENT CAPACITY.

- Carefully remove the drain plug and drain the transmission fluid.

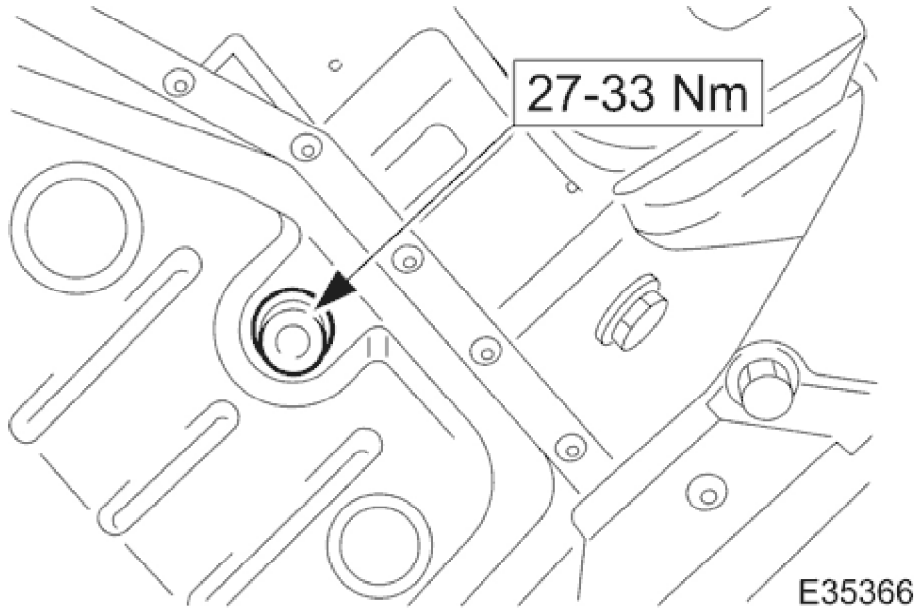

3. Refit the drain plug and tighten to the specified torque figure.
 - Use a new O-ring.

Installation

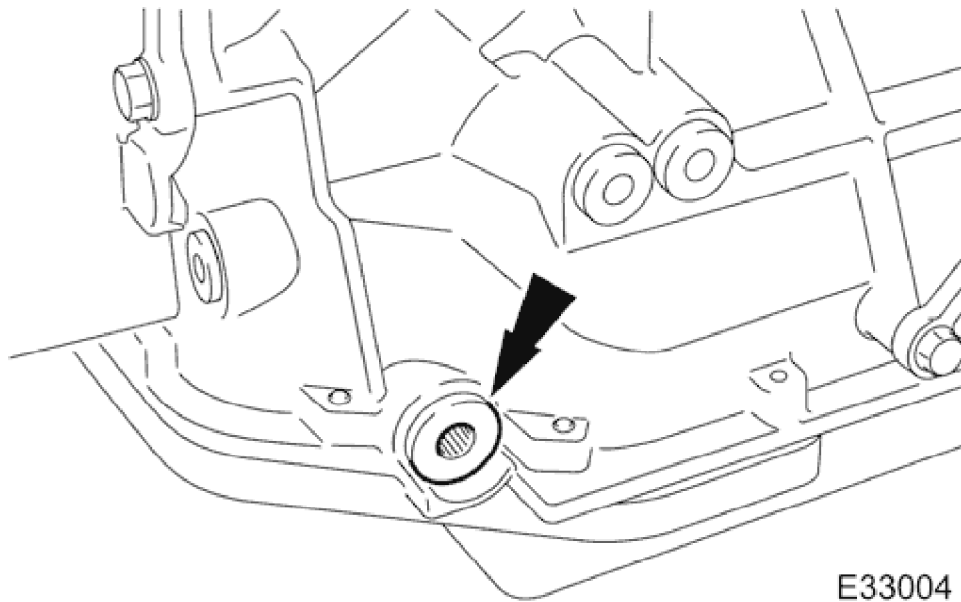

1. Remove the fluid level / filler plug.
2. Using a syringe dedicated to transmission fluid only (not used for any other type of oil or fluids), inject transmission fluid until it overflows from the plug orifice.



CAUTION:

It is essential that only the specified fluid is used.

- Wait until the flow of fluid has reduced to a trickle.

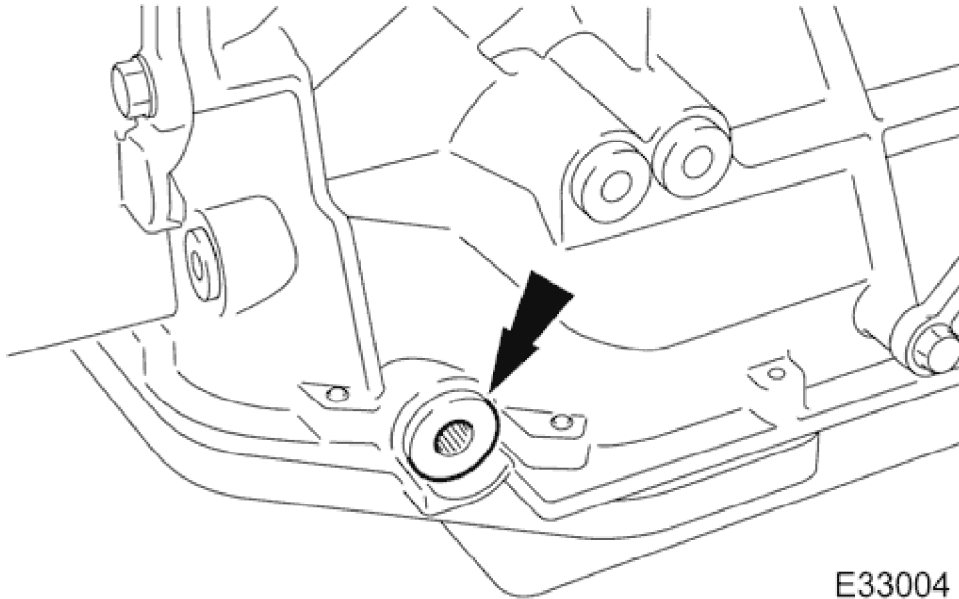

E33004

3. Fit, but do not tighten the plug.

4. Prepare PDU (at the base station).

1. Install the appropriate disk and switch ON.
2. Select the vehicle specification - ENTER.
3. From Engineering Tools select Toolbox - ENTER.
4. From Toolbox select Powertrain - ENTER.
5. Connect MPA and download cable to PDU and base station.
6. Select Datalogger - ENTER.
7. Select Transmission - ENTER.
8. Disconnect download cable.
9. Connect MPA to PDU.

5. Connect PDU (at the vehicle).

1. Connect MPA cable to the vehicle diagnostic socket - ENTER.
2. Energize the vehicle ignition - ENTER.
3. From the menu select Transmission oil temperature (TOT) - ENTER.
4. Check that the fluid temperature is $<30^{\circ}\text{C}$.

6. From above.

600 - 750



7. **NOTE:**
Ensure that the TCM is connected and functioning correctly.

Select Park and start the engine.

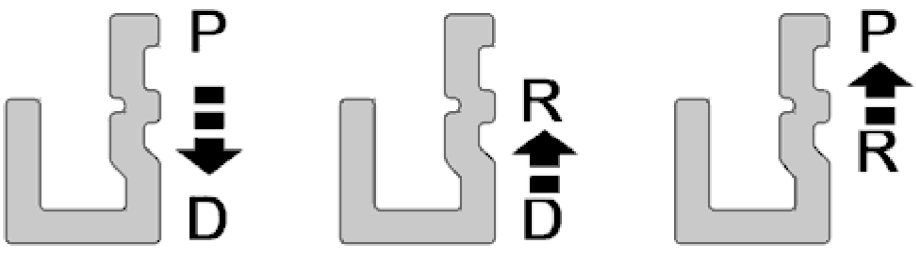

E33017

8. Cycle the gear selector.
- From P to D.
 - From D to R.
 - From R to P.

9. From below.

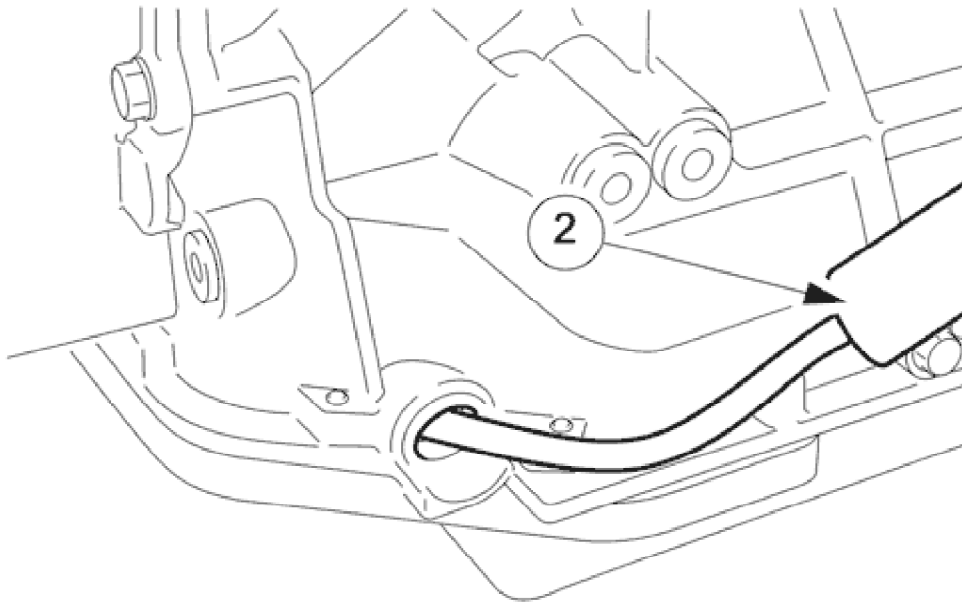
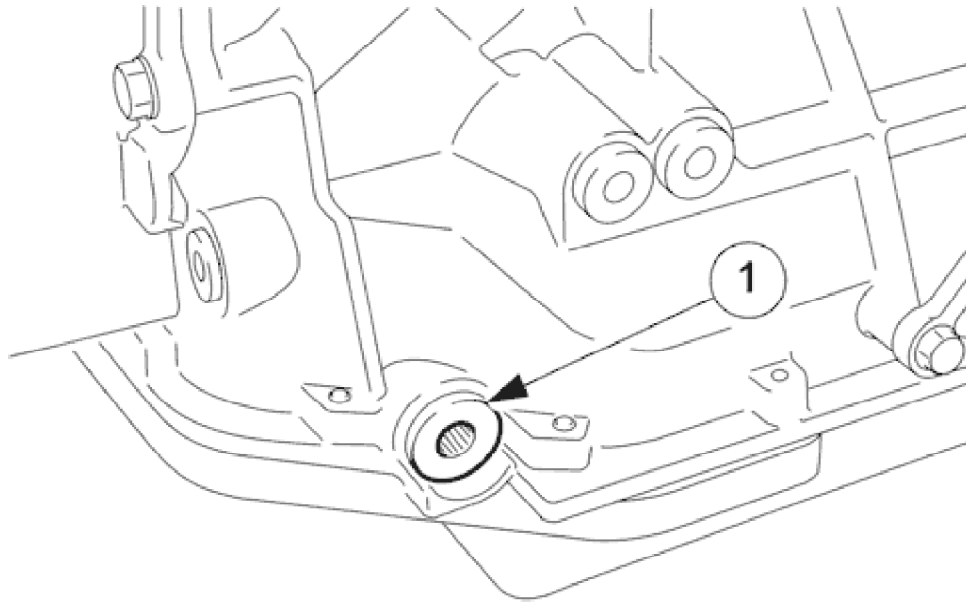

E34201

10. Adjust the transmission fluid level.
 1. Remove the filler / level plug.
 2. Inject fluid until it overflows from the plug orifice.



CAUTION:
The fluid temperature **MUST NOT** exceed 50°C.

- Wait for the flow of fluid to reduce to a trickle (for at least 1 minute).

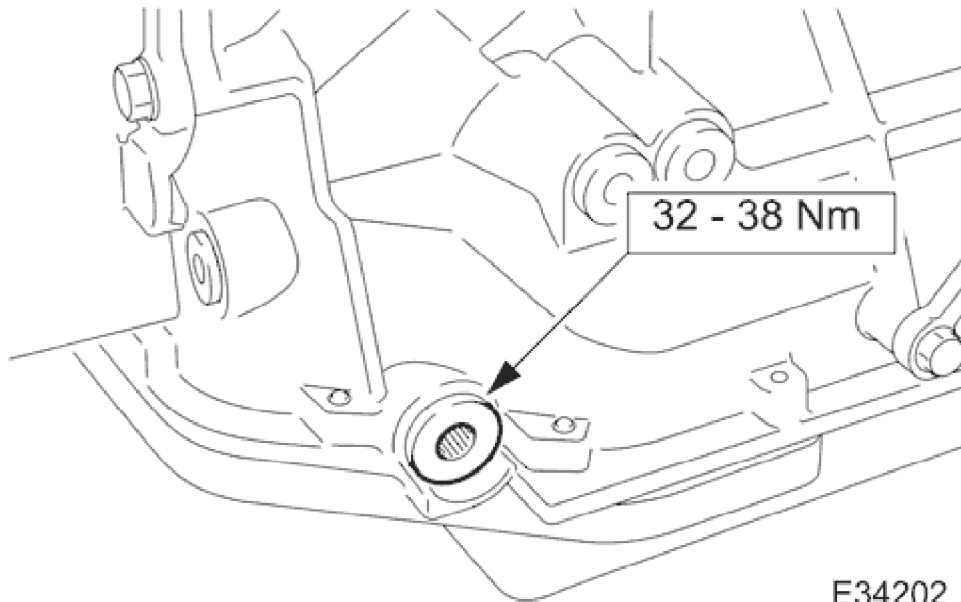

E34202

11. Refit the filler / level plug and tighten to the specified torque figure.
12. Check for leaks and remove spilt fluid.
13. Shut down and disconnect PDU.REMOVAL AND INSTALLATION