

Power Steering

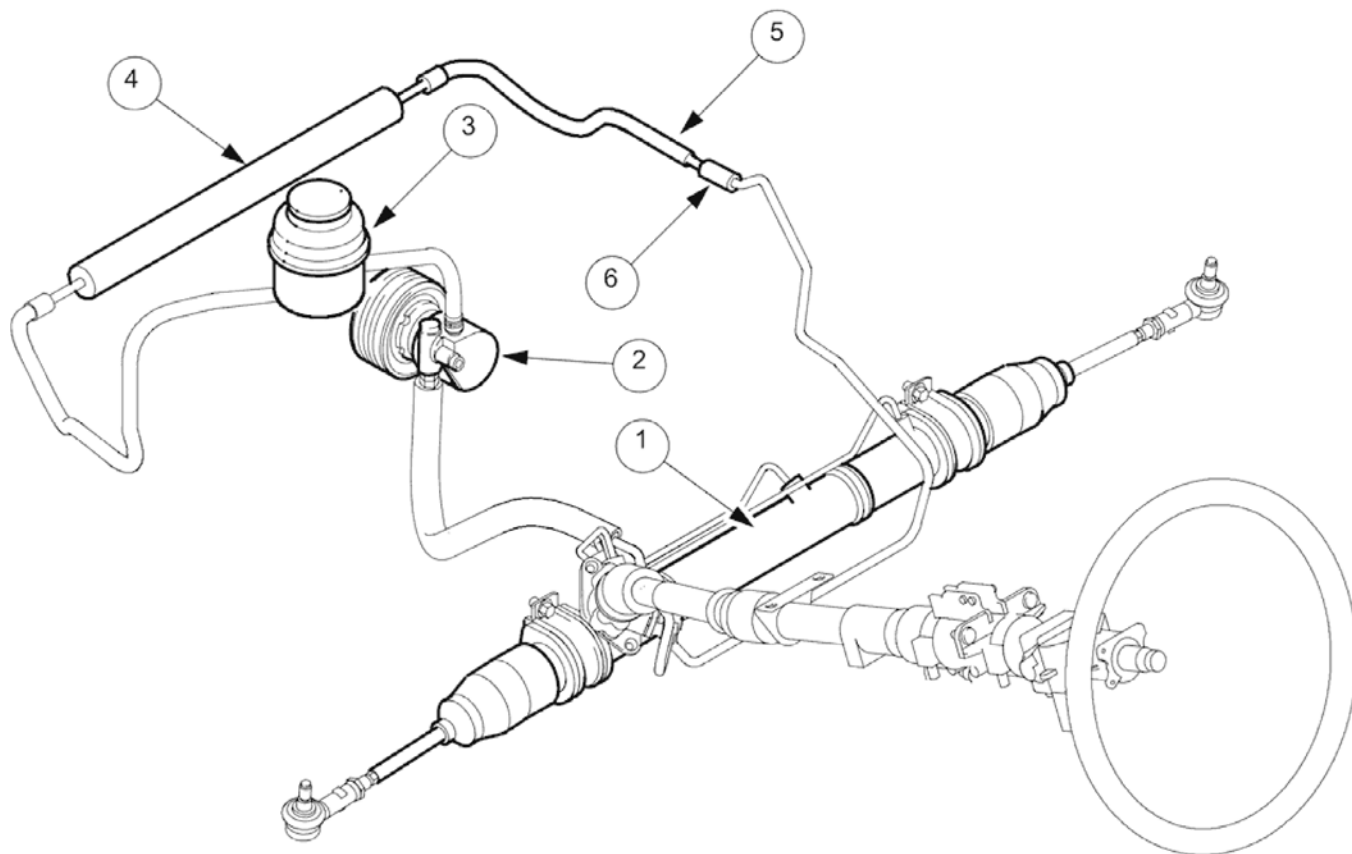

E33866

Parts List

Item	Description
1	Steering rack assembly
2	Power assisted steering pump
3	Fluid reservoir
4	Fluid cooler
5	Hoses and pipework
6	In-line quick-fit connector

The power steering system is a rack and pinion design, with an engine-driven pump providing the steering assistance. The system features variable steering assistance with vehicle speed, a variable ratio steering rack, and a hydraulic control valve which has a torsion bar arrangement giving improved center feel to the steering.

Absolute cleanliness must be observed when replenishing the fluid or dismantling any part of the system. If any major component is renewed a new fluid reservoir must be fitted. New fluid from a sealed container must be used.

Steering Rack Assembly

1998 XJ RANGE - Power Steering - 211-02

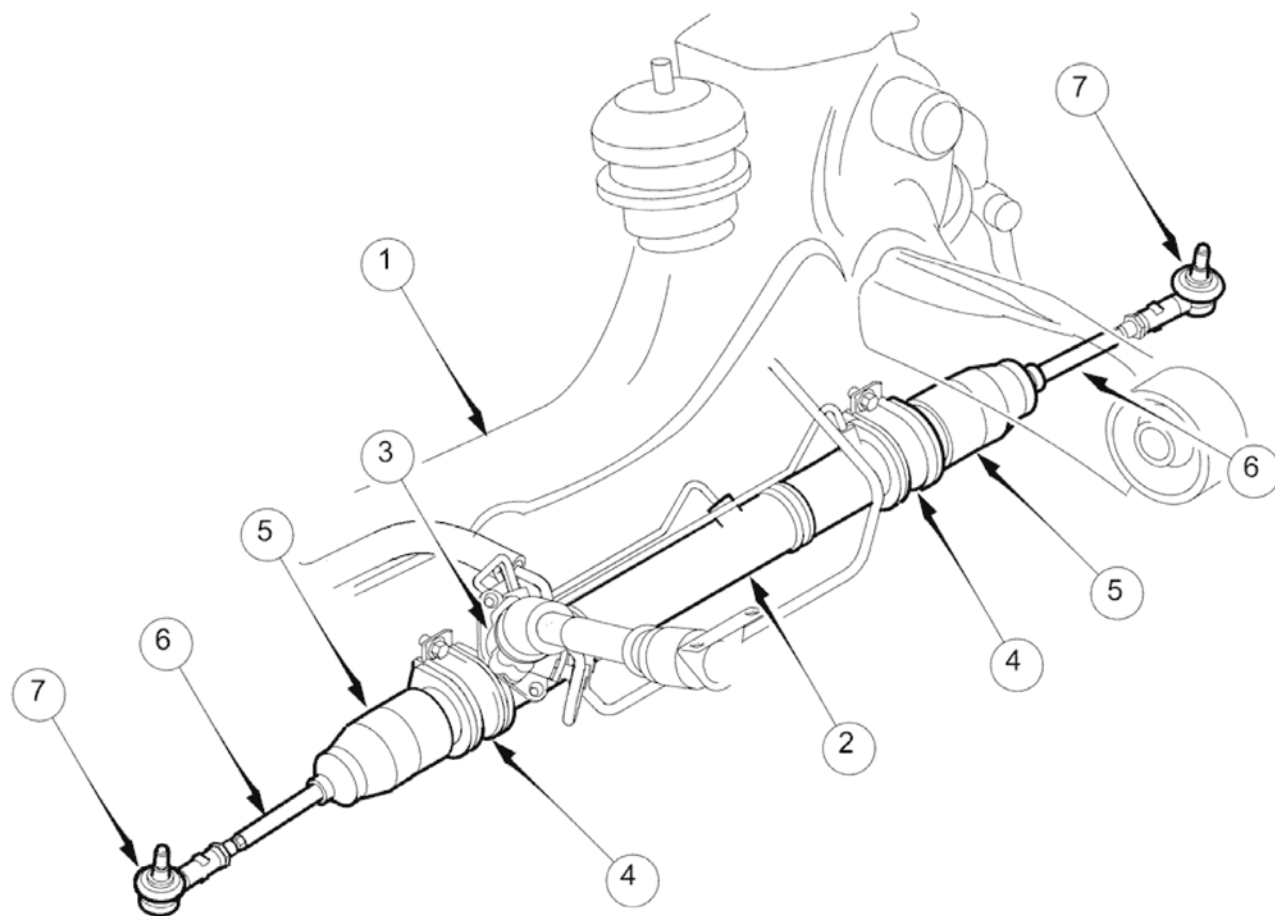

E33867

Item	Description
1	Front suspension crossbeam
2	Steering rack housing
3	Hydraulic control valve housing
4	Mounting bracket
5	Gaiter
6	Tie rod
7	Outer ball joint

The steering rack assembly:

- Is mounted on the rear face of the front suspension crossbeam by two forged mounting brackets with resilient bushes. The bushes are handed (pinion side and non-pinion side) and are orientated according to the vehicle range application.
- Converts the rotary motion of the steering wheel, via the steering gear pinion, to the lateral motion of the rack.
- Features a variable ratio steering rack with integral hydraulic power steering cylinder and piston.
- Has a hydraulic control valve with Servotronic control and positive center feel torsion bar.

The basic steering rack assembly is not serviceable. The following components are serviceable items:

- Transfer pipework.
- Servotronic valve.
- Centralizing cap.

1998 XJ RANGE - Power Steering - 211-02

- Outer ball joint.
- Rack gaiter.
- Clips and fittings.

Steering Rack Components

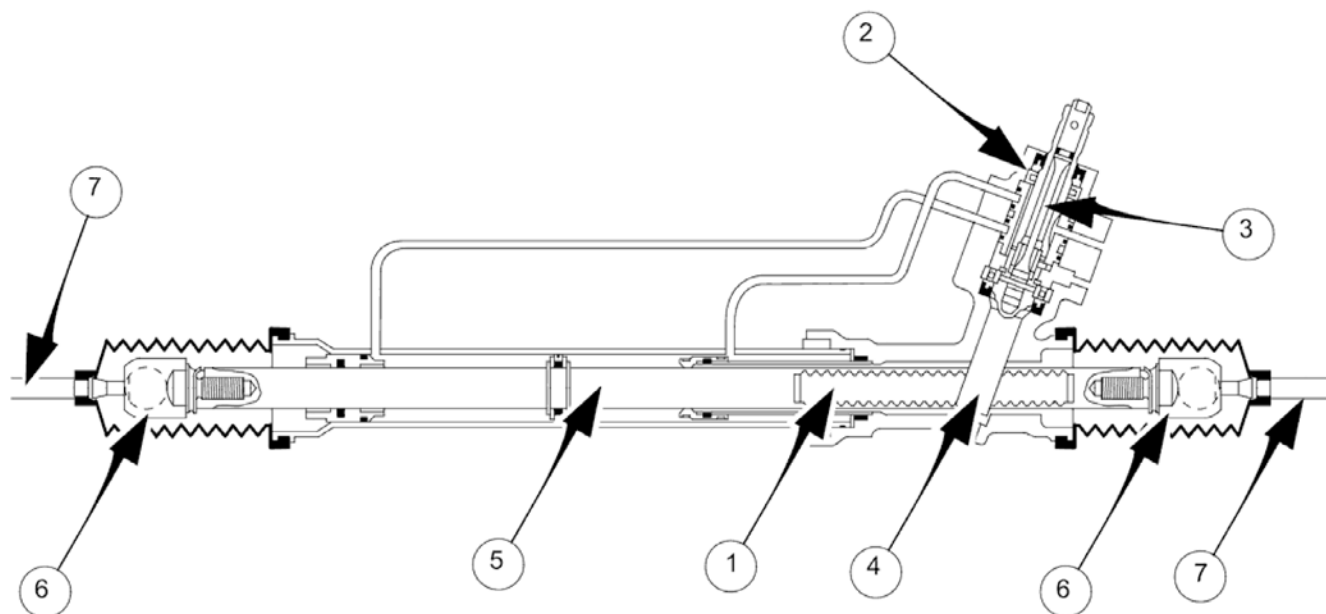

E33868

Parts List

Item	Description
1	Steering rack
2	Hydraulic control valve
3	Torsion bar
4	Pinion
5	Operating cylinder and piston
6	Inner ball joint
7	Tie rod

Variable Ratio Steering Rack

1998 XJ RANGE - Power Steering - 211-02

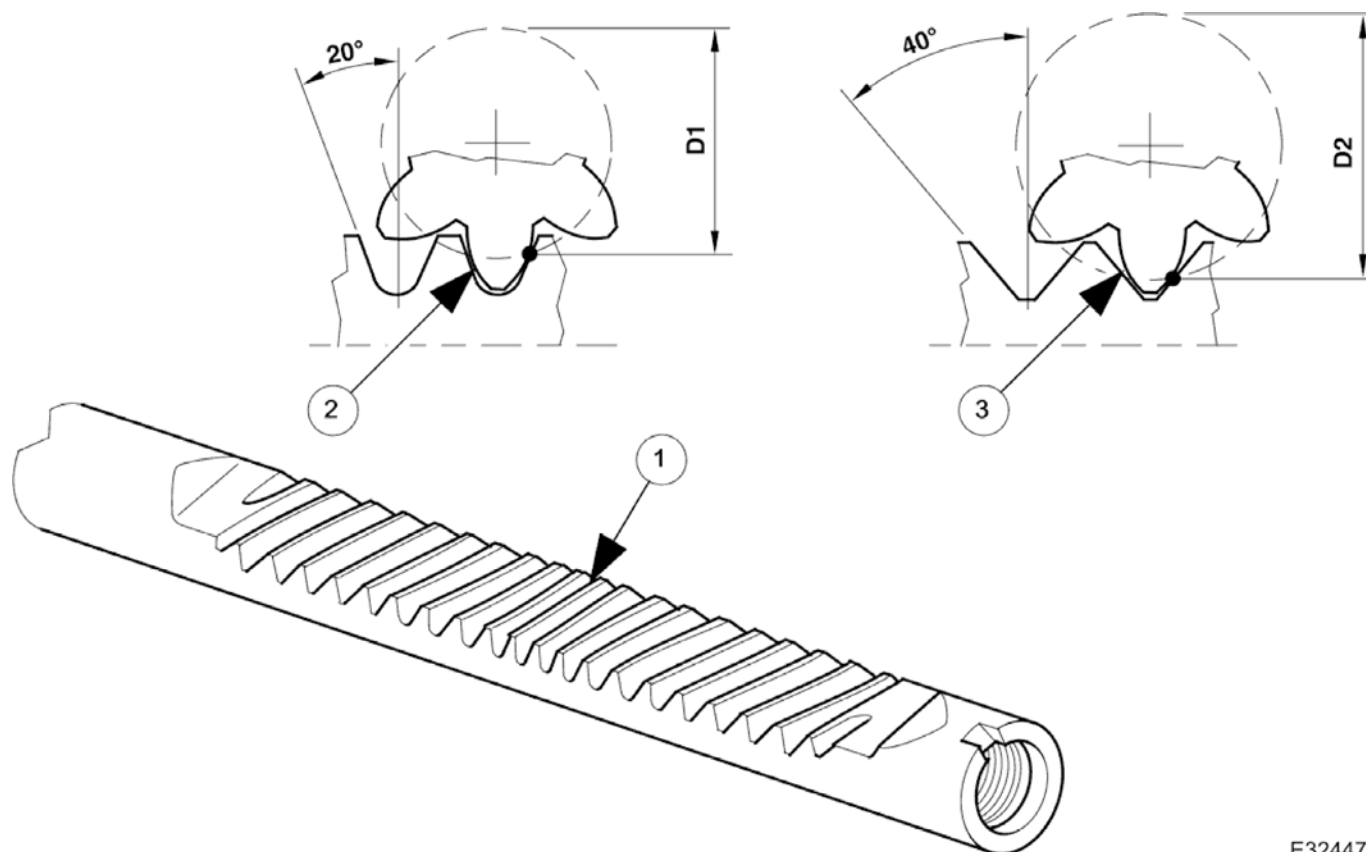

E32447

Parts List

Item	Description
1	Steering rack
2	Tooth contact angle at center of rack
3	Tooth contact angle at ends of rack

The variable ratio rack:

- Incorporates teeth of varying pitch and angle of contact, giving a variable pitch circle diameter which is a minimum at the center of the rack and a maximum at the ends.
- Reduces excessive response to on-center steering inputs during motorway driving.
- Causes the steering action to become progressively more direct as the steering wheel is turned from the center position.
- Allows a low number of turns of the steering wheel from lock to lock.

Positive Center-Feel Torsion Bar

Torsion Bar Components

1998 XJ RANGE - Power Steering - 211-02

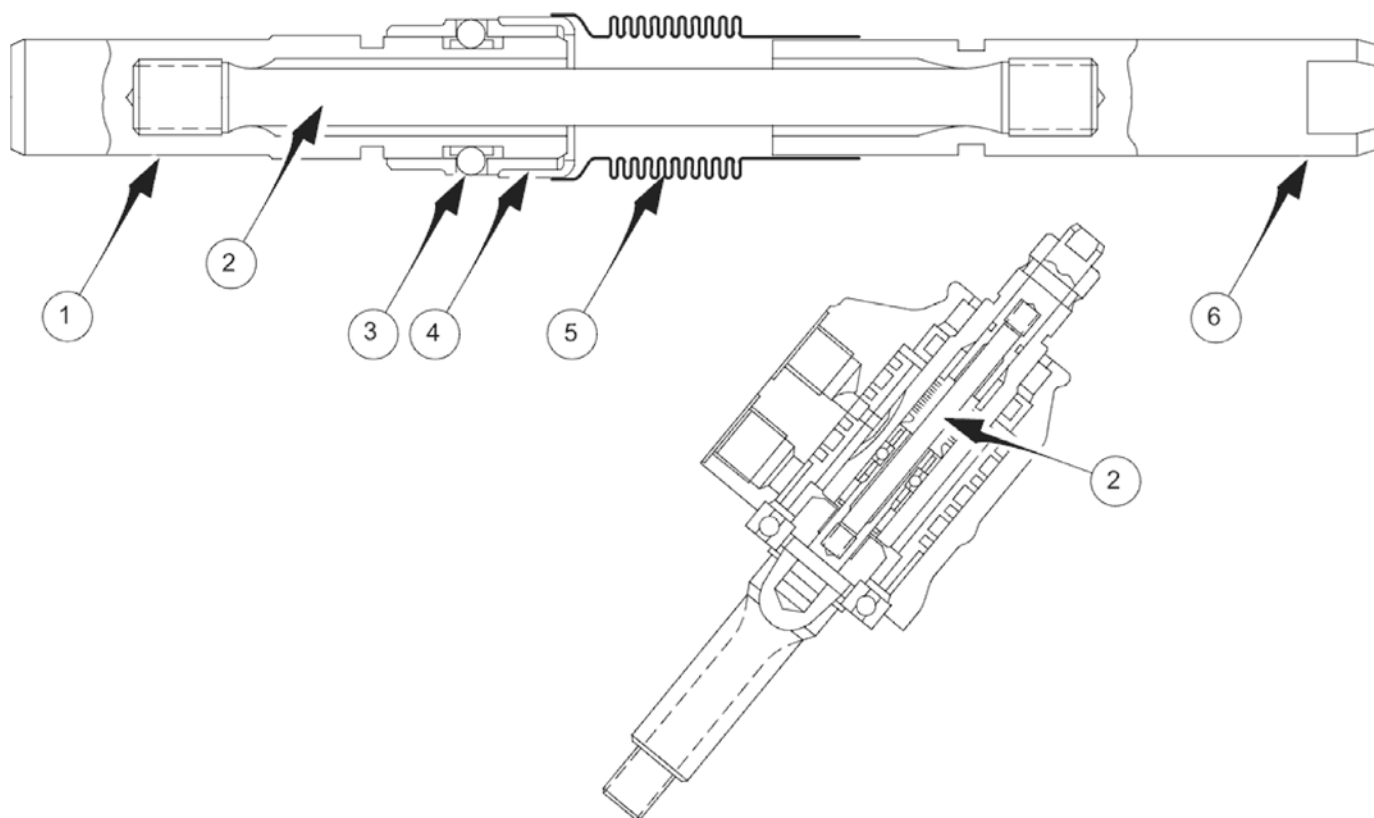

E33869

Parts List

Item	Description
1	End piece
2	Torsion bar
3	Caged ball bearings
4	Centering device
5	Bellows spring
6	Input shaft

The positive center-feel torsion bar improves the straight ahead feel of the steering in the region where very small amounts of hydraulic pressure, and hence reaction pressure, are generated.

The torsion bar assembly forms part of the hydraulic control valve assembly, and includes an axially pre-loaded metal bellows spring, which is arranged co-axially with the torsion bar. The torsion bar is positively connected between the end piece and the input shaft. One end of the bellows spring is attached to the input shaft, while the other end is attached to a centering device. The centering device has two prism-shaped recesses with caged, guided, ball bearings arranged between the recesses, and determines the zero-torsion position of the bellows spring.

On turning the steering wheel from the straight ahead position, the spring forces of the torsion bar assembly must be overcome. Initially, the bellows spring produces substantial additional torsional resistance. However, after an angular movement of approximately 0.2 degrees the torsional rigidity decreases and becomes similar to a conventional torsion bar.

Power Assisted Steering Pump

1998 XJ RANGE - Power Steering - 211-02

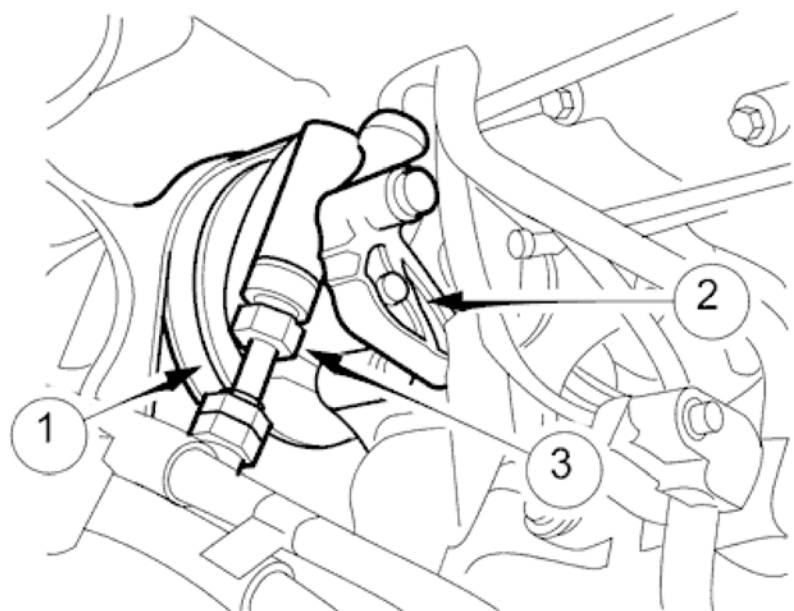

E33870

Parts List

Item	Description
1	Power assisted steering pump
2	Engine mounting bracket
3	High pressure port

The power assisted steering pump:

- Is mounted on a bracket installed on the front of the engine.
- Provides hydraulic pressure for the power steering system.
- Is of the roller vane type.
- Is belt driven from the engine crankshaft.
- Will provide 105 bar fluid pressure.

The pump is not serviceable and should be renewed as a complete assembly.

Fluid Reservoir

Reservoir and Hoses

1998 XJ RANGE - Power Steering - 211-02

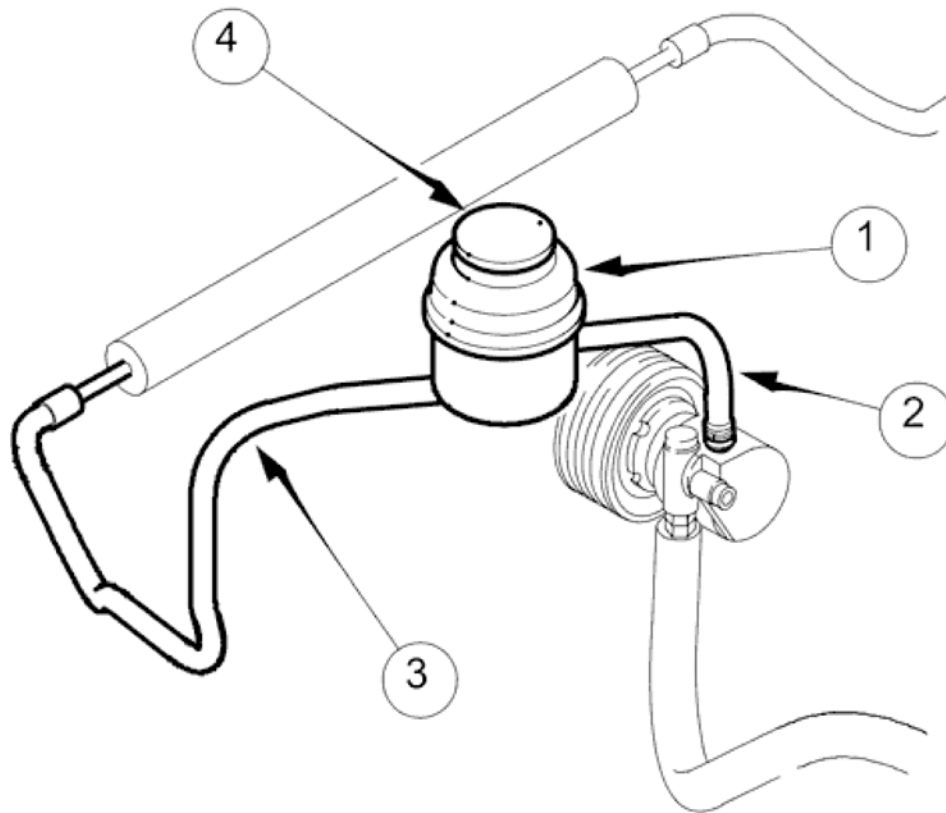

E33871

Parts List

Item	Description
1	Fluid reservoir
2	Supply line
3	Return line
4	Filler cap

The fluid reservoir:

- Is located in the engine compartment, mounted on the engine compartment fuse box bracket.
- Incorporates a 10 micron, lifetime, integral filter.
- Has a capacity of 0.4 liter.
- Has a dipstick incorporated into the filler cap for checking the fluid level.

A new reservoir must be fitted if the steering rack, pump or fluid cooler are renewed.

Fluid Cooler

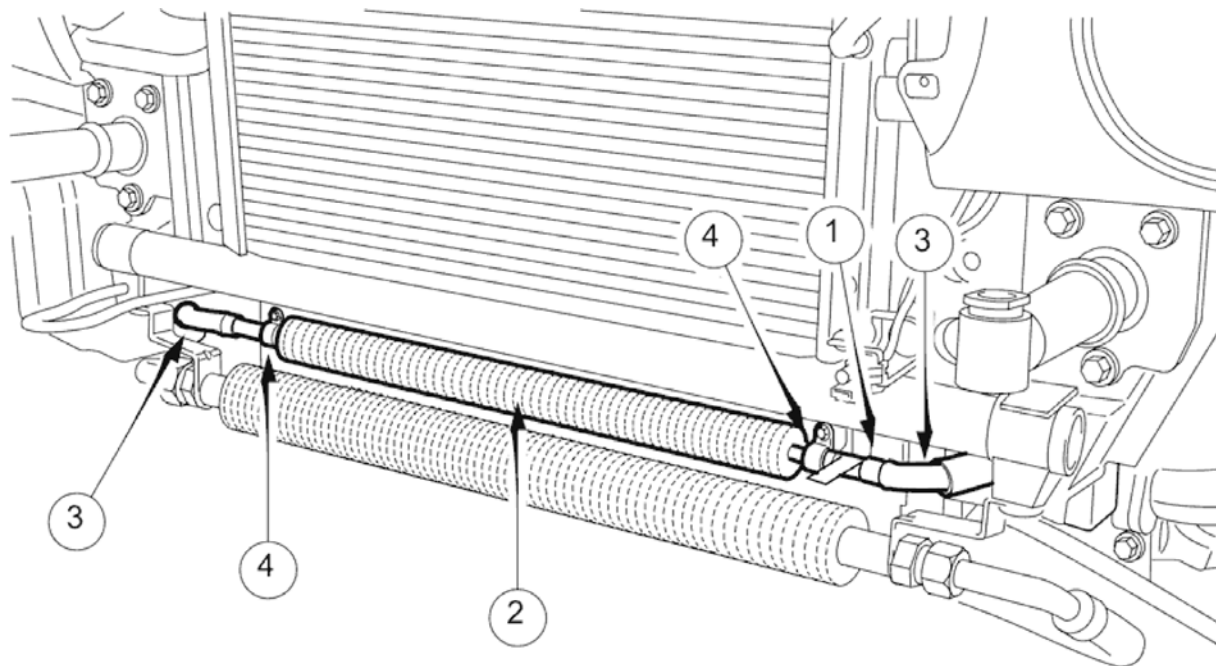

E33872

Parts List

Item	Description
1	Front body cross member
2	Fluid cooler
3	Integral hoses
4	Cooler mounting

The fluid cooler:

- Is resiliently mounted on the front body cross member.
- Cools the fluid before it is returned to the reservoir.
- Is of the wire-bound tube type.
- Has integral hoses.

Supply and Return Hoses and Pipework

The supply and return hoses and pipework deliver fluid at high pressure from the pump to the steering rack assembly. The fluid is then returned to the reservoir through the cooler tube. The high pressure supply hose contains two cable-type attenuators, one at each end, to reduce noise. The return pipe is clipped to the steering rack housing by a resilient mounting.

Latch-Plate Location

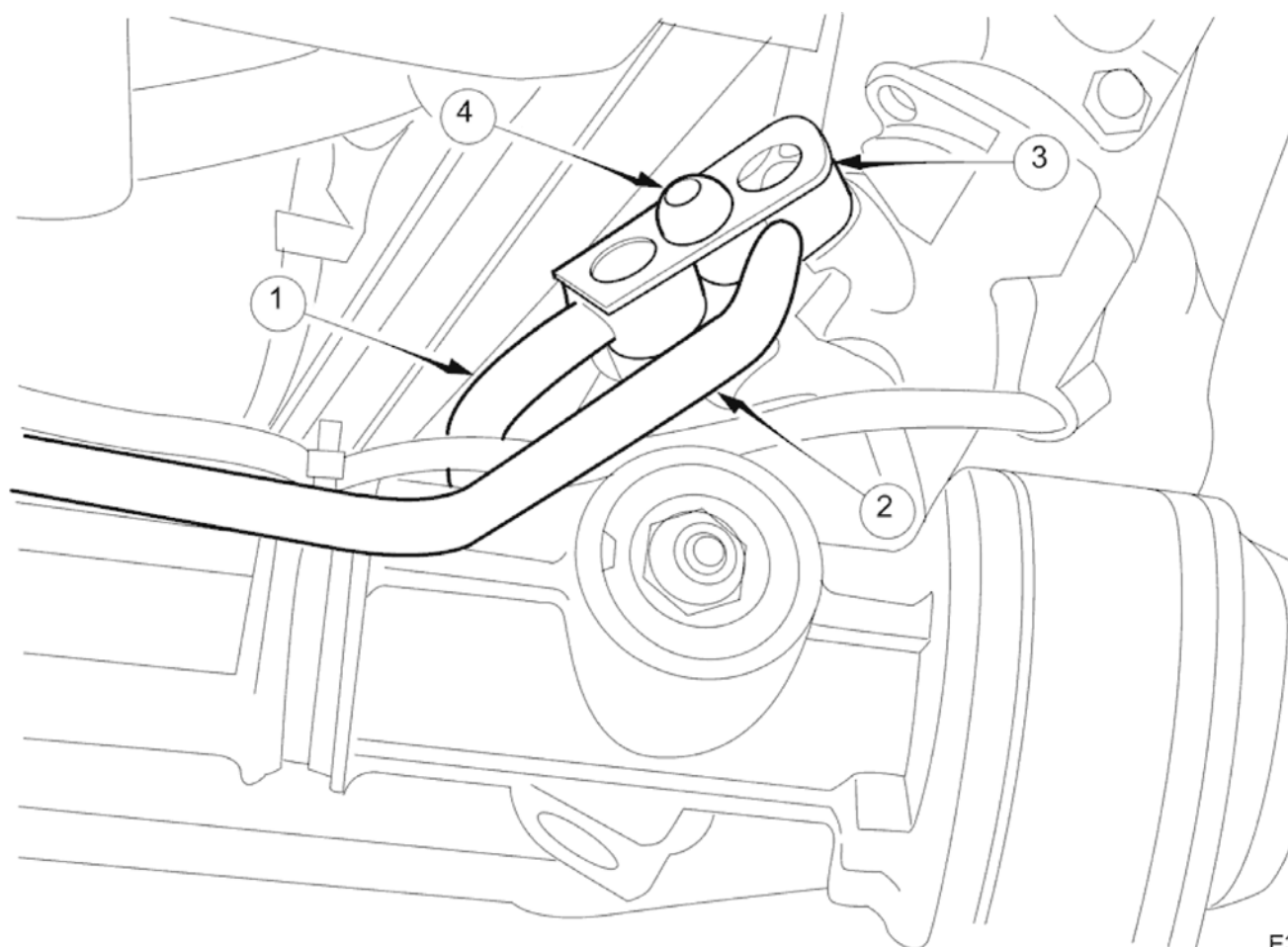

E33873

Parts List

Item	Description
1	Return pipe (RH drive)
2	Supply pipe (RH drive)
3	Latch-plate
4	Latch-plate securing screw

The supply and return pipes are secured to the hydraulic control valve housing by a latch-plate having a single fixing screw. The latch-plate is captive to the supply pipe. Each pipe has an O-ring which is a serviceable item.

In-Line Quick-Fit Connector

1998 XJ RANGE - Power Steering - 211-02

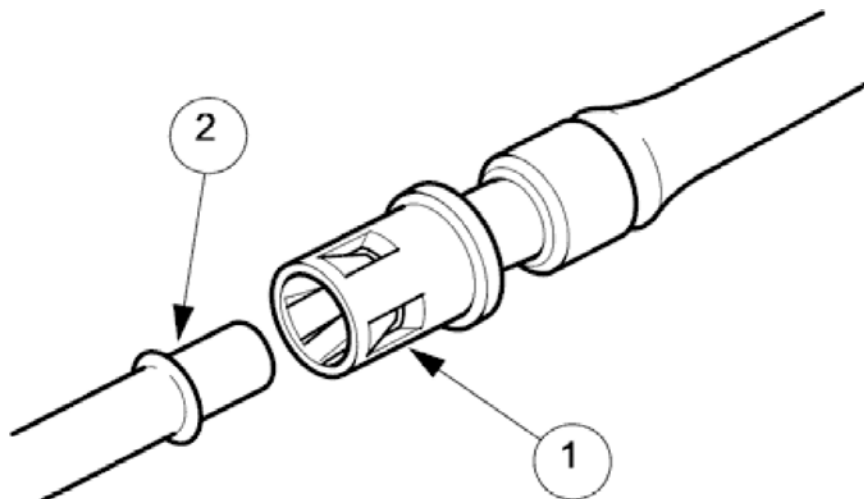

E33863

Parts List

Item	Description
1	Quick-fit connector
2	Return pipe

A quick-fit connector with double O-ring seals is incorporated in the return line and is clipped to the right-hand chassis side member. The quick-fit connector O-rings are not serviceable.

Special tool JD 182 is required to disconnect the quick-fit connector.

Hydraulic System

1998 XJ RANGE - Power Steering - 211-02

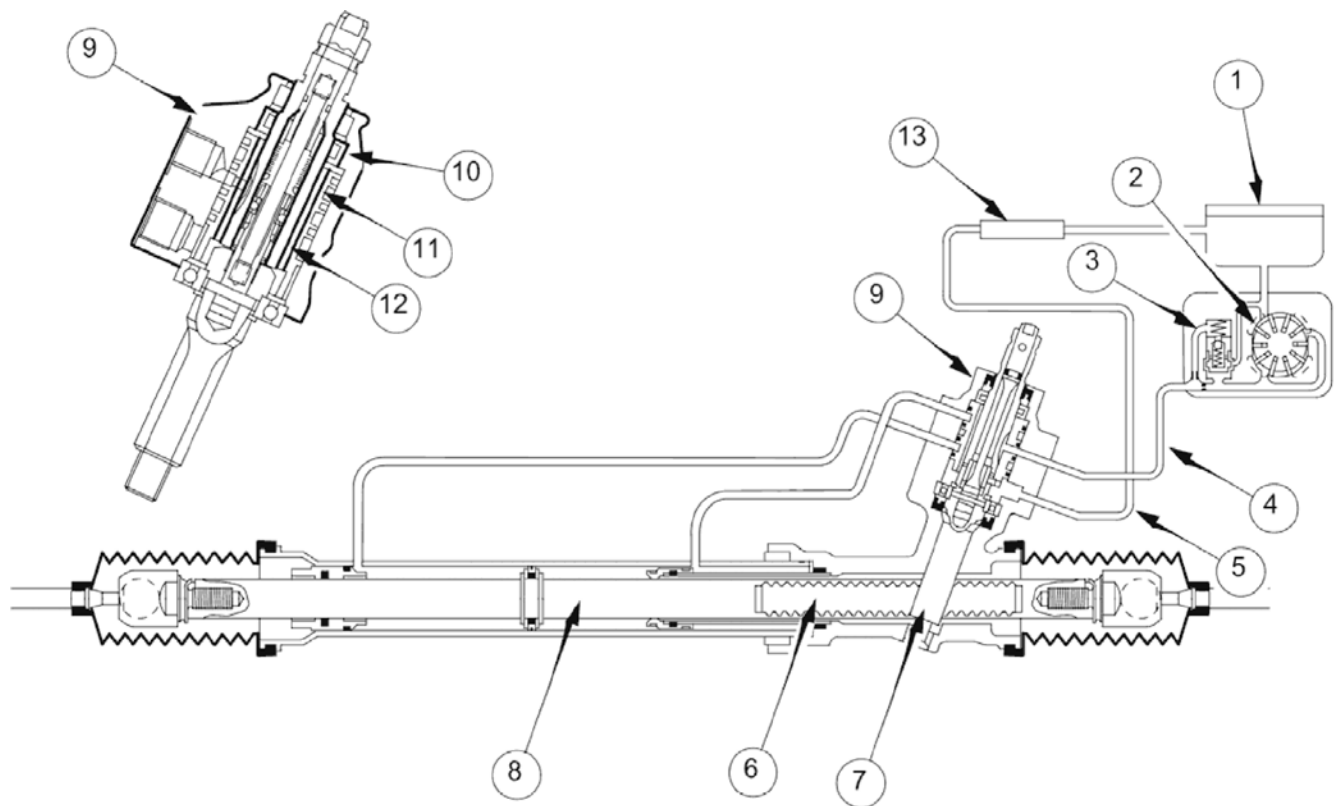

E33874

Parts List

Item	Description
1	Fluid reservoir
2	Pump
3	Pressure and flow limiting valve
4	Supply line
5	Return line
6	Steering rack
7	Pinion
8	Operating cylinder and piston
9	Hydraulic control valve
10	Hydraulic reaction piston
11	Control sleeve
12	Rotary distributor
13	Fluid cooler

Hydraulic System Operating Principle

The rotary motion of the steering wheel is converted, via the steering rack pinion, to the lateral motion of the rack. Steering assistance is provided by pressurized fluid being directed against a piston operating within the rack cylinder. Rack movement is achieved by differential pressures being applied on either side of the rack piston, caused by unequal restrictions within the hydraulic control valve.

The main components of the hydraulic control valve are the rotary distributor, control sleeve and hydraulic reaction piston. The rotary distributor and control sleeve turn relative to each other, forming the unequal restrictions which

1998 XJ RANGE - Power Steering - 211-02

create the differential pressures to operate the rack piston; the displacement of the distributor and sleeve being controlled by the elastic deformation of a torsion bar which is concentric with the pinion and valve. Refer to Positive Center-Feel Torsion Bar in this sub-section.

The hydraulic reaction piston moves axially, relative to the rotary distributor, and is connected to the control sleeve by a three-bearing helical screw. Pressure applied either side of the hydraulic reaction piston is translated into a rotational force which increases steering effort. For details of Servotronic speed-sensitive steering control, refer to Servotronic Control in this sub-section.

When the vehicle is travelling straight ahead, the valve restrictions are balanced, thus providing equal pressures on either side of the rack piston. When load is applied at the steering wheel, the two halves of the control valve (rotary distributor and control sleeve) are displaced making the restrictions unequal. The resulting differential pressures on either side of the rack piston, assist the steering rack to move to left or right. As the turning load is removed, the pressures equalize again and the steering returns to the straight ahead position, aided by suspension geometry.

Servotronic Control

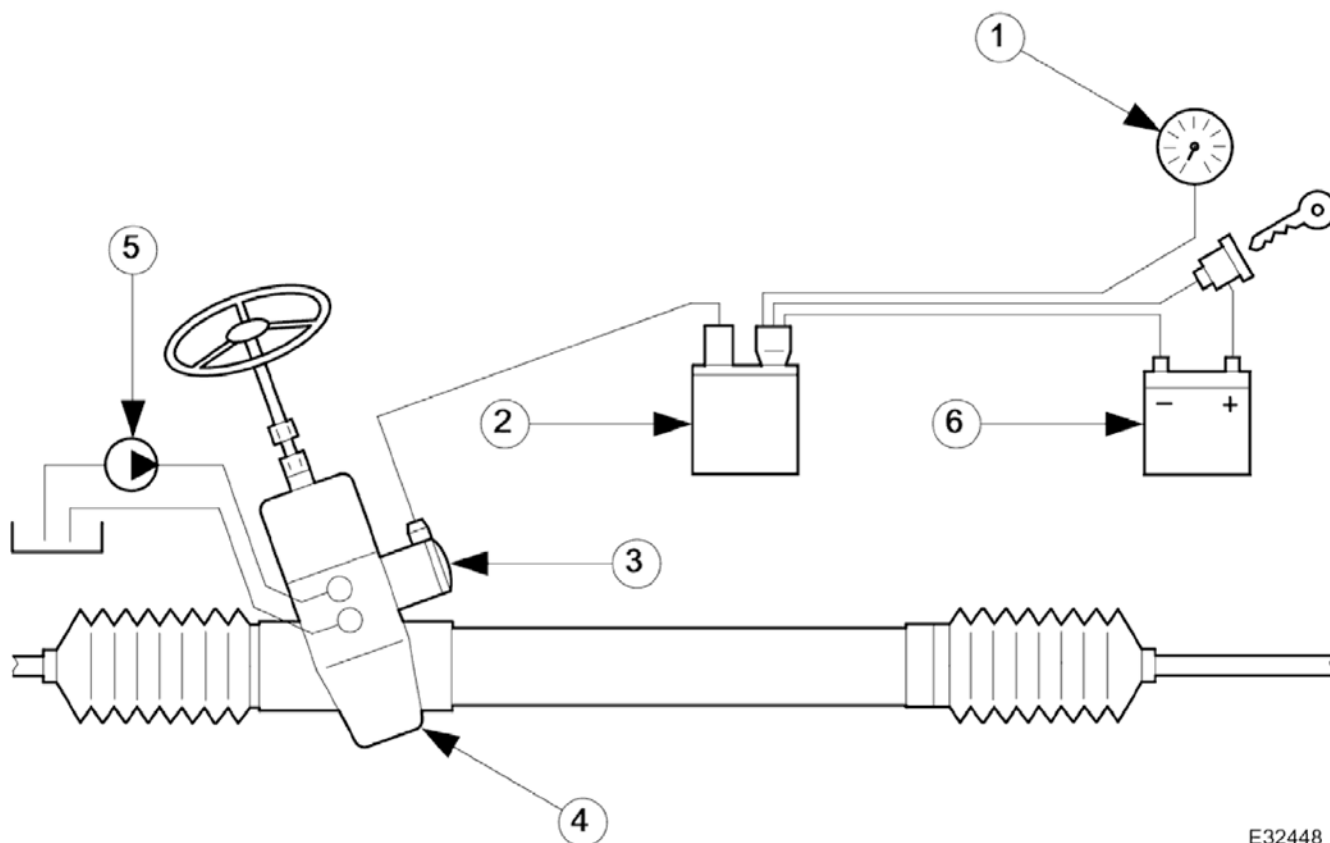

E32448

Parts List

Item	Description
1	Vehicle speed input
2	Steering control module
3	Servotronic valve
4	Hydraulic control valve housing
5	PAS steering pump
6	Battery

1998 XJ RANGE - Power Steering - 211-02

The Servotronic system provides steering assistance which is proportional to vehicle speed. It comprises the steering control module, and Servotronic valve forming part of the hydraulic control valve assembly.

The Servotronic valve is an electro-hydraulic device with a variable orifice, which varies in size according to the position of a needle valve. The needle valve is controlled by a solenoid in response to a variable current input from the steering control module. This regulates the fluid flow through the hydraulic control valve, which determines the amount of steering assistance.

Steering Control Module

The steering control module receives the vehicle speed from the instrument cluster and outputs the corresponding current values to the Servotronic valve. At parking speeds, when maximum assistance is required, the current is at its maximum value of 854 mA and the valve is closed. As the vehicle speed increases, the current progressively decreases to its minimum value of 15 mA and the valve opens in small increments. This results in an increasing amount of hydraulic pressure being applied to the reaction piston, making the steering feel more precise and responsive.

The rate of progression and shape of the characteristic between parking and high speed operation, is determined by the algorithm within the steering control module, and is matched to each suspension variant within the vehicle range.

Control Module Connections

1998 XJ RANGE - Power Steering - 211-02

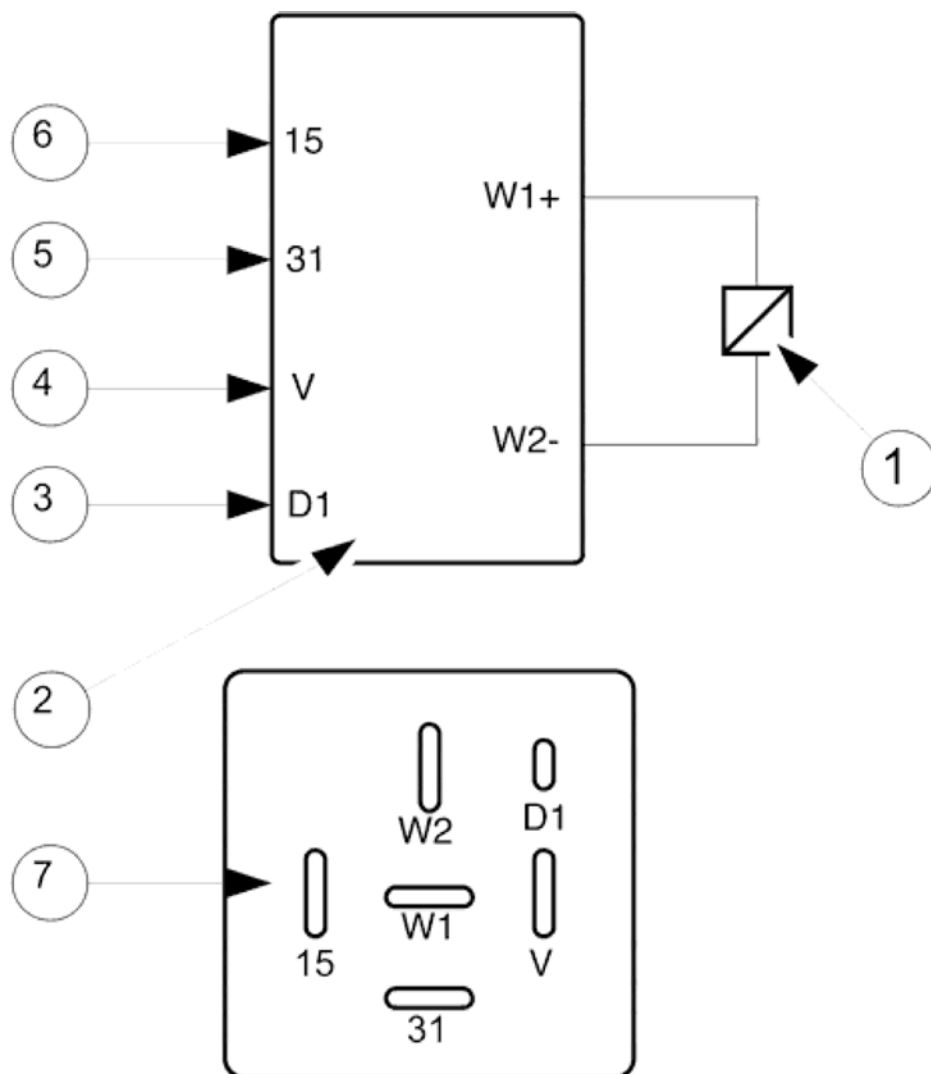

E35275

Item	Description
1	Servotronic valve
2	Steering control module
3	Not used
4	Vehicle speed input
5	Ground
6	Ignition supply +12V
7	Base of steering control module