

1998 XJ RANGE - Engine Cooling - 303-03A

Thermostat Vehicles Without: Supercharger 26.45.07

Removal

1. Open the engine compartment and fit paintwork protection sheets.
2. Drain the radiator. Refer to General Procedures. Retain the coolant drain tray in position to catch any spillage when removing the thermostat cover.
3. Remove the engine cover panels for access.

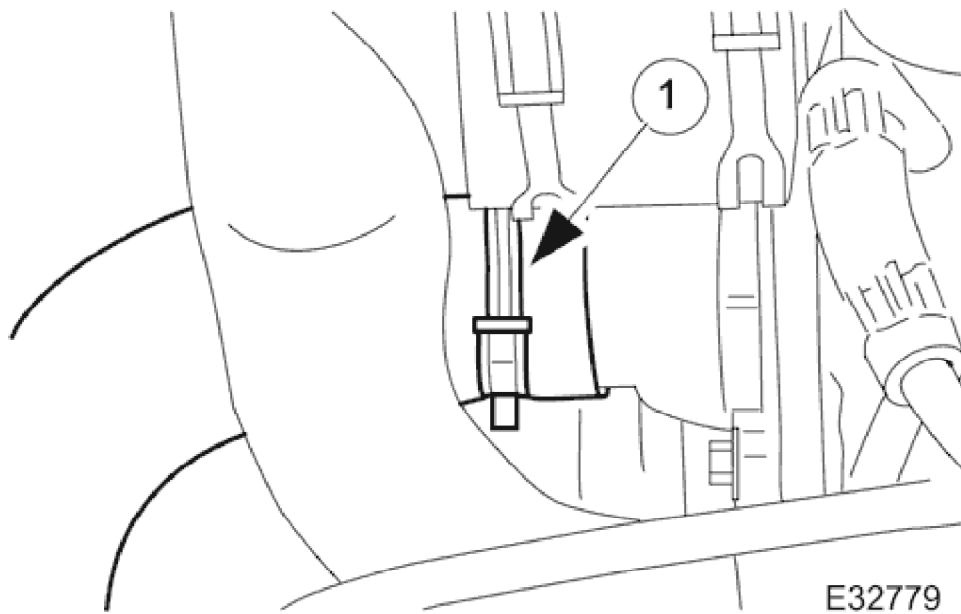

4. Disconnect the radiator bottom hose from the thermostat cover.
 1. Release and reposition the hose clip, and disconnect the bottom hose from the thermostat cover.

1998 XJ RANGE - Engine Cooling - 303-03A

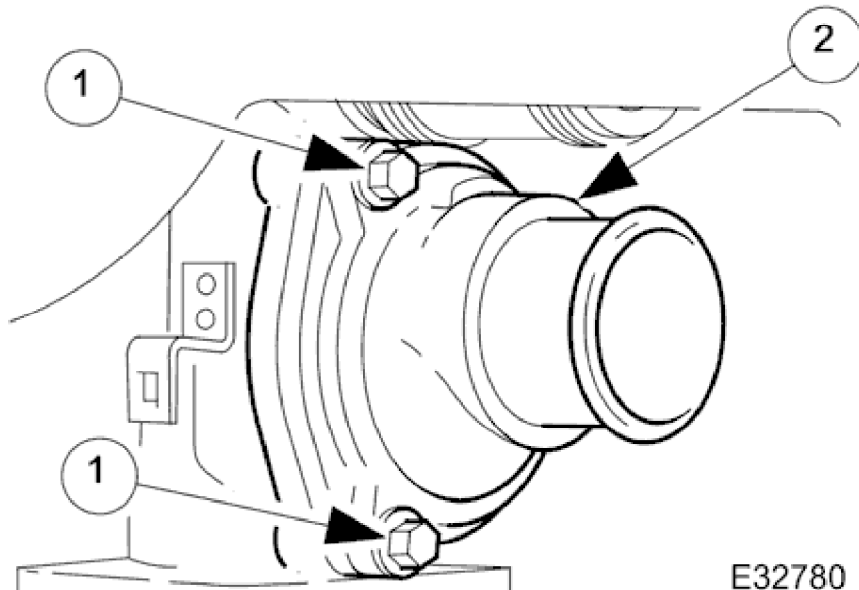

E32780

5. Remove the thermostat cover.
 1. Remove the three bolts which secure the thermostat cover to the housing.
 2. Remove the thermostat cover from the housing.

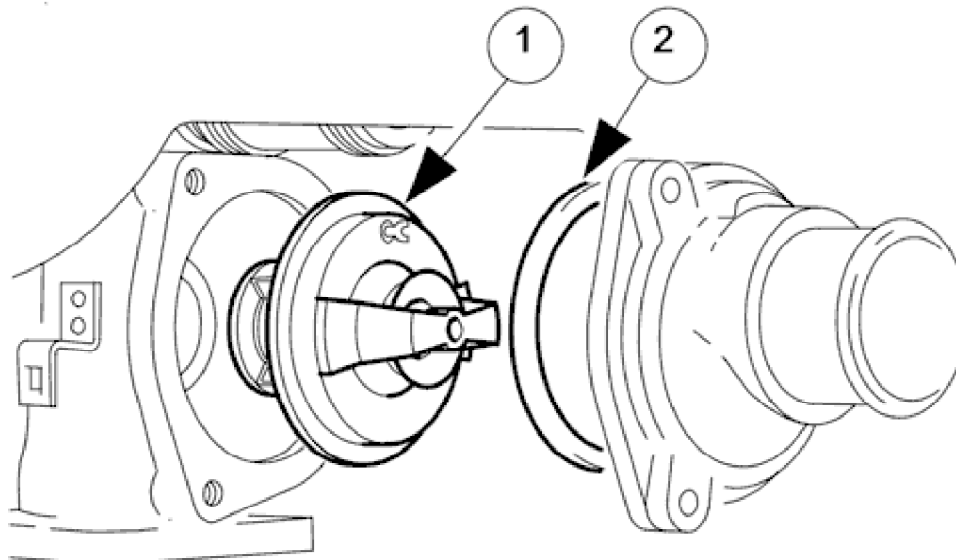

E32535

6. Remove the thermostat from the housing.
 1. Remove the thermostat from the housing.
 2. Remove (and discard) the seal from the thermostat.
 - Fit a new seal to the thermostat. The seal may be fitted either way round.

Installation

1. Installation is the reverse of the removal procedure.

1998 XJ RANGE - Engine Cooling - 303-03A

2. Fit the thermostat so that the vent ball valve locates in the recess in the cover.

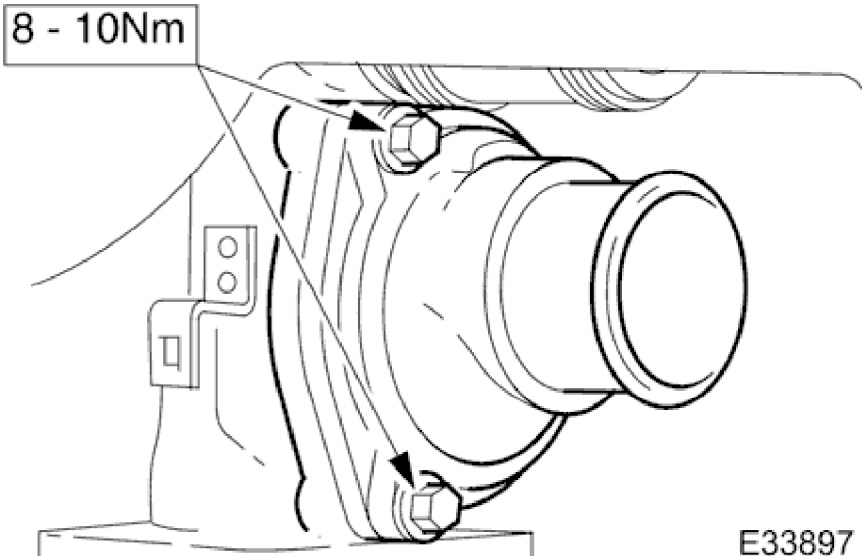

3. Tighten the thermostat cover bolts to 8-10 Nm.

4. Refill the cooling system as described in General Procedures.