

2001 XJ RANGE - Front Suspension - 204-01

Wheel Bearing 60.25.40

Special Service tools

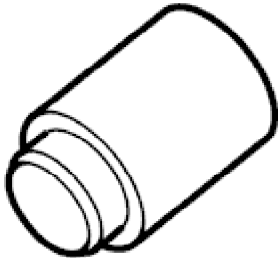

E36390

Hub Remover
204-193 (JD 224)

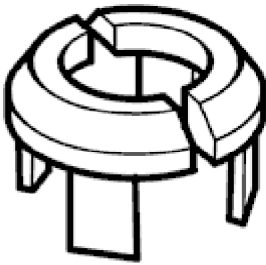

E36391

Hub Removal Collets
204-194 (JD 225)

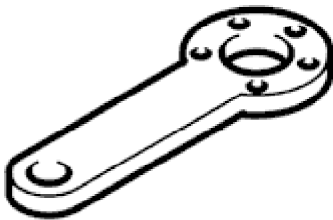

E36410

Hub Holding Tool
204-195 (JD 227)

2001 XJ RANGE - Front Suspension - 204-01

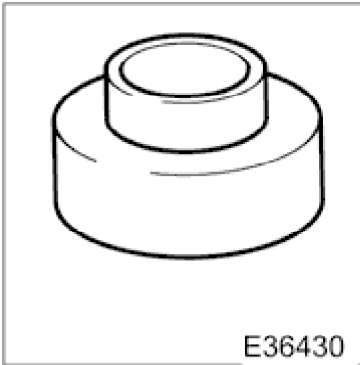

Hub Replacer
204-196 (JD 236)

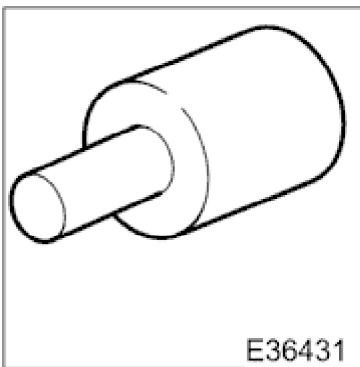

Wheel Bearing Remover
204-197 (JD 237)

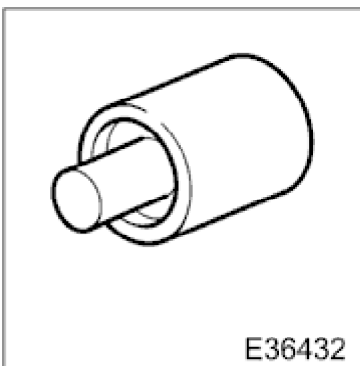

Wheel Bearing Replacer
204-198 (JD 238)

2001 XJ RANGE - Front Suspension - 204-01

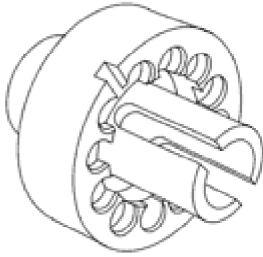

E36443

ABS Rotor Nut Socket
206-066A

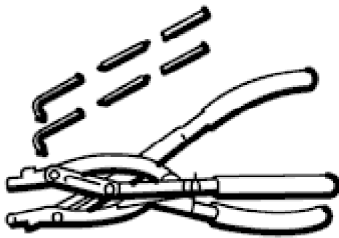

E36412

Circlip Pliers
18G 1004

Removal  **CAUTION:**
Replacement of nuts and bolts: Various thread-locking devices are used on nuts and bolts throughout the vehicle. These devices restrict the number of times a nut or bolt can be used. See section <<100-00>> for information.

1. Remove vertical link and hub assembly. Refer to <<60.25.38.90>>.

2001 XJ RANGE - Front Suspension - 204-01

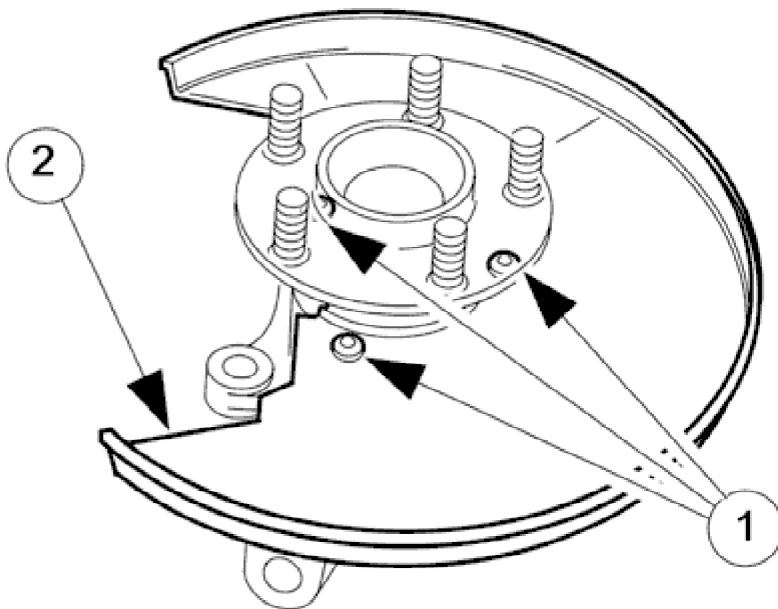

E32292

2. Remove brake disc shield from vertical link.
 1. Remove screws.
 2. Remove disc shield.

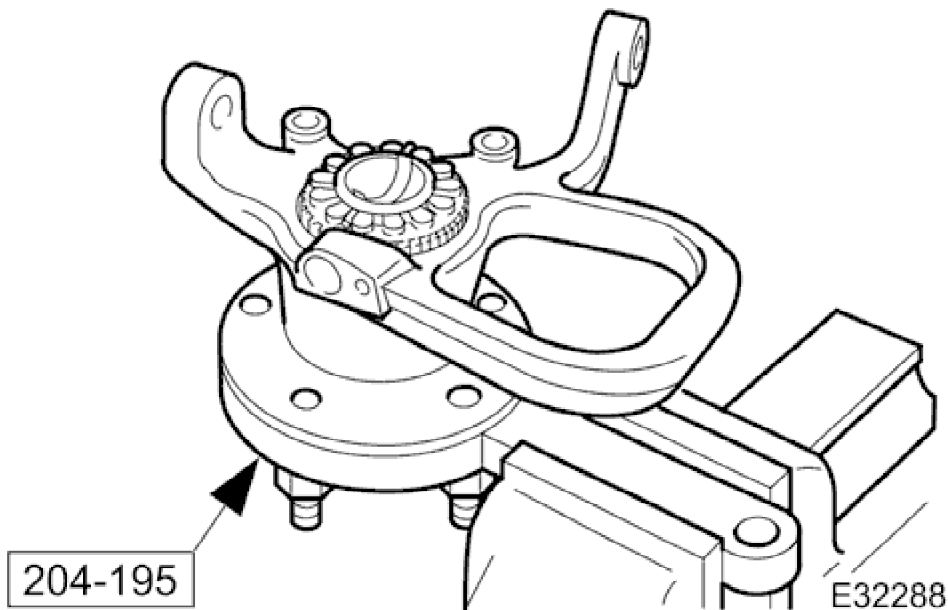

3. Using special tool, secure vertical link and hub assembly in a vise.
 - Secure special tool in a vise.
 - Position hub in tool.
 - Install wheel nuts.

2001 XJ RANGE - Front Suspension - 204-01

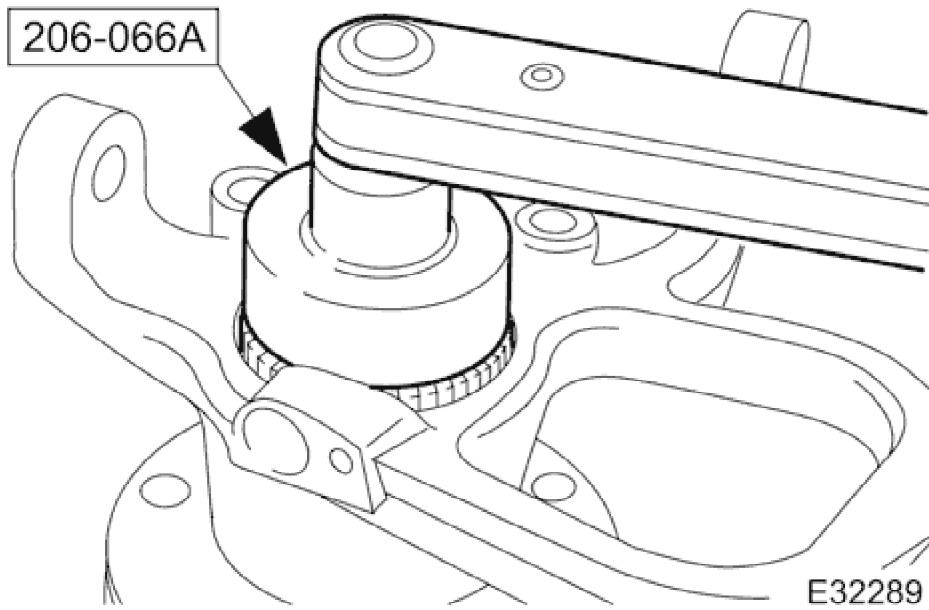
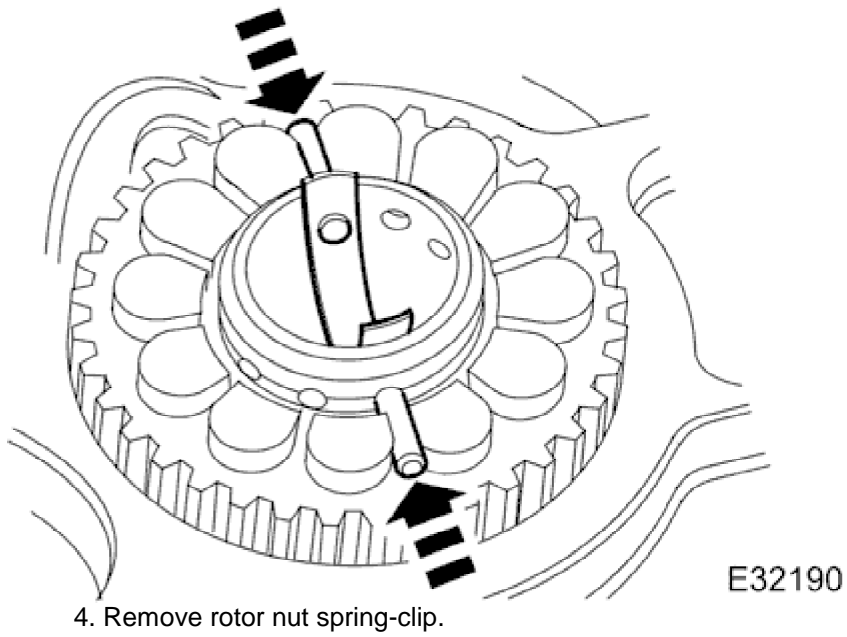

2001 XJ RANGE - Front Suspension - 204-01

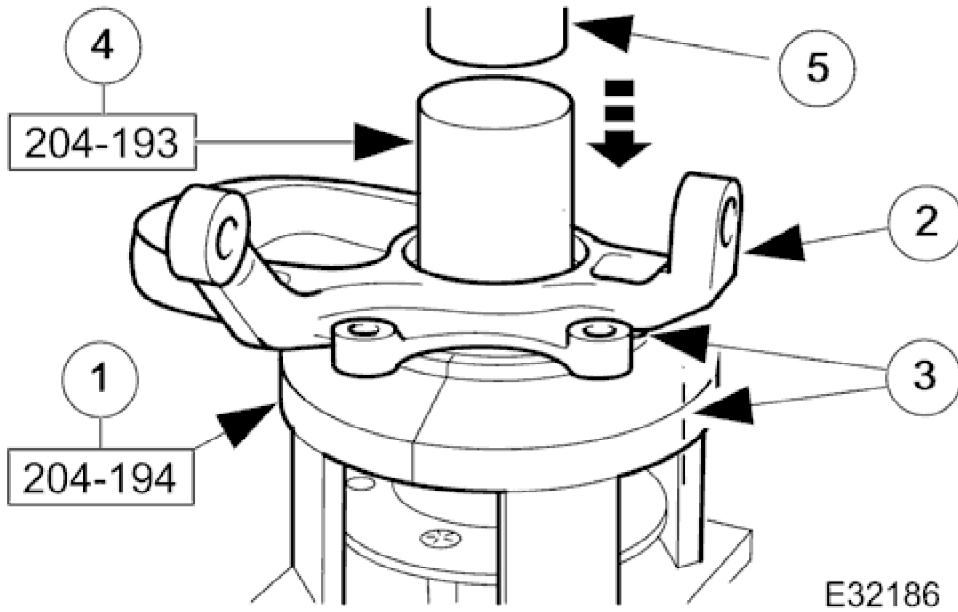

7. Using a hydraulic press, remove hub from vertical link.
1. Place special tool 204-194 on press bed.
 2. Position vertical link and hub assembly into tool collets.
 3. Ensure one of the disc shield screw-bosses is in the center of one of the tool collets.
 4. Position special tool 204-193 on top of hub.
 5. Operate press to remove hub from vertical link.

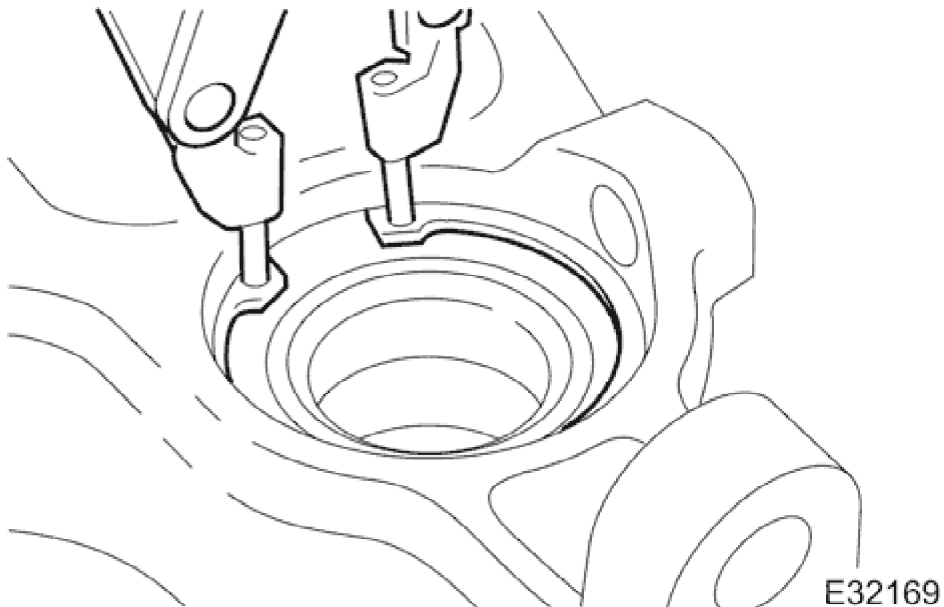

8. Using special pliers, remove and discard inboard circlip from the vertical link.

2001 XJ RANGE - Front Suspension - 204-01

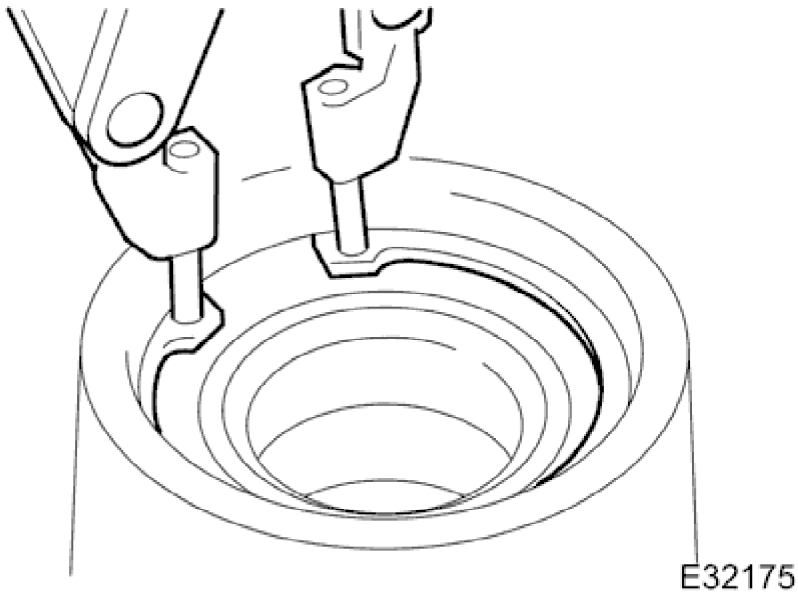

9. Using special pliers, remove and discard outboard circlip from the vertical link.

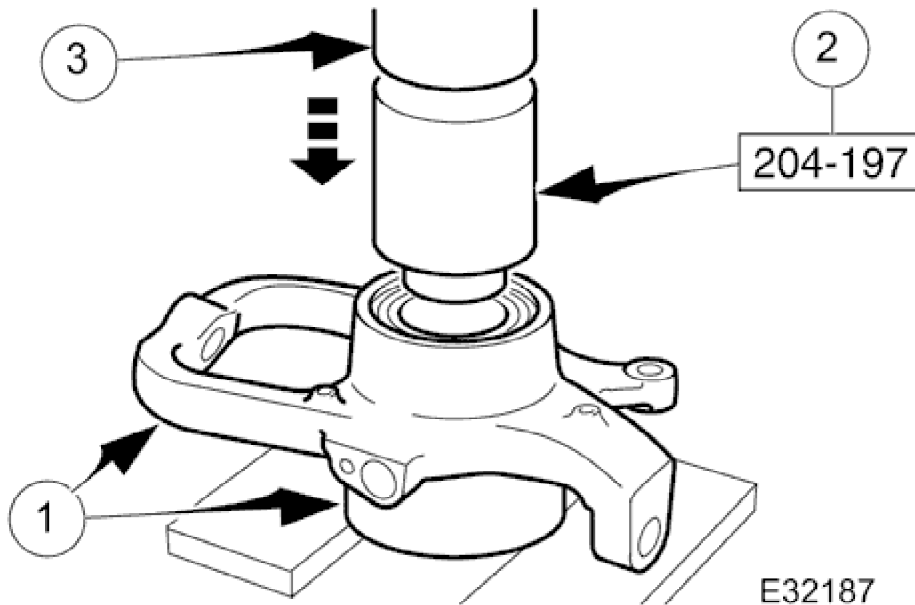

10. NOTE:

Ensure the vertical link is level, and the supports are situated as near to the bearing bore as possible.

Using a hydraulic press, remove wheel bearing from vertical link.

1. Position the vertical link so that inboard side of the bearing bore is resting on suitable supports on the press-bed.
2. Position special tool 204-197 on top of bearing.
3. Operate press to remove bearing from vertical link, discard bearing.

2001 XJ RANGE - Front Suspension - 204-01

11. Clean relevant parts.

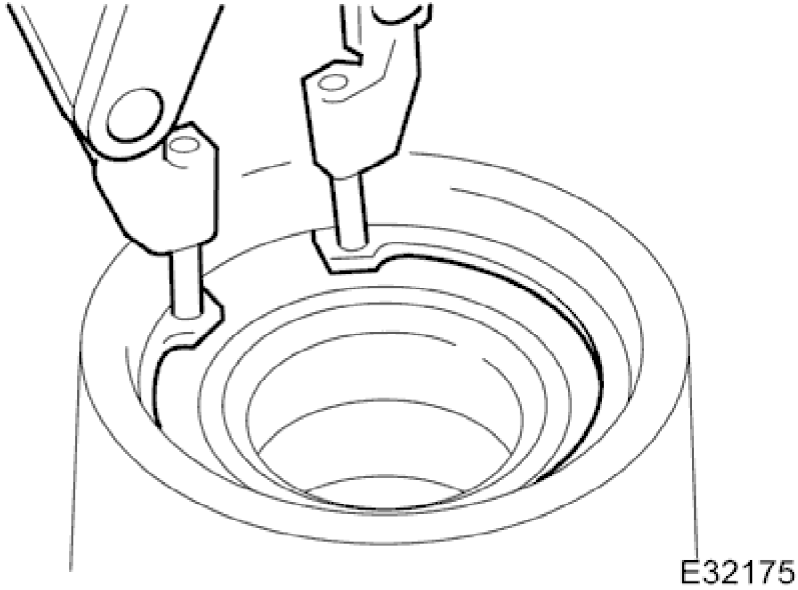

1. NOTE:

The gap between the ears of the circlip must be positioned so that it is in the lowest position of the bore when the vertical link is installed on the vehicle. Refer to General Procedures for further information.

Install outboard circlip in vertical link.

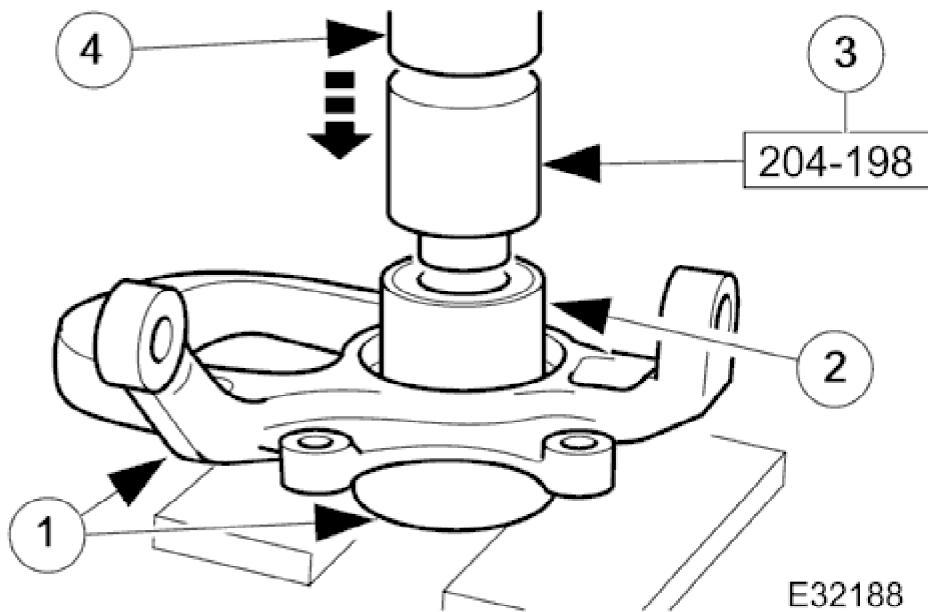

2. Using a hydraulic press, install bearing in the vertical link.

2001 XJ RANGE - Front Suspension - 204-01

1. Position vertical link on the press bed with outboard side of the vertical link face down.
2. Position bearing on vertical link.
3. Position special tool on top of wheel bearing.
4. Operate press to install bearing, applying a three-ton load to ensure that the bearing is fully seated.

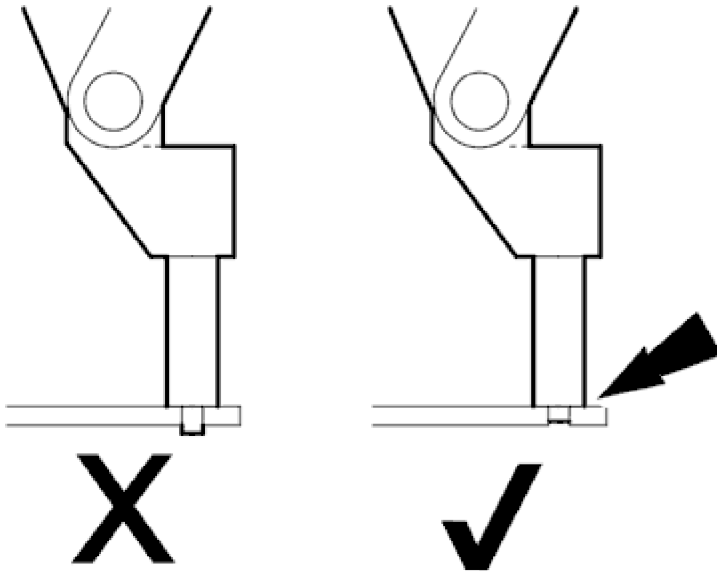

E32170

3.  **CAUTION:**
To prevent damage to the integral wheel-bearing seal, select circlip plier ends that do not protrude through the circlip ears.

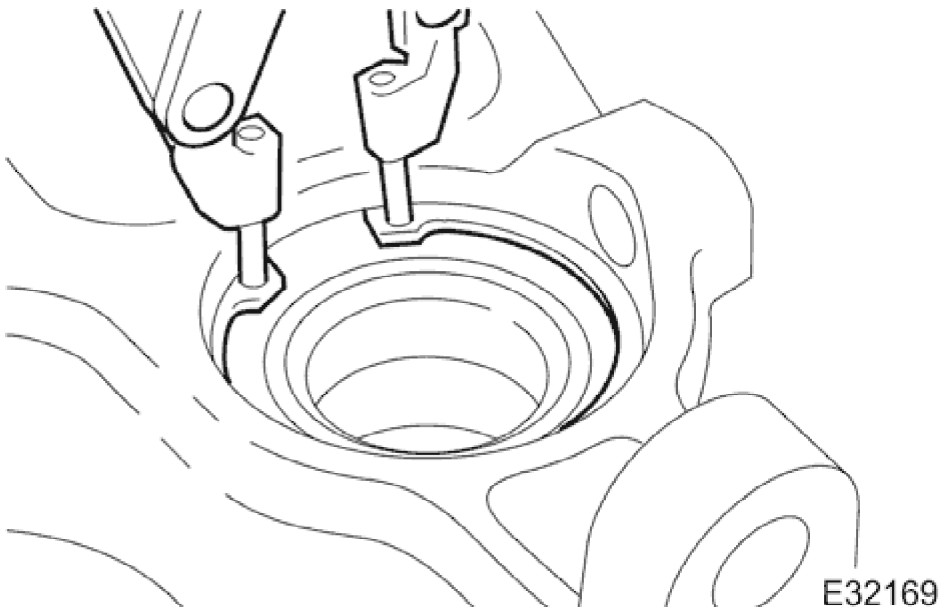

E32169

2001 XJ RANGE - Front Suspension - 204-01

4. NOTE:

The gap between the ears of the circlip must be positioned so that it is in the lowest position of the bore, when the vertical link is installed on the vehicle. Refer to General Procedures for further information.

Install inboard circlip in vertical link.

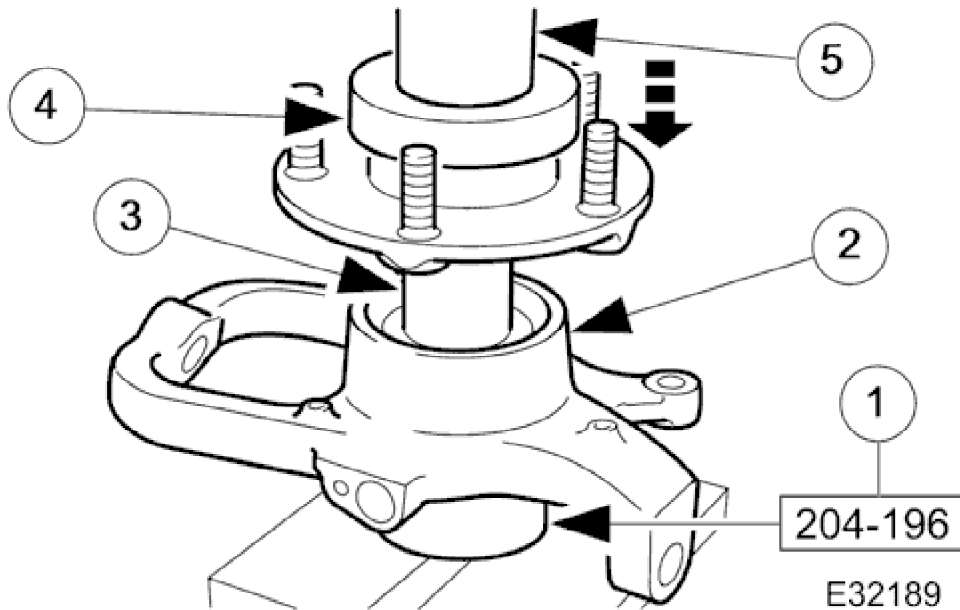

5. Using a hydraulic press, install hub in vertical link.

1. Position special tool on press bed.
2. Position the vertical link on the tool, with the inboard-side face down.
3. Position hub on bearing.
4. Position a flat steel plate across the face of the hub, DO NOT place plate across wheel studs.
5. Operate press to install the hub, applying a three-ton load to ensure hub is fully seated in bearing.

2001 XJ RANGE - Front Suspension - 204-01

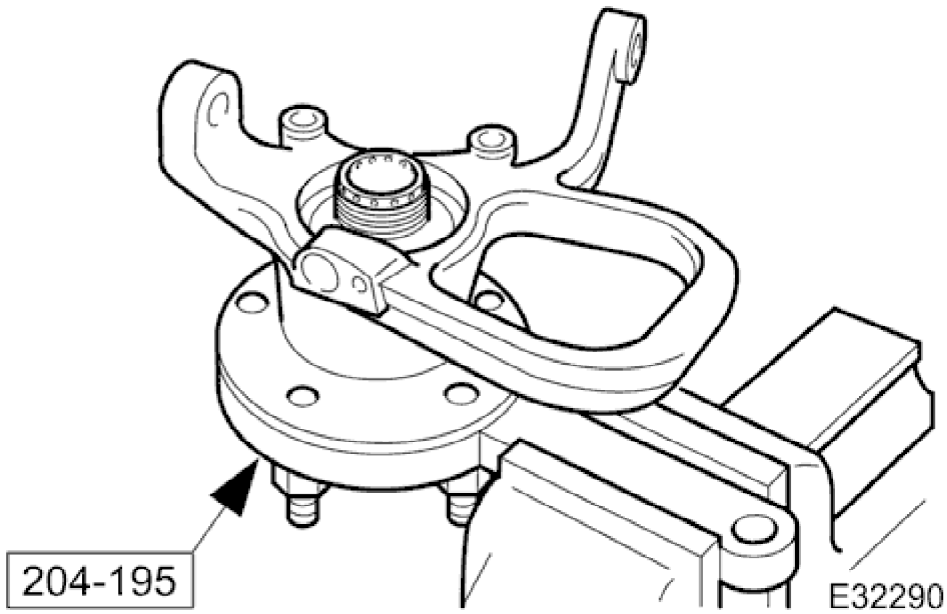

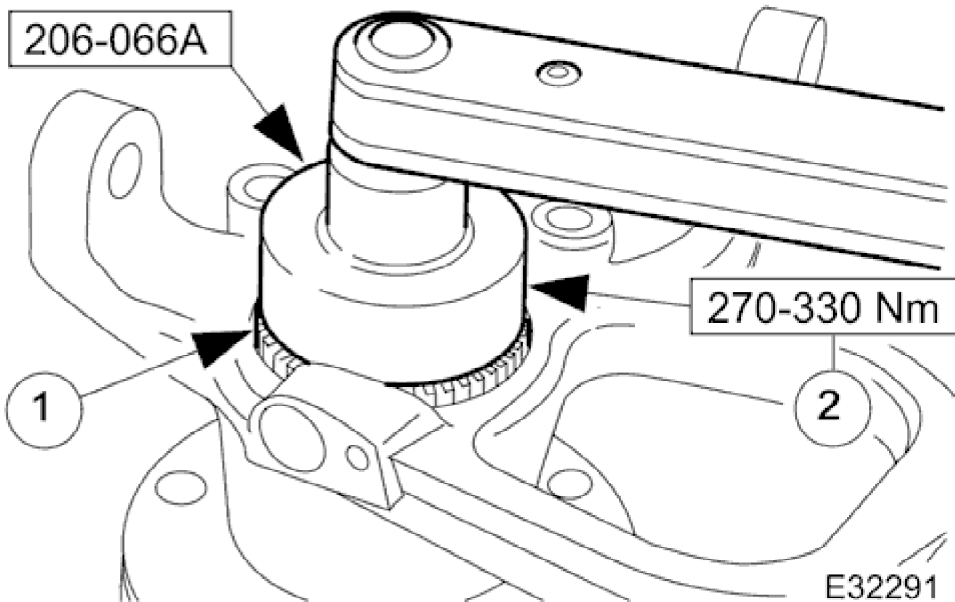

6. Using special tool, secure vertical link and hub assembly in a vise.
- Secure special tool in a vise.
 - Position hub in tool.
 - Install wheel nuts.

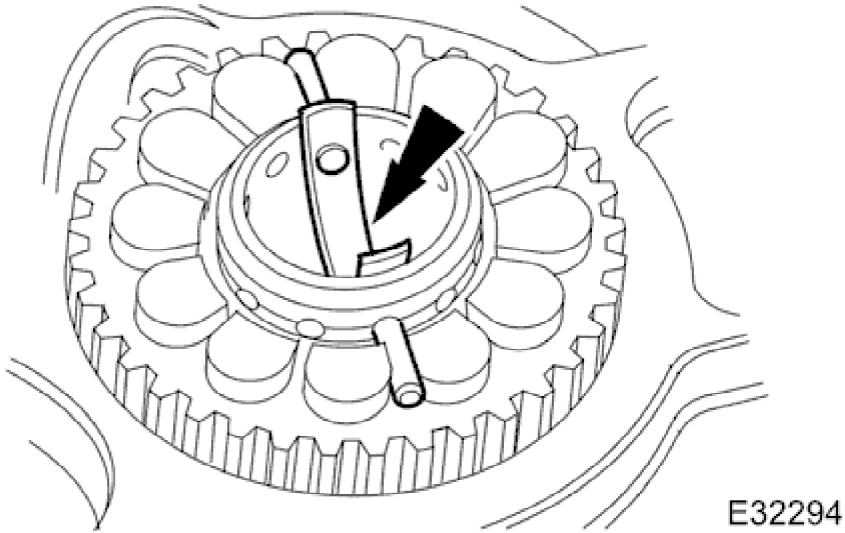

7. Install rotor nut .
1. Install rotor nut on hub.
 2. Using special tool tighten rotor nut.

2001 XJ RANGE - Front Suspension - 204-01



8.  **CAUTION:**
Do not slacken the rotor nut to engage the spring clip.

NOTE:

If the castellated slots of the rotor nut are not aligned, tighten the rotor nut further until the spring clip engages the slots.

Install rotor nut spring-clip.

- Install spring clip in hub retaining holes and castellated slots of the rotor nut.

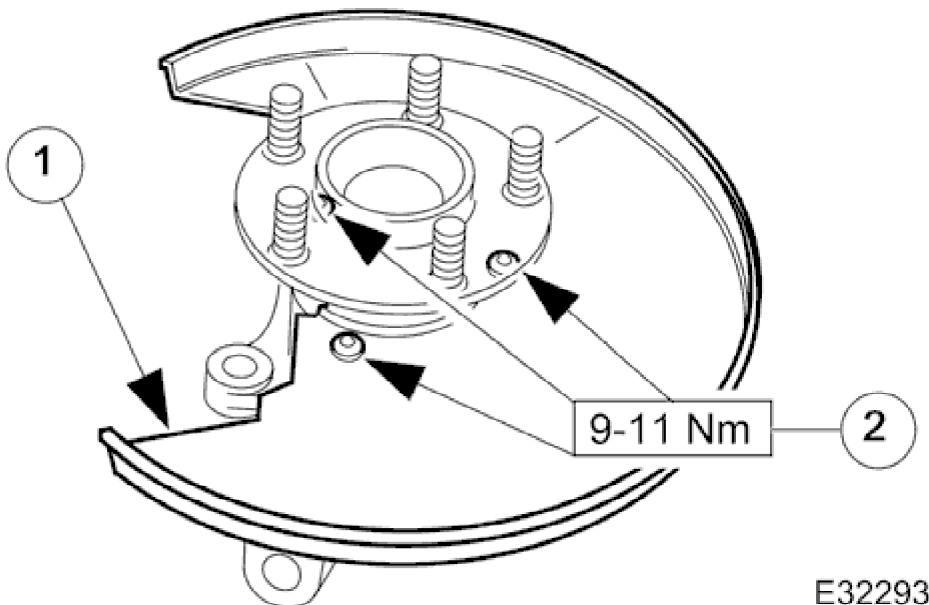

9. Install disc shield.
1. Position disc shield on vertical link.
 2. Install bolts.

2001 XJ RANGE - Front Suspension - 204-01

10. Install vertical link and hub assembly on vehicle. Refer to <<60.25.38.90>>.

Carry out steering geometry and wheel alignment checks and if necessary adjust. Refer to <<57.65.01>>.