

Replacing the Auxiliary Air Valve (AAV)

Introduction

The AAV is a device to aid the cold start of the Jaguar V12 engine, and was fitted to all models of the V12 that were installed in the XJS throughout its 21 year production run. This type of device, originally a Bosch design, was fitted to many different cars made in Europe during the same production era. It works by having an extra airway into the inlet manifold that opens when the coolant is cold to increase engine RPM, which progressively closes as the engine warms up. The actuating device is a thermostatic bulb, quite similar to that used in a car radiator thermostat. This pushes a steel piston up into a cast aluminium cylinder, and the piston thus progressively closes off an air passage as it rises. Below is a photo of the AAV on the engine (induction manifolds removed in the photo).

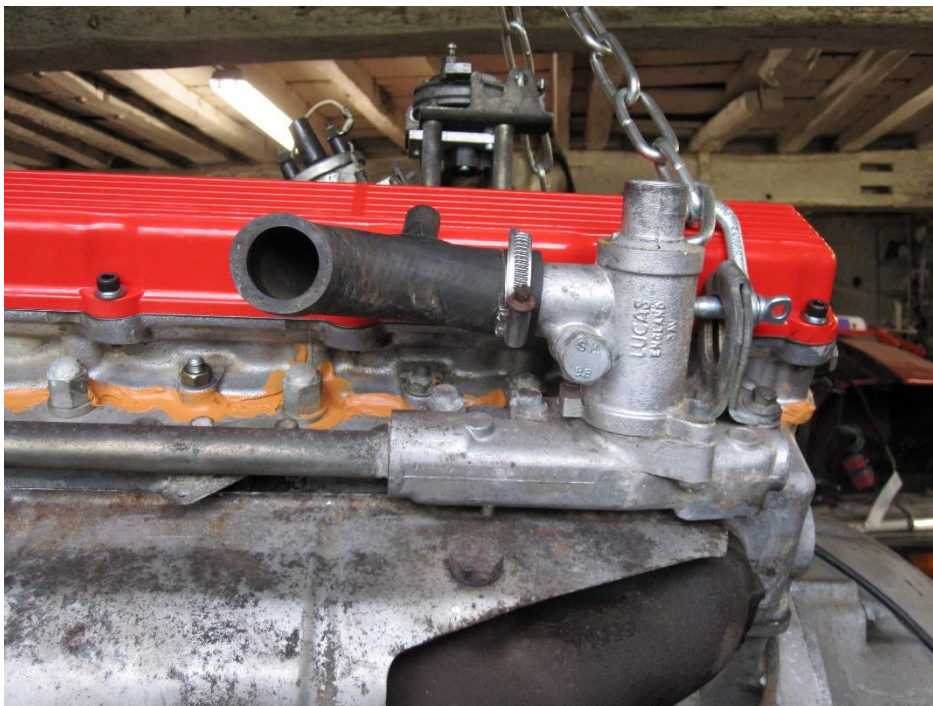

The AAV works very reliably in my experience, **unless** the car is not used very frequently. When I used my car daily, it never gave any trouble, but now that I use the car only once or twice a week, and far less in winter, the AAV works far less reliably. The reason is that the cast aluminium cylinder corrodes if not used frequently. This causes the piston to jam, in turn this means the air passage remains open or partially so when the engine is warm, and this causes engine revolutions to exceed 1400 RPM on tickover. The engine's ECU thinks with revs over 1400 and a closed throttle, that the car is coasting on a trailing throttle and therefore stops the fuel injectors operating in order to save fuel. This, in turn, starts a "hunting" sequence whereby the engine races above 1400 rpm, the fuel gets cut so the revs drop, then the ECU starts the fuelling again and so on, giving a high rev/low rev/high rev/low rev cycling about once every 3 or 4 seconds. It is this disconcerting cycling that is the symptom of a failing AAV.

A second important function of the AAV is to provide a slow-running (tickover) adjustment for the engine, and this is operated by a large bolt that screws in or out, and thus closes or opens an air bypass passage incorporated into the AAV casting. This adjusting bolt is obvious in the photo above.

Fixes for a failed AAV

A new AAV is still available and costs over 250 UKP (over 370 USD). The AAV can be taken to pieces quite easily and the piston and aluminium cylinder cleaned up. This procedure is very well explained by Grant Francis and is attached to post no. 9 of this thread:

<http://www.jaguarforums.com/forum/xjs-x27-32/auxiliary-air-valve-rebuild-119510/>

This fix is essentially costless and works very well, but on a less frequently used car the AAV will fail again, sooner or later. Therefore I tried to find a different solution to aid cold starting.

An electrically operated cold start device for the Jaguar V12

A: Modify AAV casting to leave only its tickover adjustment function

I wanted to have an electrically activated driver-controlled cold start device that could be switched on or off from the cabin, while retaining the slow running adjustment function of the AAV. As I had a non-functioning spare AAV, I followed Grant Francis' procedure (see link above) in order to dismantle it. Having taken it apart I removed the cylinder, piston and its return spring from the casting, then rotated the cylinder through 180 degrees to close off the airway, and used epoxy hard-setting putty to completely seal it. In the photo below, the large **blue arrow** indicates the

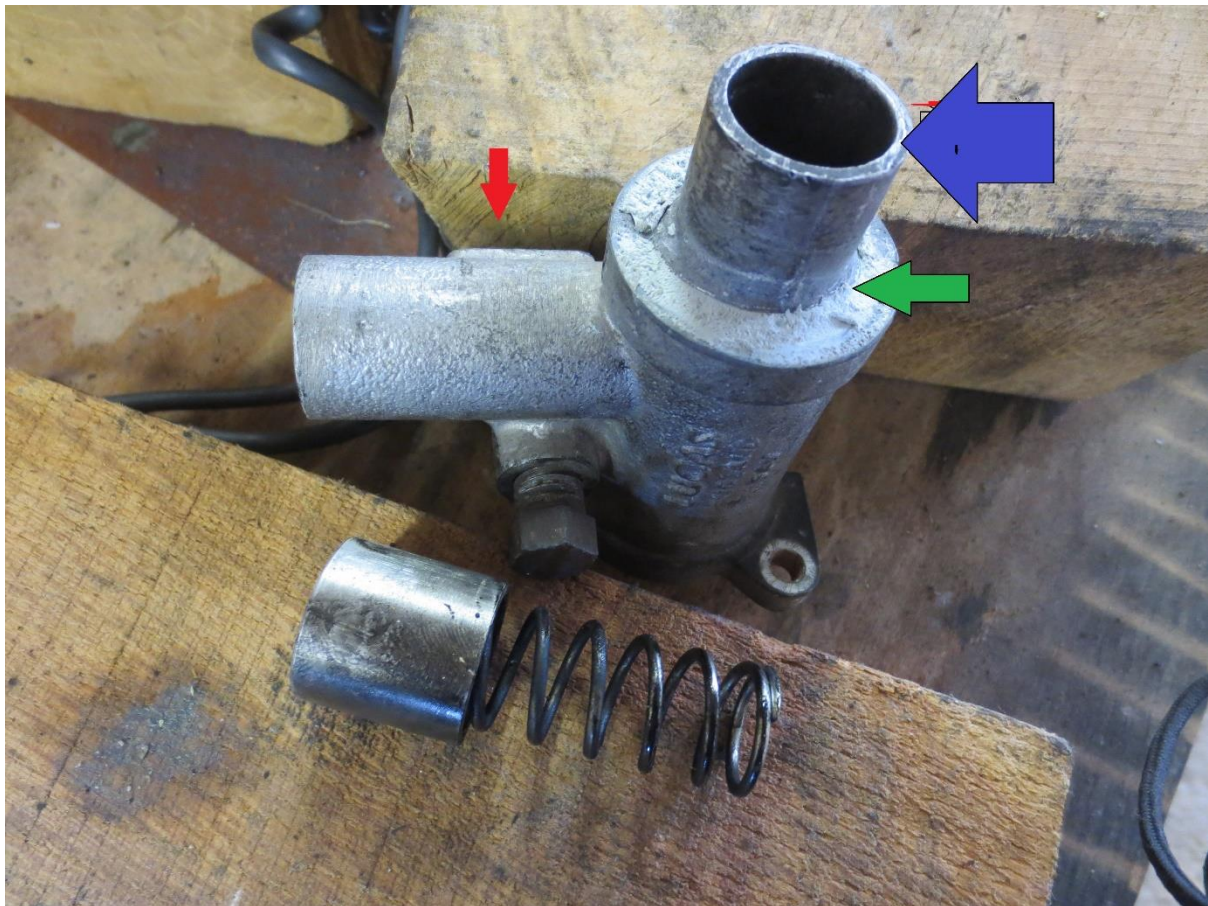

cylinder, the **green arrow** indicates where the cylinder has been released from the outer casing and turned 180 degrees to close the air passage and then resealed; the **red arrow** indicates the air entry tube from the air filter box. The original air passage opening is at the cylinder end of this air passage. The piston has been removed from the unit as is obvious. The following photo shows the air passage at the cylinder end completely sealed with epoxy putty.



An important point to understand is that blocking this air passage does NOT block the function of the slow running adjustment screw. The air passage for the tickover adjustment has a separate route through the casting. In diagrammatic form, this is what has been done:

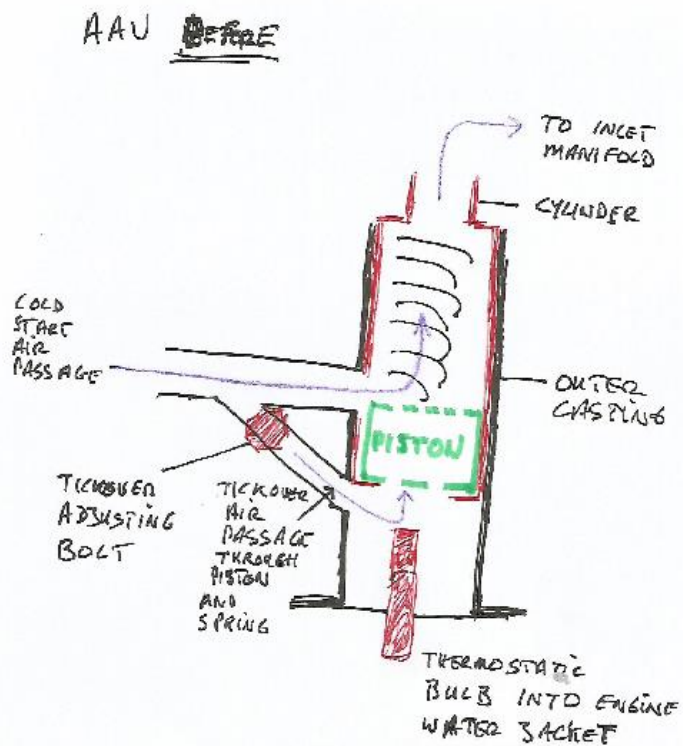

AAV AFTER

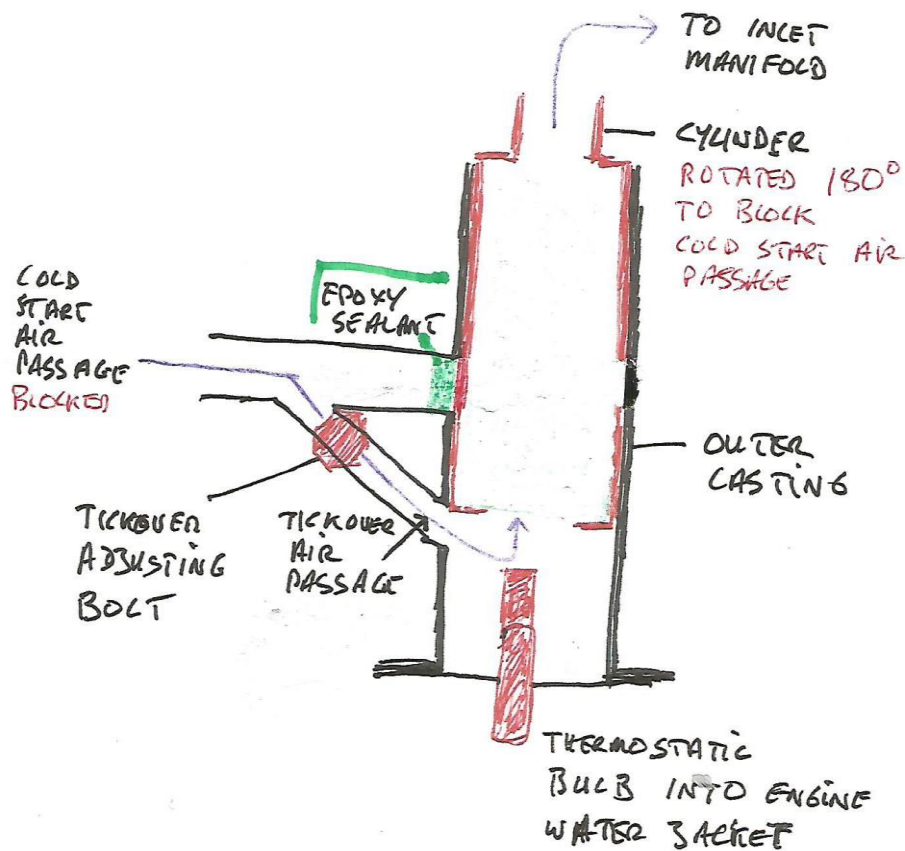

As the diagram shows, the AAV casing has been emptied of its moving parts except for the slow running (tickover) adjustment function. The AAV was then reinstalled on the engine just as before. There is no need to touch the thermostatic bulb.

B: Find an electronic method of providing cold start air flow

The ideal mechanism for this function is an electrically operated solenoid that can be switched on and off from the cabin. The problem was finding a suitable one that gave enough airflow. As standard, many V12 XJSs are fitted with a solenoid that is automatically activated when the air conditioning compressor runs. This is an extra air device to ensure that in traffic, or at a standstill for some other reason, the load produced by the compressor running does not stall the engine if it is ticking over. The OEM solenoid works well for this anti-stall function, but my experiments showed that it does not flow enough air to reliably run a stone cold engine from startup. The bore of the solenoid's air pipe is just too narrow. A photo of this item is shown below:



Various searches produced all sorts of possibilities; but in the end it was an OEM Jaguar item that was the best answer. On the 3.6 litre straight 6 engine, for certain markets only, a dedicated extra air solenoid for cold starting purposes was fitted to the XJS and other Jaguar models in the 1980s. This item was fitted to these engines to do exactly what the AAV does on the V12. The Jaguar Classic parts link is here: <http://www.jaguarclassicparts.com/uk/jaguar-xj6-parts/engine-management-emission-systems/idle-speed-components/idle-air-valve-3-6-litre>

In the diagram below the part concerned is No. 8:

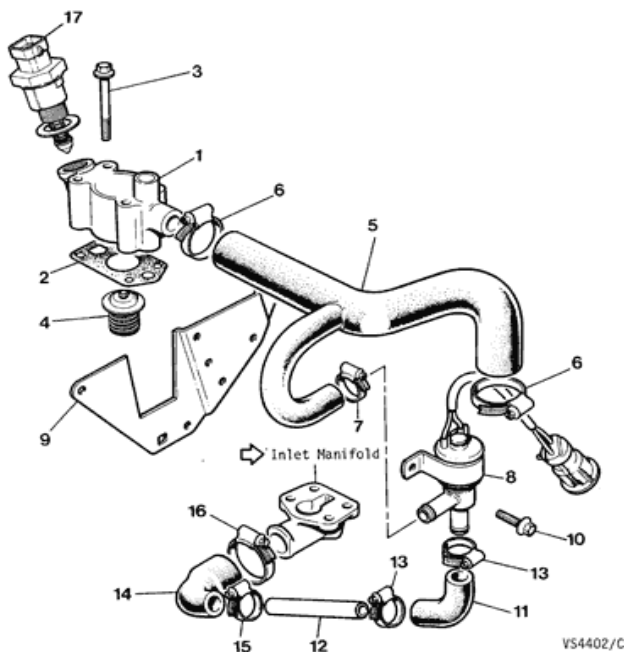

In the diagram, the air inlet is at the side of the solenoid and the outlet to the manifold is at the bottom of the unit. This solenoid flows enough air to enable the V12 to tickover at about 800 RPM when stone cold at an ambient temperature of 0 degrees C (32 F). The photo below shows the unit:



C: Installing the cold start solenoid

The next problem to solve was where to install the solenoid and how to link it into the inlet manifolds. There were three possibilities, it seemed to me. The first was to connect it somehow to the gutted AAV casting. This would probably involve drilling a hole into the side of the casing and mounting the solenoid directly to it, then rigging up a filtered air supply to the solenoid. In fact, I believe that that for many owners, this would be a viable solution. However, there are considerable space difficulties to overcome, depending upon the exact model and whether LHD or RHD. The second possibility would be to connect the solenoid to the large balance pipe that runs across the rear of the engine to balance the manifold pressures. This would also be a viable option, and providing the cross pipe was demounted so a suitable sized spigot could be welded into it, would be a good solution.

The third option, which I decided upon was made easier in my particular case because (a) I have removed the PCV system and am running the crankcase ventilation to atmosphere via a catch tank. Therefore a filtered air supply was available from the hole in the B bank airbox that used to be the outlet of the PCV system into the manifolds; and (b) I have removed the cruise control hardware from the V. Therefore I decided to utilise the (now redundant) entry point into each manifold throttle body that used to be the PCV system manifold inlets. I have Grant Francis to thank for this idea and for the PCV removal idea too.

The photo below shows the PCV airbox to manifold pipe (basically a T shaped affair) before removal. In early experiments I used this pipe as the cold start air feed from the solenoid, while it worked, it was too small a bore to flow sufficient air immediately after a cold start on a really cold day, so the engine did not run evenly for the first minute or so. Using a 13mm ID pipe cured this problem.

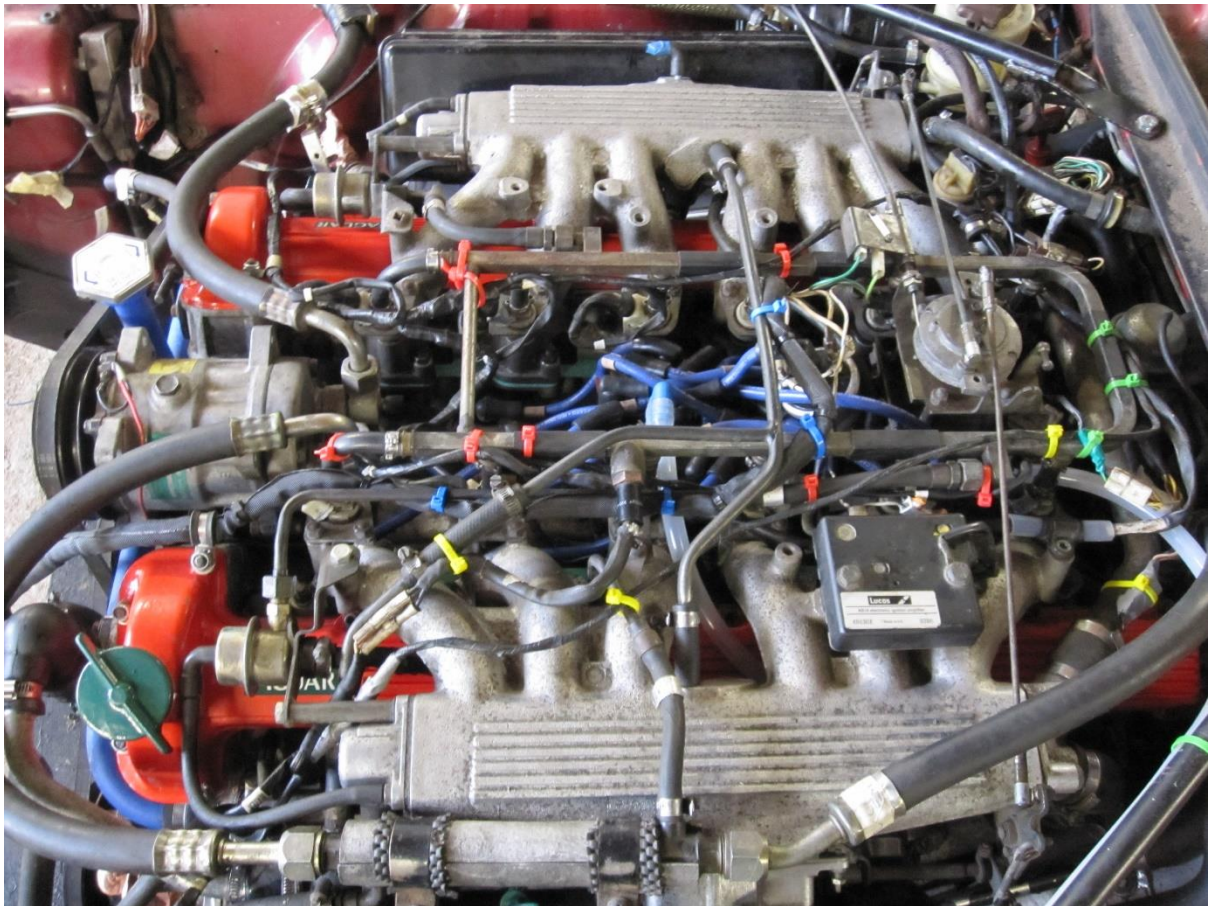

The pipe concerned is the grey steel one that runs across the middle of the engine from the top centre of each manifold, and then the leg of the T shape runs forwards (leftwards in the photo) and downwards behind the manifold at the bottom of the photo. It has a yellow cable tie on it (the leftmost yellow tie in the photo) and a blue cable tie on it in its centre between the manifolds.

Although invisible in the photo, this pipe actually runs to the inside face of the B bank airbox. At the front end of the airbox there is an inlet from the crankcase breather. This breather inlet was blocked off as the crank breather on my car goes to a catch tank. The solenoid was installed on the rear of the B bank airbox, utilising the hole to which the removed manifold pipes and PCV sprung valve were connected before removal. The photo below shows the solenoid installation on the airbox:

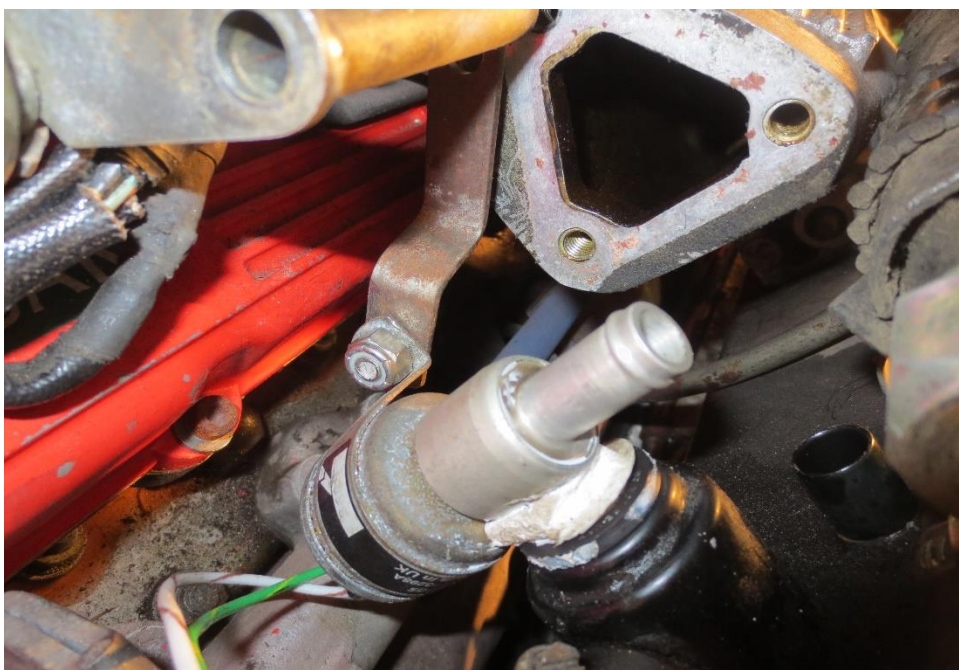

Various pieces of the manifold assembly had to be removed get access to fit the solenoid, but it is quite obvious what to do when you are looking at an actual engine. The following photo shows it all installed and the various bits that had to be removed for access purposes reattached to the B bank manifold. The flexible exit pipe from the solenoid can be seen clearly, linking to the gold steel pipe with a sprung clamp.



The following two photos show how the solenoid is connected to the inlet manifolds. In the first photo, the gold steel pipe with the spring clamps (shown in close-up above) is running under the fuel pressure regulator and is connecting to the main silicone tubing. This tubing is thick walled 13mm ID fibre-reinforced silicone tubing with a Y fitting to split the feed, as shown in the second photo below. Thick walled tubing is needed to prevent it collapsing under manifold vacuum when the system is switched off. In the second photo the silicone tubing, Y connector and tubing to the manifold throttle body inlet spigots is clearly visible; as is the wrapped loom to the system and the fused feed from the coil.

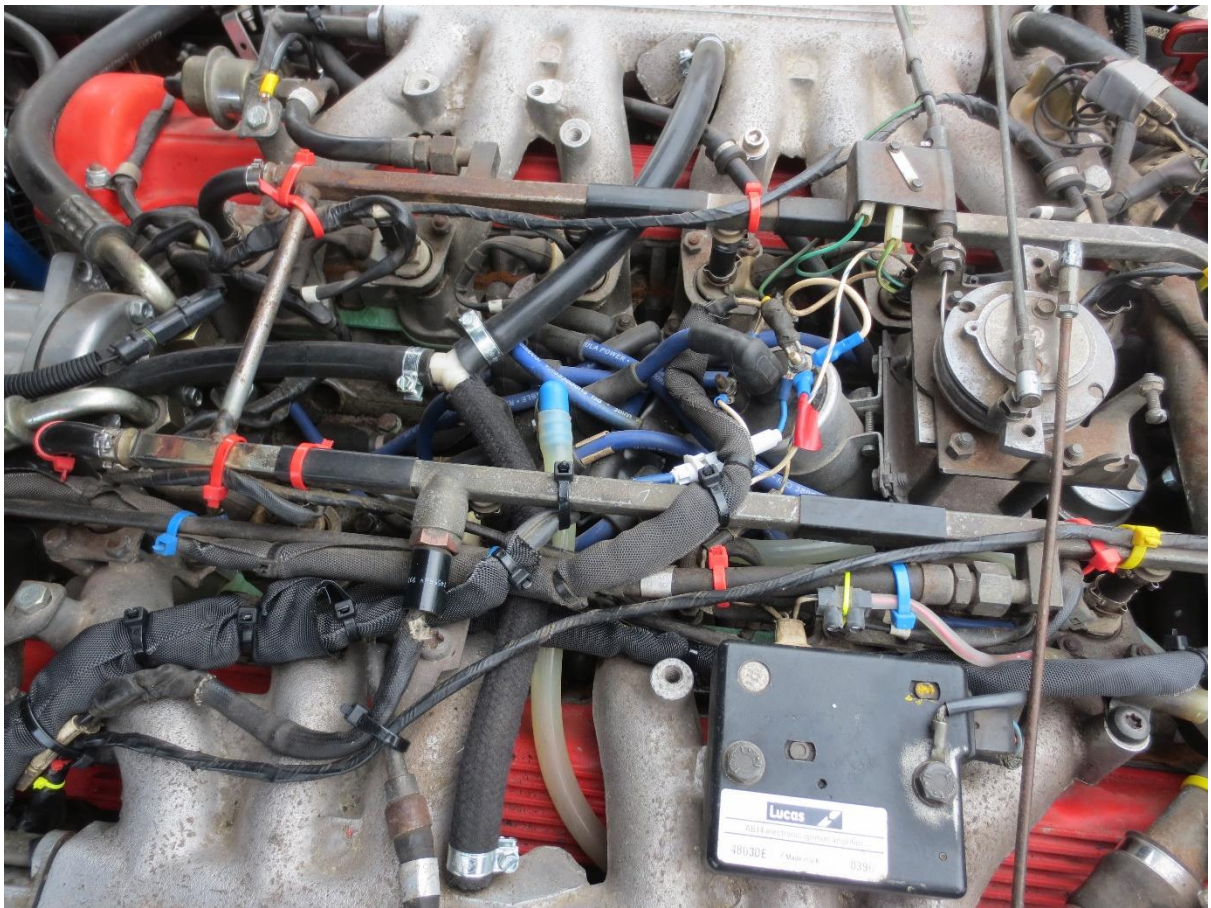
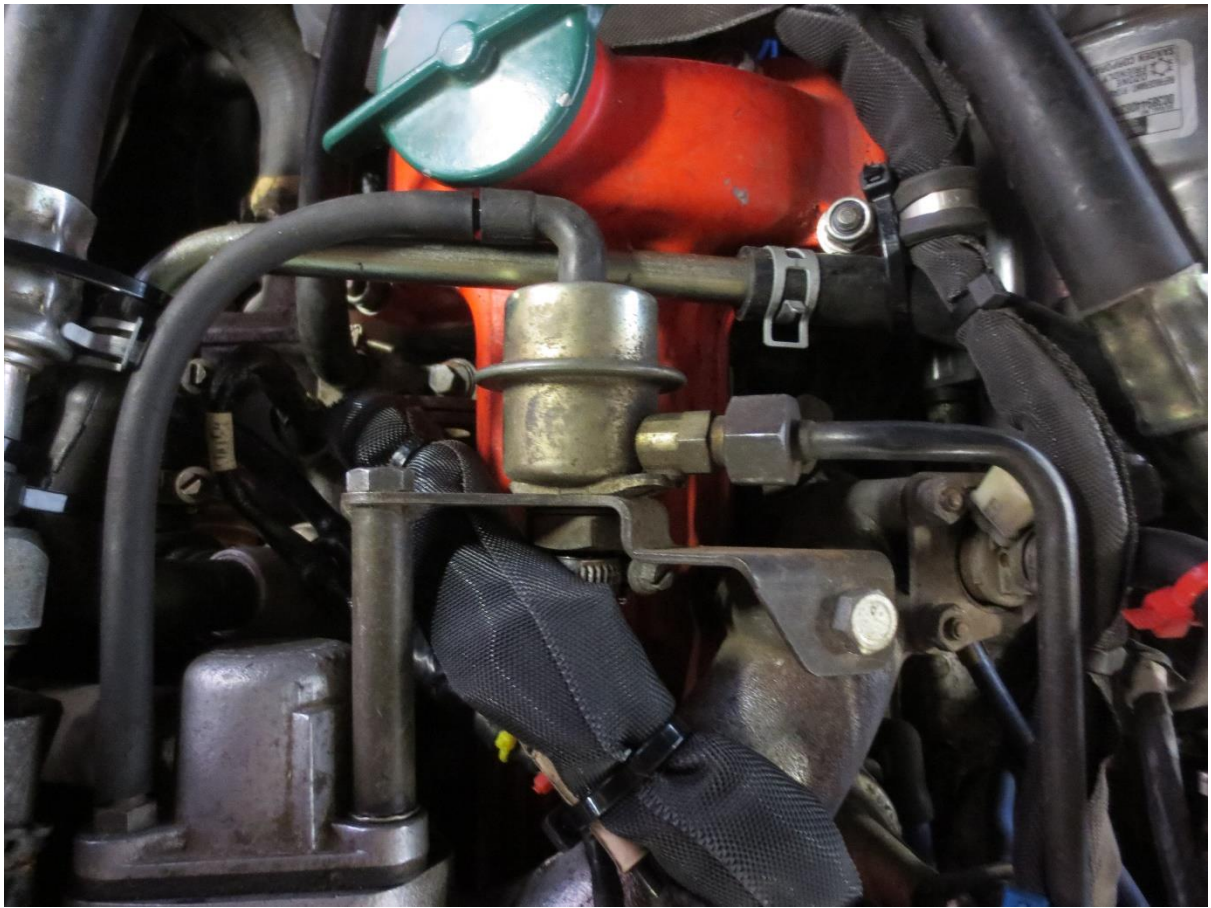

D: Powering and controlling the cold start solenoid

The solenoid is powered by a feed taken from the coil positive terminal, it draws less than an amp and that only when activated, so should not overload the circuit. It has a dedicated inline fuse between the coil terminal and the solenoid. The switching is done to earth from a wire that runs into the cabin through the same routing that the heater unit vacuum tube takes. The cabin switch is installed in the console top just behind the ashtray, together with a dedicated warning light, as shown in the following two photos.

Note that on my car, as the cruise control is removed and I have an electric main fan installed, the cruise control master switch has been repurposed as a switch for the main radiator fan in the event of the thermostatically operated system failing. My car has a "fan running" warning light installed in addition to the cold start warning light and switch.





Conclusions

1. The system works well and maintains the engine at about 800 RPM from stone cold, rising to 1000 RPM after a minute or so:
2. The solenoid can be switched off after a maximum of 5 minutes, even in sub-zero temperatures when the car has not been used for several days
3. The solenoid must be switched on before the car is cranked over on the starter, as otherwise the suction of the engine on the solenoid plunger is obviously greater than the opening force of the solenoid coil!
4. A new solenoid can still be purchased, but it is expensive; however second hand ones are easily available in the UK and quite cheap.
5. The feed pipes from the solenoid to the manifolds need to have an ID of 13mm minimum to provide enough flow and connect to the solenoid easily. I have used thick walled silicone tubing with reinforcing fibres that will easily withstand the engine bay heat and not collapse under manifold vacuum when the cold start system is switched off.
6. I have used this system for the last few months and it works reliably and well, and provides a driver-controlled cold start system, which suits me and my usage pattern better than the original AAV controlled system.
7. A definite and unexpected side benefit of this change is that the tickover of the engine is definitely smoother. My car has always had a very steady tickover, but after this change it became even smoother. My guess is that the vacuum operated PCV valve that was in the system before, shuts and opens somewhat unevenly as the vacuum pulse at tickover fluctuates and it was this that caused any unevenness. That is, it was nothing to do with the AAV change, but to do with the replacement of the PCV to manifold arrangement with the atmospheric catch tank.