

TECHNICAL BULLETIN



Inoperative Blue Relay – Oxidized or Damaged Terminals – Checking/Replacement Guidelines

MODEL 1988-94 MY Sedan Range
XJS Range

DATE 5/97

86-178
Amended
8/97

Remove and destroy Bulletin 86-178 dated 5/97.
Replace with this Bulletin.
Revisions are marked with a bar and in **bold text**.

ISSUE:

The blue Hella relay (part no. DAC 7686) was used in a variety of locations and applications on **XJS and Sedan Range** vehicles.

In many cases relays have been replaced without being diagnosed properly. In other cases, the relay has been replaced with the identical relay in a location where the use of the new sealed relay (part no. LHF 6703AA) is more suitable.

This bulletin outlines what to check before replacing a relay and where to use a sealed relay when replacing a **failed** blue Hella relay.

Malfunction of the relay while installed on the vehicle can be caused by:

- An invisible oxide film on the relay terminals.
- Loose or damaged terminals in the relay base.

NOTE: On 1993-94 (4.0L) Sedan Range and XJS vehicles, the relay controlling the AIR pump clutch should be checked or replaced as outlined in bulletin 17-9 Service Action S 458.

ACTION:

CHECKS TO PERFORM BEFORE REPLACING RELAY

Before replacing a relay, check the following:

- Remove and reinstall the relay for the affected circuit. This action is often enough to clean off the oxide-film and allow the relay to operate correctly. This is particularly the case in circuits where the relay switches a current of only a few milliamps.

- If the relay still does not operate correctly, check the condition of the terminals in the relay's base. Check the force required to insert a terminal blade in each individual terminal of the relay base by using a spare 'Lucar' male terminal (Illustration 1) or by removing the relay and turning it so that one blade can be inserted into each terminal of the relay base, one at a time.

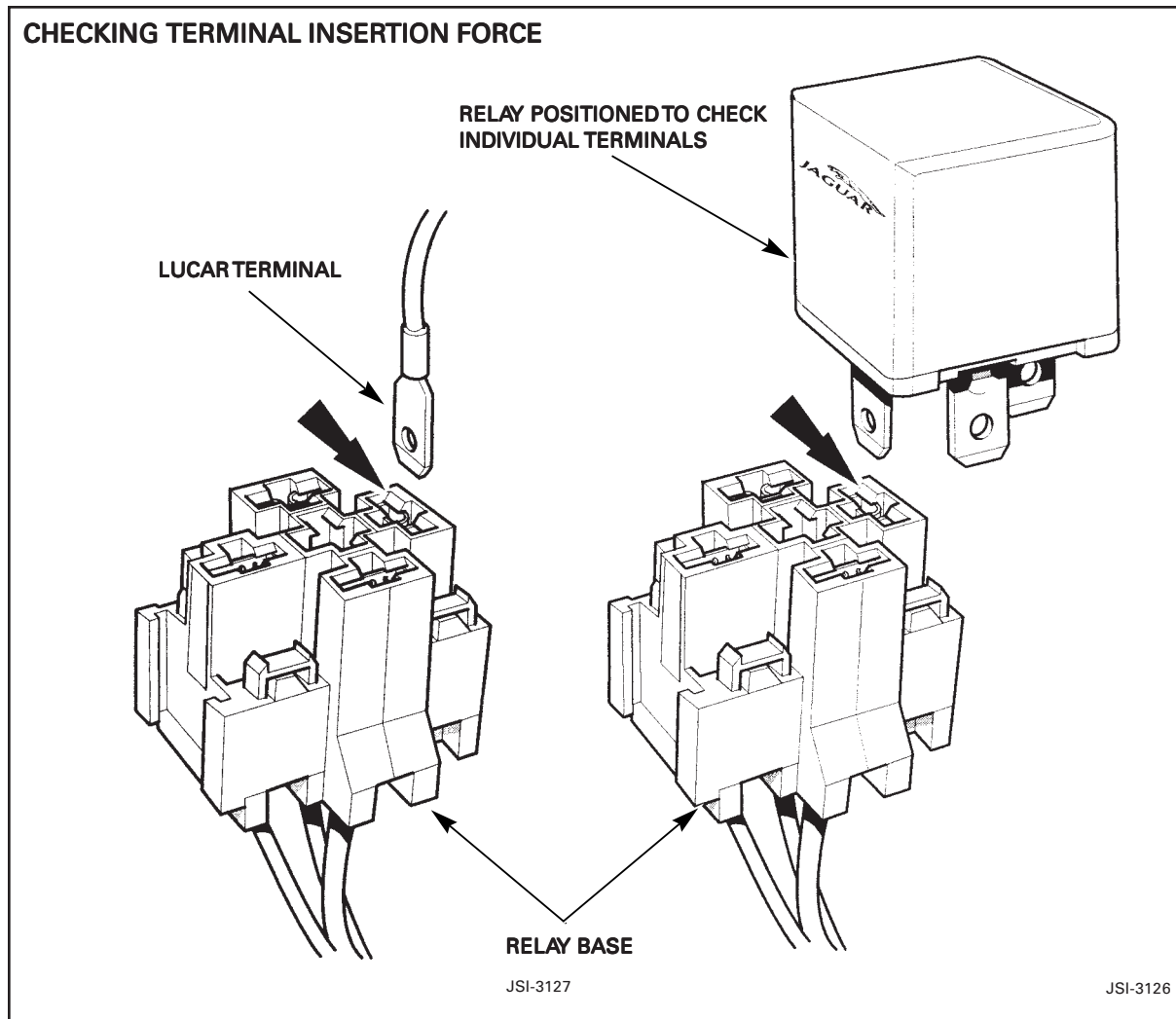

ILLUSTRATION 1

Tighten any loose terminals by pulling the terminal out of the relay base using the previously supplied Jaguar special tools (or equivalent such as Snap-On GA500A) and carefully closing the terminal with pliers to tighten the grip on the relay blade. Do not attempt to tighten the terminal while it is still in the relay base. Insert the terminal back into the relay base. Reinstall the relay and recheck its operation.

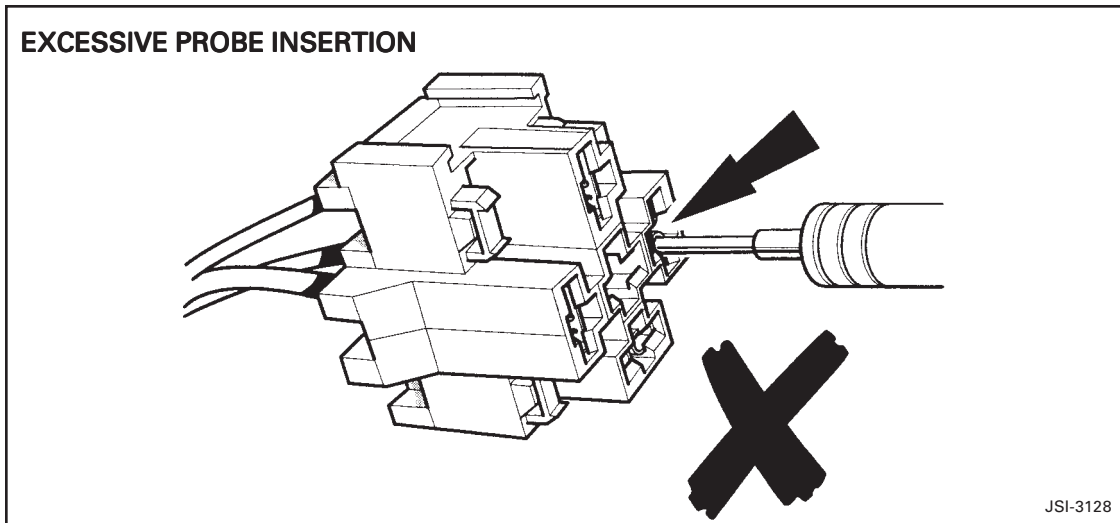

ILLUSTRATION 2

Loose terminals can be caused by forcing multimeter probes deep into the terminals (Illustration 2). To avoid this condition, lightly contact the terminals with the probes (Illustration 3).

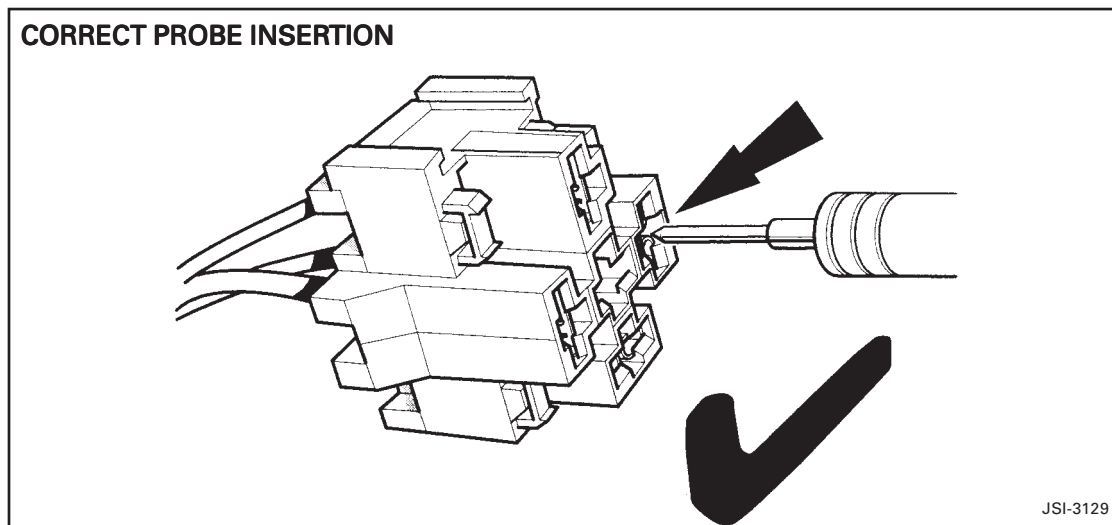

ILLUSTRATION 3

If the relay still does not operate after checking the above, replace the relay after noting the valid applications for the sealed relay as listed on the following page.

APPLICATIONS FOR SEALED RELAYS

A sealed relay (part no. LHF 6703AA) is now available which is interchangeable with part no DAC 7686. When replacing a failed relay in any of the applications listed below (mainly engine compartment) use LHF 6703AA instead of DAC 7686. The sealed relay is more resistant to the entry of water and silicone solutions.

A/C compressor clutch	Air injection pump clutch	ECM controls (XJS)
ECM controls (XJS)	Fuel injection	Fuel pump (Sedan trunk)
Headlights	Horn	Oxygen sensor
Radiator fan (XJS)	Sidelights	Transmission power

For additional information, refer to the vehicle-specific Electrical Guide.
In all other applications, continue to replace the relay with the original type.

NOTE: Do not use any other relay in place of the AGU 1068 and AGU 1070 relays used for high load applications on XJS models.

PARTS INFORMATION:

<u>DESCRIPTION</u>	<u>IDENTIFICATION</u>	<u>PART NUMBER</u>
Relay	Hella DAC 7686 (blue)	DAC 7686
Sealed relay	Hella (black)	LHF 6703AA

WARRANTY INFORMATION:

FAULT

<u>CODE</u>	<u>DESCRIPTION</u>
JZ FB **	A/C compressor clutch relay
BG CC **	Air injection pump clutch relay*
BJ BJ **	Breather heater relay
BX CB **	ECM control relay (XJS)
BC CC **	Fuel injection relay
CZ BC **	Fuel pump relay -AJ6 (sedan trunk)
CZ BB **	Fuel pumps relay -V12 (sedan trunk)
QB MB **	Headlight relay
MD BF **	Horn relay
BB GH **	Oxygen sensor relay
DN GB **	Radiator fan relay (XJS)
MD HB **	Sidelight relay
FZ QB **	Transmission power relay

* see note on page 1.

Refer to the appropriate Warranty Codes & Repair Operation Times Manual for applicable repair operations.