

Jaguar
XJ-S / XJ-SC

Delanair MK III
Air Conditioning
Service Introduction
1987 Model Year



This Page Intentionally Left Blank

INDEX

SYSTEM OPERATION _____	PAGES 2-5
CROSS SECTIONAL DIAGRAM _____	PAGE 6
CIRCUIT DIAGRAM _____	PAGE 7
PRELIMINARY CHECK LIST _____	PAGE 8
FULL ELECTRICAL TEST PROCEDURE _____	PAGES 9-30
NOTES _____	PAGES 31-32

MARK III

AIR CONDITIONING UNIT

ELECTRONIC CONTROL MODULE

The control module is a digital microprocessor. It receives data signals from driver operated switches, then by comparing this data with data received from various temperature sensors and feedback devices, it calculates the output signals needed to operate the blower motors, flap servo motors, compressor and vacuum solenoids to achieve the temperature requirement selected for the vehicle.

Although the control module cannot be repaired in service, a set of test pins are accessible for testing the various circuits by the use of a digital multimeter. GREAT CARE MUST BE EXERCISED WHEN USING THE TEST METER. THE CONTROL MODULE MAY BE IRREPARABLY DAMAGED SHOULD ANY OF THE TEST PINS BE MOMENTARILY SHORTED TOGETHER. This technique should only be used until the new Jaguar Diagnostic System is available, which is designed to test Mark III Air Conditioning fully and comprehensively.

TEMPERATURE DISTRIBUTION SYSTEM

The air conditioning unit case consists of three parts, the rear of which carries the evaporator, the front is then split in two to enable the rotary flaps to be inserted.

The method used to achieve the required air temperature is known as a series parallel system. All the air into the unit passes through the evaporator, then, depending on the position of the flaps either passes through the heater matrix to be heated, or bypasses the heater matrix completely, or a combination of both to achieve the air temperature required. The system employs two flaps that are driven to the required position (determined by the control system) by servo motors and gear box assemblies. The motor can rotate in either a clockwise or anti-clockwise direction depending on the direction of current flow through the motor. The flap positions are monitored by 2K2 ohm feedback potentiometers which supply voltage signals to the control module indicating the flap positions.

TEMPERATURE SELECTOR

The temperature requirement is selected by the setting of a 2K2 ohm potentiometer which is coupled to the temperature control switch. Five (5) volts are supplied to the potentiometer from pin 43 of the control module. The output voltage is from 0 to 2.885 volts, which represents a range of temperatures from 19° to 29°C. The rotation of the potentiometer is restricted internally to 180° travel.

TEMPERATURE SELECTOR SWITCH — AUTOMATIC OVERRIDE FUNCTION

Incorporated within the temperature selector switch is the facility to override the automatic function. This enables the temperature to be manually selected and is achieved by pulling the left hand knob.

Engaging the manual override mode, by pulling out the left hand control knob and dialing the temperature switch within the range available, allows the occupants to select a constant temperature of air entering the passenger compartment. This is permanently maintained regardless of the ambient temperature.

TEMPERATURE DIFFERENTIAL CONTROL

The temperature differential control is used to control the temperature of air being distributed by the face level vents. A 10K ohm slide potentiometer used for this purpose is coupled to the thumbwheel. Its supply voltage is from pin 7, and the signal voltage is then fed to pin 28 of the control module.

TEMPERATURE SENSORS

There are three temperature sensors fitted into the system, the ambient temperature sensor, the in-car temperature sensor and the evaporator temperature sensor.

An input of 5 volts is supplied to the sensors from pin 43 of the control module. The temperature sensing voltage from the sensor is then fed back into the control module. At 0°C (32°F) the sensing voltage should be 2.732 volts, and with a temperature rise or fall of 1°C (1.8°F), the sensing voltage should rise or fall by 0.01 volts; for example, if the temperature should rise to 5°C (41°F) from 0, the voltage will rise by 0.05 volts to 2.782 volts.

COOLANT TEMPERATURE SWITCH

A water temperature switch is fitted to the lower side of the heater inlet pipe. Its contacts are open at temperature below 40°C. This prevents the fans from operating until relatively hot coolant is flowing from the engine.

MODE CONTROL SWITCH

This main control switch provides inputs to the control module giving information regarding the requirements of the operator.

The switch has five positions: OFF, LOW, NORM, HIGH and DEFROST.

In the OFF position, the system is not operational, but a signal from the switch is sent to the control module to ensure the flaps in the fan motor assemblies are closed, preventing outside air from entering the system.

In the LOW, NORM and HIGH positions, information regarding the range of the fan speed is received by the control module from the control switch, temperature selector and the various sensors. Should a low fan speed be selected, the control module will maintain the speed of the fan motor within a range of low speeds depending on the temperature requirement of the vehicle. There are no steps between the fan speeds. The fan speeds are electronically controlled, and by selecting LOW, NORM or HIGH, a level of speed in the range selected is received dependent on the vehicle requirement.

When DEFROST is selected, the fans are electronically controlled to operate at maximum speed, the screen vents open, maximum heating is obtained and the lower level flaps fully close (this operation can take up to a maximum period of 30 seconds).

BLOWER MOTOR SPEED DRIVE CONTROL

Mounted in the outlet of the blower motor units are heatsink assemblies, each of which consist of an interface suppressor diode, a feedback isolation diode and a power transistor.

The unit is supplied with positive battery voltage via an ignition controlled fuse. With the fan motor running at high speed, a relay is energized with a voltage from pin 16 of the control module, thus closing the relay contacts.

On all other fan speeds the ground circuit for the fan motor is via the power transistor and the control module.

The feedback diode enables the control module to sense the voltage at the negative terminal of the fan motor and so calculate the speed of the blower motor.

VACUUM SYSTEM

The components operated by the vacuum solenoids are:

1. Demist flaps which are held closed by vacuum. Identified by a green supply tube.
2. Recirculation/Fresh air flaps which are held closed by vacuum. Identified by a blue supply tube.
3. Center vent, which is opened by vacuum. Identified by a black supply tube.
4. Water valve which is closed by vacuum. Identified by red supply tube.

The vacuum supply to the recirculate/fresh air flaps and the center vent have restrictors so that the operation of these flaps is slowed down to avoid the risk of the system hunting due to the rapid change caused by fast operation time. The recirculation flaps can take up to 30 seconds to change state.

COMPRESSOR CLUTCH CONTROL

The output from pin 20 of the control module is used to energize the compressor clutch relay which will result in the relay contacts closing, allowing battery voltage to the clutch via the thermal fuse.

The control module has protection circuits built in to protect the microprocessor from damage in case of incorrect connections which may be made to the compressor clutch relay.

HIGH SIDE LOW PRESSURE (HSLP) SWITCH

Together with the introduction of the Mark III unit, a new compressor clutch protection system will be progressively introduced.

The HSLP switch is designed to monitor pressure drop on the high side line. At a low pressure condition of 25 psi + 5 psi, the HSLP switch contacts, which are normally closed, open circuit, thus breaking the ground circuit to the compressor clutch coil, resulting in the clutch drive disengaging.

Where a definite fault is present in the air conditioning system, e.g., low refrigerant, restriction, etc., the HSLP switch will remain open circuit until such time as the problem is corrected.

Following rectification and recharging of the system, the HSLP switch will return to a closed state, once again completing the clutch circuit.

The need for the thermal fuse has been deleted with this system and significant benefits are gained especially where a transient fault occurs.

SOME VEHICLES MAY STILL BE EQUIPPED WITH THE SUPERHEAT SWITCH/THERMAL FUSE SYSTEM FOLLOWING MK III LAUNCH. THE OPERATIONAL DETAILS ARE AS FOLLOWS:

SUPERHEAT SWITCH AND THERMAL FUSE

A superheat switch is included in the compressor clutch circuit to provide a compressor protection system. The superheat switch and thermal fuse guards against a low refrigerant charge or blockages causing **extreme** superheated refrigerant vapor conditions resulting in compressor damage. The thermal fuse is a sealed unit containing a heater and a fuse. The superheat switch is located in the rear of the compressor in contact with the suction side refrigerant vapor. With a low refrigerant charge or a blockage, the pressure drops and the temperature rises. This condition closes the superheat switch contacts, which completes the thermal fuse heater circuit, melts the fuse, disconnects the battery supply to the compressor clutch winding and the thermal fuse heater. The compressor ceases to operate and damage from insufficient lubrication will be avoided.

The thermal fuse melts at 157 to 182°C.

Time taken 2 minutes - 14 V battery voltage; 5.5 minutes - 11.5V battery voltage.

The heater resistance, cold 8 to 10 ohms.

CAUTION: After a thermal fuse melt, establish and rectify the cause before replacing the thermal fuse unit complete.

FAULT FINDING

WARNING: THE MICROPROCESSOR IS AN EXTREMELY SENSITIVE AND EXPENSIVE UNIT, AND SHOULD ONLY BE TESTED USING A DIGITAL TYPE MULTI-METER WITH NO LESS THAN A 3.5 DIGIT DISPLAY, AND A RESISTANCE OF NO LESS THAN 2 MEG OHMS. ANY OTHER FORM OF MULTI-METER WILL IRREVERSIBLY DAMAGE THE MICROPROCESSOR. THE TEST PINS ARE MOUNTED VERY CLOSE TOGETHER, THEREFORE, THERE IS A HIGH RISK OF SHORTING TWO PINS TOGETHER WHEN USING A TEST PROBE.

TWO PINS SHORTED TOGETHER, EVEN MOMENTARILY, MAY CAUSE IRREPARABLE DAMAGE TO THE CONTROL MODULE.

To avoid shorting two pins together, 3 insulating sleeves, P/N AMP 87175/3, must be fitted over the test pins.

Always allow 20 seconds for servos to come to rest.

ALWAYS USE THE MICRO-PROCESSOR GROUND POINT LOCATED BEHIND THE RH FOOTWELL OUTLET DURING TEST PROCEDURES. An automatic check will require conditioning all sensors in working area at a known temperature for at least 30 minutes.

NOTE: WHERE "SYSTEM VOLTAGE" IS QUOTED IN THE TEST PROCEDURE, THIS IS EQUIVALENT TO — BATTERY VOLTAGE MINUS 1 VOLT APPROXIMATE.

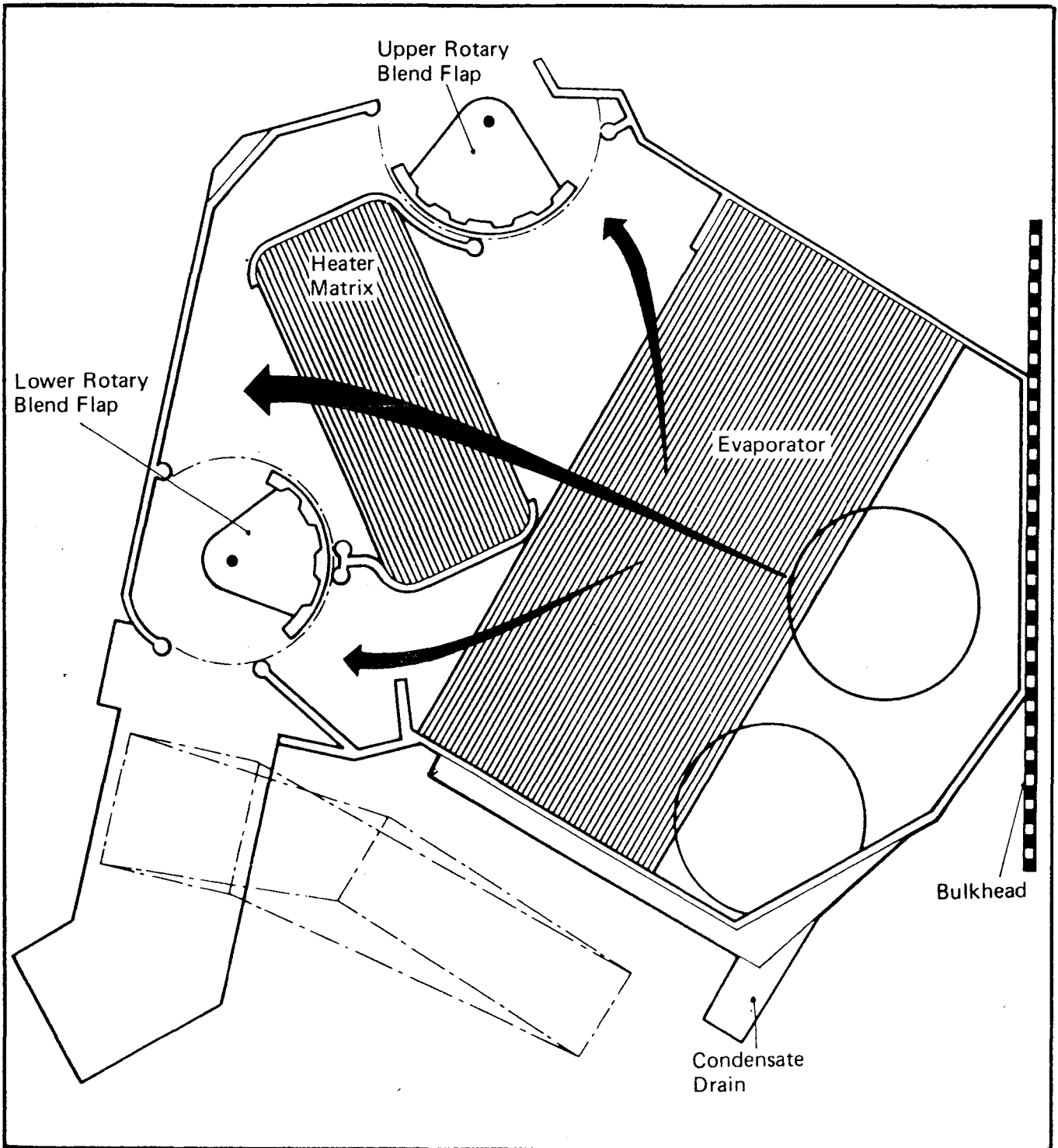

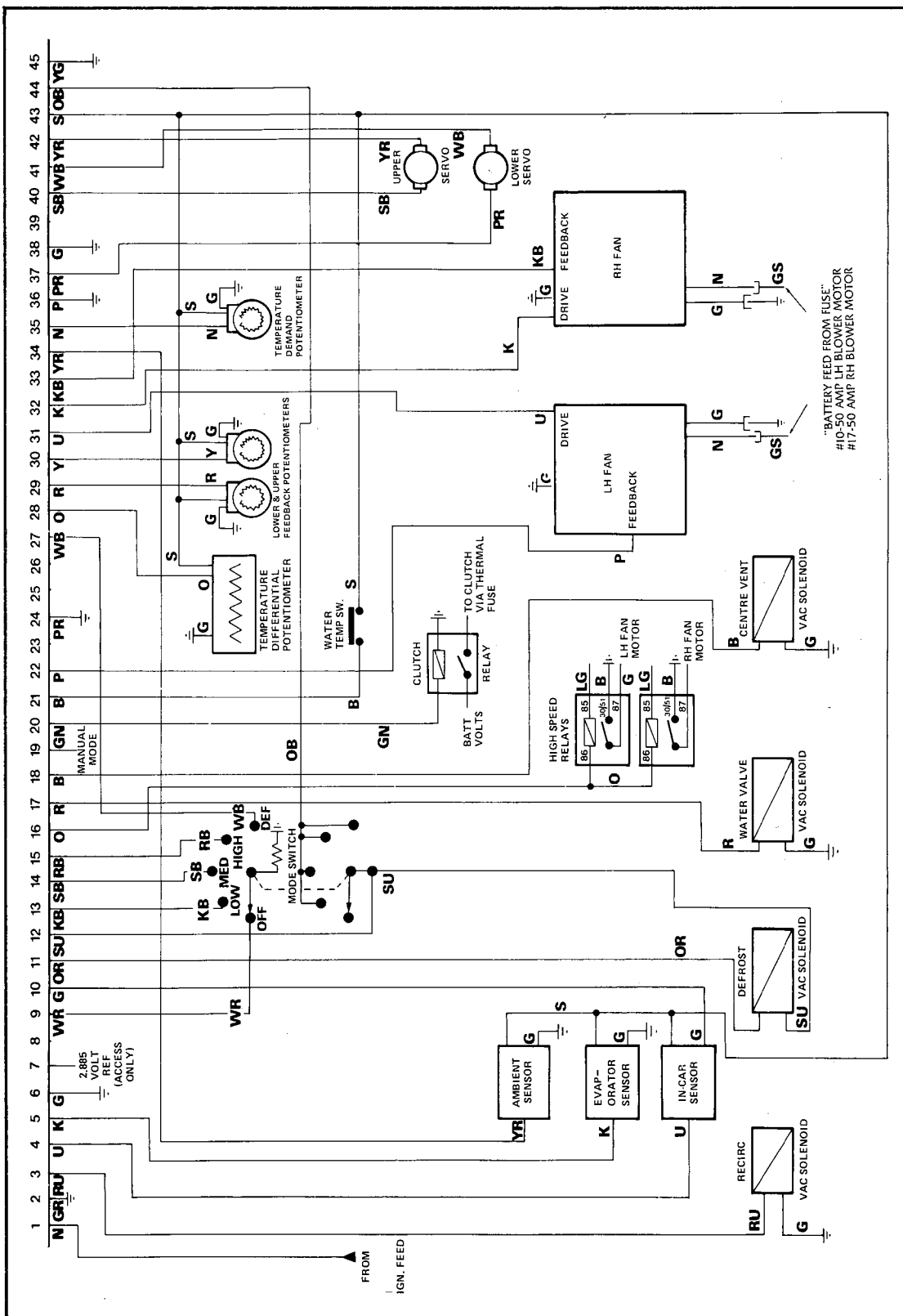

PRELIMINARY CHECK LIST

REFRIGERATION SYSTEM

NOTE: IT IS ESSENTIAL TO FULLY CHECK THE REFRIGERATION SYSTEM PRIOR TO CONDUCTING FULL ELECTRICAL CHECKS.

1. Check for compressor engagement. No Engagement —
 - a) Check fuse adjacent to starter relay at right-hand rear corner of engine bay, 10 amp in-line.
 - b) Check thermal fuse or HSLP switch at compressor, if thermal fuse blown or HSLP switch is open circuit, recharge system and check for leaks or blockages.

VACUUM SYSTEM

2. Check vacuum system for correct operation:
 - a) Ignition on, select manual by pulling out temperature demand control, select 65°F, start engine. After 30 seconds max, water valve should be closed. Recirculation flaps should be open. Center vent should be open.
If no operation, check vacuum supply at air conditioner white supply tube.

ELECTRICAL SYSTEM

3. Check electrical supply fuses.
 - a) Main fuse board at lefthand side below steering column — fuse #11 35A.
 - b) Main fuse board at lefthand side below steering column — fuse #10 50A, Lefthand Blower Motor. Auxiliary fuse board below glove box — Fuse #17 50A Righthand Blower Motor.
 - c) In line fuse at righthand footwell outlet for electronic control module, 3 amp.

TURN IGNITION ON FOR ALL TESTS

Complete Tests In All Stated Positions

TEMP
Switch Position

MODE
Switch Position

85°F
75°F
65°F

OFF
LOW
NORM
HIGH
DEF

Push In For Automatic Control
Pull Out For Manual Control

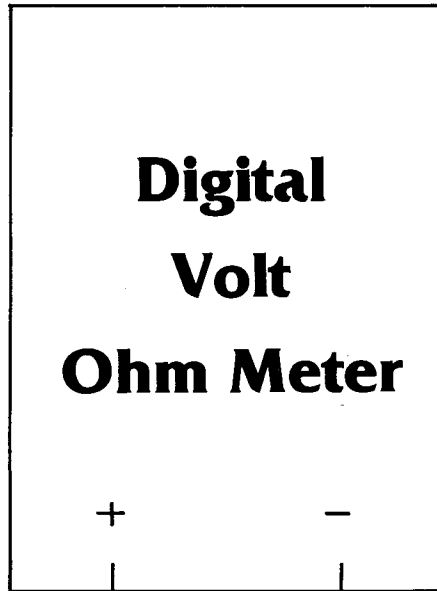

Pin # under test

Pins numbered
top to bottom

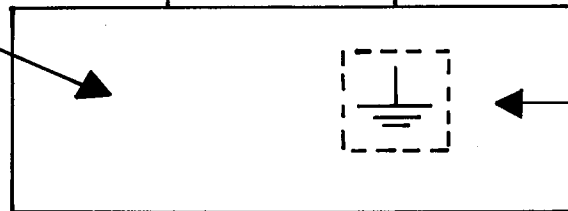

Indicates to use
microprocessor
Lucar connector
as ground

Differential
Control

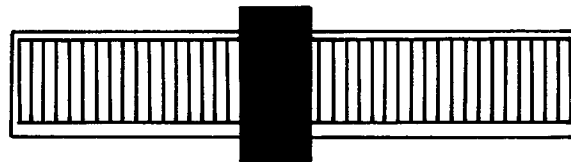

Move control full left or right where indicated

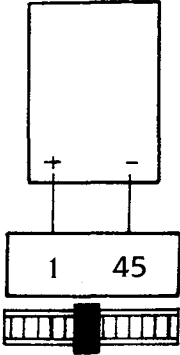
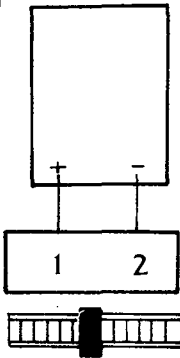
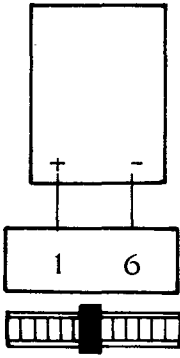
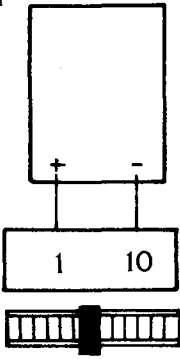
PROCEDURE	RESULT	IF INCORRECT CHECK
<p>TEMP MODE</p> <p>OFF</p>  <p>TEST #1</p>	<p>11 - 14v</p>	<p>Carry out Test #6 — if O.K. check pin #45 for continuity to ground. No continuity, replace electronic control module.</p>
<p>TEMP MODE</p> <p>OFF</p>  <p>TEST #2</p>	<p>11 - 14v</p>	<p>0 Volts — Replace electronic control module.</p>
<p>TEMP MODE</p> <p>OFF</p>  <p>TEST #3</p>	<p>11 - 14v</p>	<p>0 Volts — Replace electronic control module.</p>
<p>TEMP MODE</p> <p>OFF</p>  <p>TEST #4</p>	<p>11 - 14v</p>	<p>0 Volts — Replace electronic control module.</p>

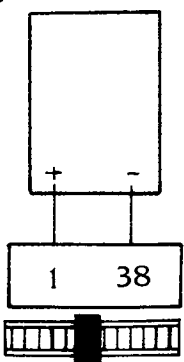
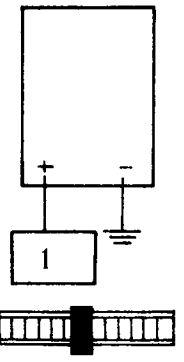
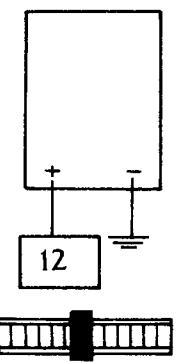
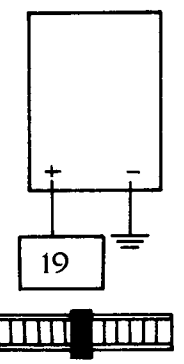
PROCEDURE	RESULT	IF INCORRECT CHECK
<p>TEMP MODE</p>  <p>TEST #5</p>	<p>11 - 14v</p>	<p>0 Volts — Replace electronic control module.</p>
<p>TEMP MODE</p>  <p>TEST #6</p>	<p>11 - 14v</p>	<p>Fuse #11 35 amp — or In line fuse at righthand side of trans tunnel, 3 amp.</p>
<p>TEMP MODE</p>  <p>TEST #7</p>	<p>System Voltage</p>	<p>Replace electronic control module.</p>
<p>TEMP MODE</p> <p>IN LOW NORM HIGH DEF</p>  <p>TEST #8</p>	<p>3.5 - 3.9v</p>	<p>More than 3.9 Volts — replace electronic control module. Less than 3.5 Volts — replace temperature selector switch.</p>

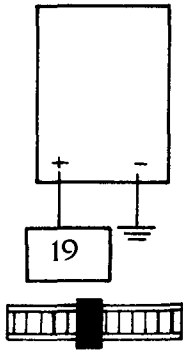
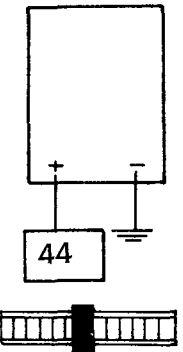
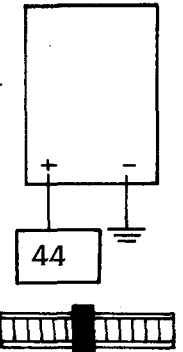
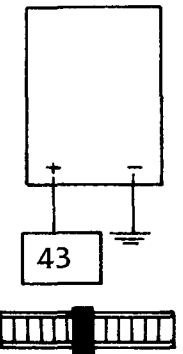
PROCEDURE	RESULT	IF INCORRECT CHECK
<p>TEMP OUT</p>  <p>MODE LOW NORM HIGH DEF</p> <p>TEST #9</p>	<p>0 - 50mv</p>	<p>Replace temperature selector switch.</p>
<p>TEMP OUT</p>  <p>MODE OFF</p> <p>TEST #10</p>	<p>0 - 1v</p>	<p>Replace mode switch.</p>
<p>TEMP OUT</p>  <p>MODE LOW</p> <p>TEST #11</p>	<p>System Voltage</p>	<p>Less than system voltage — check connections.</p>
<p>TEMP OUT</p>  <p>MODE LOW</p> <p>TEST #12</p>	<p>4.75 - 5.25v</p>	<p>Replace control module.</p>

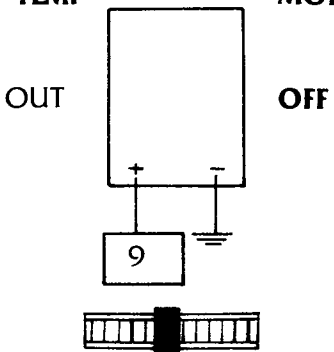
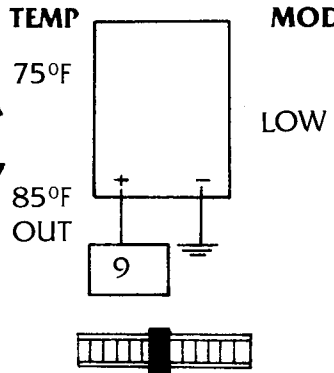
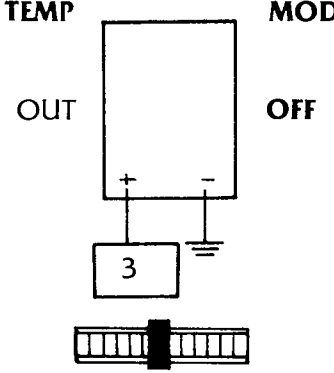
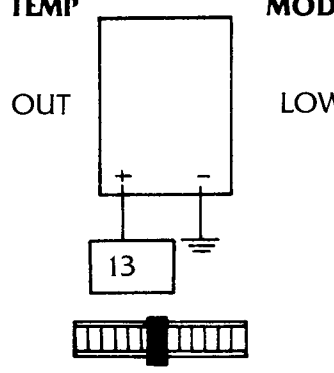
PROCEDURE	RESULT	IF INCORRECT CHECK
<p>TEMP MODE</p> <p>OUT OFF</p>  <p>TEST #13</p>	<p>4 - 5v</p>	<p>If system voltage — replace mode switch.</p>
<p>TEMP MODE</p> <p>75°F LOW</p> <p>Between ↑</p> <p>85°F ↓</p> <p>OUT 9</p>  <p>TEST #14</p>	<p>System Voltage</p>	<p>4 - 5 Volts — replace mode switch.</p>
<p>TEMP MODE</p> <p>OUT OFF</p>  <p>TEST #15</p>	<p>10 - 14v</p>	<p>0 Volts — replace electronic control module.</p>
<p>TEMP MODE</p> <p>OUT LOW</p>  <p>TEST #16</p>	<p>0 - 0.6v</p>	<p>10 - 14 Volts — Replace mode switch.</p>

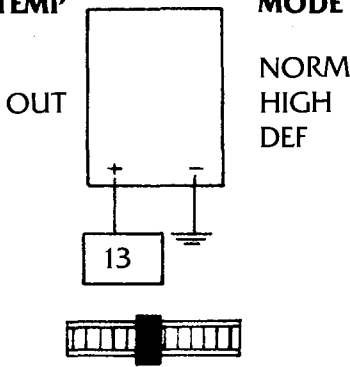
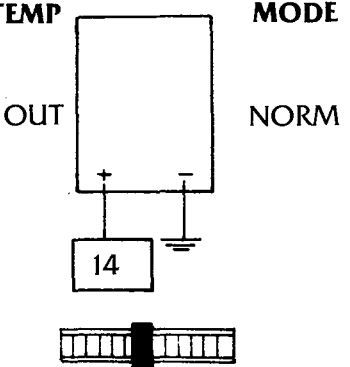
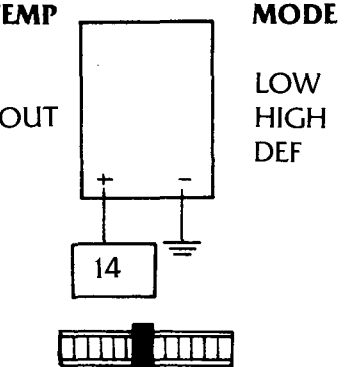
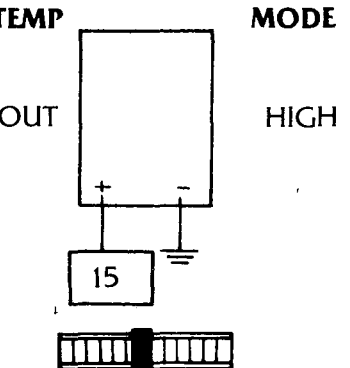
PROCEDURE	RESULT	IF INCORRECT CHECK
<p>TEMP</p> <p>OUT</p>  <p>MODE</p> <p>NORM HIGH DEF</p> <p>TEST #17</p>	<p>2.8 - 4.4v</p>	<p>Replace electronic control module.</p>
<p>TEMP</p> <p>OUT</p>  <p>MODE</p> <p>NORM</p> <p>TEST #18</p>	<p>0 - 0.6v</p>	<p>2.8 - 4.4 Volts — Replace mode switch.</p>
<p>TEMP</p> <p>OUT</p>  <p>MODE</p> <p>LOW HIGH DEF</p> <p>TEST #19</p>	<p>2.8 - 4.4v</p>	<p>Replace electronic control module.</p>
<p>TEMP</p> <p>OUT</p>  <p>MODE</p> <p>HIGH</p> <p>TEST #20</p>	<p>0 - 0.6v</p>	<p>2.8 - 4.4 Volts — Replace mode switch.</p>

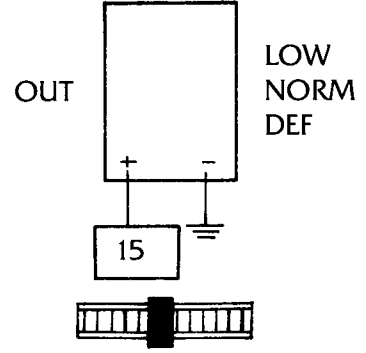
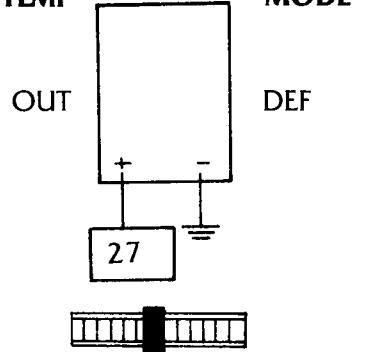
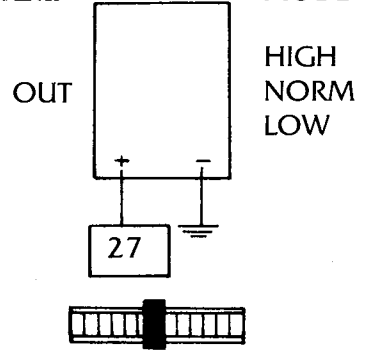
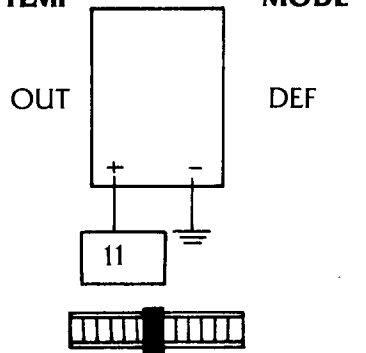
PROCEDURE	RESULT	IF INCORRECT CHECK
<p>TEMP</p> <p>OUT</p>  <p>MODE</p> <p>LOW NORM DEF</p> <p>TEST #21</p>	<p>2.8 - 4.4v</p>	<p>Replace electronic control module.</p>
<p>TEMP</p> <p>OUT</p>  <p>MODE</p> <p>DEF</p> <p>TEST #22</p>	<p>0 - 0.6v</p>	<p>2.8 - 4.4 Volts — Replace mode switch.</p>
<p>TEMP</p> <p>OUT</p>  <p>MODE</p> <p>HIGH NORM LOW</p> <p>TEST #23</p>	<p>2.8 - 4.4v</p>	<p>Replace electronic control module.</p>
<p>TEMP</p> <p>OUT</p>  <p>MODE</p> <p>DEF</p> <p>TEST #24</p>	<p>System Voltage</p>	<p>0 Volts — check connections — replace defrost control solenoid.</p>

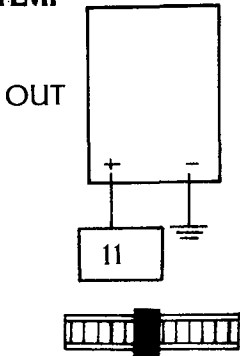
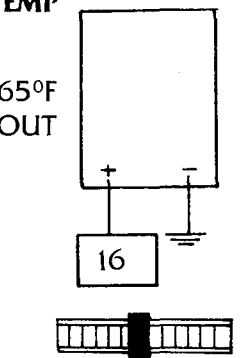
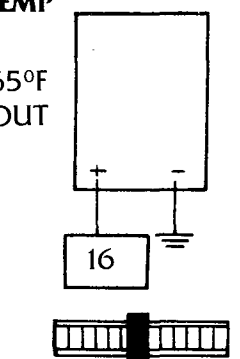
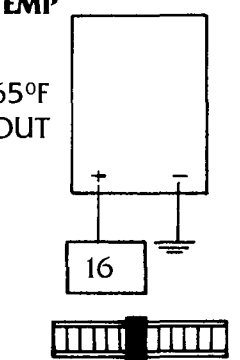
PROCEDURE	RESULT	IF INCORRECT CHECK
<p>TEMP OUT</p>  <p>MODE HIGH NORM LOW</p> <p>TEST #25</p>	<p>0.1 - 0.5v</p>	<p>If system voltage — Replace electronic control module.</p>
<p>TEMP 65°F OUT</p>  <p>MODE LOW</p> <p>TEST #26</p>	<p>0 - 50mv</p>	<p>Electronic control module connections.</p>
<p>TEMP 65°F OUT</p>  <p>MODE NORM</p> <p>TEST #27</p>	<p>0 - 50mv</p>	<p>Electronic control module connections.</p>
<p>TEMP 65°F OUT</p>  <p>MODE HIGH</p> <p>TEST #28</p>	<p>System Voltage Fans at Max Speed</p>	<p>Check connections. Replace electronic control module.</p>

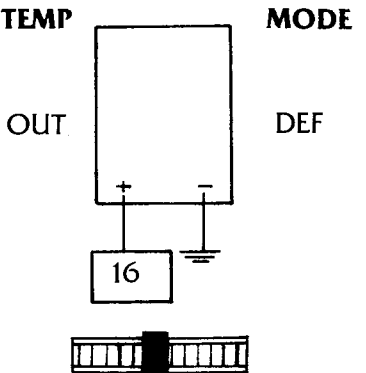
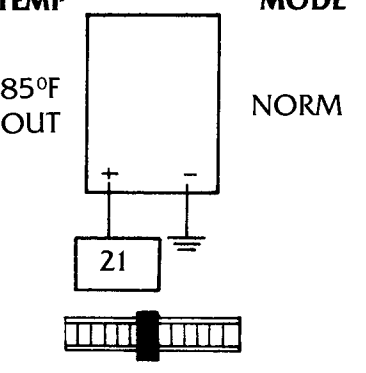
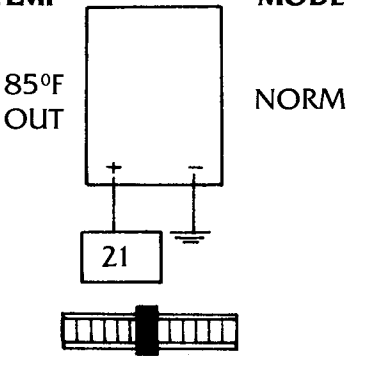
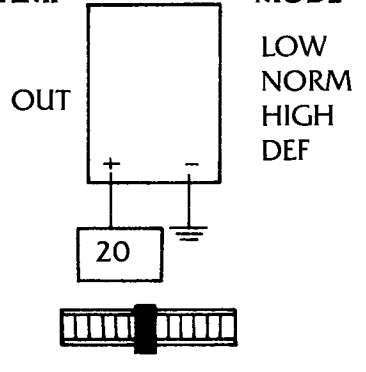
PROCEDURE	RESULT	IF INCORRECT CHECK
<p>TEMP MODE</p> <p>OUT DEF</p>  <p>TEST #29</p>	<p>System Voltage Fans at Max Speed</p>	<p>Replace electronic control module.</p>
<p>TEMP MODE</p> <p>85°F OUT NORM</p>  <p>TEST #30</p>	<p>0 - 0.1v Fans off</p>	<p>Replace water temperature switch.</p>
<p>TEMP MODE</p> <p>85°F OUT NORM</p> <p>Run engine to Normal temp</p>  <p>TEST #31</p>	<p>4.75 - 5.25v Fans on</p>	<p>Replace water temperature switch.</p>
<p>TEMP MODE</p> <p>OUT LOW NORM HIGH DEF</p> <p>Engine running</p>  <p>TEST #32</p>	<p>System Voltage Comp. Clutch engaged</p>	<p>System voltage, but no clutch engagement — check in line fuse and relay righthand side of engine bay. No system voltage — replace electronic control module.</p>

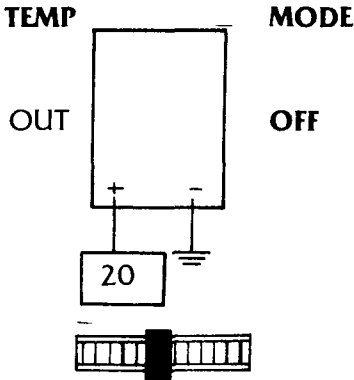
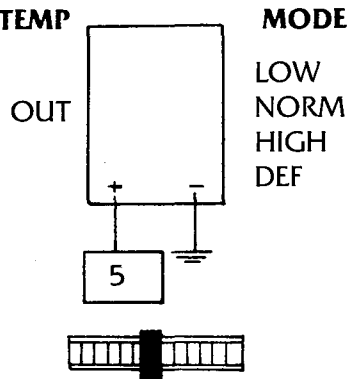
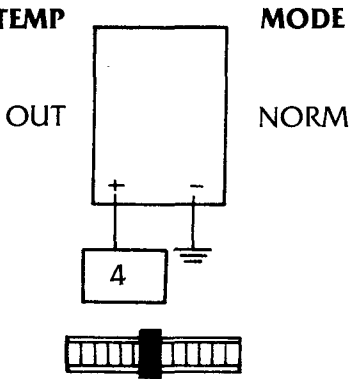
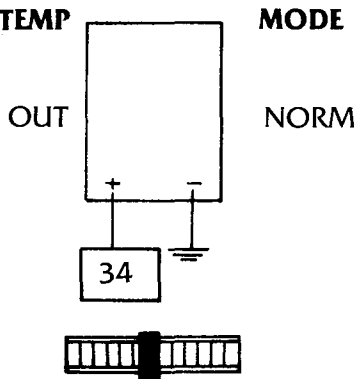
PROCEDURE	RESULT	IF INCORRECT CHECK
<p>Engine running</p> <p>TEST #33</p> 	<p>0 - 1v</p>	<p>Replace electronic control module.</p>
<p>Engine running</p> <p>TEST #34</p> 	<p>Comp. Clutch Disengage at 2.71 - 2.73v Engage at 2.73 - 2.76v</p>	<p>Check connections — replace evaporator sensor.</p>
<p>Engine stopped</p> <p>TEST #35</p> 	<p>2.73 - 2.74v +0.01v for each IN-CAR degree C above 0C</p>	<p>Check connections — replace in car sensor.</p>
<p>TEST #36</p> 	<p>2.73 - 2.74v +0.01V for each AMBIENT degree C above 0C</p>	<p>Check connections — replace ambient sensor.</p>

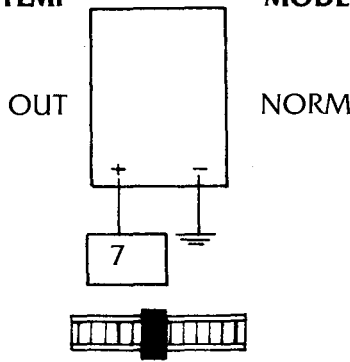
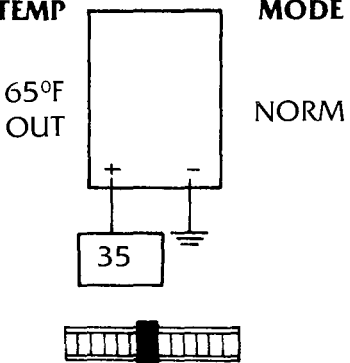
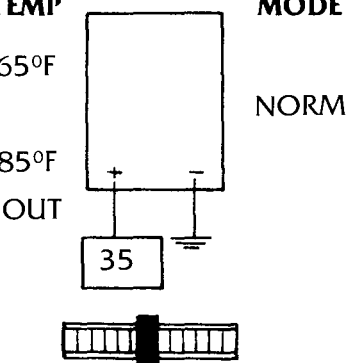
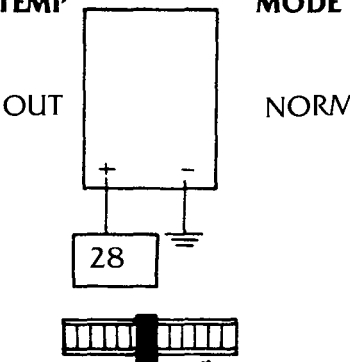
PROCEDURE	RESULT	IF INCORRECT CHECK
<p>TEMP MODE</p> <p>OUT NORM</p>  <p>TEST #37</p>	<p>2.87 - 2.89v ECM Reference voltage</p>	<p>Replace electronic control module.</p>
<p>TEMP MODE</p> <p>65°F OUT NORM</p>  <p>TEST #38</p>	<p>0 - 50mv</p>	<p>Connections to temperature demand potentiometer. If 5 Volts check ground connection at righthand side of air conditioner case.</p>
<p>Move from Slowly to</p> <p>TEMP MODE</p> <p>65°F NORM</p> <p>85°F OUT NORM</p>  <p>TEST #39</p>	<p>Gradual increase 0 - 50mv to 2.87 - 3v at 85°F</p>	<p>Replace temperature demand potentiometer.</p>
<p>TEMP MODE</p> <p>OUT NORM</p>  <p>TEST #40</p>	<p>0-50mv</p>	<p>Ensure differential control was moved to right. If 5 Volts check ground connection.</p>

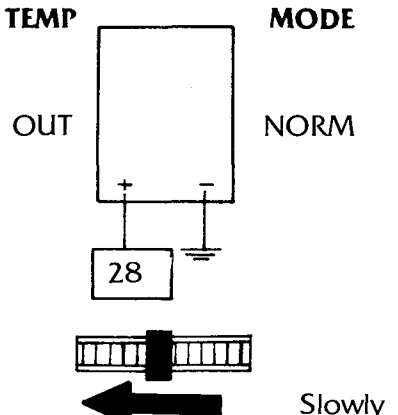
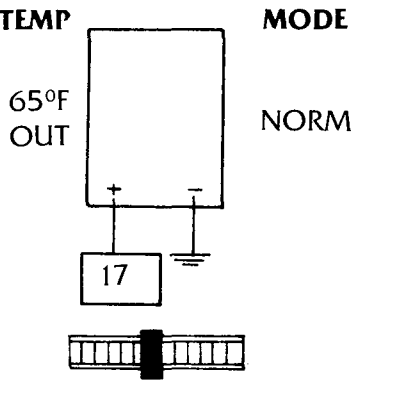
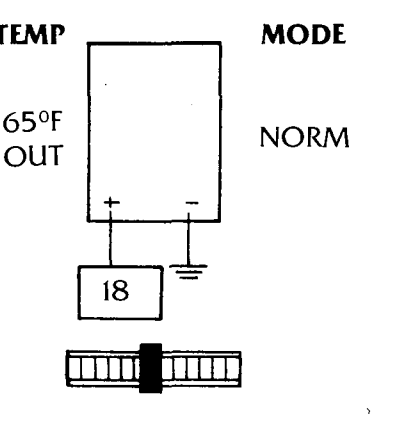
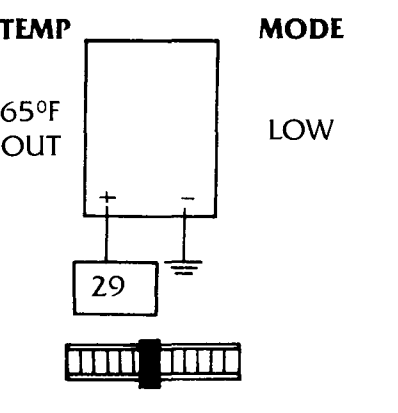
PROCEDURE	RESULT	IF INCORRECT CHECK
<p>TEMP MODE</p> <p>OUT NORM</p>  <p>TEST #41</p>	<p>Increases from 0 - 50mv to 2.67 - 3v</p>	<p>No increase — Replace temperature differential potentiometer.</p>
<p>TEMP MODE</p> <p>65°F OUT NORM</p>  <p>TEST #42</p>	<p>9 -14v</p>	<p>Replace electronic control module.</p>
<p>TEMP MODE</p> <p>65°F OUT NORM</p>  <p>TEST #43</p>	<p>9 -14v</p>	<p>Replace electronic control module.</p>
<p>TEMP MODE</p> <p>65°F OUT LOW</p>  <p>TEST #44</p>	<p>50 -250mv</p>	<p>5 Volt Supply to lower feedback potentiometer — if OK replace lower feedback potentiometer.</p>

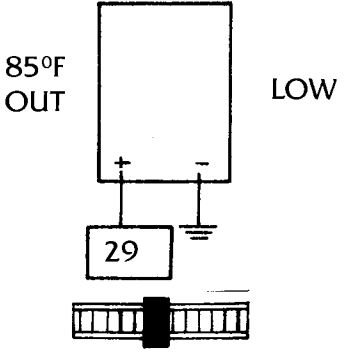
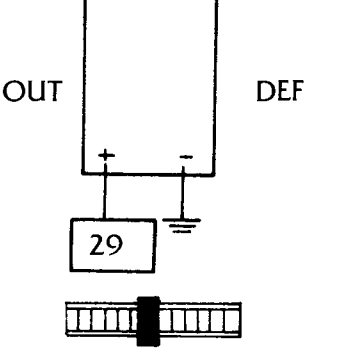
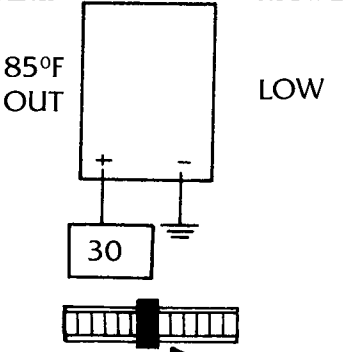
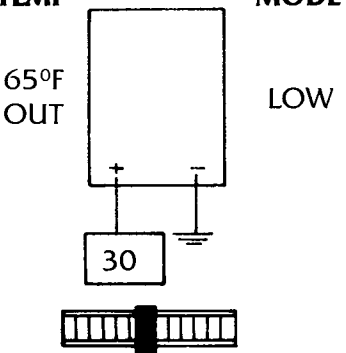
PROCEDURE	RESULT	IF INCORRECT CHECK
<p>TEMP 85°F OUT</p> <p>MODE LOW</p>  <p>TEST #45</p>	<p>1 -1.2v</p>	<p>If no change from test #44 — replace lower feedback potentiometer.</p>
<p>TEMP OUT</p> <p>MODE DEF</p>  <p>TEST #46</p>	<p>2.82 - 2.98v</p>	<p>If no change from test #45 — but test #45 result OK — replace electronic control module.</p>
<p>TEMP 85°F OUT</p> <p>MODE LOW</p>  <p>TEST #47</p>	<p>1.5 - 2v</p>	<p>5 Volt supply to upper feedback potentiometer — if O.K. replace upper feedback potentiometer.</p>
<p>TEMP 65°F OUT</p> <p>MODE LOW</p>  <p>TEST #48</p>	<p>50 - 210mv</p>	<p>If no change from test #47 — replace upper feedback potentiometer.</p>

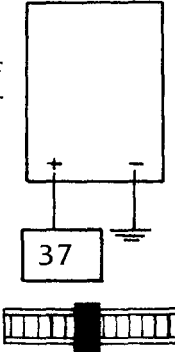
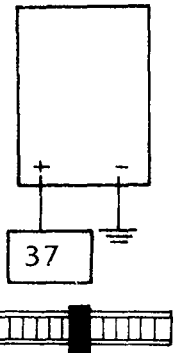
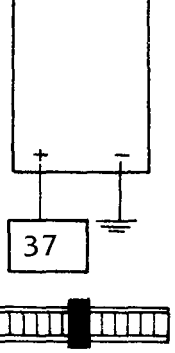
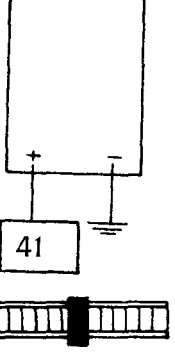
PROCEDURE	RESULT	IF INCORRECT CHECK
<p>TEMP 65°F OUT</p> <p>MODE LOW</p>  <p>TEST #49</p>	<p>0.2 - 1.2v</p>	<p>1.3 to 7.4V replace electronic control module. If 7.5 - 8.5 Volts replace lower feedback potentiometer.</p>
<p>Move from to</p> <p>TEMP 65°F 85°F OUT</p> <p>MODE LOW</p>  <p>TEST #50</p>	<p>0.5 - 2v</p>	<p>Replace electronic control module.</p>
<p>Move from to</p> <p>TEMP 85°F 65°F OUT</p> <p>MODE LOW</p>  <p>TEST #51</p>	<p>6.5 - 7.9v for max 20 sec.</p>	<p>More than 20 seconds replace lower feedback potentiometer. 8.0 to 8.5 Volts — replace lower flap servo motor. 8.6 - 10 Volts — replace electronic control module.</p>
<p>TEMP 65°F OUT</p> <p>MODE LOW</p>  <p>TEST #52</p>	<p>0.2 - 1.2v</p>	<p>1.3 to 7.4V replace electronic control module. If 7.5 - 8.5 Volts — replace lower feedback potentiometer</p>

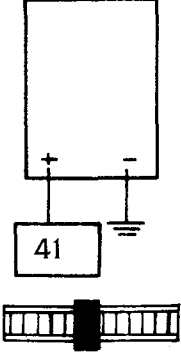
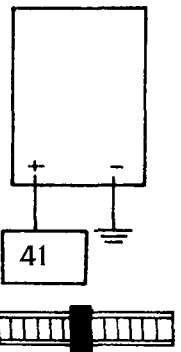
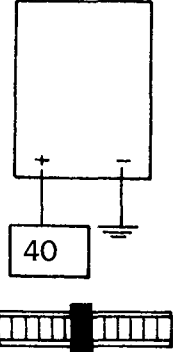
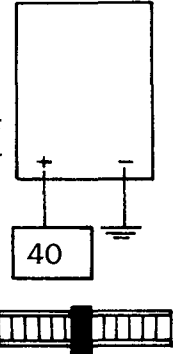
PROCEDURE	RESULT	IF INCORRECT CHECK
<p>TEMP 65°F</p> <p>MODE LOW</p> <p>85°F OUT</p> <p>Move from to</p>  <p>TEST #53</p>	<p>6.5 - 7.9v for max 20 sec.</p>	<p>More than 20 seconds, replace lower feedback potentiometer. 8.0 to 8.5 Volts — replace lower flap servo motor. 8.6 to 10 Volts — replace electronic control module.</p>
<p>TEMP 85°F</p> <p>MODE LOW</p> <p>65°F OUT</p> <p>Move from to</p>  <p>TEST #54</p>	<p>0.5 - 2v</p>	<p>Replace electronic control module.</p>
<p>TEMP 65°F</p> <p>MODE LOW</p> <p>OUT</p>  <p>TEST #55</p>	<p>0.2 - 1.2v</p>	<p>Replace electronic control module.</p>
<p>TEMP 65°F</p> <p>MODE LOW</p> <p>85°F OUT</p> <p>Move from to</p>  <p>TEST #56</p>	<p>0.5 - 2v</p>	<p>Replace electronic control module.</p>

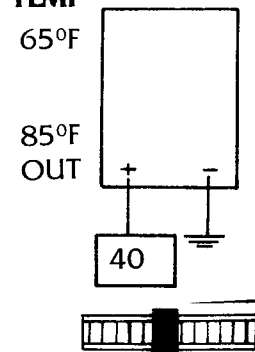
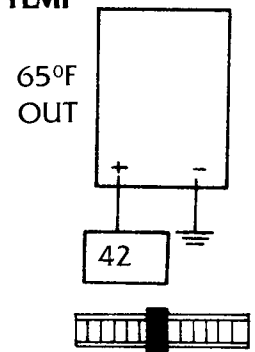
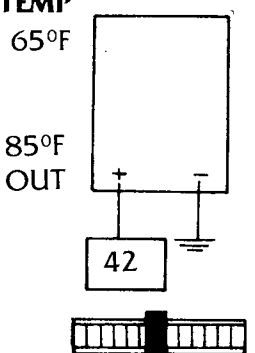
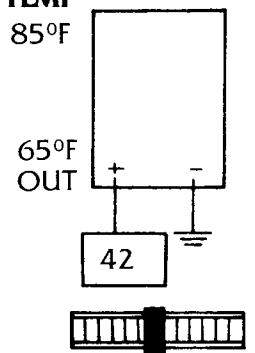
PROCEDURE	RESULT	IF INCORRECT CHECK
<p>Move from to</p> <p>TEMP 65°F 85°F OUT</p> <p>MODE LOW</p>  <p>TEST #57</p>	<p>6.5 - 7.9v for max 20 sec.</p>	<p>More than 20 seconds, replace lower feedback potentiometer. 8.0 to 8.5 Volts — replace upper flap motor. 8.6 to 10 Volts — replace electronic control module.</p>
<p>TEMP 65°F OUT</p> <p>MODE LOW</p>  <p>TEST #58</p>	<p>0.2 - 1.2v</p>	<p>Replace electronic control module.</p>
<p>Move from to</p> <p>TEMP 65°F 85°F OUT</p> <p>MODE LOW</p>  <p>TEST #59</p>	<p>6.5 - 7.9v for max 20 sec.</p>	<p>More than 20 seconds, replace lower feedback potentiometer. 8.0 to 8.5 Volts — replace upper flap motor. 8.6 to 10 Volts — replace electronic control module.</p>
<p>Move from to</p> <p>TEMP 85°F 65°F OUT</p> <p>MODE LOW</p>  <p>TEST #60</p>	<p>0.5 - 2v</p>	<p>Replace electronic control module.</p>

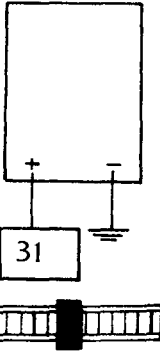
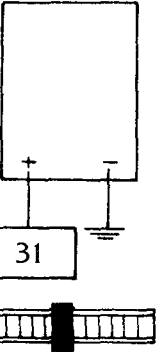
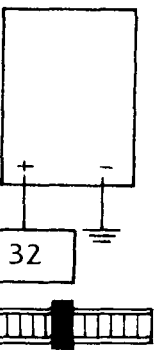
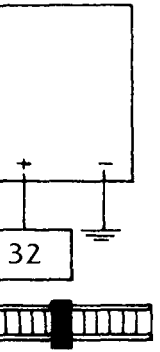
PROCEDURE	RESULT	IF INCORRECT CHECK
<p>TEMP 75°F OUT</p> <p>MODE LOW</p>  <p>TEST #61</p>	1 - 1.5v	Replace fan motor.
<p>TEMP 65°F OUT</p> <p>MODE HIGH</p>  <p>TEST #62</p>	0.75 - 1.75v	Replace fan motor.
<p>TEMP 65°F OUT</p> <p>MODE HIGH</p>  <p>TEST #63</p>	0.75 - 1.25v	Replace fan motor.
<p>TEMP 75°F OUT</p> <p>MODE LOW</p>  <p>TEST #64</p>	1 - 1.5v	Replace fan motor.

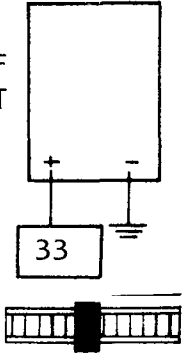
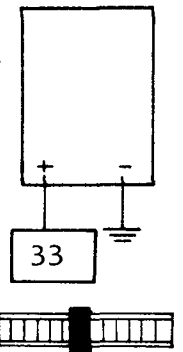
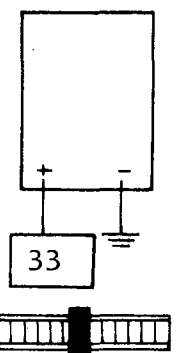
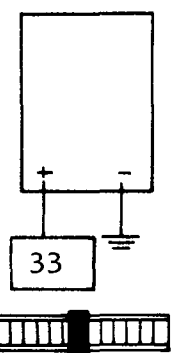
PROCEDURE	RESULT	IF INCORRECT CHECK
<p>TEMP 85°F OUT</p> <p>MODE LOW</p>  <p>TEST #65</p>	<p>4.1 - 5.3v</p>	<p>Below 4.1 Volts — replace Fan motor. Above 5.3 Volts — replace electronic control module.</p>
<p>TEMP 75°F OUT</p> <p>MODE LOW</p>  <p>TEST #66</p>	<p>7.5 - 8v</p>	<p>Below 7.5 Volts — replace Fan motor. Above 8 Volts — replace electronic control module.</p>
<p>TEMP 65°F OUT</p> <p>MODE LOW</p>  <p>TEST #67</p>	<p>3.5 - 4.2v</p>	<p>Below 3.5 Volts — replace Fan motor. Above 4.2 Volts — replace electronic control module.</p>
<p>TEMP 65°F OUT</p> <p>MODE NORM</p>  <p>TEST #68</p>	<p>1.75 - 2.2v</p>	<p>Below 1.75 Volts — replace Fan motor. Above 2.2 Volts — replace electronic control module.</p>

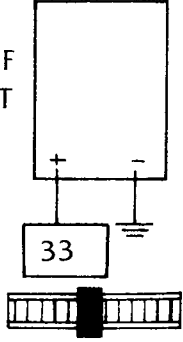
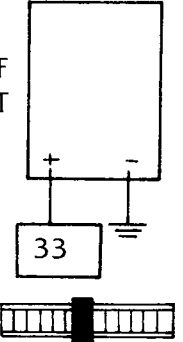
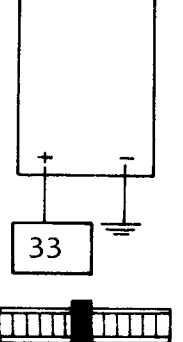
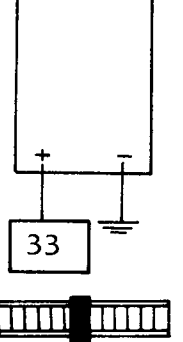
PROCEDURE	RESULT	IF INCORRECT CHECK
<p>TEMP 75°F OUT</p> <p>MODE NORM</p>  <p>TEST #69</p>	<p>5.75 - 6.5v</p>	<p>Below 5.75 Volts — replace Fan motor. Above 6.5 Volts — replace electronic control module.</p>
<p>TEMP 85°F OUT</p> <p>MODE NORM</p>  <p>TEST #70</p>	<p>0.75 - 2.1v</p>	<p>Below 0.75 Volts — replace Fan motor. Above 2.1 Volts — replace electronic control module.</p>
<p>TEMP 85°F OUT</p> <p>MODE HIGH</p>  <p>TEST #71</p>	<p>0.87 - 0.89v</p>	<p>Below 0.87 Volts — replace Fan motor. Above 0.89 Volts — replace electronic control module.</p>
<p>TEMP 75°F OUT</p> <p>MODE HIGH</p>  <p>TEST #72</p>	<p>0.89 - 0.91v</p>	<p>Below 0.89 Volts — replace Fan motor. Above 0.91 Volts — replace electronic control module.</p>

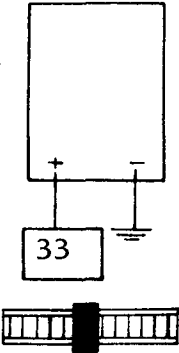
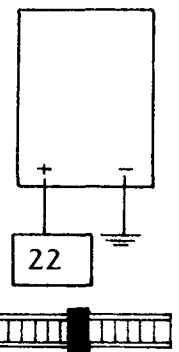
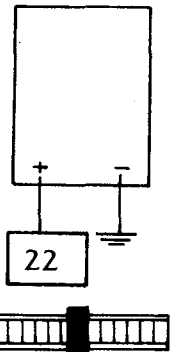
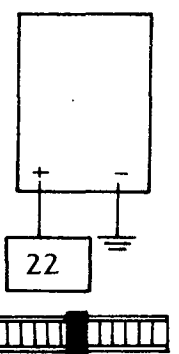
PROCEDURE	RESULT	IF INCORRECT CHECK
<p>TEMP 65°F OUT</p> <p>MODE HIGH</p>  <p>TEST #73</p>	<p>0.9 - 0.91v</p>	<p>Below 0.9 Volts — replace Fan motor. Above 0.91 Volts — replace electronic control module.</p>
<p>TEMP 65°F OUT</p> <p>MODE HIGH</p>  <p>TEST #74</p>	<p>0.85 - 0.91v</p>	<p>Below 0.85 Volts — replace Fan motor. Above 0.91 Volts — replace electronic control module.</p>
<p>TEMP 75°F OUT</p> <p>MODE HIGH</p>  <p>TEST #75</p>	<p>0.85 - 0.91v</p>	<p>Below 0.85 Volts — replace Fan motor. Above 0.91 Volts — replace electronic control module.</p>
<p>TEMP 85°F OUT</p> <p>MODE HIGH</p>  <p>TEST #76</p>	<p>0.87 - 0.89v</p>	<p>Below 0.87 Volts — replace Fan motor. Above 0.89 Volts — replace electronic control module.</p>

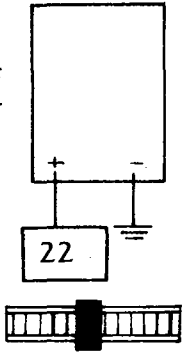
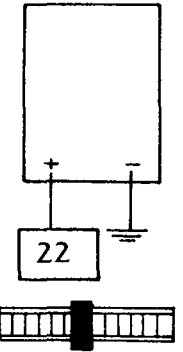
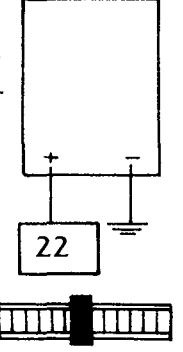
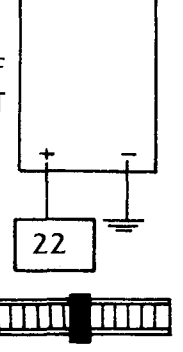
PROCEDURE	RESULT	IF INCORRECT CHECK
<p>TEMP 85°F OUT</p> <p>MODE OFF</p>  <p>TEST #77</p>	<p>0.75 - 2.1v</p>	<p>Below 0.75 Volts — replace Fan motor. Above 2.1 Volts — replace electronic control module.</p>
<p>TEMP 75°F OUT</p> <p>MODE OFF</p>  <p>TEST #78</p>	<p>5.75 - 6.5v</p>	<p>Below 5.75 Volts — replace Fan motor. Above 6.5 Volts — replace electronic control module.</p>
<p>TEMP 65°F OUT</p> <p>MODE NORM</p>  <p>TEST #79</p>	<p>1.75 - 2v</p>	<p>Below 1.75 Volts — replace Fan motor. Above 2.0 Volts — replace electronic control module.</p>
<p>TEMP 85°F OUT</p> <p>MODE LOW</p>  <p>TEST #80</p>	<p>3.5 - 4v</p>	<p>Below 3.5 Volts — replace Fan motor. Above 4.0 Volts — replace electronic control module.</p>

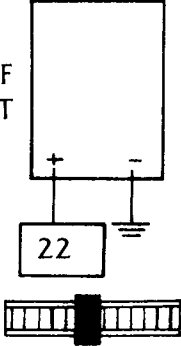
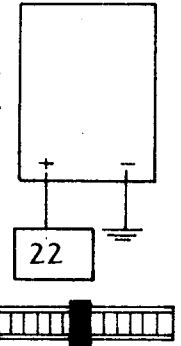
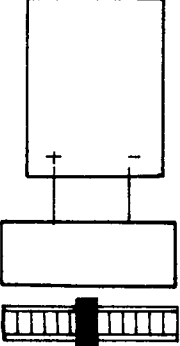
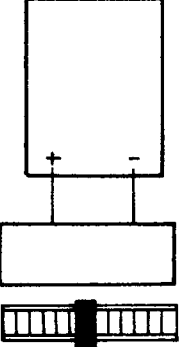
PROCEDURE	RESULT	IF INCORRECT CHECK
<p>TEMP MODE</p> <p>85°F OUT</p>  <p>TEST #81</p>	<p>7.5 - 8v</p>	<p>Below 7.5 Volts — replace Fan motor. Above 8 Volts — replace electronic control module.</p>
<p>TEMP MODE</p> <p>85°F OUT</p>  <p>TEST #82</p>	<p>4.1 - 4.9v</p>	<p>Below 4.1 Volts — replace Fan motor. Above 4.9 Volts — replace electronic control module.</p>
<p>TEMP MODE</p> <p>OFF</p>  <p>TEST #3</p>	<p>11 - 14v</p>	
<p>TEMP MODE</p> <p>OFF</p>  <p>TEST #4</p>	<p>11 - 14v</p>	

Notes

Notes